

L	40.0	45.5	51.0
B	29.0	34.5	40.0
A	10.3	13.1	15.8
C	9.8	15.3	20.8
E	20.8	26.3	31.8

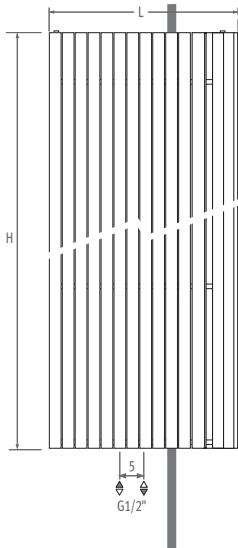

Onderdelen - Parts - Teile

2x

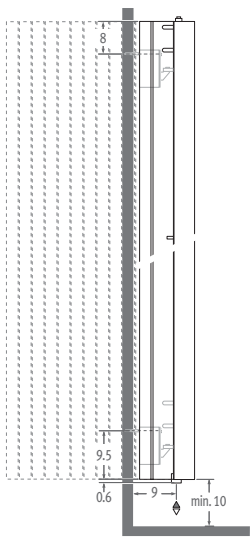
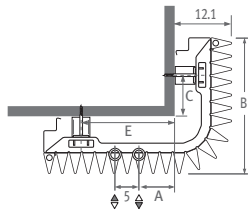
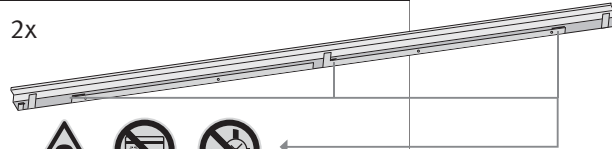

Magneten voor bevestiging zijn voorgemonteerd  
Aimants de montage sont prémontés  
Die Magneten zur Befestigung sind vormontiert  
Magnets for assembly are pre-mounted

4x

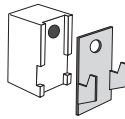

Om veiligheidsredenen zijn geen muurpluggen meegeleverd.  
Contacteer uw specialzaak voor het juiste type.

Pour des raisons de sécurité, les chevilles ne sont pas fournies.  
Contactez votre magasin spécialisé pour le bon type de cheville.

Aus Sicherheitsgründen sind kein Dübel mitgeliefert.  
Kontaktieren Sie Ihren Baustoffhandel für die richtigen Dübel.

For safety reasons wall plugs aren't delivered.  
Contact your specialist store for the right type.

Optie - option



Code 5090.1111

Code 5090.1110

Code 5090.1119

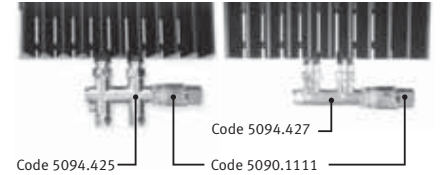

Code 5094.425

Code 5090.1111

Standaard  
Standard



Klemkoppelingen voor ventielen: zie Jaga prijslijst.

Raccords bicônes pour vannes: voir liste des prix Jaga.

Klemmringverschraubungen für Ventile: siehe Jaga Preisliste.

Sleeve couplings for valves: see Jaga price list.

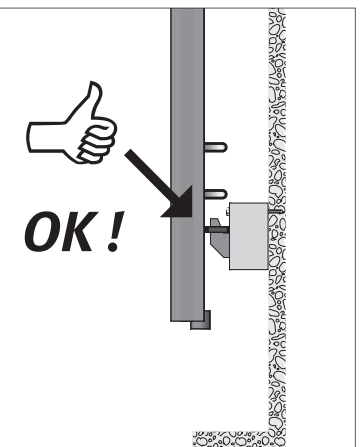
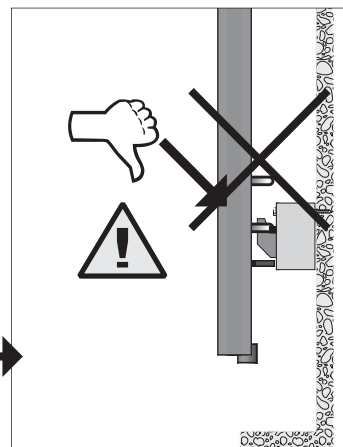
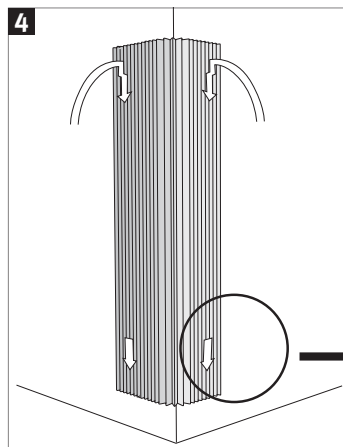
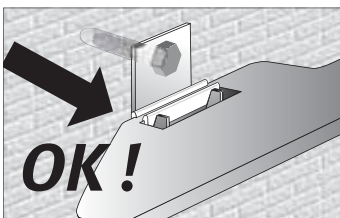
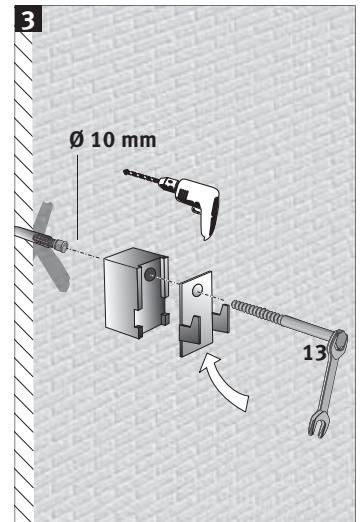
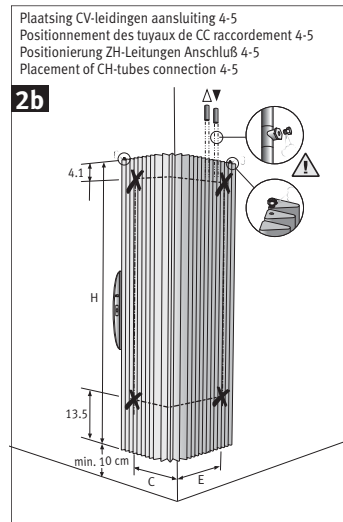
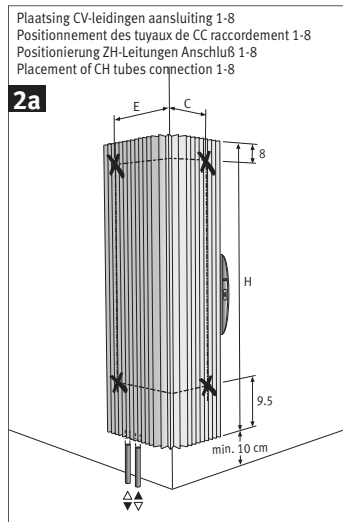
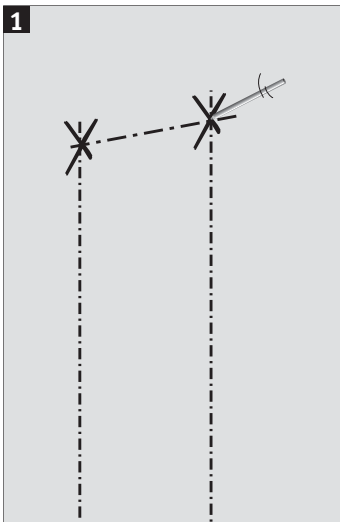

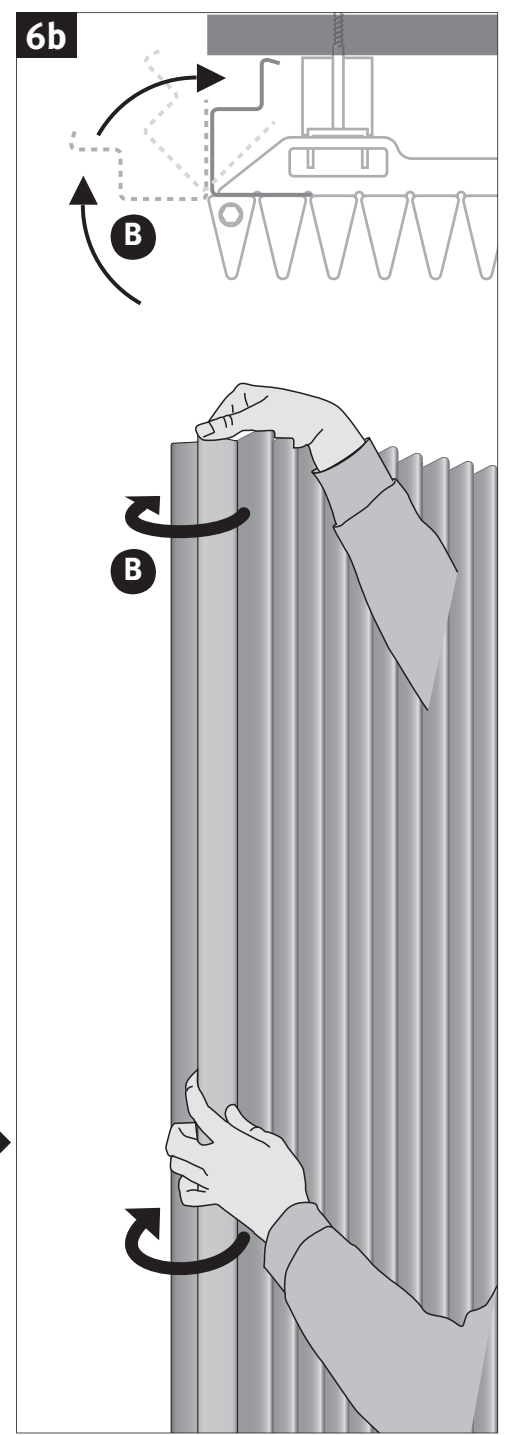
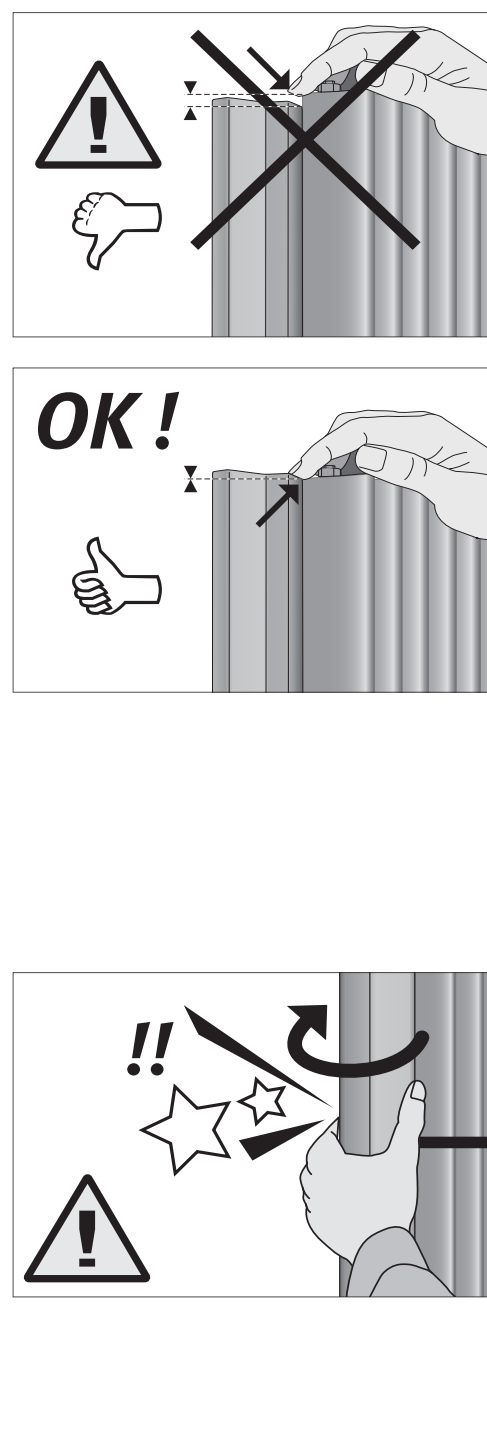
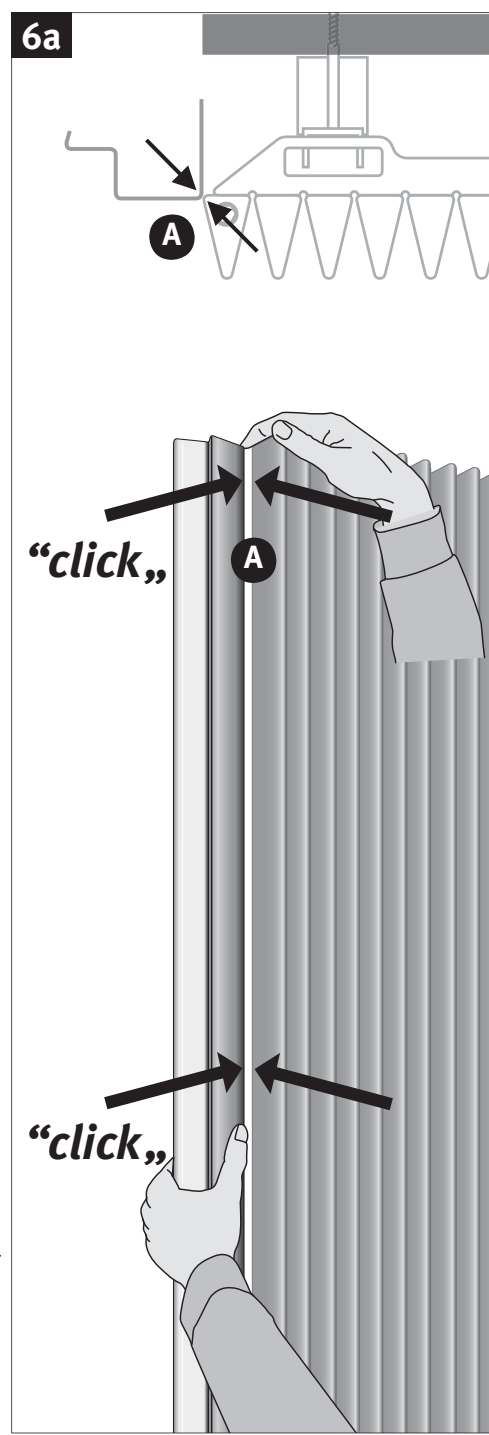
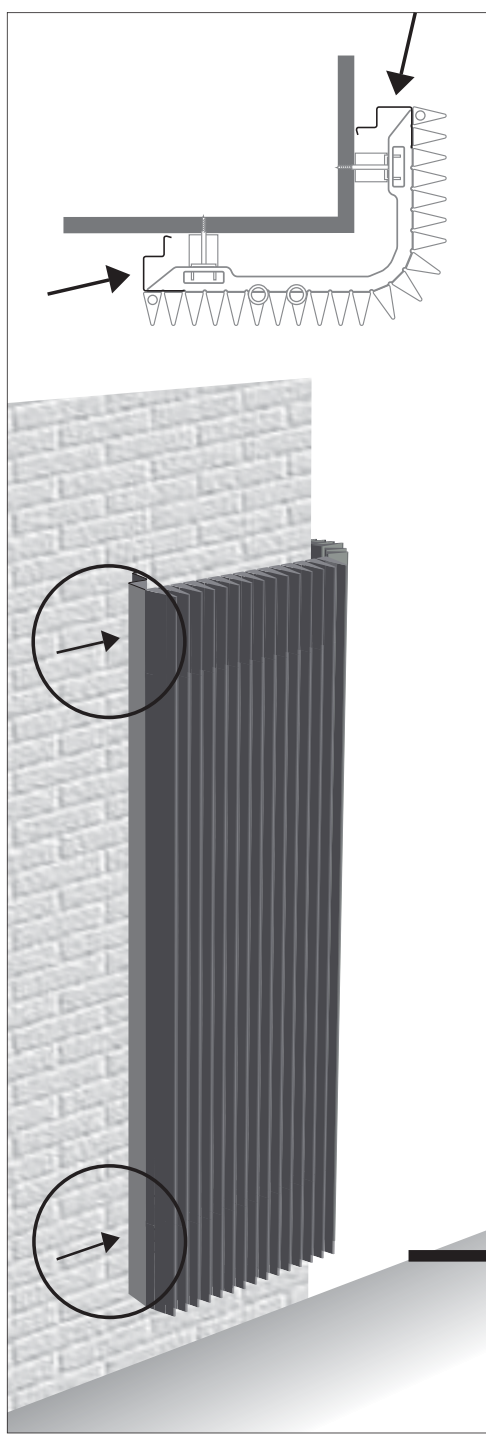

### Aansluiting / Raccordement / Anschluß / Connection

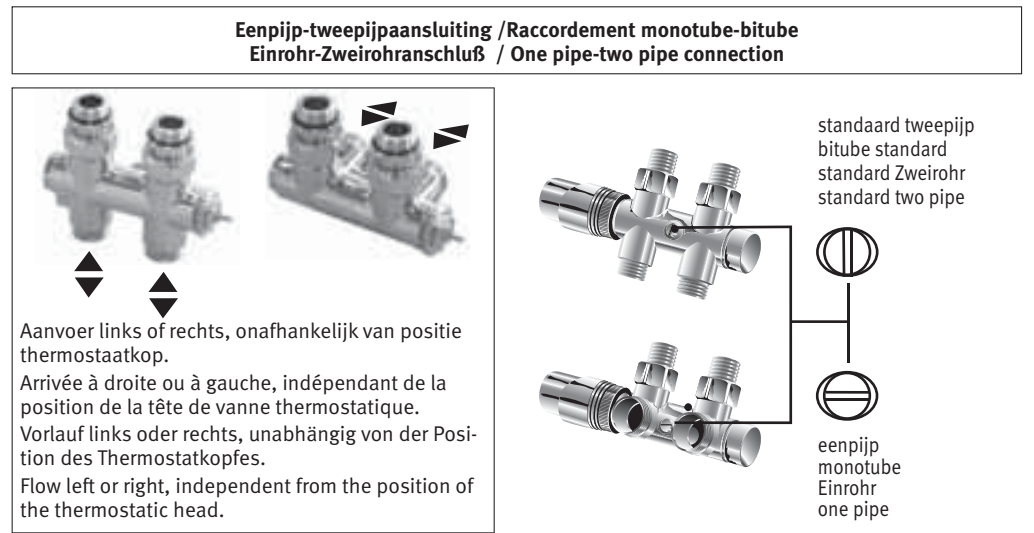
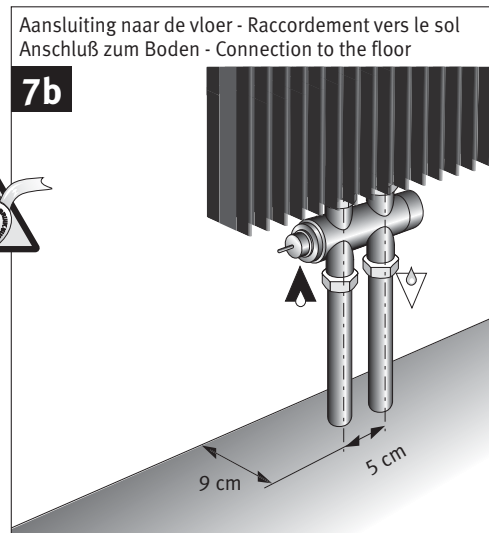
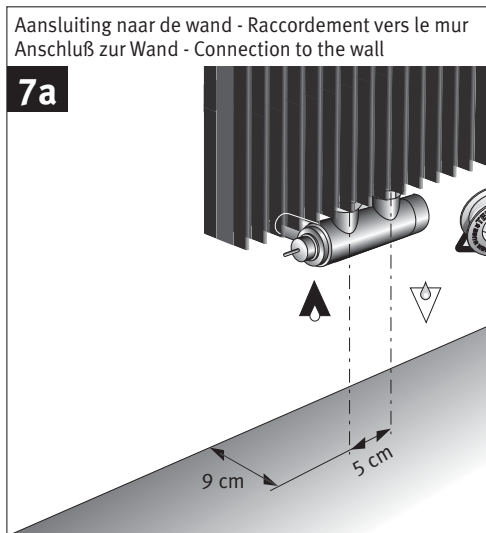

#### OPMERKING

Om de afgifte van de Iguana modellen te garanderen en de drukverliezen te beperken, adviseert Jaga het gebruik van Deco-Pro ventielen, samen met buisdiameter 16/2, 18/1 of 18/2.

#### REMARQUE

Afin de garantir les émissions calorifiques des modèles Iguana et de réduire les pertes de charge, Jaga conseille l'emploi des vannes Deco-Pro, en combinaison des diamètres de tuyau 16/2, 18/1 ou 18/2.

#### BEMERKUNG

Um die Wärmeleistung des Modells "Iguana" zu gewährleisten, empfiehlt Jaga den Einbau von Jaga Deco-Pro Ventilen und den Gebrauch von Rohrdurchmesser 16/2, 18/1 oder 18/2 unter Berücksichtigung der Druckverluste.

#### NOTICE

To guarantee the output of the Iguana models and to limit the pressure drop, Jaga recommends the use of tube diameter 16/2, 18/1 or 18/2.