

12. WALL MOUNTED TYPE PACKAGED AIR-CONDITIONER (Split system, Air to air) heat pump type

Refrigerant R22 use models

FDKN208HEN-S1

258HEN-S1

Alternative refrigerant R407C use models

FDKNP208HEN-S

258HEN-S

308HEN-S

308HES-S

CONTENTS

12.1 GENERAL INFORMATION	471
12.1.1 Specific features	471
12.1.2 How to read the model name	471
12.2 SELECTION DATA	472
12.2.1 Specifications	472
12.2.2 Range of usage & limitations	478
12.2.3 Exterior dimensions	479
12.2.4 Exterior appearance	485
12.2.5 Piping system	486
12.2.6 Selection chart	488
12.2.7 Noise level	490
12.3 ELECTRICAL DATA	491
12.3.1 Electrical wiring	491
12.4 OUTLINE OF OPERATION CONTROL BY MICROCOMPUTER	497
12.5 APPLICATION DATA	497
12.5.1 Installation of indoor unit	498
12.5.2 Installation of outdoor unit	501
12.6 MAINTENANCE DATA	501

12.1 GENERAL INFORMATION

12.1.1 Specific features

- (1) Less refrigerant charge amount due to use of double phase refrigerant flow system. The total refrigerant charge amount has been reduced by more than 50%.
- (2) The indoor outdoor interconnection signal wiring has been done away with. The microcomputer chip is installed in the indoor unit. There is no need for the unit to communicate between the outdoor and indoor units so the unit is more resistant to electromagnetic noise thus the incidence of microcomputer malfunction has been reduced. The compressor in the outdoor unit has its own self protection function, that reacts according to abnormal high pressure and excessive high temperature.
- (3) There are only five power line between the outdoor and indoor unit. As no signal wire is used there is no need to separate the power line from the signal line. One cab tyre cable with 6 wires encased in one sheath is enough for conducting the wiring work between the outdoor unit and the indoor unit. This contributes to simpler wiring work in the field.
- (4) All air supply ports have auto swing louvers. The indoor fan motor has two speeds of high and low.
- (5) All models have service valves protruding from the outdoor unit for faster flare connection work in the field.

(6) Aero trap louver

- (a) Pleasantness will be enhanced with the employment of aero trap louver. It has an excellent wind orientation and a homogeneous air conditioning feeling is ensured at every corner in a room with the auto swing blasting which can be adjusted the maximum 70° downward.
- (b) Louver angle can be adjusted to 4 fixed positions with the remote control. It can be adjusted at any optional angle during the manual operation. Sidewise blast is adjustable by 40° in each direction.

(7) Low noise

- (a) Specially developed silent fan is employed. A very gentle operation sound is assured because the noise like wind slashing sound are suppressed effectively.

(8) Thin and compact design

- (a) The unit measures 17.9 cm (208 type) or 19.6 cm (258, 308 type) in thickness and its size is so compact as a room air conditioner. Body of the unit is dinished in the ivory white color and a pleasant and simple design produces a very pleasant harmony for the interior design.

12.1.2 How to read the model name

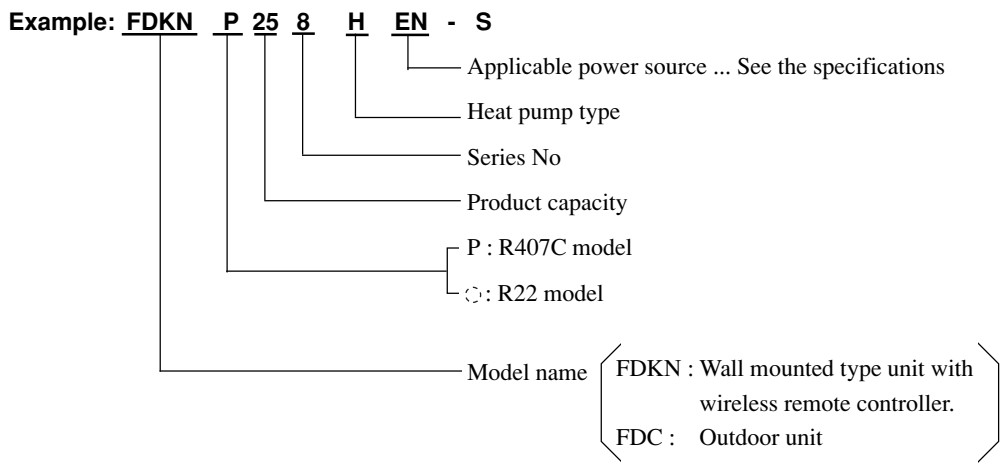

12.2 SELECTION DATA

12.2.1 Specifications

(1) Refrigerant R22 use models
Model FDKN208HEN-S1

Item		Model	FDKN208HEN-S1	
			FDKN208H	FDC208HEN3A
Nominal cooling capacity⁽¹⁾		W	4850	
Nominal heating capacity⁽¹⁾		W	5400	
Power source			1 Phase, 220/240V, 50Hz	
Operation data⁽³⁾	Cooling input	kW	1.76/1.85	
	Running current (Cooling)	A	8.2/8.0	
	Power factor (Cooling)	%	98/96	
	Heating input	kW	1.72/1.82	
	Running current (Heating)	A	8.0/7.8	
	Power factor (Heating)	%	98/97	
	Inrush current (L.R.A)	A	44	
	Noise level ⁽⁴⁾	dB(A)	Hi: 45 Lo: 38	52
Exterior dimensions				
Height × Width × Depth		mm	275 × 790 × 179	690 × 880 × 290
Net weight		kg	10	49
Refrigerant equipment				
Compressor type & Q'ty			–	RM5523GNE4 × 1
Motor		kW	–	1.7
Starting method			–	Line starting
Heat exchanger			Louver fins & inner grooved tubing	Slitted fins & bare tubing
Refrigerant control			Capillary tube	
Refrigerant			R22	
Quantity		kg	Holding charged	0.98 [Pre-charged up to the piping length of 5m]
Refrigerant oil		ℓ	–	0.7 (BARREL FREEZE 32SAM)
Defrost control			MC controlled de-icer	
High pressure control			High pressure switch	
Air handling equipment				
Fan type & Q'ty			Tangential fan × 1	Propeller fan × 1
Motor		W	26 × 1	55 × 1
Starting method			Line starting	Line starting
Air flow (Standard)		CMM	Hi:16 Lo:10	56
Fresh air intake			Unavailable	–
Air filter, Q'ty			Long life filter ×2(washable)	–
Shock & vibration absorber			Rubber sleeve (for fan motor)	Rubber mount (for compressor)
Electric heater		W	–	20 (Crank case heater)
Operation control				
Operation switch			Wireless remote control switch	– (Indoor unit side)
Room temperature control			Thermostat by electronics	–
Safety equipment			Internal thermostat for fan motor. Frost protection thermostat.	Internal thermostat for fan motor. Abnormal discharge temperature protection
Installation data		mm		
Refrigerant piping size		(in)	Liquid line: φ6.35 (1/4") Gas line: φ15.88 (5/8")	
Connecting method			Flare piping	
Drain hose			(Connectable with VP16)	–
Insulation for piping			Necessary (both Liquid & Gas lines)	
Accessories			Mounting kit. Wireless remote controller. Drain hose	
Optional parts			–	

Notes (1) The data are measured at the following conditions.

Item	Indoor air temperature		Outdoor air temperature		Standards
	DB	WB	DB	WB	
Cooling	27°C	19°C	35°C	24°C	ISO-T1, JIS B8616
Heating	20°C	–	7°C	6°C	

(2) This packaged air-conditioner is manufactured and tested in conformity with the following standard. JIS B8616 "UNITARY AIR-CONDITIONERS"

(3) The operation data indicate when the air-conditioner is operated at 220/240V 50Hz.

(4) Indicates the value at mild mode.

Model FDKN258HEN-S1

Item		Model	FDKN258HEN-S1	
			FDKN258H	FDC258HEN3A
Nominal cooling capacity⁽¹⁾		W	5700	
Nominal heating capacity⁽¹⁾		W	6100	
Power source			1 Phase, 220/240V, 50Hz	
Operation data⁽³⁾	Cooling input	kW	2.03/2.14	
	Running current (Cooling)	A	9.3/9.3	
	Power factor (Cooling)	%	99/96	
	Heating input	kW	1.93/2.08	
	Running current (Heating)	A	9.0/9.1	
	Power factor (Heating)	%	97/95	
	Inrush current (L.R.A)	A	51	
	Noise level ⁽⁴⁾	dB(A)	Hi: 45 Lo: 38	52
Exterior dimensions				
Height × Width × Depth		mm	298 × 940 × 196	845 × 880 × 340
Net weight		kg	11	55
Refrigerant equipment				
Compressor type & Q'ty			-	RM5526GNE4 × 1
Motor		kW	-	1.9
Starting method			-	Line starting
Heat exchanger			Louver fins & inner grooved tubing	Slitted fins & bare tubing
Refrigerant control			Capillary tube	
Refrigerant			R22	
Quantity		kg	Holding charged	1.1 [Pre-charged up to the piping length of 5m]
Refrigerant oil		ℓ	-	0.7 (BARREL FREEZE 32SAM)
Defrost control			MC controlled de-icer	
High pressure control			High pressure switch	
Air handling equipment				
Fan type & Q'ty			Tangential fan × 1	Propeller fan × 1
Motor		W	40 × 1	55 × 1
Starting method			Line starting	Line starting
Air flow (Standard)		CMM	Hi:17 Lo:10	56
Fresh air intake			Unavailable	
Air filter, Q'ty			Long life filter ×2(washable)	
Shock & vibration absorber			Rubber sleeve (for fan motor)	Rubber mount (for compressor)
Electric heater		W	-	20 (Crank case heater)
Operation control				
Operation switch			Wireless remote control switch	- (Indoor unit side)
Room temperature control			Thermostat by electronics	-
Safety equipment				
			Internal thermostat for fan motor. Frost protection thermostat.	Internal thermostat for fan motor. Abnormal discharge temperature protection
Installation data		mm	Liquid line: φ9.52 (3/8") Gas line: φ15.88 (5/8")	
Refrigerant piping size		(in)		
Connecting method			Flare piping	
Drain hose			(Connectable with VP16)	-
Insulation for piping			Necessary (both Liquid & Gas lines)	
Accessories			Mounting kit. Wireless remote controller. Drain hose	
Optional parts			-	

Notes (1) The data are measured at the following conditions.

Operation	Item	Indoor air temperature		Outdoor air temperature		Standards
		DB	WB	DB	WB	
Cooling		27°C	19°C	35°C	24°C	ISO-T1, JIS B8616
Heating		20°C	-	7°C	6°C	

(2) This packaged air-conditioner is manufactured and tested in conformity with the following standard. JIS B8616 "UNITARY AIR-CONDITIONERS"

(3) The operation data indicate when the air-conditioner is operated at 220/240V 50Hz.

(4) Indicates the value at mild mode.

(2) Alternative refrigerant R407C use models

Model FDKNP208HEN-S

Item	Model	FDKNP208HEN-S	
		FDKN208H	FDCP208HEN3A
Nominal cooling capacity ⁽¹⁾	W	4850	
Nominal heating capacity ⁽¹⁾	W	5400	
Power source		1 Phase, 220/240V, 50Hz	
Operation data ⁽³⁾	Cooling input	kW	2.07/2.14
	Running current (Cooling)	A	9.5/9.6
	Power factor (Cooling)	%	99/93
	Heating input	kW	1.97/2.11
	Running current (Heating)	A	9.3/9.5
	Power factor (Heating)	%	96/93
	Inrush current (L.R.A)	A	44
	Noise level ⁽⁴⁾	dB(A)	Hi: 45 Lo: 38
Exterior dimensions			
Height × Width × Depth	mm	275 × 790 × 179	690 × 880 × 290
Net weight	kg	10	49
Refrigerant equipment			
Compressor type & Q'ty		-	RM5523HNE5 × 1
Motor	kW	-	1.7
Starting method		-	Line starting
Heat exchanger		Louver fins & inner grooved tubing	Slitted fins & bare tubing
Refrigerant control		Capillary tube	
Refrigerant		R407C	
Quantity	kg	Holding charged	0.98 [Pre-charged up to the piping length of 5m]
Refrigerant oil	ℓ	-	0.7 (MA32)
Defrost control		IC controlled de-icer	
High pressure control		High pressure switch	
Air handling equipment			
Fan type & Q'ty		Tangential fan × 1	Propeller fan × 1
Motor	W	26 × 1	55 × 1
Starting method		Line starting	Line starting
Air flow (Standard)	CMM	Hi:16 Lo:10	56
Fresh air intake		Unavailable	-
Air filter, Q'ty		Long life filter ×2(washable)	-
Shock & vibration absorber		Rubber sleeve (for fan motor)	Rubber mount (for compressor)
Electric heater	W	-	20 (Crank case heater)
Operation control			
Operation switch		Wireless remote control switch	- (Indoor unit side)
Room temperature control		Thermostat by electronics	-
Safety equipment		Internal thermostat for fan motor. Frost protection thermostat.	Internal thermostat for fan motor. Thermostat for discharge temperature. High pressure switch for protection
Installation data	mm		
Refrigerant piping size	(in)	Liquid line: φ6.35 (1/4") Gas line: φ15.88 (5/8")	
Connecting method		Flare piping	
Drain hose		(Connectable with VP16)	-
Insulation for piping		Necessary (both Liquid & Gas lines)	
Accessories		Mounting kit. Wireless remote controller. Drain hose	
Optional parts		-	

Notes (1) The data are measured at the following conditions.

Operation	Item	Indoor air temperature		Outdoor air temperature		Standards
		DB	WB	DB	WB	
Cooling		27°C	19°C	35°C	24°C	ISO-T1, JIS B8616
Heating		20°C	-	7°C	6°C	

(2) This packaged air-conditioner is manufactured and tested in conformity with the following standard. JIS B8616 "UNITARY AIR-CONDITIONERS"

(3) The operation data indicate when the air-conditioner is operated at 220/240V 50Hz.

(4) Indicates the value at mild mode.

Model FDKNP258HEN-S

Item		Model	FDKNP258HEN-S	
			FDKN258H	FDCP258HEN3A
Nominal cooling capacity⁽¹⁾		W	5700	
Nominal heating capacity⁽¹⁾		W	6100	
Power source			1 Phase, 220/240V, 50Hz	
Operation data⁽³⁾	Cooling input	kW	2.34/2.54	
	Running current (Cooling)	A	11.3/12.5	
	Power factor (Cooling)	%	94/85	
	Heating input	kW	2.08/2.33	
	Running current (Heating)	A	10.4/11.9	
	Power factor (Heating)	%	91/82	
	Inrush current (L.R.A)	A	51	
	Noise level ⁽⁴⁾	dB(A)	Hi: 45 Lo: 38	52
Exterior dimensions				
Height × Width × Depth		mm	298 × 940 × 196	845 × 880 × 340
Net weight		kg	11	55
Refrigerant equipment				
Compressor type & Q'ty			-	RM5526HNE5 × 1
Motor		kW	-	1.9
Starting method			-	Line starting
Heat exchanger			Louver fins & inner grooved tubing	Slitted fins & bare tubing
Refrigerant control			Capillary tube	
Refrigerant			R407C	
Quantity		kg	Holding charged	1.1 [Pre-charged up to the piping length of 5m]
Refrigerant oil		ℓ	-	0.7 (MA32)
Defrost control			IC controlled de-icer	
High pressure control			High pressure switch	
Air handling equipment				
Fan type & Q'ty			Tangential fan × 1	Propeller fan × 1
Motor		W	40 × 1	55 × 1
Starting method			Line starting	Line starting
Air flow (Standard)		CMM	Hi:17 Lo:10	56
Fresh air intake			Unavailable	
Air filter, Q'ty			Long life filter ×2(washable)	
Shock & vibration absorber			Rubber sleeve (for fan motor)	Rubber mount (for compressor)
Electric heater		W	-	20 (Crank case heater)
Operation control				
Operation switch			Wireless remote control switch	- (Indoor unit side)
Room temperature control			Thermostat by electronics	-
Safety equipment				
			Internal thermostat for fan motor. Frost protection thermostat.	Internal thermostat for fan motor. Thermostat for discharge temperature. High pressure switch for protection
Installation data		mm	Liquid line: φ9.52 (3/8") Gas line: φ15.88 (5/8")	
Refrigerant piping size		(in)		
Connecting method			Flare piping	
Drain hose			(Connectable with VP16)	-
Insulation for piping			Necessary (both Liquid & Gas lines)	
Accessories			Mounting kit. Wireless remote controller. Drain hose	
Optional parts			-	

Notes (1) The data are measured at the following conditions.

Operation	Item	Indoor air temperature		Outdoor air temperature		Standards
		DB	WB	DB	WB	
Cooling		27°C	19°C	35°C	24°C	ISO-T1, JIS B8616
Heating		20°C	12°C	7°C	6°C	

(2) This packaged air-conditioner is manufactured and tested in conformity with the following standard. JIS B8616 "UNITARY AIR-CONDITIONERS"

(3) The operation data indicate when the air-conditioner is operated at 220/240V 50Hz.

(4) Indicates the value at mild mode.

Model FDKNP308HEN-S

Item	Model	FDKNP308HEN-S	
		FDKN308H	FDCP308HEN3
Nominal cooling capacity⁽¹⁾	W	7100	
Nominal heating capacity⁽¹⁾	W	8000	
Power source		1 Phase, 220/240V, 50Hz	
Operation data⁽³⁾	Cooling input	kW	3.18/3.33
	Running current (Cooling)	A	14.8/15.2
	Power factor (Cooling)	%	98/91
	Heating input	kW	2.93/3.07
	Running current (Heating)	A	13.8/14.2
	Power factor (Heating)	%	97/90
	Inrush current (L.R.A)	A	95
	Noise level ⁽⁴⁾	dB(A)	Hi 46 Lo:40
Exterior dimensions			
Height × Width × Depth	mm	298 × 1155 × 196	845 × 880 × 340
Net weight	kg	13.5	76
Refrigerant equipment			
Compressor type & Q'ty		-	GT-A5534HN41 × 1
Motor	kW	-	2.5
Starting method		-	Line starting
Heat exchanger		Louver fins & inner grooved tubing	Slitted fins & bare tubing
Refrigerant control		Capillary tube	
Refrigerant		R407C	
Quantity	kg	Holding charged	1.75 [Pre-charged up to the piping length of 5m]
Refrigerant oil	ℓ	-	1.45 (MA32)
Defrost control		IC controlled de-icer	
High pressure control		High pressure switch	
Air handling equipment			
Fan type & Q'ty		Tangential fan × 1	Propeller fan × 1
Motor	W	40 × 1	55 × 1
Starting method		Line starting	Line starting
Air flow (Standard)	CMM	Hi:21 Lo:15	58
Fresh air intake		Unavailable	-
Air filter, Q'ty		Long life filter ×3(washable)	-
Shock & vibration absorber		Rubber sleeve (for fan motor)	Rubber mount (for compressor)
Electric heater	W	-	33 (Crank case heater)
Operation control			
Operation switch		Wireless remote control switch	- (Indoor unit side)
Room temperature control		Thermostat by electronics	-
Safety equipment		Internal thermostat for fan motor. Frost protection thermostat.	Internal thermostat for fan motor. Thermostat for discharge temperature. High pressure switch for protection
Installation data			
Refrigerant piping size	mm (in)	Liquid line: φ9.52 (3/8") Gas line: φ15.88 (5/8")	
Connecting method		Flare piping	
Drain hose		(Connectable with VP16)	-
Insulation for piping		Necessary (both Liquid & Gas lines)	
Accessories		Mounting kit. Wireless remote controller. Drain hose	
Optional parts		-	

Notes (1) The data are measured at the following conditions.

Item	Indoor air temperature		Outdoor air temperature		Standards
	DB	WB	DB	WB	
Cooling	27°C	19°C	35°C	24°C	ISO-T1, JIS B8616
Heating	20°C	-	7°C	6°C	

(2) This packaged air-conditioner is manufactured and tested in conformity with the following standard. JIS B8616 "UNITARY AIR-CONDITIONERS"

(3) The operation data indicate when the air-conditioner is operated at 220/240V 50Hz.

(4) Indicates the value at mild mode.

Model FDKNP308HES-S

Item		Model	FDKNP308HES-S	
			FDKN308H	FDCP308HES3
Nominal cooling capacity⁽¹⁾		W	7100	
Nominal heating capacity⁽¹⁾		W	8000	
Power source			3 Phase, 380/415V, 50Hz	
Operation data⁽³⁾	Cooling input	kW	3.10/3.25	
	Running current (Cooling)	A	5.4/5.7	
	Power factor (Cooling)	%	87/79	
	Heating input	kW	2.95/3.09	
	Running current (Heating)	A	5.4/5.7	
	Power factor (Heating)	%	82/75	
	Inrush current (L.R.A)	A	45	
	Noise level ⁽⁴⁾	dB(A)	Hi 46 Lo:40	52
Exterior dimensions				
Height × Width × Depth		mm	298 × 1155 × 196	845 × 880 × 340
Net weight		kg	13.5	76
Refrigerant equipment				
Compressor type & Q'ty			-	GT-A5534HS41 × 1
Motor		kW	-	2.5
Starting method			-	Line starting
Heat exchanger			Louver fins & inner grooved tubing	Slitted fins & bare tubing
Refrigerant control			Capillary tube	
Refrigerant			R407C	
Quantity		kg	Holding charged	1.75 [Pre-charged up to the piping length of 5m]
Refrigerant oil		ℓ	-	1.45 (MA32)
Defrost control			IC controlled de-icer	
High pressure control			High pressure switch	
Air handling equipment				
Fan type & Q'ty			Tangential fan × 1	Propeller fan × 1
Motor		W	40 × 1	55 × 1
Starting method			Line starting	Line starting
Air flow (Standard)		CMM	Hi:21 Lo:15	58
Fresh air intake			Unavailable	
Air filter, Q'ty			Long life filter ×3(washable)	
Shock & vibration absorber			Rubber sleeve (for fan motor)	Rubber mount (for compressor)
Electric heater		W	-	33 (Crank case heater)
Operation control				
Operation switch			Wireless remote control switch	- (Indoor unit side)
Room temperature control			Thermostat by electronics	-
Safety equipment				
			Internal thermostat for fan motor. Frost protection thermostat.	Internal thermostat for fan motor. Thermostat for discharge temperature. High pressure switch for protection
Installation data				
Refrigerant piping size		mm (in)	Liquid line: φ9.52 (3/8") Gas line: φ15.88 (5/8")	
Connecting method			Flare piping	
Drain hose			(Connectable with VP16)	-
Insulation for piping			Necessary (both Liquid & Gas lines)	
Accessories			Mounting kit. Wireless remote controller. Drain hose	
Optional parts			-	

Notes (1) The data are measured at the following conditions.

Operation	Item	Indoor air temperature		Outdoor air temperature		Standards
		DB	WB	DB	WB	
Cooling		27°C	19°C	35°C	24°C	ISO-T1, JIS B8616
Heating		20°C	-	7°C	6°C	

(2) This packaged air-conditioner is manufactured and tested in conformity with the following standard. JIS B8616 "UNITARY AIR-CONDITIONERS"

(3) The operation data indicate when the air-conditioner is operated at 380/415V 50Hz.

(4) Indicates the value at mild mode.

12.2.2 Renge of usage & limitations

Item	Models	FDKN (P) 208, 258 type	FDKNP308 type
Indoor return air temperature (Upper, lower limits)	Refer to the selection chart		
Outdoor air temperature (Upper, lower limits)			
Refrigerant line (one way) length	Max. 30 m	Max. 50 m	
Vertical height difference between outdoor unit and indoor unit	Max. 20 m (Outdoor unit is higher) Max. 15 m (Outdoor unit is lower)	Max. 30 m (Outdoor unit is higher) Max. 15 m (Outdoor unit is lower)	
Power source voltage	Rating \pm 10%		
Voltage at starting	Min. 85% of rating		
Frequency of ON-OFF cycle	Max. 10 times/h		
ON and OFF interval	Min. 3 minutes		

12.2.3 Exterior dimensions

(1) Indoor unit
Model FDKN208H

Unit : mm

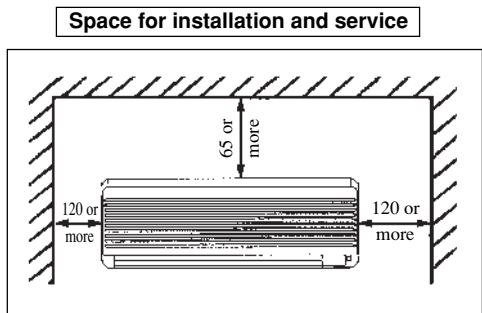
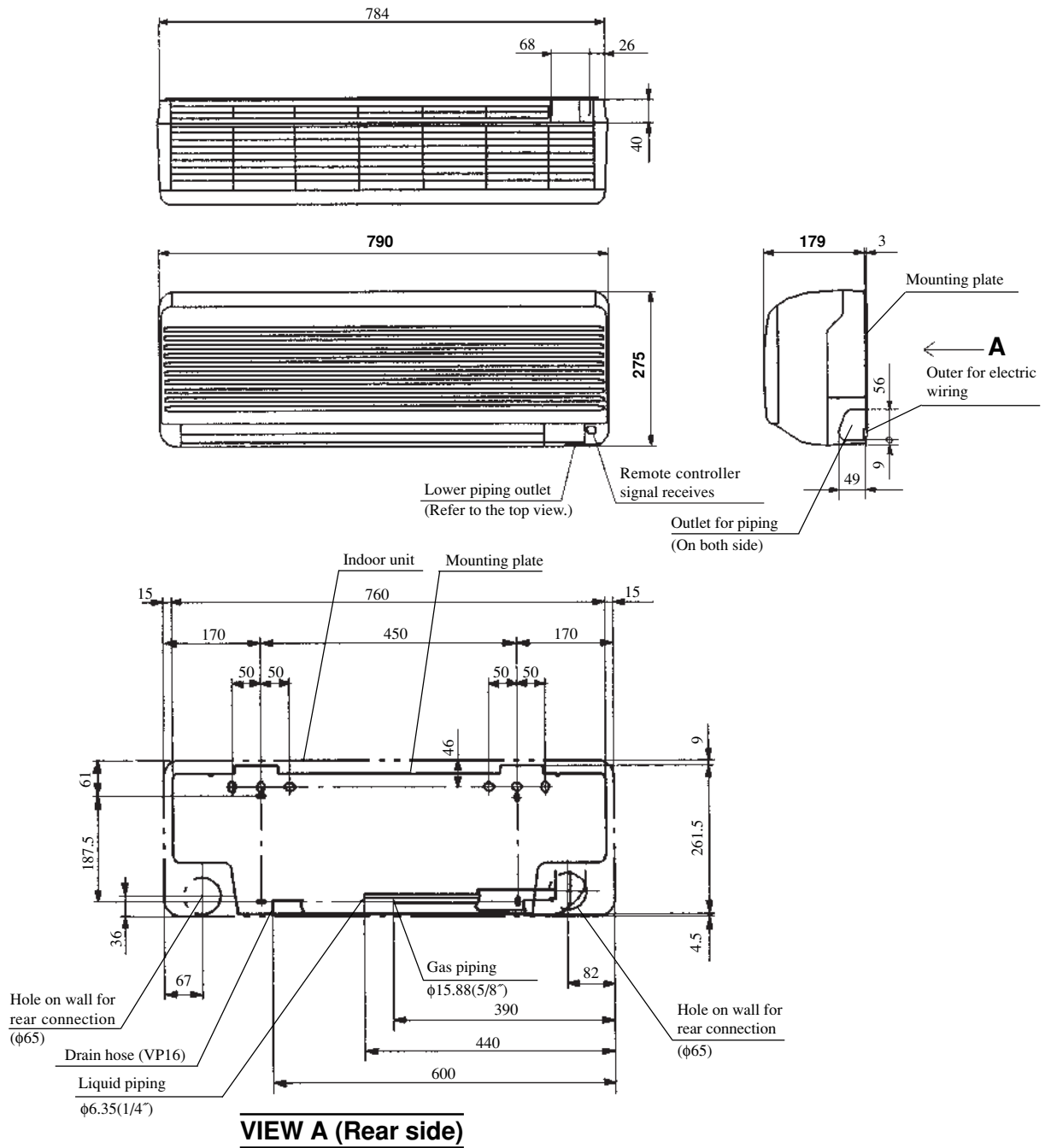

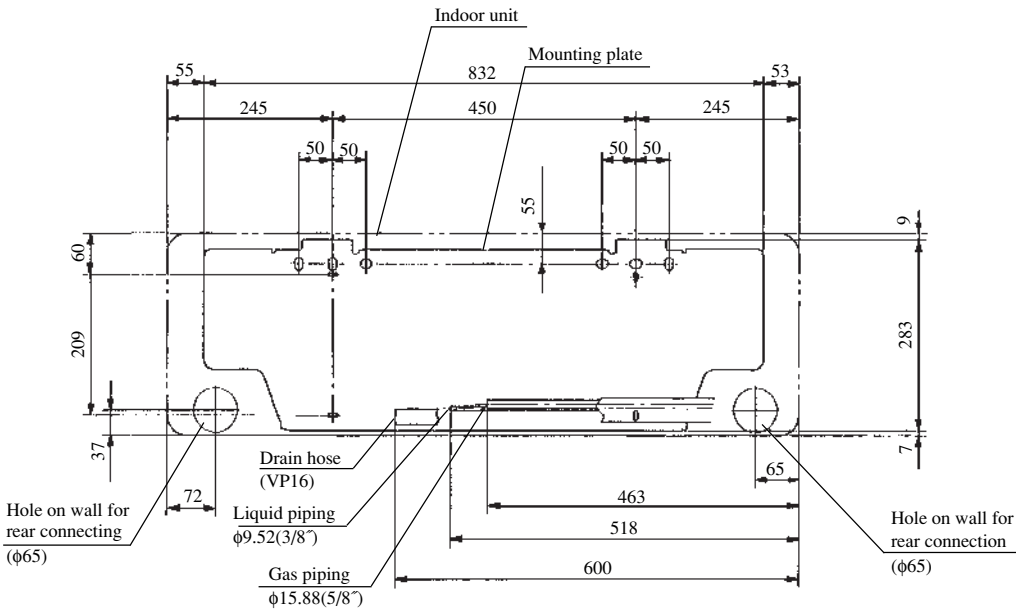
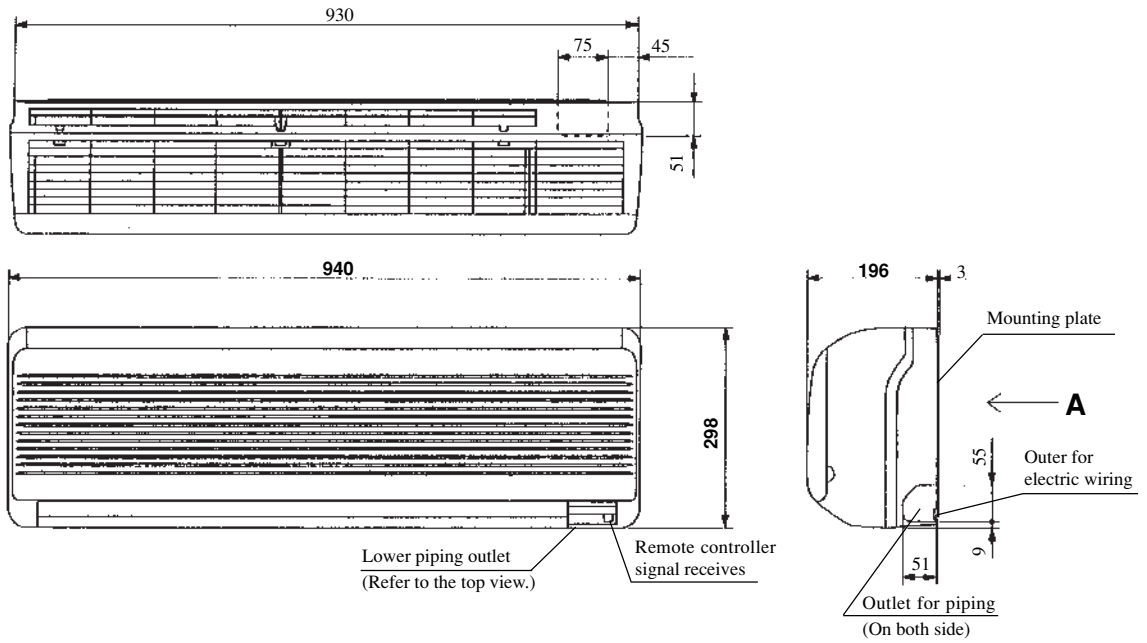

VIEW A (Rear side)

Space for installation and service

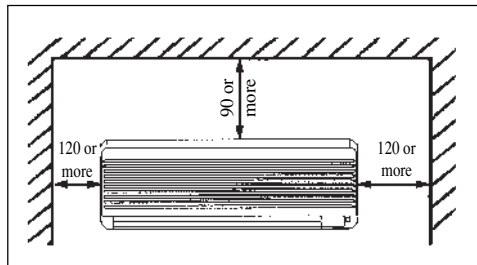

Model FDKN308H

Unit : mm

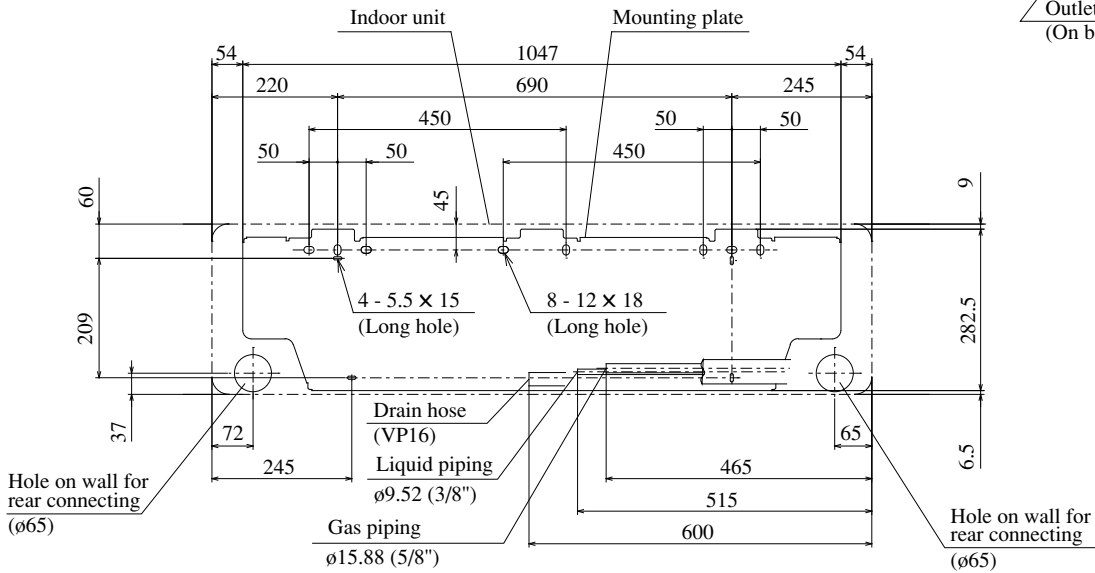
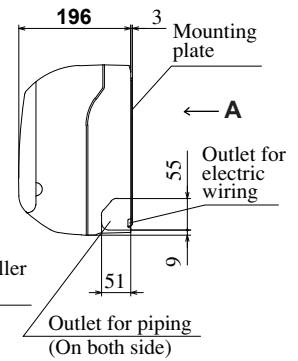
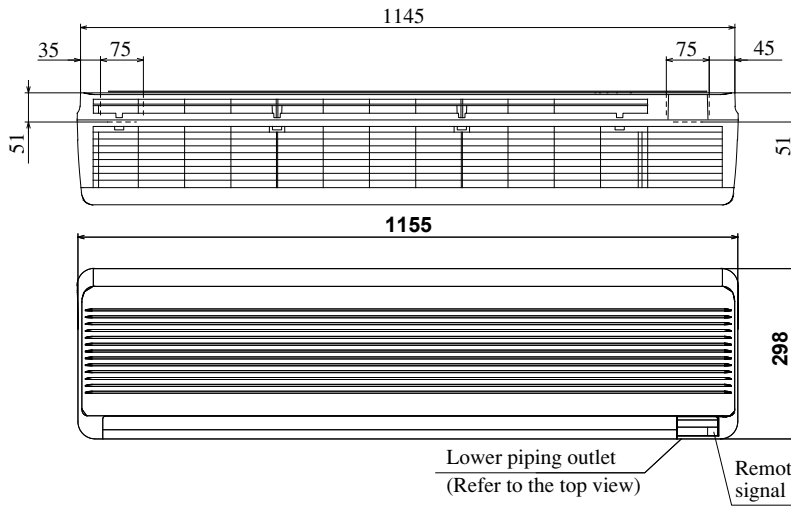

VIEW A (Rear side)

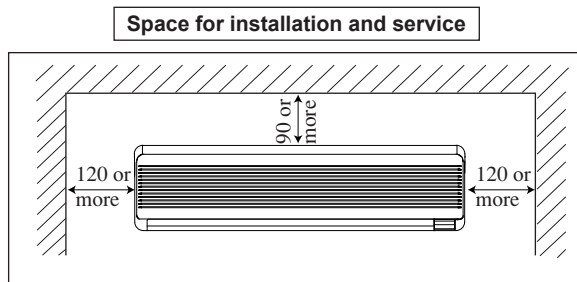

(2) Wireless remote controller

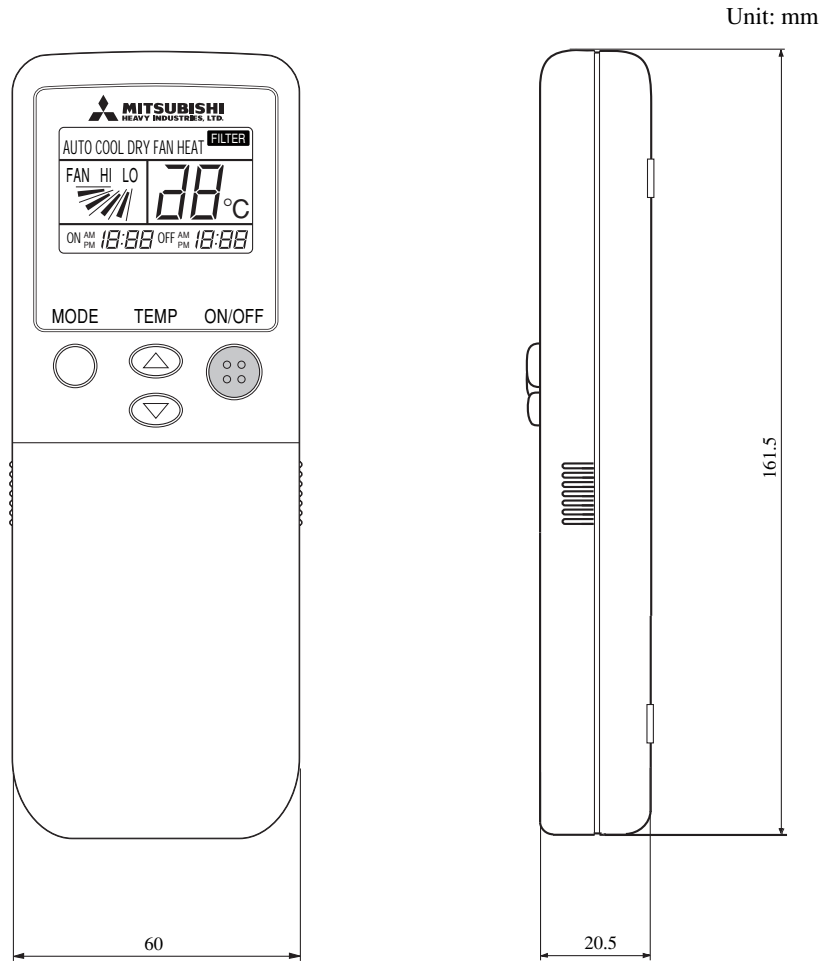

(3) Indication board of indoor unit

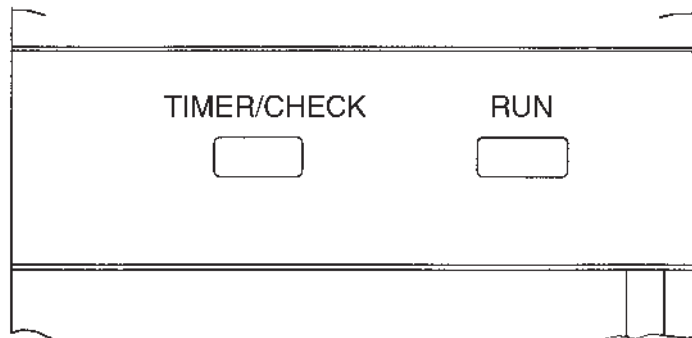

(4) Outdoor unit

**Models FDC208HEN3A
FDCP208HEN3A**

Unit : mm

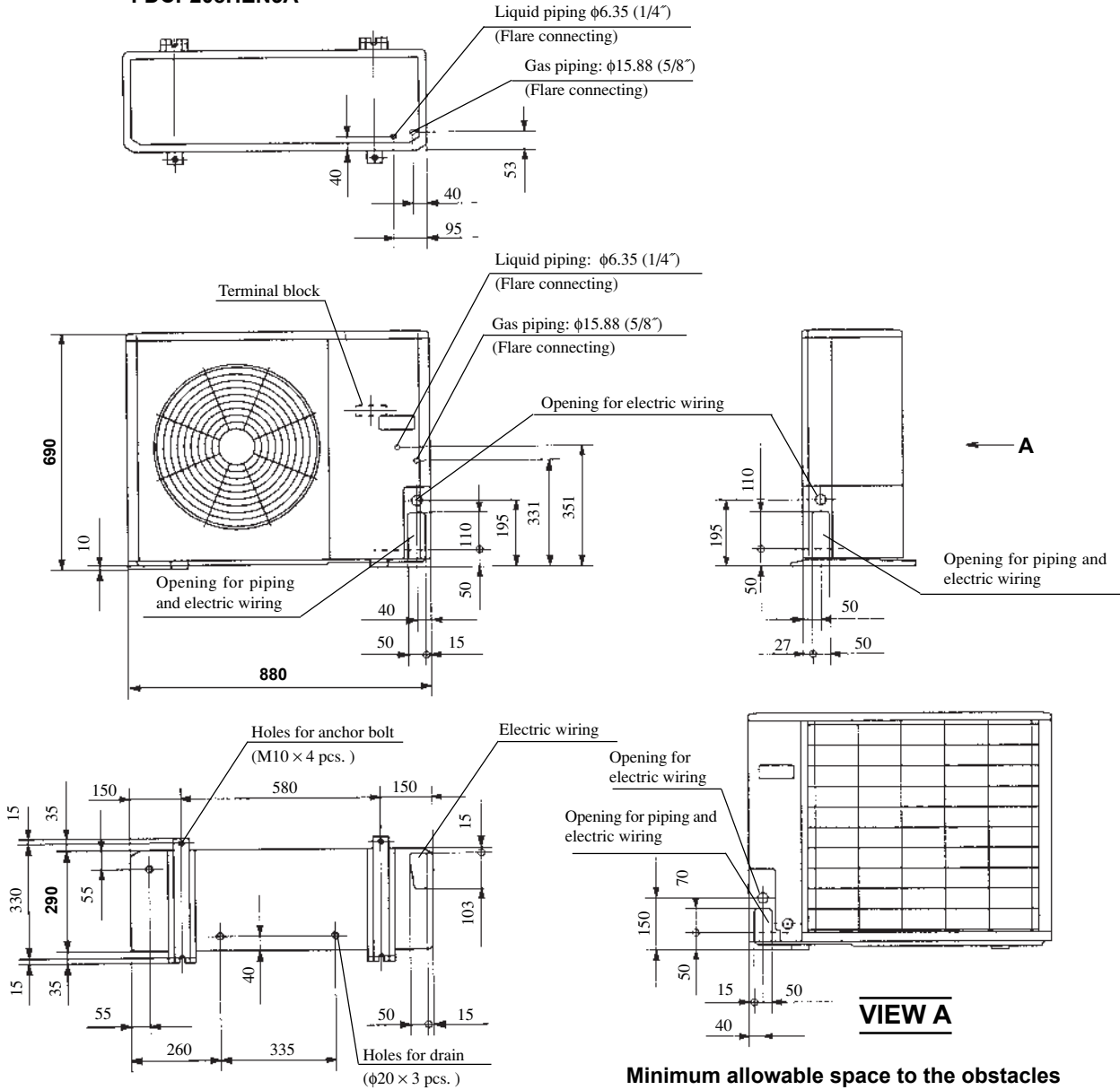

Required space for maintenance and air flow

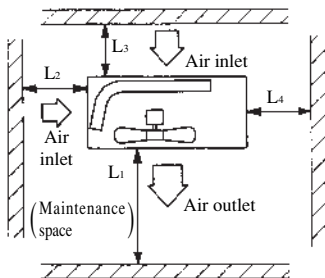

Minimum allowable space to the obstacles

Unit: mm

Installation type Mark	Installation type		
	I	II	III
L1	Open	Open	500
L2	300	5	Open
L3	100	150	100
L4	5	5	5

Notes

- (1) Avoid the location where four sides are entirely surrounded by walls.
- (2) Fix the unit by anchor bolts without fail. Restrict the protrusion length of anchor bolt to 15 mm and under.
- (3) When strong wind blows against the unit, direct the discharge port at a right angle to the wind direction.
- (4) Secure the space of 1 m and over at the top of unit.
- (5) Make the height of obstruction wall in front of discharge port lower than the height of unit.

**Models FDC258HEN3A
FDCP258HEN3A, 308HEN3, 308HES3**

Unit: mm

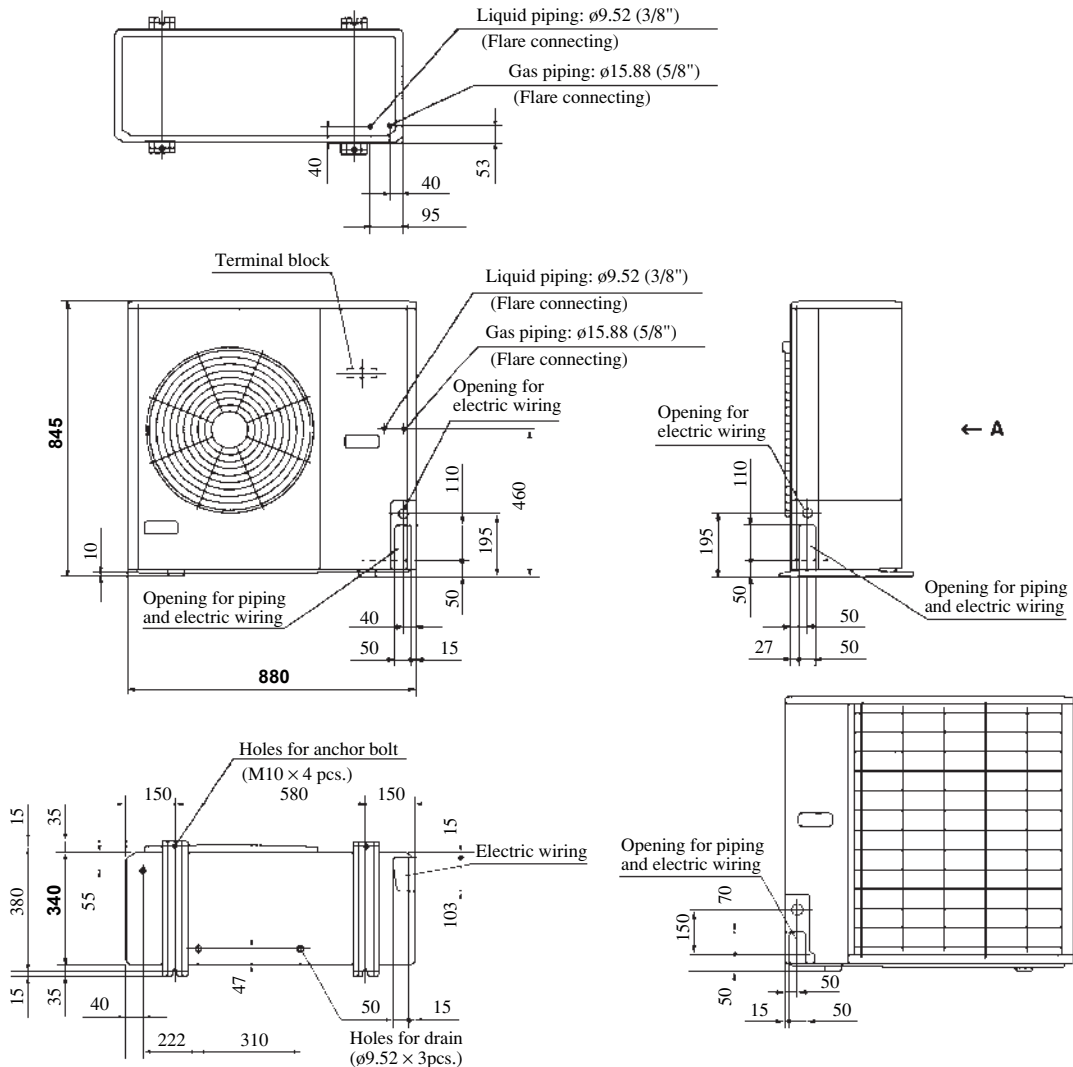

VIEW A

Required space for maintenance and air flow

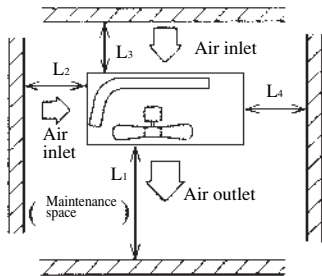

Minimum allowable space to the obstacles

Unit:mm

Mark	Installation type	Unit:mm		
		I	II	III
L ₁	Open	Open	Open	500
L ₂	300	5	Open	Open
L ₃	100	150	100	100
L ₄	5	5	5	5

Notes

- (1) Avoid the location where four sides are entirely surrounded by walls.
- (2) Fix the unit by anchor bolts without fail. Restrict the protrusion length of anchor bolt to 15 mm and under.
- (3) When strong wind blows against the unit, direct the discharge port at a right angle to the wind direction.
- (4) Secure the space of 1 m and over at the top of unit.
- (5) Make the height of obstruction wall in front of discharge port lower than the height of unit.

12.2.4 Exterior appearance

- (1) Indoor unit
 Models All models

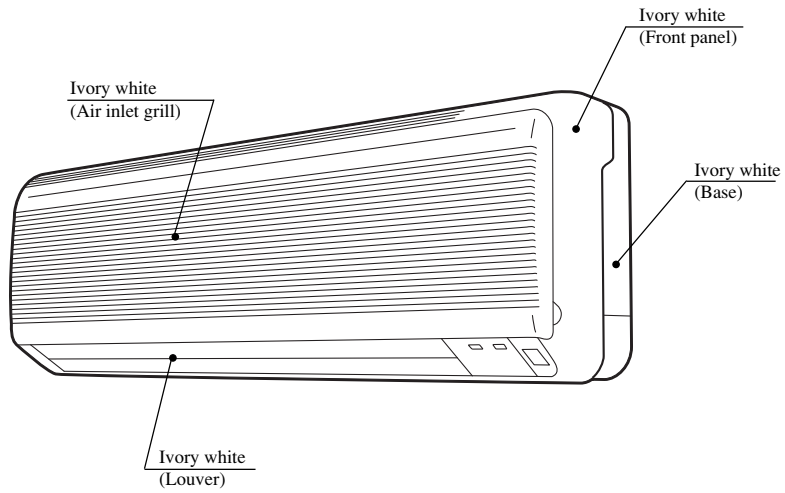

- (2) Outdoor unit
 Models FDC208HEN3A
 FDCP208HEN3A

- Models FDC258HEN3A
 FDCP258HEN3A, 308HEN3, 308HES3

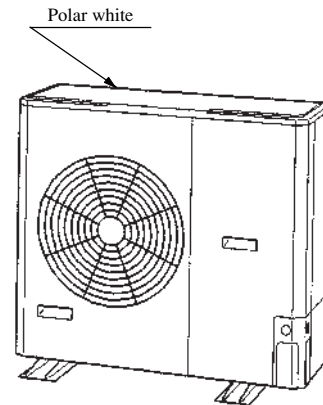
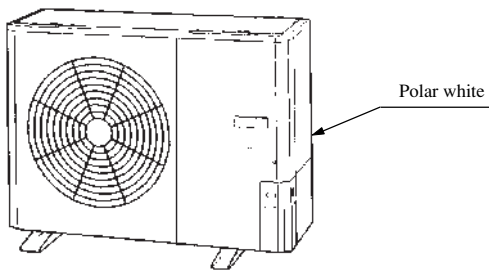

12.2.5 Piping system

Models **FDKN208HEN-S1, 258HEN-S1, FDKNP208HEN-S, 258HEN-S**

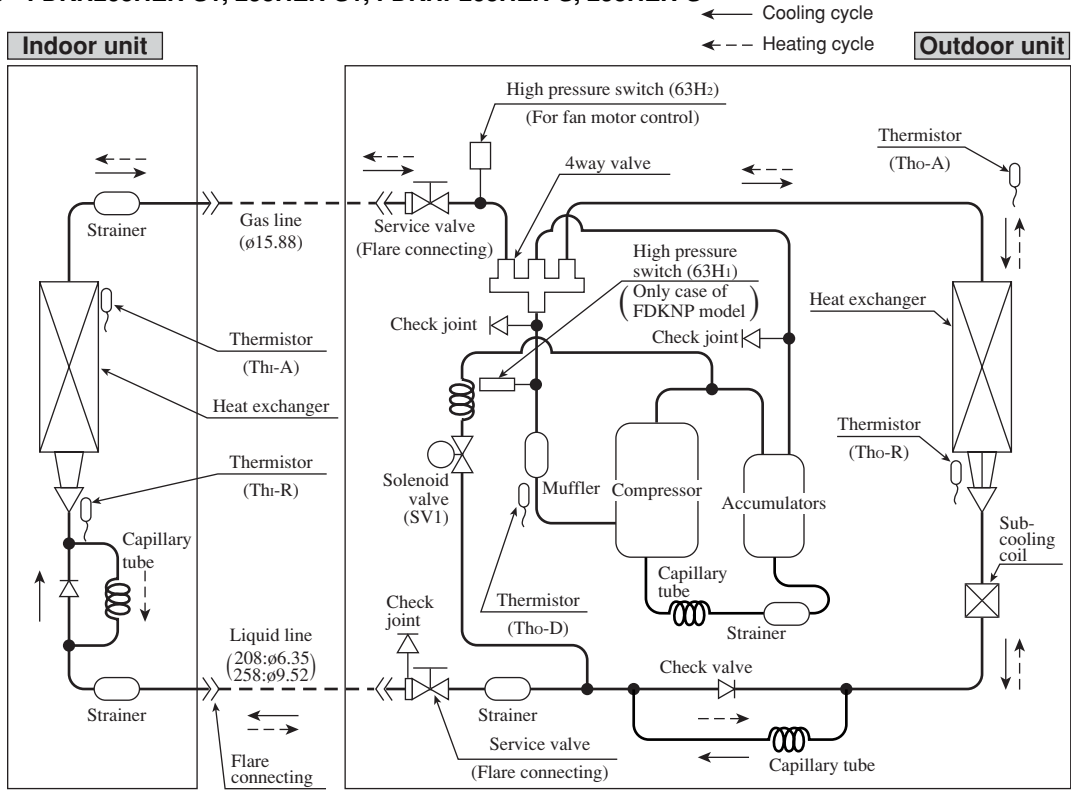

Models **FDKNP308HEN-S, 308HES-S**

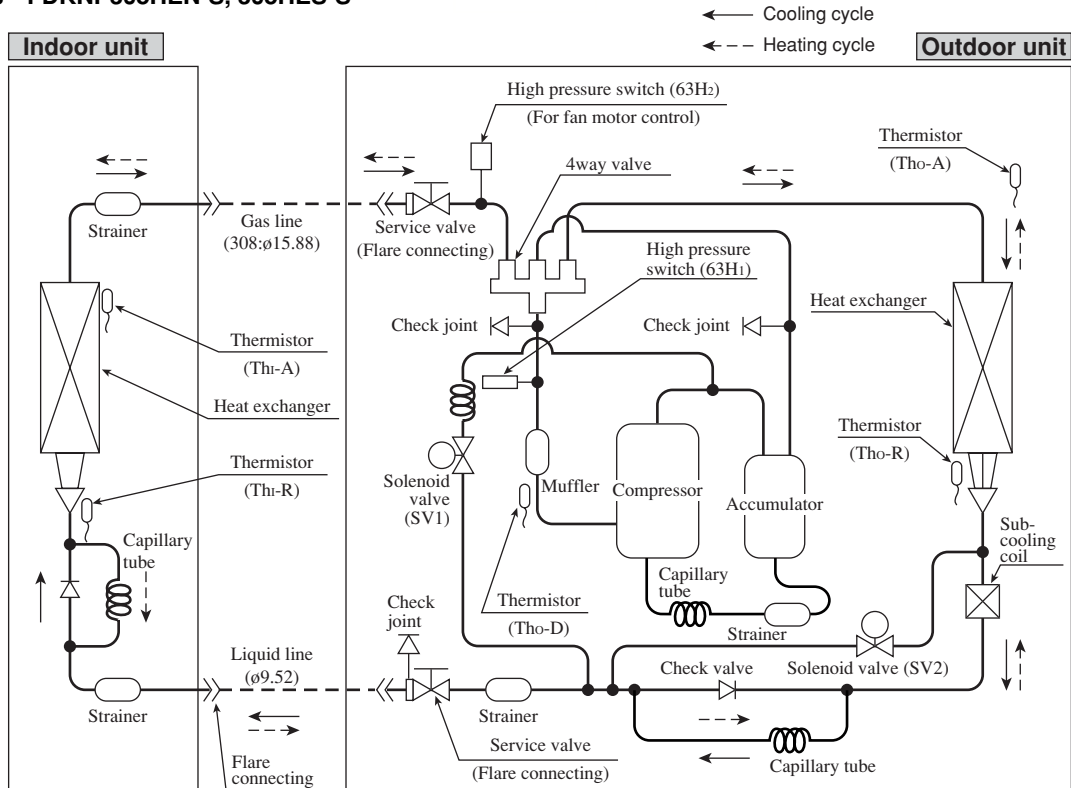

Preset point of the protective devices

Parts name	Mark	Equipped unit	FDKN208, 258 type	FDKNP208~308 type
Thermistor (for protection over loading in heating)	Th _i -R	Indoor unit	OFF 68 °C ON 61 °C	
Thermistor (for frost prevention)			OFF 2.5 °C ON 10 °C	
Thermistor (for detecting discharge pipe temp.)	Th _o -D	Outdoor unit	OFF 135 °C ON 90 °C	
Thermistor (for detecting heat exchanger temp.)	Th _o -R	Outdoor unit	OFF 70 °C ON 60 °C	
High pressure switch (for controlling FMo)	63H ₂	Outdoor unit	OFF 2.5MPa (25.5kgf/cm ²) ON 2.06MPa (21kgf/cm ²)	
High pressure switch (for protection)	63H ₁	Outdoor unit	—	OFF 3.24MPa (33kgf/cm ²) ON 2.65MPa (27kgf/cm ²)

12.2.6 Selection chart

Correct the cooling and heating capacity in accordance with the conditions as follows. The net cooling and heating capacity can be obtained in the following way.

Net capacity = Capacity shown on specification × Correction factors as follows.

- (1) Coefficient of cooling and heating capacity in relation to temperatures
 Models FDKN208HEN-S1, 258HENS-1, FDKNP208HEN-S, 258HEN-S

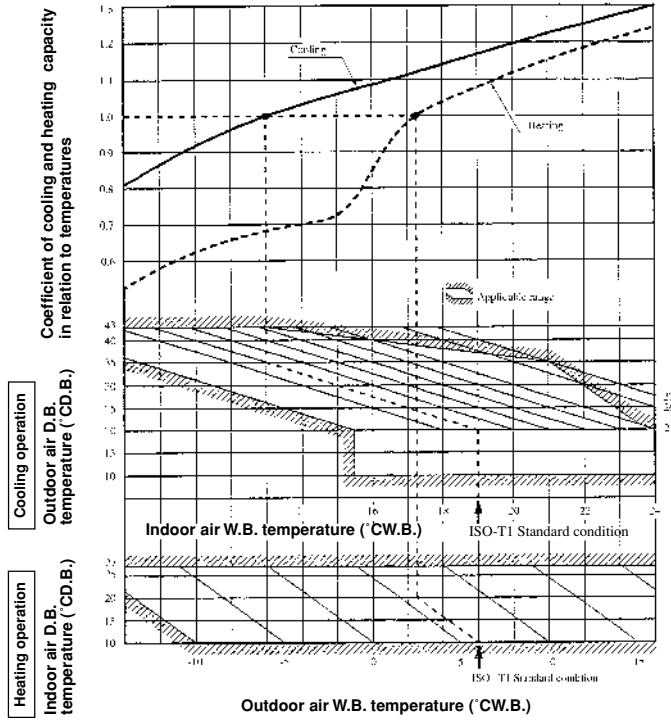

- Models FDKN308HEN-S, 308HES-S

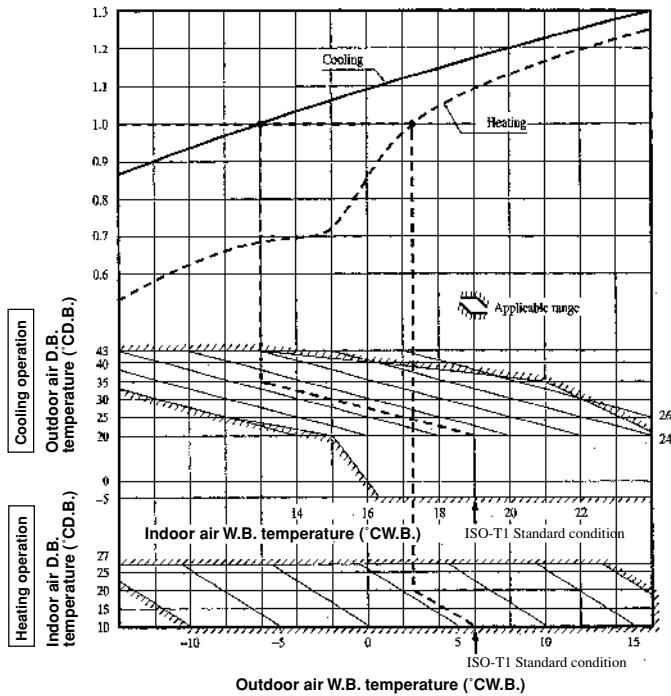

Table of bypass factor

Model Item		FDKN (P) 208 type	FDKN (P) 258 type	FDKNP308 type
		Air flow	Hi	0.03

(2) Correction of cooling and heating capacity in relation to air flow rate control (fan speed)

Coefficient: 1.00 at High, 0.95 at Low

(3) Correction of cooling and heating capacity in relation to one way length of refrigerant piping

It is necessary to correct the cooling and heating capacity in relation to the one way equivalent piping length between the indoor and outdoor units.

Equivalent piping length ⁽¹⁾ m		5	10	15	20	25	30	35	40	45	50	55
Heating		1.0	1.0	1.0	1.0	1.0	0.995	0.995	0.99	0.99	0.985	0.985
Cooling	FDKN (P) 208 type	1.0	0.995	0.995	0.99	0.985	0.985	0.98	—	—	—	—
	FDKN (P) 258 type	1.0	0.995	0.99	0.985	0.98	0.975	0.97	—	—	—	—
	FDKNP 308 type	1.0	0.99	0.98	0.97	0.96	0.95	0.94	0.93	0.92	0.91	0.9

Note (1) Equivalent piping length can be obtained by calculating as follows.
 208, 258, 308 series [φ15.88(5/8")]: Equivalent piping length = Real piping length + (0.10 × Number of bends in piping)
 [Equivalent piping length < Limitation length of piping + 5m]

(4) When the outdoor unit is located at a lower height than the indoor unit in cooling operation and when the outdoor unit is located at a higher height than the indoor unit in heating operation, the following values should be subtracted from the values in the above table.

Height difference between the indoor unit and outdoor unit in the vertical height difference	5m	10m	15m	20m	25m	30m
Adjustment coefficient	0.01	0.02	0.03	0.04	0.05	0.06

Piping length limitations

Item	Model	
	FDKN(P) 208, 258 type	FDKNP308 type
Max. one way piping length	30m	50m
Max. vertical height difference	20m (Outdoor unit is higher) 15m (Outdoor unit is lower)	30m (Outdoor unit is higher) 15m (Outdoor unit is lower)

Note(1) Values in the table indicate the one way piping length between the indoor and outdoor units.

How to obtain the cooling capacity

Example: The net cooling capacity of the model FDKNP308HEN-S with the air flow “High”, the piping length of 15m, the outdoor unit located 5m lower than the indoor unit, indoor wet-bulb temperature at 19.0 °C and outdoor dry-bulb temperature 35 °C is

$$\text{Net cooling capacity} = \underset{\substack{\uparrow \\ \text{FDKNP308HEN-S}}}{7100} \times \underset{\substack{\uparrow \\ \text{Air flow} \\ \text{“High”}}}{1.00} \times \underset{\substack{\uparrow \\ \text{Length 15m.} \\ \text{Height difference 5 m}}}{(0.98 - 0.01)} \times \underset{\substack{\uparrow \\ \text{Factor by air} \\ \text{temperatures}}}{1.0} = \mathbf{6887 \text{ w}}$$

12.2.7 Noise level

Notes (1) The data are based on the following conditions.

Ambient air temperature:
 Indoor unit 27°C DB, 19°C WB
 Outdoor unit 35°C DB,

Indoor unit
 Measured based on JIS B 8616
 Mike position as below



Outdoor unit
 Measured based on JIS B 8616
 Mike position: at highest noise level
 in position as below
 Distance from front side 1 m
 Height 1 m

(2) The data in the chart are measured in an unechoic room.

(3) The noise levels measured in the field are usually higher than the data because of reflection.

(1) Indoor unit

Model FDKN208H

Noise level 45dB (A) at HIGH
 38dB (A) at LOW

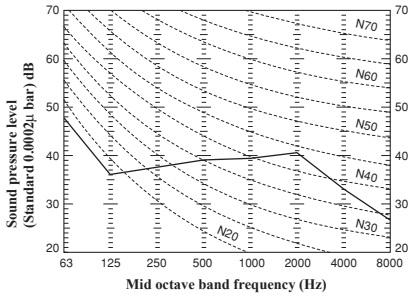

Model FDKN258H

Noise level 45dB (A) at HIGH
 38dB (A) at LOW

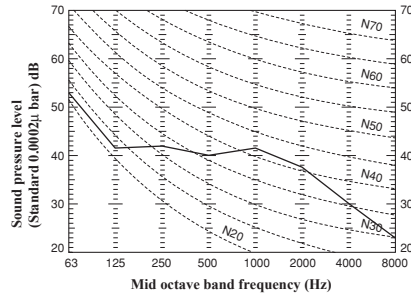

Model FDKN308H

Noise level 46dB (A) at HIGH
 40dB (A) at LOW

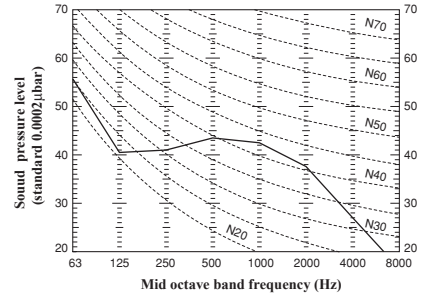

(2) Outdoor unit

Model FDC208HEN3A

Noise level 52dB (A)

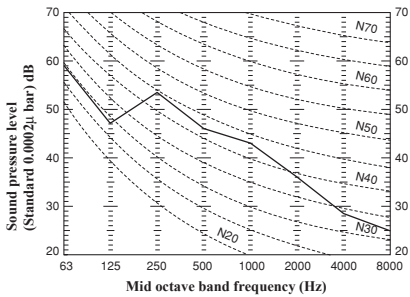

Model FDC258HEN3A

Noise level 52dB (A)

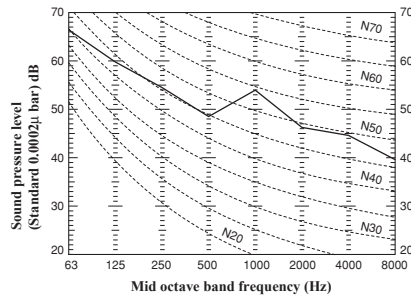

Model FDCP208HEN3A

Noise level 52dB (A)

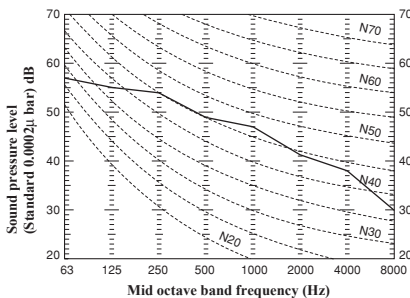

Model FDCP258HEN3A

Noise level 52dB (A)

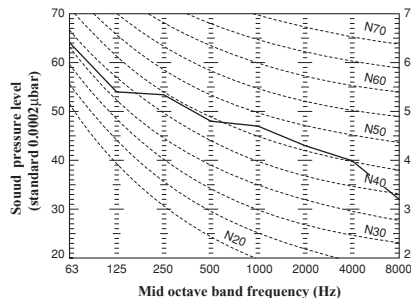

Models FDCP308HEN3, 308HES3

Noise level 52dB (A)

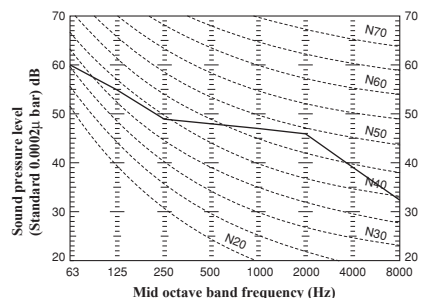

12.3 ELECTRICAL DATA

12.3.1 Electrical wiring

Model FDKN208HEN-S1

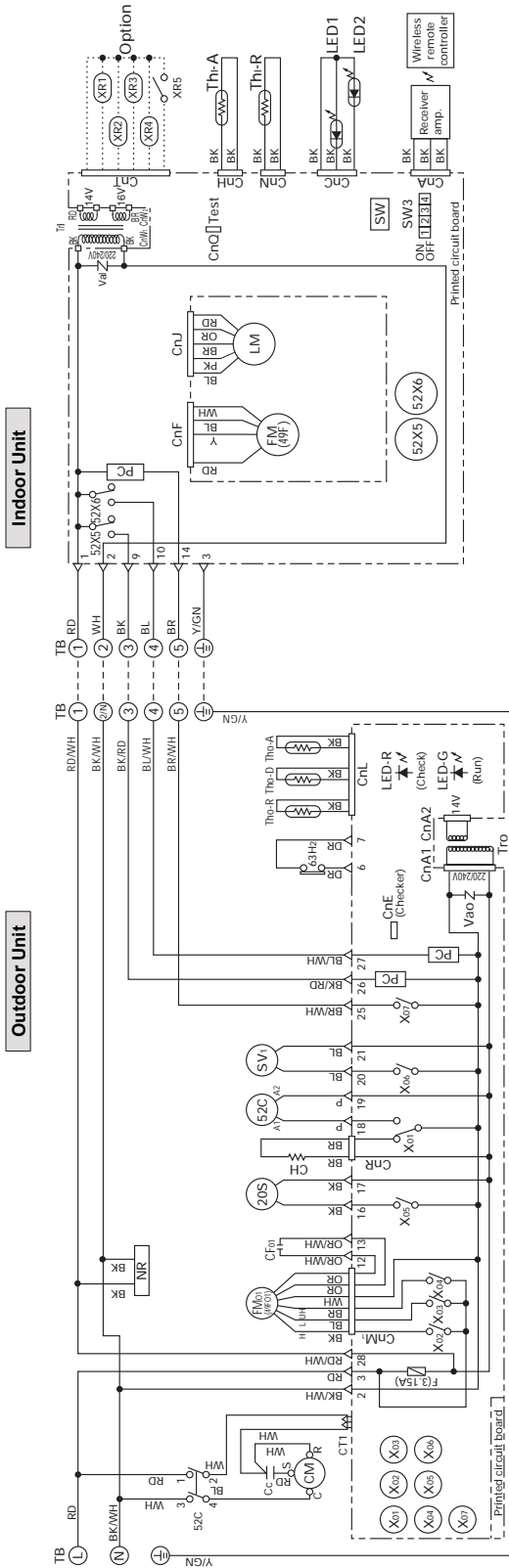

Color mark

Mark	Color	Mark	Color
BK	Black	BK/RD	Black/Red
BL	Blue	BK/WH	Black/White
BR	Brown	BL/WH	Blue/White
GR	Gray	BR/WH	Brown/White
OR	Orange	OR/WH	Orange/White
PK	Pink	RD/WH	Red/White
RD	Red	Y/GN	Yellow/Green
WH	White		
Y	Yellow		

Meaning of marks

Mark	Parts name	Mark	Parts name
CC	Capacitor for CM	Th-R	Thermistor
CCo	Capacitor for FMO	Tho-A	Thermistor
CH	Crankcase heater	Tho-D	Thermistor
CM	Compressor motor	Tho-R	Thermistor
CnA ~ W	Connector (□mark)	Tro	Transformer
CT1	Current sensor	Val	Valve solenoid
F	Fuse	Vao	Varistor
FMI	Fan motor (Indoor unit)	Z	4-way valve solenoid
FMO	Fan motor (Outdoor unit)	20S	Internal thermostat for FMI
LED1	Indication lamp (Green - Run)	49F1	Internal thermostat for FMO
LED2	Indication lamp (Yellow - Timer/Check)	49Fo	Magnetic contactor for CM
LM	Louver motor	52C	Auxiliary relay
NR	Surge suppressor	52X5, 6	Auxiliary relay
PC	Photo coupler	X01~07	High pressure switch (for control)
SV1	Solenoid coil (for control)	63Hz	Terminal (F)
SW	Switch (ON/OFF)	LED-G	Connector
SW3	Changeover switch	LED-R	Indication lamp (Green)
TB	Terminal block (○mark)		Indication lamp (Red)
Th-A	Thermistor		

Power source
1 Phase 220/240V 50Hz

Model FDKN258HEN-S1

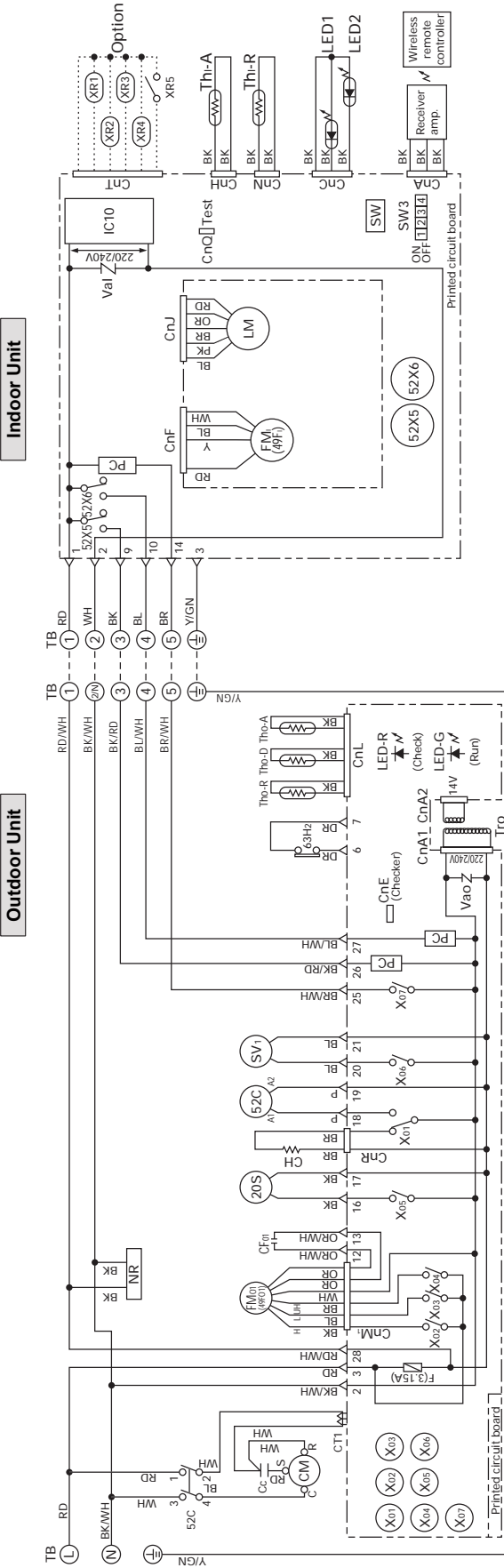

Color mark

Mark	Color	Mark	Color
BK	Black	BK/RD	Black/Red
BL	Blue	BK/WH	Black/White
BR	Brown	BL/WH	Blue/White
GR	Gray	BR/WH	Brown/White
OR	Orange	OR/WH	Orange/White
PK	Pink	RD/WH	Red/White
RD	Red	Y/GN	Yellow/Green
WH	White		
Y	Yellow		

Meaning of marks

Mark	Parts name	Mark	Parts name
CC	Capacitor for CM	Thi-R	Thermistor
CFo	Capacitor for FMo	Tho-A	Thermistor
CH	Crankcase heater	Tho-D	Thermistor
CM	Compressor motor	Tho-R	Thermistor
CnA ~ W	Connector (□mark)	TrO	Transformer
CT1	Current sensor	Val	Valistor
F	Fuse	Vao	4-way valve solenoid
FMI	Fan motor (Indoor unit)	20S	Internal thermostat for FMi
FMo	Fan motor (Outdoor unit)	49F1	Internal thermostat for FMo
LED1	Indication lamp (Green - Run)	49Fo	Magnetic contactor for CM
LED2	Indication lamp (Yellow - Timer/Check)	52C	Auxiliary relay
LM	Louver motor	52X5, 6	High pressure switch (for control)
NR	Surge suppressor	X01-07	Terminal (F)
PC	Photo coupler	63Hz	Connector
SV1	Solenoid coil (for control)	LED-G	Indication lamp (Green)
SW	Switch (ON/OFF)	LED-R	Indication lamp (Red)
SW3	Changeover switch		
TB	Terminal block (○mark)		
Thi-A	Thermistor		

Power source
1 Phase 220/240V 50Hz

Model FDKNP208HEN-S

Power source
1 Phase 220/240V 50Hz

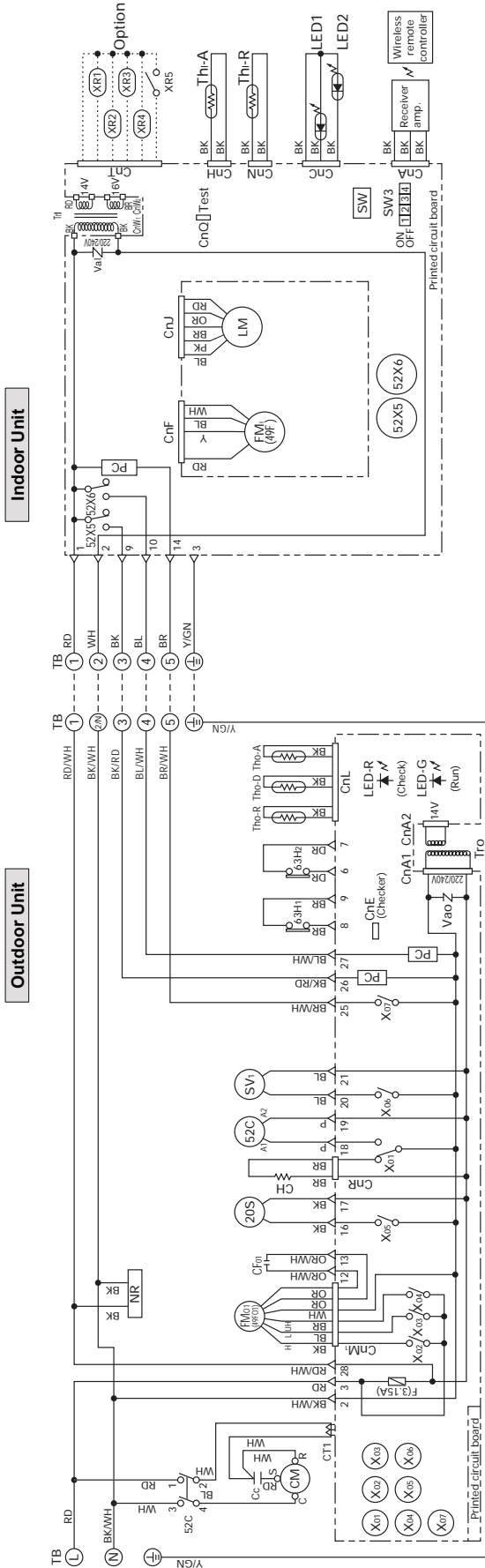

Meaning of marks

Mark	Parts name	Mark	Parts name
CC	Capacitor for CM	Th-R	Thermistor
CFo	Capacitor for FMo	Tho-A	Thermistor
CH	Crankcase heater	Tho-D	Thermistor
CM	Compressor motor	Tho-R	Thermistor
CnA ~ W	Connector (□mark)	Tro	Transformer
CT1	Current sensor	Val	Valvistor
F	Fuse	Vao	4-way valve solenoid
FMi	Fan motor (Indoor unit)	20S	Internal thermostat for FMi
FMo	Fan motor (Outdoor unit)	49F1	Internal thermostat for FMo
LED1	Indication lamp (Green - Run)	49Fo	Magnetic contactor for CM
LED2	Indication lamp (Yellow - Timer/Check)	52C	Auxiliary relay
LM	Louver motor	52X5, 6	Photo coupler
NR	Surge suppressor	PC	High pressure switch (for protection)
X01~07	Auxiliary relay	63H1	High pressure switch (for control)
SV1	Solenoid coil (for control)	63H2	Terminal (F)
SW	Switch (ON/OFF)	LED-G	Indication lamp (Green)
SW3	Changeover switch	LED-R	Indication lamp (Red)
TB	Terminal block (○mark)		
Thi-A	Thermistor		

Color mark

Mark	Color	Mark	Color
BK	Black	BK/RD	Black/Red
BL	Blue	BK/WH	Black/White
BR	Brown	BL/WH	Blue/White
GR	Gray	BR/WH	Brown/White
OR	Orange	OR/WH	Orange/White
PK	Pink	RD/WH	Red/White
RD	Red	Y/GN	Yellow/Green
WH	White		
Y	Yellow		

Model FDKNP258HEN-S

Power source
1 Phase 220/240V 50Hz

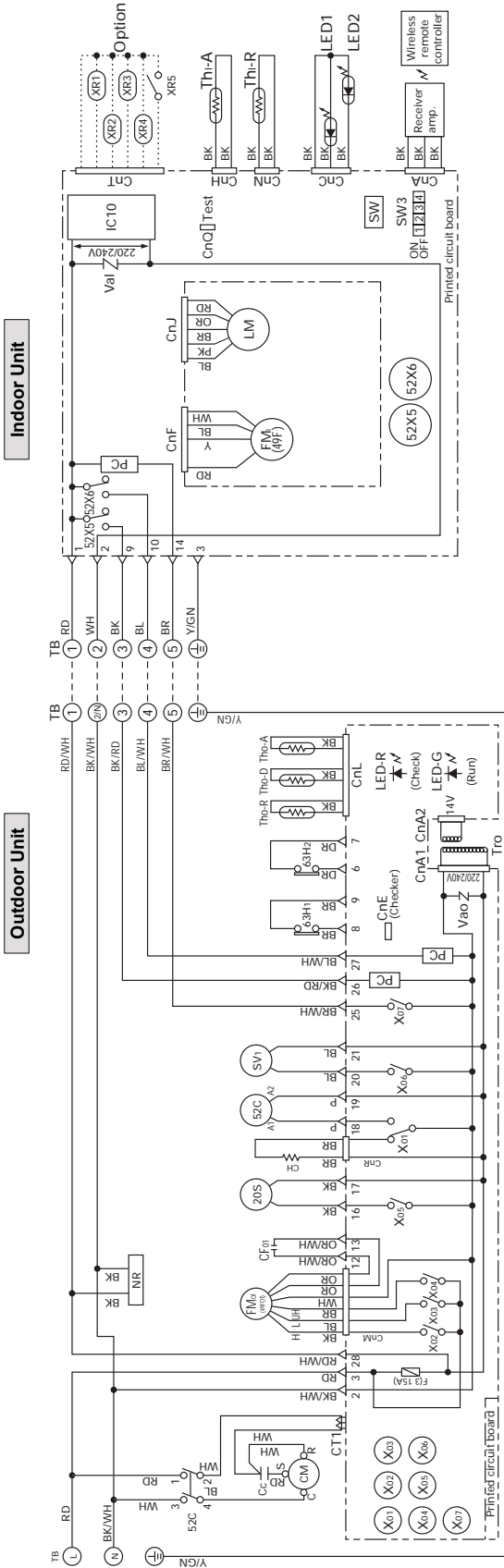

Meaning of marks

Mark	Parts name	Mark	Parts name
CC	Capacitor for CM	Th-R	Thermistor
CFo	Capacitor for FMo	Tho-A	Thermistor
CH	Crankcase heater	Tho-D	Thermistor
CM	Compressor motor	Tho-R	Thermistor
CnA ~ W	Connector (□mark)	Tro	Transformer
CT1	Current sensor	Val	Valvistor
F	Fuse	Vao	4-way valve solenoid
FMi	Fan motor (Indoor unit)	20S	Internal thermostat for FMi
FMo	Fan motor (Outdoor unit)	49F1	Internal thermostat for FMo
LED1	Indication lamp (Green - Run)	49Fo	Magnetic contactor for CM
LED2	Indication lamp (Yellow - Timer/Check)	52C	Auxiliary relay
LM	Louver motor	52X5, 6	Auxiliary relay
NR	Surge Suppressor	X01~07	High pressure switch (for Protection)
PC	Photo coupler	63H1	High pressure switch (for control)
SV1	Solenoid coil (for control)	63Hz	Terminal (F)
SW	Switch (ON/OFF)	LED-G	Indication lamp (Green)
SW3	Changeover switch	LED-R	Indication lamp (Red)
TB	Terminal block (□mark)		
Thi-A	Thermistor		

Color mark

Mark	Color	Mark	Color
BK	Black	BK/RD	Black/Red
BL	Blue	BK/WH	Black/White
BR	Brown	BL/WH	Blue/White
GR	Gray	BR/WH	Brown/White
OR	Orange	OR/WH	Orange/White
PK	Pink	RD/WH	Red/White
RD	Red	Y/GN	Yellow/Green
WH	White		
Y	Yellow		

Model FDKNP308HEN-S

Power source
1 Phase 220/240V 50Hz

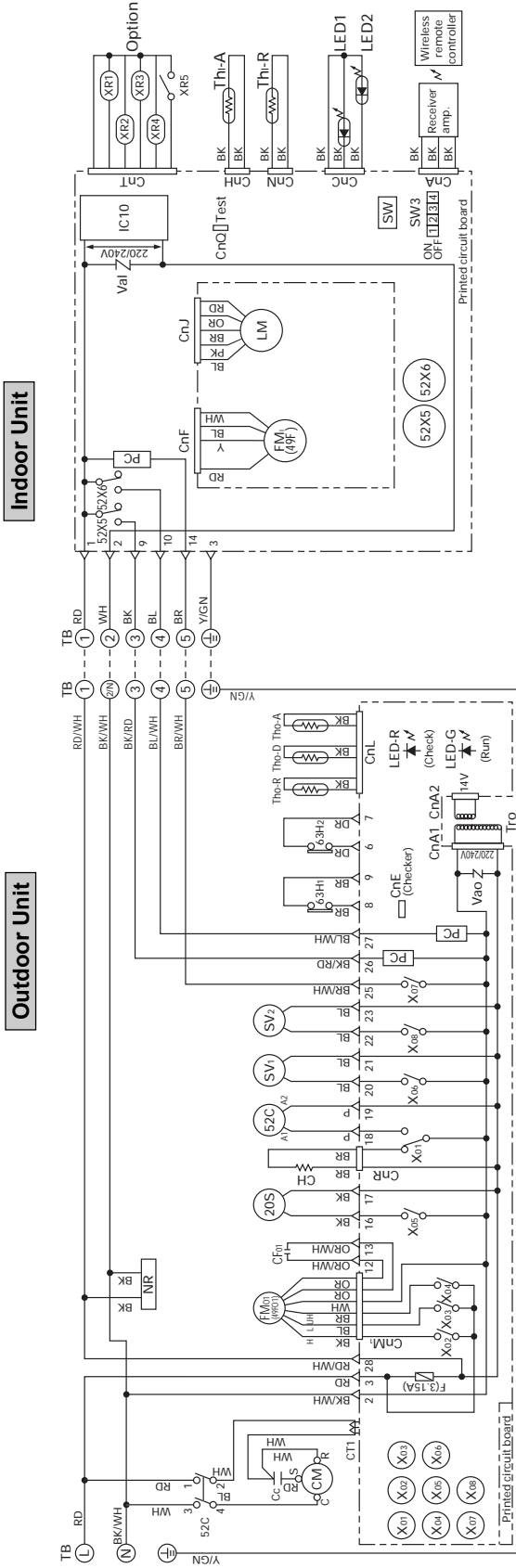

Color mark

Mark	Color	Mark	Color
BK	Black	BK/RD	Black/Red
BL	Blue	BK/WH	Black/White
BR	Brown	BL/WH	Blue/White
GR	Gray	BR/WH	Brown/White
OR	Orange	OR/WH	Orange/White
PK	Pink	RD/WH	Red/White
RD	Red	Y/GN	Yellow/Green
WH	White		
Y	Yellow		

Meaning of marks

Mark	Parts name	Mark	Parts name
CC	Capacitor for CM	Thi-R	Thermistor
CfO	Capacitor for FMo	Tho-A	Thermistor
CH	Crankcase heater	Tho-D	Thermistor
CM	Compressor motor	Tho-R	Thermistor
CnA ~ W	Connector (□mark)	Tro	Transformer
CT1	Current sensor	Val	Valvistor
F	Fuse	Vao	4-way valve solenoid
FmI	Fan motor (Indoor unit)	20S	Internal thermostat for FMi
FmO	Fan motor (Outdoor unit)	49F1	Internal thermostat for FMo
LED1	Indication lamp (Green - Run)	49Fo	Magnetic contactor for CM
LED2	Indication lamp (Yellow - Timer/Check)	52C	Auxiliary relay
LM	Louver motor	52X5, 6	Auxiliary relay
NR	Surge suppressor	X01-8	High pressure switch (for protection)
PC	Photo coupler	63H1	High pressure switch (for control)
SV1,2	Solenoid coil (for control)	63Hz	Terminal (F)
SW	Switch (ON/OFF)	LED-G	Indication lamp (Green)
SW3	Changeover switch	LED-R	Indication lamp (Red)
TB	Terminal block (○mark)		
Thi-A	Thermistor		

Model FDKNP308HES-S

Power source
3 Phase 380/415V 50Hz

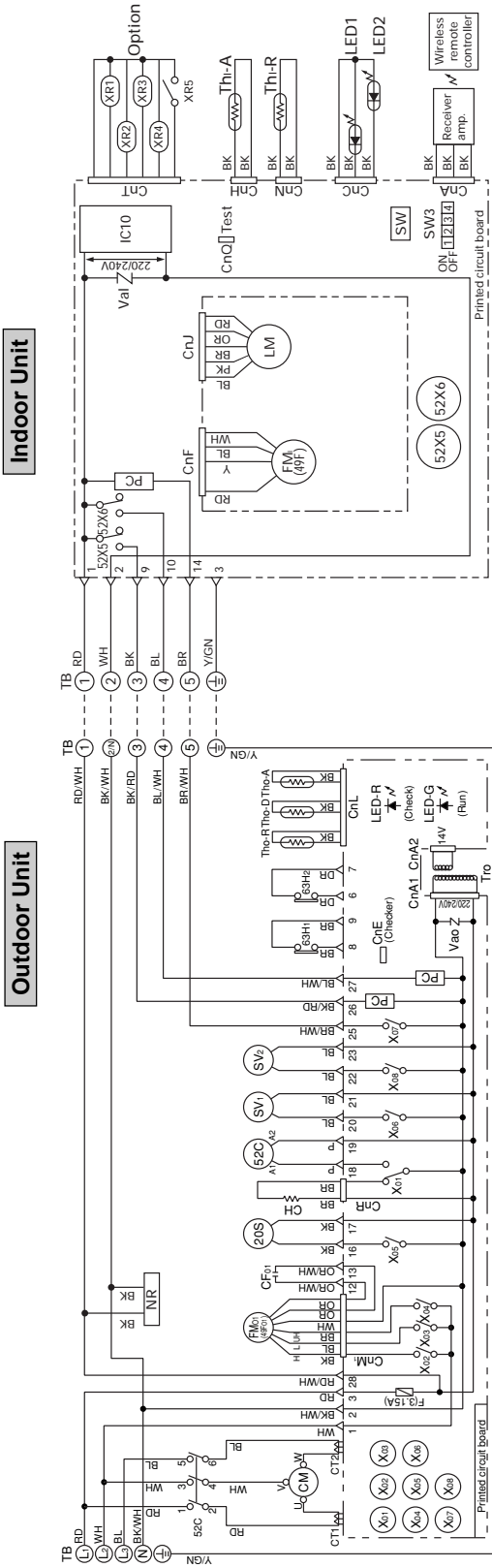

Color mark

Mark	Color	Mark	Color
BK	Black	BK/RD	Black/Red
BL	Blue	BK/WH	Black/White
BR	Brown	BL/WH	Blue/White
GR	Gray	BR/WH	Brown/White
OR	Orange	OR/WH	Orange/White
P	Pink	RD/WH	Red/White
RD	Red	Y/GN	Yellow/Green
WH	White		

Meaning of marks

Mark	Parts name	Mark	Parts name
CF1	Capacitor for FM1	Th-R	Thermistor
CF01	Capacitor for FM0	Th-A	Thermistor
CH	Crankcase heater	Th-D	Thermistor
CM	Compressor motor	Th-R	Thermistor
CnA ~ Z	Connector (□mark)	Tro	Transformer (Outdoor unit)
CT1,2	Current sensor	Val	Valve solenoid
F	Fuse	Vao	4-way valve solenoid
FM1	Fan motor (Indoor unit)	20S	Internal thermostat for FM1
FM01	Fan motor (Outdoor unit)	49F1	Internal thermostat for FM0
LED1	Indication lamp (Green-Run)	49F01	Magnetic contactor for CM
LED2	Indication lamp (Yellow-Timer/Check)	52C	Auxiliary relay
LM	Louver motor	52X5, 6	Auxiliary relay
NR	Surge suppressor	X01-08	High pressure switch (for protection)
PC	Photo coupler	63H1	High pressure switch (for control)
SV1,2	Solenoid coil (for control)	63H2	High pressure switch (for control)
SW	Switch (ON/OFF)	▽	Terminal (F)
SW3	Changeover switch	■	Indication lamp (Green)
TB	Terminal block (○mark)	LED-G	Indication lamp (Red)
Th-A	Thermistor	LED-R	Indication lamp (Red)

12.4 OUTLINE OF OPERATION CONTROL BY MICROCOMPUTER

Same as the cooling/heating equipment for FDT (N) heat pump type. Refer to page 317.

12.5 APPLICATION DATA

SAFETY PRECAUTIONS

- Please read these “Safety Precautions” first then accurately execute the installation work.
 - Though the precautionary points indicated herein are divided under two headings, **⚠WARNING** and **⚠CAUTION**, those points which are related to the strong possibility of an installation done in error resulting in death or serious injury are listed in the **⚠WARNING** section. However, there is also a possibility of serious consequences in relationship to the points listed in the **⚠CAUTION** section as well.
- In either case, important safety related information is indicated, so by all means, properly observe all that is mentioned.
- After completing the installation, along with confirming that no abnormalities were seen from the operation tests, please explain operating methods as well as maintenance methods to the user (customer) of this equipment, based on the owner’s manual. Moreover, ask the customer to keep this sheet together with the owner’s manual.

⚠WARNING

- This system should be applied to places of office, restaurant, residence and the like. Application to inferior environment such as engineering shop could cause equipment malfunction.
- Please entrust installation to either the company which sold you the equipment or to a professional contractor. Defects from improper installations can be the cause of water leakage, electric shocks and fires.
- Execute the installation accurately, based on following the installation manual. Again, improper installations can result in water leakage, electric shocks and fires.
- When a large air-conditioning system is installed to a small room, it is necessary to have a prior planned countermeasure for the rare case of a refrigerant leakage, to prevent the exceeding of threshold concentration. In regards to preparing this countermeasure, consult with the company from which you purchased the equipment, and make the installation accordingly. In the rare event that a refrigerant leakage and exceeding of threshold concentration does occur, there is the danger of a resultant oxygen deficiency accident.
- For installation, confirm that the installation site can sufficiently support heavy weight. When strength is insufficient, injury can result from a falling of the unit.
- Execute the prescribed installation construction to prepare for earthquakes and the strong winds of typhoons and hurricanes, etc. Improper installations can result in accidents due to a violent falling over of the unit.
- For electrical work, please see that a licensed electrician executes the work while following the safety standards related to electrical equipment, and local regulations as well as the installation instructions, and that only exclusive use circuits are used.
Insufficient power source circuit capacity and defective installment execution can be the cause of electric shocks and fires.
- Accurately connect wiring using the proper cable, and insure that the external force of the cable is not conducted to the terminal connection part, through properly securing it. Improper connection or securing can result in heat generation or fire.
- Take care that wiring does not rise upward, and accurately install the lid/service panel. Its improper installation can also result in heat generation or fire.
- When setting up or moving the location of the air-conditioner, do not mix air etc. or anything other than the designated refrigerant (R22) within the refrigeration cycle.
Rupture and injury caused by abnormal high pressure can result from such mixing.
- Always use accessory parts and authorized parts for installation construction. Using parts not authorized by this company can result in water leakage, electric shock, fire and refrigerant leakage.

⚠CAUTION

- Execute proper grounding. Do not connect the ground wire to a gas pipe, water pipe, lightning rod or a telephone ground wire. Improper placement of ground wires can result in electric shock.
- The installation of an earth leakage breaker is necessary depending on the established location of the unit. Not installing an earth leakage breaker may result in electric shock.
- Do not install the unit where there is a concern about leakage of combustible gas.
The rare event of leaked gas collecting around the unit could result in an outbreak of fire.
- For the drain pipe, follow the installation manual to insure that it allows proper drainage and thermally insulate it to prevent condensation. Inadequate plumbing can result in water leakage and water damage to interior items.

12.5.1 Installation of indoor unit

NOTICE

All Wiring of this installation must comply with NATIONAL, STATE AND LOCAL REGULATIONS. These instructions do not cover all variations for every kind of installation circumstance. Should further information be desired or should particular problems occur, the matter should be referred to Mitsubishi Heavy Industries, Ltd. through your local distributor.

WARNING

BE SURE TO READ THESE INSTRUCTIONS CAREFULLY BEFORE BEGINNING INSTALLATION. FAILURE TO FOLLOW THESE INSTRUCTIONS COULD CAUSE SERIOUS INJURY OR DEATH, EQUIPMENT MALFUNCTION AND/OR PROPERTY DAMAGE.

(1) Selection of installation location

- (a) Select the installation location that meets the following conditions and obtain the customer's consent.
- 1) Location where cold and warm air spread all over the room
 - 2) Location where piping and wiring to the outdoors can easily be laid down.
 - 3) Location where the drain can be discharged completely.
 - 4) Location where the wall to mount the unit is rigid.
 - 5) Location where there is no wind obstruction to the return air and supply air grills.
 - 6) Location not exposed to direct sunshine.
 - 7) Avoid the location exposed to oil splash or vapor.
 - 8) Avoid the location near to the machine emitting high-frequency radio wave.
 - 9) Avoid the location where the receiver of remote control is subject to strong illumination.
 - 10) Select the location where the unit can securely be operated by the wireless remote controller referring to the Article "Effective distance of wireless remote controller" indicated at the backside.
 - 11) Secure the space for inspection and maintenance work.

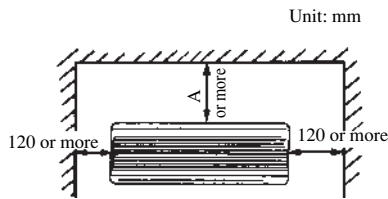

Dimension	FDKN208 type	FDKN258 · 308 type
A	65	90

(2) Cautions for use of wireless remote controller

- (a) Operating distance of wireless remote controller

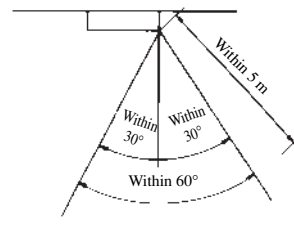
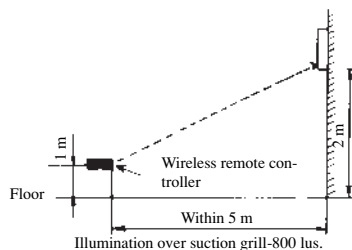

Relation between illumination at receiver unit and operating distance

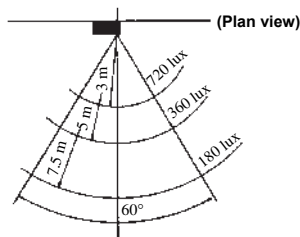

Caution item for close installation of multiple units

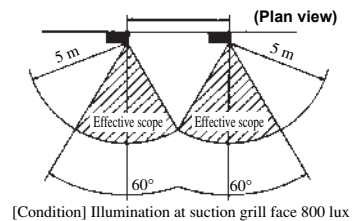

- (b) Cautions for operation

- 1) Orient the remote control switch properly toward the receiver of the unit.
- 2) Operating distance is as shown above but it may vary largely depending on the conditions.
- 3) Effective distance may be shortened and the receiving may be disturbed when the receiver is under the condition of direct exposure to sunlight or other strong light like electric bulb, dust is accumulated on it and it is shielded with a curtain, etc.

(3) Carry-in and installation of unit

(a) Carry-in

- 1) When carrying in the unit, carry it in as packed to the installation site as near as possible.
- 2) If you are compelled to carry in the unit unpacked, cover it with a nylon sling so that it is not damaged.
Note) Do not carry the unit by holding it at the supply air louver.
- 3) When laying the unit on the ground after unpacking, place it with its front side up without fail.

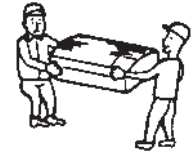

(b) Attaching of mounting plate

- 1) The indoor unit weighs approx, 11 kg. Therefore, check whether the portion to install the unit can bear the weight of unit. If it seems to be danger, reinforce the portion by a plate or a beam before installing the unit. It is not allowed to install the unit directly on the wall. Whenever you install the unit, use the attached mounting plate.
- Find structural members (Intermediate pillar, etc.) suitable for mounting the unit, then install the unit firmly while checking levelness.
 - Adjust the level of mounting plate under the condition that four screws are tightened temporarily.

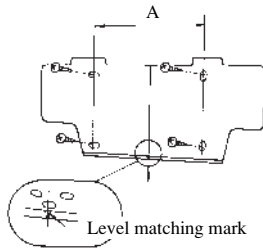

Model	FDKN208 · 258 type	FDKN308 type
Dimension		
A	450	690



- Turn the mounting plate around the reference hole to adjust the levelness.

WARNING

- Install the unit where it can bear the weight with sufficient strength margin. In the case of insufficient strength or insufficient installation work, the unit may fall and cause injury.

(c) Procedure for making hole on the wall

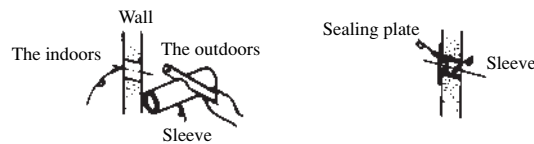

- Make a downgrade (5°) from the indoors toward the outdoors.

(d) Forming of piping and drain hose

1) Rear take out case

- Forming of piping
- Tape winding

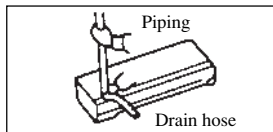

- Hold the root portion of piping, change the direction then expand and make forming.

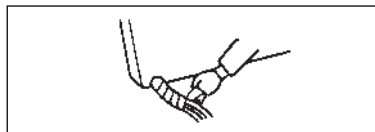

- Wind the tape on the portion which passes through the hole on the wall.
- Always make taping on the wiring which crosses with the piping, if any.

After forming of piping and before tape winding, confirm that the connecting wire is securely fixed to the terminal table.

The piping can be taken out from the rear, left, left rear, right and down.

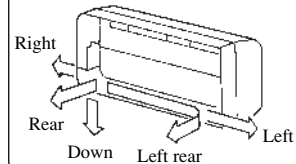

2) Cautions for left take-out and rear take-out case

a) Looking down

For left running horizontal piping For left rear take-out piping	For right running horizontal piping For right rear take-out piping
For left running horizontal piping	For right running horizontal piping

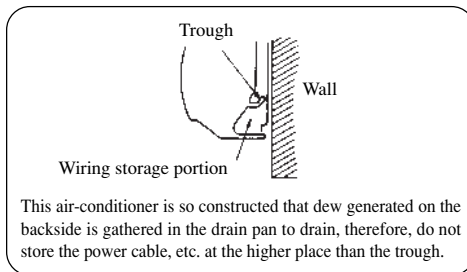

b) Procedure for changing drain hose

1. Remove the drain hose. 	2. Remove the drain cap. 	3. Insert the drain cap. 	4. Connect the drain hose.
-------------------------------	------------------------------	------------------------------	--------------------------------

- Loosen spring type clamp to remove.

- Remove by hand or pliers.

- Insert the drain cap which was removed in procedure 2 securely using a hexagonal wrench, etc.
Note: When it is not inserted securely, water leakage may occur.

- Loosen the spring type clamp to insert the drain hose securely.
Note: When it is not inserted securely, water leakage may occur.

(e) Installation of unit

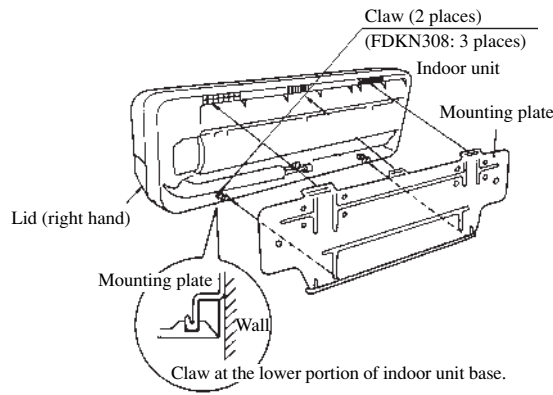

- To remove the unit from the mounting plate, remove the right and left lids then remove the claw at the lower portion of base.

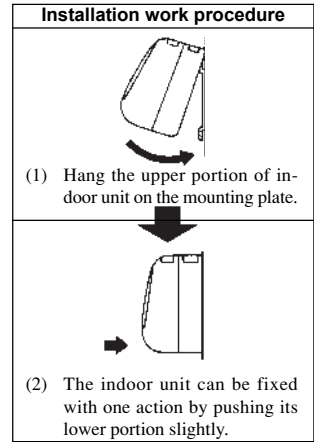

(4) Refrigerant piping

- (a) Comply the following table for the tightening torque of the flared nut and flange bolt.

Flared nut tightening torque	
φ6.35:	16 to 20 (N-m), (1.6 to 2.0 kg-m)
φ9.52:	40 to 50 (N-m), (4 to 5 kg-m)
φ15.88:	90 to 120 (N-m), (9 to 12 kg-m)

Wrap the gaseous refrigerant piping and liquid refrigerant piping with thermal insulator perfectly.

- (b) In the case of liquid refrigerant piping, if it is not insulated, dew condensation and water leakage may occur.
- (c) When removing the flared nut at the piping end of unit, always use 2 of spanners, and when connecting the pipe tighten it firmly using 2 of spanners.
- (d) When connecting the flared nut, apply refrigerating machine oil on the back surface of flare and screw-in the nut for the first 3 to 4 turns by hand.
- (e) Use the pipe made of the following material. It is very convenient to use the separately sold piping kit.
Material: Phosphor deoxidized seamless copper tube (C1220T, JIS H3300)
- (f) Cover the connection part with indoor unit insulation material and insulate the notched part with attached insulation and then wrap it up with tape.

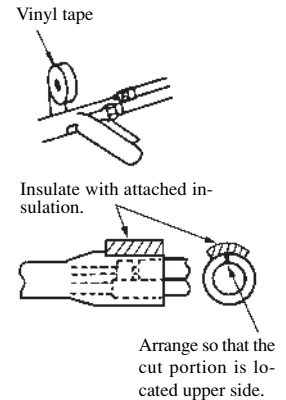

(5) Drain piping

- (a) Lay the drain piping with downgrade to facilitate flow of drain, and do not make a trap or chevron-shaped bend. (The drain piping can be taken out from the unit to the left, right, rear and down direction.)
Wrap the thermal insulator on the hard vinyl chloride pipe (VP-16) laid in the room.
- (b) Pour water into the drain pan below the heat exchanger to check that water is drained outdoors.

CAUTION
The drainage work must be performed surely and the drainage must be checked. If drainage is not perfect, it causes water leakage.

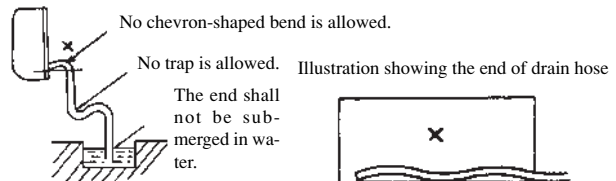

Hard vinyl chloride pipe (general-purpose pipe VP-16) can be connected.

(6) Fixing of wiring

- (a) Remove the front panel.
- (b) Connect the wire from the indoor and outdoor units to the terminal table of control box.
- (c) Attach the front panel.

- Notes (1) Refer to the illustration below for the removal and attaching of the front panel.
(2) Before connecting the wiring to the terminal table, confirm the terminal number.

(d) Removal order of the panel

- 1) Open the return air grill. (Pull both lower ends of the return air grill, raise the grill until the reaction is felt after disengaging the latch. The return air grill will stop at approx. 60° open position.)
- 2) Remove the air filter.
- 3) Remove 2 fixing screws for model 258 and 3 fixing screws for model 308.
- 4) Close the return air grill. (Hold both lower ends of the return air grill, lower the grill slowly downward, push it slightly to engage the latch and again push the center portion slightly.)
- 5) Remove the fixing screw of front panel. (2 places for 208, 3 places for 258, and 4 places for 308.)
- 6) Lift the lower portion of front panel this side and remove it while pushing the upper portion up.

(e) Attaching order of the panel

- 1) Lay the front panel on the main body.
- 2) Push the "O" portion shown in the illustration from front side.
- 3) Tighten the fixing screw of front panel.
- 4) Open the return air grill to tighten the cap screw. (258, 308 only)
- 5) Set the air filter.
- 6) Close the return air grill.

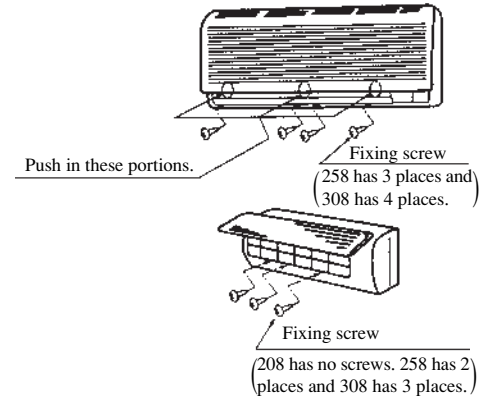

By switching the dip switch (SW3-3) on the indoor unit printed circuit board ("Specify the following switch number."), the operation mode can be changed to the quiet mode (mild mode). Confirm at installation and change if necessary.

12.5.2 Installation of outdoor unit

Same as the cooling/heating equipment for FDT (N) heat pump type.
Refer to page 338.

12.6 MAINTENANCE DATA

Same as the cooling/heating equipment for FDT (N) heat pump type.
Refer to page 348.