



# Installation, operating and maintenance



**BALTIC™** Rooftop units air cooled

**20 - 85 kW**





# BALTIC™

## Installation, operating and maintenance

---

Ref : BALTIC-IOM-0412-E

INSTALLATION MANUAL	1
SERVICE MANUAL	28
CONTROL MANUAL	74
CERTIFICATES	84

All the technical and technological information contained in this manual, including any drawing and technical descriptions provided by us, remain the property of Lennox and must not be utilised (except in operation of this product), reproduced, issued to or made available to third parties without the prior written agreement of Lennox.



# INSTALLATION MANUAL

Ref : BALTIC\_Installation-IOM-0412-E

<b>INSTALLATION MANUAL</b>	
Safety codes & regulations	3
<b>TRANSPORT &amp; HANDLING</b>	
Mandatory handling devices	5
<b>LIFTING THE UNITS</b>	
Machine dimensions and weights	6
Minimum clearance around the unit installation	7
Fork lifting the unit	7
Removing the forklift protection located under the machine	8
Lifting the unit with a crane	9
Lifting the roof curbs	10
<b>DELIVERY CHECKS</b>	
Rating plate	12
Storage	12
Maintenance key	12
Condensate drains	13
Preliminary checks	13
Installation requirements	13
Connections	13
<b>INSTALLATION ON A ROOF MOUNTING FRAME</b>	
Roof opening dimensions	14
Sealing checks	14
Leveling adjustable roofcurbs	14
Positioning the rooftop on adjustable roofcurbs	15
<b>NON ADJUSTABLE NON ASSEMBLED ROOFCURB INSTALLATION</b>	
Frame parts packing	16
Installation	17
Assembly	17
Securing the frame	17
Sealing checks	18
<b>CURBING AND FLASHING</b>	18
<b>HEAT RECOVERY GENERAL DESCRIPTION</b>	19
<b>PLATE HEAT RECOVERY CONFIGURATIONS</b>	20
<b>PLATE HEAT RECOVERY INSTALLATION</b>	21
<b>THERMODYNAMIC HEAT RECOVERY CONFIGURATIONS</b>	23
<b>THERMODYNAMIC HEAT RECOVERY - SERVICE MANUAL</b>	24
<b>THERMODYNAMIC HEAT RECOVERY - CONTROL MANUAL</b>	26

The present manual applies to the following rooftop versions

Item	Net cooling capacity (kW - Eurovent conditions)	Heating capacity (kW - Eurovent conditions) HeatPump	Heating capacity (KW) GAS
<b>COOLING ONLY</b>			
BAC 024 SNM 3M	23,4	-	-
BAC 030 SNM 3M	29,2	-	-
BAC 038 SNM 3M	37,1	-	-
BAC 042 SNM 3M	39,4	-	-
BAC 045 DNM 3M	43,9	-	-
BAC 052 DNM 3M	49,8	-	-
BAC 057 DNM 3M	55,2	-	-
BAC 065 DNM 3M	62,6	-	-
BAC 075 DNM 3M	74,1	-	-
BAC 085 DNM 3M	80,7	-	-
<b>HEAT PUMP</b>			
BAH 024 SNM 3M	23,4	20,7	-
BAH 030 SNM 3M	29,2	26,2	-
BAH 038 SNM 3M	37,1	34,8	-
BAH 042 SNM 3M	39,4	38,0	-
BAH 045 DNM 3M	43,9	40,8	-
BAH 052 DNM 3M	49,8	46,2	-
BAH 057 DNM 3M	55,2	54,4	-
BAH 065 DNM 3M	62,6	62,2	-
BAH 075 DNM 3M	74,1	73,5	-
BAH 085 DNM 3M	80,7	80,1	-
<b>GAS ONLY - STD HEAT</b>			
BAG 024 SSM 3M	23,3	-	20
BAG 030 SSM 3M	28,9	-	20
BAG 038 SSM 3M	36,8	-	20
BAG 042 SSM 3M	39,1	-	20
BAG 045 DSM 3M	43,7	-	33
BAG 052 DSM 3M	49,5	-	33
BAG 057 DSM 3M	54,7	-	33
BAG 065 DSM 3M	61,9	-	33
BAG 075 DSM 3M	73,4	-	60
BAG 085 DSM 3M	79,8	-	60
<b>GAS ONLY - HIGH HEAT</b>			
BAG 024 SHM 3M	23,3	-	46
BAG 030 SHM 3M	28,9	-	46
BAG 038 SHM 3M	36,8	-	46
BAG 042 SHM 3M	39,1	-	46
BAG 045 DHM 3M	43,7	-	60
BAG 052 DHM 3M	49,5	-	60
BAG 057 DHM 3M	54,7	-	60
BAG 065 DHM 3M	61,9	-	60
BAG 075 DHM 3M	73,4	-	120
BAG 085 DHM 3M	79,8	-	120
<b>DUAL FUEL - STD</b>			
BAM 024 SSM 3M	23,3	20,8	20
BAM 030 SSM 3M	28,9	26,5	20
BAM 038 SSM 3M	36,8	35,1	20
BAM 042 SSM 3M	39,1	38,4	20
BAM 045 DSM 3M	43,7	41,0	33
BAM 052 DSM 3M	49,5	46,6	33
BAM 057 DSM 3M	54,7	54,9	33
BAM 065 DSM 3M	61,9	62,8	33
BAM 075 DSM 3M	73,4	74,2	60
BAM 085 DSM 3M	79,8	81,0	60
<b>DUAL FUEL - HIGH</b>			
BAM 024 SHM 3M	23,3	20,8	46
BAM 030 SHM 3M	28,9	26,5	46
BAM 038 SHM 3M	36,8	35,1	46
BAM 042 SHM 3M	39,1	38,4	46
BAM 045 DHM 3M	43,7	41,0	60
BAM 052 DHM 3M	49,5	46,6	60
BAM 057 DHM 3M	54,7	54,9	60
BAM 065 DHM 3M	61,9	62,8	60
BAM 075 DHM 3M	73,4	74,2	120
BAM 085 DHM 3M	79,8	81,0	120

## Safety codes & regulations

THE UNIT MUST BE INSTALLED IN ACCORDANCE WITH LOCAL SAFETY CODES AND REGULATIONS AND CAN ONLY BE USED IN WELL VENTILLATED AREA.

PLEASE READ CAREFULLY THE MANUFACTURER'S INSTRUCTIONS BEFORE STARTING THIS UNIT.

INSPECTIONS AND REQUALIFICATION ACCORDING PRESSURE EQUIPMENT DIRECTIVE MUST FOLLOW THE LOCAL REGULATIONS WHERE THE UNIT IS INSTALLED.

### Important note for unit fitted with gas burner:

THIS MANUAL IS ONLY VALID FOR UNITS DISPLAYING THE FOLLOWING CODES:

GB

IR

GR

DA

NO

FI

IS

In case these symbols are not displayed on the unit, please refer to the technical documentation which will eventually detail any modifications required to the installation of the unit in a particular country.

- If machine is including gas burner, minimum clearance around the unit must be at least 8 m to allow a proper gas flue dilution. If not possible, the fresh air intake must be ducted at least 8 m away from the gas burner exhaust.
- The gas burner air intake and exhaust chimney must not be modified or ducted.
- Before commissioning this type of unit, it's mandatory to ensure that the gas distribution system is compatible with the adjustments and settings of the unit.
- Gas module can only be used for outdoor installations.
- Any work on gas module must be carried out by qualified engineer.

All the technical and technological information contained in this manual, including any drawing and technical descriptions provided by us, remain the property of LENNOX and must not be utilised (except in operation of this product), reproduced, issued to or made available to third parties without the prior written agreement of LENNOX. The technical information and specifications contained in this manual are for reference only. The manufacturer reserves the right to modify these without warning and without obligation to modify equipment already sold.

### All units are compliant with the PED directive 97-23/CE

#### The following note must be followed carefully

##### All work on the unit must be carried out by a qualified and authorised employee.

Non-compliance with the following instructions may result in injury or serious accidents.

##### **Work on the unit:**

- The unit shall be isolated from the electrical supply by disconnection and locking using the main isolating switch.
- Workers shall wear the appropriate personal protective equipment (helmet, gloves, glasses, etc.).

##### **Work on the electrical system:**

- Work on electric components shall be performed with the power off (see below) by employees having valid electrical qualification and authorisation.

##### **Work on the refrigerating circuit(s):**

- Monitoring of the pressures, draining and filling of the system under pressure shall be carried out using connections provided for this purpose and suitable equipment.
- To prevent the risk of explosion due to spraying of coolant and oil, the relevant circuit shall be drained and at zero pressure before any disassembly or unbrazing of the refrigerating parts takes place.
- There is a residual risk of pressure build-up by degassing the oil or by heating the exchangers after the circuit has been drained. Zero pressure shall be maintained by venting the drain connection to the atmosphere on the low pressure side.

- The brazing shall be carried out by a qualified brazier. The brazing shall comply with standard NF EN1044 (minimum 30% silver).

## EMC DIRECTIVE COMPLIANCE

### WARNING:

This equipment is an "A class" according CEM Directive. In an industrial environment, this device can create radio electrical noise. In this case, the owner can be asked to take appropriated actions.

This applies to all machine installed with nominal amps below <75A:

- The short-circuit rate  $R_{sce}=33$  is defined in the EN61000-3-12 standard relative to the harmonics readings on the supply network. The appliances compliant with the harmonic current limits equivalent to  $R_{sce}=33$  can be connected in whatever connection point of the main supply system.
- The maximal allowable impedance of the main supply system  $Z_{max}=0.051W$  is defined by EN 61000-3-11 standard relative to the voltage variation, fluctuation and flicker readings. The connection to the supply is a conditional connection submitted to the preliminary agreement of the power supply local provider.

### Replacing components:

- In order to maintain CE marking compliance, replacement of components shall be carried out using spare parts, or using parts approved by LENNOX.
- Only the coolant shown on the manufacturer's nameplate shall be used, to the exclusion of all other products (mix of coolants, hydrocarbons, etc.).

### CAUTION:

**In the event of fire, refrigerating circuits can cause an explosion and spray coolant gas and oil.**

### Transport – Handling- Access:

- Never lift the unit without forklift protections
- An approach ramp must be installed if the unit's installation requirements tell that it's necessary to reach the main switch, the electrical cabinet, the compressor and the ventilation compartment. This recommendation is valid for all type of installations.
- It is strictly forbidden to walk or store equipment or material on top of the rooftop unit

### Rooftop installation in heavy wind locations

- The roofcurbs (vertical & horizontal) and rooftops installations are designed to withstand winds up to 80 km/h. Above this limit, it's recommended to take appropriate actions to secure the installation.
- Ensure the fresh air inlet does not face prevailing wind direction.

### Elbow or section changes in ductworks next to the rooftop

- Whatever the supply configuration is, respect a minimal duct's length of 2 m before any elbow or any duct's section change.
- Directional vanes must be fitted inside any elbow fitted in return or supply ductwork closer than 5 meter to the machine connection flanges.

### Filters:

- Do the filters fire classification's choice according to local regulations.

### Fan compartment:

- Stop the power before accessing the fan compartment.

### Gas:

- Any work on gas module must be carried out by qualified personnel
- A unit with gas module must be installed in accordance with local safety codes and regulations and can only be used for outdoor installation.

*The technical information and specifications contained in this manual are for reference only. The manufacturer reserves the right to modify these without warning and without obligation to modify equipment already sold.*



Mandatory handling devices

MANDATORY HANDLING DEVICES

Handling slings to guide the unit toward the roof curb

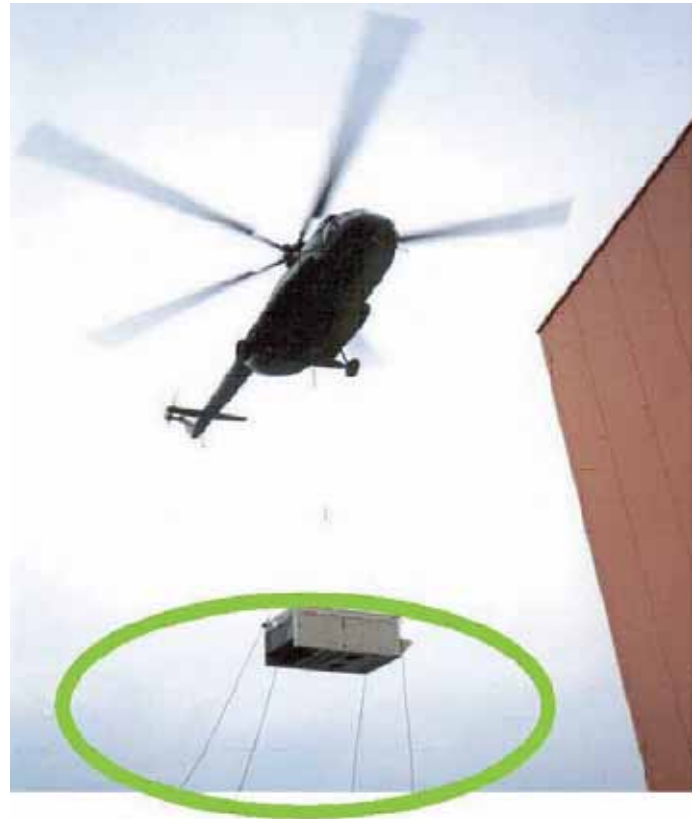

Vacuum lifting beam to position the unit



## Machine dimensions and weights

Machine	Length	Width	Height	Width with hood	Transport length	Transport Width	Transport Height
Cbox	2283+/-15	2250+/-15	1240+/-15	2683+/-20	2310	2309	1240
Dbox	2783+/-15	2250+/-15	1240+/-15	2683+/-20	2810	2309	1240
Ebox	3663+/-15	2250+/-15	1240+/-15	2683+/-20	3690	2309	1240

Unit		24	30	38	42	45	52	57	65	75	85
Base weight (kg)	Cooling	696	711	726	726	937	952	967	982	1150	1150
	HeatPump	701	716	731	731	947	962	977	992	1165	1165
	Gas S	739	754	769	769	970	985	1000	1015	1225	1225
	Gas H	758	773	788	788	992	1007	1022	1037	1285	1285
	Dual S	744	759	774	774	980	995	1010	1025	1235	1235
	Dual H	763	778	793	793	1002	1017	1032	1047	1295	1295
Option weight (kg)	Horizontal return & supply	-12,1	-12,1	-12,1	-12,1	-18,9	-18,9	-18,9	-18,9	-23,2	-23,2
	Horizontal return & vertical supply	-7	-7	-7	-7	-10,3	-10,3	-10,3	-10,3	-13,6	-13,6
	Vertical return & horizontal supply	-5,1	-5,1	-5,1	-5,1	-8,6	-8,6	-8,6	-8,6	-9,6	-9,6
	Gravity exhaust damper	0,9	0,9	0,9	0,9	1,8	1,8	1,8	1,8	2,5	2,5
	Power exhaust fan	11,2	11,2	11,2	11,2	20,8	20,8	20,8	20,8	30,3	30,3
	F7 filter	22,8	22,8	22,8	22,8	30,9	30,9	30,9	30,9	39	39
	F4 filter	3	3	3	3	4,5	4,5	4,5	4,5	6	6
	Double skin	14	14	14	14	21,5	21,5	21,5	21,5	31,2	31,2
	Electrical heater S	20,8	20,8	20,8	20,8	26,7	26,7	26,7	26,7	26,7	26,7
	Electrical heater H	25,4	25,4	25,4	25,4	32,5	32,5	32,5	32,5	32,5	32,5
	Electrical preheater S	37,4	37,4	37,4	37,4	45	45	45	45	62,3	62,3
	Electrical preheater H	49,6	49,6	49,6	49,6	67,5	67,5	67,5	67,5	92,9	92,9
	Hot water coil	36,2	36,2	36,2	36,2	54,9	54,9	54,9	54,9	86,4	86,4
Energy recovery coil	20,9	20,9	20,9	20,9	28,4	28,4	28,4	28,4	35,9	35,9	
Accessorie weight (kg)	Non ajustable roofcurb	65	65	65	65	70	70	70	70	87	87
	Ajustable roofcurb	139	139	139	139	156	156	156	156	195	195
	Extraction curb vertical	272	272	272	272	295	295	295	295	440	440
	Extraction curb horizontal	218	218	218	218	241	241	241	241	358	358
	Multidirectional curb	174	174	174	174	209	209	209	209	239	239

### Minimum clearance around the unit installation

Figure below show the required clearances and service access around the unit.

**IMPORTANT note for unit clearances**

- Ensure the fresh air inlet does not face prevailing wind direction.
- If machine is including gas burner, minimum clearance around the unit must be at least 8 m to allow a proper gas flue dilution. If not possible, the fresh air intake must be ducted at least 8 m away from the gas burner exhaust.
- In case of extraction option, it is recommended to duct fresh air intake.

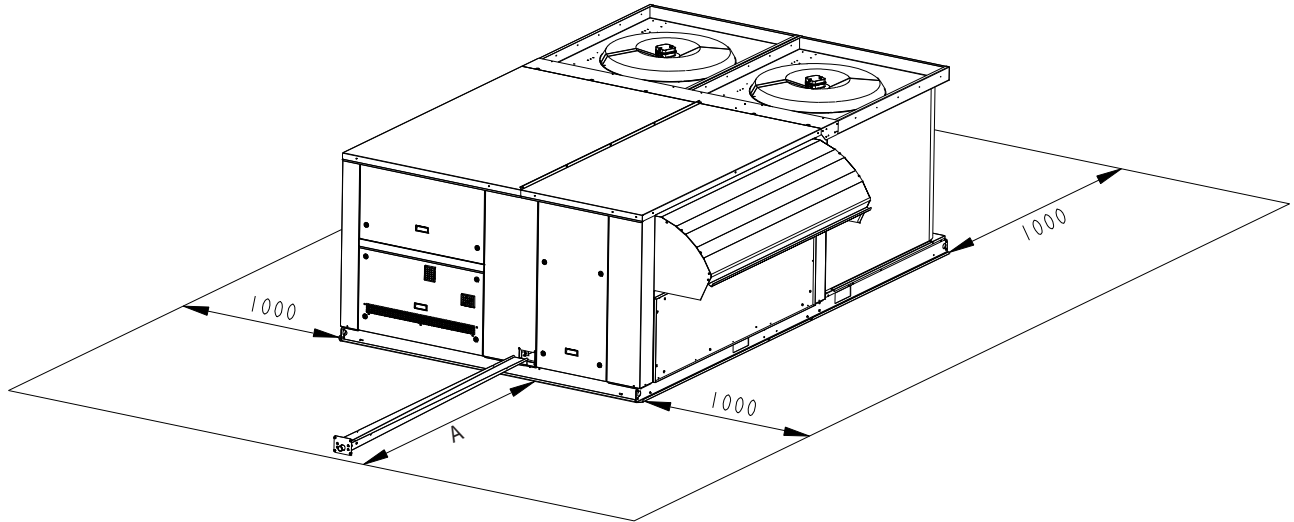

Drain pan clearance (A)	
C Box	1150 <sup>(1)</sup>
D Box	1650 <sup>(1)</sup>
E Box	2150 <sup>(1)</sup>

### Fork lifting the unit

Do not lift the unit by the side (coil end side or drain pan outlet side). This will damage the unit. Lift the unit on the long side using a forklift with dimensions according to the figure below. Do not remove the unit plastic cover while lifting.



### Removing the forklift protection located under the machine

Before installation, remove the forklift protection which is located under machine desk.

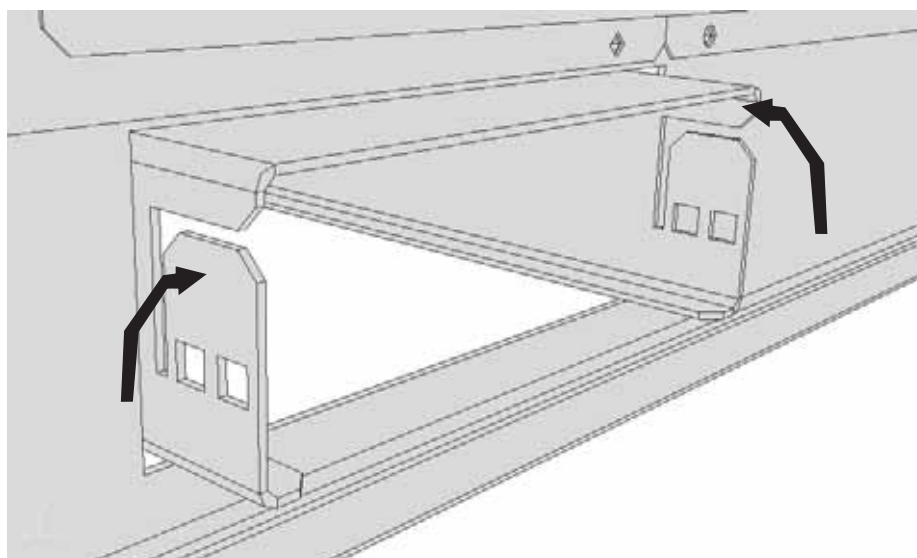

**IMPORTANT note about forklift protection removal**

Take care not to hurt anybody when removing the forklift rails .  
 Locate the machine on a safe area while removing the forklift rails from the machine.

## Lifting the unit with a crane

### Lifting lug dimensions

Use lifting shackles located on each angle of the unit. Maximum diameter of the ring shaft = 20 mm.

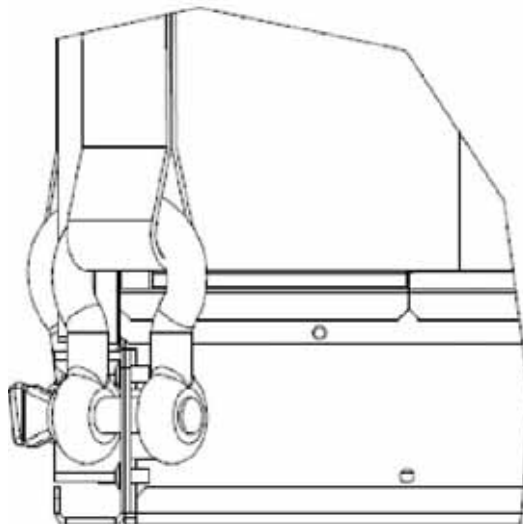

### Lifting belts length

The unit must be lifted using spacing beams to avoid the belts damages to the casing. Spacing beams must have a length equal to the machine width – i.e 2250 mm.

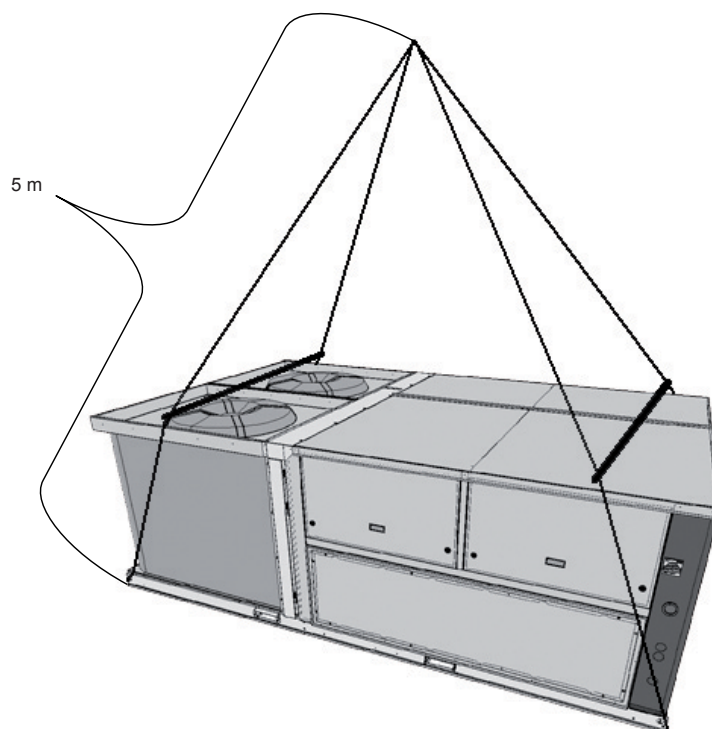

## Lifting the roof curbs

### Ducting connection details

The supply and return air ducts can be secured to the 30 mm flanges at the bottom of the roof curb. Any ducting weight above 100 kg must be fixed independently to other building frames.

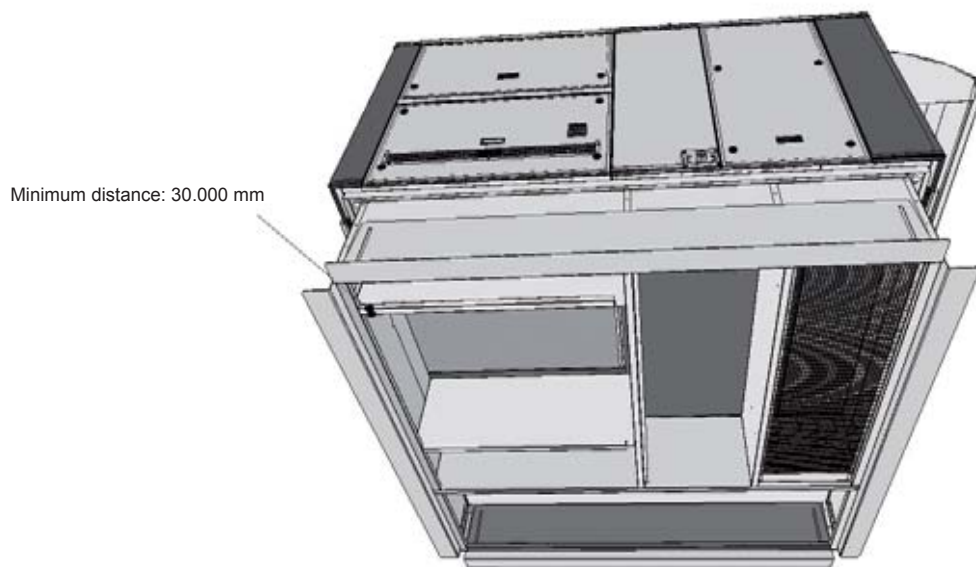

Non adjustable roofcurb

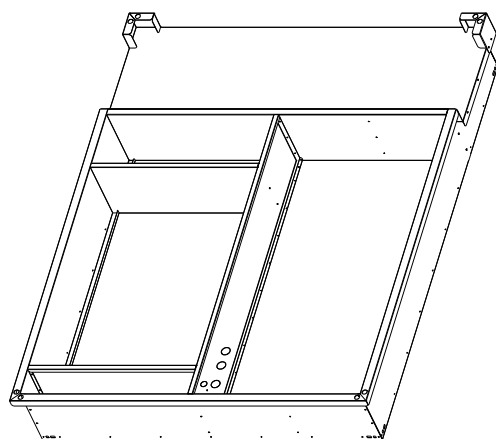

Adjustable roofcurb

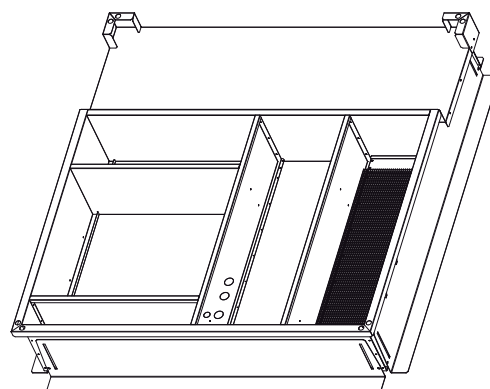

Exhaust roofcurb

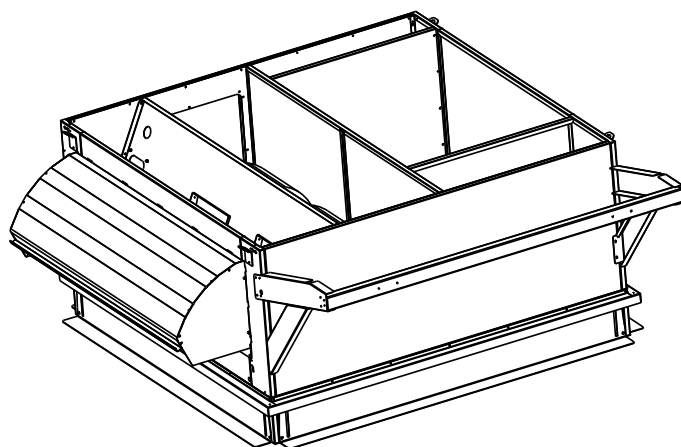

Multidirectionnal roofcurb

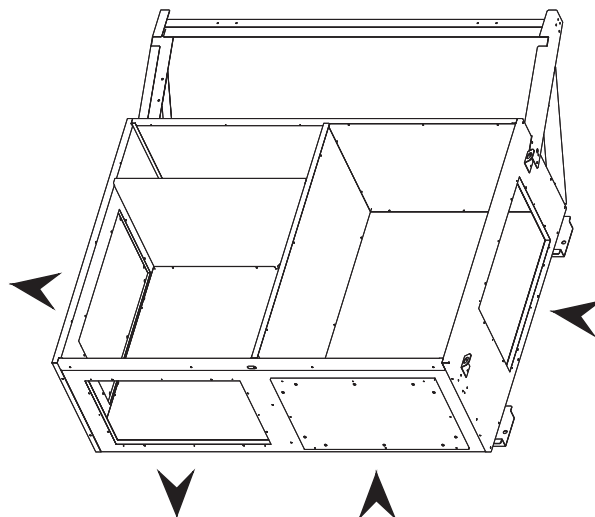

**WARNING :** all multidirectionnal flowcurb and horizontal extraction flow curb must be secured to the ground using existing fixing holes on the frame.

On receipt of new equipment please check the following points.

It is the customer's responsibility to ensure that the products are in good working order:

- The exterior has not been damaged in any way.
- The lifting and handling equipment are suitable for the equipment and comply with the specifications of the handling instructions enclosed here-in.
- Accessories ordered for on site installation have been delivered and are in good working order.
- The equipment supplied corresponds to the order and matches the delivery note.

If the product is damaged, exact details must be confirmed in writing by registered post to the shipping company within 48 hours of delivery (working days). A copy of the letter must be addressed to LENNOX and the supplier or distributor for information purposes. Failure to comply will invalidate any claim against the shipping company.

## Rating plate

The rating plate provides a complete reference for the model and ensures that the unit corresponds to the model ordered. It states the electrical power consumption of the unit on start-up, its rated power and its supply voltage. The supply voltage must not deviate beyond +10/-15 %. The start-up power is the maximum value likely to be achieved for the specified operational voltage. The customer must have a suitable electrical supply. It is therefore important to check whether the supply voltage stated on the unit's rating plate is compatible with that of the mains electrical supply. The rating plate also states the year of manufacture as well as the type of refrigerant used and the required charge for each compressor circuit.

<b>LENNOX</b>		Factory Mions Z.I LES MEURIERES 69780 MIONS FRANCE		<b>CE</b> 0052			
Unit type : BAM030SSM3M			Serial NR : 271597/01				
	Voltage (V)	Phase (Ph)	Frequency (Hz)	Current (A)			
Elec supply	400	3	50	Nominal	Starting		
Elec auxiliary	24	1	50	29	137		
		Min		Max			
		LP	HP	LP	HP		
Service Pressure (bar)		-1	-1	28	42		
Service Temperature (°C)		-20	-20	50	110		
Storage Temperature (°C)		-30		50			
LP : Low Pressure side / HP : High Pressure side							
Capacities (kW)		Ref charge (kg)				Dates	
Cooling	Heating	C1	C2	C3	C4	Prod.	Test
30	26.3	6.1	0	0	0	2011	14/02/2011
Fluid		Fluid group				Weight (kg)	
R410A		2				841	
This product is used for Air Conditioning. Contains fluorinated greenhouse gases covered by the Kyoto protocol. Hermetically sealed.							

## Storage

When units are delivered on site they are not always required immediately and are sometimes put into storage. In the event of medium to long-term storage, we recommend the following procedures:

- Ensure that there is no water in the hydraulic systems.
- Keep the heat exchanger covers in position.
- Keep protective plastic film in position.
- Ensure the electrical panels are closed.
- Keep all items and options supplied in a dry and clean place for future assembly before using the equipment.

## Maintenance key



On delivery we recommend that you keep the key which is attached to an eyebolt in a safe and accessible place. This allows you to open the panels for maintenance and installation work. The locks are ¼ turn + then tighter.



## Condensate drains

The condensate drains are not assembled when delivered and are stored in the electrical panel with their clamping collars. To assemble them, insert them on the condensate tray outlets and use a screwdriver to tighten the collars.



## Preliminary checks

Before installing the equipment, the following points **MUST** be checked:

- Have the forklift protections been removed?
- Is there sufficient space for the equipment?
- Is the surface on which the equipment is to be installed sufficiently solid to withstand its weight? A detailed study of the frame must be made beforehand.
- Do the supply and return ductwork openings excessively weaken the structure?
- Are there any obstructing items which could hinder the operation of the equipment?
- Does the electrical power available correspond to the equipment's electrical specifications?
- Is drainage provided for the condensate?
- Is there sufficient access for maintenance?
- Installation of the equipment could require different lifting methods which may vary with each installation (helicopter or crane). Have these been evaluated?
- Ensure that the unit is installed in accordance with the installation instructions and local applicable codes.
- Check to ensure that the refrigerant lines do not rub against the cabinet or against other refrigerant lines.

In general, make sure no obstacles (walls, trees or roof ledges) are obstructing the duct connections or hindering assembly and maintenance access.

## Installation requirements

The surface on which the equipment is to be installed must be clean and free of any obstacles which could hinder the flow of air to the condensers:

- Avoid uneven surfaces
- Avoid installing two units side by side or close to each other as this may restrict the airflow to the condensers.

Before installing a packaged rooftop unit it is important to understand:

- The direction of prevailing winds
- The direction and position of air flows.
- The external dimensions of the unit and the dimensions of the supply and return air connections.
- The arrangement of the doors and the space required to open them to access the various components.

## Connections

- Ensure that all the pipe-work crossing walls or roofs are secured, sealed and insulated.
- To avoid condensation problems, make sure that all pipes are insulated according to the temperatures of fluids and type of rooms.

NOTE: The packaging protection fitted on the finned surfaces must be removed prior to start up.

### Roof opening dimensions

The roof opening dimensions & maximum slope are defined according mechanical drawings.

### Sealing checks

**IMPORTANT note:** Prior to put the machine on the curbs make sure polyethylene foam is fitted on the curb upper flange side (must be delivered with the curb).

### Leveling adjustable roofcurbs

Above all, ensure that all the adjustable returns are facing outward. They could be turned inside-out for transport.

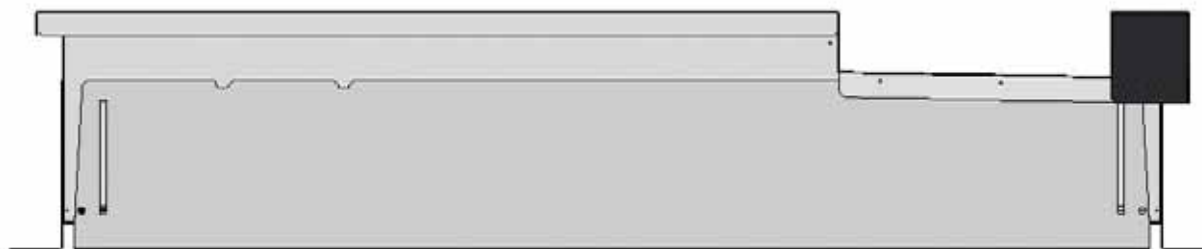

Place the roof mounting frame on the trimmer beam by first lining up the inlet and the outlet opening.

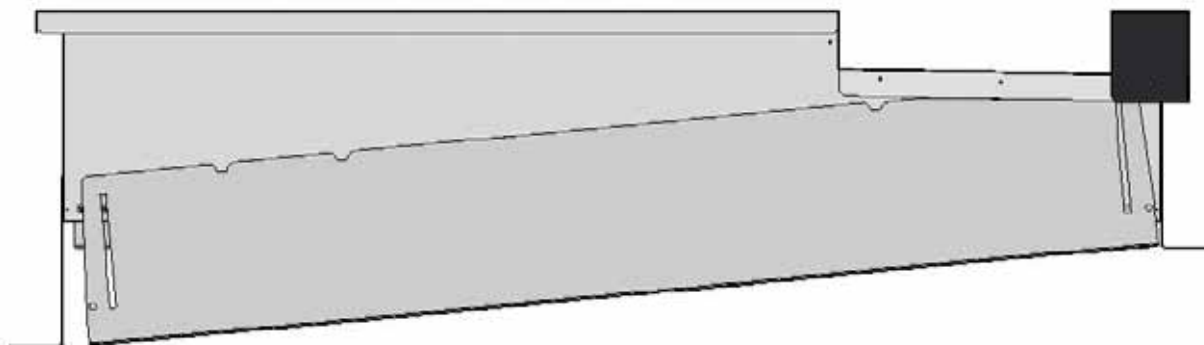

After levelling the frame, secure the adjustable returns on the trimmer.

**IMPORTANT NOTE: Securing the curb**

When the frame is correctly positioned, it is essential to secure the assembly with a disconnected stitched welded seam (20 to 30 mm every 200 mm) or self tapping screw diameter M6 along the outside or by using an alternative method.

## Positioning the rooftop on adjustable roofcurbs

**IMPORTANT note:** Prior to put the machine, make sure to put a polyethylene foam on the curb upper flange side (must be delivered in the curb package).

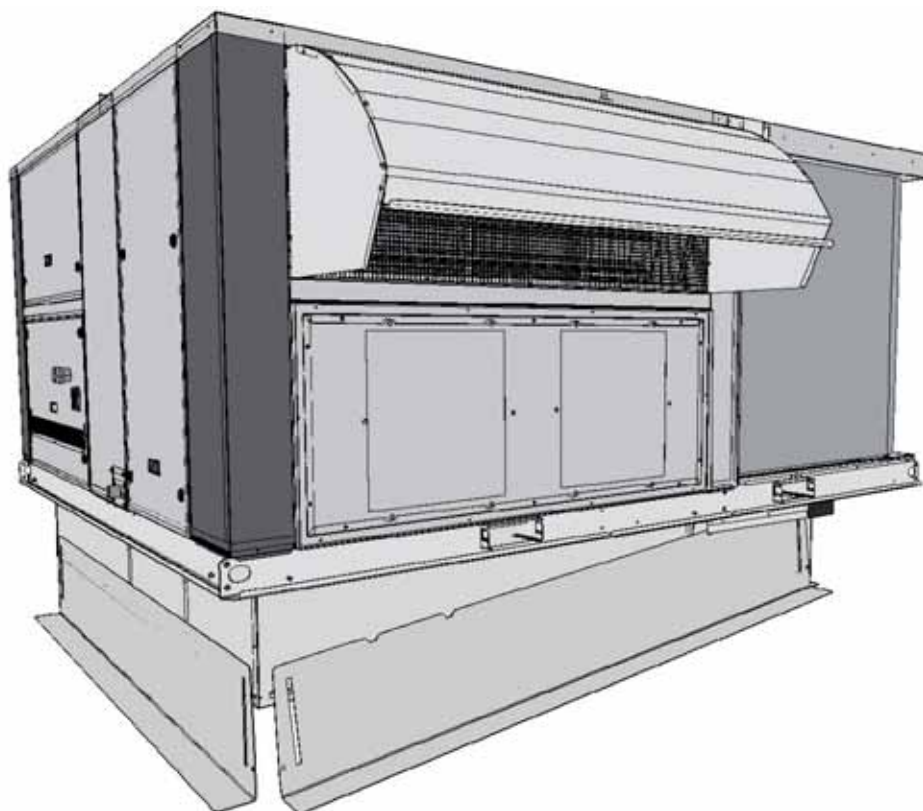
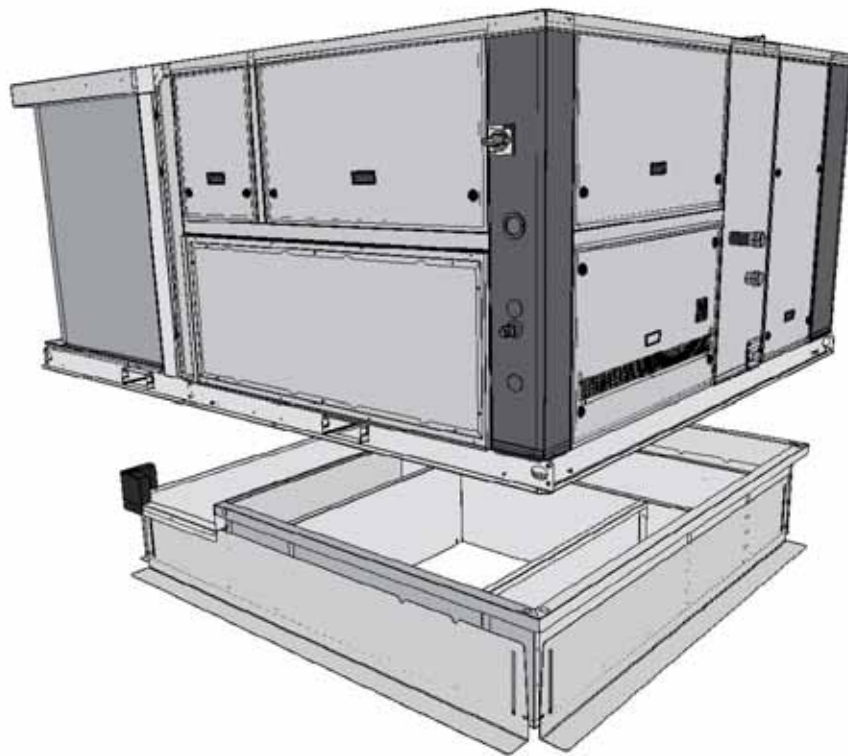

### Frame parts packing

Different parts are used in the assembly of this roof mounting frame. There are delivered stacked on a pallet.

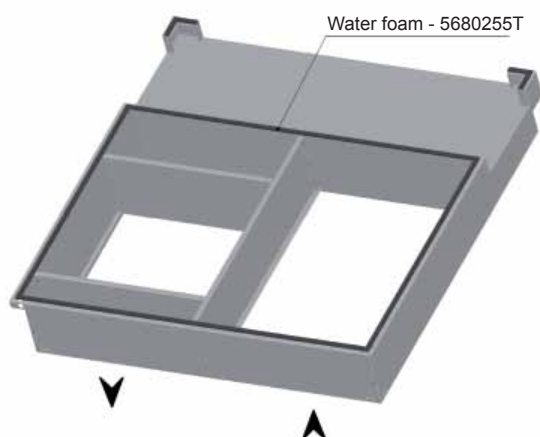
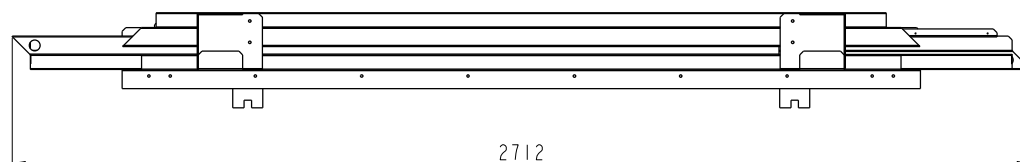
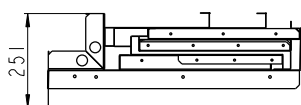
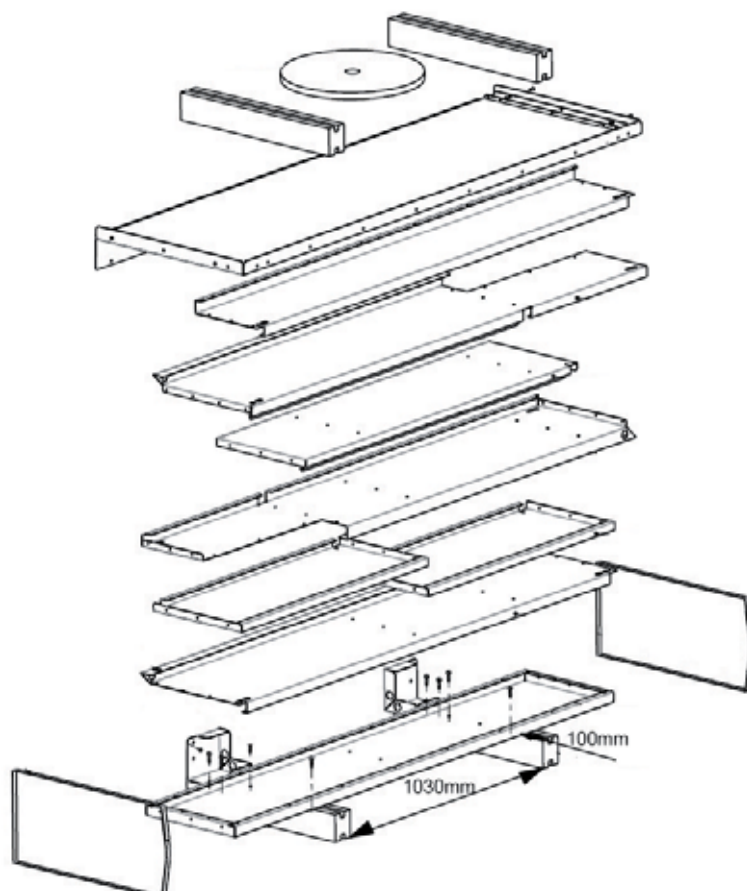

## Installation

The roof mounting frame provides support when the units are installed in down-flow configurations. The non adjustable, non assembled roof mounting frame can be installed directly on decks having adequate structural strength or on roof supports under deck. See page 24 for frame dimensions, location of supply and return air opening. NOTE: frame assembly must be installed flat, levelled within 5mm per linear meter in any direction.

## Assembly

The frame is supplied as a single package and shipped folded down for ease of transport and handling. It is easy field assembled as all parts required are supplied with the frame.

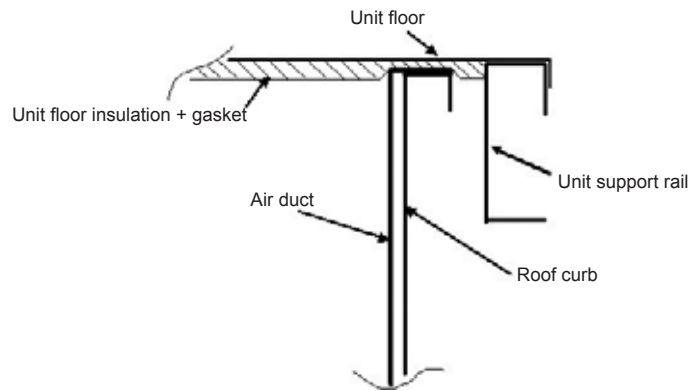

## Securing the frame

To ensure proper mating with units, it is mandatory that the roof mounting frame be squared to roof structure as follows:

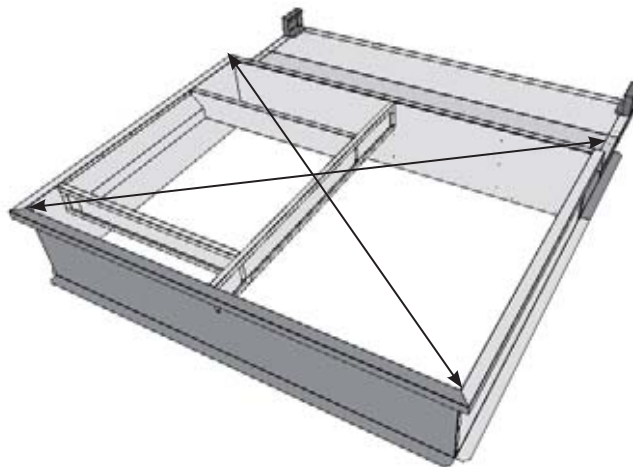

- With frame positioned levelled in the desired location on roof trusses, tack weld corner of frame.
- Measure frame diagonally from corner to corner as shown above. These Dimensions must be equal in order for the fame to be square.
- It is extremely important to sight frame from all corner to ensure it is not twisted across. Shim frame under any low side. The maximum slope tolerance is 5mm per linear meter in any direction.
- After the frame has been squared, straightened and shimmed, weld or secure the frame to the roof deck.

NOTE: It must be securely fastened to the roof as per local codes and regulations.

## Sealing checks

**IMPORTANT NOTE:** After assembling the kit curb and prior to put the machine on it, make sure to put a polyethylene foam on the curb upper flange side (must be delivered in the curb package).

## CURBING AND FLASHING

Outside of frame must be insulated with rigid type insulation. We recommend a minimum of 20 mm thick insulation.

Check that the insulation is continuous, counter flash and seal around the frame as shown.

**CAUTION:** To be effective, the upstream must end below the drop edge. Where pipes and electrical conduits extend through the roof, flashing must conform to local codes of practice

Before installing the equipment, make sure that seals are not damaged and check that the unit is secured to the mounting frame. Once in position, the bottom of the equipment must be horizontal. The installer must comply with local authority standards and specifications.

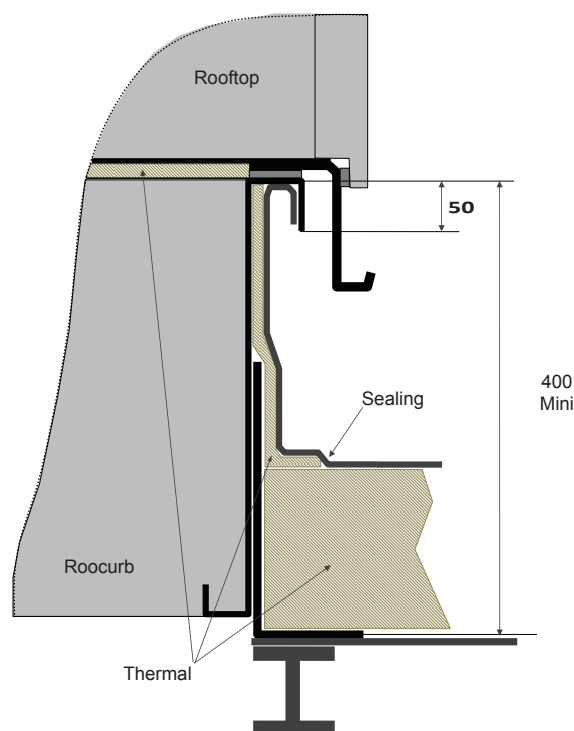

Heat recovery modules have following interests:

- in winter season and heating mode, the heat in the extract air is exchanged with the fresh air ;
- conversely, in summer season and cooling mode, the heat of the fresh air is transferred to the extract air.

HRMV and HRMH are two plates heat exchanger modules, that differ from each other by their horizontal or vertical configuration.

TRMO is a thermodynamic heat recovery module, included in the machine. Its main interests are:

- a variable fresh air rate from 25 to 100%,
- a high COP in winter when pre-heating the fresh air due to a favorable evaporating temperature, especially with high air flow rate ;
- a high EER in summer when pre-cooling the fresh air due to a favorable condensing temperature, especially with high air flow rate.

For those reasons, TRMO will be more suitable than HRMV/HRMH in areas where the difference between indoor temperature and outdoor temperature is low. For example, in Mediterranean areas, where winter temperatures are not very cold or summer temperatures are not very high.

**ERV + HRMV**

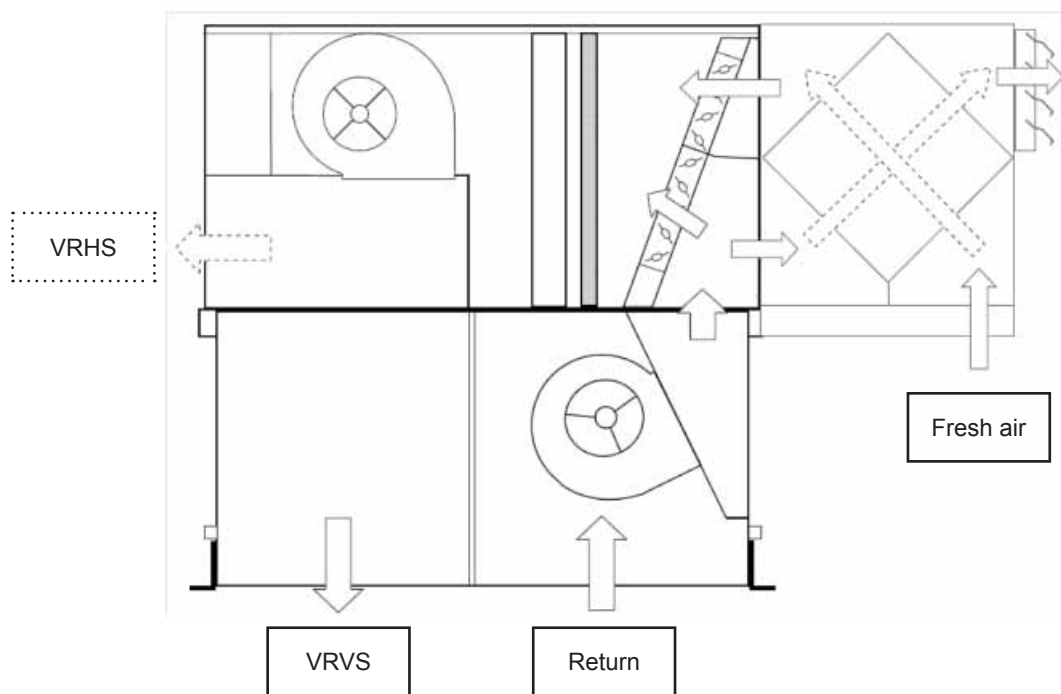

**EBHO + HRMH**

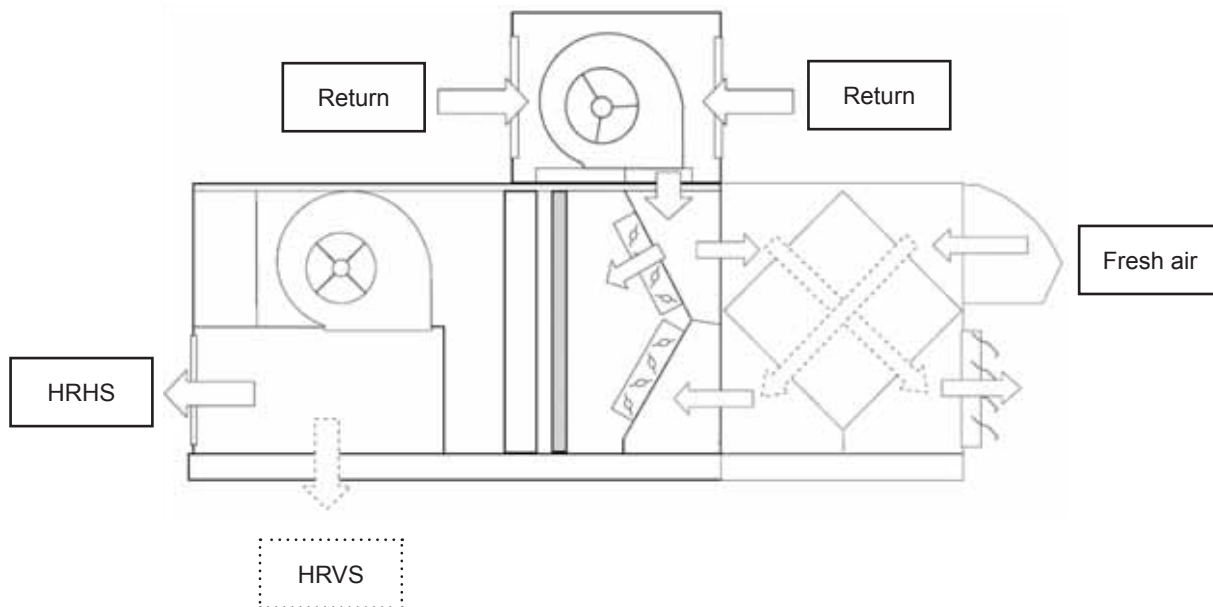



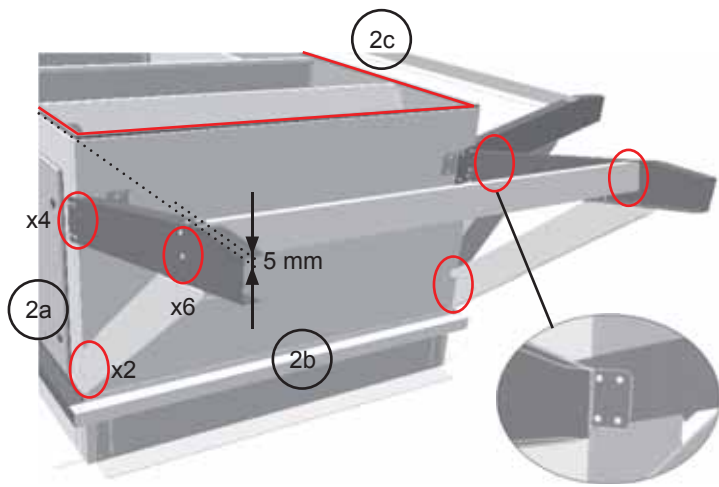

1. Install the flowcurb according to previous section.
2. Before installing the rooftop:
  - a. Fix the brackets (5 pieces) on the curb by 24 screws (6x16 mm);
  - b. ADJUST the position of the attachment bracket so that it is 5 mm above the support surface (without the foam);
  - c. Install the foam (25x10 mm) on the upper part of the flowcurb.

- 3.a. Fix the lower mounting bar of the heat recovery module using 4 screws (6x16 mm) and remove the side doors;
- b. Make sure that the foam is not damaged (20x15 mm).
4. Install the Rooftop and remove the lifting covers.

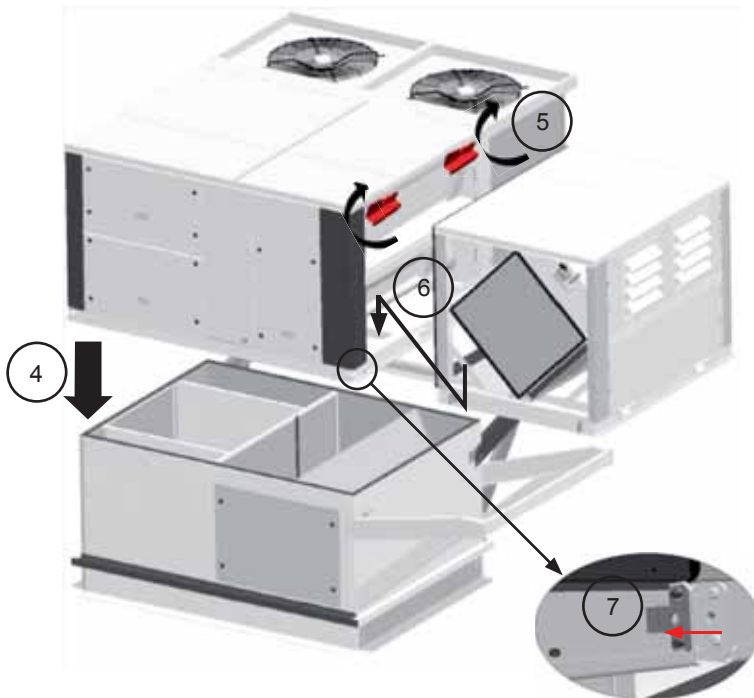
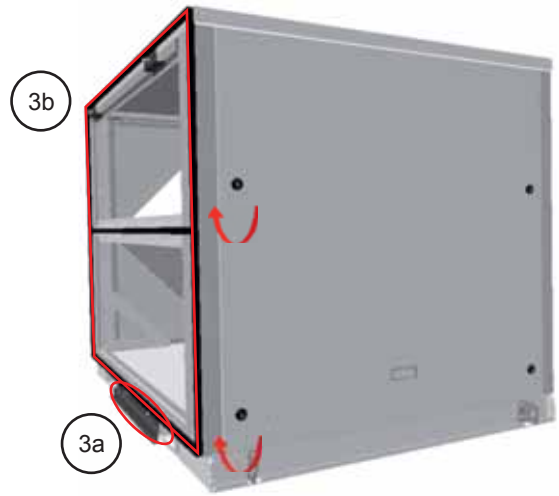

5. Place the two upper mounting bars through the two top slots.
6. Install the heat recovery module on the bracket by taking care to position properly the lower mounting bar.

Don't forget to remove the lifting covers from the module.

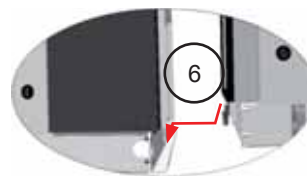

Detail A

7. Slide the 'T' plate into the lifting lug and place the bolt through it. On the opposite side, place also the bolt (detail A).



Detail B

8. Finally tighten the heat recovery module with the 4 bolts 8x60mm to compress the foam (2 bolts on the upper mounting bars (detail B) and the 2 bolts placed in step 7).

1. Make sure that the support surface enables to install the rooftop and the heat recovery module perfectly horizontal.
2. a. Fix the lower mounting bar of the heat recovery module using 4 screws (6x16 mm) and remove the side doors;
  - b. Make sure that the foam is not damaged (20x15 mm).
3. Install the rooftop and remove the lifting covers.
4. Place the two upper mounting bars through the two top slots.

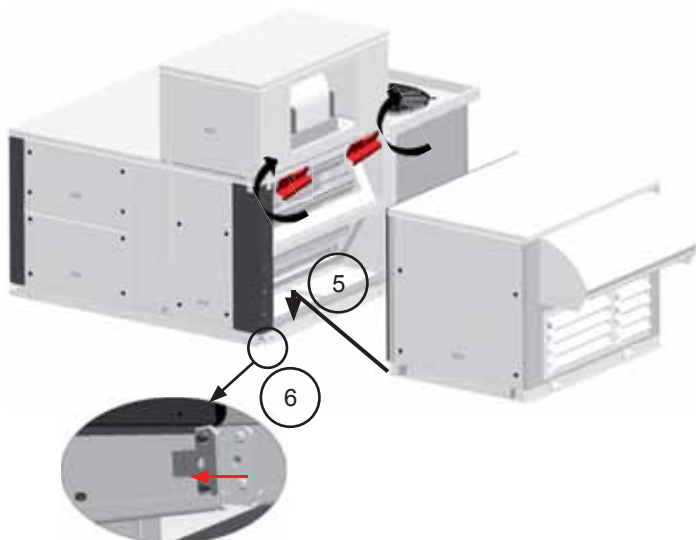
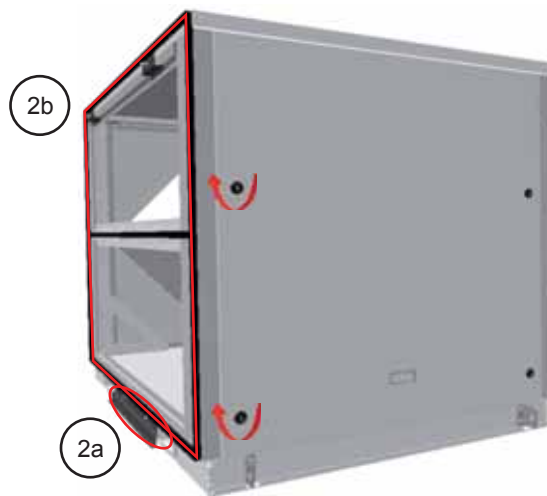

5. Install the heat recovery module by taking care to position properly the lower mounting bar.

Don't forget to remove the lifting covers from the module.

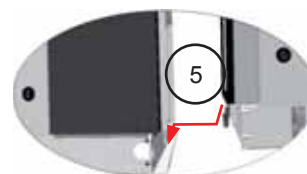

6. Slide the 'T' plate into the lifting lug and place the bolt through it. On the opposite side, place also the bolt ( detail A).

Detail A



Detail B

7. Finally tighten the heat recovery module with the 4 bolts 8x60mm to compress the foam (2 bolts on the upper mounting bars ( detail B ) and the 2 bolts placed in step 6).

## PLATE HEAT ELECTRICAL CONNECTIONS

Two components have to be connected in the space between the plate heat exchanger and the economizer:

- For the air pressostat, connect and tighten the 2 spade-tips on terminal 1 and 3 (no polarity) :
- For the actuator, assembly the two parts of the connector:



ERV + TRMO

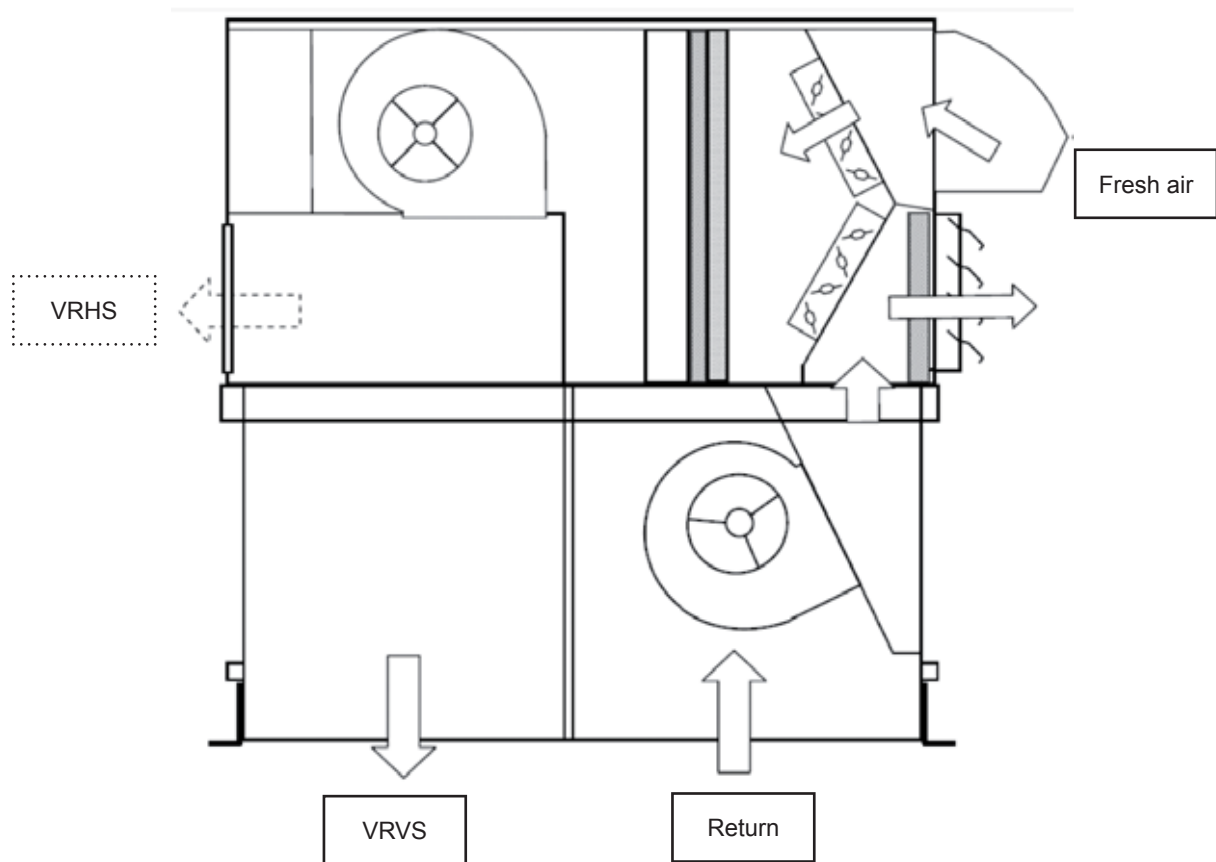

EBHO + TRMO

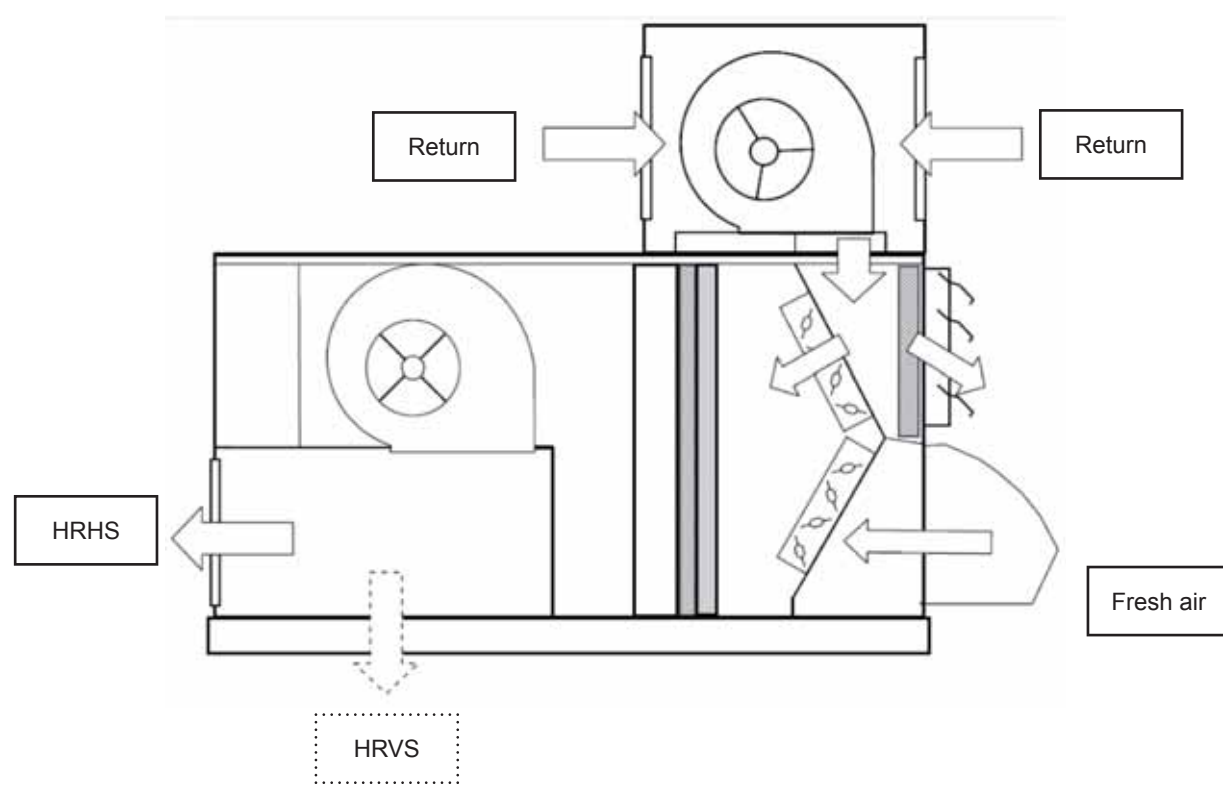

## 1. REFRIGERATION CIRCUIT



### Frigorific components access:

Compressor is located in the fix condenser part. Its access for electrical checking and pressure taps (HP and LP) is made through the screwed access door behind the hinged coil.

4-way valve, thermostatic expansion valve, dryer, and sensors are located on the e-Drive™ supply compartment.



### Electrical components:

- For D and E-box, specific TRMO components are located in the electrical box.
- For C-box, specific TRMO components are located on the back of the electrical box, and can be accessible from the supply e-Drive™ compartment.

### Circuit specifications:

TRMO			
Compressors	ABA054	ARA073	ARA081
Thermostatic expansion valves	TGEL10-6.5	TGEL10-9	TGEL10-9
Refrigerant load	2.5 kg	3.5 kg	4.5 kg

## 2. COMMISSIONING

### Electrical connections:

- All wire connections are factory made.

### Starting up:

- CLIMATIC™ configuration:
  - Power the unit
  - Check the configuration of the CLIMATIC™ 60 with the DS60 in expert mode. See § Control Manual / Configuration
- Flow rate settings:
  - Make sure that both supply and exhaust air flow are balanced. See section EBHO or ERVF. Balancing is correctly set if:
    - with Test = '**B.Nom 100%**': at 100% fresh air, set the exhaust Flow 3864 = supply flow 3333;
    - then switch Test = '**B.Nom 0%**':
      1. reduce coefficient 3866 until the louvers are closed;
      2. then if the flow (supply and exhaust) is far from the previous flow settings, set coefficient 3335;
      3. finally, repeat step 1 and 2 to obtain a constant flow whatever the fresh air mode.
    - same settings have to be realized for reduced flow - 3334 and 3865.

**WARNING! During the settings, wait until the economizer is fully closed or opened, since it takes 1-2 minutes to switch.**

- Start the TRMO circuit (circuit 3): switch Test='C3--Cool'
  - check the sense of rotation of the circuit 3 compressor;
  - check frigorific values (HP, LP, overheating and subcooling).
- Repeat the last operations with Test='C3--Heat'

### 3. SERVICE DIAGNOSTIC

#### Refrigeration

Low LP and LP cut out	Alarm 317: main frigorific issue	Lack of charge, obstructed components
	Alarm 327: too low LP	Freezing: wait that coil is defrosted by exhaust air; Air flow too low on evaporating side (too low speed rate / fouled filter or coil).
HP problem and HP cut out	Incorrect airflow rates	Check fan (exhaust or supply) function of the mode (Amps) and also filter.
	Refrigerant charge too high	Check the refrigerant charge load according to the refrigerant load table.
See also frigorific diagnostic of BALTIC™ III section 'Refrigeration'.		

#### Indoor or exhaust fan blower:

For both indoor supply fan and exhaust fan, same faults, causes and solutions than for BALTIC™ III are expected. See diagnostic of BALTIC™ III 'Indoor fan blower'.

### 4. SPARE PARTS LIST

Compressor	ARA054WAA	Comp.	4220463P
	ARA073WAA	Comp.	4220464R
	ARA081WAA	Comp.	4220465T
Indoor coil	ID C-box TRMO	Coil	4310508K
	ID D-box TRMO	Coil	4310509L
	ID E-box TRMO	Coil	4310510M
Exhaust coil	Exhaust coil TRMO	Coil	4310511N
	Exhaust coil TRMO	Coil	4310512P
	Exhaust coil TRMO	Coil	4310513R
Expansion valve	TGEL10-6.5 TRMO	Refrig.	4720940L
	TGEL10-9 TRMO	Refrig.	4720913W
4 way valve	STF0413G	Refrig.	4740100M
4 way valve coil	24V 50	Refrig.	4740103R
HP pressostat	HP 42bar OFF	Refrig.	4730184H
HP sensor	HP 4/20mA -1/45bar	Refrig.	4770207M
LP sensor	LP 4/20mA -1/20bar	Refrig.	4770208N
CLIMATIC™ extension	BE60	Control	4770668P
	Connector for BE60	Control	4770709Z

## 1. CONFIGURATION

Configuration of CLIMATIC™ 60 with the DS60 in expert mode for TRMO (with a modulating exhaust fan):

3813 RECOV. = Comp. for TRMO

3815 EXHAUST = Modulate for both ERVF & EBHO

3816 KIT

3817 Motor

3818 Fan

} to be checked function of your need

## 2. USE

### Protection:

- Operating envelop Protection: compressor stopped during 6 minutes.
  - **328**: min HP = 20.5°C condensation;
  - **329**: max HP = 62°C condensation;
  - **319**: min LP = between -24.5°C and 1.6°C (function of the condensation temperature) during 5 min => freezing or air flow on evaporator issue;
  - **327**: max LP = 26°C.
  - **317**: limit LP -27°C during 120 sec => frigorific failure (lack of refrigerant /closed components)
- Anti freezing Protection consist in defrosting the exhaust coil in heating mode with the extract air.

### Control

- No specific parameters have to be set for TRMO control.
- Operation:
  - TRMO runs if there is heating or cooling needs;
  - above 50% fresh air, TRMO compressor has priority to start;
  - under 15°C return or under 20% fresh air, TRMO compressor is not authorized to start.

# BALTIC™

## SERVICE MANUAL

Ref : BALTIC\_Service-IOM-0412-E

<b>INSTALLATION MANUAL</b>	
Safety codes & regulations	28
<b>COMMISSIONING RECORD SHEET</b>	30
<b>REFRIGERANT TRANSACTIONS LOGBOOK: EUROPEAN REGULATION N° 842/2006</b>	32
<b>PRESSURE EQUIPEMENT DIRECTIVE INFORMATIONS</b>	35
<b>COMMISSIONING</b>	
Before turning on the power	36
Wire connection tightness checks	36
CLIMATIC™ configuration	36
Powering the unit	36
<b>EDRIVE™ VENTILATION</b>	37
<b>FRESH AIR HOOD</b>	41
<b>FILTERS</b>	42
<b>REFRIGERATION CIRCUIT</b>	43
<b>HEATING OPTIONS</b>	
Hot water coils	44
Electric heater	45
Electrical preheater	46
<b>GAS BURNERS</b>	
Preliminary checks before start-up	47
Starting up the gas burner	47
Standard start-up chronology	48
Burner safety checks	51
Gas module	55
<b>MODULATING GAS BURNERS</b>	
Modulating gas (under patent inpi mai 2004)	56
Burner safety checks	59
Gas burner troubleshooting	59
Disassembling of gas burner for maintenance purposes	59
Modulating gas	59
<b>RECOVERY WATER COIL</b>	60
<b>SERVICE DIAGNOSTIC</b>	61
<b>SPARE PART LIST</b>	64
<b>WARRANTY</b>	67
<b>MAINTENANCE PLAN</b>	68

## Safety codes & regulations

THE UNIT MUST BE INSTALLED IN ACCORDANCE WITH LOCAL SAFETY CODES AND REGULATIONS AND CAN ONLY BE USED IN WELL VENTILLATED AREA.

PLEASE READ CAREFULLY THE MANUFACTURER'S INSTRUCTIONS BEFORE STARTING THIS UNIT.

INSPECTIONS AND REQUALIFICATION ACCORDING PRESSURE EQUIPMENT DIRECTIVE MUST FOLLOW THE LOCAL REGULATIONS WHERE THE UNIT IS INSTALLED.

### Important note for unit fitted with gas burner:

THIS MANUAL IS ONLY VALID FOR UNITS DISPLAYING THE FOLLOWING CODES:

GB

IR

GR

DA

NO

FI

IS

In case these symbols are not displayed on the unit, please refer to the technical documentation which will eventually detail any modifications required to the installation of the unit in a particular country.

- If machine is including gas burner, minimum clearance around the unit must be at least 8 m to allow a proper gas flue dilution. If not possible, the fresh air intake must be ducted at least 8 m away from the gas burner exhaust.
- The gas burner air intake and exhaust chimney must not be modified or ducted.
- Before commissioning this type of unit, it's mandatory to ensure that the gas distribution system is compatible with the adjustments and settings of the unit.
- Gas module can only be used for outdoor installations.
- Any work on gas module must be carried out by qualified engineer.

All the technical and technological information contained in this manual, including any drawing and technical descriptions provided by us, remain the property of LENNOX and must not be utilised (except in operation of this product), reproduced, issued to or made available to third parties without the prior written agreement of LENNOX. The technical information and specifications contained in this manual are for reference only. The manufacturer reserves the right to modify these without warning and without obligation to modify equipment already sold.

### All units are compliant with the PED directive 97-23/CE

### The following note must be followed carefully

**All work on the unit must be carried out by a qualified and authorised employee.**

Non-compliance with the following instructions may result in injury or serious accidents.

#### **Work on the unit:**

- The unit shall be isolated from the electrical supply by disconnection and locking using the main isolating switch.
- Workers shall wear the appropriate personal protective equipment (helmet, gloves, glasses, etc.).

#### **Work on the electrical system:**

- Work on electric components shall be performed with the power off (see below) by employees having valid electrical qualification and authorisation.

#### **Work on the refrigerating circuit(s):**

- Monitoring of the pressures, draining and filling of the system under pressure shall be carried out using connections provided for this purpose and suitable equipment.
- To prevent the risk of explosion due to spraying of coolant and oil, the relevant circuit shall be drained and at zero pressure before any disassembly or unbrazing of the refrigerating parts takes place.
- There is a residual risk of pressure build-up by degassing the oil or by heating the exchangers after the circuit has been drained.



Zero pressure shall be maintained by venting the drain connection to the atmosphere on the low pressure side.

- The brazing shall be carried out by a qualified brazier. The brazing shall comply with standard NF EN1044 (minimum 30% silver).

## EMC DIRECTIVE COMPLIANCE

### WARNING:

This equipment is an "A class" according to CEM Directive. In an industrial environment, this device can create radio electrical noise. In this case, the owner can be asked to take appropriated actions.

This applies to all machine installed with nominal amps below <75A:

- The short-circuit rate  $R_{sce}=33$  is defined in the EN61000-3-12 standard relative to the harmonics readings on the supply network. The appliances compliant with the harmonic current limits equivalent to  $R_{sce}=33$  can be connected in whatever connection point of the main supply system.
- The maximal allowable impedance of the main supply system  $Z_{max}=0.051W$  is defined by EN 61000-3-11 standard relative to the voltage variation, fluctuation and flicker readings. The connection to the supply is a conditional connection submitted to the preliminary agreement of the power supply local provider.

### Replacing components:

- In order to maintain CE marking compliance, replacement of components shall be carried out using spare parts, or using parts approved by LENNOX.
- Only the coolant shown on the manufacturer's nameplate shall be used, to the exclusion of all other products (mix of coolants, hydrocarbons, etc.).

### CAUTION:

**In the event of fire, refrigerating circuits can cause an explosion and spray coolant gas and oil.**

### Transport – Handling- Access:

- Never lift the unit without forklift protections
- An approach ramp must be installed if the unit's installation requirements tell that it's necessary to reach the main switch, the electrical cabinet, the compressor and the ventilation compartment. This recommendation is valid for all type of installations.
- It is strictly forbidden to walk or store equipment or material on top of the rooftop unit

### Rooftop installation in heavy wind locations

- The roofcurbs (vertical & horizontal) and rooftops installations are designed to withstand winds up to 80 km/h. Above this limit, it's recommended to take appropriate actions to secure the installation.
- Ensure the fresh air inlet does not face prevailing wind direction.

### Elbow or section changes in ductworks next to the rooftop

- Whatever the supply configuration is, respect a minimal duct's length of 2 m before any elbow or any duct's section change.
- Directional vanes must be fitted inside any elbow fitted in return or supply ductwork closer than 5 meter to the machine connection flanges.

### Filters:

- Do the filters fire classification's choice according to local regulations.

### Fan compartment:

- Stop the power before accessing the fan compartment.

### Gas:

- Any work on gas module must be carried out by qualified personnel
- A unit with gas module must be installed in accordance with local safety codes and regulations and can only be used for outdoor installation.

*The technical information and specifications contained in this manual are for reference only. The manufacturer reserves the right to modify these without warning and without obligation to modify equipment already sold.*

<b>Site details</b>		Controller	
Site		Model	
Unit Ref		Serial No	
Installer		Refrigerant	

(1) ROOF INSTALLATION

Sufficient Access OK Yes <input type="checkbox"/> No <input type="checkbox"/>	Condensate drain fitted Yes <input type="checkbox"/> No <input type="checkbox"/>	Roofcurb OK <input type="checkbox"/> Not OK <input type="checkbox"/>
----------------------------------------------------------------------------------	-------------------------------------------------------------------------------------	-------------------------------------------------------------------------

(2) CONNECTIONS CHECK

Phase check Yes <input type="checkbox"/> No <input type="checkbox"/>	Voltage between Phases	1/2	2/3	1/3
-------------------------------------------------------------------------	------------------------	-----	-----	-----

(3) CLIMATIC™ CONFIGURATION CHECK

CLIMATIC™ 60 Configured according to the options and specifications Yes <input type="checkbox"/> No <input type="checkbox"/>
---------------------------------------------------------------------------------------------------------------------------------

(4) SUPPLY BLOWER SECTION

Type		N°1		N°2	
Power displayed on plate	kW				
Voltage displayed on plate	V				
Current displayed on plate	A				
Fan type		Forward <input type="checkbox"/>	Backward <input type="checkbox"/>	Forward <input type="checkbox"/>	Backward <input type="checkbox"/>
Displayed coupling ref	mm				
Alignment checked		Yes <input type="checkbox"/>	No <input type="checkbox"/>	Yes <input type="checkbox"/>	No <input type="checkbox"/>
Fan speed	rpm				
Averaged measured amps	A				
Shaft mechanical mower (Refer to airflow balancing)	W				
Operating point checked		Yes <input type="checkbox"/>	No <input type="checkbox"/>	Yes <input type="checkbox"/>	No <input type="checkbox"/>
Read airflow	m³/h				

(5) AIRFLOW PRESSURE SENSOR CHECK

Measured pressure drop		Set points adjusted			
		Yes <input type="checkbox"/>	No <input type="checkbox"/>		
	mBar	If yes enter new values			
		3410:	3411:	3412:	

(6) EXTERNAL SENSOR CHECKS

Check electrical connections	Yes <input type="checkbox"/> No <input type="checkbox"/>	Check and record temp. in menu 2110		Yes <input type="checkbox"/> No <input type="checkbox"/>
		100% Fresh Air	100% return Air	
Supply temperature		°C		°C
Return temperature		°C		°C
Outdoor temperature		°C		°C

(7) MIXING AIR DAMPERS CHECKS

Dampers open & close freely		% Minimum FA	Power exhaust checked		Enthalpy sensor(s) checked	
Yes <input type="checkbox"/>	No <input type="checkbox"/>		%	Yes <input type="checkbox"/>	No <input type="checkbox"/>	Yes <input type="checkbox"/>

(8) REFRIGERATION SECTION

Outdoor fan motor current						Check rotation									
Motor 1	L1:	A	L2:	A	L3:	A	Yes	<input type="checkbox"/>	No	<input type="checkbox"/>	Compressor voltage				
Motor 2	L1:	A	L2:	A	L3:	A	Yes	<input type="checkbox"/>	No	<input type="checkbox"/>					
Motor 3	L1:	A	L2:	A	L3:	A	Yes	<input type="checkbox"/>	No	<input type="checkbox"/>	Comp1:	V			
Motor 4	L1:	A	L2:	A	L3:	A	Yes	<input type="checkbox"/>	No	<input type="checkbox"/>	Comp1:	V			
Motor 5	L1:	A	L2:	A	L3:	A	Yes	<input type="checkbox"/>	No	<input type="checkbox"/>	Comp3:	V			
Motor 6	L1:	A	L2:	A	L3:	A	Yes	<input type="checkbox"/>	No	<input type="checkbox"/>	Comp4:	V			
Compressor amps - COOLING						Pressures & temperatures									
			Phase 1	Phase 2	Phase 3	Temperatures				Pressures					
						Suction		Disch		LP		HP			
			A	A	A	°C		°C		Bar		Bar			
			A	A	A	°C		°C		Bar		Bar			
			A	A	A	°C		°C		Bar		Bar			
			A	A	A	°C		°C		Bar		Bar			
Check Reversing valves			Valve 1:	Yes	<input type="checkbox"/>	No	<input type="checkbox"/>	Valve 3:	Yes	<input type="checkbox"/>	No	<input type="checkbox"/>			
			Valve 2:	Yes	<input type="checkbox"/>	No	<input type="checkbox"/>	Valve 4:	Yes	<input type="checkbox"/>	No	<input type="checkbox"/>			
Compressor amps - HEATING						Pressures & temperatures									
			Phase 1	Phase 2	Phase 3	Temperatures				Pressures					
						Suction		Disch		LP		HP			
			A	A	A	°C		°C		Bar		Bar			
			A	A	A	°C		°C		Bar		Bar			
			A	A	A	°C		°C		Bar		Bar			
			A	A	A	°C		°C		Bar		Bar			
HP cut out:						Bar		LP cut out:						Bar	
Refrigerant charge						C1:	kg	C2:	kg	C3:	kg	C4:	kg		

(9) ELECTRIC HEATER SECTION

Type			Serial No		
AMPS 1 <sup>st</sup> stage (BAL TIC™)			AMPS 2 <sup>nd</sup> stage (BAL TIC™)		
1	2	3	1	2	3

(10) HOT WATER COIL SECTION

Check Three Way Valve Movement	
Yes	<input type="checkbox"/>
No	<input type="checkbox"/>

(11) GAS HEATING SECTION

Gas Burner N°1:				Gas Burner N°2:			
Size:		Valve type:		Size:		Valve type:	
Pipe size:		Gas type: G		Pipe size:		Gas type: G	
Line press:		Drop test Yes <input type="checkbox"/> No <input type="checkbox"/>		Line press:		Drop test Yes <input type="checkbox"/> No <input type="checkbox"/>	
Check manifold pressure:				Check manifold pressure:			
High fire		Low fire		High fire		Low fire	
Pressure cut out airflow press switch		mBar/Pa		Pressure cut out airflow press switch		mBar/Pa	
Motor amps: A	Flue temp: °C	CO <sub>2</sub> %: %	CO ppm: %	Motor amps: A	Flue temp: °C	CO <sub>2</sub> %: %	CO ppm: %

(12) REMOTE CONTROL BMS CHECK

Type:		Sensor type:		Interconnect wiring checked:	
				Yes	<input type="checkbox"/>
				No	<input type="checkbox"/>







### CE marking compliance

These units are CE marked according to Pressure Equipment Directive.

Section	Phase	PS (bars gauge)
Suction	Vapor	29,5
Discharge	Vapor	42 bar R410A
Liquid	Liquid / Vapor	42 bar R410A

### Name plate example

		Factory Mions Z.I LES MEURIERES 69780 MIONS FRANCE					
Unit type : BAM030SSM3M			Serial NR : 271597/01				
	Voltage (V)	Phase (Ph)	Frequency (Hz)	Current (A)			
Elec supply	400	3	50	Nominal	Starting		
Elec auxiliary	24	1	50	29	137		
	Min		Max				
	LP	HP	LP	HP			
Service Pressure (bar)	-1	-1	28	42			
Service Temperature (°C)	-20	-20	50	110			
Storage Temperature (°C)	-30		50				
LP : Low Pressure side / HP : High Pressure side							
Capacities (kW)		Ref charge (kg)				Dates	
Cooling	Heating	C1	C2	C3	C4	Prod.	Test
30	26.3	6.1	0	0	0	2011	14/02/2011
Fluid		Fluid group			Weight (kg)		
R410A		2			841		
This product is used for Air Conditioning. Contains fluorinated greenhouse gases covered by the Kyoto protocol. Hermetically sealed.							

### Periodical visit according european pressure equipment directive

According to Pressure Equipments Directive, periodical controls on site are expected on equipments equal or above category II.

**WARNING: commissioning must only be carried out by trained refrigeration engineers whom qualification certificates are compliant with the local regulation**

## Before turning on the power

**WARNING: ensure that the power supply includes 3 phases with no neutral**

Ensure that the power supply between the building and the unit meets local authority standards and that the cable specification satisfies the start-up and operating conditions displayed on the name plate.

## Wire connection tightness checks

**WARNING: check the wire connection tightness**

Check the following wire connections for tightness:

- Main switch connections,
- Mains wires linked to the contactors and circuit breakers
- Cables in the 24V control supply circuit.

## CLIMATIC™ configuration

See CLIMATIC™ section

## Powering the unit

Power up the unit by closing the isolator switch (if fitted).

At this point the blower should start unless the CLIMATIC™ does not energise the contactor. Once the fan is running, check the rotation direction. Refer to the rotation arrow located on the fan.

The fans and compressors direction of rotation is checked during the end of line test. They should therefore all turn in either the right or wrong direction.

**WARNING: a compressor rotating in the wrong direction will fail shortly.**

If the fan turns in the wrong direction (the right direction is shown below), disconnect the main power supply to the machine at the building's mains switch, reverse two phases and repeat the above procedure.

Close all circuit breakers and power up the unit.

If now only one of the components rotates in the wrong direction, disconnect the power supply at the machine's isolator switch (if fitted) and reverse two of the component's phases on the terminal within the electrical panel.

Check the current drawn against the rated values, in particular on the supply fan.

If the readings on the fan are outside the specified limits, this usually indicates excessive air flow which will affect the life expectancy. In this case reduce rpm using eDrive™.

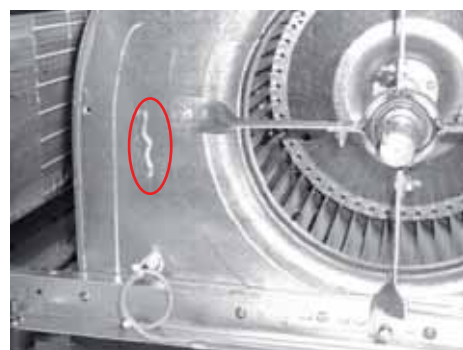



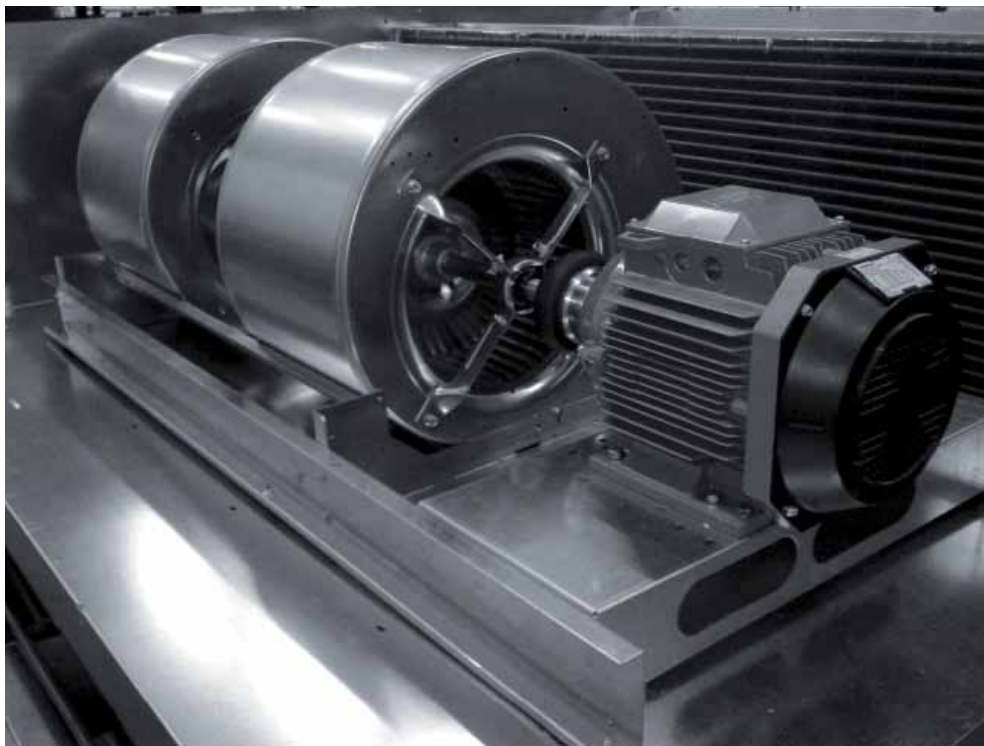

### eDrive™ assembly instructions & specification

The flexible elastomeric tire is removable without removing the plates

The material is natural rubber

Temperature range from  $-42^{\circ}\text{C}$  to  $+82^{\circ}\text{C}$

Easy to assemble

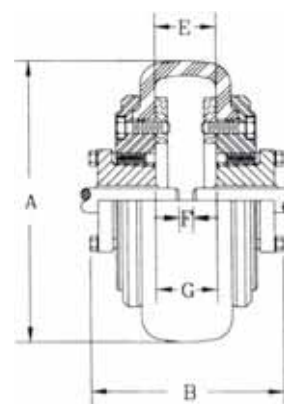
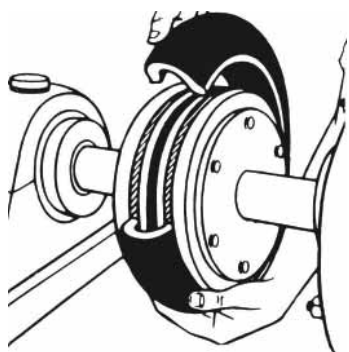

### eDrive™ mounting

eDrive™ assembly is designed to have no adjustment to be made inside the machine  
 In case of vertical misalignment one could use metallic washer located under the motor to adjust height

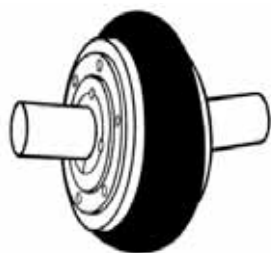

Max angular misalignment 4°

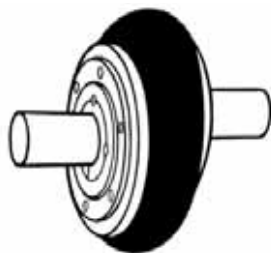

Max radial misalignment 3mm

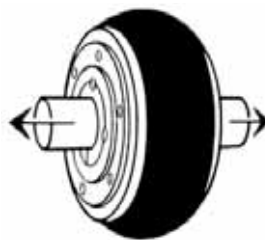

Max axial range 8 mm



Vibration absorption

### eDrive™ coupling dimensions

Coupling							
Machine size	Motor size kW	Motor shaft diameter mm	Fan shaft diameter mm	Coupling reference	Coupling type PP	Motor motor bushing ref	Fan taper Ref
C box	1,5	24	25	PV40	2 x Taper lock bushing	28-20 al24	28-20 al25
C box	2,2	28	25	PV40	2 x Taper lock bushing	28-20 al28	28-20 al25
C box	3	28	25	PV40	2 x Taper lock bushing	28-20 al28	28-20 al25
C box	4	28	25	PV40	2 x Taper lock bushing	28-20 al28	28-20 al25
C box	5,5	38	25	PV60	2 x Taper lock bushing	40-25 a38	40-25 al25
D box	2,2	28	30	PV50	1 Taper lock bushing + D30	30-25 al28	30-25 al30
D box	3	28	30	PV50	1 Taper lock bushing + D30	30-25 al28	30-25 al30
D box	4	28	30	PV50	1 Taper lock bushing + D30	30-25 al28	30-25 al30
D&E box	5,5 to 7,5	38	30	PVP50	1 Taper lock bushing + D38		30-25 al30
E box	9 to 11	38	40	PV 60	2 x Taper lock bushing	40-25 al 38	40-25 al 40

### eDrive™ airflow reading

eDrive is controlling the airflow within the operating range of each kit.  
 Airflow rate calculation inputs are rpm and power absorbed output read on the inverter variable bus.  
 The airflow rate calculation formula is calibrated according lab tests.

## eDrive™ is protecting the fan & motor against over-speed & over-amps

eDrive™ is designed to keep motor and fan in its available operating range thanks to the kit configuration selected in CLIMATIC™ 60 control. The CLIMATIC™ control is limiting rpm & absorbed power. The table below shows the operating ranges per box and kit size.

### eDrive™ unit operating ranges

Box	Fan type	Motor kW	Efficiency	Kit	Comment	rpm min	rpm max	Qv min	Qv max	Imax
C Box BAH BAC	AT 15-11 S	1,5	0,80	K1		553	962	3600	4800	3,6
	AT 15-11 S	2	0,83	K2		610	1170	3750	6000	4,9
	AT 15-11 S	3	0,85	K3		697	1330	4500	7050	6,6
	AT 15-11 S	4	0,85	K4		78	1371	5550	8250	8,4
	AT 15-11 S	5,5	0,87	K5		882	1417	7200	8400	12,2
D Box BAH BAC	ADH 355 L	2,2	0,83	K1		581	939	5500	6900	4,9
	ADH 355 L	3	0,85	K2		660	1208	5500	8300	6,6
	ADH 355 L	4	0,85	K3		738	1396	6100	9700	8,4
	ADH 355 L	5,5	0,87	K4		823	1439	7100	11500	12,2
	ADH 355 L	7,5	0,88	K5		938	1501	9500	13100	16,3
E Box BAH BAC	AT 15-11 G2L	5,5	0,87	K1	Fan shaft D30	648	1302	10000	13500	12,2
	AT 15-11 G2L	7,5	0,88	K2	Fan shaft D30	774	1385	10000	16000	16,3
	AT 15-11 G2L	9	0,88	K3	Fan shaft D40	880	1378	10000	17750	17,6
	AT 15-11 G2L	9	0,88	K4	Fan shaft D30	880	1417	10000	19000	17,6
	AT 15-11 G2L	11	0,89	K5	Fan shaft D40	911	1417	10000	19000	23

### Gas unit eDrive™ operating ranges

Box	Fan type	Motor kW	Efficiency	Kit	Comment	rpm min	rpm max	Qv min	Qv max	Imax
C Box BAH BAC	AT 15-11 S	1,5	0,80	K1		592	949	3600	4650	3,6
	AT 15-11 S	2	0,83	K2		690	1155	3750	5700	4,9
	AT 15-11 S	3	0,85	K3		788	1386	4500	6900	6,6
	AT 15-11 S	4	0,85	K4		907	1449	5400	7950	8,4
	AT 15-11 S	5,5	0,87	K5		1015	1533	6750	8400	12,2
D Box BAH BAC	ADH 355 L	2,2	0,83	K1	ADHE 355	651	929	5500	6500	4,9
	ADH 355 L	3	0,85	K2	ADHE 355	727	1206	5500	7900	6,6
	ADH 355 L	4	0,85	K3	ADHE 355	826	1409	6100	9300	8,4
	ADH 355 L	5,5	0,87	K4	ADHE 355	930	1499	7100	11100	12,2
	ADH 355 L	7,5	0,88	K5	ADHE 355	1070	1578	8700	13100	16,3
E Box BAH BAC	AT 15-11 G2L	5,5	0,87	K1	Axe D30	760	1310	10000	13000	12,2
	AT 15-11 G2L	7,5	0,88	K2	Axe D30	898	1431	10000	15250	16,3
	AT 15-11 G2L	9	0,88	K3	Axe D30	994	1476	10000	17250	17,6
	AT 15-11 G2L	9	0,88	K4	Axe D30	994	1476	10000	17250	17,6
	AT 15-11 G2L	11	0,89	K5	Axe D30	1072	1525	10000	19000	23

## eDrive™ fan inverter configuration

eDrive™ Inverter configuration is prepared in the factory to communicate with CAREL & to be configured specifically for the customer machine.

eDrive™ Fan inverter parameters are configured via the CLIMATIC™ 60 unit configuration (See CLIMATIC™ Section).

This configuration is selecting the proper parameters to run eDrive™ in its operating range depending on fan type & motor size.

If ever, the Inverter loose fan control (No Fan or Wrong fan speed & Compressor or Heating stay on), one may check the Inverter configuration as below:

“0.0” will be displayed in this case on the Inverter instead of the regular “0” or “xxx” rpm

Switch to unlock mode:

F700 = 0

F732 = 0

On Inverter, set the TYP parameter to 3 value. (reinitialize the Inverter to the default values) then configure the following setpoints:

CMOD=2

FMOD=4

F800=1

F801=0

F802=11

F803=0

Then switch OFF the whole machine & then switch ON.

Then the CLIMATIC™ is going to send all the proper machine configuration to Inverter (motor size, fan type, I<sub>max</sub>, safety parameters) .

## Installing

The fresh air hood has to be opened and secured during commissioning.  
The 3 parts of the fresh air hood have to be assembled thanks to self tapping screws delivered in the spare part box.  
Check the proper position of the black seal on the top of the hood cover.

## Wind direction

The prevailing wind has to be taken into account while choosing the machine position on the building roof.  
It's highly recommended to avoid putting the fresh air hood in the prevailing wind direction to avoid water ingress risks.  
If this is not possible please contact us to require specific water droplet strainer in the hood section.

**WARNING: the fresh air hood cover can hurt your head if you don't pay attention while turning around the unit.**



## Filter replacement

After opening the filter access panel, lift the filter retaining log. The filters can then be removed and replaced easily by sliding the dirty filters out and clean ones in.



The CLIMATIC™ 60 controller can monitor the pressure drop across the filter

The following set points can be adjusted depending on the installation.

- “Airflow” in page **3343** = 25Pa by default
- “No filter “ in page **3344** = 50Pa by default
- “Dirty Filter” in page **3345** = 250Pa by default

The actual pressure drop measured across the coil can be read on the CLIMATIC™ Display in menu **3342**.

The following faults may be identified

- Fault code **001** AIRFLOW FAILURE, if measured  $\Delta P$  across the filter and coil is below the value set in page **3343**
- Fault code **004** DIRTY FILTERS, if measured  $\Delta P$  across the filter and coil is above the value set in page **3344**
- Fault code **005** MISSING FILTERS, if measured  $\Delta P$  across the filter and coil is below the value set in page **3345**.

### Electronic expansion valve

2 electronic valves types are fitted on BALTIC™: E2V & E3V

	Cbox				Dbox				Ebox	
Model designation	24	30	38	42	45	52	57	65	75	85
Reference	E2V30	E2V30	E2V30	E3V45	E2V30	E2V30	E2V30	E2V30	E2V30	E3V45

### EEV adjustments

EEV allows the control of superheat in biflow operation (see CLIMATIC™ 60 sections).

### E2V welding instructions

Electronic expansion valves are sensitive to dust – strainers must be used in case of replacing.

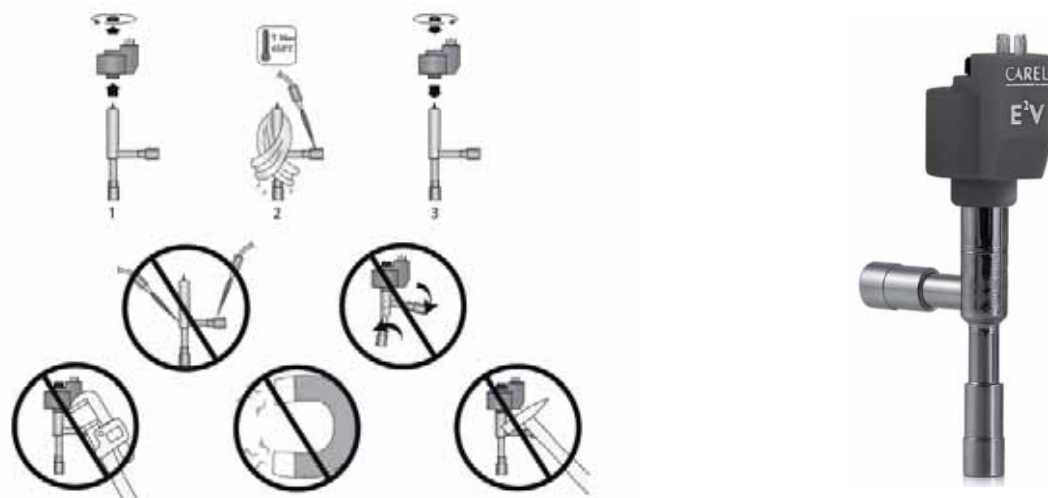

### E3V welding instructions

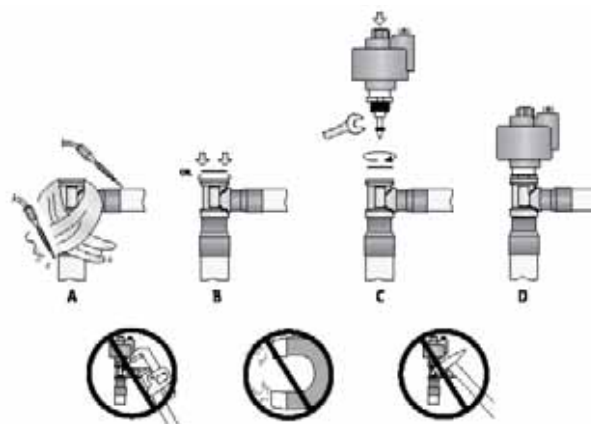

## Hot water coils

The hot water coil is fitted with a three way proportional valve . Two spanners must be used to tighten the connections. One spanner must maintain the valve body when connecting the pipe-work to the main. Failure to do so may damage the pipes joints and invalidates the warranty.

Filling up and starting the system

- Adjust the control for Heating by reducing the simulated ambient temperature down to 10°C
- Check that the red indicators located under the valve actuator are moving correctly with the signal.(Arrow on the picture)
- Fill the hydraulic system and bleed the coil using the air vents. Check incoming hot water flow rate.
- Check the various connections for possible leaks



Maximum working pressure:	8 Bars
Maximum working temperature:	110 °C

## Freeze protection

Check the hydraulic system contains glycol for protection against freezing. Glycol is the only effective protection against freezing. The antifreeze must protect the unit against freezing under winter conditions.

**Warning: glycol based fluids may produce corrosive agents when mixed with air.**

## Drain the installation

You must ensure that the manual or automatic air vents have been installed on all high points in the system. In order to drain the system, check that all the drain valves have been installed on all low points of the system.

Heating hot water coils frozen due to low ambient conditions are not covered by the warranty.

## Electrolytic corrosion

Attention is drawn to the corrosion problems resulting from electrolytic reaction created by unbalanced earth connections. Any coil damaged by electrolytic corrosion is not covered by the warranty.





## Electric heater

**WARNING: electric heater is connected heater to mains power – risk of electrical shock – switch off the unit prior to open this section**

The BALTIC™ electric heaters are stand alone options which are fitted in the heating section of the unit. As for the hot water coil or the gas burner this option slides into the heating compartment located under the supply fan.

In order to reduce the pressure drops the airflow is ducted around the shielded resistances. The resistances are made smooth stainless steel tubes with a capacity of 6W/cm<sup>2</sup>.

It is protected as standard, against overheat via a high temperature overload protection set at 98°C and located less than 150mm after the heater itself.

There are three sizes available for each size of unit:

S: Standard heat

H: High heat

The standard heat electric heaters are staged control with 50% or 100%. The high heat version is controlled through a fully modulating triac.

Module size (kW)	380V		400V		415V	
	Current (A)	Cap (kW)	Current (A)	Cap (kW)	Current (A)	Cap (kW)
12	16,3	10,8	17,0	11,8	17,8	12,8
24	32,6	21,5	34,0	23,5	35,6	25,6
27	36,7	24,3	38,3	26,6	40,1	28,8
36	48,9	32,3	51,1	35,3	53,3	38,4
45	61,1	40,5	63,8	44,3	66,8	48,0
48	65,2	43,0	68,1	47,0	71,1	51,3
54	73,4	48,4	76,6	52,9	80,0	57,7

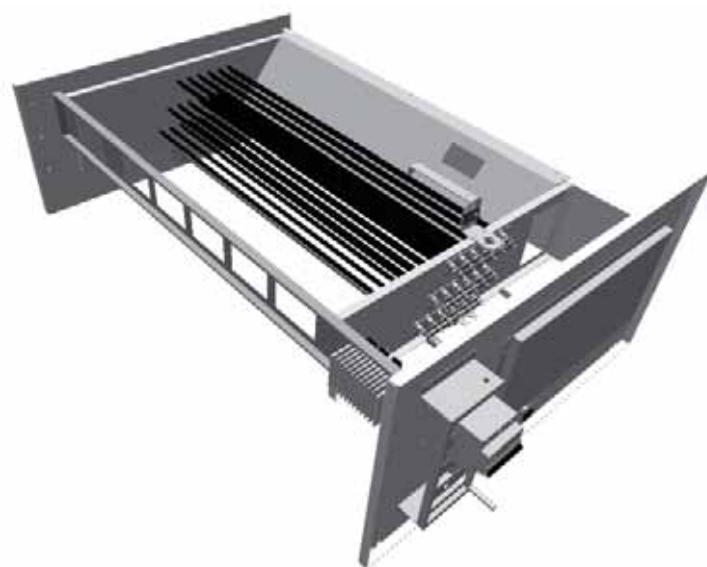

## Electrical preheater

**WARNING: electric pre-heater is connected heater to mainS power – risk of electrical Shock – switch off the unit prior to open this section**

Pre-heater is running only with high fresh air rate under low outdoor ambient temperature (see setpoint in CLIMATIC™ section).

A metallic filter is installed between air filter & electrical resistance to protect against heat radiations.

**WARNING: electric pre-heater metallic filter must not be plugged by dust**

	Amps per model size	C BOX				D BOX				E BOX	
		24	30	38	42	45	52	57	65	75	85
Size S / H	S 18 kW	26	26	26	26						
	S 24 kW					35	35	35	35		
	S 36 kW									52	52
	H 36 kW	52	52	52	52						
	H 48 kW					69	69	69	69		
	H 72 kW									104	104



**Preliminary checks before start-up**

**Note:**

Any work on the gas system must be carried out by qualified personnel.

This unit must be installed in accordance with local safety codes and regulations and can only be used in planned installation conditions for outdoor.

Please read carefully the manufacturer’s instructions before starting a unit.

Before commissioning a unit with gas burner, it is mandatory to ensure that the gas distribution system (type of gas, available pressure...) is compatible with the adjustment and settings of the unit.

**Check access and clearance around the unit**

- make sure one can move freely around the unit.
- a minimum one-meter clearance must be left in front of the burnt gas exhaust flue.
- combustion air inlet and burnt gas exhaust(s) must not be obstructed in any way.

**Supply network pipe sizing**

Male threaded connection for gas burner: 3/4"

Check that the gas supply line can provide the burners with the pressure and the gas flow rate necessary to provide the heating nominal output.

Number of male threaded connections (3/4")

Unit size	24	30	38	42	45	52	57	65	75	85
S power	1	1	1	1	1	1	1	1	1	1
H power	1	1	1	1	1	1	1	1	2	2

Gas flow - m³/h (for G20 at 20 mbar and 15°C)

Unit size	24	30	38	42	45	52	57	65	75	85
S power		1,9				3,2			5,7	
H power		4,5				5,7			11,5	

For modulating gas we have just H power for c, d & e-box

- the gas supply of a rooftop gas unit must be realized according to sound engineering practice and the local safety codes and rules.
- in any case the diameter of pipe-work connected to each rooftop must not be smaller than the diameter of the connection on the rooftop unit.
- make sure that a shut-off isolation valve has been installed before each rooftop.
- check the supply voltage to the exit of the power supply's transformer t3 of the burner: it must be between 220 and 240v.

**Starting up the gas burner**

Purge the pipe-work near the connection on the ignition control valve for a few seconds.

- check that the unit's treatment "fan" blower is running.
- set the control to "on" this will priorities the gas burner.
- increase the set temperature (room set point temperature) to a temperature higher than the actual room temperature.



### Standard start-up chronology

Time in seconds		1	2	3	4	5	6	7	8	9	10	11	29	30	31	32	33	34	35	36	37	38	39	40	41	42	43	44	45	46	398	399	400	401		
Operations	Control operation sequence	█											█																█							
	Extraction fan			█											█																█					
	Smoke extraction fan "ON"					█											█																█			
	30 to 45 seconds pre-ventilation					█											█																			
	Fire-up spark electrode 4s																																			
	Opening of the gas valve "high heat"																																			
	Flame propagation towards the ionisation probe																																			
	If ionisation within 5sec:normal running																																			
	Otherwise fault on gas ignition control block																																			
	After 5 minutes, fault reported on the CLIMATIC™ controller																																			

If incorrect sequence, refer to the fault analysis table to identify the problem.

**Pressure adjustments on Honeywell pressure regulating valve type vk 4105 g**

Pressure regulator adjustment with 300mbar gas supply:



**High heat injection pressure checks**

- place the tube of the “accurate” manometer to the out port on the gas injector support bar after having loosened the screw by one turn.

- the burner must run in high heat mode for this check.
- place the tube of the “accurate” manometer on the inlet pressure port of the gas regulating valve after having loosened the screw by one turn

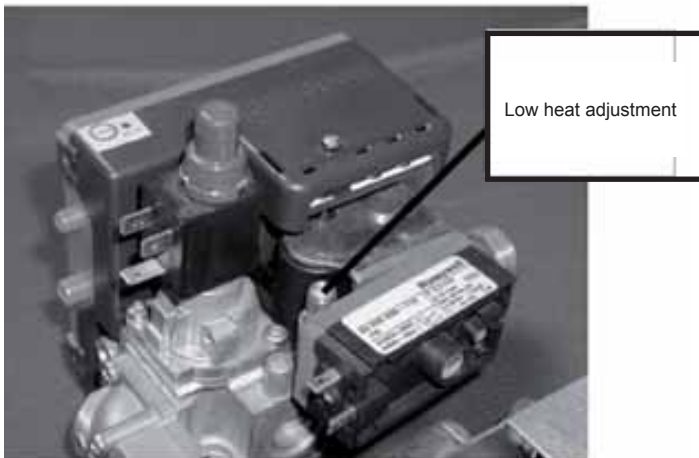

Check and adjust if necessary the valve outlet pressure to 8,4 mbar (G20) / 12,3 mbar for groningue (G25) & 31,4 mbar for propane (G31)

- Check and adjust if necessary the valve inlet pressure to 20 mbar (g20) or 25 mbar for groningue (g25) or 37 mbar for propane (g31). After gas burner ignition.

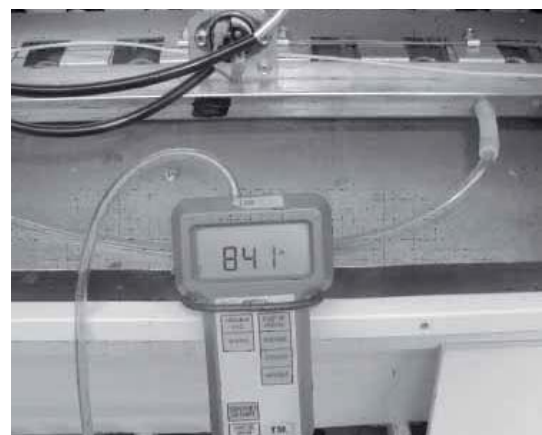

**Low heat injection pressure checks**

- switch the control to low heat
- check and adjust if necessary the outlet pressure to 3,5 mbar (G20) or 5 mbar for groningue(G25) & 14 mbar for propane (G31)



**Valve electrical control**

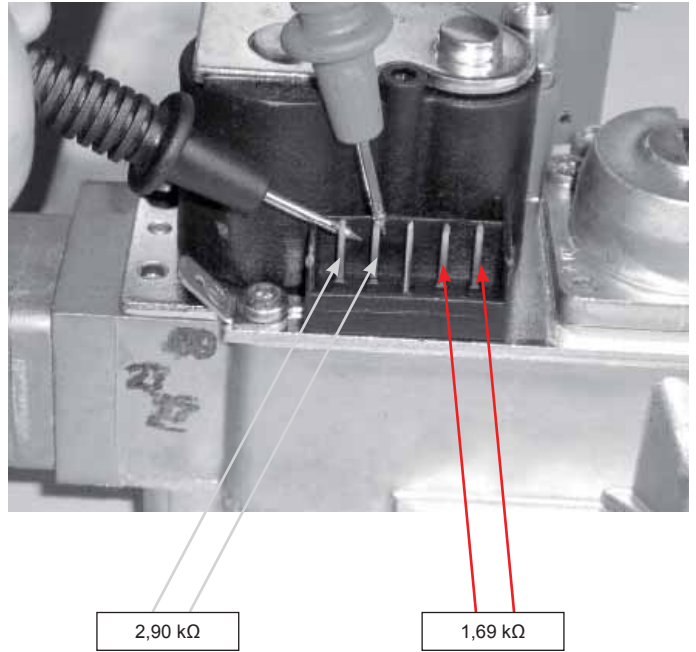

- check these values with an ohmmeter.



- after the adjustment of the low heat, re-verify the high heat
- re-position the stoppers and close the pressure ports

**Pressure adjustments table for each type of gas (mbar)**

Category	Supply pressure	Low heat injection min,	High heat injection
G20	20,0 +/- 1	3,5 +/- 0,1	8,4 +/- 0,2
G25 (groningue)	25,0 +/- 1,3	5,0 +/- 0,1	12,3 +/- 0,2
G31 (GPL)	37,0 +/- 1,9	14,0 +/- 0,3	31,4 +/- 0,6

**Burner safety checks**

**Smoke extractor pressure switch test**

- with the gas burner running, disconnect the flexible tube fitted to the pressure tapping on the pressure switch.
- the flame must disappear and the extraction fan must carry on running.
- however, no fault will be displayed (gas ignition control block or CLIMATIC™).



- after reconnecting of the tube, the burner will restart after a period of 30 to 45 seconds pre-ventilation.

**Ionisation probe test**

- with the gas burner running, disconnect the terminal plug coming from the ionisation probe to the gas ignition control box.



- the flame disappears
- the fan is still running and attempting to restart the burner (restart cycle 30 to 45 seconds).
- if the ionisation probe is not reconnected at the end of the ignition sequence the burner will stop completely.
- the fault light on the gas ignition control block is on.
- manually reset the gas ignition control block to eliminate the fault

**Gas pressure switch test**

- with the gas burner running, close the shut off valve located before the rooftop.



- the burner stops completely.
- however, no fault light will be displayed on the gas ignition control block. After 6 minutes, the CLIMATIC™ will display a fault.
- reset the CLIMATIC™.

**In case of problems refer to the start up sequence flowchart next page**

Gas burner fire-up sequence

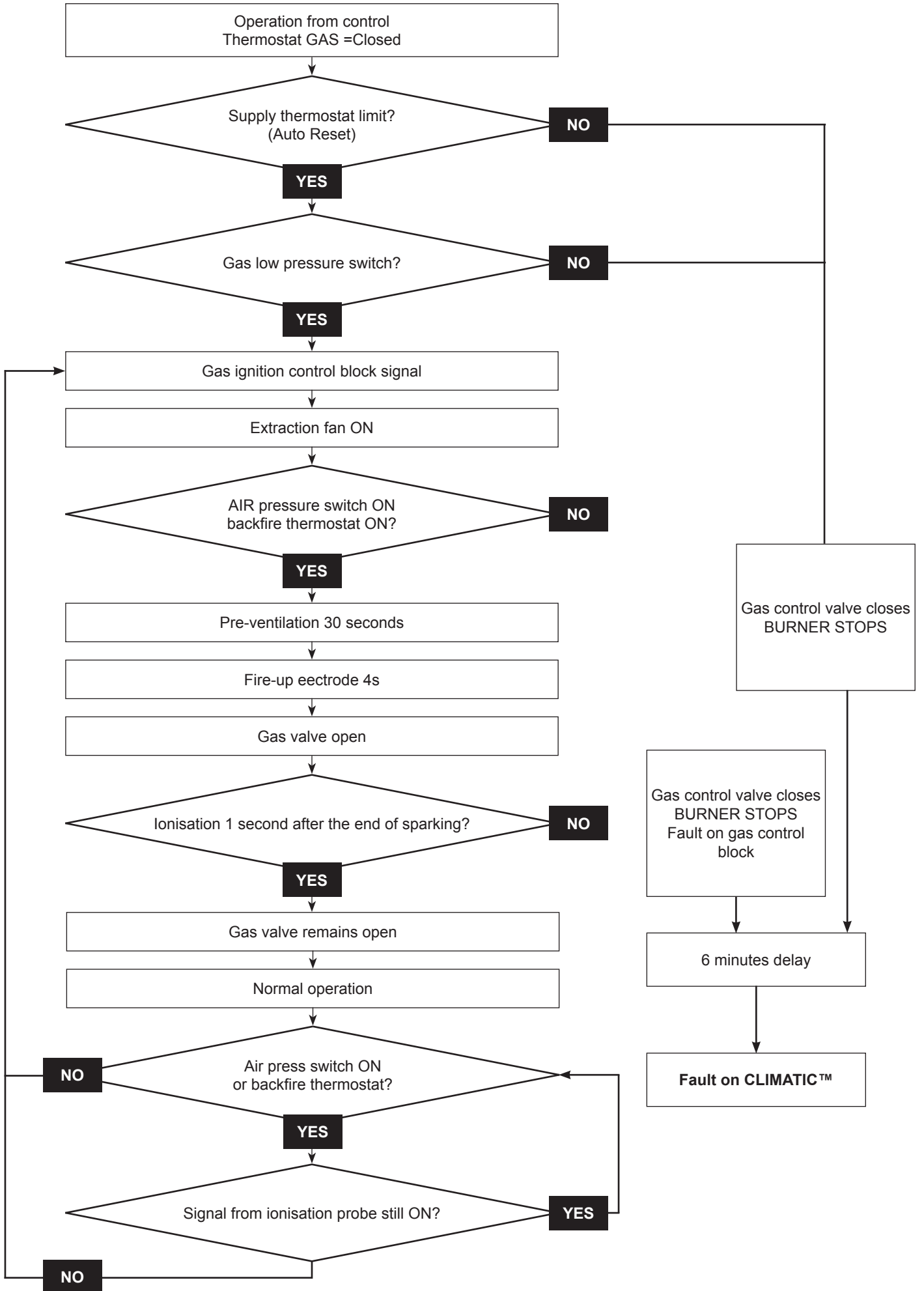



## Gas burner troubleshooting

If faults reported on CLIMATIC™

- reset the CLIMATIC™.
- check voltage: 230v after circuit breaker.
- check gas isolation shut-off valves are open.
- check gas pressure at the inlet of the gas valves. It must be >20 mbar when the burners shut down.
- adjust the set points to priorities the burner. Increase the value of the room temperature set point to a temperature higher than actual room temperature.

Diagnostic table baltic gas burner				
Stage	Normal operation	Possible fault	Action	Possible solution
Heating requested	Green, yellow & red l.e.d. ON	All l.e.d. OFF → fault on the blower thermostat	Check connections on the blower thermostat.	Replace thermostat
		Yellow & red l.e.d. OFF → lack of gas supply	Check valve's opening & supply pressure	Restore gas supply
		Red l.e.d. OFF → fault on the superheat thermostat on the gas burner support bar	Check thermostat's operation after manual reset	Replace thermostat
L.e.d on	Extraction fans are running	After 10 seconds safety shutdown by the ignition control block	Check connections of the control block on the gas valve Check impedance of electro valve's coils: (1) = 2.90kΩ; (2) = 1.69kΩ	repositioning of the control block on the valve Replace valve
		Nothing happens	Check the free movement of the fan wheel Check electrical connection on the gas ignition control block and on ef connection board Check the fan supply voltage	Replace fan Replace ef connection board if necessary
Extraction fan is on	After 30 to 45 seconds: pre-ventilation the fire-up electrode should spark.	Continuous ventilation without sparks from fire-up electrode	Check the fire-up electrode Check the pressure drop at the pressure switch: it must be higher than 165 pa +check the good operation of the pressure switch using an ohmmeter and by artificially creating a depression in the tube.	Re-position the pressure switch tube. Change the pressure switch.
Continuous ventilation and sparks from fire up electrode.	After a few seconds the gas burner fires-up	After 4 seconds the gas burner still not operating and safety shutdown by the ignition control block.	Check injection pressure during start-up (value for high heat) Remove the control box from the gas block.	Remove the air from the gas pipe-work Adjust the injection pressure to high heat value. Change the control box if the gas valve is ok.
		Within 4 seconds the gas burner fires-up but safety shutdown from the ignition control block.	Check the position and connection of the ionisation probe. It must not be earthed (230v). Check that r.c circuit of the gas burner's transformer is well connected to the neutral polarity Measure the ionisation current: it must be higher than 1.5 microamps. Check the type of gas.	Check the whole electrical supply. Adjust the supply and injection pressure if gas is different from natural gas g20 :( g25 gas of groningen for example).

**Disassembling the gas burner for maintenance purposes**

**Preliminary safety recommendations**

- isolate the unit using the main isolator switch.
- close off the isolating gas valve located before the unit.
- disconnect the pipe-work. Do not discard the seals.



**Disassembling the gas «burner support bar»**

- disconnect the electrical connector on the electric connection board BG50
- remove the two screws which hold the gas bar in place
- carefully remove the gas « burner support bar » avoiding any damages to the electrodes.



**Disassembling the flue**

- electrically disconnect the fan and remove the screws holding it in place.
- take care not to loose any cage nuts in the smoke box.

Attention: check the correct position of the pressure tube used by the extraction pressure switch.

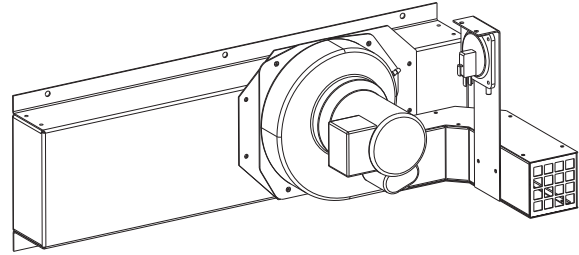

**Required equipment list for maintenance adjustment and start-up**

- an accurate manometer from 0 to 3500 pa (0 to 350 mbar): 0,1% full scale.
- a multimeter with ohmmeter and micro-amps scale
- an adjustable spanner
- tube spanner set: 8, 9, 10, and 13.
- flat screwdrivers diameter 3 and 4, fillips n°1
- vacuum cleaner
- paint brush



**Gas burner support bar**

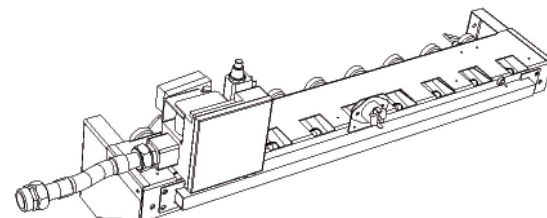

**Gas module**

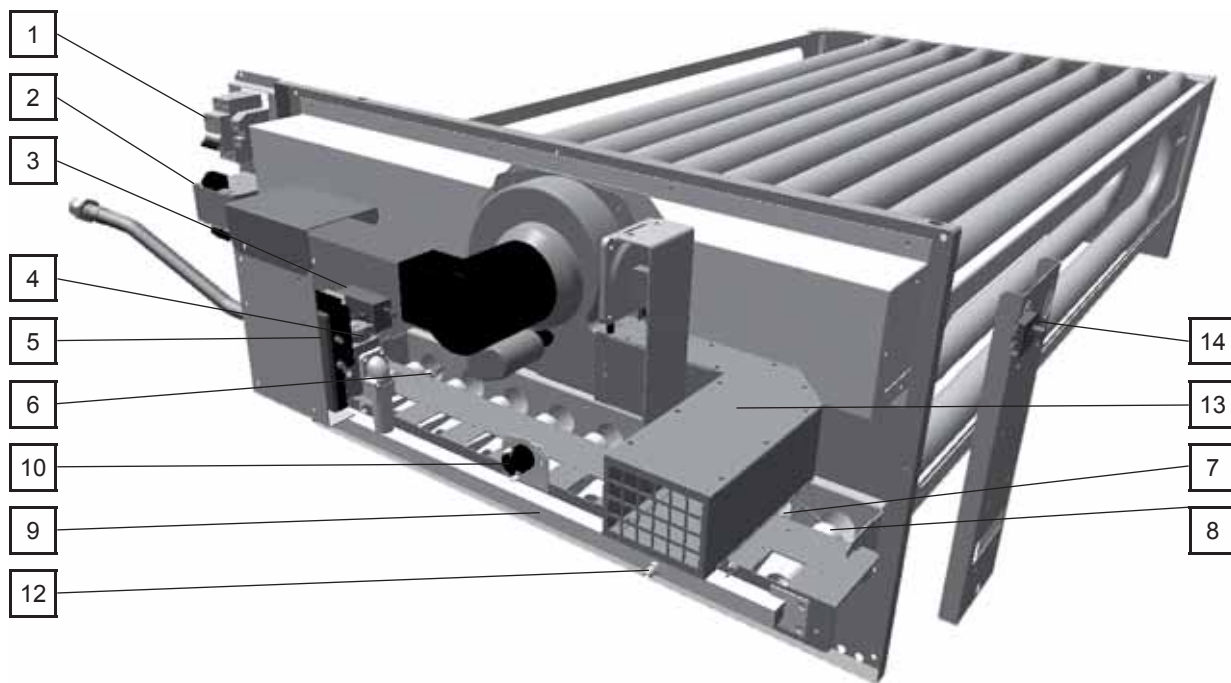

1.	Circuit breaker
2.	Transformer 400/230V
3.	Minimum gas pressure switch and inlet pressure plug
4.	Gas valve and solenoid
5.	Gas ignition control block and BG50 connection board
6.	Ignition electrode
7.	Ionisation probe
8.	Gas inshot burner
9.	Gas injectors support bar
10.	Backfire thermostat
11.	Air pressure switch
12.	Outlet pressure plug
13.	Smoke exhaust chimney
14.	Supply safety thermostat

**Modulating gas (under patent inpi mai 2004)**

**The actuator**



The actuator receives an information 0-10v from the regulation for the positioning of the air shutter; then the actuator transmits its position to the printed-board which will order the valve.

**Check position and operation of the actuator**

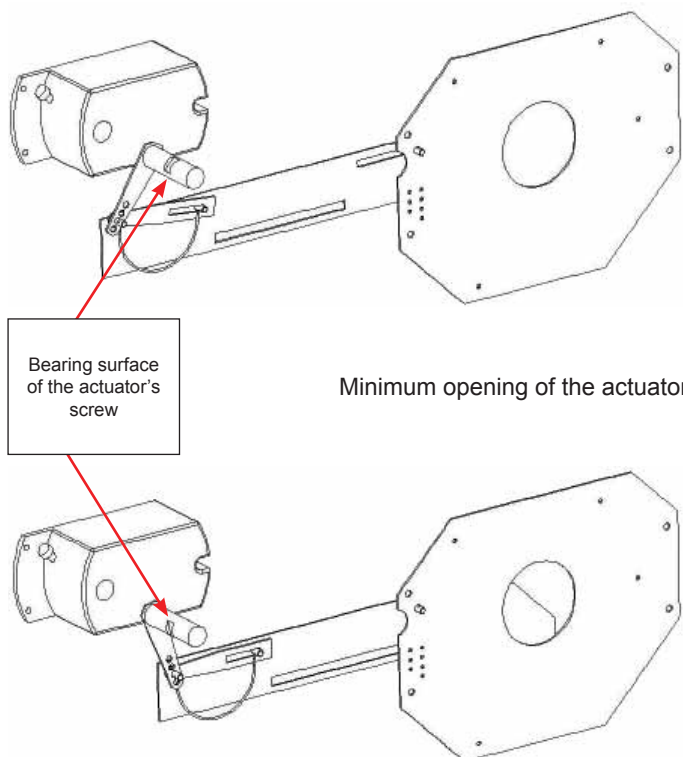

**Starting up the gas burner**

Purge the pipe-work near the connection on the ignition control valve for a few seconds.



- check that the unit's treatment fan blower is running.
- set the control to "on" this will priorities the gas burner.
- increase the set temperature (room set point temperature) to a temperature higher than the actual room temperature.

The start of the gas burner must be done at **high heat injection**.

**Pressure adjustments on honeywell pressure regulating valve type vk 4105 g**

Pressure regulator adjustment with 300 mbar gas supply:



**High heat injection pressure checks**

- place the tube of the “accurate” manometer to the out port on the gas injector support bar after having loosened the screw by one turn.

- the burner must run in high heat mode for this check.
- place the tube of the “accurate” manometer on the inlet pressure port of the gas regulating valve after having loosened the screw by one turn

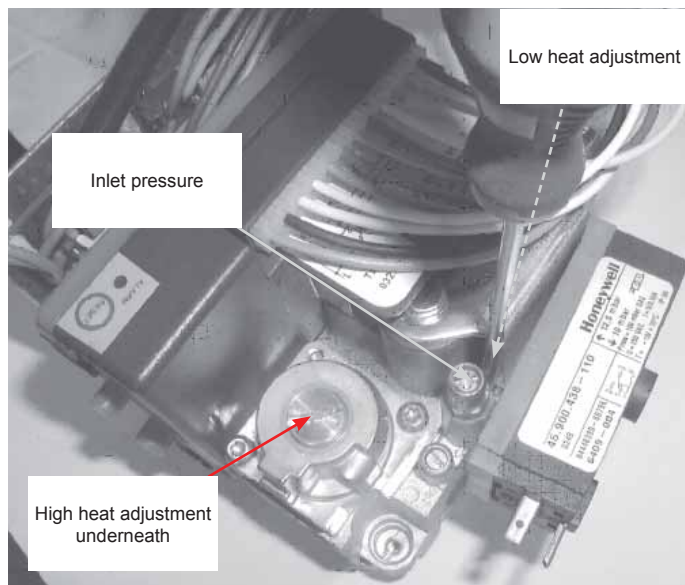
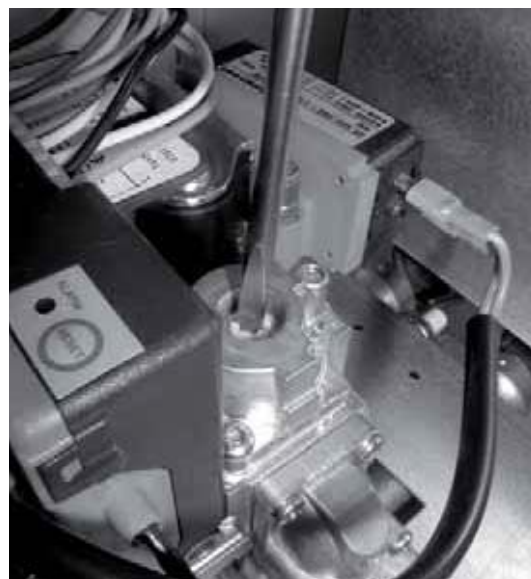

Check and adjust if necessary the valve outlet pressure to 8,4 mbar (G20) (or 12,3 mbar for G25)

- Check and adjust if necessary the valve inlet pressure to 20 mbar (G20) (or 25 mbar for G25) after gas burner ignition

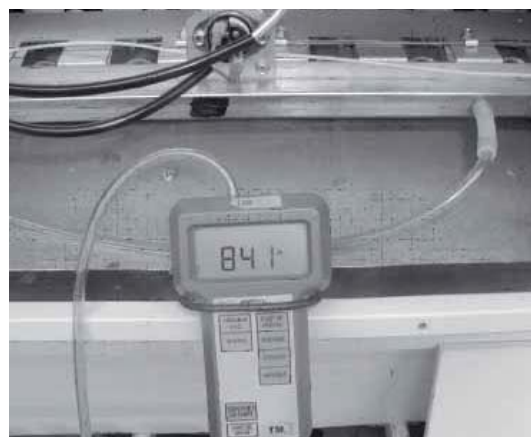

**Low heat injection pressure checks**

- switch the control to low heat
- check and adjust if necessary the outlet pressure to 1,5 mbar minimum (G20) (or 2.25 mbar for G25)
- after the adjustment of the low heat, re-verify the high heat
- re-position the stoppers and close the pressure ports.



**Pressure adjustments table for each type of gas (mbar)**

Category	Supply pressure	Low heat injection mini.	High heat injection
G20	20,0 +/- 1	1,5 +/- 0,03	8,4 +/- 0,2
G25	25,0 +/- 1,3	2,25 +/- 0,05	12,3 +/- 0,2
G31	NA	NA	NA

**Valve electrical control**

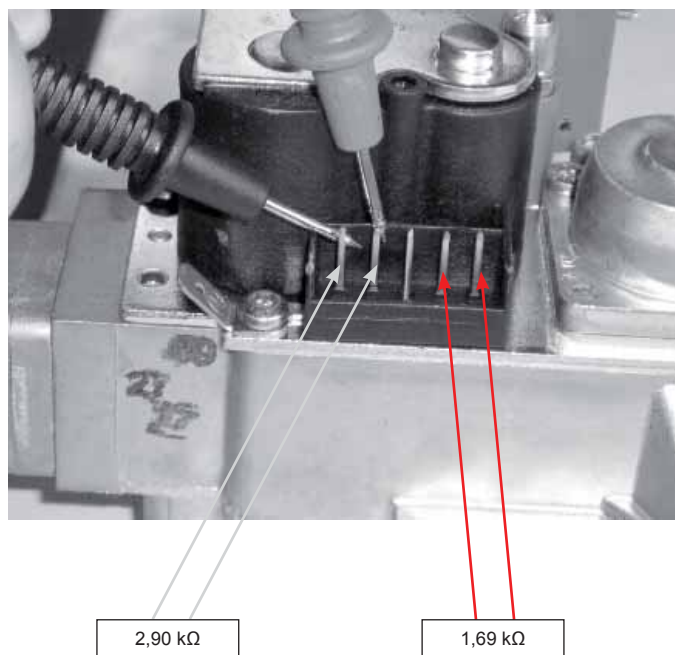

- check these values with an ohmmeter.

- after the adjustment of the low heat, re-verify the high heat
- re-position the stoppers and close the pressure ports.

**Burner safety checks**

Idem non-modulating gas burner

**Gas burner troubleshooting**

Idem non-modulating gas burner. If the valve's flow is not correct, check the operation of the actuator and of the mechanical assembly.  
 → Replace the actuator if necessary

**Disassembling of gas burner for maintenance purposes**

Idem non-modulating gas burner

**Modulating gas**

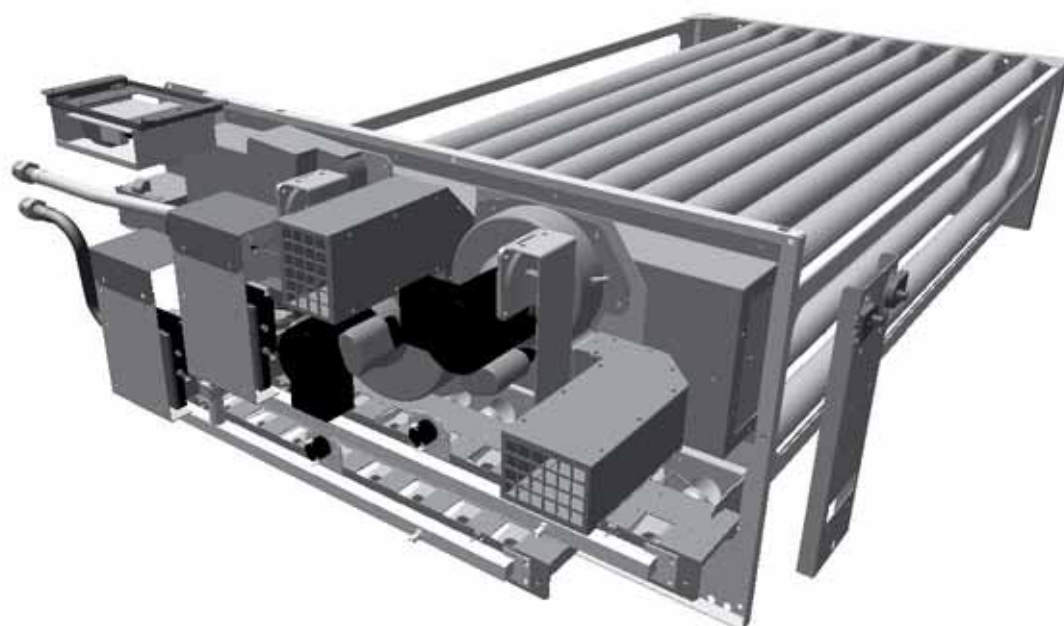

Heat recovery water coil is delivered with a loose 3 ways valve inside carton to be assembled on site by installer.



The freeze protection is made via fresh damper safeties nevertheless for a full freezing protection has to be done using glycoled water

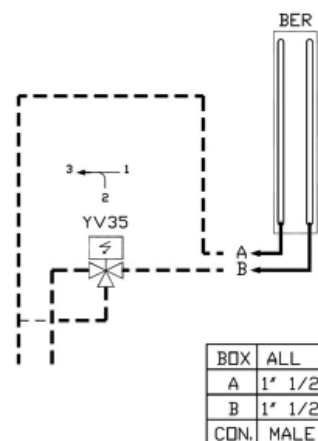



## Refrigeration

Fault	Possible cause and symptoms	Solution
LP problems and LP cut outs	Refrigerant charge too low	Measure the superheat and sub-cooling: Good if $5^{\circ}\text{C} < \text{sc} < 10^{\circ}\text{C}$ and $5^{\circ}\text{C} < \text{sh} < 10^{\circ}\text{C}$ Bad if $\text{sc} > 10^{\circ}\text{C}$ and sh too low Check superheat adjustment and charge unit (a leak check must be carried out)
	In heat pump mode the temperature difference between t outdoor and tevap. (dew) is too high $5^{\circ}\text{C} < \Delta t < 10^{\circ}\text{C}$ excellent $10^{\circ}\text{C} < \Delta t < 15^{\circ}\text{C}$ acceptable $15^{\circ}\text{C} < \Delta t < 25^{\circ}\text{C}$ too high	If too high check the coils are clean or check coil internal pressure drop between the liquid line and the suction line Good if $< 3\text{bar}$ Too high if $> 3\text{bar}$ (coil blocked)
	Refrigeration circuit blocked in distribution	Stop the fan and create icing of the coil. Check all circuits freeze evenly across the whole surface of the coil If some parts of the coil do not freeze this could indicate a problem with the distribution
	Liquid line drier blocked. High temperature difference between inlet and outlet of the drier	Change filter drier
	Contaminant in the expansion valve	Attempt to free the valve adjusting element by freezing the valve and then heating the thermostatic element. Replace the valve if necessary
	Expansion valve not adjusted properly	Adjust the expansion valve
	Ice plug in the expansion valve.	Heat the main body of the valve. If the LP increases and then decreases gradually, empty the circuit and replace the drier.
	Incorrect insulation of the thermostatic bulb of the expansion valve	Superheat too low: adjust superheat Move the thermostatic element along the pipe Insulate the thermostatic element of the valve
	Low pressure switch cut out point too high	Check the cut out pressure of the low pressure switch: it must be $0,7 \pm 0,2\text{bar}$ and must close at $2,24 \pm 0,2\text{bar}$
	LP cut out due to not enough defrost on heat pumps	Adjust the CLIMATIC™ settings to extend the defrost cycles or shorten the time between defrosts
HP problems and HP cut outs	Incorrect airflow rates	Heat pump mode: check the filter before the indoor coil measure and estimate the airflow rate increase the speed of the fan Cooling mode: check the condenser fan (amps)
	Moisture or contaminants in the system	Summer operation Several hours after the unit has stopped, check the correspondence between the measured pressure and the outdoor temperature

## Refrigeration (cont'd)

Fault	Possible cause and symptoms	Solution
HP problems and HP cut outs	Moisture or contaminants in the system	If the circuit pressure is higher (<1 bar) than the saturated pressure corresponding to the measured outdoor temperature, there is possibility that some contaminants are present in the system. Reclaim the refrigerant, and vacuum the circuit (ensure very low and slow vacuum for R410A) Recharge the unit
	Condenser coil is obstructed	Check the condenser coil and clean is necessary
	Recycled hot air	Check clearance around the condenser
Strong variations of pressure ( 2 to 3 bar) expansion valve "hunting"	Incorrect adjustment of the expansion valve Low refrigerant charge Filter drier obstructed with gas bubbles at the expansion valve inlet Moisture in the system	Refer to LP problems and LP cut out section
Very high discharge temperature, High amps measured at compressor	Very high superheat, very hot compressor	Reduce the superheat on the electronic valve. Check the pressure drop on the filter drier in the suction line
	Four way reversing valve possibly blocked, abnormal noise from the valve, low LP and increasing HP	Check operation of the valve by going through cycle inversions. Change if necessary. Refer to LP problems

## Indoor fan blower

Fault	Possible cause and symptoms	Solution
High amps on action fan motor	Pressure drop in the ducting installation too low.	Reduce the rotation speed of the fan Read the airflow and pressure and compare with the specification from customer.
High amps on reaction fan motor	Pressure drop in the ducting installation too high.	Reduce the rotation speed of the fan Read the airflow and pressure and compare with the specification from customer.
Unstable running and high vibration	Fan jumping from one operating point to the other	Change rotation speed of the fan.

## Outdoor axial fan

Fault	Possible cause and symptoms	Solution
Heat pump mode: circuit breaker open	High amps due to a low voltage from the main supply	Check the voltage drop when all components are running. Change the circuit breaker for one with a higher rating.
	High amps due to freezing of the coil	Check the adjustable amps on the motor starter. Adjust the defrost cycle set points.
	FLEXY™: water ingress in the motor connection box.	Change the component

## Electric heater

Fault	Possible cause and symptoms	Solution
High temperature trip out on electric heater	Low airflow rate	Measure and estimate the airflow and pressure and compare with the specification from customer.
	Incorrect position of the klixon	Check that the klixon, is positioned in the airflow, relocate klixon if necessary Check that there is no heat transfer from the klixon support.

## Water leaks

Fault	Possible cause and symptoms	Solution
Water found in the ventilation section	Cooling mode: water carried away from the coil because of excessive airflow and speed on the coil.	Estimate the airflow rate and check the speed is lower than 2,8 m/s
	Low air pressure in the compartment due to a high airflow rate or a high pressure drop before the fan	Check filter Reduce airflow rate
	Check seals around the ventilation section.	Check the door seal Check for the presence of silicone seals in the corners of the door and at the bottom of the refrigeration section bulkhead.
Water ingress in the filter compartment	Water ingress through a leaking fresh air hood or when running 100% fresh air	Check the seals and flanges in the fresh air hood Reduce the airflow rate if necessary

## CLIMATIC™ Displays

Fault	Possible cause and symptoms	Solution
Nothing is written on the screen but it's enlightened	Idem	Press on the three right-hand side's buttons at the same time during a few seconds then reconfigure display address setting at 32.
Nothing occurs on the unit or an option disappeared	Possible problem of units' configuration	Check the instructions from 3811 to 3833 and reconfigure options if necessary.
The message "no link" appears	Problem of addresses' recognition	Disconnect the DS from the unit and then reconnect it.
All the units are extinct	Problem main board plan addressing	Disconnect then re-plug; disconnect each unit from the others then change all the plan addresses

Refrigeration components R410A	Designation	Family	Code
Compressor	ABA054WAA	Comp	4220463P
	ARA073WAA	Comp	4220464R
	ARA081WAA	Comp	4220465T
INDOOR coil	ID Cbox size 24-30	Coil	4310501Y
	ID Cbox size 38-42	Coil	4310488F
	ID Dbox	Coil	4310490J
	ID Ebox	Coil	4310491K
OUTDOOR coil	OD CDbox 2 rows size 24-30 -45-52	Coil	4310499W
	OD CDbox 3 rows size 38-42-57-65	Coil	4310489H
	OD ELeft	Coil	4310492L
	OD Eright	Coil	4310493M
Expansion valve	Electronic expansion valve E2V30	Refrig	4720927R
	E2V45	Refrig	4720928T
	Electronic expansion valve cable 3M	Refrig	4720931X
Filter Drier	DMB165S	Refrig	4720905K
	DML165S	Refrig	4720907M
Non return valve	NRV16S	Refrig	4720002H
4 way valve	STF0715	Refrig	4740101N
4 way valve coil	24V 50	Refrig	4740103R
Pressure switch	HP 42.0 bars OFF 2X faston	Refrig	4730184H
	Pressure sensor. ratio BP fréon 1 à 45 bar EMBASE DIN	Control	4730185H
	Pressure sensor.4/20 HP fréon 1 à 45 bar EMBASE DIN	Control	4770207M
	Valve body 1/4 flare	Refrig	5660010W
	Valve body 5/16"	Refrig	5660226N
	Valve mecanism	Refrig	5660012Y
	Valve Cap 5/16"	Refrig	5660228R
Flexible inox	Flex ble INOX 5/8" DN15 600mm	Hoses	4681022J
	Flex ble INOX 1"1/8" DN25 800mm	Hoses	4681030V
Copper Tees	7/8" - 1"1/8 - 7/8" - F ODS	Piping	5650174H
Copper 2 en 1	5/8" - 5/8" - 7/8" - F ODS	Piping	5320508 E

Casing	Designation	Family	Code	
Economiser	Fresh air hood grille C box	Sheet metal	4921101P	
	Fresh air hood grille D box		4921102R	
	Fresh air hood grille E box		4921103T	
Insulation	Rockwool	Insulation	5840166H	
	isolene foam M1		5840071R	
Door sealing gasket	15 x 15	Gaskets	5680259Y	
Lock 1/4 T	1000-U188-N2+18+990	Fixings	5880190P	
	1000-U155D		5880164A	
Handle door	1091-103-02		5880109W	
Handle outdoor coil	M443/140N		5880160W	
Charnieres clips	8576178 SNAP LINE		5880187L	
Sealant	0933015118 REF 933		Gaskets	5680251M

Electrical & control components	Designation	Family	Code
CLIMATIC™	BM060 small	Control	4770701N
	BM060 medium		4770702P
	Connector for BM60 small		4770707X
	Connector for BM60 medium		4770708Y
Sensors	Ntc -50+105 7 metres		4770721T
	Ntc -50+105 3 metres		4770720R
Ambient sensors	Ambient sensor		4770613K
Pressure sensor	Analog filter sensor		4730097A
Fan inverter	Inverter21 0.75 kW	Inverter	4780468A
	Inverter21 1.5 KW		4780469E
	Inverter21 2.2 kW		4780417A
	Inverter21 3 kW		4780470F
	Inverter21 4 kW		4780418E
	Inverter21 5 kW		4780425N
	Inverter21 7.5 kW		4780419F
	Inverter21 9-11 kW		4780421J

Outdoor fans	Designation	Family	Code
Vent cond C-D BOX small	FL063	Axial fan	4921095H
Vent cond C-D BOX big	FN071		4921096J
Vent cond E BOX	FN080		4921097K

Ventilation & Filtration components	Designation	Family	Code
Filtration	500x530x50 G3	Filters	4960128J
Filter G4 metal frame	500x530x50		4960129K
Filter G4 rechargeable	500x530x50		4960134R
Filter F7	500x530x100		4960130L
Actuator	NM 24SR + connection	Damper	4781286T
Indoor fan	AT15-11S	Supply fan	4910018R
	ADHE 355		4910090X
	AT 15-11 G2L D30		4910080H
	AT 15-11 G2L D40		4910094E
Motor	1,5 kW	Motor	4520102L
	2,2 kW		4520106R
	3 kW		4520107T
	4 kW		4520108V
	5,5 kW		4520109W
	7,5 kW		4520111Y
	9 kW		4520113A
	11 kW		
Coupling	PNEUMABLOC PV40 H	Motor	4950761J
	PNEUMABLOC PV50 H		4950762K
	PNEUMABLOC PV60 H		4950763L
	PNEUMABLOC PP50 ALÉS.38		4950768T
	PNEUMABLOC P40		4950764M
	PNEUMABLOC P50		4950765N
	PNEUMABLOC P60		4950766P
	Cast Bush 40-25 alésage 40		4950769V
	Cast Bush 28-20 alésage 25		4950035P
	Cast Bush 28-20 alésage 24		4950040X
	Cast Bush 40-25 alésage 38		4950046H
	Cast Bush 28-20 alésage 28		4950050M
	Cast Bush 30-25 alésage 25		4950053R
	Cast Bush 30-25 alésage 28		4950054T
Cast Bush 30-25 alésage 30	4950238N		
Elastic grummet fans	M6x30		5680408T
Earth connection	M6x30	Supply fan	5480956H

Miscellaneous	Designation	Family	Code
siphon	Tube ep 5 mm noir	Fixings	4680360K
Key	Double index	Fixings	5880158T

## Terms and conditions

In the absence of any other written agreement, the guarantee shall only apply to design faults which occur within a 12 month period (warranty period).

The warranty period starts on the date of commissioning and at the latest six months after the delivery of the Rooftop.

## Anti-corrosion warranty

### 10 year warranty terms and conditions for corrosion to the Rooftop casing:

LENNOX shall guarantee the casing of its Rooftop units manufactured since May 1991 against corrosion for 10 years commencing from the date of delivery of the material.

The warranty shall not apply in the following cases:

1. If the corrosion of the casing is caused by external damage to the protective layer such as scratches, projections, abrasion, impacts etc...
2. If the casing is not kept continually clean in the course of maintenance work or by a specialist company,
3. If the casing is not cleaned and maintained in accordance with regulations,
4. If the Rooftop units are installed on a site or in an environment which is known to be corrosive, unless a special protective coating has been applied by the owner for these applications, which has been recommended by a competent body not linked to the owner and after carrying out a study of the site.
5. Nevertheless the LENNOX coating is highly resistant to corrosion, the warranty will not be applied for rooftop installed at less than 1000 m away from the sea

Note: With the exception of the casing, the rest of the machine is covered by the warranty of our general terms of sale.

## Do not confuse the warranty with maintenance

The warranty will only apply if a maintenance contract has been signed, starting from the date of commissioning, and if the maintenance contract has actually been performed

The maintenance contract must be made with a specialist, competent company.

The sole effect of any repair, modification or replacement of an item during the warranty period must be to extend the material's warranty period.

Maintenance must be carried out in accordance with regulations.

If a spare part is supplied after the expiry of the warranty period, it shall be guaranteed for a period equal to the initial warranty period and will be subject to the same conditions.

We recommend for a contract four inspections per year (every three months), before the start of each season, in order to check the operation of the equipment in the various operating modes.

Rooftops are generally placed on the roof but can also be installed in technical rooms. These units are very robust but a minimum regular maintenance is required. Some moving parts in the units can suffer from wear and tear and must be checked regularly (belts). Other parts can get clogged by dirt carried in the air (filters) and must be cleaned or replaced.

These units are designed to produce cooled or heated air through the use of a refrigeration vapour compression system, it is therefore imperative to monitor the refrigeration circuit operating pressures and check the pipe-work for leaks.

The table below, details a possible maintenance plan, including the operations to be carried out and the periodicity at which they must be accomplished. It is recommended to follow such a plan to keep a rooftop unit in good working order. Regular maintenance of your rooftop will extend its operating life and reduce operating faults

Symbols and Legend :

- X      Operation which can be carried out by on-site maintenance technicians.
- Operation which must be carried out by qualified refrigeration personnel, trained to operate on this type of equipment.

Note:

- Times are given for information purpose only and may vary depending on the unit size and type of installation.
- Coil cleaning must be carried out by qualified personnel using appropriate methods that won't damage the fins or the tubes.
- It is recommended to keep a minimum stock of common replacement parts in order to be able to carry out regular maintenance operations (i.e. filters). You can contact your local LENNOX representative which can assist you in establishing a parts list for each type of equipment.
- The access ports to the refrigeration circuits **MUST** be leak checked every time gauges are connected to the service ports.



Task	Operating mode	Monthly	Quarterly	6 monthly	Yearly before winter	Estimated time (min)
Clean or replace filters: Disposable, or metal frame.	Replace filters with new ones if disposable. Vacuum clean or blow the dirt. Wash and dry carefully. Replace media if necessary Blocked filter will reduce the performance of the unit. THE UNIT MUST NOT OPERATE WITHOUT FILTERS	o				20
Visual check of the oil level	Visually check the oil level through the sight glass on the side of the compressor casing	o				2
Centrifugal fan bearings check	Isolate unit from the main power supply; Push the fan wheel manually and check for abnormal noises. Bearings are lubricated for life but may need replacement after 10000 hours	o				10
Check absorbed Amps	Check absorbed Amps on all three phases; compare with the nominal value given in the electrical wiring diagram.		□			15
Check Smoke detector	Start the unit. Trigger the smoke detector by moving a magnet around the detector head. Reset unit and control.		□			5
Check CLIMATIC™ control, set-points and variables	Refer to the commissioning sheet; Check all set points are set according to this document.		□			15
Check clock settings	Check the time and date of the control		o			5
Check the position and tightness of refrigeration components	Check systematically all connections and fixings on the refrigeration circuit. Check for oil traces, eventually a leak test should be conducted. Check operating pressures correspond to the ones indicated on the commissioning sheet		□			30
eDrive™ elastomeric tire status	Check the tire status. Replace weared tire if necessary.			o		10
Check Airflow rate safety switch (if fitted).	Shut down supply fan. The fault must be detected within 5 seconds.			o		
Check freeze protection on HWC				□		5

Task	Operating mode	Monthly	Quarterly	6 monthly	Yearly before winter	Estimated time (min)
Check three way valve on HWC	Increase room set-point 10°C above the actual room temperature. Check operation of the piston. It must move away from the valve head. Reset the control.			☐		5
Check economiser actuator operation	Check all fixings and transmission. Stop the unit using the control. The fresh air damper must close. Start the unit the fresh air damper should open			☐		5
Check refrigeration 4way valve	With the unit running in cooling mode increase the room set-point temperature by 10°C. The unit should switch to heat pump mode. Reset the control.			☐		5
Check tightness of all electrical connections	Power down the unit and check and tighten all screws, terminal and electric connections, taking a particular attention to the power lines and low voltage control wires			o		30
Check HP / LP safety switches	Install manifold gauges on the circuit to be checked. Shut down the axial fans and wait for the HP switch to shut down the compressor: 29 bar (+1 / -0) auto-reset 22 bar (+ - 0,7) Reconnect fans. Switch off the centrifugal supply fan and wait for the LP switch to cut out: 0.5bar (+ - 0,5) reset 1,5bar (+-0,5).			☐		15
Check HP analogic sensor calibration	Install calibrated manifold gauges on the circuit to be checked.				o	30
Check outdoor fans and fan guards	Check the fan blades conditions and all fan guards and protections				o	5
Check position of all sensors	Check the good positioning and operation of all sensors of all sensors. Check the values given in the control system. Replace sensor if necessary				o	5
Check and clean if necessary all fresh air grilles	Check the fresh air grilles (if fitted). If dirty or damaged, remove them from unit and clean with high pressure water cleaner. Refit on unit once clean and dry.				o	5
Clean condensate drain, indoor and outdoor coils (following local regulations)	Visually check the coils for dirt. If not too dirty, cleaning with a light brush may be enough (WARNING: Fins and copper tubes are very fragile! Any damage WILL reduce the performances of the unit). If very dirty, deep industrial cleaning is required using de-greasing agents. (External contractors must be called).				o / ☐	1h if cleaning

Task	Operating mode	Monthly	Quarterly	6 monthly	Yearly before winter	Estimated time (min)
Check electric heater element for excessive corrosion	Isolate the unit; Pull the electric heater out of the heater module box and check the resistances of traces of corrosion; Replace resistance as required;				o	1h if replacement
Check anti-vibration mountings, for wear and tear.	Visually check anti-vibration mountings on compressors and centrifugal fan. Replace if damaged.				o	1h if replacement
Check refrigeration circuit for traces of acid in the oil	Take a sample of oil from the refrigeration circuit.				□	
Check Glycol concentration in the HWC circuit	Check the glycol concentration in the pressurised water circuit. ( a concentration of 30% gives a protection down to aprox. -15°C) check the circuit pressure				□	30
Check defrost cycle with 4-way valve inversion.	Switch the unit to heat pump mode. Change the set point to obtain the standard defrost mode and reduce the cycle time to the min value. Check the operation of the defrost cycle.				□	30
Gas burner module check for corrosion	Pull out the burner to access the tubes (refer to Gas burner section in the IOM)				□	30
Sweeping and cleaning the gas burner	Clean the in-shot burners and the blower wheel lightly with a brush. Sweep the flue and flue box. Wipe-off the dust from the housing of the motor. Clean combustion air inlet louvers Pull-out baffles from the tubes, sweep the tubes CHECK FLUE BOX GASKET				□	30
Gas supply pressures / connections checks	Refer to Gas burner section in the IOM for details				□	15
Gas regulation valve settings	Refer to Gas burner section in the IOM for details				□	30
Check gas burner safety switches	Refer to Gas burner section in the IOM for details				□	30
Check gas fume combustion levels	Refer to local regulation				□	10



# BALTIC™

# CONTROL MANUAL

Ref : BALTIC\_Control-IOM-0412-E

## DISPLAY DC60

INSTALLATION	74
CONNECTION	74
IMPORTANT WARNING	75
ONE 'DC60' FOR ONE, AND ONLY ONE, ROOFTOP	76
TEMPERATURE MEASUREMENT	76
RELATIVE HUMIDITY MEASUREMENT	76
CONFIGURATION	77
INITIALIZATION	78
PRESENTATION	78
USE	
q On/Off unit	79
⌚ Setting time	79
ⓘ Information available	79
DC60 set in light mode	80
DC60 set in full mode	80
⊖ Setting value	81
LEVEL 2 ACTIVATION	82

## DISPLAY DM60

INSTALLATION	83
CONNECTION ON THE DT50 SPLITTER	84
DM60 AND COMMUNICATION MASTER/SLAVES	85
CONFIGURATION	86
FUNCTIONALITY OF THE DM60	86

The display DC60 is personalized for the user. It allows an overview of operation of the unit and allows access to certain parameters.

The DC60 is designed to be remote connected of the rooftop.

The DC60 is equipped with a temperature sensor.

The temperature sensor allows the acquisition of room temperature to control.

## INSTALLATION

The DC60 has been designed for flush mount assembly, on distribution boxes compliant with the standards in force.

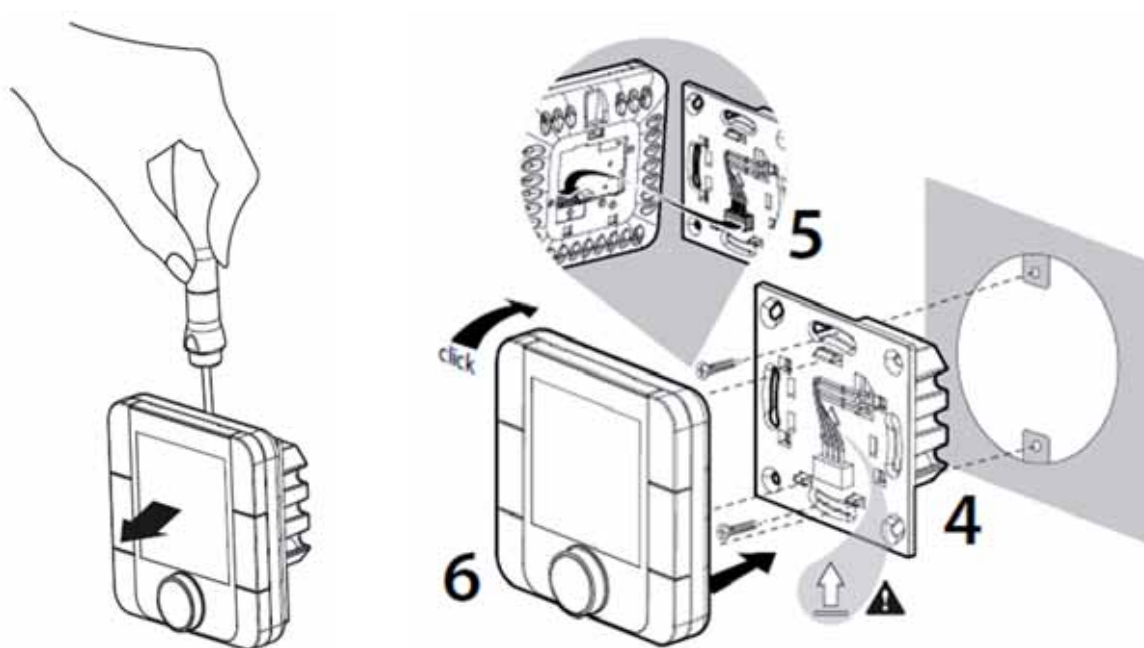

## CONNECTION

**WARNING:** Separate as much as possible probes, displays, logical input cables from power cables with strong inductive load, in order to avoid possible electromagnetic perturbations.

**IMPORTANT WARNING:** Any wiring modification on the CLIMATIC™ 60 must be done by LENNOX technician or employees having valid electrical qualification and authorization.

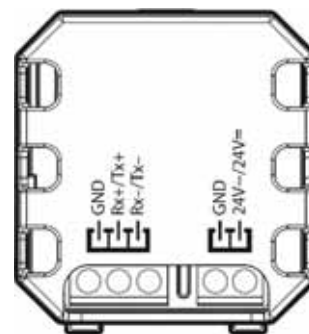

**Power supply**

The power of the DC60 can be 24Vac (+10...-15%) 50/60Hz or 24Vdc (22...35Vdc), maximum current of 2VA.

LENNOX recommends a 24Vac supply (provided by rooftop) for installation of the display less within 30 meters of rooftop. For connection of the display of over 30 meters, a power supply, close to the display, 24Vac must be provided by the installer.

For an external connection to the rooftop (24V) using a transformer class 2 under 0,1A.

**For any modification of wiring on the 24V supply or on 4-20mA sensor, check the polarity prior to apply the power. Wrong polarity may cause serious damage and destroy the Plan network. LENNOX will not accept liability for damage caused by wrong power connection or any wiring modification done by people without valid training and qualifications.**

**Communication**

The DC60 is controlled by a communication bus: RS485.

**Cable features**

The connection of power and communication must be made by the following cable:

- LiYCY-P (0.34 mm<sup>2</sup>), 2 pairs with general shield

The cable length, with power, should not exceed 30m.

The cable length without power (24V external) must not exceed 150m.

For a better electromagnetic protection, Lennox recommends the use of LiYCY-P cable

For extended networks fit a 120 Ohm resistor between RX/TX+ and RX/TX- on the first and last device, to avoid possible communication problems.

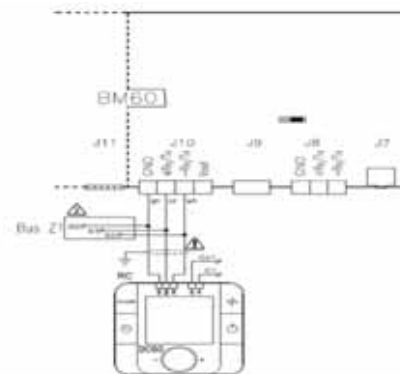

## ONE 'DC60' FOR ONE, AND ONLY ONE, ROOFTOP

The DC60 displays only the values and information of the 'Roof-Top' on which the DC60 is connected.

### TEMPERATURE MEASUREMENT

All LENNOX rooftop comes with a temperature sensor; it must be placed in the conditioned area.

But if the DC60 is placed in the area conditioned by the rooftop, that display is connected, it is possible, in this case, to use the temperature measurement of the DC60.

To indicate the CLIMATIC™ 60 your choice, set the point 3213:

- '128' to use the measure of the 'DC60'
- '1 BM-B12' or '2 BM-B1' to use the remote probe

Note :

- for rooftop with a 'medium' CLIMATIC™ 60: connect the remote sensor between points B12 and GND, terminal block J18.
- for rooftop with a 'small' CLIMATIC™ 60: by default the CLIMATIC™ 60 control the return temperature measurement. If you want to control on a room temperature measure, disconnect the return probe between points B1 and GND, terminal block J13. Connect the remote sensor in place.

### RELATIVE HUMIDITY MEASUREMENT

If the rooftop is designed to manage humidity, a box of combined sensors (temperature and humidity), supplied with the rooftop, it must be placed in the conditioned area.



It's possible to use the temperature measurement DC60.



## CONFIGURATION

To communicate with the CLIMATIC™ 60 this basic parameters of internal DC60 must to be settled.

### Setup menu

To do this, when the 'DC60 is powered; Simultaneously press the keys  and .

After some seconds, the text `C o d E` appears and the value '000' flashes.

Turn the knob  to change the value to select the number 022. Then validate the code by pressing the knob.

If the code is wrong access the setup menu is not possible and the DC60 returns to the previous  
If the code is correct the display shows `A d d r`.



(2 buttons on the right simultaneously)





### Parameter's choice

By rotating of the knob , you can view and modify the following parameters:

- `A d d r` : Address DC60 on the communication bus (Always set to value 31)
- `b A u d` : Communication speed (always set to value 2)
- `b L b E` : Backlight mode
- `b L I n` : Backlight intensity
- `P C A L` : Probe calibration
- `C n S t` : Screen contrast
- `b u d` : Disabling 'Bip' keys
- `P S u 1` : Password (always set to value 22)
- `Y E a r` : Real time clock DC60; year
- `M o n t` : Real time clock DC60; month
- `n d a y` : Real time clock DC60; day
- `u d a y` : Real time clock DC60; weekday (1 = Monday)
- `H o u r` : Real time clock DC60; hour
- `m i n S` : Real time clock DC60; minute
- `E S C` : Exits the settings mode

### Changing the parameters value

To activate the modified mode value:

- After selecting the desired parameter by rotating the knob .
- Press the knob .
- The `S e t` symbol appears on the right side of the value.
- Turn the knob  to adjust the desired value.
- Press again on the knob  to confirm your choice.
- The `S e t` symbol is no longer displayed on the right side of the value.
- The rotation of the knob  is for select a new setting.

### Mandatory values

- `A d d r` : 31
- `b A u d` : 2
- `P S u 1` : 22

## INITIALIZATION

If the connection between the CLIMATIC™ 60 and the 'DC60 is not correct (Offline) screen displays only the symbol **Off**.

In this case, check: :

- the connection between CLIMATIC™ 60 and DC60
- the setting of the DC60
- the power of CLIMATIC™ 60

If the connection between the CLIMATIC™ 60 and the 'DC60 is correct (Online) to power up the screen displays only the symbol **Init**. This phase allows the CLIMATIC™ 60 to set up the DC60 with options of rooftop.

After some seconds, DC60 is operational.

## PRESENTATION

### Showing

The diagram shows the DC60 control panel with several callout boxes explaining the display elements:

- Control operating mode:** | Heat. | Cool. | Auto |
- Value:** The large digital display showing temperature and other metrics.
- Label or clock:** The time and date display at the bottom of the screen.
- Fan operating mode:** The fan speed indicator at the top right of the display.
- Schedule mode:**
  - Day
  - Day I
  - Day II
  - Night
  - BMS
- Status indicators (left side):**
  - Staus
  - Alarm
  - Pump
  - Compressor(s)
  - Defrost
  - Condenser(s)
  - Heaters

Hidden : to stop  
Visible : running  
Blinking : in fault

## PRESENTATION

### Buttons



## USE

### □ On/Off unit

By supporting a few seconds the button □, you can activate or not (On/Off) the rooftop connected.  
 If the symbol □ F F completed by the time ● is displayed, the rooftop is stopped and the DC60 in sleep mode.  
 To restart the unit, press the button □ a few seconds.



### ⌚ Setting time

At initialization of the DC60, the CLIMATIC™ 60 are synchronized time and day of week with the clock DC60.

To view the time, briefly, press the button ⌚.  
 To set the time press the button ⌚ a few seconds.

The **hour** value flashes.  
 Turn the knob ⌚ to adjust the desired value.  
 Press the knob ⌚ to select your choice.



Then the **minute** value flashes.  
 Turn the knob ⌚ to adjust the desired value.  
 Press the knob ⌚ to select your choice.

| Mon Monday | Tue Tuesday | Wed Wednesday | THU Thursady | FRI Friday | SaT Saturday | SUN Sunday |

Then the **weekday** value flashes.  
 Turn the knob ⌚ to adjust the desired value.  
 Press the knob ⌚ to select your choice.

After a few seconds DC60 communicates the new time to the CLIMATIC™ 60.

## USE

### Information available

By rotating the knob , you can view or modify the following values:

#### DC60 set in light mode

**set** : Volatile temperature set point current mode (°C)

- : Indoor (Room) temperature (°C)

#### Set Volatile Temperature set point

This item allows you to view and/or modify the control temperature required for the Roof-Top selected.

If this point is changed, this value is used until the scheduling changes mode (A, B, C, D, BMS).

At each change of the mode, the CLIMATIC™ 60 sets the value of this set point on the preset value in the mode concerned.

#### Indoor (room) temperature

This item indicates the measured air temperature in the room conditioning.

The room temperature isn't available if the CLIMATIC™ 60 is configured to supply control.

#### DC60 set in full mode

- **Unit** : Number of rooftop connected to the DC60
- **SP t set**  : Predetermined temperature set point current mode (°C)
- **SEt set** : Volatile temperature set point current mode (°C)
- **AL set** : Alarms code
- **t Ou** : Outdoor temperature (°C)
- **t Su** : Supply temperature (°C)
- **t In\*** : Indoor (Room) temperature (°C)
- **h In\*** : Indoor (Room) humidity (%hr)
- **Co2\*** : Indoor (Room) Air quality (ppm)
- **Eco\*** : Opening of fresh air damper (%)

\*: Available if the option is enabled.

: Available if the level 2 is activated.

**set** : Adjustable with 'DC60.

#### Unit Unit connected

This item can know the number of rooftop connected to the DC60.

## USE

### Set Volatile temperature set point

This item allows you to view and/or modify the control temperature required for the rooftop selected.

If this point is changed, this value is used until the scheduling changes mode (A, B, C, D, BMS).

At each change of the mode, the CLIMATIC™ 60 sets the value of this set point on the preset value in the mode concerned.

### SP - t Predetermined temperature set point

If level 2 is active, this item allows you to view and/or change the preset temperature control for the active mode.

### AL - Alarms code

This item can see the code of different active alarms on the rooftop.

If the rooftop isn't in alarm, this item is to 0.

By this item it's possible to reset the alarm activated. To do this set the value of the item to the value 0.

### t - O u Outdoor temperature

This item indicates the measure temperature of the air outside.

### t - S u Supply temperature

This item indicates the measure of outlet air temperature of the rooftop.

### t - I n Indoor (Room) temperature

This item indicates the measured air temperature in the room conditioning.

The room temperature isn't available if the CLIMATIC™ 60 is configured to supply control.

### h - I n Indoor (Room) relative humidity

This item shows the measured relative humidity of the air in the room conditioning.

The room humidity isn't available if the option of humidity management isn't set.

### CO<sub>2</sub> CO<sub>2</sub> measurement

This item indicates the measured rate of CO<sub>2</sub> in conditioning room, in ppm.

The measurement of CO<sub>2</sub> isn't available if the option isn't set.





### E c o Opening of fresh air damper

This item indicates the measured value of the opening rate of the fresh air damper, in%, (mixture of outside air and return air)

This value is only available if the rooftop is equipped with this option.

## Setting value



If the value of the selected item is modified :





- To activate the modified value, press the knob .
- The **SET** symbol appears on the right side of the value.
- Turn the knob  to adjust the desired value.
- Press again on the knob  to confirm your choice.
- The **SET** symbol is no longer displayed on the right side of the value.
- The rotation of the knob  allows to select a new item.

## LEVEL 2 ACTIVATION



(2 buttons on the right simultaneously)

Simultaneously press the keys  and .

After some seconds the text     appears and the value '000' flashes.

Turn the knob  to change the value to select the number 066. Then validate the code by pressing the knob.

If the code is wrong access the setup menu is not possible and the DC60 returns to the previous display.

If the code is correct the level 2 is actif, and symbol  is displayed to the right of the value.

The level 2 is turned off automatically every hour.

The 'DM60' display is personalized for the user. It allows an overview of unit operation and allows access to certain parameters.

The 'DM60' is designed for connection of remote roof-top.

## INSTALLATION

**WARNING : An error connecting to the display immediately causes the deterioration of this one or BM60.**

The optional delivered DM60 is designed to be wall mounted:

- position the cable through the rear
- fasten the rear wall using button head screws provided in the package
- connect the cable from the main board on the jack on the back of the DM60 screen
- attach the front panel on the back using provided countersunk screws
- snap frame.

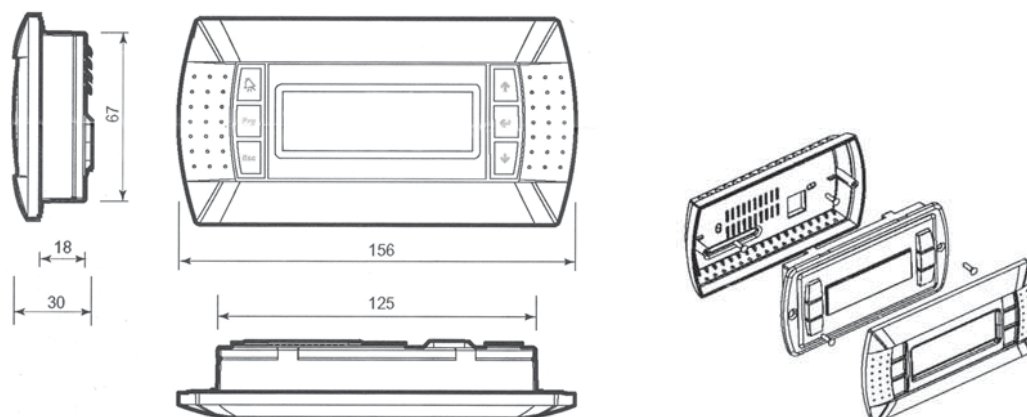

The display is connected to CLIMATIC™ DM60 on the screw terminals of the card DT50.

The connection must be wired as follows:

- for a length of 0 to 300 m: AWG22 (0.34 mm<sup>2</sup>), two crossed pairs with screen.
- for a length of 0 to 500 m: LiYCY-P (0.34 mm<sup>2</sup>), two pairs shielded general.

The cable length should not exceed 500 m.

For a better protection of electromagnetic disturbances LENNOX recommends the icable LiYCY-P installation.

## CONNECTION ON THE DT50 SPLITTER

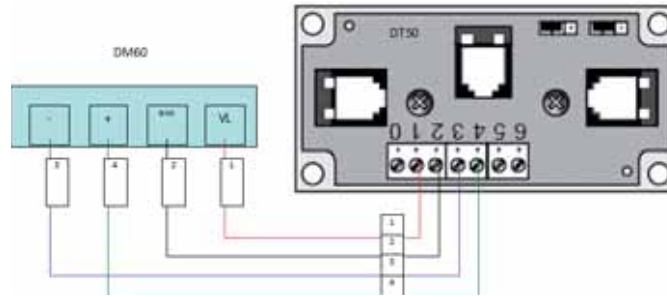

### DT50 dispatcher installation guide

The board is equipped with three RJ12 phone jacks and a screw connector (SC).

Terminal	Wire function	Connections
0	Earth	Shield
1	+VRL ( $\approx 30$ Vdc)	1st pair A
2	GND	2nd pair A
3	Rx/Tx-	3rd pair A
4	RX/Tx+	3rd pair B
5	GND	2nd pair B
6	+VRL ( $\approx 30$ Vdc)	1st pair B

### Jumpers:

The "displays" are directly supplied by the Climatic™ board with a 30 VDC power supply. Pay attention to the value of this voltage when multiple cards are used.

J14 and J15 closed or cut the power supply:

- J14 and J15 set between 1-2: connectors A, B, C and SC are in parallel. Power is available on all connectors.
- J14 and J15 set between 2-3: B and C connectors are supplied in parallel but the connectors A and SC are not. Displays connected to these ports are not powered.

If J14 and J15 are set differently, the DT50 dispatcher DOESN'T WORK and therefore connected displays don't work.

### Display's ferrites protection

To avoid appearance of RF interference that may cause destruction of components in the displays, you need to equip the cable of a ferrite, during its installation (provided by LENNOX).

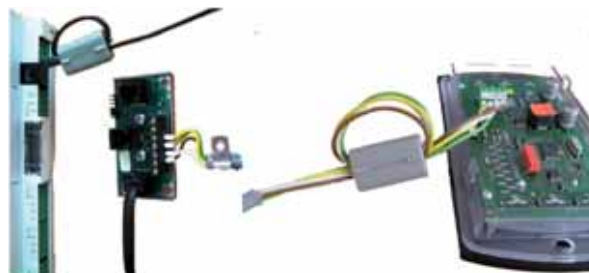



## DM60 AND COMMUNICATION MASTER/SLAVES

If the master/slaves communication bus is connected between several rooftop (maximum 8).  
The 'DM60', connected on this bus, allows viewing, alternatively, information of all connected units.

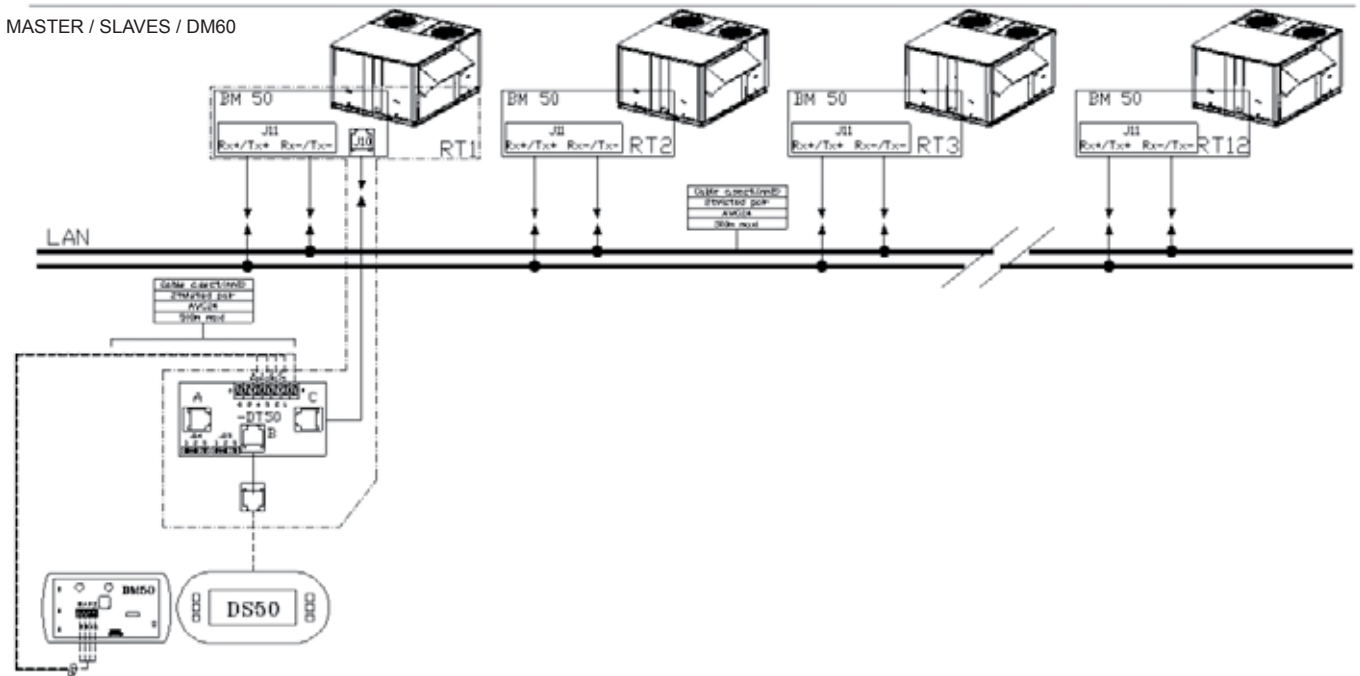

The inter-bus boards (pLan) CLIMATIC™ connects to connector J8 on the BM60 cards.  
Connection with 'star' is not recommended for optimum performance it is advisable to connect a maximum of two cables per unit.  
The connection must be wired as follows:

- For a length of 0 to 300 m: AWG22 (0.34 mm<sup>2</sup>), a twisted pair shielded.
- For a length of 0 to 500 m: LiYCY-P (0.34 mm<sup>2</sup>), a pair overall shield.

cable length should not exceed 500 m.  
For better protection of electromagnetic disturbances Lennox recommends the installation of cable LiYCY-P.

**WARNING : The BM60 24Vac cards should not be connected to the 'earth'.**

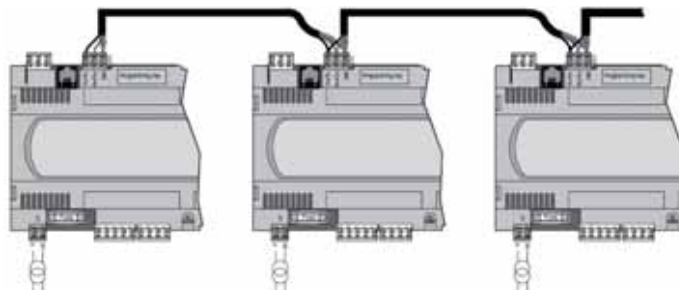

## CONFIGURATION

### Brightness / Contrast

The display is equipped with a contrast, but it can be adjusted manually. For manual adjustment of contrast, simultaneously press the 'alarm' and 'prg' keys and press 'arrow' or 'down arrow' buttons to increase or decrease the contrast.

### Configuring the terminal's address

The terminal's address (DC60 or DM60) must be checked after putting the card to 'On':

- access the setup mode by pressing the 'arrow', 'enter' and 'down arrow' keys for at least 5 seconds.
- press 'enter' to place the cursor on 'setting'
- with 'arrow' or 'down arrow' set the address of the display 31 of DM60, then confirm by pressing 'enter'

The screen 'display address changed' is displayed.

If after 5 seconds the display is not correct:

- access, a second time, the setup mode by pressing the 'arrow', 'enter' and 'down arrow' keys for at least 5 seconds, up to the next screen.
- press 'enter' to place the cursor on 'setting'
- press 'enter' a second time to place the cursor on the I / O board address line
- with 'arrow' or 'down arrow' replace '-' by the address of the BM60 connected and confirm by pressing 'enter'

## FUNCTIONALITY OF THE DM60

### Rooftop selection

A DM60 can be connected to 8 units per the pLan bus. DM60 screens connected, alternatively, to one of BM60.

The next screen allows selection of the unit to display:



Each of the 8 rooftops is represented by a number. The selected rooftop is indicated by its number which is framed. Each time you press the 'down arrow' button, it connects the display to the next rooftop. Pressing 'enter' key returns to the main screen.

Main



Top left :

Control in heating mode or control in cooling mode

- Small, numerical value: volatile set point temperature: View and/or modify the offset, or set point, of the desired temperature control for the selected rooftop. Pressing the 'arrow' button increases the set point value. Pressing the 'down arrow' button decreases the set point value.  
If the setpoint is changed, this value is maintained as long as the rooftop scheduling doesn't change modes (night, day, day I, day II, BMS).  
At each change of the mode the CLIMATIC™ 60 sets the value of this setpoint on the preset value in the mode concerned.
- Big, numerical value: measured air temperature value in the conditioned space.

Top right:

Ventilation state

Bottom right:

State mode based on the schedule, hour, minute, of CLIMATIC™ :

- Night mode
- Day mode
- Day I mode
- Day II mode

Bottom left:

If the unit is in alarm, this symbol is displayed

- Pressing the 'alarm' button directs you to the alarm list display.
- Pressing the 'prg' button directs you to rooftop setup menus display.
- Pressing the 'esc' button takes you to the selected rooftop choice display.
- Pressing the 'arrow' button increases the set point value.
- Pressing the 'enter' button takes you to the rooftop operation display.
- Pressing the 'down arrow' button decreases the set point value.

## Rooftop off



If the rooftop is Off, this screen is activated.

- pressing the 'alarm' button directs you to the alarm list display.
- pressing the 'prg' button directs you to the rooftop setup menus display.
- pressing the 'esc' button takes you to the selected rooftop choice display.

## Rooftop operation

- pressing the 'alarm' button directs you to the alarm list display.
- pressing the 'esc' button takes you to the main display.
- pressing the 'arrow' button directs you to the previous screen.
- pressing the 'down arrow' button directs you to the next screen.



View/edit, status of the unit (On/Off).

Pressing the 'prg' button reverses the On/Off state of the unit.





On the left of the house:

- outdoor humidity value visualization (if enabled).
- outdoor temperature value visualization.



In the house:

- indoor humidity value visualization(if enabled).
- indoor temperature value visualization.
- indoor air quality rate visualization(if enabled).

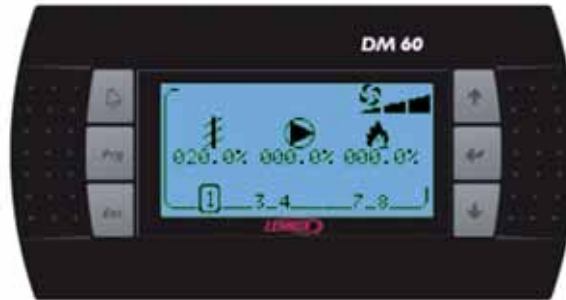

-  Heating mode set point visualization
-  Cooling mode set point visualization



-  Fresh air damper opening percentage visualization
-  Engaged compressor percentage visualization
-  Engaged heaters percentage visualization

- pressing the 'alarm' button directs you to the alarm list display.
- pressing the 'esc' button takes you to the main display.
- pressing the 'arrow' button directs you to the previous screen.
- pressing the 'down arrow' button directs you to the next screen.

**Alarm list**



- History used to store the last 99 alarms occurred on the unit.
- each alarm is stored on the date and time the fault occurred.
  - an active alarm is signified by the 'bell' symbol.
  - an reseted alarm is signified by the '.' symbol.
  - each alarm is signified by a 3 digit code

To have the text of fault code, position the cursor on the desired line, by using the 'up arrow' or 'down arrow' and then confirm by pressing 'enter'

- pressing the 'esc' button takes you to the main display.
- pressing the 'arrow' button positions you in the list.
- pressing the 'enter' button takes you to the clear display of failure code.
- pressing the 'down arrow' button positions you in the list.

Setup menus



Access to the setup menus is protected by a password. The password must be entered digit by digit. If the password is correct, the lock opens, and the selection of the function choice is active.

- Pressing the 'alarm' button directs you to alarm list display.
- Pressing the 'esc' button takes you to the main display.
- Pressing the 'arrow' button increases the password digit value or selects the previous function.
- Pressing the 'enter' button it puts you on the next digit password, or directs you to the selected function screen.
- Pressing the 'down arrow' button decreases the password digit value or selects the next function.

Setting; Temperature



View/edit, the current schedule mode of the heating mode setpoint

View/edit, the current schedule mode of the cooling mode setpoint

- Pressing the 'alarm' button directs you to alarm list display.
- Pressing the 'esc' button directs you to rooftop menu setup display.
- Pressing the 'up arrow' button increases the set point value.
- Pressing the 'enter' button commits the changes then it puts you on the next or previous setpoint.
- Pressing the 'down arrow' button decreases the set point value.

## Setting; Reset Alarms



View/edit, alarm and safety reset

- Pressing the 'alarm' button directs you to alarm list display.
- Pressing the 'esc' button directs you to the rooftop menu setup display.
- Pressing the 'up arrow' button reverses the state.
- Pressing the 'enter' button resets alarm: if the 'reset' word is selected, then it directs you to the rooftop setup menus display.
- Pressing the 'down arrow' button reverses the state.

## Setting; rooftop On/Off



View/edit, On/Off status of the unit.

- Pressing the 'alarm' button directs you to the alarm list display.
- Pressing the 'esc' button 'Esc' directs you to the rooftop setup menu display.
- Pressing the 'up arrow' button 'Up Arrow' reverses the state.
- Pressing the 'enter' button validates the selection, then directs you to the rooftop setup menu display.
- Pressing the 'down arrow' button reverses the state.

## Setting; Clock of CLIMATIC™



View/edit, hour, minute, day of month, month and year of the CLIMATIC™ clock.

- Pressing the 'alarm' button directs you to the alarm list display.
- Pressing the 'esc' button directs you to the rooftop setup menus display.
- Pressing the 'up arrow' button increases the selected value.
- Pressing the 'enter' button commits the change and it puts you to the next value.
- Pressing the 'down arrow' button decreases the selected value.

## Setting; CLIMATIC™ schedule



View/edit, hour and minutes of each zone beginning.  
View/edit, the zone operating mode.

The schedule is different each weekday. You must set a schedule for monday, tuesday, ..., and sunday.  
The visualization of another weekday is done by pressing the 'prg' button.

- Pressing the 'alarm' button directs you to the alarm list display.
- Pressing the 'prg' button displays the next weekday.
- Pressing the 'esc' button directs you to rooftop setup menus display.
- Pressing the 'up arrow' button increases and validates the selected value.
- Pressing the 'enter' button commits the change and it puts you to the next value.
- Pressing the 'down arrow' button decreases and validates the selected value.



# BALTIC™

# CERTIFICATES

---

**Ref :** BALTIC\_Certificates-IOM-0412-E

<b>CE CONFORMITY DECLARATION</b>	<b>94</b>
<b>EUROVENT</b>	<b>96</b>
<b>CERTIGAZ</b>	<b>97</b>

Certificates are given for information only.  
To get the uptodate certificates, please contact your local LENNOX representative.

Bureau Veritas S.A. is a Notified



body under the number 0062



**ATTESTATION D'APPROBATION DE SYSTEME DE QUALITE  
CERTIFICATE OF QUALITY SYSTEM APPROVAL  
N° CE-PED-H-LGL 001-11-FRA**

BUREAU VERITAS S.A., agissant dans le cadre de sa notification (numéro d'organisme notifié 0062), atteste que le système de qualité appliqué par le fabricant pour la conception, la fabrication, l'inspection finale et les essais des équipements sous pression identifiés ci-après, a été examiné selon les prescriptions du module H de l'annexe III de la directive "Equipements sous pression" N° 97/23/CE et est conforme aux dispositions correspondantes de la directive. BUREAU VERITAS S.A., acting within the scope of its notification (notified body number 0062), attests that the quality system operated by the manufacturer for design, manufacture, final inspection and testing of the pressure equipment identified hereunder has been examined against the provisions of annex III, module H, of the Pressure Equipment directive n° 97/23/EC, and found to satisfy the provisions of the directive which apply to it.

Fabricant (Nom) / Manufacturer (Name): **LENNOX LGL FRANCE**

Adresse / Address: **ZI "Les meunières" - BP.69780 MIONS, FRANCE**

Marque commerciale / Branding name:

Description des équipements / Equipment description: **Climatiseur autonome de toiture de type ROOFTOP et refroidisseur de liquide à condensation d'air de type CHILLER**

Identification des équipements concernés (liste en annexe le cas échéant) / Identification of equipment concerned (list attached where necessary):

**Liste des équipements en annexe I**

Cette attestation est valable jusqu'au (MM/JJ/AAAA) / This certificate is valid until (MM/DD/YYYY): **02/23/2014**

Le maintien de l'approbation est soumis à la réalisation par le Bureau Veritas des audits, essais et vérifications selon le contrat signé par le fabricant et le Bureau Veritas. The approval is conditional upon the surveillance audits, tests and verifications to be carried out by Bureau Veritas, as per the provisions stated in the agreement signed by both the manufacturer and Bureau Veritas.

Cette attestation est présumée nulle et le fabricant supportera seul les conséquences de son utilisation, si les assurances - données par le fabricant lors de la demande d'intervention - en matière (a) d'application de son système qualité approuvé, (b) de conformité de son équipement au type et (c) d'inspection et d'essais des produits finis se révèlent inexactes et, de manière générale, si le fabricant ne respecte pas l'une ou l'autre des obligations mises à sa charge par la directive n° 97/23/CE du 29 mai 1997 telle que transposée dans le(s) droit(s) national(aux) applicable(s). This certificate shall be deemed to be void and the manufacturer shall alone bear any consequences pursuant to its use, where the manufacturer fails to comply with his undertakings as per the agreement in respect of (a) implementation of the approved quality system, (b) conformity of the equipment with the type and (c) inspection and tests on the final product, and generally where the manufacturer fails in particular to comply with any of his obligations under directive nr 97/23/EC of 29 may 1997 as transposed in the applicable law(s).

Etabli à / Made at	Le (MM/JJ/AAAA) / On (MM/DD/YYYY)	Approuvé et Enregistré en / Approved and Recorded in	Signé par / Signed by	Signature autorisée par Organisme Notifié / Signature authorised by Notified Body No 0062
<b>DIJON</b>	<b>02/24/2011</b>	<b>France</b>	<b>Alain Religieux</b>	

Code d'enregistrement / Registration code: **2011/181.17,2087/P**  
La présente attestation est soumise aux Conditions Générales de Service de Bureau Veritas jointes à la demande d'intervention signée par le demandeur. This certificate is subject to the terms of Bureau Veritas General Conditions of Service attached to the agreement signed by the applicant.



**BUREAU  
VERITAS**

Bureau Veritas S.S is a Notified Body under the number 0062

### Annexe I

**Certificat N°CE-PED-H-LGL-001-11-FRA**

**Affaire : LGL LENNOX France**

Gamme	Modèle	PS LP		PS HP		TS LP		TS HP		Fluide	Groupe
		Mini	Maxi	Mini	Maxi	Mini	Maxi	Mini	Maxi		
ROOFTOP du type BALTIC de 22 à 85 kW	BAC, BAH, BAM, BAG, BWH, BWM Taille 24-30-38-42-45-52-57-65-75-85	-1	28	-1	42	-20	50	-20	110	R410A	2
ROOFTOP du type BALTIC de 20 à 75 kW	BCK, BHK, BGK, BOK Taille 20-25-30-35-40-45-50-60-70	-1	20	-1	29	-20	50	-20	110	R407C	2
ROOFTOP du type FLEXY de 80 à 200 kW	FCM, FHM, FGM, FDM, FWH, FWM, FGM, FDM Taille 085-100-120-150-170-200-230	-1	29,5	-1	42	-20	50	-20	110	R410A	2
ROOFTOP du type FXK	Taille 025-030-035-040-055-070-085-100-110-140-170-200	-1	20	-1	29	-20	50	-20	110	R407C	2
CHILLER du type NEOSYS de 200 kW à 1080 kW	NAC : 200-230-270-300-340-380-420-480-540-600-640-680-760-840-960-1080 NAH : 200-230-270-300-340-380-420-480	-1	29,5	-1	42	-20	50	-20	110	R410A	2
CHILLER du type MWC de 200 kW à 700 kW	MWC & MRC : 180-230-280-330-380-450-510-570-650-720	-1	29,5	-1	42	-20	50	-20	110	R410A	2
CHILLER du type HYDROLEAN de 20 kW à 165 kW	SWC, SWH, SWR : 020-025-035-040-050-065-080-090-100-120-135-165	-1	20	-1	29	-20	50	-20	110	R407C	2



EUROVENT CERTIFICATION COMPANY SCRL  
53 rue Turbigo 75003 Paris FRANCE - RCS Paris B 393 363 460 - Code APE : 748K

Certification Diploma N° :  
09.04.422

EUROVENT Certification Company certifies that

**Rooftops**

from

**LGL France S.A.**

Located at

Z.I. Les Meurieres - BP 71, 69780 Mions Cedex, France

**EUROVENT**  
CERTIFIED PERFORMANCE  
Trade name  
LENNOX EUROPE  
LENNOX

have been assessed according the requirements of following standard

**OM-13-2011**

The list of certified products is displayed at :

<http://www.eurovent-certification.com>

LGL France S.A.

is authorised to use the EUROVENT Certification mark in accordance with the rules  
specified in the Operational Manual

**OM-13-2011**

Erick MELQUIOND  
Managing Director

Approval date : 2009/04/03

Re-checked on : 2012/03/15

Valid until : 2012/06/15

(« Gas appliances » 90/396 EEC Directive)  
(Directive 90/396/CEE « Appareils à gaz »)

Numéro : **1312BO3925** (rév. 4)

**CERTIGAZ**, after examination and verifications, certifies that the appliance :  
**CERTIGAZ**, après examen et vérifications, certifie que l'appareil :

- **Manufactured by :** **LENNOX FRANCE**  
*Fabriqué par :* **Z.I. LONGVIC - BP 60**  
**F-21602 LONGVIC CEDEX**
- **Trade mark and model(s) :**

<b>LENNOX</b>
---------------

  
*Marque commerciale et modèle(s)*
  - > BG-B20 – BG-B33 – BG-C20
  - > BG-C46 – BG-D33 – BG-D60
  - > BG-E60 – BG-E120
  - > BG-BM20 – BG-BM33 – BG-CM20 – BG-CM46
  - > BG-DM33 – BG-DM60 – BG-EM60 – BG-EM120
- **Kind of the appliance :** **GAS AIR HEATER UNIT FOR ROOF TOP (B22)**  
*Genre de l'appareil :* **MODULE DE CHAUFFAGE POUR CLIMATISEURS DE TOITURE (B22)**
- **Type designation :** **BG-B20**  
*Désignation du type :*

Destination countries <i>Pays de destination</i>	Pressures (mbar) <i>Pressions (mbar)</i>	Categories <i>Catégories</i>
FR	20/25 ; 37	I12Er3P
BE	20/25 ; 37	I2EB ; I3P
PT-CH-ES-GB-CZ-GR-IE	20 ; 37	I12H3P
DE	20 ; 50	I2E ; I3P
DK-SE-IT-CZ-EE-LT-LV	20	I2H
NL	25 ; 37-50	I12L3P
HU	30 ; 50	I3P
CY-MT	50	I3P
SI-SK	20 ; 37 ou 50	I12H3P
PL	20	I2E
PL	36	I3P
SE	37	I3P
CZ	20 ; 37	I12H3P

is in conformity with essential requirements of « Gas appliances » directive 90/396/EEC .  
est conforme aux exigences essentielles de la directive "Appareils à gaz" 90/396/CEE.

[www.lennox europe.com](http://www.lennox europe.com)

**SALES OFFICES :**

**BELGIUM AND LUXEMBOURG**

+ 32 3 633 3045

**RUSSIA**

+7 495 626 56 53

**FRANCE**

+33 1 64 76 23 23

**SPAIN**

+34 902 533 920

**GERMANY**

+49 (0) 6071 3915919

**UKRAINE**

+380 44 461 87 79

**ITALY**

+ 39 02 495 26 200

**UNITED KINGDOM AND IRELAND**

+44 1604 669 100

**NETHERLANDS**

+ 31 332 471 800

**POLAND**

+48 22 58 48 610

**OTHER COUNTRIES :**

**PORTUGAL**

+351 229 066 050

**LENNOX DISTRIBUTION**

+33 4 72 23 20 00



**BALTIC-IOM-0412-E**

Due to Lennox's ongoing commitment to quality, the specifications, ratings and dimensions are subject to change without notice and without incurring liability.

Improper installation, adjustment, alteration, service or maintenance can cause property damage or personal injury.

Installation and service must be performed by a qualified installer and servicing agency