



INSTALLATION MANUAL

This manual provides the procedures of installation to ensure a safe and good standard of operation for the air conditioner unit.
Special adjustment may be necessary to suit local requirements.

Before using your air conditioner, please read this instruction manual carefully and keep it for future reference.

CEILING CONCEALED SPLIT TYPE AIR CONDITIONER

MODEL

COOLING UNIT

CC10C / ACC10C / MCC010C
SL10B / ALC10B / MLC010B

CC15C / ACC15C / MCC015C
SL15B / ALC15B / MLC015B

CC20C / ACC20C / MCC020C
SL20B / ALC20B / MLC020B

CC25C / ACC25C / MCC025C
SL25B / ALC25B / MLC025B

CC30C / ACC30C / MCC030C
SL30C / ALC30C / MLC030C

CC40C / ACC40C / MCC040C
SL40C / ALC40C / MLC040C

CC50C / ACC50C / MCC050C
SL50C / ALC50C / MLC050C

CC60C / ACC60C / MCC060C
SL60C / ALC60C / MLC060C

HEAT PUMP

CC10CR / ACC10CR / MCC010CR
SL10BR / ALC10BR / MLC010BR

CC15CR / ACC15CR / MCC015CR
SL15BR / ALC15BR / MLC015BR

CC20CR / ACC20CR / MCC020CR
SL20BR / ALC20BR / MLC020BR

CC25CR / ACC25CR / MCC025CR
SL25BR / ALC25BR / MLC025BR

CC30CR / ACC30CR / MCC030CR
SL30CR / ALC30CR / MLC030CR

CC40CR / ACC40CR / MCC040CR
SL40CR / ALC40CR / MLC040CR

CC50CR / ACC50CR / MCC050CR
SL50CR / ALC50CR / MLC050CR

CC60CR / ACC60CR / MCC060CR
SL60CR / ALC60CR / MLC060CR



CONTENTS

- Safety Precautions	page 2
- Installation Diagram	page 3
- Outline and Dimensions	page 3
- Installation Of The Indoor Unit	page 5
- Installation Of The Outdoor Unit	page 6
- Refrigerant Piping	page 7
- Electrical Connection	page 8
- Purging The Refrigerant Piping	page 12
- Additional Charge	page 13
- Overall Checking	page 14
- Standard Operating Condition	page 14
- Auto Random Re-Start Function	page 15
- Service And Maintenance	page 15
- Trouble Shooting	page 16

SAFETY PRECAUTIONS

Before installing the air conditioner unit, please read the following safety precautions carefully.

Warning





- Installation and maintenance should be performed by qualified persons who are familiar with local code and regulation, and experienced with this type of appliance.
- All field wiring must be installed in accordance with the national wiring regulation.
- Ensure that the rated voltage of the unit corresponds to that of the name plate before commencing wiring work according to the wiring diagram.
- The unit must be GROUNDED to prevent possible hazard due to insulation failure.
- All electrical wiring must not touch the refrigerant piping, compressor and any moving parts of the fan motors.
- Confirm that the unit has been switched OFF before installing or servicing the unit.

IMPORTANT

DO NOT INSTALL OR USE THE AIR CONDITIONER UNIT IN A LAUNDRY ROOM.

Caution

Please take note on the following important points when installing.

- **Do not install the unit where leakage of flammable gas may occur.**
 If gas leaks and accumulates at the surrounding of the unit, it may cause fire ignition.
- **Ensure that the drainage piping is connected properly.**
 If the drainage piping is not connected properly, it may cause water leakage which will dampen the furniture.
- **Do not overcharge the unit.**
 This unit is factory pre-charged. Overcharge will cause over-current or damage to the compressor.
- **Ensure that the unit panel is covered back after service or installation.**
 Unsecured panel will cause unit to operate noisily.



INSTALLATION DIAGRAM

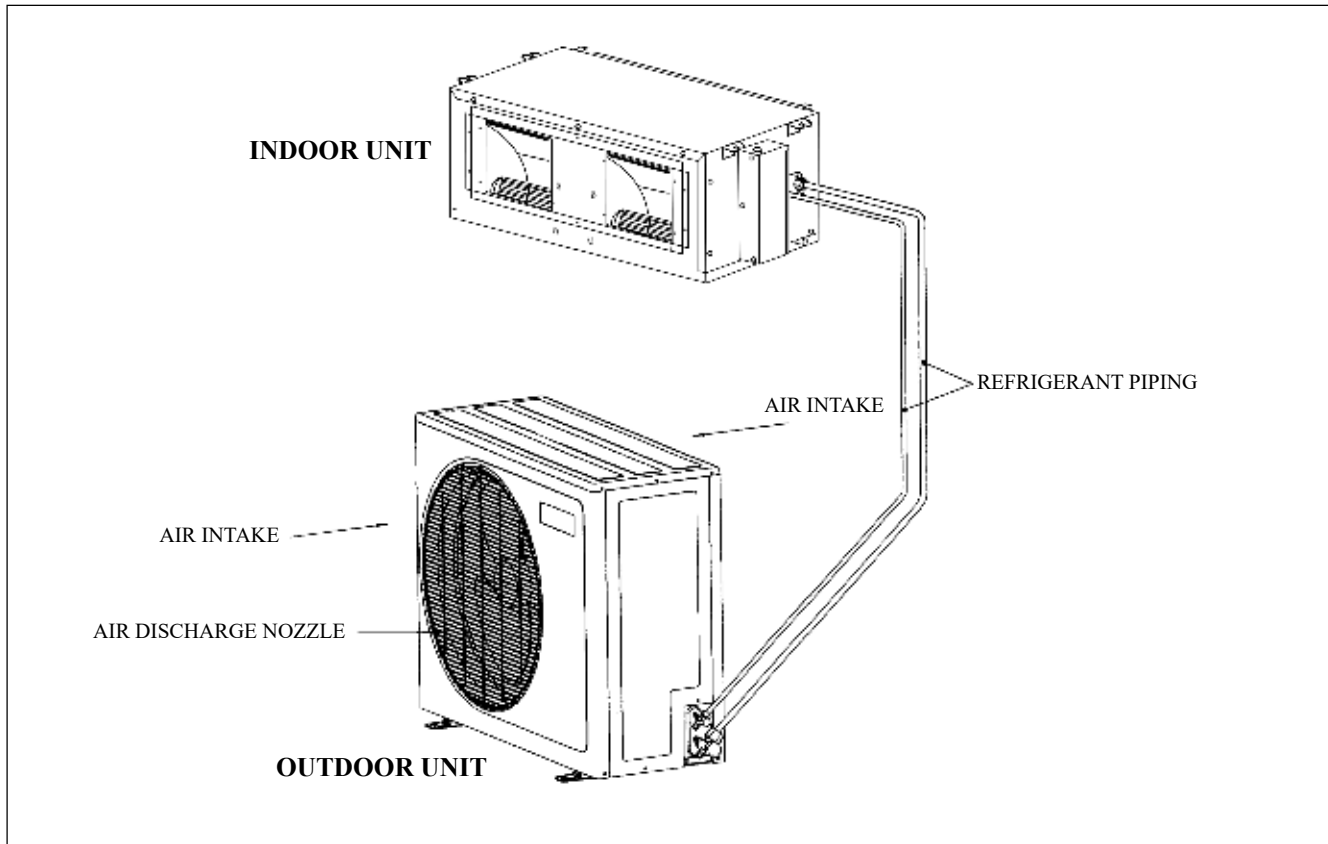

English

OUTLINE AND DIMENSIONS

Indoor Unit

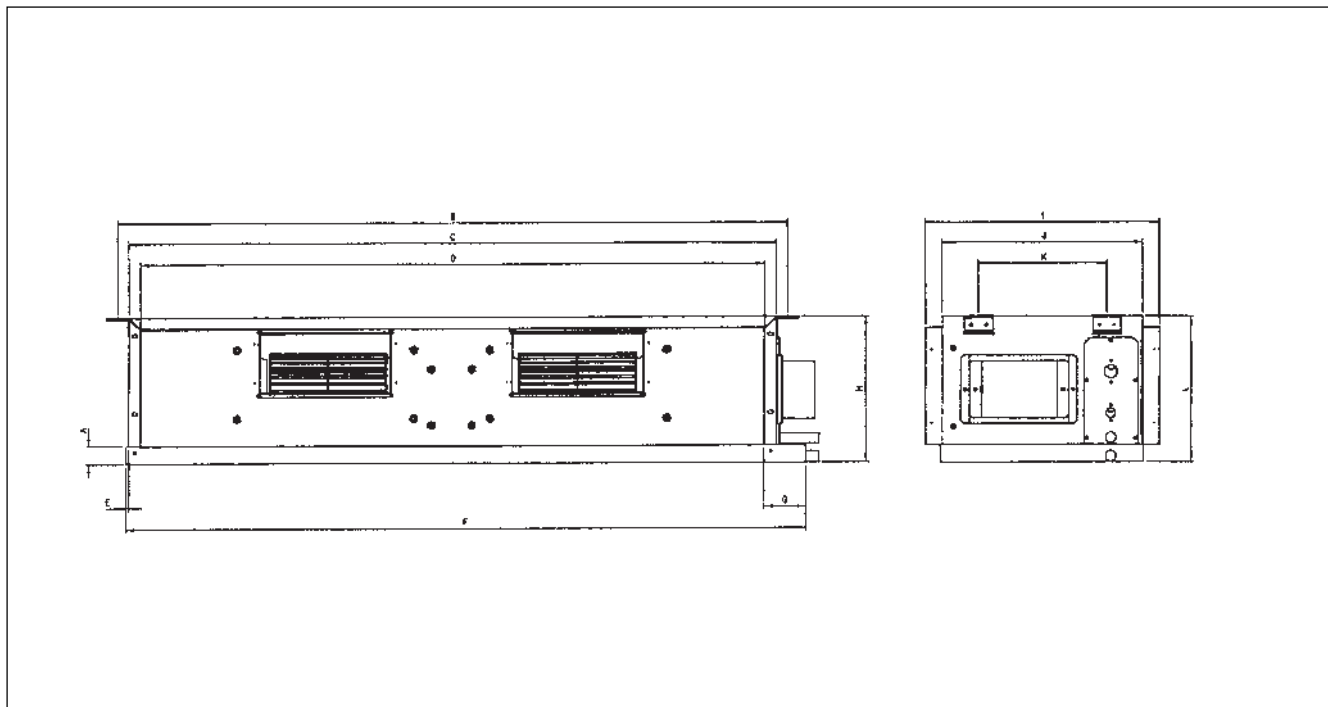

All dimensions are in mm

CC	A	B	C	D	E	F	G	H	I	J	K	L
10 C/CR	31	741	702	662	10	765	72	261	411	349	225	261
15 C/CR	31	881	842	802	10	905	72	261	411	349	225	261
20 C/CR	31	1041	1002	962	10	1065	72	261	411	349	225	261
25 C/CR	31	1176	1137	1097	10	1200	72	261	411	349	225	261



Indoor Unit (CC series)

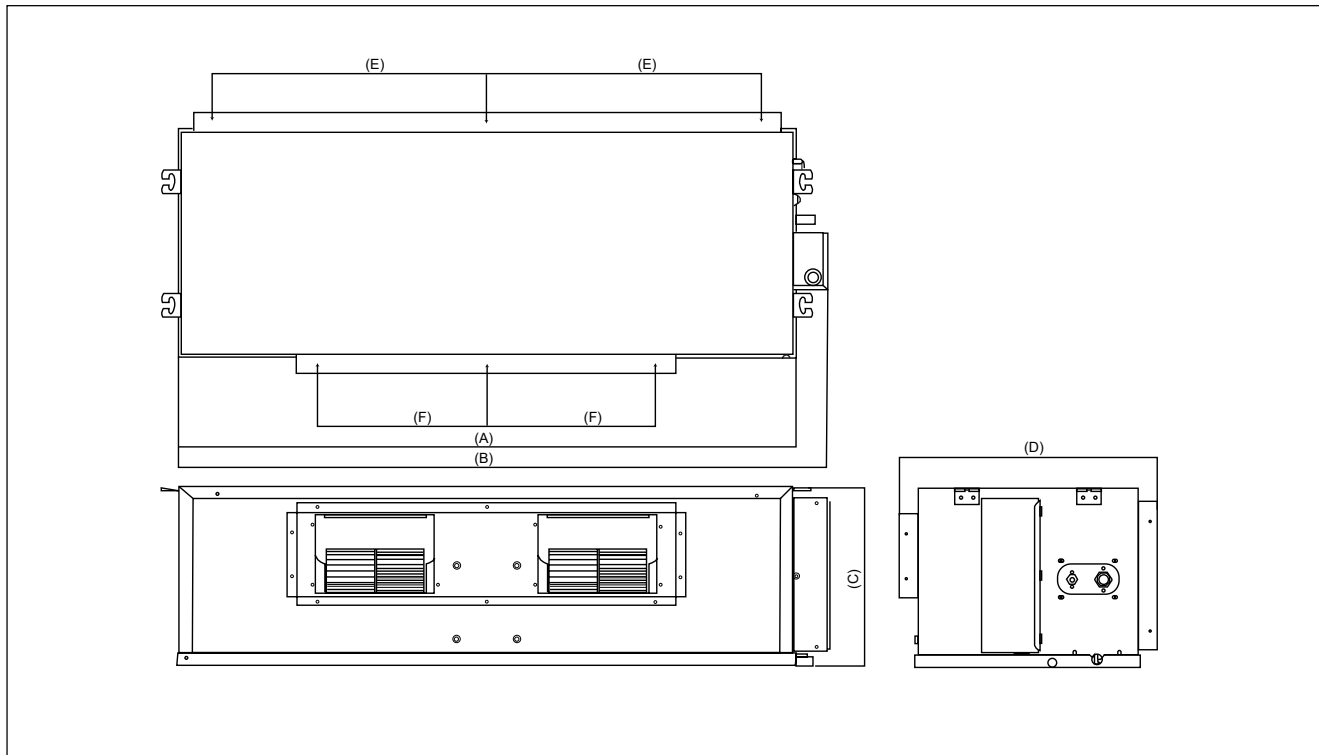

CC	A	B	C	D	E	F
30C/30CR	939.0	999.0	378.0	541.0	408.5	359.0
40C/40CR	1055.0	1115.0	378.0	541.0	466.5	359.0
50C/50CR	1309.0	1369.0	378.0	541.0	593.5	359.0
60C/60CR	1509.0	1569.0	378.0	541.0	693.5	359.0

Outdoor Unit (SL series)

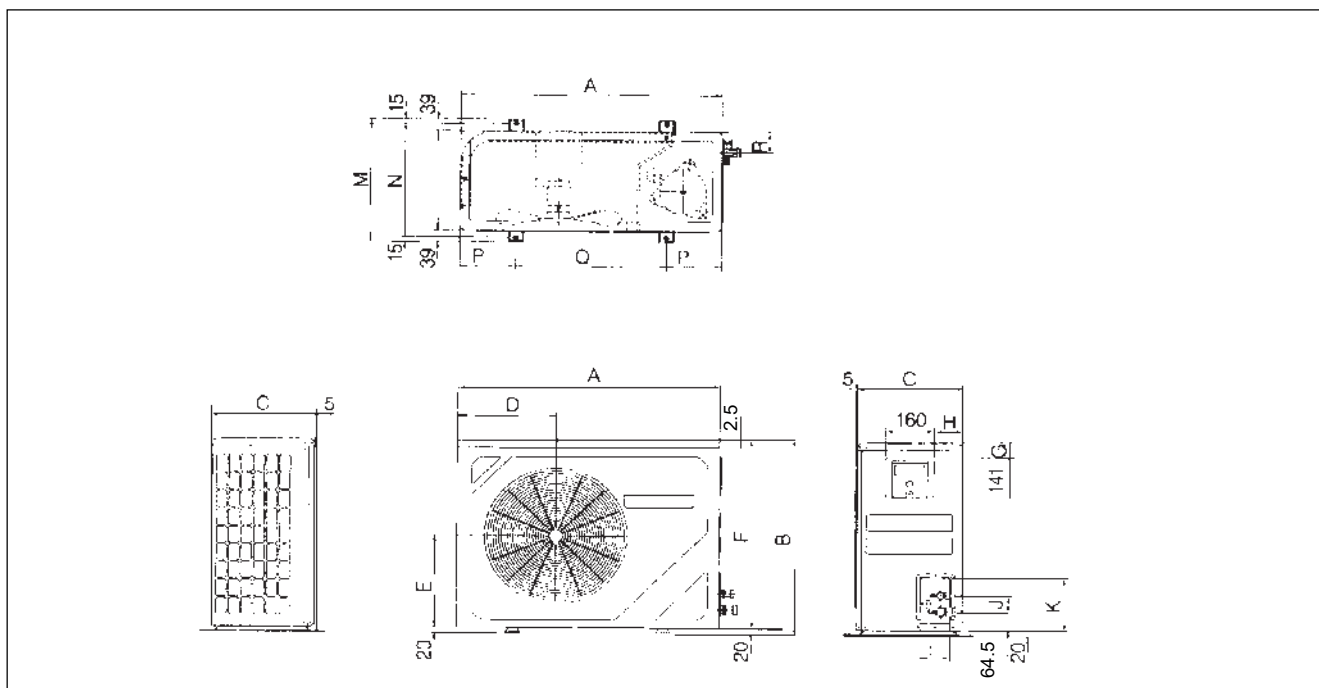

MODEL	A	B	C	D	E	F	G	H	J	K	L	M	N	P	Q	R
10B/10BR	740	494	270	266	233	474	52	60	54	166	92	348	318	129	482	68.5
15B/15BR	740	494	270	266	233	474	52	60	54	166	92	348	318	129	482	68.5
20B/20BR	840	646	330	297	309	626	46	90	64	177	106	408	378	124	492	78.5
25B/25BR	840	646	330	297	309	626	46	90	64	177	106	408	378	124	492	78.5



Outdoor Unit (SLC series)

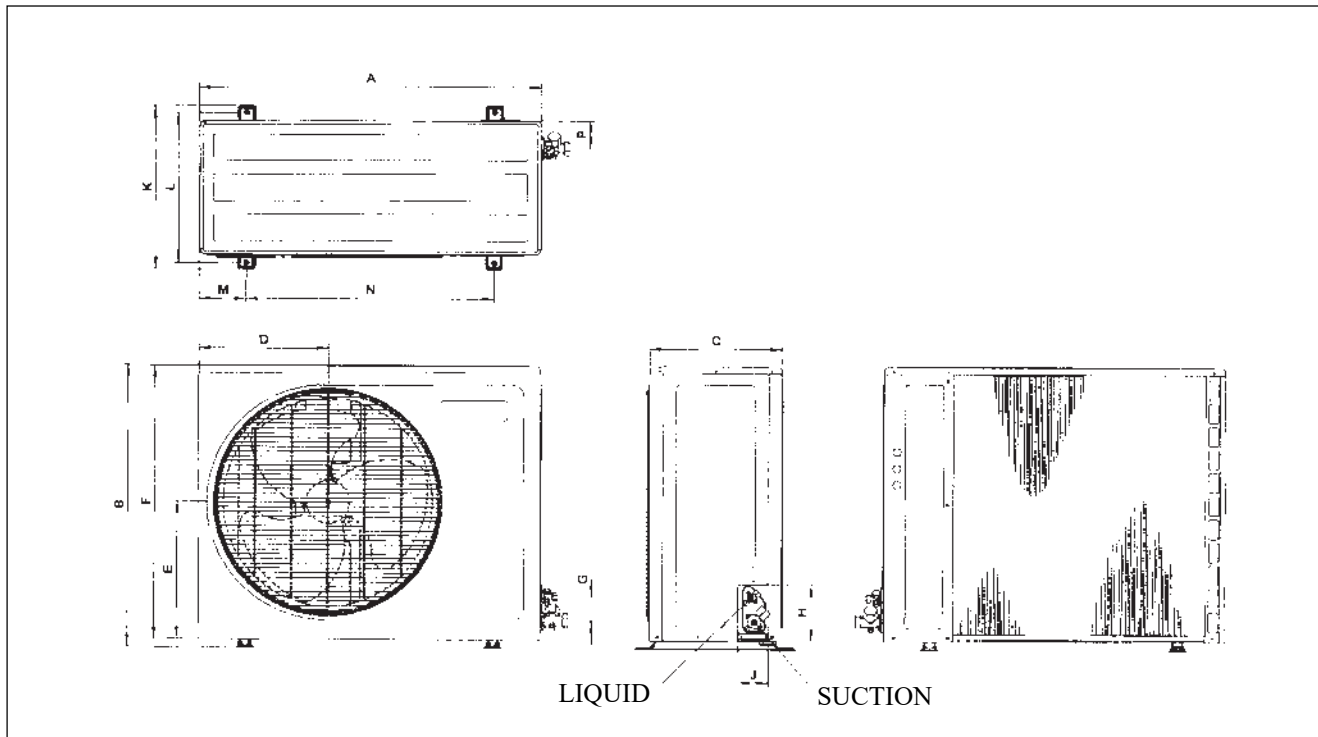

English

SL	A	B	C	D	E	F	G	H	J	K	L	M	N	P
30C/40C/50C/60C	1030	850	400	390	414	827	72	196	91	488	448	141.5	746.5	82

Caution Sharp edges and coil surfaces are potential locations which may cause injury hazards. Avoid from being in contact with these places.

INSTALLATION OF THE INDOOR UNIT

The indoor unit must be installed such that there is no short circuit of the cool discharge. Respect the installation clearance (see drawing C). Do not put the indoor unit where there is direct sunlight on unit. The location is suitable for piping and drainage and it must be have a large distance between a door and unit.

CEILING CONCEALED MOUNTING

- Use the hanger supplied with the unit.
- Make sure that the wall is sufficiently strong to withstand the weight.

Center distance of axle (see drawing below)

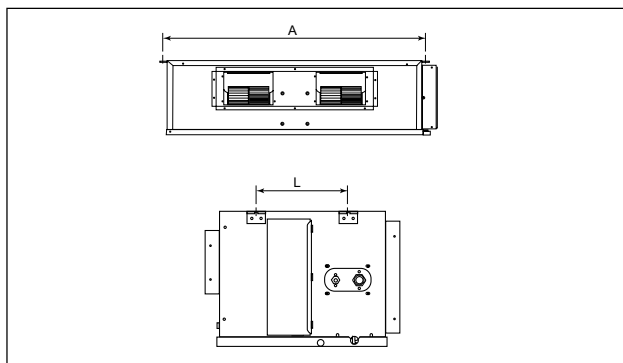

CC	A	L
10 C/CR	741	225
15 C/CR	881	225
20 C/CR	1041	225
25 C/CR	1176	225
30 C/CR	956	266
40 C/CR	1076	266
50 C/CR	1326	266
60 C/CR	1526	266

Provide clearance for servicing ease and optimal air flow as shown in the diagram.

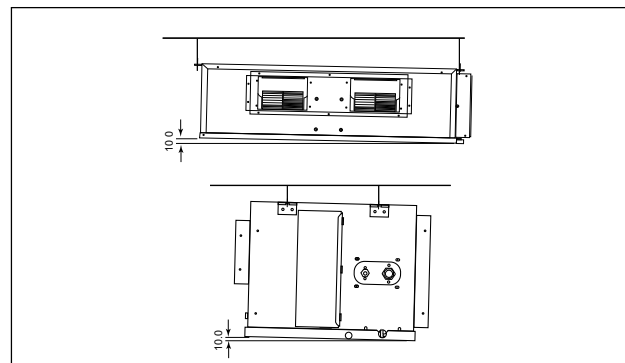

1-5



INSTALLATION OF THE OUTDOOR UNIT

The outdoor unit must be installed such that there is no short circuit of the air discharge air or obstruction to smooth air flow. Respect the installation clearance show on the table. Select the coolest possible place where intake air should not be higher than the outside temperature (maximum 45°C). Ensure that there are no obstruction of air flow into or out of the unit. Remove obstacles which block air intake or discharge.

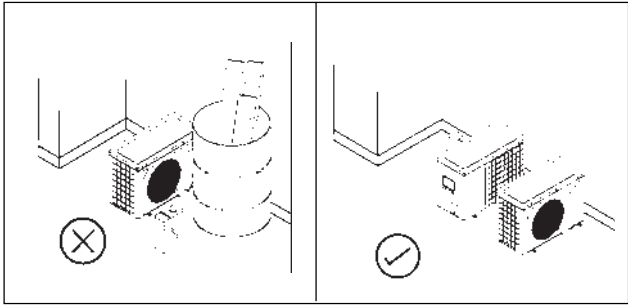
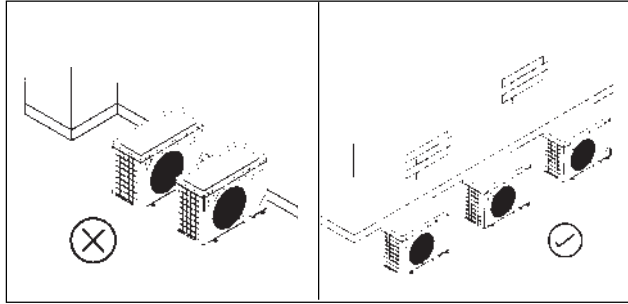

The location must be well-ventilated, so that the unit can draw in and distribute plenty of air thus lowering the temperature.

A place capable of bearing the weight of the outdoor unit as well as isolating noise and vibration.

A place protected from the direct sunlight. Use an awning for protection if necessary.

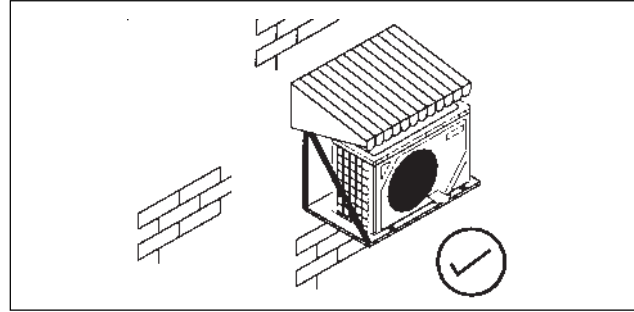

The installation location must not be susceptible to highly concentrated dust, oil, salt or sulfide gas.

Outdoor unit SL series Clearance

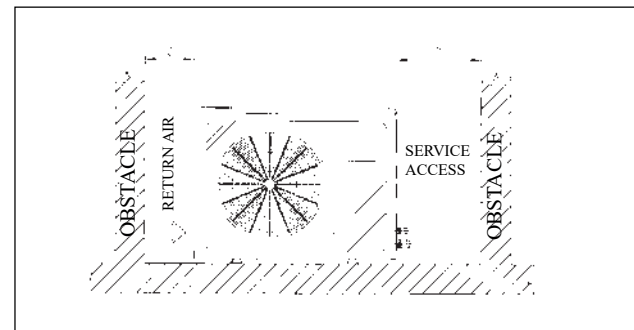
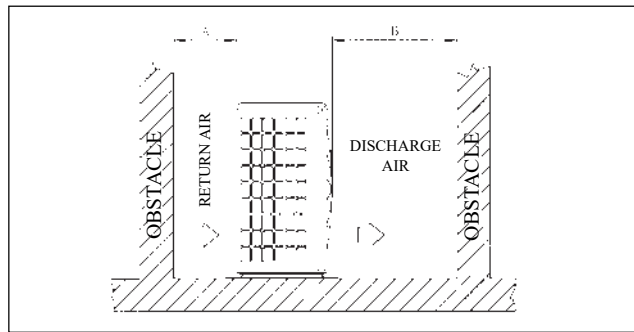

Note:- If the obstacle is higher than 2m or if there is any obstruction at the upper part of the unit allow more space than indicated in the table above.



REFRIGERANT PIPING

MAXIMUM PIPE LENGTH AND MAXIMUM NUMBER OF BENDS

When the pipe length becomes too long, both the capacity and reliability drop. As the number of bends increases, system piping resistance to the refrigerant flow increases, thus lowering the cooling capacity. As a result, compressor reliability will be affected. Always choose the shortest path and follow the recommendation as tabulated below:

Data	Model	10	15	20	25
Maximum Length (m)		7	10	15	15
Maximum Elevation (m)		5	5	8	8
Maximum No. of Bends (m)		10	10	10	10

Data	Model	30	40	50	60
Maximum Length (m)		20	20	20	20
Maximum Elevation (m)		10	10	10	10
Maximum No. of Bends (m)		10	10	10	8

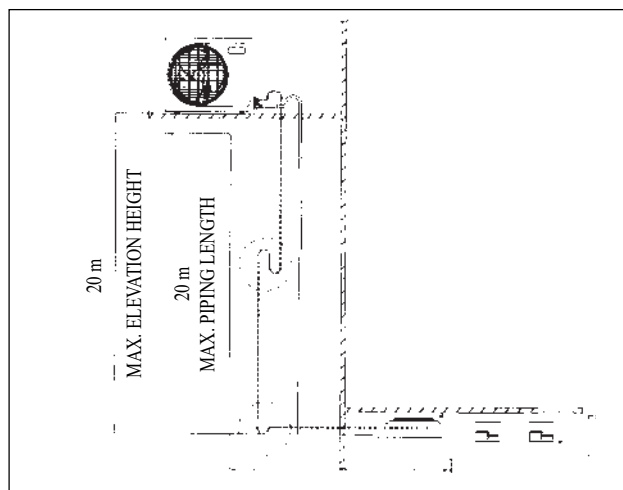
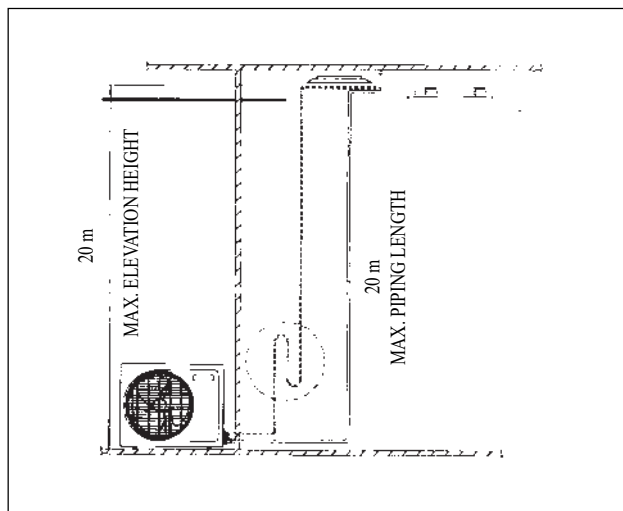

PIPING WORKS AND FLARING TECHNIQUE

Do not use contaminated or damaged copper tubing. If any piping, evaporator or condenser had been exposed or had been opened for 15 seconds or more, vacuum the system. Generally, do not remove plastic, rubber plugs and brass nuts from the valves, fittings, tubings and coils until it is ready for connection.

If any brazing work is required, ensure that the nitrogen gas is passed through piping and joints while the brazing work is being done. This will eliminate soot formation on the inside walls of the copper tubings.

Cut the pipe stage by stage, advancing the blade of pipe cutter slowly. Extra force and deep cut will cause more distortion of pipe and therefore extra burr.

Remove burrs from cut edges of pipes with a remover as shown in Fig. R. This will avoid unevenness on the flare faces which will cause gas leak. Hold the pipe on top position and burr remover at lower position to prevent metal chips from entering the pipe.

Insert the flare nuts mounted on the connection parts of both indoor and outdoor unit, into the copper pipes.

The exact length of pipe protruding from the face of the flare die is determined by the flaring tool.

Fix the pipe firmly on the flare die. Match the centers of both the flare die and the flaring punch, and tighten flaring punch fully.

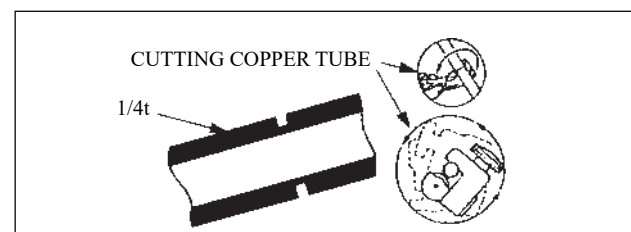
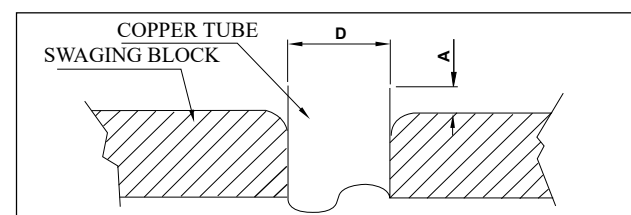
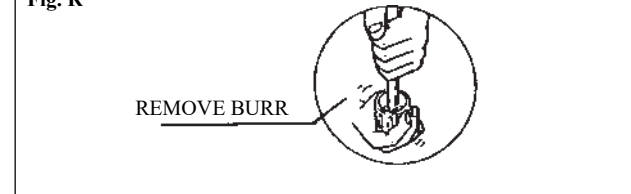

Fig. R





PIPING CONNECTION TO THE UNITS

Align the center of the piping and sufficiently tighten the flare nut with fingers.

Finally, tighten the flare nut with torque wrench until the wrench clicks.

When tightening the flare nut with the torque wrench, ensure that the direction for tightening follows the arrow on the wrench.

The refrigerant pipe connection are insulated by polyurethane (ARMAFLEX type or similar).

PIPE SIZE (mm/in)	TORQUE (Nm)
6.35 (1/4)	18
9.53 (3/8)	42
12.7 (1/2)	55
15.88 (5/8)	65
19.05 (3/4)	78

Ø TUBE		A (mm)	
INCH	mm	Imperial	Rigid
1/4"	6.35	1.3	0.7
3/8"	9.52	1.6	1.0
1/2"	12.70	1.9	1.3
5/8"	15.88	2.2	1.7
3/4"	19.05	2.5	2.0

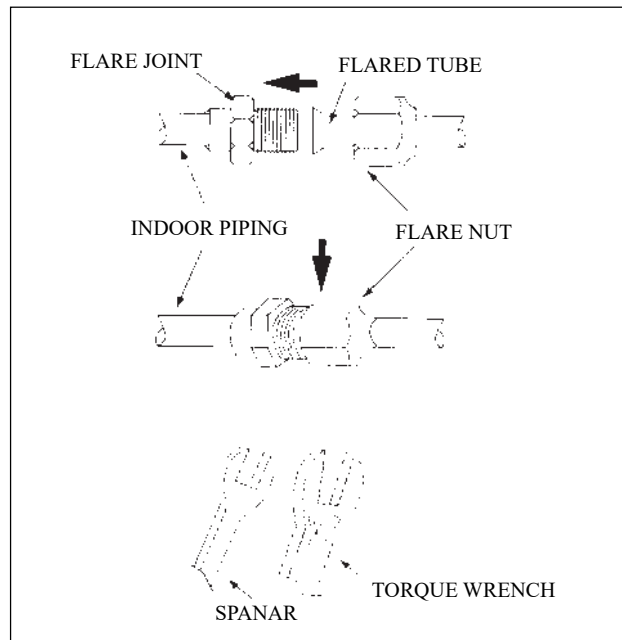

ELECTRICAL CONNECTION

Caution Ensure the color of wires of the outdoor unit and the terminal markings are same to the indoors respectively.

(Cooling only units for series 10C~25C with wire remote control & PCB)

INDOOR UNIT OUTDOOR UNIT		CC 10C SL 10B	CC 15C SL 15B	CC 20C SL 20B	CC 25C SL 25B
Voltage range		220V – 240V /1Ph /50Hz + ⊕			
Recommended fuse	A	6	10	16	20
Power Supply Cable size	mm²	1.5	1.5	2.5	2.5
Number of conductors		3	3	3	3
Interconnection Cable size	mm²	1.5	1.5	2.5	2.5
Number of conductors		3	3	3	3

IMPORTANT: These values are for information only, they should be checked and selected to comply with the local and/or national codes and regulations. They are also subjected to the type of installation and size of conductors.

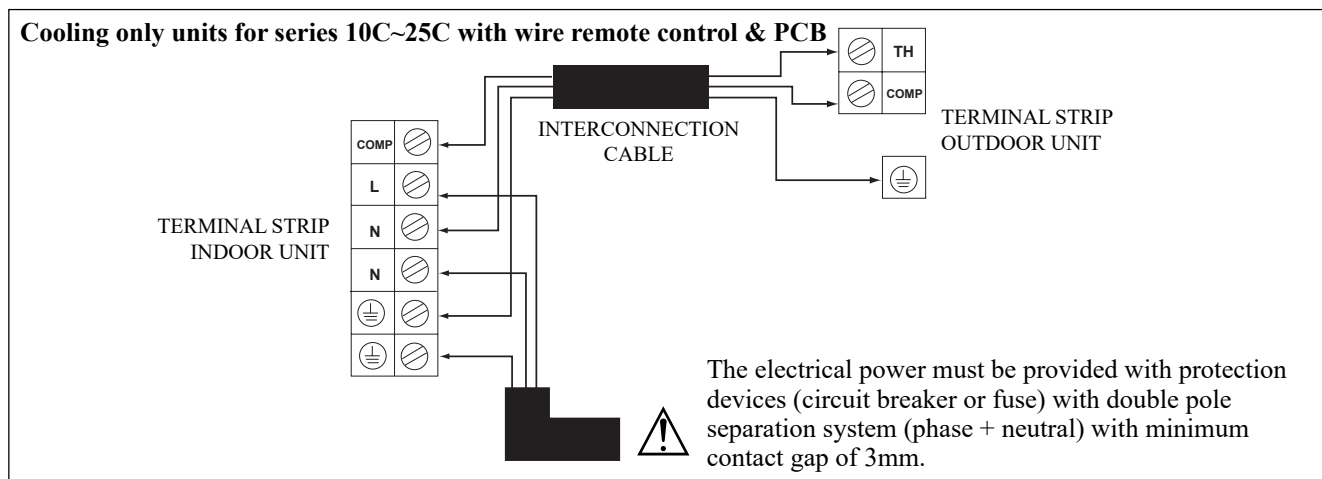



(Heat pump units for Heat pump series 10CR~25CR with wire remote control & PCB)

INDOOR UNIT OUTDOOR UNIT		CC 10CR SL 10BR	CC 15CR SL 15BR	CC 20CR SL 20BR	CC 25CR SL 25BR
Voltage range		220V – 240V /1Ph/ 50Hz + ⊕			
Recommended fuse	A	6	10	16	20
Power Supply Cable size	mm²	1.5	1.5	2.5	2.5
Number of conductors		3	3	3	3
Interconnection Cable size	mm²	1.5	1.5	2.5	2.5
Number of conductors		3	3	3	3

IMPORTANT: These values are for information only, they should be checked and selected to comply with the local and/or national codes and regulations. They are also subjected to the type of installation and size of conductors.

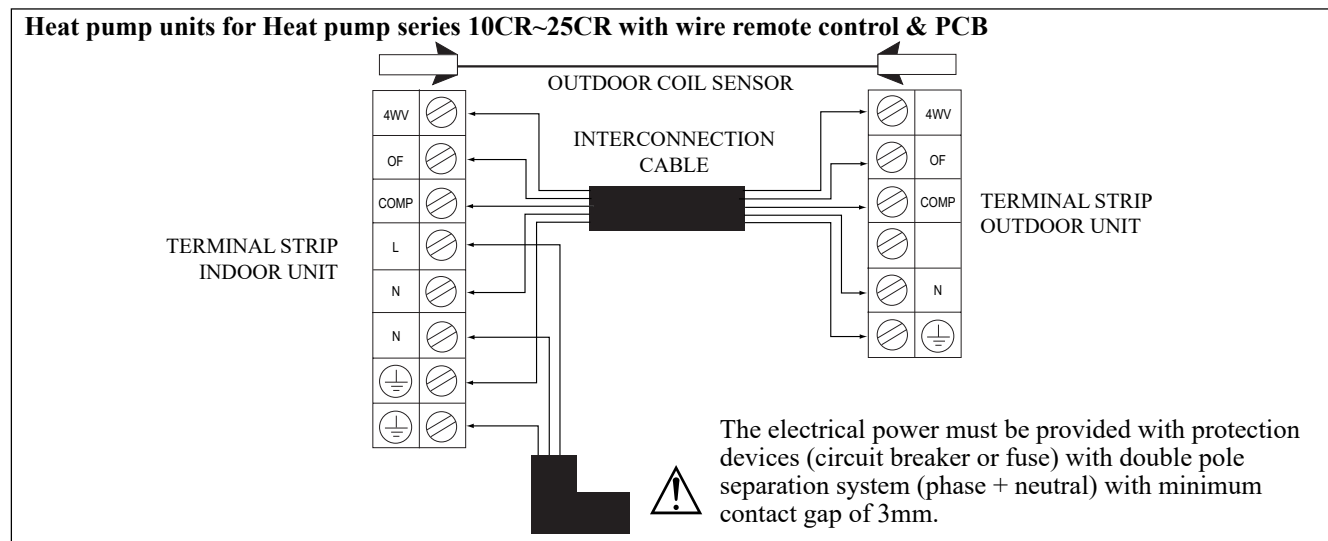

(Cooling only units for series 30C with wire remote control & PCB)

Indoor unit Outdoor unit		CC 30C SL 30C
Voltage range		220V – 240V/ 1Ph/ 50Hz + ⊕
Recommended fuse	A	25
Power Supply Cable size	mm²	4
Number of conductors		3
Interconnection Cable size	mm²	2.5
Number of conductors		7

IMPORTANT: These values are for information only, they should be checked and selected to comply with the local and/or national codes and regulations. They are also subjected to the type of installation and size of conductors used.

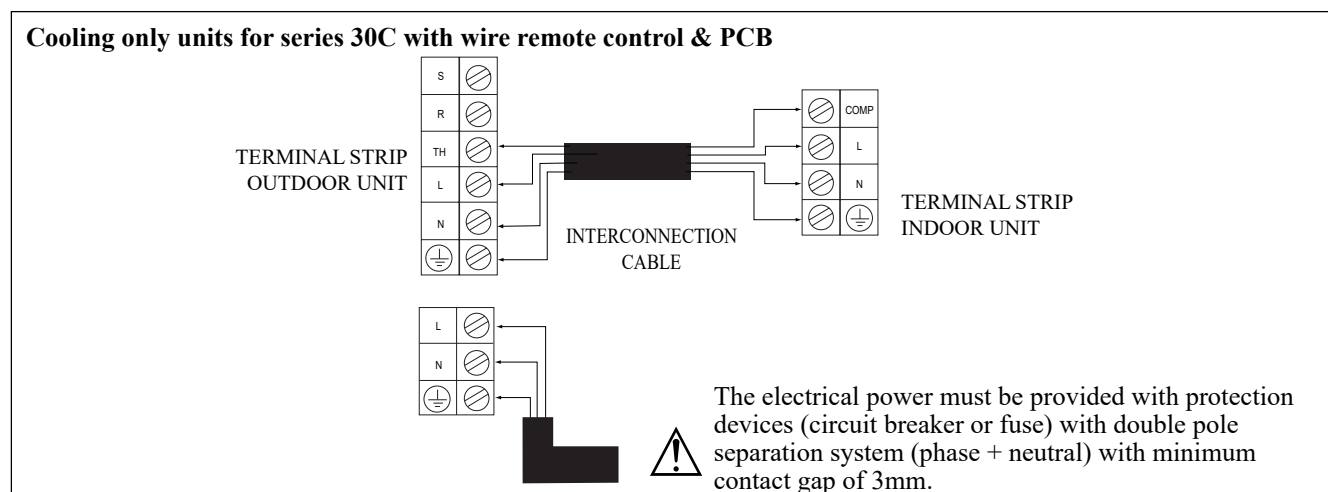



(Heat pump units for Heat pump series 30CR with wire remote control & PCB)

Indoor unit		CC 30CR
Outdoor unit		SL 30CR
Voltage range		220V – 240V /1Ph /50Hz + ⊕
Recommended fuse	A	25
Power Supply Cable size	mm²	4
Number of conductors		3
Interconnection Cable size	mm²	1.5
Number of conductors		7

IMPORTANT: These values are for information only, they should be checked and selected to comply with the local and/or national codes and regulations. They are also subjected to the type of installation and size of conductors used.

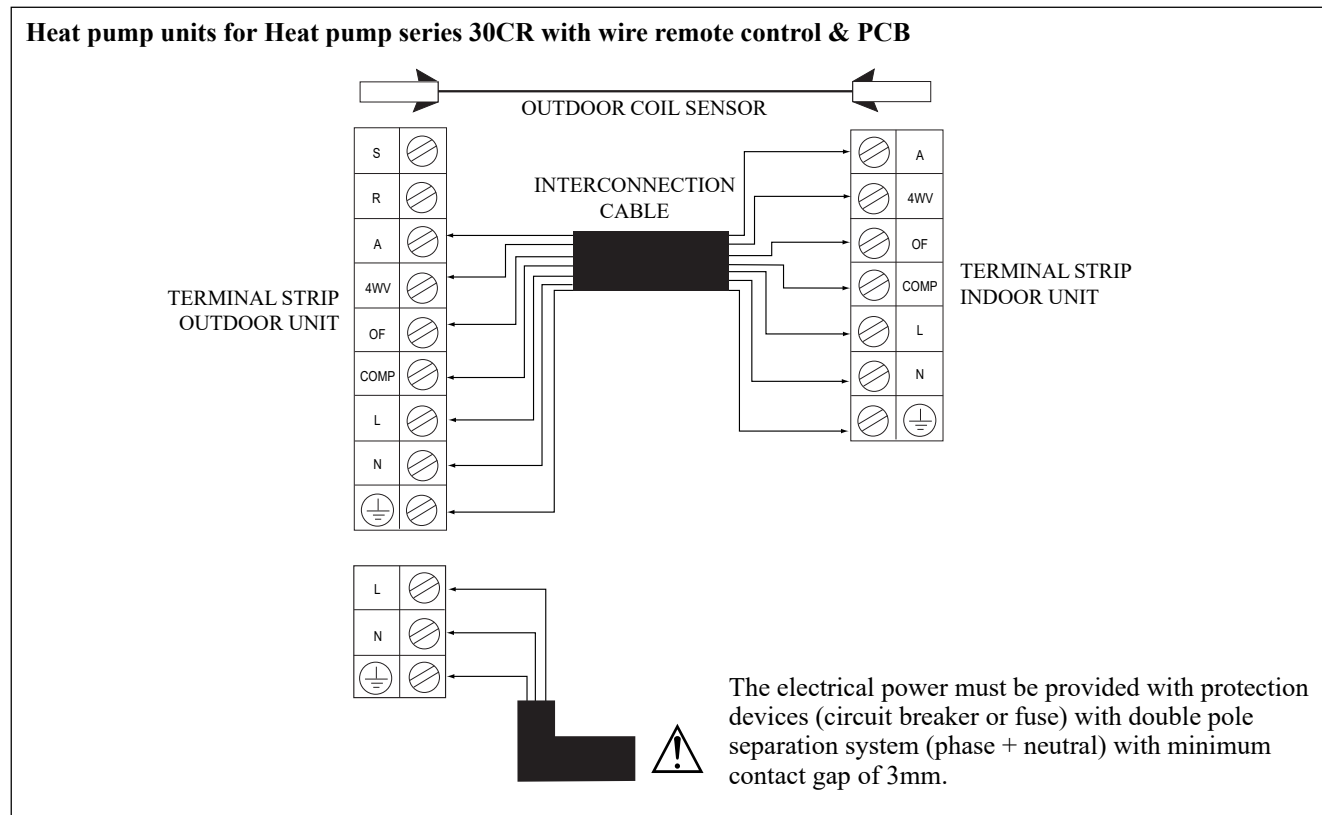

(Cooling only units for series 40C with wire remote control & PCB)

Indoor unit		CC 40C	CC 50C	CC 60C
Outdoor unit		SL 40C	SL 50C	SL 60C
Voltage range		380V– 415V/ 3Ph/ 50Hz +N + ⊕		
Recommended fuse	A	15	20	20
Power Supply Cable size	mm²	2.5	2.5	2.5
Number of conductors		4	4	4
Interconnection Cable size	mm²	1.5	1.5	1.5
Number of conductors		5	5	5

IMPORTANT: These values are for information only, they should be checked and selected to comply with the local and/or national codes and regulations. They are also subjected to the type of installation and size of conductors used.



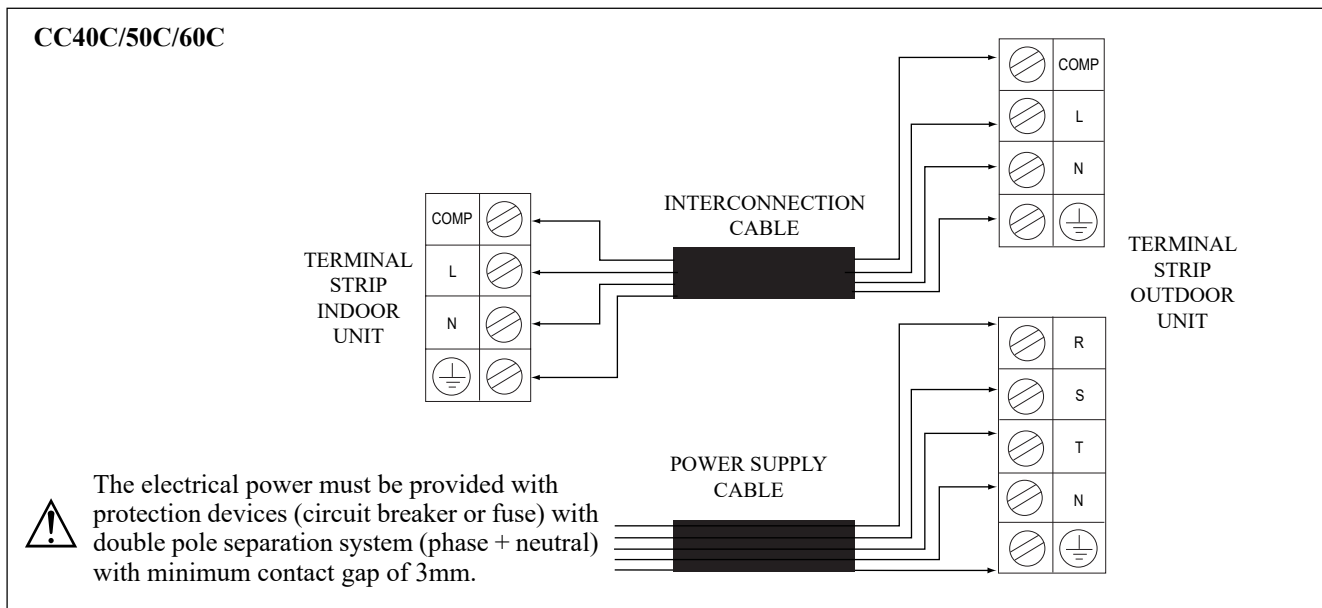

(Heat pump units for Heat pump series 40CR with wire remote control & PCB)

Indoor unit Outdoor unit		CC 40CR SL 40CR	CC 50CR SL 50CR	CC 60CR SL 60CR
Voltage range		380V–415V/ 3Ph/ 50Hz +N + ⊕		
Recommended fuse	A	15	20	20
Power Supply Cable size	mm²	4	4	4
Number of conductors		4	4	4
Interconnection Cable size	mm²	1.5	1.5	1.5
Number of conductors		7	7	7

IMPORTANT: These values are for information only, they should be checked and selected to comply with the local and/or national codes and regulations. They are also subjected to the type of installation and size of conductors used.

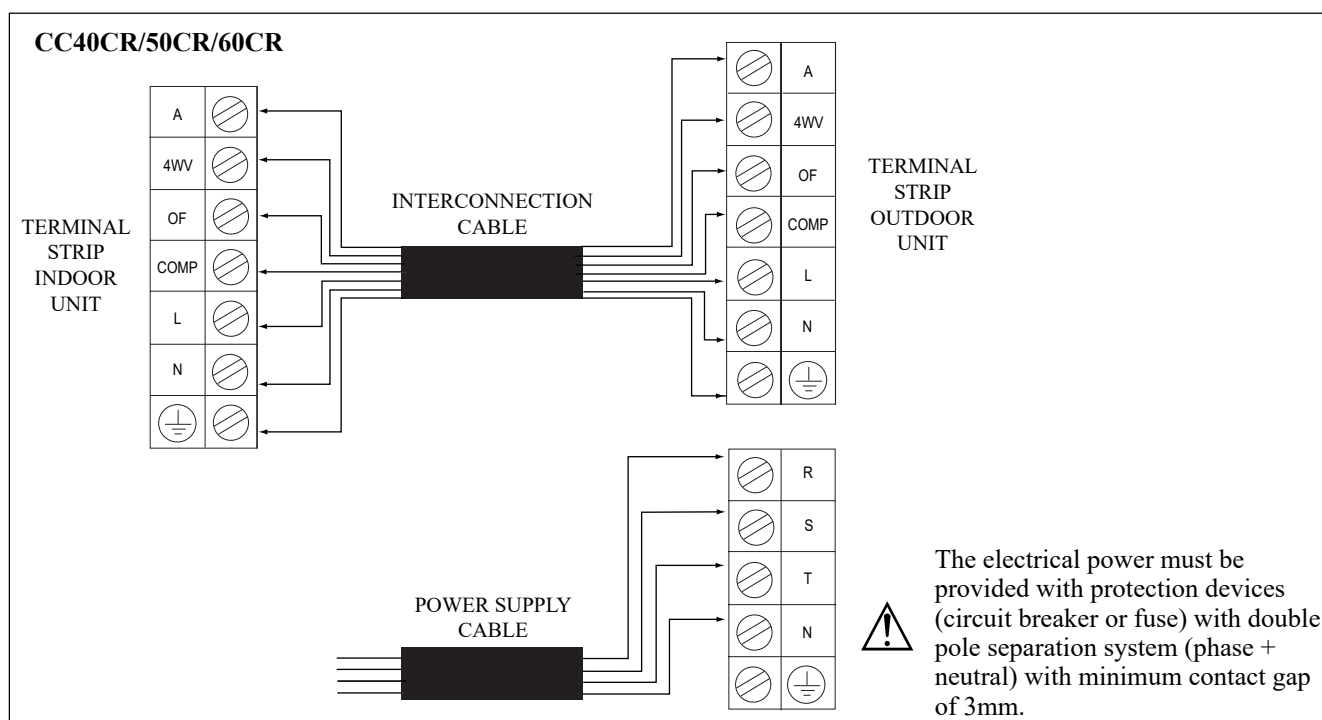

⚠ Caution

Ensure that the colors of wires on the outdoor unit and the terminal markings are the same as the indoor unit respectively.

PURGING THE REFRIGERANT PIPING

Purging the piping and the indoor unit

Except the outdoor unit which is pre-charged with refrigerant R22, the indoor unit and the refrigerant connection pipes must be air purged because the air that contain moisture remaining in the refrigerant cycle may cause malfunction to the compressor.

The outdoor unit is equipped by two 3 ways refrigerating connecting valves. The suction valve is the larger one while the small one is the liquid valve. Both valves are supplied with service port valve for connection to a manometer.

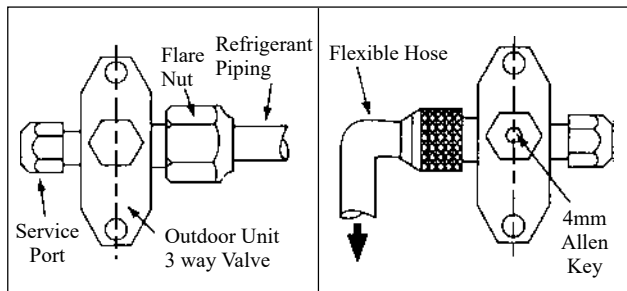

- Remove the caps from the valve and the service port.
- Connect the center manifold gauge with the vacuum pump.
- Connect the manifold gauge to the service port of the 3 ways valve.
- Start the vacuum pump. Check the low pressure manifold gauge until it indicate 0.9 bar. The evacuation time varies with each vacuum pump capacity but generally in half an hour.
- Close the manifold valve and stop the vacuum pump.
- On the outdoor unit, open the suction and liquid valve (anti clockwise) with 4mm key for hexagon sacked screw.
- The air conditioner unit is ready for start.
- If the reading is close to 0, the refrigerant circuit must be evacuated (by vacuum pump) and charged (R22) again.

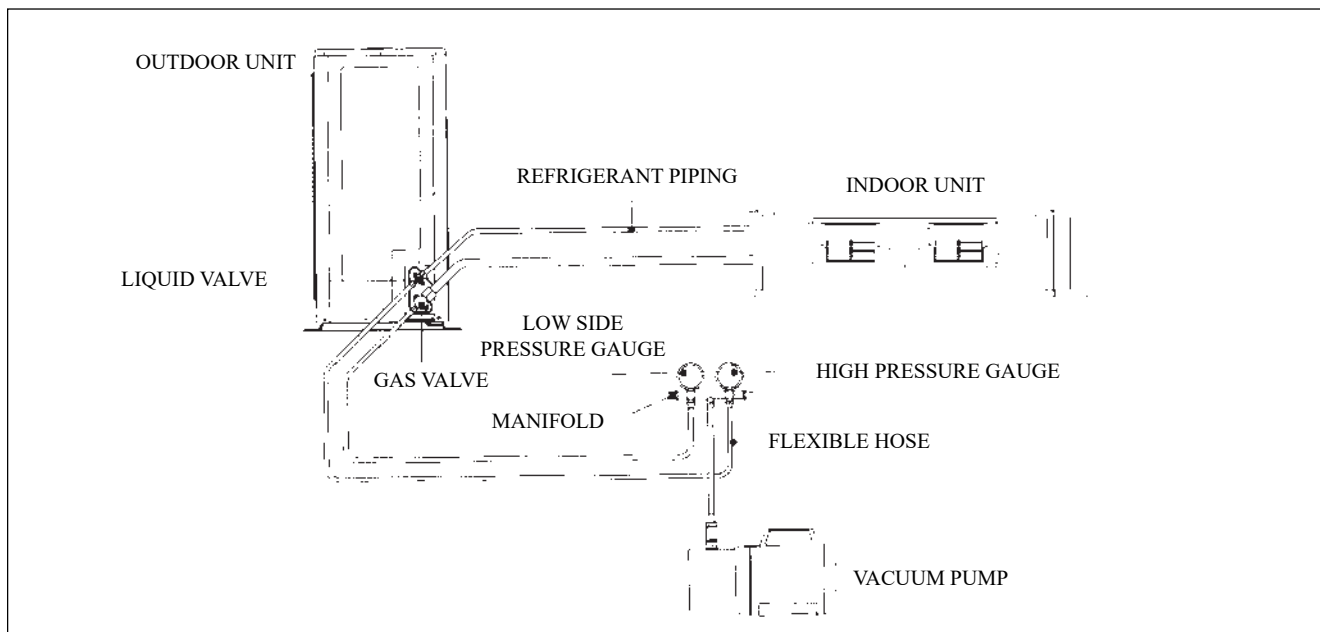



ADDITIONAL CHARGE

The refrigerant is pre-charged in the outdoor unit. If the piping length is less than 5m, additional charge after vacuuming is not necessary. When the piping length is more than 5m, use the table below.

Additional charge operation

This operation must be done by using gas cylinder and a precise weighing machine obligatorily. The additional charge is top up into the outdoor unit by suction valve via service port.

- Remove the service valve plug.
- Connect the low pressure manifold to the suction service port, center manifold to the cylinder tank and close the high pressure manifold (see figure below).
Purge all the flexible hose with refrigerant gas.
- Start the air conditioner unit.
- Open the gas cylinder and low pressure manifold valve.
- When the required refrigerant quantity is pumped in the unit, close the low pressure manifold and the gas cylinder valve.
- Disconnect the manometer and the gas cylinder. Place back the service port cap.

Cooling only unit Additional charge in gram

Model	7m	10m	15m	20m
CC10C	30	75	–	–
CC15C	30	75	–	–
CC20C	30	75	150	–
CC25C	76	190	380	–
CC30C	100	250	500	750
CC40C	100	250	500	750
CC50C	100	250	500	750
CC60C	100	250	500	750

Heat pump unit Additional charge in gram

Model	7m	10m	15m	20m
CC10CR	40	100	–	–
CC15CR	40	100	–	–
CC20CR	50	125	250	–
CC25CR	100	250	500	–
CC30CR	100	250	500	750
CC40CR	100	250	500	750
CC50CR	100	250	500	750
CC60CR	100	250	500	750

Check refrigerant leak

Check with refrigerant detector whether there is a leak on the flare type connection of the indoor unit and outdoor unit.
Hints: After operation for sometime, check if there is oil traces, there is a leak.

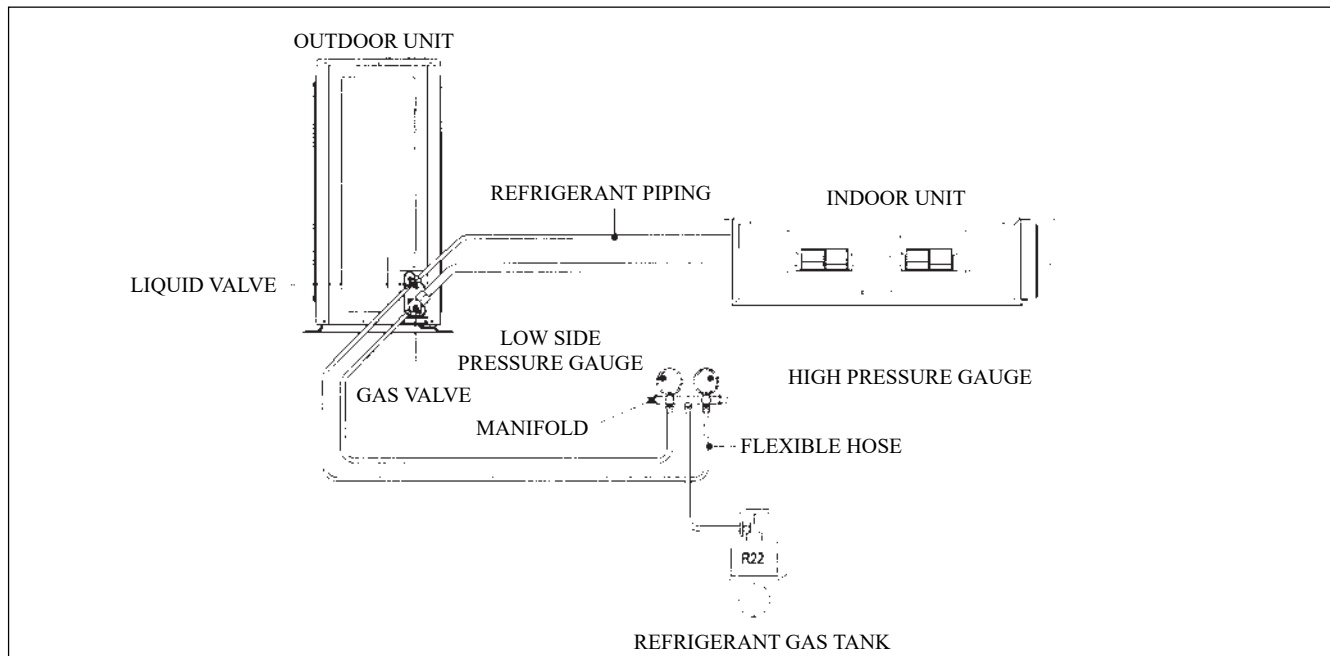



OVERALL CHECKING

Ensure the following, in particular:-

- 1) The unit is mounted solidly and rigid in position.
 - 2) Piping and connections are leak proof after charging.
 - 3) Proper wiring has been done.
- Drainage check-pour some water into left side of drain pan
(drainage are in right side of unit)

• Test run

- 1) Conduct a test run after water drainage test and gas leakage test.
- 2) Watch out for the following:-
 - a) Is the electric plug firmly inserted into the socket?
 - b) Is there any abnormal sound from unit?
 - c) Is there smooth drainage of water?

• Check that:

- 1) Condenser fan is running, with warm air blowing off the condensing unit.
- 2) Evaporator blower is running and discharge cool air.
- 3) The remote controller incorporates a 3 minute delay in the circuit. Thus, it requires about 3 minutes before the outdoor condensing unit can start up.

STANDARD OPERATING CONDITION

Cooling Only Unit

Temperature	Ts °C	Th°C
minimum indoor temperature	16	11
maximum indoor temperature	32	23
minimum outdoor temperature	16	11
maximum outdoor temperature	43	26

Heat Pump Unit

Temperature	Ts °C	Th°C
minimum indoor temperature	16	–
maximum indoor temperature	30	–
minimum outdoor temperature	–5	–6
maximum outdoor temperature	24	18

Ts: Dry bulb temperature.

Th: Wet bulb temperature.



Warning

- Disconnect from the main power supply before servicing the air conditioner unit.
- DO NOT pull out the power cord when the power is ON. This may cause serious electrical shocks which may result in fire hazards.

AUTO RANDOM RE-START FUNCTION

If there is a power cut when the unit is operating, it will automatically resume the same operating mode when the power is restored. (Applicable only to units with this feature)

Caution

Before turning off the power supply, set the remote controller's ON/OFF switch to the "OFF" position to prevent the nuisance tripping of the unit.

If this is not done, the unit's fans will start turning automatically when power resumes, posing a hazard to service personnel or the user.

SERVICE AND MAINTENANCE

SERVICE PARTS	MAINTENANCE PROCEDURES	PERIOD
Indoor air filter	<ol style="list-style-type: none"> 1. Remove any dust adhered on the filter by using a vacuum cleaner or wash in lukewarm water (below 40°C) with neutral cleaning detergent. 2. Rinse well and dry the filter before placing it back onto the unit. 3. Do not use gasoline, volatile substances or chemical to clean the filter. 	<p>At least once every 2 week.</p> <p>More frequently if necessary.</p>
Indoor unit	<ol style="list-style-type: none"> 1. Clean any dirt or dust on the grille or panel by wiping it using soft cloth soaked in lukewarm water (below 40°C) with neutral detergent solution. 2. Do not use gasoline, volatile substances or chemical to clean the indoor unit. 	<p>At least once every 2 weeks.</p> <p>More frequently if necessary.</p>
Condense drain pan & pipe	<ol style="list-style-type: none"> 1. Check its cleanliness and clean it if necessary. 	Every 3 months.
Indoor fan	<ol style="list-style-type: none"> 1. Check for any abnormal noise. 	When necessary.
Indoor/outdoor coil	<ol style="list-style-type: none"> 1. Check and remove any dirt clogged between the fins. 2. Check and remove any obstacles that hinder air flowing into and out of the indoor/outdoor unit. 	<p>Every month.</p> <p>Every month.</p>
Power supply	<ol style="list-style-type: none"> 1. Check the voltage and current of the indoor and outdoor unit. 2. Check the electrical wiring for any faulty contacts caused by loose connections, foreign matters, etc. Tighten the wires onto the terminal block if necessary. 	<p>Every 2 months.</p> <p>Every 2 months.</p>
Compressor	<ol style="list-style-type: none"> 1. No maintenance needed if the refrigerant circuit remain sealed. However, check for any refrigerant leaks at all joints and fitting. 	Every 6 months.
Compressor oil	<ol style="list-style-type: none"> 1. The compressor oil is factory-precharged. It is not necessary to add any oil if the circuit remains sealed. 	No maintenance required.
Fan motor oil	<ol style="list-style-type: none"> 1. All motor pre-lubricated and sealed at factory. 	No maintenance required.



Caution

Do not operate any heating apparatus too close to the air conditioner unit. This may cause the plastic panel to melt or deform as a result of the excessive heat.

TROUBLE SHOOTING

When any malfunction of the air conditioner unit is noted, immediately switch off the power supply to the unit. Check the following fault conditions and causes for some simple trouble shooting tips.

FAULT	CAUSES
1. The compressor does not start operate after 3 minutes from starting the air conditioner unit.	- Protection against frequent starting. Wait for 3 to 4 minutes for the compressor to start operate.
2. The air conditioner unit does not operate.	- Power failure, or the fuse need to be replaced. - The power plug is disconnected. - It is possible that your delay timer has been set incorrectly. - If the fault persist after all these verifications, please contact the air conditioner unit installer.
3. The air flow is too low.	- The air filter is dirty. - The doors or windows are open. - The air suction and discharge are clogged. - The regulated temperature is not high enough.
4. The remote control display is dim.	- Battery flat. - The batteries are placed incorrectly.
5. Discharge air flow has bad odor.	- Odors may be caused by cigarettes, smoke particles, perfume etc. which might have adhered onto the coil.
6. Condensation on the front air grille of the indoor unit.	- This is caused by air humidity after an extended long period of operation. - The set temperature is too low, increase the temperature setting and operate the unit at high fan speed.
7. Water flowing out from the air conditioner unit.	- Check the condensate evacuation.
8. Hissing air flow sound from the air conditioner unit during operation.	- Refrigerant fluid flowing into the evaporator coil.

If the fault persists, please call your local dealer / serviceman.