



# TECHNICAL MANUAL



# BOILER MANAGEMENT SYSTEM QETERM-01



# CONTENTS

1	GENERAL FEATURES .....	4
2	FRONT CONTROL PANEL.....	5
3	BOILER MANAGEMENT SYSTEM.....	6
4	SPECIFICATIONS.....	7
5	ASSEMBLY .....	10
6	TERMINAL BLOCK FOR ELECTRIC CONNECTIONS.....	11
7	MODEM (OPTIONAL) .....	12
8	WIRING DIAGRAM .....	14
8	USING BURNER OR 0-10 VOLT MIXING VALVE .....	19
9	USING THE MIXING VALVE WITH THREE POINTS 230 VAC.....	19

# 1 GENERAL FEATURES

## **Standard equipment:**

Main switch  
Switch operation of the burner Manual 0 Automatic  
Dual thermostat adjustment ISPESEL  
Safety thermostat ISPESEL  
Thermometer  
Electronic board with Microprocessor  
Boiler sensor

## **Main Features:**

Burner management single stage - two stages - three stages  
Burner management two stage progressive  
Management modulating burner control with three-points  
Modulating burner management command 0-10 Volt  
Temperature regulation of the flow delivery temperature (with optional external probe)  
2 programmable outputs for circulators configurable for:  
    Management of the cylinder (with thermostat or optional probe)  
    Management of boiler circulator  
    Management circulating system forward zone  
    Management of the circulator mixed zone  
    Management of the circulator cascade head  
1 input for boiler sensor  
2 programmable inputs configurable for:  
    Probe input PT1000  
    Digital input  
1 programmable input designed for:  
    NTC probe input  
    Digital input  
Management mixing valve with control 0 -10 Volt  
(if modulating burner with control 0 -10 Volt is not provided)  
Valve control with three-points  
(If a single-stage or modulating burner with control 0 -10 Volt is provided)  
1 input 0-10 Volt programmable for:  
    Digital control  
    Modulation of boiler temperature  
    Showing 0-10 Volt transducers (eg., CO2 sensor)  
Cascade management (with function as master or slave)  
Pump anti-lock function  
Antifreeze protection

## **Optional**

External probe  
Flue probe  
PT1000 probe with immersion (cylinder - plant - mixing area)  
PT1000 probe with contact (plant - mixing area)  
Modem with built-in antenna  
Modem with 10m antenna extension.

## 2 FRONT CONTROL PANEL

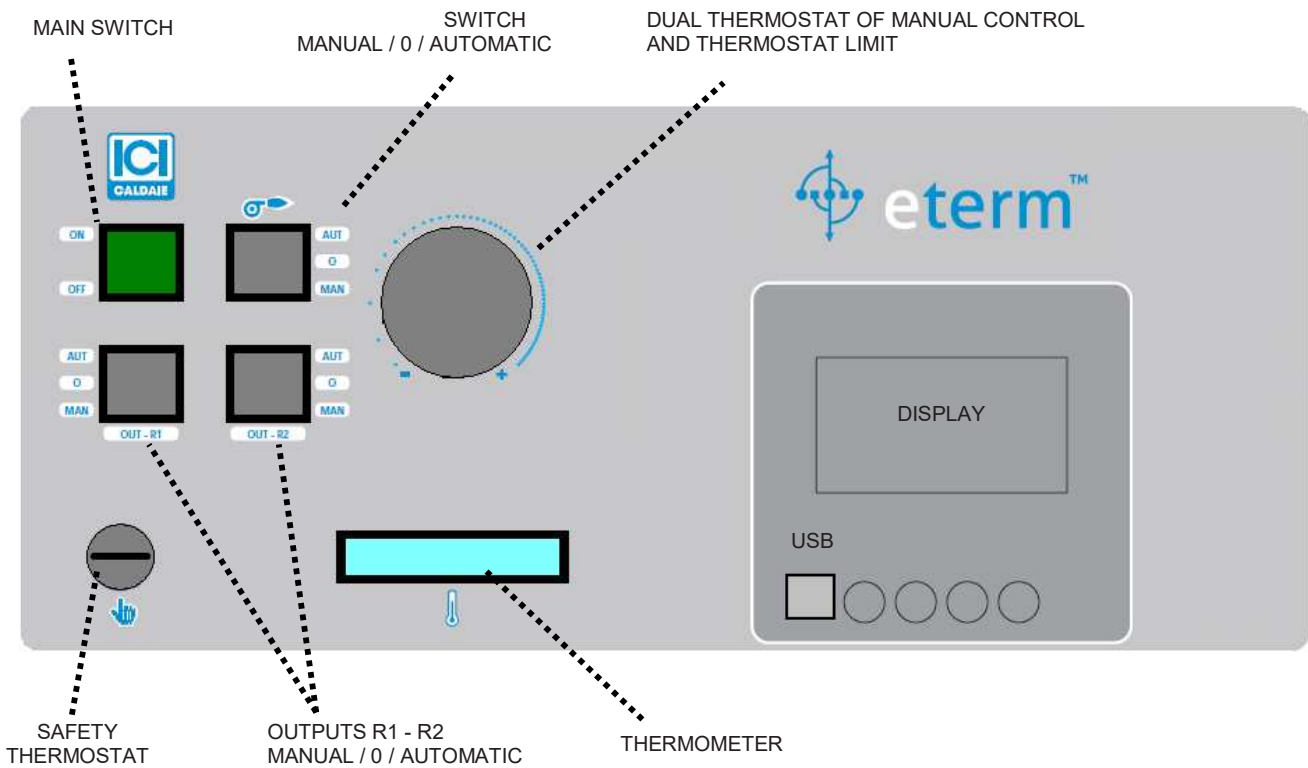

**FOR SETUP AND OPERATION OF ELECTRIC BOARD  
SEE SPECIFIC MANUAL**

### 3 BOILER MANAGEMENT SYSTEM

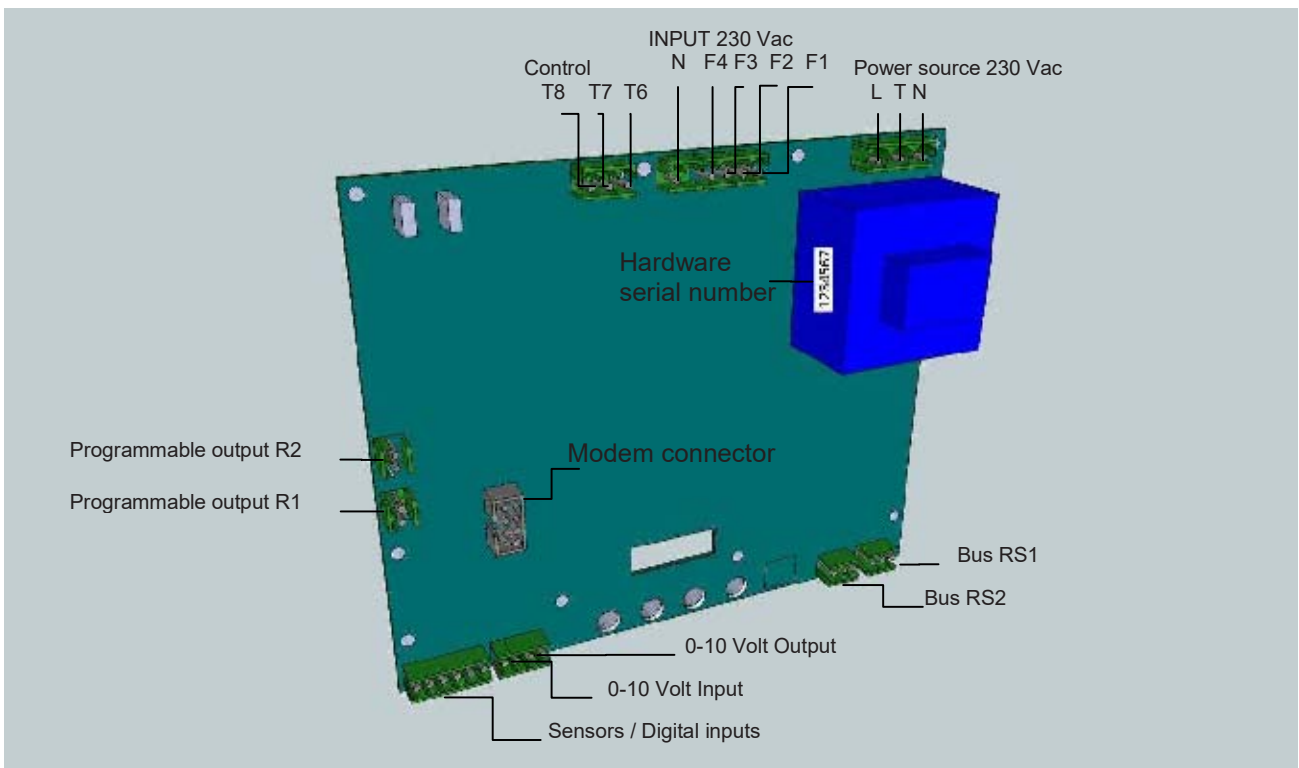
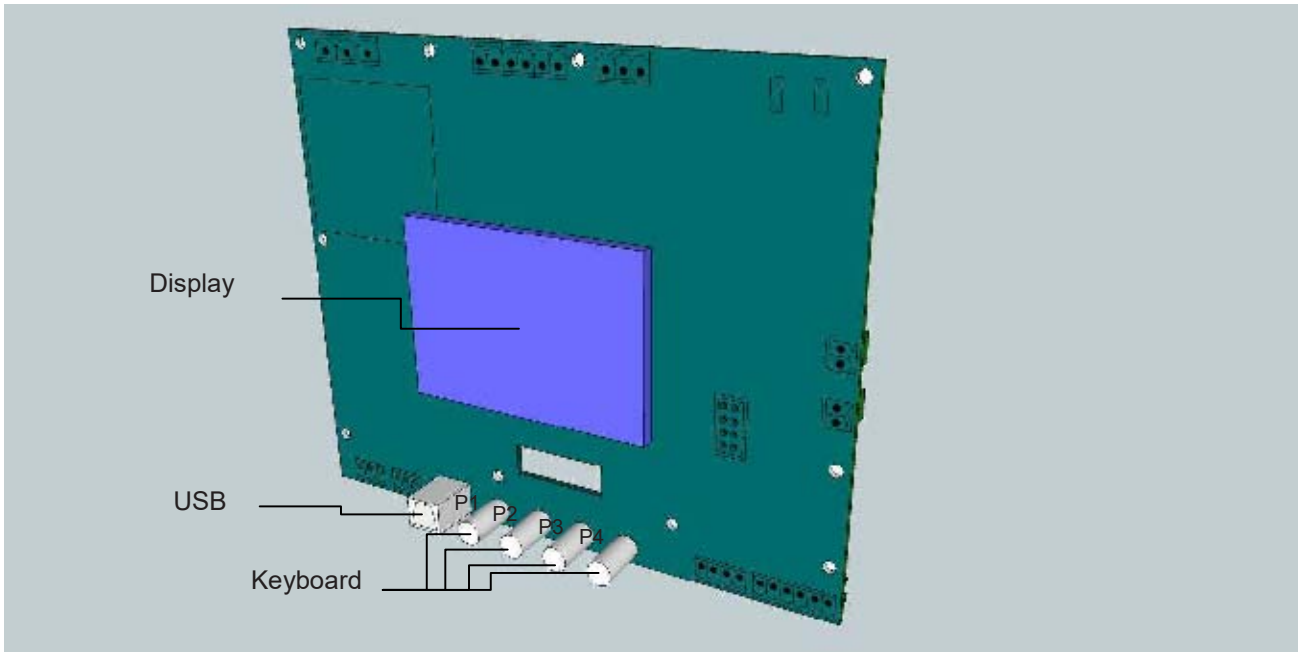

**FOR SETUP AND OPERATION OF ELECTRONIC SYSTEM  
SEE SPECIFIC MANUAL**

## 4 SPECIFICATIONS

### POWER SOURCE

L T N 230 Vac

### OPTO-ISOLATED INPUTS

**F1** Programmable input provided by:

Safety intervention signals (when they are not lit it means that the safeties are on)

**F2** Programmable input provided for:

Modulating burners, when there is tension it means that the burner is turned on (standard burner plug B4)

Two-stage burner, when there is tension it means that the burner is on at primary flame (standard burner plug B4)

**F3** Programmable input provided for:

Two-stage burner, when there is tension it means that the burner is on at second flame (burner standard plug B4)

**F4** Programmable input provided for:

For each type of burner, when it is on it means that the burner is fault (standard burner plug S3)

### CONSENT FOR OUTPUT / BURNER MODULATION

**T1-T2** Contact consent for burner start up (standard burner plug T1-T2)

Maximum load 230 Vac / 6.5 A

**T6-T7 / T6-T8** Contacts burner modulations / mixing valves

Maximum load 230 Vac / 1 A

For single-stage burners:

Contacts not used

Two-stage burner:

Main flame T6-T7 closed - T6-T8 open

Second flame T6-T7 closed - T6-T8 closed

For progressive burners:

Main flame T6-T7 closed - T6-T8 open

Second flame T6-T7 open - T6-T8 closed

For modulating burners:

Linear decrease of power - T6-T7 closed - T6-T8 open

Linear increase of power - T6-T7 open - T6-T8 closed

Steady state power - T6-T7 open - T6-T8 open

For burners with three stages:

Main flame - T6-T7 open - T6-T8 open (T1-T2 closed)

Second flame - ended T6-T7 - T6-T8 open

Third flame - T6-T7 closed - T6-T8 closed

**If there is a single-stage or modulating burner with a 0-10 Volt signal**, T6-T7-T8 can be used to control a mixing valve actuator with three points.

Linear closure of the valve - T6-T7 closed - T6-T8 open

Linear opening of the valve - T6-T7 open - T6-T8 closed

Steady opening - T6-T7 open - T6-T8 open

If the mixing valve is in service for a system with a floor, an external security system is provided to prevent the circulation of water that is too hot, in case of a malfunction and/or power failure to the system.

## PROGRAMMABLE OUTPUTS

**R1 - R2** Programmable Outputs  
Maximum load 230 Vac / 2 A

The various programmable outputs can be configured for  
Boiler pump consent  
Header pump consent (for cascade)  
System pump consent  
Cylinder pump consent

## SENSOR INPUTS - DIGITAL

**PT1** Input PT 1000 provided for the boiler probe  
**PT2** Programmable input PT 1000 / Digital  
**PT3** Programmable input PT 1000 / Digital  
**NTC** Programmable input NTC / Digital

The various programmable inputs can be configured for the  
Cylinder sensor  
Header sensor (for cascade)  
Flow sensor system  
Return sensor  
Flue probe  
Tank thermostat - free contact  
External sensor (NTC)  
Control for climate operation or with set point  
INPUT 0-10 Volt / DIGITAL  
Programmable input configurable for:  
Modulation of boiler temperature  
Modulation of header temperature (for cascade)  
Control for climate operation or with set point  
CO2 sensor  
Other inputs from transducers 0-10 Volt  
OUTPUT 0-10 Volt  
Programmable output configurable for:  
Mixing valve system control  
Burner modulation control

## COMMUNICATION

Modem connector  
USB socket

**RS1** - Connection RS485 for connecting the system via bus to its own Master (other boiler system or MASTER NEREIX)

**RS2** - Connection RS485 for connecting the system via bus to its own slaves (other boiler systems or system management boards)

The boiler board can work alone to control a single burner; in this case, it can be directly connected to a modem for remote management.

More boiler boards (maximum 16) can be connected together using a special bus connection; in this case one of the boards will be set as Master and it can be connected to the modem.

If the system has a Nereix Master board, it can be connected to a boiler board with special input; in this case the boiler board will become a slave like a satellite use module NEREIX.

If there are more boards in cascade, the Master Nereix will be connected to the boiler board that will be set as Master.

The board management system can be a slave of the boiler board or the Master Nereix board



## BUS BETWEEN BOILERS IN CASCADE

Use shielded cable 2 x 0.35 mm<sup>2</sup> for connecting the bus.

The RS1 C contact (corresponding to terminal 34) is only for support of the cable shield; it is not necessary to connect it to the last slave.

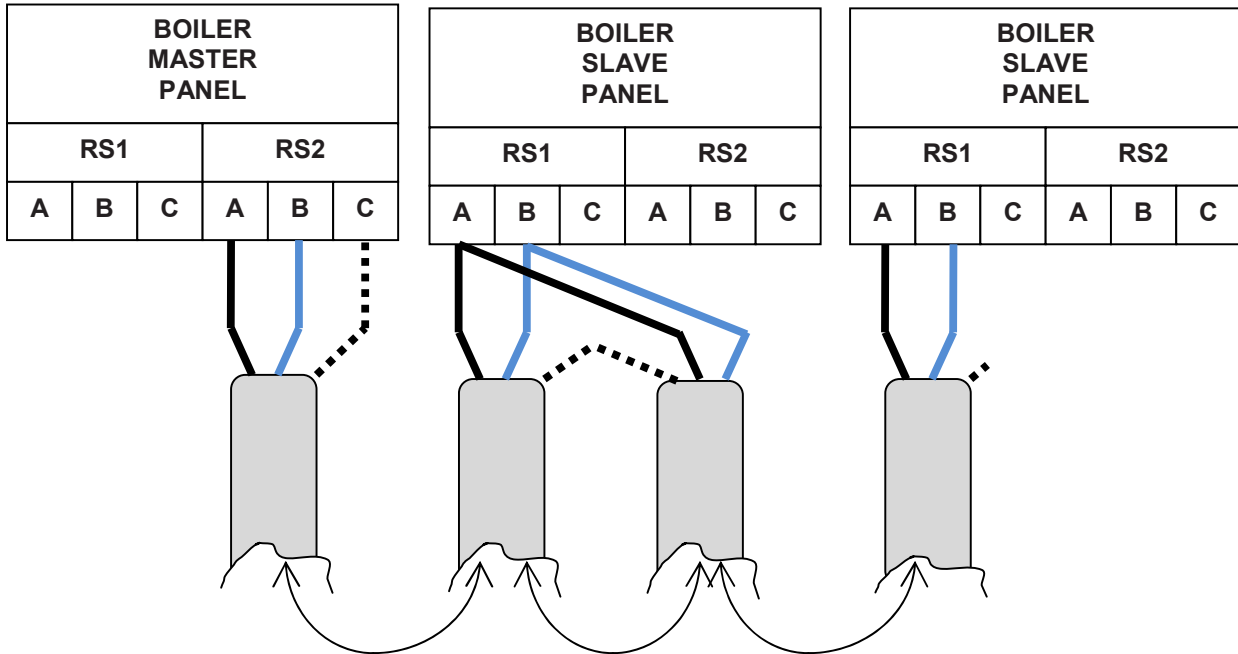

## BUS BETWEEN NEREIX MASTER AND BOILER IN CASCADE

The RS1 C contact (corresponding to terminal 34) is only for support of the cable shield; it is not necessary to connect it to the last slave.

In wiring the slave boards there must be continuity between the shields.

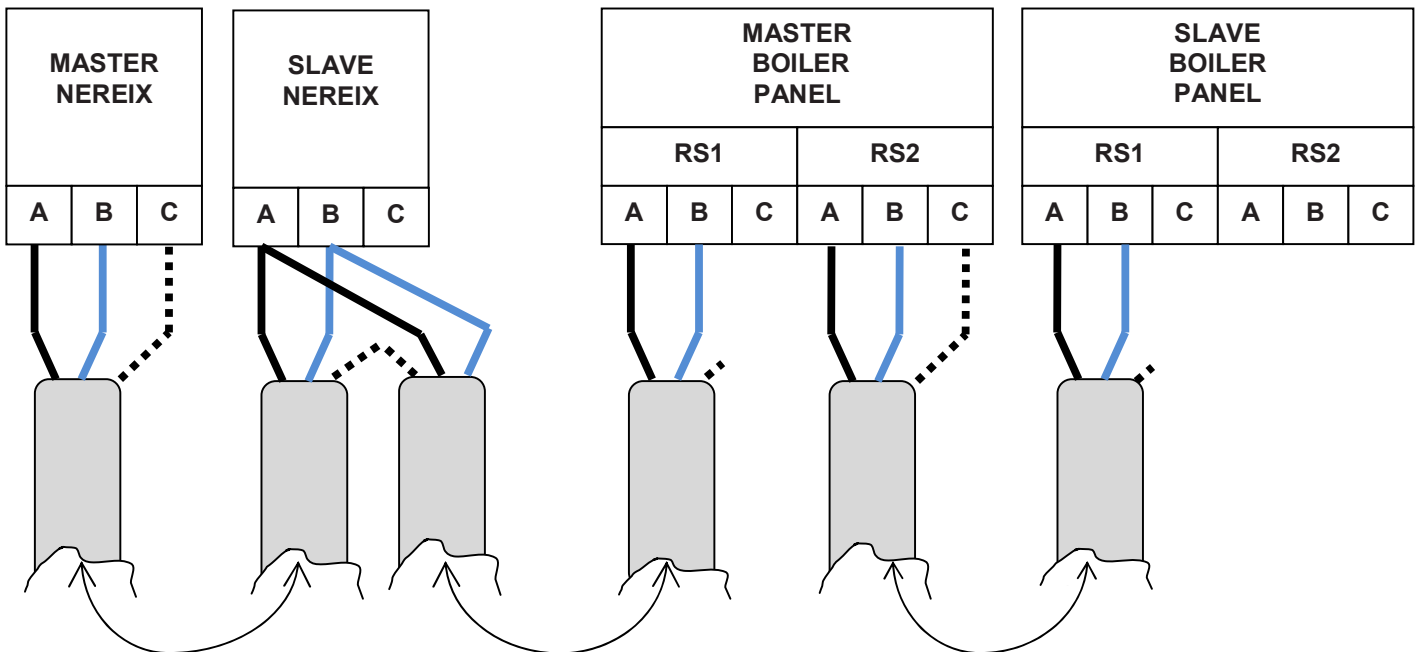

## 5 ASSEMBLY



ALL THE OPERATIONS OF INSTALLATION AND WIRING MUST BE CARRIED OUT WHEN THE ELECTRICITY IS DISCONNECTED

Remove the screws that are set on the bottom of the front and open it.



The panel, depending on the boiler model, can be set at the top or vertically on the casing.

Set the panel using the holes on the casing of the boiler and in the panel itself.

Make the capillaries of the thermostats and thermometers exit to the back or down depending on the type of assembly (above or beside the boiler) - for this purpose if necessary move the locking plate assembled on the bottom of the panel.

Remove the pre-cut backs and/ or sides to mount the passage press cables necessary.

Connect the wires to the removable terminals according to what is stated in the section "TERMINAL BLOCK FOR ELECTRIC CONNECTIONS".

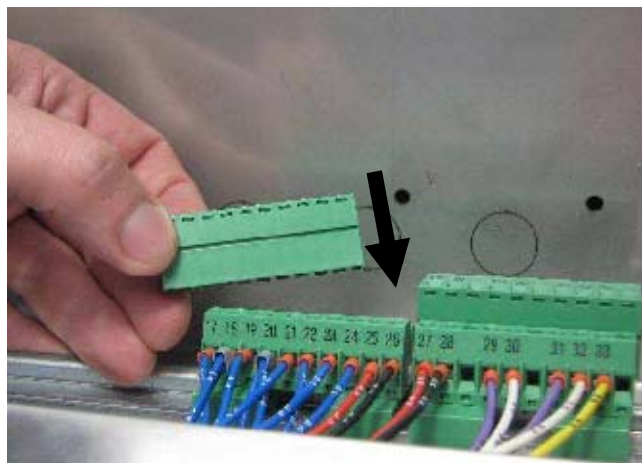

Replace the removable terminals wired to the male couplings mounted inside the cabinet on the DIN bar.

Respect any polarity

**The assembly and connections are done with the electrical power off.**

Close the panel and replace the screws.

## 6 TERMINAL BLOCK FOR ELECTRIC CONNECTIONS

TERMINAL NAME	FUNCTION	TERMINAL TYPE	
<b>HIGH VOLTAGE</b>			
L	GENERAL POWER SUPPLY PANEL	L	10 POLE TERMINAL BLOCK
T		T	
N		N	
1	EXTERNAL SAFETIES (INSERT STANDARD BRIDGE)	IN	
2		OUT	
3	BURNER POWER	L	
T		T	
4		N	
5	BURNER CONSENT (T1-T2) *	T1	
6		T2	
7	FIRST STAGE SIGNAL	B4	6 POLE TERMINAL BLOCK
8	SECOND STAGE SIGNAL	B5	
9	FAULT SIGNAL	S3	
10	MODULATION OF BURNER OR MIXING VALVE	T6	
11		T7	
12		T8	
13	PUMP 1 (R1) *	L	4 POLE TERMINAL BLOCK
14		N	
15	PUMP 2 (R2) *	L	
16		N	
<b>OUTPUTS T1-T2, T6-T7, T6-T8 ARE MADE WITH TRIAC; TO ACTIVATE THE CONTACT THERE MUST BE AT LEAST 24 Vac BETWEEN THE ENDS THEN USE THE CONTACTS TO CONTROL UTILISERS AND / OR AUXILIARY POWER WITH AT LEAST 24 Vac UP TO 230 Vac</b>			
<b>LOW VOLTAGE / SIGNAL</b>			
17	PT1 – Boyler probe (PT1000)	1	10 POLE TERMINAL BLOCK
18		2	
19	PT2	1	
20		2	
21	PT3	1	
22		2	
23	NTC	1	
24		2	
25	IN 0-10 V	+	
26		-	
27	OUT 0-10 V	+	10 POLE TERMINAL BLOCK
28		-	
<b>Not Connected</b>			
29	485 (RS1)	A	
30		B	
<b>Not Connected</b>			
31	485 (RS2)	A	
32		B	
33		C	
<b>Not Connected</b>			

## 7 MODEM (OPTIONAL)



**ALL THE OPERATIONS OF ASSEMBLY AND WIRING MUST BE CARRIED OUT WHEN THE ELECTRICITY IS OFF**

### GENERAL FEATURES OF THE MODEM

The modem, through the flat, is powered directly by the board.  
Turn off the power when connecting the modem and when inserting the SIM card.  
The SIM card must be enabled for data traffic (not voice!).  
The SIM must be pushed all the way in: a click will result when the insertion is done.  
Before inserting the SIM, disable the PIN using a cellular phone.

Main features:

- GSM Modem Module - Quad-Band GPRS
- LED status registers on the GSM network
- Buzzer for acoustic signaling
- TTL Interface
- Compatible with Master NEREIX board

### RADIO FEATURES

- Quad-band EGSM 850/900/1800/1900 MHz
- Power of emission:
- Class 4 (2W) @ 850/900 MHz
- Class 1 (1W) @ 1800/1900 MHz
- Sensitivity:
- 107 dBm (type) @ 850/900 MHz
- 106 dBm (type) @ 1800/1900 MHz

### FEATURES GPRS

- GPRS class 10
- Mobile station class B
- Coding layouts: by 1 to 4
- Support PBCCH

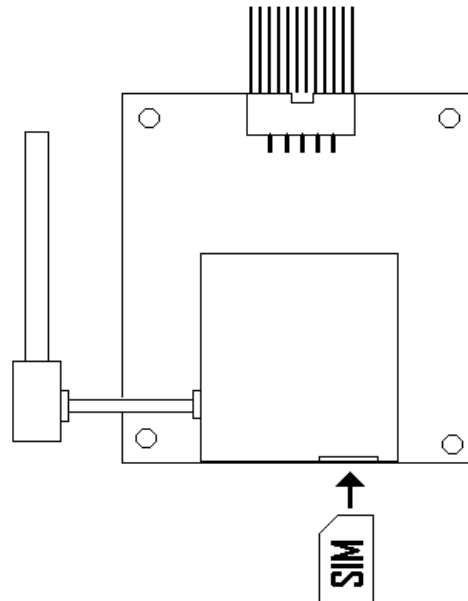

A green LED status has the following meanings:

- FLASHING FAST = searching for network
- SLOW FLASH = Registering on network
- ON CONTINUOUS = Data connection in progress

To attach the antenna with optional extension, remove the one from the series by pulling the plug directly from the connector module and inserting the new one.  
Insert the antenna into the proper hole (if using the antenna with the extension, use a press cable for the output of same).

## INSTALLATION OF MODEM

Remove the two central nuts that attach the board to the bottom (adjacent to the keys).

Fit the two hexagonal towers (A)

Place the modem board after removing the antenna.

Secure the board with the 2 nuts (B) previously removed.

Connect the flat to the board and the modem.

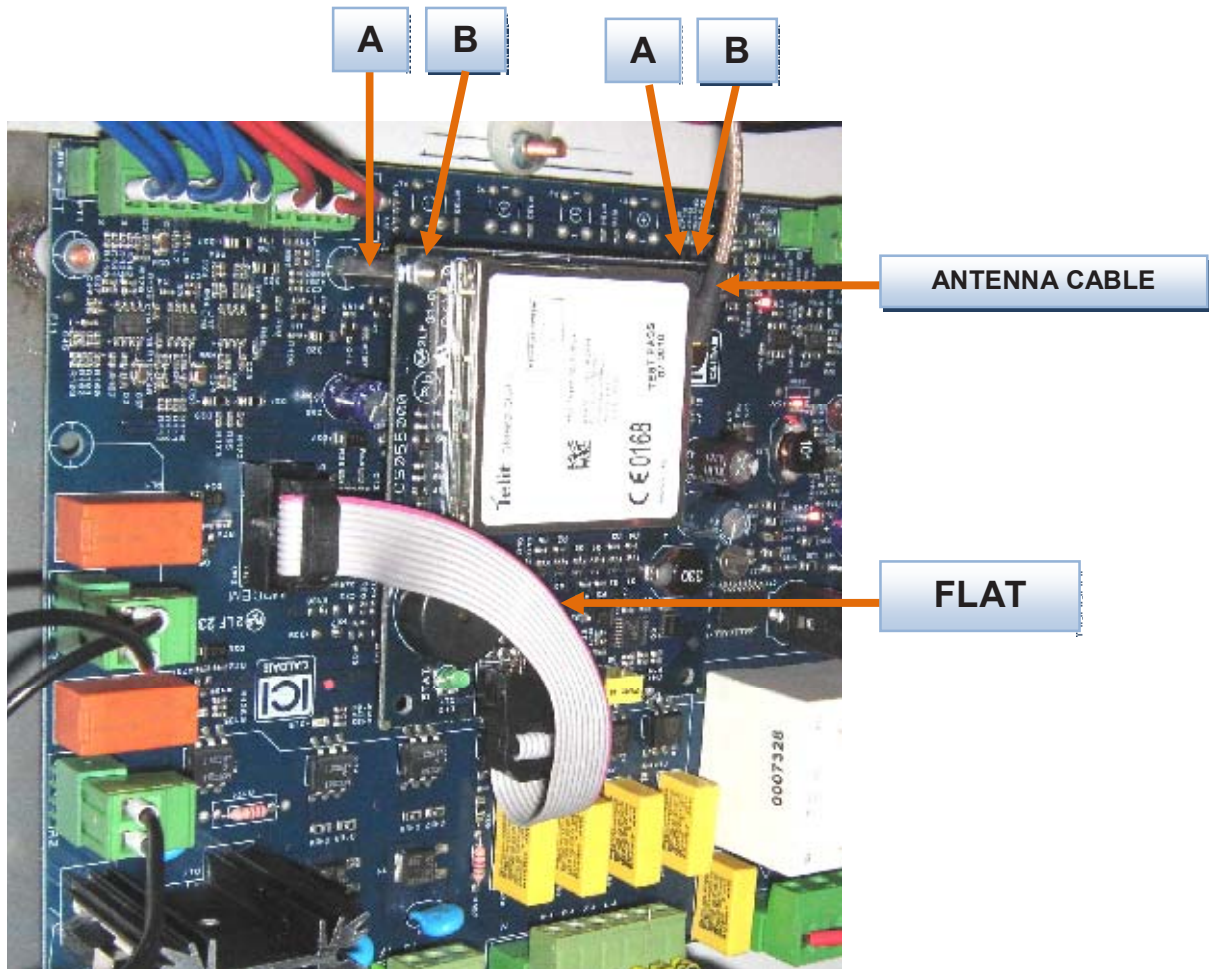

The standard antenna can be mounted inside the panel (with its double-sided adhesive) or put on the outside in a manner consistent with the length of the cable provided.

If necessary to improve reception, use the optional 10m antenna extension,

# 8 WIRING DIAGRAM

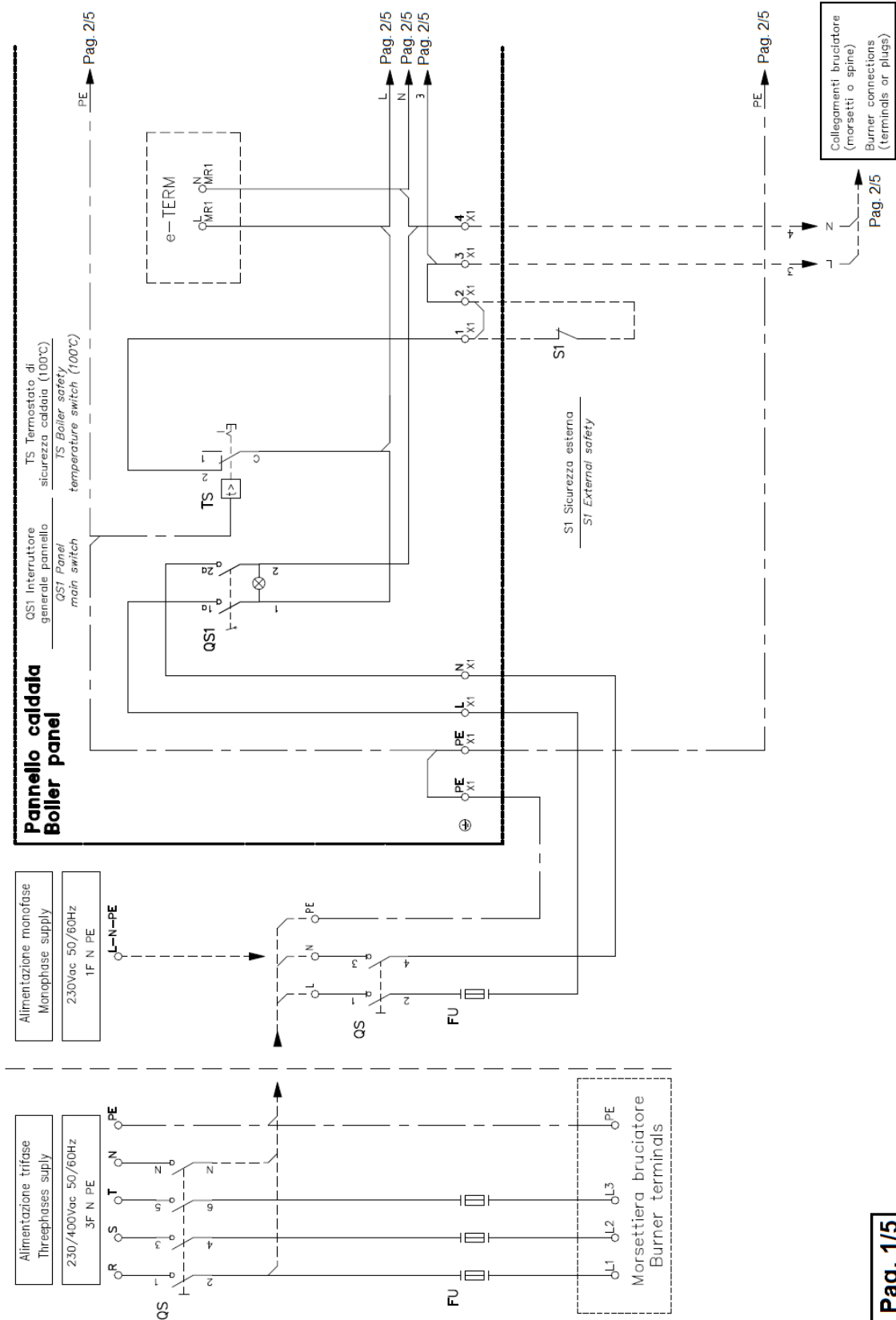

**Pannello caldaia  
Boiler panel**

Pag. 1/5

SA1 Selettore bruciatore  
AUT-0-MAN  
SA1 Burner selector  
AUT-0-MAN

TR1 Bitermostato caldaia  
TR1 Bithermostat

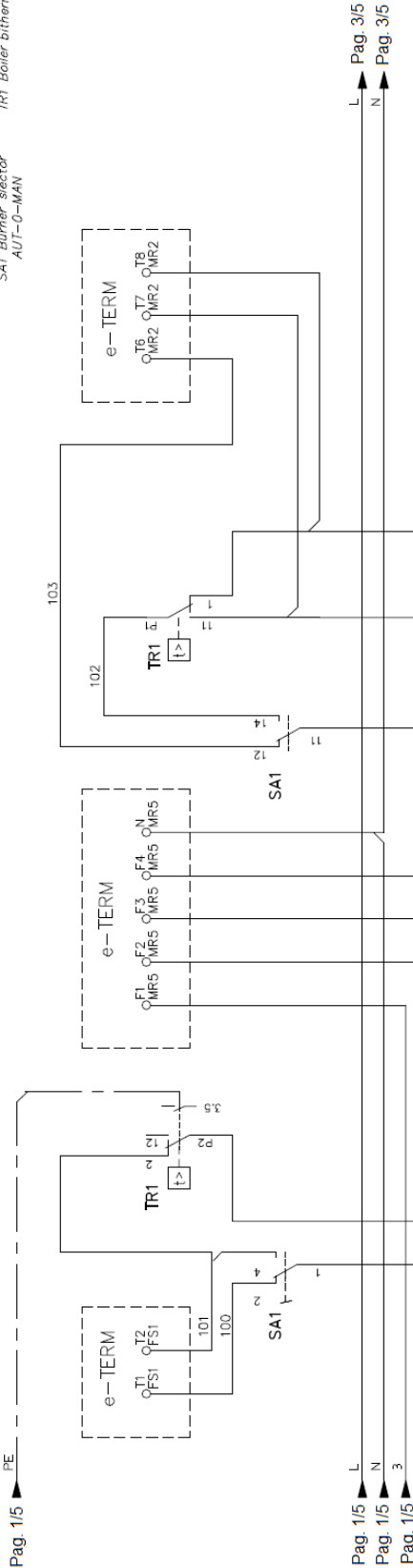

Pag. 1/5 L  
Pag. 1/5 N  
Pag. 1/5 3

Pag. 3/5 L  
Pag. 3/5 N

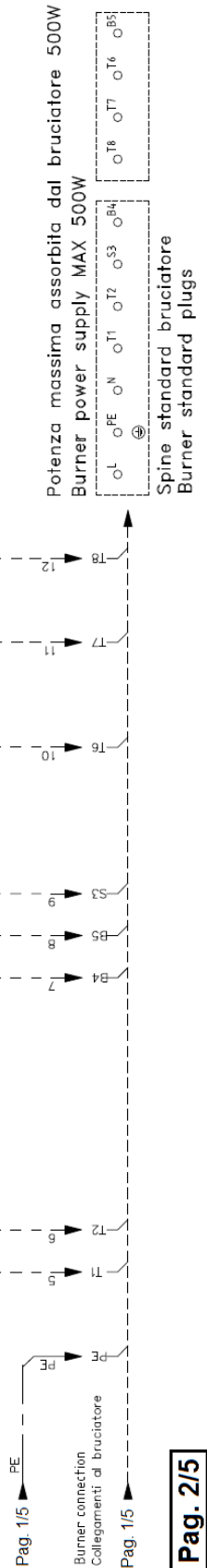

Potenza massima assorbita dal bruciatore 500W  
Burner power supply MAX 500W

Spine standard bruciatore  
Burner standard plugs

Pag. 1/5 PE  
Pag. 1/5 L  
Pag. 1/5 N  
Pag. 1/5 3

**Pag. 2/5**

SA2 Selettore uscita programmabile R1  
AUT - 0 - MAN

SA2 Programmable output R1 selector  
AUT - 0 - MAN

SA3 Selettore uscita programmabile R2  
AUT - 0 - MAN

SA3 Programmable output R2 selector  
AUT - 0 - MAN

## Pannello caldaia Boiler panel

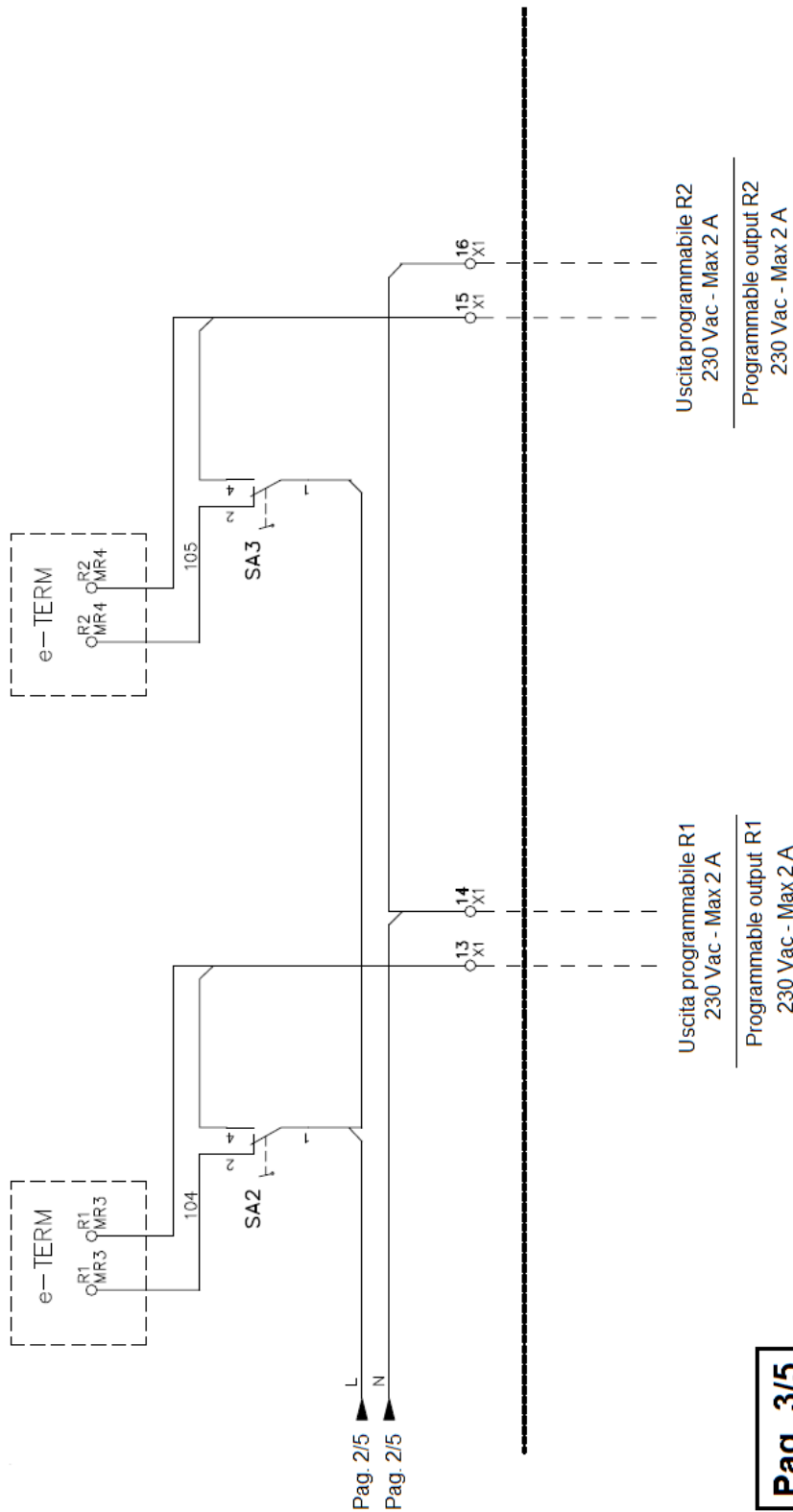



**Pannello caldaia  
Boiler panel**

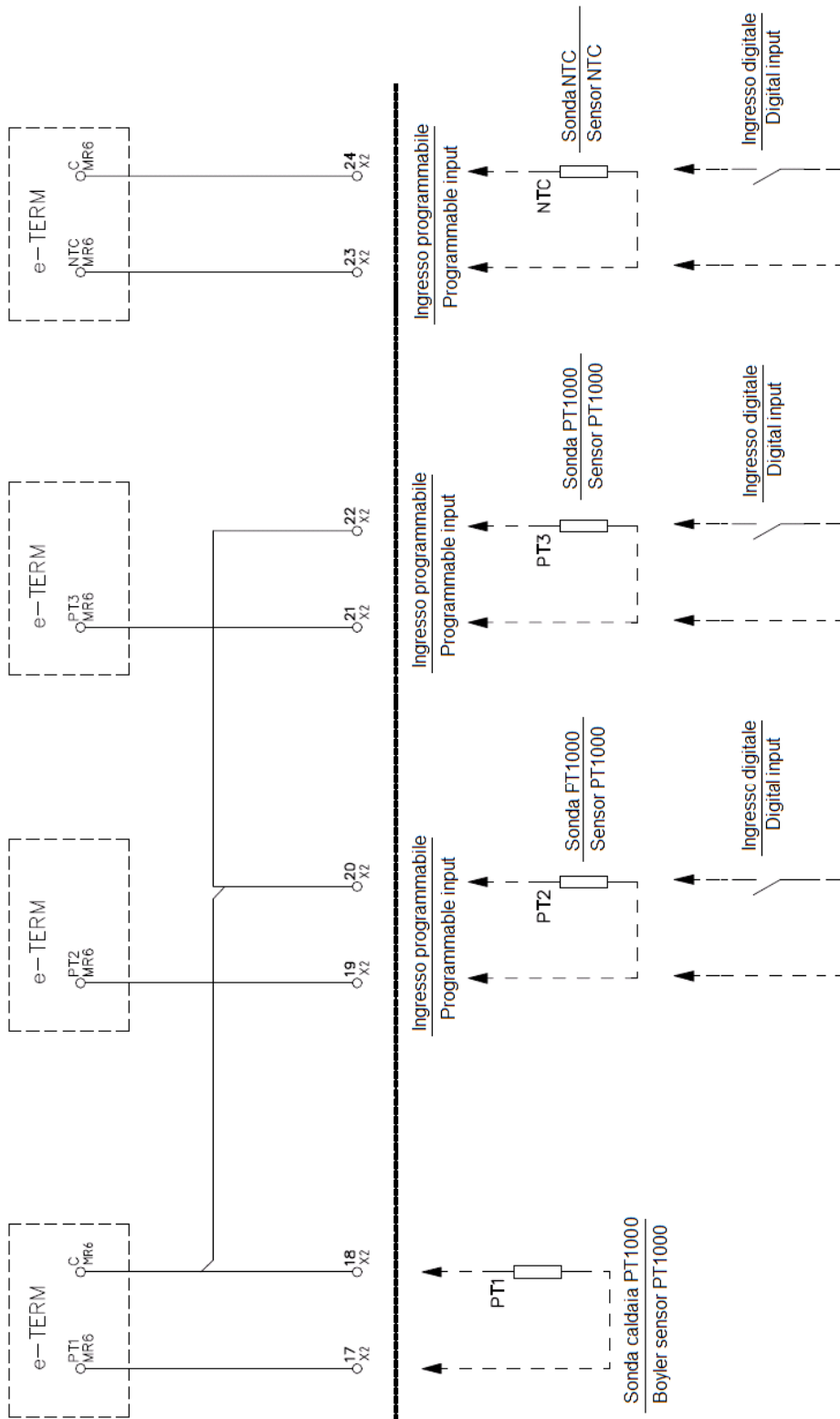

**Pannello caldaia  
Boiler panel**

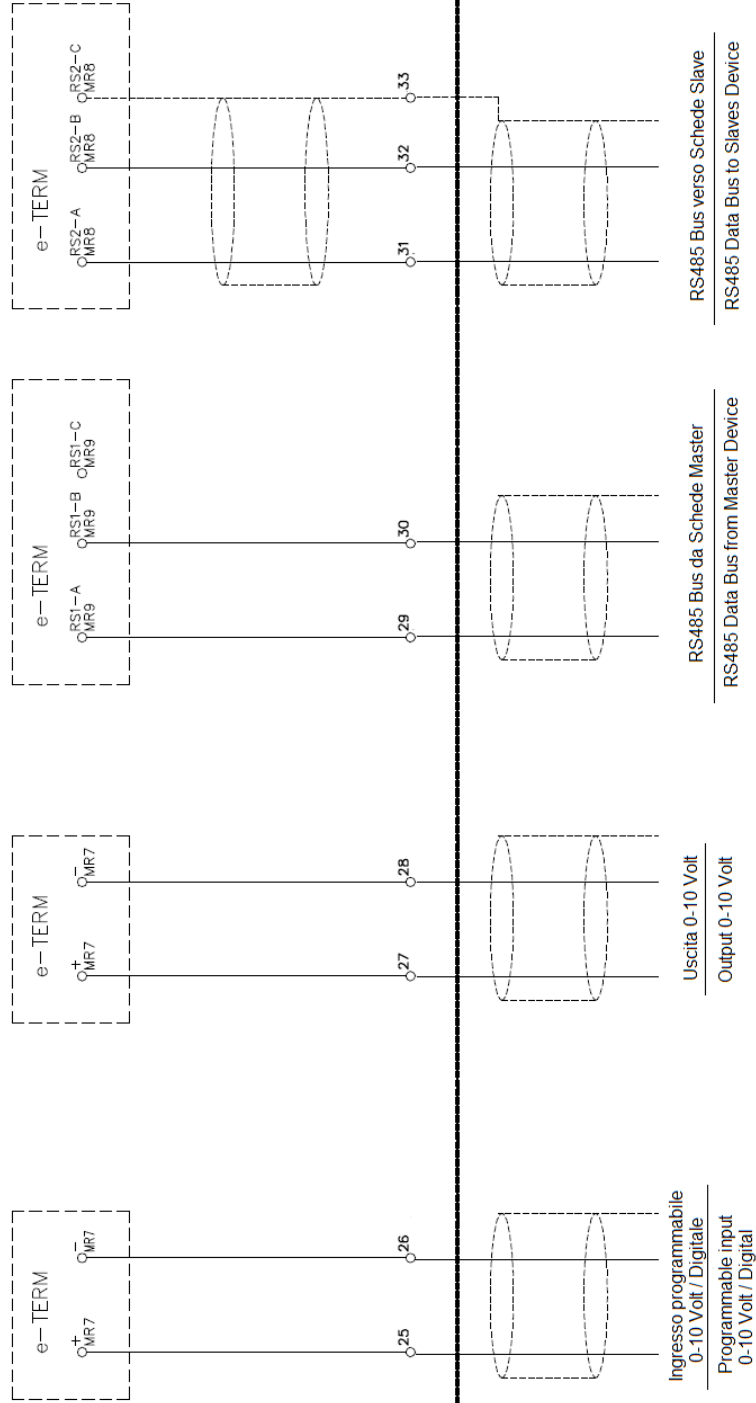

## 8 USING BURNER OR 0-10 VOLT MIXING VALVE

To control a burner or a 0-10 Volt mixing valve, use the specific output and properly configure the electronic control unit.

It is not possible to use the burner and a 0-10 Volt valve simultaneously.

If a 0-10 volt burner (such as premixed G150MXK or G250MX) is connected, disconnect the connector T6-T7-T8 directly on the electric board.

When the consent is given (closing T1-T2), with the switch in "AUTO" function, the burner automatically runs with the 0-10 V control when it detects voltage on the appropriate input (see burner diagram).

When the operation "MAN" is selected, the burner detects the closure of one of the two contacts (T6/T7 or T6/T8) and modulation automatically starts to the three points, ignoring the 0-10 V input.

In manual mode, the burner will then run in two-stages with the dual thermostat operation.

0-10 Volt operation modulation is automatically restored by placing the switch at "AUTO" on the condition that there is an interruption request (opening of T1 and T2) and at the beginning of the new request the function switch is in "AUTO"

For this reason you should leave the switch at the 0 position for some time before moving on to "AUTO" Otherwise the 0-10 volt operation will reset after the first OFF, up until the time when the burner will be driven at the power previously commanded by the dual thermostat in the input T6-T7-T8.

Burners other than those cited in the example may have a switching mode (0-10 Volts / 3 points) different from that described or may not have any switching (eg., burners made only for 0-10 volts).

Closely monitor the function mode of the burner installed.

## 9 USING THE MIXING VALVE WITH THREE POINTS 230 VAC

To control a 3-point mixing valve connect the burner in 0-10 Volt mode, as described in the previous section.

Use the connector T6-T7-T8 of the electric board after removing and isolating the three factory wired cables.

The junction of the valve actuator must be connected to T6, the contact down to T7 and T8 the contact up to T8.

After the connection, configure the line circuit board consistently (see the specific manual).

**It is not possible to use a mixing valve with three points if the burner requires a command from the contacts T6-T7-T8:**

**A mixer with three points can be used only in the case of single-stage burner or 0-10 Volt.**



---

Member of Finluc Group, registered in Bus. Reg. VR No. 02245640236  
Via G. Pascoli, 38 - 37059 Zevio - sect. Campagnola - VERONA - ITALY  
Tel 045/8738511 - Fax 045/8731148  
info@icicaldaie.com - [www.icicaldaie.com](http://www.icicaldaie.com)

---