

HRW 007 to 120



1.9 to 30.0 kW



2.6 to 38.1 kW



Technical Catalogue

TM HRW-A.4GB

Date : February 2007

Supersedes : TM HRW-A.3GB/12.05

Airwell

Description of Units

- ▶ **5 optimally compact case sizes, 13 models** with a nominal cooling capacity ratings ranging from **1.9 to 30.0 kW**.
- ▶ High efficiency horizontal units with **high COP** values.
- ▶ Easy access to the compressor, fan and electronic control box, through **wide removable panels**.
- ▶ **In-line** or **perpendicular** air blowing.
- ▶ Condensate drain pan with **anti-corrosion treatment** by oven-baked epoxy paint, equipped with a **float-type safety system** to protect against accidental condensate overflow.
- ▶ **3-speed direct drive fan** motor or **belt driven fan with variable pitch pulley**.
- ▶ **Heat exchanger with brazed stainless steel plates** on the water/refrigerant side, for improved efficiency.
- ▶ **Flow switch for antifreeze protection** (for models 019 to 120) as standard.
- ▶ **Bi-Flow thermostatic expansion valve** for a wide operating range.
- ▶ Stand-alone regulation by a **STORM electronic board which can be configured to 4 operating modes using the RCL user remote control**, which comprises a digital display and essential control keys.
- ▶ **The μ BMS mini-supervision station**, available as an optional extra, enables **32 units in 15 zones** to be monitored and managed, with **global or individual area programming**.



HRW 042, 048, 060 & 072

HRW 030 & 036

HRW 019 & 024

HRW 007, 009 & 012

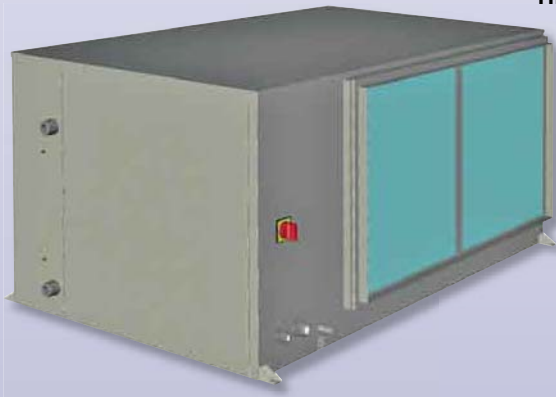

HRW 096 & 120

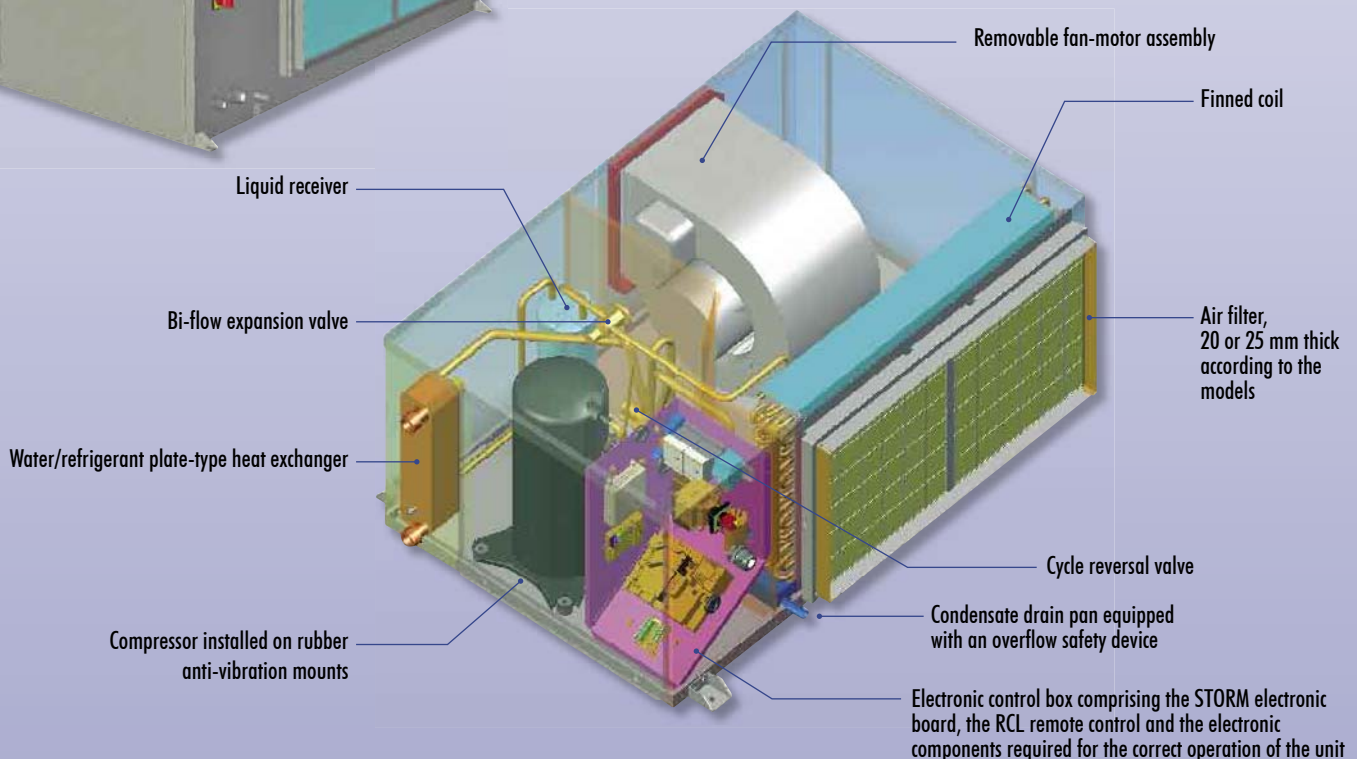

Technical Specifications

Introduction

The new generation of **HRW model reversible water source heat pumps** is the fruit of our considerable product experience and our awareness of the market, all combined with a technology based on the energy efficiency of machines, in order to provide a market offer for **units with the highest performance in terms of COP**.

Range

The **HRW horizontal units** are designed for installation in specifically designed false ceilings or in technical rooms, and are available with a range of nominal cooling capacity ratings of between **1.9 and 30.0 kW**, with **13 models** based on **5 different case sizes**.

Operating range

To enable a much wider operating range and operation using a water source in an application with a dry cooler, the standard HRW units are designed to operate in a **water source temperature range of between 13 and 45 °C**.

Casing design

The casing is made of galvanised sheet steel. To facilitate access to the main components, wide removable panels provide access to the compressor, the fan and the electronic control box.

The condensate drain pan has anti-corrosion treatment consisting of oven-baked epoxy paint.

The inside of the casing, on the fan compartment side, is coated with closed cell polyurethane foam thermal-acoustic insulation; this lagging is 15 mm thick and is classified M1. On the compressor compartment side, the thermal-acoustic insulation consists of Isofeutre felt, 15 mm thick (except on models 096 and 120).

Filtration

All units are factory equipped with a G2-M3 disposable air filter, 20 or 25 mm thick, according to the models. Optionally, the units can be fitted with G2-M1, G3-M3 or G3-M1 filter. The filter can be removed/installed from the side of the units without plenum and from the side or from the bottom of the units equipped with plenum, without having to remove the optional return duct.

Hydraulic connections

The water source outlet and return connectors are located on the outside of the unit, on the compressor compartment side. They are female gas type tapped fittings, $\varnothing 1/2"$, $3/4"$, or $1 1/4"$ (male), according to the models. The condensate evacuation connection is of the flexible type with an outside diameter of 16 mm for models 007 to 012, and of the smooth tube type, with an outside diameter of 19 mm for models 019 to 072, 22 mm for models 096 and 120.

Electronic control box

The electrical cabinet is located inside the compressor compartment.

A wide access panel is provided to facilitate the maintenance operations. Optionally, the models HRW 07 to 12 can be equipped with an electrical connection kit on front side and with a power on indicating light, avoiding thus acceding to the electrical box for electrical connections and inspection of power on presence.

The electrical power supply required for models HRW 007, 009, 012, 019 & 024 is 230 V / 1 Ph / 50 Hz, whereas models HRW 030 to 120 require 400 V / 3 Ph / 50 Hz + neutral. The compressors are factory equipped with an internal thermal protection with an automatic reset function.

Refrigerant circuit

The refrigerant circuit comprises a scroll or rotary type hermetic compressor, a cycle reversal valve, a water/refrigerant heat exchanger, a liquid receiver, a bi-flow thermostatic expansion valve and a finned coil.

Refrigerant circuit (continued)

The refrigerant circuit also comprises an HP pressure switch with manual reset (range 28-20 bar) and an LP pressure switch with an automatic reset function (range 1.4-2.4 bar). Two Shrader valves (HP & LP) are available for pressure measurement on the refrigerant circuit or on the front side of models 007 to 012.

The water/refrigerant heat exchanger is of the brazed stainless steel plate type, for increased efficiency. The anti-freeze safety of the heat exchanger is provided by a water pipe sensor located on the water outlet of the unit monitored by the electronic board. Maximum service pressure on the water side (27.5 bar) and on the refrigerant side (28 bar). The heat exchangers are particularly well adapted to the operation of reversible heat exchangers which have high thermal transfer rates for a low water flow-rate.

The air/refrigerant coil is made up of aluminium fins which are mechanically crimped onto copper tubes. The geometry of the coil and of the fin profile have been carefully designed to provide maximum efficiency in the operation of the units.

The cycle reversal valve is designed to be normally energised in heating mode. This logic enables the heat pump to continue to operate in cooling mode if this valve fails.

The liquid receiver enables the charge of HFC 407C refrigerant to be optimised, particularly in cooling mode, in order to maintain a high COP value.

A Bi-Flow expansion valve ensures and enables a wide operating range with water inlet temperatures which can vary between 13 °C and 45 °C at the minimum or maximum flow-rate.

Ventilation section

The fan compartment contains the fan-motor assembly, the air/refrigerant coil and the condensate drain pan. The ventilation section is completely isolated from fan compartment by a thermally and acoustically insulated partition wall.

Wide removable panels provide access to the various internal components. The condensate drain pan has an anti-corrosion treatment and comprises a float-type safety device to prevent accidental overflow of the pan.

All the units up to model 72 are equipped with a 3 speed direct-drive fan motor with isothermal protection against overheating during operation. The motor isothermal protection fault is displayed in the form of a coded signal on the LED of the RCL remote control.

The 3 fan speeds can be controlled either manually or automatically by the electronic management board of the unit. The fan-motor assembly is mounted on an independent chassis which is isolated from the casing by anti-vibration mounts.

Belt type drive with variable pitch pulley is supplied on models 096 and 120.

In the standard configuration, the fan blows **straight in line with the air intake**. The **perpendicular blowing** option is available on all units by switching the side panels and the fan-motor assembly.

Suspension kit

In order to facilitate installation on site, a suspension kit consisting of rubber blocks and washers is supplied with the units (except for models 096 and 120).

Optional features (factory installed)

- Wired main disconnect switch to be installed on the casing (for models 019 to 120 only),
- Electric heater at discharge side,
- General alarms fault report,
- Electrical connection kit (for models 007 to 012 only),
- Compressor jacket (for models 007 to 012 only),
- Motorized water valve (for models 019 to 120 only),
- Return plenum (for models 007 to 012 only).

Control Features

STORM electronic board

All HRW water source heat pumps are, in their standard version, equipped with a **STORM** electronic board which manages their operation and their safety devices.

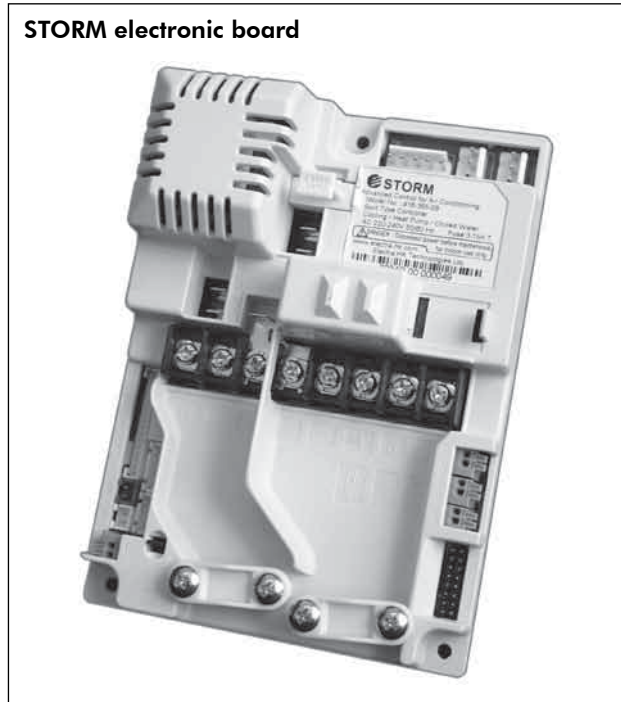

The configuration of the **STORM** electronic board enables four different operating modes for water source heat pumps by selecting the following systems :

- Thermodynamic cooling and heating operation (**RC**);
- Thermodynamic cooling and heating operation or heating operation with an additional electric heater (**SH**);
- Thermodynamic cooling operation and electrical heating operation (**RH**);
- Thermodynamic cooling operation only (**ST**).

RCL user remote control

An **RCL user remote control** is supplied in the standard version, in the electrical control box of the units.

It enables individually controlled operation or stand-alone regulation.

The RCL remote control is ergonomically designed and discreet. It comprises a digital display and essential functions such as :

- On/Off,
- Selection of operating mode,
- Room temperature display,
- Fan speed selection,
- Temperature set-point adjustment.

A keypad locking function is also available.

The RCL user remote control comprises a **Display LED** which shows the operating status of the water source heat pump (Lit : On - Unlit : Off), and it also enables an operational fault to be identified by flashing a specific code.

RCL user remote control



Master/slaves control : the standard version of the **STORM** electronic board enables operation in master/slaves regulation mode for **up to 10 water source heat pumps using a single RCL user remote control**.

This configuration enables the installer to save on the purchase and wiring of equipment such as auxiliary relays and multi-wire cables between the various water source heat pumps. Only a bus cable with 2 twisted pairs is necessary between the master and slave units.

When a request for operation in cooling mode is received, the fan-motor assembly is started up immediately and the compressor does not start until after an effective time delay of 180 seconds. The RCL remote control enables operation in cooling-only mode or in automatic cooling/heating mode with, at a given temperature set-point used as a switch-over point, a neutral switch-over range of ± 3 °C from cooling to heating mode. In cooling mode, the fan runs permanently and the 3 speed ventilation can be implemented in automatic or manual mode: HS, MS, or LS (when applied).

When a request for operation in heating mode is received, the fan-motor startup is controlled by the electronic board and the temperature of the ICT sensor; the reversal valve is activated before the compressor and the latter does not start until after an effective time delay of 180 seconds. The RCL remote control enables operation in heating-only mode or in automatic heating/cooling mode with, at a given temperature set-point used as a switch-over point, a neutral switch-over range of ± 3 °C from heating to cooling mode. In heating mode, the fan can operate either cyclically (the fan stops when the set temperature is reached) or permanently and the 3 speed ventilation can be implemented in automatic or manual mode: HS, MS, or LS (when applied).

Measurement of the room air temperature : the **STORM** card electronic regulation enables the selection of a room temperature measurement mode which uses an ambient temperature sensor (RCT) in the RCL remote control, or a return temperature sensor (RAT) located directly on the water source heat pump.

Anti-short cycle : after each compressor shut-down, a time delay of 180 seconds is introduced by the electronic board. This time delay constitutes an anti-short cycle device and therefore helps to protect the compressor.

Control Features (continued)

Variable sequential start-up function : when the system is first energised, or after a power cut, or after opening and closing the "CLK" contact, a random time delay of 0 to 30 seconds is introduced by the electronic board to prevent the water source heat pumps from all starting up simultaneously, thus avoiding a power surge.

Emergency shut-down / stand-by / night setback : the electronic board has two "CLK" terminals which shut the unit down immediately.

By incorporating an area thermostat in series, the "CLK" contact can **also be used as a night setback** and the water source heat pump will start up again as soon as the ambient temperature drops below the set point of the setback thermostat.

Anti-freeze safety function : this is provided by two temperature sensors. In cooling mode an "ICT" temperature sensor located in the finned coil protects the water source heat pump against accidental freezing.

In heating mode, the safety function is provided by an "LWT" minimum water outlet temperature sensor. The anti-freeze fault read by the temperature sensor is displayed by a coded signal on the LED of the RCL remote control.

The automatic reset LP pressure switch completes the anti-freeze safety function by monitoring a minimum acceptable suction pressure to ensure correct operation of the compressor. This LP fault is also displayed by a coded signal on the LED of the RCL remote control.

High temperature safety function : the "ICT & LWT" temperature sensors check that the condensation temperature at the finned coil and the water temperature at the outlet of the water/refrigerant heat exchanger do not exceed the authorised limits.

The manual reset HP pressure switch completes the high temperature safety function. The high temperature safety fault read by the ICT and LWT sensors and the HP pressure switch cut-off is displayed by a coded signal on the LED of the RCL remote control.

Condensate drain pan fluid level safety function : the **STORM** electronic board permanently monitors the water level in the condensate drain pan, by means of a float type contact switch.

If the water reaches an abnormally high level, the machine is switched to safety mode and the fault is displayed by a coded signal on the LED of the RCL remote control.

Fault reports : the electronic regulation carried out by the **STORM** board uses coded signals to remotely report eight different possible machine faults on the display LED of the RCL remote control :

- HP pressure switch tripped,
- LP pressure switch tripped,
- fan motor isothermal fault,
- heating mode anti-freeze fault,
- minimum water temperature limit in heating or cooling mode,
- maximum water temperature limit in heating or cooling mode,
- cooling mode anti-freeze fault,
- condensate drain pan high level safety fault.

The **STORM** electronic board also enables the general machine fault to be sent to a remote fault relay via a dry contact (optional).

Phase monitor : The water source heat pumps (three-phased models) are factory equipped with a phase monitor to detect the presence and order of the phases.

Motorized valve : The **STORM** electronic board has a 230 volt output for an (optional) motorized valve controlled by the operation of the compressor, in order to enable the flow-rate of the hydraulic pump(s) to be regulated according to the manometric pressure in the water source.

System without water source heater : The **STORM** electronic board can be configured to stop the water source heat pump if the water temperature in the system becomes too low, and to automatically start an electric air flow heater which is monitored by the room temperature regulation sensor (RCL) or the air intake temperature sensor (RAT).

Electric heater : HRW water source heat pumps can be factory equipped with an optional in-duct air heater located at the fan outlet.

The electric heater function can, depending on the configuration of the **STORM** electronic board, be used in place of the thermodynamic heating as soon as the temperature in the water system drops below a minimum limit (SH system), or it can be used as an electric heating system on its own (RH system).

The HRW 07, 09, 12, 19 and 24 units, which operate on a single-phase 230 volt mains supply, are factory equipped with **two electric heater stages**. The other models, which operate on a three-phase 400 volt mains supply, have a single-stage electric heater.

μBMS mini-supervision station

This centralised control unit is proposed **as an option**, and can be installed in place of the local RCL remote control or connected to the **STORM** electronic board as a supervision station to monitor and manage **32 water source heat pumps in 15 zones** from a single point, in addition to the local RCL remote controls.

The μ BMS mini-supervision station enables the zones to be programmed with global control for all zones, or with individual control of each zone with programming of the operating time ranges over a 7 day period, with management of the heating, cooling and night setback modes.

It also provides the possibility of having different set-points in different zones.

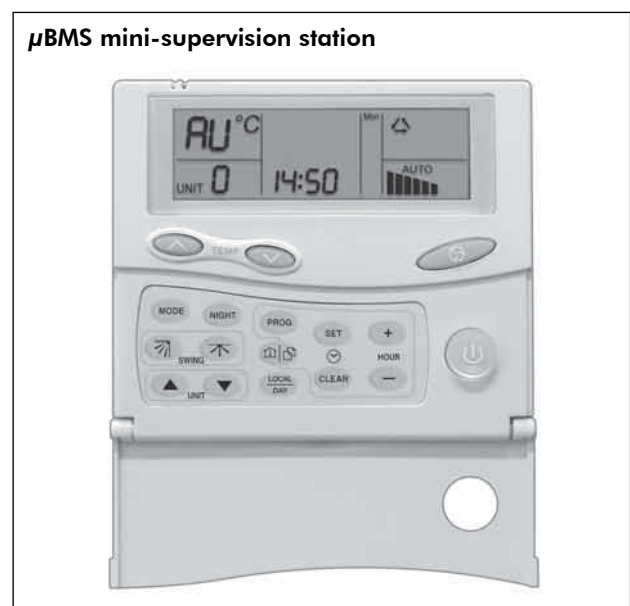

Refrigerant Flow Diagram

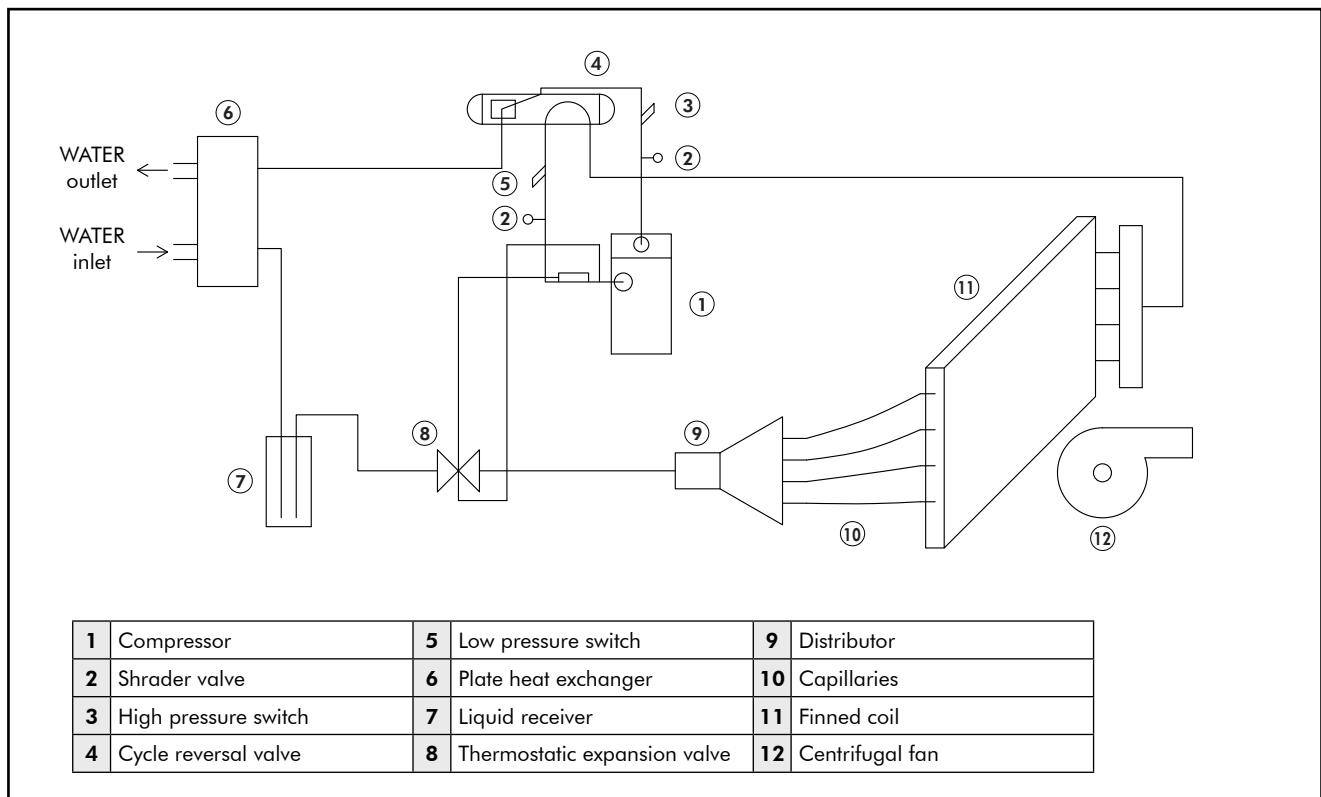

Operating Limits

Air temperature limits		Standard unit	
		Cooling	Heating
Minimum ambient air temperature	°C	10	10
Normal ambient air temperature	°C	27	20
Maximum ambient air temperature	°C	38	30
Minimum entering air temperature (1) (2)	°C	10	10
Normal entering air temperature dry bulb/wet bulb	°C	27/19	20
Maximum entering air temperature dry bulb/wet bulb (1) (2)	°C	38/28	27

Water temperature limits		Standard unit	
		Cooling	Heating
Minimum entering water temperature (1) (2)	°C	15 *	13
Normal entering water temperature	°C	30	20
Maximum entering water temperature (1) (2)	°C	50 *	32

(1) At nominal air and water flow rate conditions according to ISO 14511-2 standard.

(2) Minimum and maximum values can not be combined. If one of the values is at maximum or at minimum, the two other conditions must not exceed the normal conditions for standard units.

* For conditions exceeding these temperatures, please consult factory.

Initial start-up and winter operation of the units are guaranteed at ambient air temperature of 5 °C, with entering air of 5 °C and entering water of 13 °C, with nominal air and water flow rates used in performance test according to ISO 14511-2 standard.

Note : These operating conditions are not normal or continuous ones. It is assumed that such a start-up is for the purpose of bringing the building space up to occupancy temperature.

Physical Data

MODELS		HRW 007	HRW 009	HRW 012	HRW 019	HRW 024
CAPACITIES						
Total cooling capacities (1)	W	1941	2338	2974	5278	5923
Sensible cooling capacities (1)	W	1441	1770	2253	3978	4502
Heating capacities (2)	W	2656	2784	3768	5826	7370
VENTILATION						
Nominal air flow (3)	m ³ /h	440	520	650	1181	1312
Nominal static pressure (3)	Pa	50	50	50	50	60
Motor power	W	190	190	190	145	145
Fan speeds	Nbr	3	3	3	3	3
Air filters - Number / Efficiency		1 / G2	1 / G2	1 / G2	2 / G2	2 / G2
Air filters - Dimensions / Thickness	mm	600x200/20	600x200/20	600x200/20	365x300/25	365x300/25
HYDRAULIC CIRCUIT						
Plate heat exchanger	Nbr	1	1	1	1	1
Nominal water flow (1)	l/s	0.116	0.142	0.194	0.279	0.350
WPD at nominal water flow (1)	kPa	1	2	3	16	18
Hydraulic connections - Inlet / Outlet	Inches	ISO G 1/2" INT			ISO G 3/4" INT	
Condensate outlet - External Ø	mm	16	16	16	19	19
REFRIGERANT CIRCUIT						
Number of circuit		1	1	1	1	1
HFC 407C refrigerant charge	g	633	660	694	1160	1586
Compressor	Type	Rotary				
DIMENSIONAL DATA						
Length	mm	900	900	900	900	900
Width	mm	530	530	530	600	600
Height	mm	239	239	239	439	439
Weight - Operating	kg	55	55	55	80	85
Weight - Shipping	kg	59	59	59	87	92
ELECTRICAL DATA						
Power input - Cooling mode (4)	W	650	720	960	1557	2029
Power input - Heating mode (4)	W	690	728	1010	1611	2206
Electrical heating coil - Number / Capacity (5)	W	1 / 1200	1 / 1600	1 / 2000	2/1500+750	2/1500+1500
Power input of electric heating coil (5)	W	1200	1600	2000	2250	3000
Electrical power supply		230V/1Ph/50Hz ± 10%				
Fan max. current, E.S.P = 0 Pa	A	0.46	0.57	0.83	1.45	1.5
Compressor nominal current (6)	A	2.8	3.0	4.0	7.0	10.0
Compressor starting current (7)	A	16	16	18.9	32.9	45.0

(1) Nominal cooling capacities based on : entering air temperature of 27 °C dry bulb, 19 °C wet bulb with entering water temperature of 30 °C.

(2) Nominal heating capacities based on : entering air temperature of 20 °C dry bulb, 15 °C wet bulb with entering water temperature of 20 °C.

(3) Airflow and static pressure at nominal point are given for high speed. See table next page for other speeds.

(4) Absorbed power (compressor + fan) at nominal conditions.

(5) Electric heating coil is an optional feature available for SH & RH versions.

(6) Nominal currents are given at +/- 5%.

(7) Starting currents are given at +/- 10%.

Physical Data (continued)

MODELS		HRW 030	HRW 036	HRW 042	HRW 048	HRW 060
CAPACITIES						
Total cooling capacities (1)	W	8691	10138	11366	12965	14344
Sensible cooling capacities (1)	W	6315	7278	8849	10051	10988
Heating capacities (2)	W	9759	11036	14422	14904	16147
VENTILATION						
Nominal air flow (3)	m ³ /h	1490	1580	2040	2750	2840
Nominal static pressure (3)	Pa	100	100	100	100	100
Motor power	W	210	245	320	550	550
Fan speeds	Nbr	3	3	3	3	3
Air filters - Number / Efficiency		2 / G2	2 / G2	2 / G2	2 / G2	2 / G2
Air filters - Dimensions / Thickness	mm	385x350/25	385x350/26	450x440/25	450x440/25	450x440/25
HYDRAULIC CIRCUIT						
Plate heat exchanger	Nbr	1	1	1	1	1
Nominal water flow (1)	l/s	0.490	0.564	0.720	0.784	0.930
WPD at nominal water flow (1)	kPa	23	25	33	34	40
Hydraulic connections - Inlet / Outlet	Inches	ISO G 3/4" INT				
Condensate outlet - External Ø	mm	19	19	19	19	19
REFRIGERANT CIRCUIT						
Number of circuit		1	1	1	1	1
HFC 407C refrigerant charge	g	1594	1950	2100	2150	2200
Compressor	Type	Scroll				
DIMENSIONAL DATA						
Length	mm	1050	1050	1250	1250	1250
Width	mm	660	660	705	705	705
Height	mm	460	460	513	513	513
Weight - Operating	kg	100	112	133	140	144
Weight - Shipping	kg	109	121	143	150	154
ELECTRICAL DATA						
Power input - Cooling mode (4)	W	2658	3044	3584	4200	4989
Power input - Heating mode (4)	W	2983	3460	3920	4300	5150
Electrical heating coil - Number / Capacity (5)	W	1 / 3750	1 / 4500	1 / 5500	1 / 6500	1 / 7500
Power input of electric heating coil (5)	W	3750	4500	5500	6500	7500
Electrical power supply		400V/3Ph/50Hz ± 10%				
Fan max. current, E.S.P = 0 Pa	A	2.6	2.4	3.55	4.7	4.7
Compressor nominal current (6)	A	4.5	5.4	5.7	7.0	7.5
Compressor starting current (7)	A	40.0	46.0	51.5	54.0	65.5

- (1)** Nominal cooling capacities based on : entering air temperature of 27 °C dry bulb, 19 °C wet bulb with entering water temperature of 30 °C.
(2) Nominal heating capacities based on : entering air temperature of 20 °C dry bulb, 15 °C wet bulb with entering water temperature of 20 °C.
(3) Airflow and static pressure at nominal point are given for high speed. See table next page for other speeds.
(4) Absorbed power (compressor + fan) at nominal conditions.
(5) Electric heating coil is an optional feature available for SH & RH versions.
(6) Nominal currents are given at +/- 5%.
(7) Starting currents are given at +/- 10%.

Physical Data (continued)

MODELS		HRW 072	HRW 096	HRW 120
CAPACITIES				
Total nominal total cooling capacity (1)	W	17174	21743	29951
Sensible nominal cooling capacity (1)	W	13536	17986	24413
Compressor power input @ nominal cooling conditions	W	4970	5380	7163
EER		3.46	4.04	4.18
Nominal heating capacity (2)	W	21500	26637	38109
Compressor power input @ nominal heating conditions	W	6046	7007	8894
COP		3.56	3.80	4.28
FAN AND MOTOR				
Nominal airflow (3)	m ³ /h	3570	4700	5600
Nominal static pressure (3)	Pa	125	125	225
Fan type	-	Centrifugal		
Number of fans	-	1	1	1
Drive type	-	Direct	Belt with variable pitch pulley	
Power supply	(V/Ph/Hz)	230/1/50	400/3/50	400/3/50
Motor power	W	550	1100	1500
Maximum fan current ESP=0Pa	A	6.9	2.5	4.1
Speeds	Nbr	3	-	-
Air filter - Qty / Efficiency	-	2 / G2	2 / G2	2 / G2
Air filter - Dimensions	mm	450x440x25	620x650x25	620x650x25
HYDRAULIC CIRCUIT				
Plate heat exchanger	Nbr	1	1	1
Hydraulic E/L connections	Type	ISO G 3/4" INT	ISO G 1"1/4	ISO G 1"1/4
Max. water pressure	Bar	31	31	31
Nominal water flow (1)	l/s	1.09	1.35	1.78
Nominal water pressure drop (1)	kPa	61	55	114
Drain pan connection Ø ext.	inches	3/4"	7/8"	7/8"
REFRIGERANT CIRCUIT				
Number of circuit	-	1	1	1
R407C Charge	g	3200	5100	5100
Compressor	type	Scroll		
DIMENSIONS				
Length	mm	1250	1680	1680
Width	mm	705	955	955
Height	mm	513	770	770
Weight	kg	149	253	262
Packed weight	kg	159	275	284
ELECTRICAL DATA				
Cooling mode power consumption (4)	W	6280	6317	8547
Heating mode power consumption (4)	W	7347	7895	10224
Power supply	V/Ph/Hz	400V/3Ph/50Hz + neutral		
Electrical heater - Number / Capacity (5)	W	1 / 9000	1 / 13000	1 / 16000
Compressor starting current (6)	A	101	111	118

(1) Nominal cooling capacities based on : entering air temperature of 27 °C dry bulb, 19 °C wet bulb with entering water temperature of 30 °C.

(2) Nominal heating capacities based on : entering air temperature of 20 °C dry bulb, 15 °C wet bulb with entering water temperature of 20 °C.

(3) Airflow and static pressure at nominal point are given for high speed. See table next page for other speeds.

(4) Power consumption at nominal conditions including fan.

(5) Electric heater is an optional feature available for SH & RH versions.

(6) Starting currents are given at +/- 10%.

Note : All ratings (cooling and heating capacities and power consumptions) are given according to International Standard ISO 13256-1.

Fan Performance Data

Models	Speeds	External static pressure (Pa)												
		0	25	50	75	100	125	150	175	200	225	250	275	300
HRW 007	HS	520	475	440	400	360								
	MS	440	400	360	340	280								
	LS	380	330	280	230									
HRW 009	HS	570	550	520	490	455								
	MS	500	475	450	420	375								
	LS	440	415	370	330	270								
HRW 012	HS	700	670	650	620	580								
	MS	540	525	505	485	460								
	LS	480	460	430	400	370								
HRW 019	HS	1490	1420	1345	1270	1195	1115							
	MS	1270	1220	1170	1115	1050	975							
	LS	1055	1015	970	925	880	840							
HRW 024	HS	1645	1540	1440	1345	1250	1160							
	MS	1475	1370	1280	1190	1110	1040							
	LS	1250	1160	1085	1020	960	905							
HRW 030	HS	1700	1670	1640	1605	1570	1535	1495	1450	1405				
	MS	1400	1380	1350	1330	1300	1270	1240	1205	1170				
	LS	1105	1090	1070	1055	1035	1015	990	965	930				
HRW 036	HS	2050	2000	1950	1890	1830	1765	1700	1625	1545				
	MS	1760	1720	1670	1625	1575	1520	1460	1400	1325				
	LS	1500	1460	1420	1380	1330	1285	1230	1175	1110				
HRW 042	HS	2280	2235	2185	2135	2080	2025	1960	1895	1800				
	MS	1920	1900	1875	1850	1820	1790	1755	1715	1670				
	LS	1530	1525	1515	1505	1500	1495	1485	1475	1460				
HRW 048- 060	HS	3370	3300	3225	3150	3060	2980	2890	2800	2700				
	MS	2885	2820	2745	2675	2600	2520	2440	2350	2260				
	LS	2450	2385	2320	2250	2180	2100	2025	1940	1850				
HRW 072	HS	3802	3770	3720	3675	3630	3580	3530	3480	3430	3375	3320		
	MS	2930	2900	2865	2825	2790	2760	2720	2685	2650	2620	2580		
	LS	2320	2280	2250	2220	2180	2150	2115	2080	2045	2010	1980		
HRW 096	0 turn	6000	5778	5544	5300	5010	4678	4250	3578					
	1 turn	5645	5428	5178	4910	4578	4156	3400						
	2 turns	5360	5122	4850	4533	4144	3555							
	3 turns	5025	4778	4483	4133	3639								
HRW 120	0 turn	8700	8440	8120	7800	7480	7150	6800	6410	6000	5600	5100	4580	4000
	1 turn	8400	8085	7740	7400	7020	6640	6230	5800	5340	4840	4310	3680	2950
	2 turns	7960	7650	7310	6960	6580	6160	5730	5240	4670	4010	3120		
	3 1/2 turns	7420	7070	6700	6300	5870	5410	4910	4340	3650	2800			

Airflows are given for supply voltage of 230 V for models up to 072 and 400 V/3 Ph/50 Hz for models 096 and 120, dry coil and G2 clean filter.

Airflow Correction Factors

	Percent of nominal airflow						
	85	90	95	100	105	110	115
Total cooling capacity	0.972	0.982	0.993	1.00	1.007	1.010	1.013
Sensible cooling capacity	0.926	0.948	0.974	1.00	1.027	1.055	1.066
Power input - Cooling	0.977	0.984	0.993	1.00	1.011	1.018	1.028
Total heat rejection	0.975	0.983	0.991	1.00	1.008	1.015	1.018
Heating capacity	0.967	0.978	0.990	1.00	1.009	1.017	1.024
Power input - Heating	1.009	1.006	1.003	1.00	0.997	0.995	0.993
Total heat absorption	0.967	0.976	0.989	1.00	1.010	1.019	1.025

Acoustical Data

Models		HRW 007		HRW 009		HRW 012	
Speeds	Type	Global sound pressure level dB(A)	Global sound power level dB(A)	Global sound pressure level dB(A)	Global sound power level dB(A)	Global sound pressure level dB(A)	Global sound power level dB(A)
HS	CONFIGURATION A	52.5	56.2	55.5	59.2	60	63.7
	CONFIGURATION B	43	46.7	45.5	49.2	50	53.7
	CONFIGURATION C	41	44.7	43.5	47.2	46.5	50.2
	CONFIGURATION D	39.5	43.2	41	44.7	44	47.7
MS	CONFIGURATION A	49.5	53.2	52.5	56.2	55.5	59.2
	CONFIGURATION B	41.5	45.2	43	46.7	45.5	49.2
	CONFIGURATION C	39.5	43.2	41	44.7	43.5	47.2
	CONFIGURATION D	38.3	42	39.5	43.2	41	44.7
LS	CONFIGURATION A	45.5	49.2	49.5	53.2	52.5	56.2
	CONFIGURATION B	39.5	43.2	41.5	45.2	43	46.7
	CONFIGURATION C	38.5	42.2	39.5	43.2	41	44.7
	CONFIGURATION D	37.5	41.2	38.3	42	39.5	43.2

Configuration A

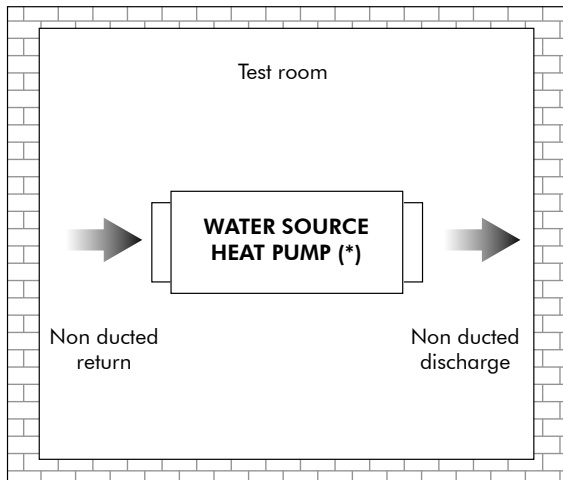

(*) Unit suspended at 1 metre from ground.

Configuration C

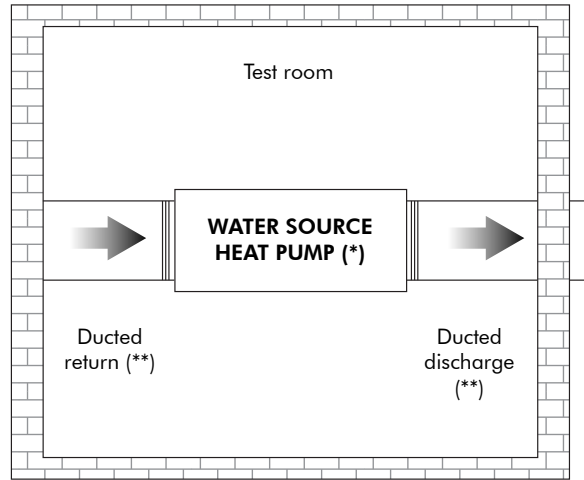

(*) Unit suspended at 1 metre from ground.
 (**) 2 metre long acoustic duct.

Configuration B

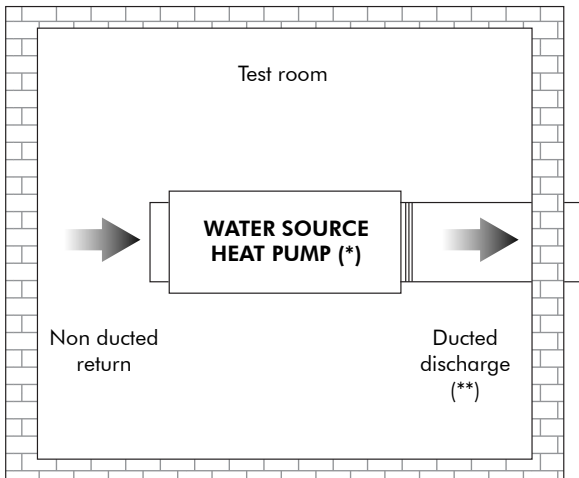

(*) Unit suspended at 1 metre from ground.
 (**) 2 metre long acoustic duct.

Configuration D - Unit with return air plenum

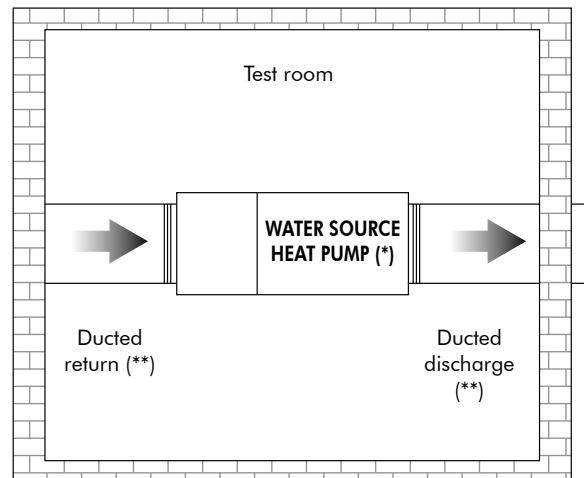

(*) Unit suspended at 1 metre from ground.
 (**) 2 metre long acoustic duct.

Acoustical Data (continued)

Sound Power Levels Lw - HRW 019

Speeds	Type	Frequency						Global dB(A)
		125 Hz	250 Hz	500 Hz	1k Hz	2k Hz	4k Hz	
HS	Lw radiated inlet + casing (Config. A)	53.9	57.1	57.8	60.6	54.0	46.2	64.5
	Lw radiated casing only (Config. B)	50.0	50.2	50.1	52.5	49.5	40.9	57.7
MS	Lw radiated inlet + casing (Config. A)	51.4	53.8	55.0	57.7	52.7	43.3	61.7
	Lw radiated casing only (Config. B)	47.1	46.6	47.4	49.1	45.5	35.5	54.4
LS	Lw radiated inlet + casing (Config. A)	48.9	50.4	52.2	54.9	51.3	40.4	59.1
	Lw radiated casing only (Config. B)	44.2	43.1	44.7	45.7	41.5	30.1	51.1

Sound Power Levels Lw - HRW 024

Speeds	Type	Frequency						Global dB(A)
		125 Hz	250 Hz	500 Hz	1k Hz	2k Hz	4k Hz	
HS	Lw radiated inlet + casing (Config. A)	56.9	58.8	58.7	62.3	59.9	50.2	66.8
	Lw radiated casing only (Config. B)	50.5	51.1	51.6	52.3	50.3	42.6	58.3
MS	Lw radiated inlet + casing (Config. A)	54.4	55.6	56.7	60.0	56.4	45.5	64.1
	Lw radiated casing only (Config. B)	49.6	48.6	49.0	50.3	47.5	38.6	56.2
LS	Lw radiated inlet + casing (Config. A)	52.7	52.6	54.3	57.0	52.9	40.7	61.3
	Lw radiated casing only (Config. B)	49.0	45.5	47.5	47.5	43.9	34.2	54.1

Sound Power Levels Lw - HRW 030

Speeds	Type	Frequency						Global dB(A)
		125 Hz	250 Hz	500 Hz	1k Hz	2k Hz	4k Hz	
HS	Lw radiated inlet + casing (Config. A)	50.5	54.3	58.1	59.0	54.0	48.1	63.3
	Lw radiated casing only (Config. B)	48.4	48.4	51.5	51.3	46.4	38.7	56.7
MS	Lw radiated inlet + casing (Config. A)	48.2	51.7	55.2	56.2	50.2	43.2	60.3
	Lw radiated casing only (Config. B)	46.3	44.7	48.3	49.9	43.0	32.7	54.2
LS	Lw radiated inlet + casing (Config. A)	45.6	51.1	52.3	53.9	47.0	43.2	58.2
	Lw radiated casing only (Config. B)	45.4	45.7	45.0	48.4	40.8	29.3	52.7

Configuration A

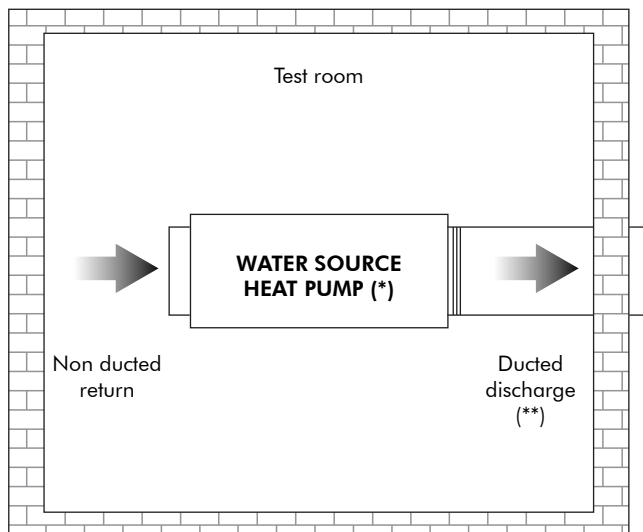

(*) Unit suspended at 1 metre from ground.
 (**) 1.5 metre long acoustic duct.

Configuration B

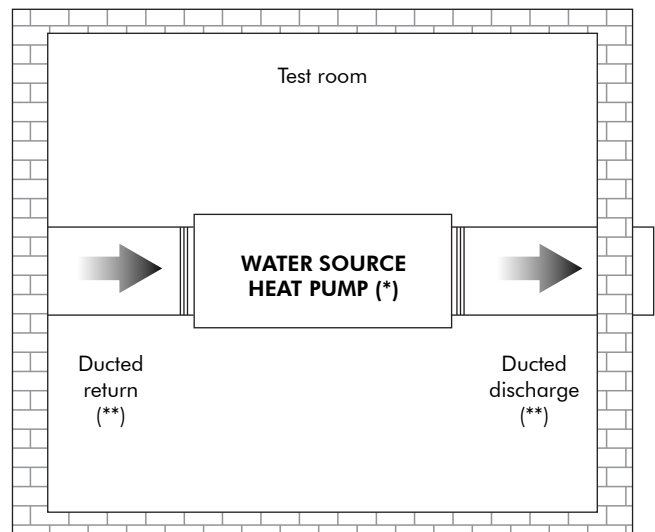

(*) Unit suspended at 1 metre from ground.
 (**) 1.5 metre long acoustic duct.

Acoustical Data (continued)

Sound Power Levels Lw - HRW 036

Speeds	Type	Frequency						Global dB(A)
		125 Hz	250 Hz	500 Hz	1k Hz	2k Hz	4k Hz	
HS	Lw radiated inlet + casing (Config. A)	53.2	56.1	58.7	61.6	58.1	50.9	65.6
	Lw radiated casing only (Config. B)	49.5	50.5	52.7	52.0	49.9	42.1	58.2
MS	Lw radiated inlet + casing (Config. A)	52.6	52.6	56.3	58.3	54.5	47.2	62.6
	Lw radiated casing only (Config. B)	48.4	47.1	50.5	50.0	45.6	37.2	55.7
LS	Lw radiated inlet + casing (Config. A)	49.4	50.4	54.4	55.0	49.3	40.7	59.5
	Lw radiated casing only (Config. B)	46.9	44.6	47.1	46.9	40.1	30.1	52.8

Sound Power Levels Lw - HRW 042

Speeds	Type	Frequency						Global dB(A)
		125 Hz	250 Hz	500 Hz	1k Hz	2k Hz	4k Hz	
HS	Lw radiated inlet + casing (Config. A)	53.7	57.6	60.8	63.6	60.7	54.2	67.6
	Lw radiated casing only (Config. B)	47.7	51.2	52.9	52.6	49.2	43.6	58.3
MS	Lw radiated inlet + casing (Config. A)	52.6	55.8	58.7	60.7	58.8	52.7	65.3
	Lw radiated casing only (Config. B)	47.1	49.3	51.1	49.6	46.2	40.1	56.1
LS	Lw radiated inlet + casing (Config. A)	49.5	55.7	56.5	56.6	53.0	46.5	62.1
	Lw radiated casing only (Config. B)	45.7	48.4	48.6	47.4	41.6	36.7	54.0

Sound Power Levels Lw - HRW 048 and 060

Speeds	Type	Frequency						Global dB(A)
		125 Hz	250 Hz	500 Hz	1k Hz	2k Hz	4k Hz	
HS	Lw radiated inlet + casing (Config. A)	56.8	62.6	65.0	66.9	65.4	58.5	71.6
	Lw radiated casing only (Config. B)	52.2	57.3	57.1	56.9	52.9	46.5	62.9
MS	Lw radiated inlet + casing (Config. A)	54.4	58.8	62.8	63.6	62.2	54.8	68.6
	Lw radiated casing only (Config. B)	48.3	51.7	53.2	52.8	49.5	43.2	58.6
LS	Lw radiated inlet + casing (Config. A)	50.8	55.3	60.1	59.1	57.7	49.3	64.7
	Lw radiated casing only (Config. B)	46.1	48.4	51.1	48.6	44.8	35.3	55.4

Configuration A

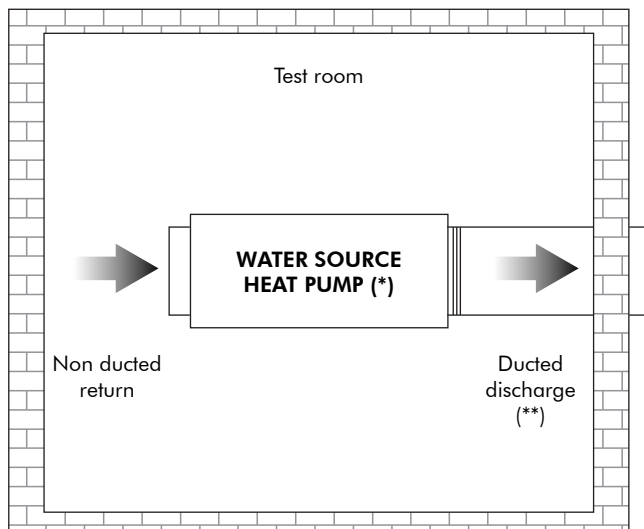

(*) Unit suspended at 1 metre from ground.
 (**) 1.5 metre long acoustic duct.

Configuration B

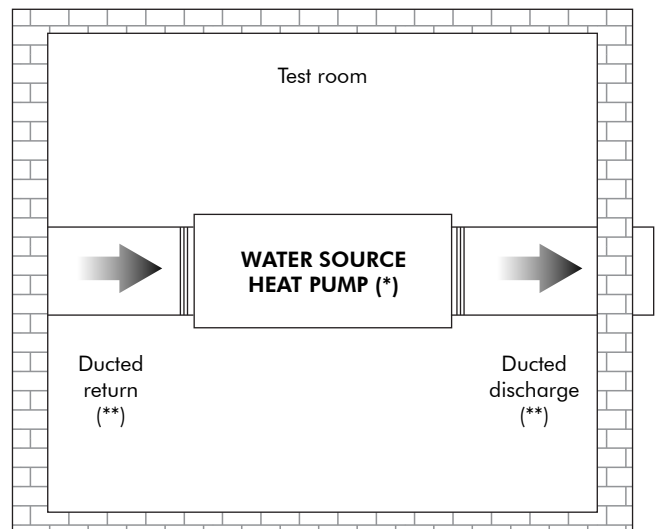

(*) Unit suspended at 1 metre from ground.
 (**) 1.5 metre long acoustic duct.

Acoustical Data (continued)

Sound Power Levels Lw - HRW 072

Speeds	Type	Frequency						Global dB(A)
		125 Hz	250 Hz	500 Hz	1 kHz	2 kHz	4 kHz	
HS	Lw radiated inlet + casing (Config. A)	57.4	62.7	64.5	65.1	61.8	58.9	70.3
	Lw radiated casing only (Config. B)	54.4	55.7	56.5	58.6	53.8	46.7	63.2
MS	Lw radiated inlet + casing (Config. A)	56.7	58.3	60.1	59.8	56.9	52.4	65.8
	Lw radiated casing only (Config. B)	53.5	51.7	53.7	53.6	49.4	41.1	59.7
LS	Lw radiated inlet + casing (Config. A)	54.8	54.5	56.8	56.0	53.0	46.6	62.3
	Lw radiated casing only (Config. B)	52.7	49.7	51.3	49.2	44.4	38.2	57.3

Sound Power Levels Lw - HRW 096

Speeds	Type	Frequency						Global dB(A)
		125 Hz	250 Hz	500 Hz	1 kHz	2 kHz	4 kHz	
0 turn	Lw radiated inlet + casing (Config. A)	62.7	67.2	71.9	76.8	71.5	69.1	79.7
	Lw radiated casing only (Config. B)	59.1	62.1	63.4	67.2	60.9	54.8	70.6
1 turn	Lw radiated inlet + casing (Config. A)	62.0	65.9	70.5	75.0	70.8	68.3	78.3
	Lw radiated casing only (Config. B)	58.5	61.2	62.7	66.4	60.1	54.6	69.8
2 turns	Lw radiated inlet + casing (Config. A)	62.4	65.2	70.8	74.9	70.0	67.3	78.0
	Lw radiated casing only (Config. B)	57.8	60.4	62.0	65.1	58.6	52.7	68.7
3 turns	Lw radiated inlet + casing (Config. A)	60.3	64.2	69.9	73.1	68.6	65.5	76.5
	Lw radiated casing only (Config. B)	56.4	59.4	61.2	64.3	57.7	51.7	67.8

Sound Power Levels Lw - HRW 120

Speeds	Type	Frequency						Global dB(A)
		125 Hz	250 Hz	500 Hz	1 kHz	2 kHz	4 kHz	
0 turn	Lw radiated inlet + casing (Config. A)	68.1	70.9	73.9	76.5	73.6	67.0	80.6
	Lw radiated casing only (Config. B)	62.9	64.9	66.2	67.1	61.0	53.3	72.0
1 turn	Lw radiated inlet + casing (Config. A)	66.5	69.2	73.1	74.3	71.9	65.2	79.0
	Lw radiated casing only (Config. B)	62.9	64.9	65.6	66.7	60.1	52.5	71.6
2 turns	Lw radiated inlet + casing (Config. A)	65.8	68.1	72.2	73.3	70.8	63.7	78.0
	Lw radiated casing only (Config. B)	62.2	62.3	63.4	63.8	57.2	49.5	69.3
3 turns	Lw radiated inlet + casing (Config. A)	65.9	66.6	68.4	71.3	67.7	60.3	75.6
	Lw radiated casing only (Config. B)	61.0	61.2	64.0	64.5	57.8	51.4	69.4

Configuration A

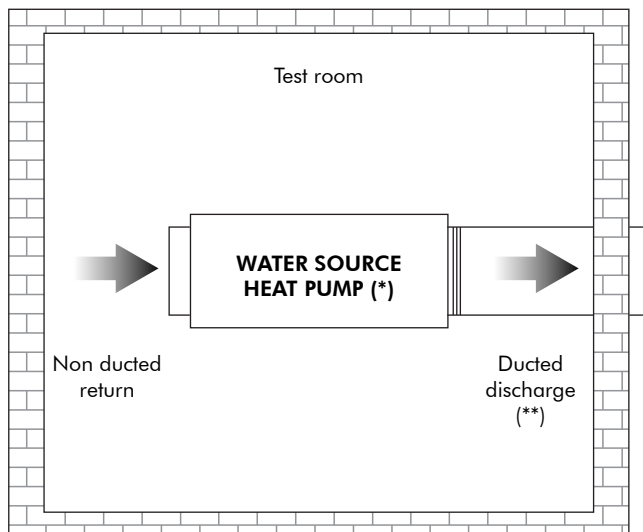

(*) Unit suspended at 1 metre from ground.
 (**) 1.5 metre long acoustic duct.

Configuration B

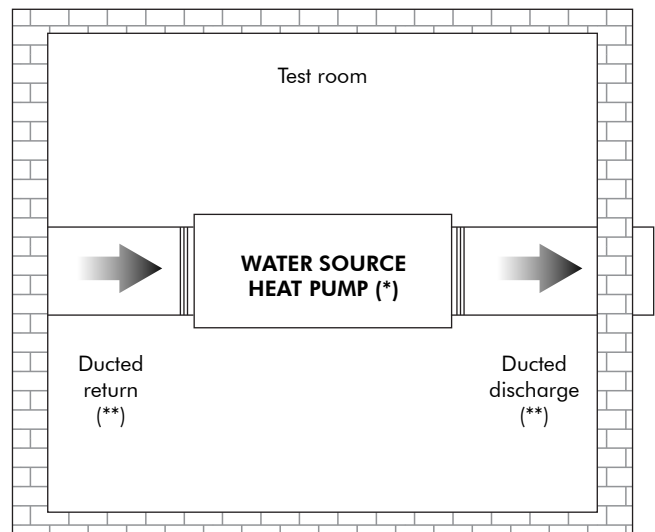

(*) Unit suspended at 1 metre from ground.
 (**) 1.5 metre long acoustic duct.

Cooling Performance Data - HRW 007

Nominal Airflow 440 m³/h

Entering Water Temp. (°C)	Water flow (l/s)	Water Pressure Drop (kPa)	Cooling mode						
			TEA (°C)	TSE (°C)	Pt (W)	Ps (W)	Pabs (W)	CR (W)	EER
13	0.1167	1.3	24/17	18.3	2093	1510	429	2522	4.88
			27/19	18.5	2181	1563	432	2613	5.05
			30/21	18.8	2253	1605	438	2691	5.14
	0.088	0.73	24/17	19.9	2055	1490	433	2488	4.75
			27/19	20.2	2147	1546	435	2582	4.94
			30/21	20.6	2211	1603	440	2651	5.03
16	0.1167	1.3	24/17	21.2	2031	1487	438	2469	4.64
			27/19	21.4	2112	1529	444	1973	4.76
			30/21	21.7	2241	1605	446	2051	5.02
	0.088	0.74	24/17	22.9	2010	1478	449	2459	4.48
			27/19	23.2	2090	1519	451	1970	4.63
			30/21	23.7	2189	1576	455	2031	4.81
	0.058	0.32	24/17	26.5	1990	1460	462	1922	4.31
			27/19	27	2080	1526	467	1993	4.45
			30/21	27.3	2165	1588	469	2057	4.62
20	0.1167	1.3	24/17	25.1	1966	1452	468	2434	4.20
			27/19	25.4	2070	1513	469	2539	4.41
			30/21	25.6	2169	1570	475	2644	4.57
	0.088	0.74	24/17	26.8	1941	1441	474	2415	4.09
			27/19	27.1	2051	1506	478	2529	4.29
			30/21	27.5	2150	1573	480	2630	4.48
	0.058	0.32	24/17	30.4	1934	1435	493	2427	3.92
			27/19	30.9	2015	1471	498	2513	4.05
			30/21	31.4	2137	1560	503	2640	4.25
27	0.1167	1.3	24/17	32	1863	1402	522	2385	3.57
			27/19	32.3	1991	1478	523	2514	3.81
			30/21	32.5	2071	1526	524	2595	3.95
	0.088	0.74	24/17	33.6	1849	1392	527	2376	3.51
			27/19	34	1958	1462	531	2489	3.69
			30/21	34.2	2053	1476	532	2585	3.86
	0.058	0.32	24/17	37	1839	1377	554	2393	3.32
			27/19	37.4	1928	1448	561	2489	3.44
			30/21	38.3	2064	1530	563	2627	3.67
30	0.1167	1.3	24/17	34.8	1828	1383	548	2376	3.34
			27/19	35	1941	1441	550	2491	3.53
			30/21	35.4	2046	1518	551	2597	3.71
	0.088	0.74	24/17	36.6	1819	1377	555	2374	3.28
			27/19	37	1927	1430	558	2485	3.45
			30/21	37.2	2030	1515	559	2589	3.63
	0.058	0.32	24/17	40	1778	1361	571	2349	3.11
			27/19	40.8	1891	1432	575	2466	3.29
			30/21	41.4	2011	1507	581	2592	3.46

TEA : Entering air temperature (dry bulb/wet bulb).
TSE : Leaving water temperature.
Pt : Total cooling capacity.

Ps : Sensible cooling capacity.
Pabs : Compressor power input.
CR : Total heat rejection.

Cooling Performance Data - HRW 007 (continued)

Nominal Airflow 440 m³/h

Entering Water Temp. (°C)	Water flow (l/s)	Water Pressure Drop (kPa)	Cooling mode						
			TEA (°C)	TSE (°C)	Pt (W)	Ps (W)	Pabs (W)	CR (W)	EER
32	0.1167	1.3	24/17	37	1801	1370	566	2367	3.18
			27/19	37.3	1921	1445	570	2491	3.37
			30/21	37.4	1971	1481	571	2542	3.45
	0.088	0.74	24/17	38.6	1775	1358	573	2348	3.10
			27/19	38.8	1862	1417	578	2440	3.22
			30/21	39.3	1962	1435	581	2543	3.38
	0.058	0.32	24/17	41.9	1731	1333	590	2321	2.93
			27/19	42.4	1834	1410	596	2430	3.08
			30/21	43.1	1940	1453	600	2540	3.23
38	0.1167	1.3	24/17	42.9	1710	1326	625	2335	2.74
			27/19	43	1809	1395	627	2436	2.89
			30/21	43.5	1914	1408	630	2544	3.04
	0.088	0.74	24/17	44.6	1703	1326	634	2337	2.69
			27/19	44.9	1802	1395	637	2439	2.83
			30/21	45	1906	1468	640	2546	2.98
	0.058	0.32	24/17	47.7	1649	1295	645	2294	2.56
			27/19	48.4	1754	1373	650	2404	2.70
			30/21	48.7	1836	1410	658	2494	2.79
40	0.1167	1.3	24/17	44.9	1668	1310	637	2305	2.62
			27/19	45.1	1747	1374	641	2388	2.73
			30/21	45.3	1874	1440	644	2518	2.91
	0.088	0.74	24/17	46.5	1644	1290	646	2290	2.54
			27/19	46.8	1733	1356	648	2381	2.67
			30/21	47	1851	1434	650	2501	2.85
	0.058	0.32	24/17	49.8	1612	1280	662	2274	2.44
			27/19	50.2	1718	1350	667	2385	2.58
			30/21	51	1814	1410	673	2487	2.70
45	0.1167	1.3	24/17	49.8	1579	1266	688	2267	2.30
			27/19	50	1664	1320	693	2357	2.40
			30/21	50.3	1775	1398	695	2470	2.55
	0.088	0.74	24/17	51.4	1563	1254	697	2260	2.24
			27/19	51.7	1647	1319	699	2346	2.36
			30/21	52	1746	1380	703	2449	2.48
	0.058	0.32	24/17	54.6	1526	1233	712	2238	2.14
			27/19	55	1611	1300	718	2329	2.24
			30/21	55.1	1697	1360	723	2420	2.35

TEA : Entering air temperature (dry bulb/wet bulb).

TSE : Leaving water temperature.

Pt : Total cooling capacity.

Ps : Sensible cooling capacity.

Pabs : Compressor power input.

CR : Total heat rejection.

Heating Performance Data - HRW 007

Nominal Airflow 440 m³/h

Entering Water Temp. (°C)	Water flow (l/s)	Water Pressure Drop (kPa)	Heating mode				
			TEA (°C)	Pc (W)	Pabs (W)	CA (W)	COP
13	0.1167	1.3	16	2312	522	1790	4.43
			20	2284	558	1726	4.09
			27	2254	625	1629	3.61
	0.088	0.73	16	2247	517	1730	4.35
			20	2235	550	1685	4.06
			27	2210	616	1594	3.59
16	0.1167	1.3	16	2451	536	1915	4.57
			20	2447	572	1875	4.28
			27	2417	643	1774	3.76
	0.088	0.74	16	2394	531	1863	4.51
			20	2379	567	1812	4.20
			27	2353	635	1718	3.71
	0.058	0.32	16	2271	519	1752	4.38
			20	2260	554	1706	4.08
			27	2241	622	1619	3.60
20	0.1167	1.3	16	2740	552	2188	4.96
			20	2656	590	2066	4.50
			27	2617	663	1954	3.95
	0.088	0.74	16	2595	547	2048	4.74
			20	2578	585	1993	4.41
			27	2545	657	1888	3.87
	0.058	0.32	16	2471	536	1935	4.61
			20	2459	574	1885	4.28
			27	2422	645	1777	3.76
27	0.1167	1.3	16	3061	565	2496	5.42
			20	3036	609	2427	4.99
			27	2987	689	2298	4.34
	0.088	0.74	16	2967	563	2404	5.27
			20	2942	607	2335	4.85
			27	2902	685	2217	4.24
	0.058	0.32	16	2806	557	2249	5.04
			20	2784	599	2185	4.65
			27	2757	676	2081	4.08
30	0.1167	1.3	16	3182	547	2635	5.82
			20	3145	580	2565	5.42
			27	3089	671	2418	4.60
	0.088	0.74	16	3083	547	2536	5.64
			20	3047	581	2466	5.24
			27	3002	672	2330	4.47
	0.058	0.32	16	2932	577	2355	5.08
			20	2894	587	2307	4.93
			27	2857	666	2191	4.29
32	0.1167	1.3	16	3298	543	2755	6.07
			20	3260	587	2673	5.55
			27	3196	671	2525	4.76
	0.088	0.74	16	3190	546	2644	5.84
			20	3160	589	2571	5.37
			27	3107	672	2435	4.62
	0.058	0.32	16	2995	548	2447	5.47
			20	2984	590	2394	5.06
			27	2947	672	2275	4.39

TEA : Entering air temperature.
Pc : Heating capacity.

Pabs : Compressor power input.
CA : Total heat absorption.

Cooling Performance Data - HRW 009

Nominal Airflow 520 m³/h

Entering Water Temp. (°C)	Water flow (l/s)	Water Pressure Drop (kPa)	Cooling mode						
			TEA (°C)	TSE (°C)	Pt (W)	Ps (W)	Pabs (W)	CR (W)	EER
13	0.14	2	24/17	17.9	2428	1820	443	2871	5.48
			27/19	18.2	2610	1912	445	3055	5.87
			30/21	18.5	2790	2022	447	3237	6.24
	0.105	1.2	24/17	19.5	2407	1811	444	2851	5.42
			27/19	19.9	2580	1899	448	3028	5.76
			30/21	20.3	2760	2010	453	3213	6.09
16	0.14	2	24/17	20.9	2377	1796	464	2841	5.12
			27/19	21.2	2565	1889	468	3033	5.48
			30/21	21.5	2731	1999	475	3206	5.75
	0.105	1.2	24/17	22.5	2364	1787	470	2834	5.03
			27/19	22.9	2545	1880	475	3020	5.36
			30/21	23.3	2700	1988	480	3180	5.63
	0.07	0.5	24/17	25.7	2354	1772	484	2838	4.86
			27/19	26.3	2505	1863	491	2996	5.10
			30/21		2683	1970	493	3176	5.44
20	0.14	2	24/17	24.8	2332	1773	495	2827	4.71
			27/19	25.1	2494	1855	500	2994	4.99
			30/21	25.4	2664	1972	517	3181	5.15
	0.105	1.2	24/17	26.4	2306	1760	501	2807	4.60
			27/19	26.8	2481	1846	507	2988	4.89
			30/21	27.2	2652	1962	510	3162	5.20
	0.07	0.5	24/17	29.6	2288	1749	514	2802	4.45
			27/19	30.2	2450	1833	522	2972	4.69
			30/21	30.7	2603	1938	525	3128	4.96
27	0.14	2	24/17	31.8	2226	1718	555	2781	4.01
			27/19	32	2378	1798	562	2940	4.23
			30/21	32.3	2529	1906	565	3094	4.48
	0.105	1.2	24/17	33.3	2212	1716	561	2773	3.94
			27/19	33.7	2358	1788	571	2929	4.13
			30/21	34	2497	1894	576	3073	4.34
	0.07	0.5	24/17	36.5	2182	1703	577	2759	3.78
			27/19	37	2332	1770	586	2918	3.98
			30/21	37.5	2481	1880	591	3072	4.20
30	0.14	2	24/17	34.8	2176	1698	583	2759	3.73
			27/19	35	2338	1770	594	2932	3.94
			30/21	35.3	2478	1880	595	3073	4.16
	0.105	1.2	24/17	36.3	2167	1691	590	2757	3.67
			27/19	36.6	2322	1760	599	2921	3.88
			30/21	37	2469	1873	603	3072	4.09
	0.07	0.5	24/17	39.4	2136	1677	606	2742	3.52
			27/19	40	2282	1757	618	2900	3.69
			30/21	40.5	2424	1863	624	3048	3.88

TEA : Entering air temperature (dry bulb/wet bulb).
TSE : Leaving water temperature.
Pt : Total cooling capacity.

Ps : Sensible cooling capacity.
Pabs : Compressor power input.
CR : Total heat rejection.

Cooling Performance Data - HRW 009 (continued)

Nominal Airflow 520 m³/h

Entering Water Temp. (°C)	Water flow (l/s)	Water Pressure Drop (kPa)	Cooling mode						
			TEA (°C)	TSE (°C)	Pt (W)	Ps (W)	Pabs (W)	CR (W)	EER
32	0.14	2	24/17	36.7	2132	1673	603	2735	3.54
			27/19	37	2303	1764	612	2915	3.76
			30/21	37.3	2436	1860	616	3052	3.95
	0.105	1.2	24/17	38.3	2125	1667	611	2736	3.48
			27/19	38.6	2288	1762	620	2908	3.69
			30/21	39	2430	1856	624	3054	3.89
	0.07	0.5	24/17	41.3	2122	1665	625	2747	3.40
			27/19	41.9	2239	1735	638	2877	3.51
			30/21	42.5	2390	1840	645	3035	3.71
38	0.14	2	24/17	42.6	2040	1630	665	2705	3.07
			27/19	42.9	2193	1713	676	2869	3.24
			30/21	43.2	2336	1824	681	3017	3.43
	0.105	1.2	24/17	44.2	2030	1622	672	2702	3.02
			27/19	44.6	2180	1701	686	2866	3.18
			30/21	44.9	2317	1809	691	3008	3.35
	0.07	0.5	24/17	47.2	2017	1615	689	2706	2.93
			27/19	47.8	2142	1683	704	2846	3.04
			30/21	48.3	2281	1794	712	2993	3.20
40	0.14	2	24/17	44.6	2008	1605	688	2696	2.92
			27/19	44.9	2160	1699	699	2859	3.09
			30/21	45.1	2279	1792	705	2984	3.23
	0.105	1.2	24/17	46.2	1995	1606	695	2690	2.87
			27/19	46.5	2131	1688	707	2838	3.01
			30/21	46.9	2276	1790	715	2991	3.18
	0.07	0.5	24/17	49.2	1968	1595	712	2680	2.76
			27/19	49.7	2110	1672	726	2836	2.91
			30/21	50	2206	1760	729	2935	3.03
45	0.14	2	24/17	49.6	1917	1566	748	2665	2.56
			27/19	49.9	2061	1646	758	2819	2.72
			30/21	50.1	2178	1739	765	2943	2.85
	0.105	1.2	24/17	51.1	1907	1557	755	2662	2.53
			27/19	51.5	2050	1649	768	2818	2.67
			30/21	51.8	2163	1727	775	2938	2.79
	0.07	0.5	24/17	54.1	1874	1543	771	2645	2.43
			27/19	54.6	2021	1625	786	2807	2.57
			30/21	54.9	2105	1714	790	2895	2.66

TEA : Entering air temperature (dry bulb/wet bulb).

TSE : Leaving water temperature.

Pt : Total cooling capacity.

Ps : Sensible cooling capacity.

Pabs : Compressor power input.

CR : Total heat rejection.

Heating Performance Data - HRW 009

Nominal Airflow 520 m³/h

Entering Water Temp. (°C)	Water flow (l/s)	Water Pressure Drop (kPa)	Heating mode				
			TEA (°C)	Pc (W)	Pabs (W)	CA (W)	COP
13	0.14	2	16	2524	532	1992	4.74
			20	2535	575	1960	4.41
			27	2572	655	1917	3.93
	0.105	1.2	16	2284	501	1783	4.56
			20	2264	534	1730	4.24
			27	2236	600	1636	3.73
16	0.14	2	16	2578	535	2043	4.82
			20	2611	578	2033	4.52
			27	2667	667	2000	4.00
	0.105	1.2	16	2471	522	1949	4.73
			20	2481	588	1893	4.22
			27	2416	629	1787	3.84
	0.07	0.5	16	2343	508	1835	4.61
			20	2330	544	1786	4.28
			27	2304	611	1693	3.77
20	0.14	2	16	2814	554	2260	5.08
			20	2784	594	2190	4.69
			27	2743	670	2073	4.09
	0.105	1.2	16	2733	547	2186	5.00
			20	2706	585	2121	4.63
			27	2664	660	2004	4.04
	0.07	0.5	16	2593	533	2060	4.86
			20	2563	571	1992	4.49
			27	2535	644	1891	3.94
27	0.14	2	16	3316	579	2737	5.73
			20	3280	626	2654	5.24
			27	3219	714	2505	4.51
	0.105	1.2	16	3212	576	2636	5.58
			20	3181	622	2559	5.11
			27	3123	706	2417	4.42
	0.07	0.5	16	3021	568	2453	5.32
			20	2988	610	2378	4.90
			27	2957	692	2265	4.27
30	0.14	2	16	3539	584	2955	6.06
			20	3497	633	2864	5.52
			27	3426	725	2701	4.73
	0.105	1.2	16	3436	584	2852	5.88
			20	3389	630	2759	5.38
			27	3326	720	2606	4.62
	0.07	0.5	16	3228	576	2652	5.60
			20	3189	621	2568	5.14
			27	3136	708	2428	4.43
32	0.14	2	16	3691	583	3108	6.33
			20	3646	634	3012	5.75
			27	3569	730	2839	4.89
	0.105	1.2	16	3560	584	2976	6.10
			20	3527	634	2893	5.56
			27	3462	725	2737	4.78
	0.07	0.5	16	3355	582	2773	5.76
			20	3332	629	2703	5.30
			27	3254	717	2537	4.54

TEA : Entering air temperature.
Pc : Heating capacity.

Pabs : Compressor power input.
CA : Total heat absorption.

Cooling Performance Data - HRW 012

Nominal Airflow 650 m³/h

Entering Water Temp. (°C)	Water flow (l/s)	Water Pressure Drop (kPa)	Cooling mode						
			TEA (°C)	TSE (°C)	Pt (W)	Ps (W)	Pabs (W)	CR (W)	EER
13	0.194	3	24/17	17.9	3089	2278	582	3671	5.31
			27/19	18.2	3284	2416	587	3871	5.59
			30/21	18.5	3491	2533	591	4082	5.91
	0.015	1.7	24/17	19.5	3052	2250	588	3640	5.19
			27/19	19.9	3238	2393	596	3834	5.43
			30/21	20.3	3451	2500	600	4051	5.75
16	0.194	3	24/17	20.8	2995	2230	613	3608	4.89
			27/19	21.2	3303	2441	620	3923	5.33
			30/21	21.4	3426	2498	625	4051	5.48
	0.015	1.7	24/17	22.4	2969	2210	619	3588	4.80
			27/19	22.8	3227	2387	626	3853	5.15
			30/21	23.2	3364	2522	629	3993	5.35
	0.097	1	24/17	25.5	2915	2169	632	3547	4.61
			27/19	26.2	3166	2362	642	3808	4.93
			30/21	26.8	3280	2456	645	3925	5.09
20	0.194	3	24/17	25.1	2962	2215	652	3614	4.54
			27/19	25	3111	2319	662	3773	4.70
			30/21	25.3	3314	2450	667	3981	4.97
	0.015	1.7	24/17	26.3	2927	2201	660	3587	4.43
			27/19	26.7	3070	2302	670	3740	4.58
			30/21	27	3281	2427	675	3956	4.86
	0.097	1	24/17	29.5	2886	2197	676	3562	4.27
			27/19	29.9	3023	2267	686	3709	4.41
			30/21	30.6	3228	2400	695	3923	4.64
27	0.194	3	24/17	32	2915	2204	732	3647	3.98
			27/19	32.1	3037	2288	742	3779	4.09
			30/21	32.2	3156	2368	750	3906	4.21
	0.015	1.7	24/17	33.4	2862	2175	741	3603	3.86
			27/19	33.6	2980	2260	751	3731	3.97
			30/21	33.9	3110	2330	759	3869	4.10
	0.097	1	24/17	36.5	2823	2157	759	3582	3.72
			27/19	36.7	2935	2236	772	3707	3.80
			30/21	37.4	3084	2313	782	3866	3.94
30	0.194	3	24/17	34.9	2831	2152	770	3601	3.68
			27/19	35	2974	2253	780	3754	3.81
			30/21	35.1	3102	2356	784	3886	3.96
	0.015	1.7	24/17	36.2	2715	2100	777	3492	3.49
			27/19	36.6	2956	2240	790	3746	3.74
			30/21	36.9	3076	2337	800	3876	3.85
	0.097	1	24/17	39.3	2694	2085	797	3491	3.38
			27/19	39.7	2878	2207	811	3689	3.55
			30/21	40.2	2997	2320	821	3818	3.65

TEA : Entering air temperature (dry bulb/wet bulb).
TSE : Leaving water temperature.
Pt : Total cooling capacity.

Ps : Sensible cooling capacity.
Pabs : Compressor power input.
CR : Total heat rejection.

Cooling Performance Data - HRW 012 (continued)

Nominal Airflow 650 m³/h

Entering Water Temp. (°C)	Water flow (l/s)	Water Pressure Drop (kPa)	Cooling mode						
			TEA (°C)	TSE (°C)	Pt (W)	Ps (W)	Pabs (W)	CR (W)	EER
32	0.194	3	24/17	36.7	2723	2106	797	3520	3.42
			27/19	37	2899	2210	807	3706	3.59
			30/21	37.1	3055	2330	816	3871	3.74
	0.015	1.7	24/17	38.2	2670	2089	805	3475	3.32
			27/19	38.5	2863	2196	818	3681	3.50
			30/21	38.8	3017	2262	825	3842	3.66
	0.097	1	24/17	41.2	2635	2074	821	3456	3.21
			27/19	41.8	2819	2142	836	3655	3.37
			30/21	42.2	2990	2242	849	3839	3.52
38	0.194	3	24/17	42.6	2611	2046	882	3493	2.96
			27/19	42.9	2794	2169	895	3689	3.12
			30/21	43.1	2921	2262	903	3824	3.23
	0.015	1.7	24/17	44.2	2594	2053	890	3484	2.91
			27/19	44.4	2740	2142	905	3645	3.03
			30/21	44.8	2904	2207	914	3818	3.18
	0.097	1	24/17	47.2	2536	2010	909	3445	2.79
			27/19	47.7	2706	2116	923	3629	2.93
			30/21	48.3	2867	2178	935	3802	3.07
40	0.194	3	24/17	44.7	2586	2017	907	3493	2.85
			27/19	44.8	2718	2124	910	3628	2.99
			30/21	45	2841	2236	918	3759	3.09
	0.015	1.7	24/17	46.1	2530	2026	910	3440	2.78
			27/19	46.5	2686	2099	917	3603	2.93
			30/21	46.6	2827	2148	924	3751	3.06
	0.097	1	24/17	49.1	2481	1935	920	3401	2.70
			27/19	49.5	2652	2015	938	3590	2.83
			30/21	49.9	2781	2085	949	3730	2.93
45	0.194	3	24/17	49.6	2447	1884	972	3419	2.52
			27/19	49.7	2572	2031	976	3548	2.64
			30/21	49.9	2700	2106	987	3687	2.74
	0.015	1.7	24/17	51	2410	1879	976	3386	2.47
			27/19	51.3	2550	1989	986	3536	2.59
			30/21	51.5	2666	2079	995	3661	2.68
	0.097	1	24/17	54	2370	1824	1003	3373	2.36
			27/19	54.5	2514	1960	1018	3532	2.47
			30/21	54.7	2637	2046	1024	3661	2.58

TEA : Entering air temperature (dry bulb/wet bulb).

TSE : Leaving water temperature.

Pt : Total cooling capacity.

Ps : Sensible cooling capacity.

Pabs : Compressor power input.

CR : Total heat rejection.

Heating Performance Data - HRW 012

Nominal Airflow 650 m³/h

Entering Water Temp. (°C)	Water flow (l/s)	Water Pressure Drop (kPa)	Heating mode				
			TEA (°C)	Pc (W)	Pabs (W)	CA (W)	COP
13	0.194	3	16	3203	719	2484	4.45
			20	3212	767	2445	4.19
			27	3263	890	2373	3.67
	0.015	1.7	16	3132	706	2426	4.44
			20	3084	757	2327	4.07
			27	3036	856	2180	3.55
16	0.194	3	16	3458	742	2716	4.66
			20	3425	796	2629	4.30
			27	3403	902	2501	3.77
	0.015	1.7	16	3376	731	2645	4.62
			20	3330	786	2544	4.24
			27	3286	889	2397	3.70
	0.097	1	16	3187	715	2472	4.46
			20	3166	767	2399	4.13
			27	3127	866	2261	3.61
20	0.194	3	16	3800	769	3031	4.94
			20	3768	827	2941	4.56
			27	3700	942	2758	3.93
	0.015	1.7	16	3691	760	2931	4.86
			20	3664	817	2847	4.48
			27	3598	929	2669	3.87
	0.097	1	16	3493	744	2749	4.69
			20	3468	799	2669	4.34
			27	3425	910	2515	3.76
27	0.194	3	16	4433	792	3641	5.60
			20	4391	860	3531	5.11
			27	4290	986	3304	4.35
	0.015	1.7	16	4300	790	3510	5.44
			20	4257	858	3399	4.96
			27	4190	978	3212	4.28
	0.097	1	16	4066	780	3286	5.21
			20	4029	845	3184	4.77
			27	3973	966	3007	4.11
30	0.194	3	16	4698	790	3908	5.95
			20	4673	861	3812	5.43
			27	4533	993	3540	4.56
	0.015	1.7	16	4555	789	3766	5.77
			20	4525	860	3665	5.26
			27	4443	990	3453	4.49
	0.097	1	16	4300	785	3515	5.48
			20	4270	857	3413	4.98
			27	4201	980	3221	4.29
32	0.194	3	16	4890	788	4102	6.21
			20	4854	860	3994	5.64
			27	4711	994	3717	4.74
	0.015	1.7	16	4731	786	3945	6.02
			20	4702	854	3848	5.51
			27	4601	990	3611	4.65
	0.097	1	16	4452	780	3672	5.71
			20	4414	850	3564	5.19
			27	4351	988	3363	4.40

TEA : Entering air temperature.
Pc : Heating capacity.

Pabs : Compressor power input.
CA : Total heat absorption.

Cooling Performance Data - HRW 019

Nominal Airflow 1181 m³/h

Entering Water Temp. (°C)	Water flow (l/s)	Water Pressure Drop (kPa)	Cooling mode						
			TEA (°C)	TSE (°C)	Pt (W)	Ps (W)	Pabs (W)	CR (W)	EER
13	0.2792	16	24/17	18.4	5477	4106	943	6420	5.81
			27/19	18.7	5865	4308	934	6799	6.28
			30/21	19	6270	4496	920	7190	6.82
	0.2094	10	24/17	20.2	5437	4086	960	6397	5.66
			27/19	20.6	5818	4277	955	6773	6.09
			30/21	21	6223	4466	943	7166	6.60
16	0.2792	16	24/17	21.3	5365	4042	992	6357	5.41
			27/19	21.6	5754	4248	985	6739	5.84
			30/21	22	6163	4443	973	7136	6.33
	0.2094	10	24/17	23.1	5332	4031	1011	6343	5.27
			27/19	23.5	5706	4229	1008	6714	5.66
			30/21	23.9	6115	4428	998	7113	6.13
	0.1396	5	24/17	26.6	5258	3992	1052	6310	5.00
			27/19	27.2	5613	4181	1054	6667	5.33
			30/21	27.8	6013	4377	1050	7063	5.73
20	0.2792	16	24/17	25.3	5222	3967	1062	6284	4.92
			27/19	25.6	5600	4172	1059	6659	5.29
			30/21	25.9	6014	4378	1050	7064	5.73
	0.2094	10	24/17	27	5178	3946	1082	6260	4.79
			27/19	27.4	5561	4159	1081	6642	5.14
			30/21	27.8	5964	4344	1075	7039	5.55
	0.1396	5	24/17	30.5	5095	3904	1125	6220	4.53
			27/19	31	5460	4105	1129	6589	4.84
			30/21	31.6	5856	4286	1129	6985	5.19
27	0.2792	16	24/17	32.2	5045	3839	1191	6236	4.24
			27/19	32.5	5400	4046	1193	6593	4.53
			30/21	31.7	5735	4211	1186	6921	4.84
	0.2094	10	24/17	33.9	5004	3809	1213	6217	4.13
			27/19	34.3	5357	4015	1217	6574	4.40
			30/21	34.7	5689	4183	1213	6902	4.69
	0.1396	5	24/17	37.3	4910	3758	1261	6171	3.89
			27/19	37.8	5252	3956	1268	6520	4.14
			30/21	38.4	5573	4147	1272	6845	4.38
30	0.2792	16	24/17	35.1	4926	3770	1253	6179	3.93
			27/19	35.4	5278	3978	1257	6535	4.20
			30/21	35.7	5614	4152	1254	6868	4.48
	0.2094	10	24/17	36.8	4934	3757	1276	6210	3.87
			27/19	37.2	5235	3968	1282	6517	4.08
			30/21	37.6	5560	4138	1282	6842	4.34
	0.1396	5	24/17	40.2	4805	3718	1324	6129	3.63
			27/19	40.7	5137	3919	1335	6472	3.85
			30/21	41.3	5434	4071	1341	6775	4.05

TEA : Entering air temperature (dry bulb/wet bulb).
TSE : Leaving water temperature.
Pt : Total cooling capacity.

Ps : Sensible cooling capacity.
Pabs : Compressor power input.
CR : Total heat rejection.

Cooling Performance Data - HRW 019 (continued)

Nominal Airflow 1181 m³/h

Entering Water Temp. (°C)	Water flow (l/s)	Water Pressure Drop (kPa)	Cooling mode						
			TEA (°C)	TSE (°C)	Pt (W)	Ps (W)	Pabs (W)	CR (W)	EER
32	0.2792	16	24/17	37.1	4851	3732	1296	6147	3.74
			27/19	37.4	5200	3943	1300	6500	4.00
			30/21	37.7	5526	4113	1300	6826	4.25
	0.2094	10	24/17	38.8	4810	3721	1317	6127	3.65
			27/19	39.2	5146	3825	1325	6471	3.88
			30/21	39.6	5441	4052	1327	6768	4.10
	0.1396	5	24/17	42.1	4728	3682	1366	6094	3.46
			27/19	42.7	5050	3877	1379	6429	3.66
			30/21	43.2	5362	4045	1387	6749	3.87
38	0.2792	16	24/17	43.1	4651	3602	1433	6084	3.25
			27/19	43.3	4973	3810	1441	6414	3.45
			30/21	43.6	5317	3987	1457	6774	3.65
	0.2094	10	24/17	44.7	4601	3565	1457	6058	3.16
			27/19	45.1	4882	3765	1468	6350	3.33
			30/21	45.4	5258	3971	1474	6732	3.57
	0.1396	5	24/17	48.7	4501	3534	1507	6008	2.99
			27/19	48.5	4845	3738	1522	6367	3.18
			30/21	49.1	5147	3921	1536	6683	3.35
40	0.2792	16	24/17	45	4589	3577	1480	6069	3.10
			27/19	45.3	4871	3758	1488	6359	3.27
			30/21	45.6	5193	3922	1494	6687	3.48
	0.2094	10	24/17	46.7	4551	3549	1503	6054	3.03
			27/19	47	4827	3726	1515	6342	3.19
			30/21	47.3	5090	3950	1516	6606	3.36
	0.1396	5	24/17	49.9	4463	3506	1552	6015	2.88
			27/19	50.5	4715	3665	1571	6286	3.00
			30/21	51.1	5015	3861	1578	6593	3.18
45	0.2792	16	24/17	49.9	4384	3469	1599	5983	2.74
			27/19	50.2	4647	3641	1614	6261	2.88
			30/21	20.5	4947	3841	1615	6562	3.06
	0.2094	10	24/17	51.5	4314	3439	1621	5935	2.66
			27/19	51.9	4596	3633	1640	6236	2.80
			30/21	52.2	4790	3833	1645	6435	2.91
	0.1396	5	24/17	54.7	4248	3411	1669	5917	2.55
			27/19	55.3	4499	3586	1695	6194	2.65
			30/21	55.9	4700	3780	1700	6400	2.76

TEA : Entering air temperature (dry bulb/wet bulb).

TSE : Leaving water temperature.

Pt : Total cooling capacity.

Ps : Sensible cooling capacity.

Pabs : Compressor power input.

CR : Total heat rejection.

Heating Performance Data - HRW 019

Nominal Airflow 1181 m³/h

Entering Water Temp. (°C)	Water flow (l/s)	Water Pressure Drop (kPa)	Heating mode				
			TEA (°C)	Pc (W)	Pabs (W)	CA (W)	COP
13	0.2792	16	16	5066	1140	3926	4.44
			20	5006	1218	3788	4.11
			27	4973	1372	3601	3.62
	0.2094	10	16	4942	1124	3818	4.40
			20	4888	1201	3687	4.07
			27	4781	1339	3442	3.57
16	0.2792	16	16	5425	1186	4239	4.57
			20	5357	1267	4090	4.23
			27	5235	1415	3820	3.70
	0.2094	10	16	5290	1170	4120	4.52
			20	5228	1250	3978	4.18
			27	5103	1392	3711	3.67
	0.1396	5	16	5039	1138	3901	4.43
			20	4988	1217	3771	4.10
			27	4887	1357	3530	3.60
20	0.2792	16	16	5911	1239	4672	4.77
			20	5826	1325	4501	4.40
			27	5699	1484	4215	3.84
	0.2094	10	16	5745	1221	4524	4.71
			20	5688	1310	4378	4.34
			27	5558	1463	4095	3.80
	0.1396	5	16	5472	1192	4280	4.59
			20	5412	1274	4138	4.25
			27	5304	1425	3879	3.72
27	0.2792	16	16	6747	1320	5427	5.11
			20	6649	1416	5233	4.70
			27	6469	1585	4884	4.08
	0.2094	10	16	6542	1302	5240	5.02
			20	6456	1396	5060	4.62
			27	6309	1568	4741	4.02
	0.1396	5	16	6191	1272	4919	4.87
			20	6120	1363	4757	4.49
			27	5995	1526	4469	3.93
30	0.2792	16	16	7142	1344	5798	5.31
			20	7032	1443	5589	4.87
			27	6846	1623	5223	4.22
	0.2094	10	16	6926	1331	5595	5.20
			20	6826	1428	5398	4.78
			27	6660	1605	5055	4.15
	0.1396	5	16	6545	1302	5243	5.03
			20	6463	1396	5067	4.63
			27	6332	1569	4763	4.04
32	0.2792	16	16	7412	1356	6056	5.47
			20	7306	1463	5843	4.99
			27	7106	1647	5459	4.31
	0.2094	10	16	7191	1347	5844	5.34
			20	7100	1452	5648	4.89
			27	6920	1632	5288	4.24
	0.1396	5	16	6779	1319	5460	5.14
			20	6707	1420	5287	4.72
			27	6559	1595	4964	4.11

TEA : Entering air temperature.
Pc : Heating capacity.

Pabs : Compressor power input.
CA : Total heat absorption.

Cooling Performance Data - HRW 024

Nominal Airflow 1312 m³/h

Entering Water Temp. (°C)	Water flow (l/s)	Water Pressure Drop (kPa)	Cooling mode						
			TEA (°C)	TSE (°C)	Pt (W)	Ps (W)	Pabs (W)	CR (W)	EER
13	0.3503	19	24/17	17.9	6182	4651	1326	7508	4.66
			27/19	18.2	6677	4911	1331	8008	5.02
			30/21	18.6	7162	5144	1331	8493	5.38
	0.2627	11	24/17	19.5	6139	4632	1345	7484	4.56
			27/19	19.9	6625	4896	1352	7977	4.90
			30/21	20.4	7111	5127	1355	8466	5.25
16	0.3503	19	24/17	20.8	6052	4584	1389	7441	4.36
			27/19	21.2	6519	4838	1396	7915	4.67
			30/21	21.5	7015	5079	1398	8413	5.02
	0.2627	11	24/17	22.4	6019	4561	1407	7426	4.28
			27/19	22.9	6435	4788	1418	7853	4.54
			30/21	23.3	6966	5050	1423	8389	4.90
	0.1751	5	24/17	25.5	5939	4518	1449	7388	4.10
			27/19	26.2	6383	4759	1467	7850	4.35
			30/21	26.9	6857	4994	1479	8336	4.64
20	0.3503	19	24/17	24.8	5882	4478	1478	7360	3.98
			27/19	25.1	6338	4737	1489	7827	4.26
			30/21	25.4	6823	4965	1494	8317	4.57
	0.2627	11	24/17	26.3	5844	4463	1497	7341	3.90
			27/19	26.8	6264	4686	1511	7775	4.15
			30/21	27.2	6769	4942	1519	8288	4.46
	0.1751	5	24/17	29.4	5770	4424	1540	7310	3.75
			27/19	30.1	6207	4661	1560	7767	3.98
			30/21	30.7	6668	4872	1574	8242	4.24
27	0.3503	19	24/17	31.7	5634	4323	1643	7277	3.43
			27/19	32	6081	4566	1659	7740	3.67
			30/21	32.3	6539	4823	1668	8207	3.92
	0.2627	11	24/17	33.2	5601	4300	1665	7266	3.36
			27/19	33.7	6039	4566	1685	7724	3.58
			30/21	34.1	6484	4784	1696	8180	3.82
	0.1751	5	24/17	36.3	5513	4251	1712	7225	3.22
			27/19	36.9	5946	4499	1736	7682	3.43
			30/21	37.5	6370	4717	1756	8126	3.63
30	0.3503	19	24/17	34.6	5507	4232	1722	7229	3.20
			27/19	34.9	5923	4502	1737	7660	3.41
			30/21	35.3	6371	4718	1751	8122	3.64
	0.2627	11	24/17	36.2	5463	4216	1742	7205	3.14
			27/19	36.6	5884	4463	1764	7648	3.34
			30/21	37	6322	4704	1780	8102	3.55
	0.1751	5	24/17	39.2	5391	4180	1789	7180	3.01
			27/19	39.8	5789	4415	1817	7606	3.19
			30/21	40.4	6216	4652	1839	8055	3.38

TEA : Entering air temperature (dry bulb/wet bulb).
TSE : Leaving water temperature.
Pt : Total cooling capacity.

Ps : Sensible cooling capacity.
Pabs : Compressor power input.
CR : Total heat rejection.

Cooling Performance Data - HRW 024 (continued)

Nominal Airflow 1312 m³/h

Entering Water Temp. (°C)	Water flow (l/s)	Water Pressure Drop (kPa)	Cooling mode						
			TEA (°C)	TSE (°C)	Pt (W)	Ps (W)	Pabs (W)	CR (W)	EER
32	0.3503	19	24/17	36.6	5409	4177	1773	7182	3.05
			27/19	36.9	5823	4439	1794	7617	3.25
			30/21	37.2	6297	4704	1809	8106	3.48
	0.2627	11	24/17	38.1	5377	4170	1797	7174	2.99
			27/19	38.5	5783	4410	1818	7601	3.18
			30/21	39	6223	4657	1837	8060	3.39
	0.1751	5	24/17	41.1	5272	4106	1844	7116	2.86
			27/19	41.7	5684	4359	1871	7555	3.04
			30/21	42.3	6123	4614	1896	8019	3.23
38	0.3503	19	24/17	42.5	5170	4027	1943	7113	2.66
			27/19	42.8	5583	4296	1965	7548	2.84
			30/21	43.1	5972	4515	1983	7955	3.01
	0.2627	11	24/17	44	5156	4031	1967	7123	2.62
			27/19	44.4	5538	4261	1992	7530	2.78
			30/21	44.8	5950	4500	2014	7964	2.95
	0.1751	5	24/17	47	5078	3988	2015	7093	2.52
			27/19	47.6	5444	4217	2048	7492	2.66
			30/21	48.2	5843	4458	2076	7919	2.81
40	0.3503	19	24/17	44.5	5093	4000	2000	7093	2.55
			27/19	44.8	5481	4243	2025	7506	2.71
			30/21	45.1	5908	4502	2046	7954	2.89
	0.2627	11	24/17	46	5059	3974	2022	7081	2.50
			27/19	46.4	5434	4210	2052	7486	2.65
			30/21	46.8	5855	4465	2076	7931	2.82
	0.1751	5	24/17	48.9	4973	3926	2072	7045	2.40
			27/19	49.5	5343	4171	2108	7451	2.53
			30/21	50.1	5758	4424	2137	7895	2.69
45	0.3503	19	24/17	49.4	4842	3844	2151	6993	2.25
			27/19	49.7	5222	4111	2181	7403	2.39
			30/21	50	5602	4348	2206	7808	2.54
	0.2627	11	24/17	50.8	4802	3836	2172	6974	2.21
			27/19	51.2	5176	4104	2206	7382	2.35
			30/21	51.6	5547	4335	2235	7782	2.48
	0.1751	5	24/17	53.7	4730	3785	2223	6953	2.13
			27/19	54.3	5090	4043	2259	7349	2.25
			30/21	54.9	5482	4292	2297	7779	2.39

TEA : Entering air temperature (dry bulb/wet bulb).

TSE : Leaving water temperature.

Pt : Total cooling capacity.

Ps : Sensible cooling capacity.

Pabs : Compressor power input.

CR : Total heat rejection.

Heating Performance Data - HRW 024

Nominal Airflow 1312 m³/h

Entering Water Temp. (°C)	Water flow (l/s)	Water Pressure Drop (kPa)	Heating mode				
			TEA (°C)	Pc (W)	Pabs (W)	CA (W)	COP
13	0.3503	19	16	6298	1669	4629	3.77
			20	6199	1769	4430	3.50
			27	6198	1978	4220	3.13
	0.2627	11	16	6120	1652	4468	3.70
			20	6024	1751	4273	3.44
			27	5850	1932	3918	3.03
16	0.3503	19	16	6799	1721	5078	3.95
			20	6682	1823	4859	3.67
			27	6494	2017	4477	3.22
	0.2627	11	16	6602	1701	4901	3.88
			20	6505	1806	4699	3.60
			27	6321	1995	4326	3.17
	0.1751	5	16	6240	1664	4576	3.75
			20	6150	1764	4386	3.49
			27	5994	1951	4043	3.07
20	0.3503	19	16	7495	1784	5711	4.20
			20	7370	1895	5475	3.89
			27	7157	2100	5057	3.41
	0.2627	11	16	7255	1763	5492	4.12
			20	7145	1872	5273	3.82
			27	6968	2079	4889	3.35
	0.1751	5	16	6850	1725	5125	3.97
			20	6758	1833	4925	3.69
			27	6589	2122	4467	3.11
27	0.3503	19	16	7824	1808	6016	4.33
			20	7692	1917	5775	4.01
			27	7478	2126	5352	3.52
	0.2627	11	16	7557	1784	5773	4.24
			20	7452	1896	5556	3.93
			27	7252	2096	5156	3.46
	0.1751	5	16	7120	1749	5371	4.07
			20	7014	1854	5160	3.78
			27	6850	2051	4799	3.34
30	0.3503	19	16	8370	1846	6524	4.53
			20	8236	1966	6270	4.19
			27	7991	2181	5810	3.66
	0.2627	11	16	8088	1826	6262	4.43
			20	7976	1944	6032	4.10
			27	7763	2157	5606	3.60
	0.1751	5	16	7599	1788	5811	4.25
			20	7497	1900	5597	3.95
			27	7317	2105	5212	3.48
32	0.3503	19	16	8756	1874	6882	4.67
			20	8614	1996	6618	4.32
			27	8369	2219	6150	3.77
	0.2627	11	16	8451	1853	6598	4.56
			20	8340	1977	6363	4.22
			27	8095	2190	5905	3.70
	0.1751	5	16	7922	1815	6107	4.36
			20	7815	1929	5886	4.05
			27	7635	2141	5494	3.57

TEA : Entering air temperature.
Pc : Heating capacity.

Pabs : Compressor power input.
CA : Total heat absorption.

Cooling Performance Data - HRW 030

Nominal Airflow 1490 m³/h

Entering Water Temp. (°C)	Water flow (l/s)	Water Pressure Drop (kPa)	Cooling mode						
			TEA (°C)	TSE (°C)	Pt (W)	Ps (W)	Pabs (W)	CR (W)	EER
13	0.49	23	24/17	17.7	8600	6520	1465	10065	5.87
			27/19	18	9261	6874	1462	10723	6.33
			30/21	18.4	9990	7141	1454	11444	6.87
	0.367	14	24/17	19.3	8528	6480	1497	10025	5.70
			27/19	19.7	9202	6810	1500	10702	6.13
			30/21	20.2	9923	7111	1497	11420	6.63
16	0.49	23	24/17	20.7	8415	6413	1570	9985	5.36
			27/19	21	9091	6750	1569	10660	5.79
			30/21	21.3	9699	7045	1562	11261	6.21
	0.367	14	24/17	22.2	8350	6378	1604	9954	5.21
			27/19	22.7	9044	6720	1608	10652	5.62
			30/21	23.1	9724	6999	1604	11328	6.06
	0.245	7	24/17	25.2	8239	6314	1676	9915	4.92
			27/19	25.9	8908	6643	1691	10599	5.27
			30/21	26.5	9574	6930	1695	11269	5.65
20	0.49	23	24/17	24.8	8462	6299	1729	10191	4.89
			27/19	25.1	9127	6623	1729	10856	5.28
			30/21	25.4	9768	6903	1720	11488	5.68
	0.367	14	24/17	26.3	8408	6275	1767	10175	4.76
			27/19	26.8	9065	6596	1750	10815	5.18
			30/21	27.2	9696	6855	1766	11462	5.49
	0.245	7	24/17	26.4	8307	6221	1845	10152	4.50
			27/19	30	8923	6515	1859	10782	4.80
			30/21	30.7	9523	6780	1865	11388	5.11
27	0.49	23	24/17	31.8	8276	6095	2032	10308	4.07
			27/19	32.1	8896	6421	2035	10931	4.37
			30/21	32.4	9551	6721	2030	11581	4.70
	0.367	14	24/17	33.3	8211	6051	2072	10283	3.96
			27/19	33.7	8822	6379	2082	10904	4.24
			30/21	34.2	9467	6666	2081	11548	4.55
	0.245	7	24/17	36.4	8090	5999	2160	10250	3.75
			27/19	37	8669	6293	2177	10846	3.98
			30/21	37.7	9260	6573	2190	11450	4.23
30	0.49	23	24/17	34.6	8078	5991	2163	10241	3.73
			27/19	34.9	8691	6315	2168	10859	4.01
			30/21	35.3	9268	6541	2168	11436	4.27
	0.367	14	24/17	36.3	8022	5953	2208	10230	3.63
			27/19	36.7	8615	6256	2220	10835	3.88
			30/21	37.1	9192	6514	2224	11416	4.13
	0.245	7	24/17	39.3	7897	5884	2298	10195	3.44
			27/19	39.9	8471	6198	2317	10788	3.66
			30/21	40.5	9074	6459	2333	11407	3.89

TEA : Entering air temperature (dry bulb/wet bulb).
TSE : Leaving water temperature.
Pt : Total cooling capacity.

Ps : Sensible cooling capacity.
Pabs : Compressor power input.
CR : Total heat rejection.

Cooling Performance Data - HRW 030 (continued)

Nominal Airflow 1490 m³/h

Entering Water Temp. (°C)	Water flow (l/s)	Water Pressure Drop (kPa)	Cooling mode						
			TEA (°C)	TSE (°C)	Pt (W)	Ps (W)	Pabs (W)	CR (W)	EER
32	0.49	23	24/17	36.7	7949	5920	2256	10205	3.52
			27/19	37	8541	6226	2266	10807	3.77
			30/21	37.3	9126	6493	2267	11393	4.03
	0.367	14	24/17	38.2	7885	5876	2300	10185	3.43
			27/19	38.6	8477	6202	2314	10791	3.66
			30/21	39.1	9040	6459	2319	11359	3.90
	0.245	7	24/17	41.3	7766	5811	2391	10157	3.25
			27/19	41.8	8337	6128	2412	10749	3.46
			30/21	42.5	8891	6383	2429	11320	3.66
38	0.49	23	24/17	42.6	7563	5702	2346	9909	3.22
			27/19	42.9	8137	6015	2363	10500	3.44
			30/21	43.2	8703	6265	2367	11070	3.68
	0.367	14	24/17	44.1	7508	5664	2392	9900	3.14
			27/19	44.5	8060	5960	2409	10469	3.35
			30/21	44.9	8659	6261	2421	11080	3.58
	0.245	7	24/17	47.1	7380	5593	2482	9862	2.97
			27/19	47.7	7926	5892	2515	10441	3.15
			30/21	48.2	8474	6169	2534	11008	3.34
40	0.49	23	24/17	44.5	7429	5628	2449	9878	3.03
			27/19	44.8	7987	5934	2462	10449	3.24
			30/21	45.1	8588	6214	2474	11062	3.47
	0.367	14	24/17	46.1	7362	5581	2494	9856	2.95
			27/19	46.4	7919	5888	2511	10430	3.15
			30/21	46.8	8476	6170	2526	11002	3.36
	0.245	7	24/17	49	7246	5518	2584	9830	2.80
			27/19	49.6	7783	5839	2615	10398	2.98
			30/21	50.1	8363	6120	2639	11002	3.17
45	0.49	23	24/17	49.4	6851	5555	2955	9806	2.32
			27/19	49.7	7362	5651	2978	10340	2.47
			30/21	50	7932	5950	2988	10920	2.65
	0.367	14	24/17	50.9	6989	5381	2752	9741	2.54
			27/19	51.3	7521	5697	2775	10296	2.71
			30/21	51.7	8076	5962	2794	10870	2.89
	0.245	7	24/17	53.8	6892	5333	2844	9736	2.42
			27/19	54.4	7400	5635	2876	10276	2.57
			30/21	54.9	7953	5907	2906	10859	2.74

TEA : Entering air temperature (dry bulb/wet bulb).

TSE : Leaving water temperature.

Pt : Total cooling capacity.

Ps : Sensible cooling capacity.

Pabs : Compressor power input.

CR : Total heat rejection.

Heating Performance Data - HRW 030

Nominal Airflow 1490 m³/h

Entering Water Temp. (°C)	Water flow (l/s)	Water Pressure Drop (kPa)	Heating mode				
			TEA (°C)	Pc (W)	Pabs (W)	CA (W)	COP
13	0.49	23	16	9177	2228	6949	4.12
			20	9041	2414	6627	3.75
			27	8978	2774	6204	3.24
	0.367	14	16	8942	2205	6737	4.06
			20	8796	2384	6412	3.69
			27	8556	2718	5838	3.15
16	0.49	23	16	9694	2279	7415	4.25
			20	9535	2466	7069	3.87
			27	9355	2810	6545	3.33
	0.367	14	16	9408	2245	7163	4.19
			20	9260	2432	6828	3.81
			27	9000	2774	6226	3.24
	0.245	7	16	8905	2193	6712	4.06
			20	8767	2373	6394	3.69
			27	8565	2713	5852	3.16
20	0.49	23	16	9934	2347	7587	4.23
			20	9759	2536	7223	3.85
			27	9453	2880	6573	3.28
	0.367	14	16	9616	2316	7300	4.15
			20	9459	2503	6956	3.78
			27	9177	2846	6331	3.22
	0.245	7	16	9055	2255	6800	4.02
			20	8925	2441	6484	3.66
			27	8702	2782	5920	3.13
27	0.49	23	16	11710	2474	9236	4.73
			20	11394	2674	8720	4.26
			27	11178	3050	8128	3.66
	0.367	14	16	11323	2451	8872	4.62
			20	11163	2641	8522	4.23
			27	10842	3011	7831	3.60
	0.245	7	16	10676	2381	8295	4.48
			20	10543	2582	7961	4.08
			27	10257	2933	7324	3.50
30	0.49	23	16	11724	2503	9221	4.68
			20	11534	2646	8888	4.36
			27	11206	3070	8136	3.65
	0.367	14	16	11335	2470	8865	4.59
			20	11184	2670	8514	4.19
			27	10868	3032	7836	3.58
	0.245	7	16	10688	2410	8278	4.43
			20	10562	2608	7954	4.05
			27	10301	2961	7340	3.48
32	0.49	23	16	12147	2531	9616	4.80
			20	11922	2720	9202	4.38
			27	11577	3104	8473	3.73
	0.367	14	16	11727	2496	9231	4.70
			20	11548	2698	8850	4.28
			27	11290	3069	8221	3.68
	0.245	7	16	11040	2437	8603	4.53
			20	10896	2636	8260	4.13
			27	10646	3003	7643	3.55

TEA : Entering air temperature.
Pc : Heating capacity.

Pabs : Compressor power input.
CA : Total heat absorption.

Cooling Performance Data - HRW 036

Nominal Airflow 1580 m³/h

Entering Water Temp. (°C)	Water flow (l/s)	Water Pressure Drop (kPa)	Cooling mode						
			TEA (°C)	TSE (°C)	Pt (W)	Ps (W)	Pabs (W)	CR (W)	EER
13	0.564	25	24/17	18	10584	7318	1831	12415	5.78
			27/19	18.4	11478	7775	1830	13308	6.27
			30/21	18.8	12287	8103	1821	14108	6.75
	0.423	15	24/17	19.8	10528	7298	1868	12396	5.64
			27/19	20.2	11396	7724	1871	13267	6.09
			30/21	20.7	12190	8066	1866	14056	6.53
16	0.564	25	24/17	21	10459	7255	1949	12408	5.37
			27/19	21.4	11258	7655	1953	13211	5.76
			30/21	21.7	12069	8014	1946	14015	6.20
	0.423	15	24/17	22.7	10399	7232	1989	12388	5.23
			27/19	23.1	11178	7625	1993	13171	5.61
			30/21	23.6	11982	7960	1991	13973	6.02
	0.282	7	24/17	26	10254	7155	2072	12326	4.95
			27/19	26.6	11030	7551	2089	13119	5.28
			30/21	27.3	11793	7867	2099	13892	5.62
20	0.564	25	24/17	25	10185	7110	2122	12307	4.80
			27/19	25.3	10959	7506	2121	13080	5.17
			30/21	25.6	11748	7863	2118	13866	5.55
	0.423	15	24/17	26.6	10118	7084	2158	12276	4.69
			27/19	27	10888	7461	2168	13056	5.02
			30/21	27.5	11667	7813	2173	13840	5.37
	0.282	7	24/17	29.8	9995	7022	2247	12242	4.45
			27/19	30.5	10728	7402	2265	12993	4.74
			30/21	31.1	11480	7746	2279	13759	5.04
27	0.564	25	24/17	31.9	9822	7075	2441	12263	4.02
			27/19	32.2	10411	7403	2446	12857	4.26
			30/21	32.6	11123	7717	2450	13573	4.54
	0.423	15	24/17	33.5	9749	7049	2486	12235	3.92
			27/19	33.9	10434	7418	2500	12934	4.17
			30/21	34.4	11033	7690	2504	13537	4.41
	0.282	7	24/17	36.7	9602	6973	2586	12188	3.71
			27/19	37.3	10129	7272	2611	12740	3.88
			30/21	38	10798	7570	2628	13426	4.11
30	0.564	25	24/17	34.8	9597	6970	2582	12179	3.72
			27/19	35.2	10138	7278	2593	12731	3.91
			30/21	35.5	10874	7619	2597	13471	4.19
	0.423	15	24/17	36.5	9367	6877	2629	11996	3.56
			27/19	36.9	10061	7228	2645	12706	3.80
			30/21	37.3	10791	7566	2657	13448	4.06
	0.282	7	24/17	39.6	9247	6807	2728	11975	3.39
			27/19	40.2	9959	7188	2755	12714	3.61
			30/21	40.8	10660	7512	2776	13436	3.84

TEA : Entering air temperature (dry bulb/wet bulb).
TSE : Leaving water temperature.
Pt : Total cooling capacity.

Ps : Sensible cooling capacity.
Pabs : Compressor power input.
CR : Total heat rejection.

Cooling Performance Data - HRW 036 (continued)

Nominal Airflow 1580 m³/h

Entering Water Temp. (°C)	Water flow (l/s)	Water Pressure Drop (kPa)	Cooling mode						
			TEA (°C)	TSE (°C)	Pt (W)	Ps (W)	Pabs (W)	CR (W)	EER
32	0.564	25	24/17	36.8	9316	6829	2648	11964	3.52
			27/19	37.1	9983	7204	2662	12645	3.75
			30/21	37.5	10779	7557	2667	13446	4.04
	0.423	15	24/17	38.4	9319	6831	2696	12015	3.46
			27/19	38.8	9967	7193	2710	12677	3.68
			30/21	39.2	10693	7534	2723	13416	3.93
	0.282	7	24/17	41.5	9178	6760	2796	11974	3.28
			27/19	42.1	9861	7152	2822	12683	3.49
			30/21	42.7	10549	7474	2845	13394	3.71
38	0.564	25	24/17	42.7	8576	6473	2776	11352	3.09
			27/19	43	9206	6841	2794	12000	3.29
			30/21	43.3	9903	7179	2806	12709	3.53
	0.423	15	24/17	44.2	8503	6451	2821	11324	3.01
			27/19	44.7	9118	6813	2847	11965	3.20
			30/21	45.1	9810	7118	2866	12676	3.42
	0.282	7	24/17	47.3	8336	6364	2928	11264	2.85
			27/19	47.9	8951	6733	2958	11909	3.03
			30/21	48.5	9620	7065	2993	12613	3.21
40	0.564	25	24/17	44.7	8413	6389	2887	11300	2.91
			27/19	45	9037	6759	2907	11944	3.11
			30/21	45.3	9720	7094	2921	12641	3.33
	0.423	15	24/17	46.2	8350	6374	2938	11288	2.84
			27/19	46.6	8964	6742	2963	11927	3.03
			30/21	47	9630	7072	2981	12611	3.23
	0.282	7	24/17	49.2	8153	6267	3040	11193	2.68
			27/19	49.8	8807	6669	3079	11886	2.86
			30/21	50.4	9445	6948	3109	12554	3.04
45	0.564	25	24/17	49.6	8011	6222	3201	11212	2.50
			27/19	49.9	8618	6603	3226	11844	2.67
			30/21	50.2	9269	6940	3245	12514	2.86
	0.423	15	24/17	51.1	7943	6207	3251	11194	2.44
			27/19	51.5	8545	6552	3283	11828	2.60
			30/21	51.9	9178	6921	3302	12480	2.78
	0.282	7	24/17	54.1	7795	6136	3356	11151	2.32
			27/19	54.6	8376	6473	3395	11771	2.47
			30/21	55.2	8984	6787	3429	12413	2.62

TEA : Entering air temperature (dry bulb/wet bulb).

TSE : Leaving water temperature.

Pt : Total cooling capacity.

Ps : Sensible cooling capacity.

Pabs : Compressor power input.

CR : Total heat rejection.

Heating Performance Data - HRW 036

Nominal Airflow 1580 m³/h

Entering Water Temp. (°C)	Water flow (l/s)	Water Pressure Drop (kPa)	Heating mode				
			TEA (°C)	Pc (W)	Pabs (W)	CA (W)	COP
13	0.564	25	16	10020	2620	7400	3.82
			20	9857	2792	7065	3.53
			27	9849	3208	6641	3.07
	0.423	15	16	9277	2506	6771	3.70
			20	9115	2703	6412	3.37
			27	8817	3063	5754	2.88
16	0.564	25	16	10245	2720	7525	3.77
			20	10144	2826	7318	3.59
			27	10045	3263	6782	3.08
	0.423	15	16	10027	2588	7439	3.87
			20	9860	2792	7068	3.53
			27	9562	3167	6395	3.02
	0.282	7	16	9518	2533	6985	3.76
			20	9348	2730	6618	3.42
			27	9113	3104	6009	2.94
20	0.564	25	16	11222	2767	8455	4.06
			20	11036	2979	8057	3.70
			27	10686	3362	7324	3.18
	0.423	15	16	10887	2728	8159	3.99
			20	10724	2940	7784	3.65
			27	10399	3322	7077	3.13
	0.282	7	16	10300	2663	7637	3.87
			20	10131	2867	7264	3.53
			27	9900	3253	6647	3.04
27	0.564	25	16	11535	2813	8722	4.10
			20	11259	3011	8248	3.74
			27	10967	3412	7555	3.21
	0.423	15	16	11161	2772	8389	4.03
			20	10976	2982	7994	3.68
			27	10672	3374	7298	3.16
	0.282	7	16	10520	2704	7816	3.89
			20	10345	2907	7438	3.56
			27	10076	3290	6786	3.06
30	0.564	25	16	11818	2827	8991	4.18
			20	11602	3038	8564	3.82
			27	11268	3437	7831	3.28
	0.423	15	16	11437	2787	8650	4.10
			20	11266	3004	8262	3.75
			27	10946	3395	7551	3.22
	0.282	7	16	10755	2716	8039	3.96
			20	10629	2930	7699	3.63
			27	10331	3313	7018	3.12
32	0.564	25	16	12057	2845	9212	4.24
			20	11840	3056	8784	3.87
			27	11468	3449	8019	3.33
	0.423	15	16	11671	2806	8865	4.16
			20	11497	3022	8475	3.80
			27	11140	3407	7733	3.27
	0.282	7	16	10988	2736	8252	4.02
			20	10819	2944	7875	3.67
			27	10549	3332	7217	3.17

TEA : Entering air temperature.
Pc : Heating capacity.

Pabs : Compressor power input.
CA : Total heat absorption.

Cooling Performance Data - HRW 042

Nominal Airflow 2040 m³/h

Entering Water Temp. (°C)	Water flow (l/s)	Water Pressure Drop (kPa)	Cooling mode						
			TEA (°C)	TSE (°C)	Pt (W)	Ps (W)	Pabs (W)	CR (W)	EER
13	0.72	33	24/17	17.8	12774	9106	1960	14734	6.52
			27/19	18.1	13616	9576	1977	15593	6.89
			30/21	18.4	14463	10003	1980	16443	7.30
	0.54	20	24/17	19.4	12687	9082	2020	14707	6.28
			27/19	19.8	13504	9546	2038	15542	6.63
			30/21	20.2	14360	9984	2051	16411	7.00
16	0.72	33	24/17	20.7	12494	8975	2121	14615	5.89
			27/19	21	13318	9489	2141	15459	6.22
			30/21	21.4	14167	9880	2152	16319	6.58
	0.54	20	24/17	22.3	12388	8937	2179	14567	5.69
			27/19	22.7	13203	9408	2204	15407	5.99
			30/21	23.1	14045	9848	2219	16264	6.33
	0.36	9	24/17	25.4	12204	8846	2294	14498	5.32
			27/19	25.9	12976	9292	2331	15307	5.57
			30/21	26.5	13791	9722	2364	16155	5.83
20	0.72	33	24/17	24.7	12131	8793	2348	14479	5.17
			27/19	25	12917	9298	2368	15285	5.45
			30/21	25.3	13784	9724	2389	16173	5.77
	0.54	20	24/17	26.2	12026	8758	2404	14430	5.00
			27/19	26.6	12709	9198	2440	15149	5.21
			30/21	27	13718	9671	2462	16180	5.57
	0.36	9	24/17	29.3	11826	8657	2529	14355	4.68
			27/19	29.8	12606	9122	2569	15175	4.91
			30/21	30.4	13367	9534	2607	15974	5.13
27	0.72	33	24/17	31.5	10899	8504	2707	13606	4.03
			27/19	31.8	11646	8959	2739	14385	4.25
			30/21	32.1	12455	9407	2776	15231	4.49
	0.54	20	24/17	33	10804	8477	2768	13572	3.90
			27/19	33.3	11521	8912	2809	14330	4.10
			30/21	33.7	12339	9383	2849	15188	4.33
	0.36	9	24/17	35.9	10620	8393	2891	13511	3.67
			27/19	36.4	12022	9212	2998	15020	4.01
			30/21	37	11350	8835	2949	14299	3.85
30	0.72	33	24/17	34.5	10564	8351	2898	13462	3.65
			27/19	34.7	11366	8849	2942	14308	3.86
			30/21	35	12039	9221	2975	15014	4.05
	0.54	20	24/17	35.9	10506	8309	2959	13465	3.55
			27/19	36.3	11217	8793	3011	14228	3.73
			30/21	36.7	11984	9185	3052	15036	3.93
	0.36	9	24/17	38.8	10323	8216	3087	13410	3.34
			27/19	39.4	11055	8674	3150	14205	3.51
			30/21	39.9	11706	9104	3210	14916	3.65

TEA : Entering air temperature (dry bulb/wet bulb).
TSE : Leaving water temperature.
Pt : Total cooling capacity.

Ps : Sensible cooling capacity.
Pabs : Compressor power input.
CR : Total heat rejection.

Cooling Performance Data - HRW 042 (continued)

Nominal Airflow 2040 m³/h

Entering Water Temp. (°C)	Water flow (l/s)	Water Pressure Drop (kPa)	Cooling mode						
			TEA (°C)	TSE (°C)	Pt (W)	Ps (W)	Pabs (W)	CR (W)	EER
32	0.72	33	24/17	36.4	10461	8318	3035	13496	3.45
			27/19	36.7	11153	8743	3076	14229	3.63
			30/21	37	11917	9194	3120	15037	3.82
	0.54	20	24/17	37.9	10314	8209	3094	13408	3.33
			27/19	38.2	11066	8682	3151	14217	3.51
			30/21	38.6	11791	9109	3197	14988	3.69
	0.36	9	24/17	40.8	10197	8158	3224	13421	3.16
			27/19	41.3	10853	8576	3287	14140	3.30
			30/21	41.8	11474	8927	3349	14823	3.43
38	0.72	33	24/17	42.6	10313	8042	3140	13453	3.28
			27/19	42.8	11050	8483	3185	14235	3.47
			30/21	43.1	11837	8941	3229	15066	3.67
	0.54	20	24/17	44	10213	8002	3206	13419	3.19
			27/19	44.4	10960	8475	3260	14220	3.36
			30/21	44.8	11702	8892	3305	15007	3.54
	0.36	9	24/17	47	10066	7935	3351	13417	3.00
			27/19	47.5	10704	8387	3414	14118	3.14
			30/21	48.1	11446	8781	3483	14929	3.29
40	0.72	33	24/17	44.8	10035	7949	3311	13346	3.03
			27/19	44.8	10843	8380	3335	14178	3.25
			30/21	45.1	11602	8877	3388	14990	3.42
	0.54	20	24/17	46	10000	7886	3359	13359	2.98
			27/19	46.4	10725	8351	3415	14140	3.14
			30/21	46.7	11458	8789	3470	14928	3.30
	0.36	9	24/17	48.9	9858	8263	3574	13432	2.76
			27/19	49.5	10478	8240	3554	14032	2.95
			30/21	50	11191	8700	3638	14829	3.08
45	0.72	33	24/17	49.4	9591	7725	3673	13264	2.61
			27/19	49.7	10256	8153	3734	13990	2.75
			30/21	49.9	10960	8535	3779	14739	2.90
	0.54	20	24/17	50.9	9444	7613	3736	13180	2.53
			27/19	51.2	10126	8111	3811	13937	2.66
			30/21	51.6	10837	8503	3871	14708	2.80
	0.36	9	24/17	53.7	9312	7561	3879	13191	2.40
			27/19	54.3	9897	8002	3963	13860	2.50
			30/21	54.8	10575	8435	4039	14614	2.62

TEA : Entering air temperature (dry bulb/wet bulb).

TSE : Leaving water temperature.

Pt : Total cooling capacity.

Ps : Sensible cooling capacity.

Pabs : Compressor power input.

CR : Total heat rejection.

Heating Performance Data - HRW 042

Nominal Airflow 2040 m³/h

Entering Water Temp. (°C)	Water flow (l/s)	Water Pressure Drop (kPa)	Heating mode				
			TEA (°C)	Pc (W)	Pabs (W)	CA (W)	COP
13	0.72	33	16	12578	2847	9731	4.42
			20	12222	3082	9140	3.97
			27	12390	3574	8816	3.47
	0.54	20	16	12023	2812	9211	4.28
			20	11840	3038	8802	3.90
			27	11505	3460	8045	3.33
16	0.72	33	16	13410	2953	10457	4.54
			20	13177	3188	9989	4.13
			27	12783	3625	9158	3.53
	0.54	20	16	13012	2913	10099	4.47
			20	12799	3146	9653	4.07
			27	12435	3581	8854	3.47
	0.36	9	16	12295	2836	9459	4.34
			20	12123	3067	9056	3.95
			27	11849	3506	8343	3.38
20	0.72	33	16	14686	3023	11663	4.86
			20	14422	3267	11155	4.41
			27	13974	3720	10254	3.76
	0.54	20	16	14206	2973	11233	4.78
			20	13996	3222	10774	4.34
			27	13615	3680	9935	3.70
	0.36	9	16	14056	2897	11159	4.85
			20	13263	3143	10120	4.22
			27	12910	3578	9332	3.61
27	0.72	33	16	16231	3140	13091	5.17
			20	15943	3396	12547	4.69
			27	15456	3871	11585	3.99
	0.54	20	16	15695	3093	12602	5.07
			20	15435	3346	12089	4.61
			27	14997	3817	11180	3.93
	0.36	9	16	14769	3010	11759	4.91
			20	14590	3266	11324	4.47
			27	14197	3948	10249	3.60
30	0.72	33	16	16408	3418	12990	4.80
			20	16120	3684	12436	4.38
			27	15612	4172	11440	3.74
	0.54	20	16	15869	3378	12491	4.70
			20	15608	3641	11967	4.29
			27	15119	4117	11002	3.67
	0.36	9	16	14887	3298	11589	4.51
			20	14642	3549	11093	4.13
			27	14270	4025	10245	3.55
32	0.72	33	16	17173	3520	13653	4.88
			20	16884	3798	13086	4.45
			27	16325	4290	12035	3.81
	0.54	20	16	16634	3487	13147	4.77
			20	16336	3754	12582	4.35
			27	15823	4242	11581	3.73
	0.36	9	16	15559	3404	12155	4.57
			20	15322	3666	11656	4.18
			27	14904	4145	10759	3.60

TEA : Entering air temperature.
Pc : Heating capacity.

Pabs : Compressor power input.
CA : Total heat absorption.

Cooling Performance Data - HRW 048

Nominal Airflow 2750 m³/h

Entering Water Temp. (°C)	Water flow (l/s)	Water Pressure Drop (kPa)	Cooling mode						
			TEA (°C)	TSE (°C)	Pt (W)	Ps (W)	Pabs (W)	CR (W)	EER
13	0.784	34	24/17	17.9	13720	10326	2059	16789	6.66
			27/19	18.2	14622	10849	2056	17688	7.11
			30/21	18.5	15566	11318	2052	18628	7.59
	0.588	20	24/17	19.5	13630	10261	2108	16748	6.47
			27/19	19.9	14476	10788	2110	17596	6.86
			30/21	20.3	15369	11247	2112	18491	7.28
16	0.784	34	24/17	20.8	13459	10175	2216	16685	6.07
			27/19	21.1	14340	10712	2216	17566	6.47
			30/21	21.4	15262	11204	2211	18483	6.90
	0.588	20	24/17	22.4	13382	10143	2265	16657	5.91
			27/19	22.8	14237	10663	2273	17520	6.26
			30/21	23.2	15153	11129	2273	18436	6.67
	0.392	10	24/17	25.6	13200	10049	2372	16582	5.56
			27/19	26.1	14023	10554	2390	17423	5.87
			30/21	26.7	14844	11014	2404	18258	6.17
20	0.784	34	24/17	24.8	13108	9998	2434	16552	5.39
			27/19	25.1	13953	10505	2439	17402	5.72
			30/21	25.4	14861	11025	2445	18316	6.08
	0.588	20	24/17	26.4	13020	9935	2487	16517	5.24
			27/19	26.4	13861	10449	2498	17369	5.55
			30/21	27.1	14643	10874	2509	18162	5.84
	0.392	10	24/17	29.5	12841	9845	2602	16453	4.94
			27/19	30.2	13797	10371	2632	17439	5.24
			30/21	30.6	14428	10824	2645	18083	5.45
27	0.784	34	24/17	31.7	12465	9674	2867	16342	4.35
			27/19	32	13274	10178	2881	17165	4.61
			30/21	32.3	14128	10667	2893	18031	4.88
	0.588	20	24/17	33.3	12392	9623	2928	16330	4.23
			27/19	33.7	13173	10152	2949	17132	4.47
			30/21	34	14033	10619	2962	18005	4.74
	0.392	10	24/17	36.4	12212	9532	3046	16268	4.01
			27/19	36.9	12980	10061	3084	17074	4.21
			30/21	37.4	13797	10506	3109	17916	4.44
30	0.784	34	24/17	34.7	12193	9507	3073	16276	3.97
			27/19	34.9	12965	10051	3088	17063	4.20
			30/21	35.2	13794	10504	3103	17907	4.45
	0.588	20	24/17	36.2	12099	9490	3130	16239	3.87
			27/19	36.6	12872	9973	3155	17037	4.08
			30/21	36.9	13697	10424	3172	17879	4.32
	0.392	10	24/17	39.3	11937	9374	3256	16203	3.67
			27/19	39.8	12673	9889	3293	16976	3.85
			30/21	40.4	13473	10388	3327	17810	4.05

TEA : Entering air temperature (dry bulb/wet bulb).
TSE : Leaving water temperature.
Pt : Total cooling capacity.

Ps : Sensible cooling capacity.
Pabs : Compressor power input.
CR : Total heat rejection.

Cooling Performance Data - HRW 048 (continued)

Nominal Airflow 2750 m³/h

Entering Water Temp. (°C)	Water flow (l/s)	Water Pressure Drop (kPa)	Cooling mode						
			TEA (°C)	TSE (°C)	Pt (W)	Ps (W)	Pabs (W)	CR (W)	EER
32	0.784	34	24/17	36.7	12002	9421	3215	16227	3.73
			27/19	36.9	12757	9950	3237	17004	3.94
			30/21	37.2	13595	10417	3251	17856	4.18
	0.588	20	24/17	38.2	11913	9396	3276	16199	3.64
			27/19	38.6	12664	9882	3299	16973	3.84
			30/21	38.9	13473	10388	3324	17807	4.05
	0.392	10	24/17	41.3	11750	9279	3401	16161	3.45
			27/19	41.8	12474	9794	3441	16925	3.63
			30/21	42.3	13260	10293	3479	17749	3.81
38	0.784	34	24/17	42.6	11399	9103	3664	16073	3.11
			27/19	42.9	12125	9642	3694	16829	3.28
			30/21	43.1	12916	10102	3717	17643	3.47
	0.588	20	24/17	44.2	11324	9048	3728	16062	3.04
			27/19	44.5	12053	9579	3769	16832	3.20
			30/21	44.8	12807	10004	3793	17610	3.38
	0.392	10	24/17	47.2	11144	8949	3862	16016	2.89
			27/19	47.7	11848	9487	3914	16772	3.03
			30/21	48.2	12596	9993	3955	17561	3.18
40	0.784	34	24/17	44.6	11196	8982	3831	16037	2.92
			27/19	44.9	11910	9533	3864	16784	3.08
			30/21	45.1	12694	9991	3890	17594	3.26
	0.588	20	24/17	46.1	11111	8920	3896	16017	2.85
			27/19	46.5	11818	9454	3930	16758	3.01
			30/21	46.8	12606	10000	3966	17582	3.18
	0.392	10	24/17	49.2	10950	8845	4028	15988	2.72
			27/19	49.7	11628	9378	4078	16716	2.85
			30/21	50.2	12379	9897	4127	17516	3.00
45	0.784	34	24/17	49.6	10672	8736	4258	15940	2.51
			27/19	49.8	11377	9236	4297	16684	2.65
			30/21	50.1	12123	9766	4329	17462	2.80
	0.588	20	24/17	51.1	10579	8667	4322	15911	2.45
			27/19	51.4	11279	9162	4371	16660	2.58
			30/21	51.7	12010	9681	4404	17424	2.73
	0.392	10	24/17	54.1	10429	8602	4459	15898	2.34
			27/19	54.6	11094	9110	4519	16623	2.45
			30/21	55.1	11808	9544	4573	17391	2.58

TEA : Entering air temperature (dry bulb/wet bulb).
TSE : Leaving water temperature.
Pt : Total cooling capacity.

Ps : Sensible cooling capacity.
Pabs : Compressor power input.
CR : Total heat rejection.

Heating Performance Data - HRW 048

Nominal Airflow 2750 m³/h

Entering Water Temp. (°C)	Water flow (l/s)	Water Pressure Drop (kPa)	Heating mode					
			TEA (°C)	TSE (°C)	Pc (W)	Pabs (W)	CA (W)	COP
13	0.784	34	16	9.9	13215	2850	9355	4.64
			20	10	13600	3164	9426	4.30
			27	10.1	13840	3739	9091	3.70
	0.588	20	16	9.1	12513	2776	8727	4.51
			20	9.3	12458	3038	8410	4.10
			27	9.5	12381	3543	7828	3.49
16	0.784	34	16	12.8	13718	2895	9813	4.74
			20	12.8	13680	3174	9496	4.31
			27	13.2	13686	3708	8968	3.69
	0.588	20	16	11.8	13408	2868	9530	4.68
			20	11.9	13319	3136	9173	4.25
			27	12.2	13188	3649	8529	3.61
	0.392	10	16	10.1	12841	2813	9018	4.56
			20	13.7	12787	3077	8700	4.16
			27	20.1	12705	3586	8109	3.54
20	0.784	34	16	16.4	15020	3022	10988	4.97
			20	16.6	14904	3309	10585	4.50
			27	16.8	14711	3856	9845	3.82
	0.588	20	16	15.4	14619	2980	10629	4.91
			20	15.5	14520	3265	10245	4.45
			27	15.8	14366	3808	9548	3.77
	0.392	10	16	13.5	13969	2921	10038	4.78
			20	13.7	13913	3202	9701	4.35
			27	14.1	13817	3739	9068	3.70
27	0.784	34	16	22.8	17424	3229	13185	5.40
			20	23	17291	3551	12730	4.87
			27	23.2	17015	4143	11862	4.11
	0.588	20	16	21.6	16976	3197	12769	5.31
			20	21.8	16826	3506	12310	4.80
			27	22.1	16594	4092	11492	4.06
	0.392	10	16	19.4	16129	3124	11995	5.16
			20	19.6	15983	3218	11755	4.97
			27	20.1	15839	3996	10833	3.96
30	0.784	34	16	25.5	18545	3322	14213	5.58
			20	25.6	18364	3651	13703	5.03
			27	26	18016	4254	12752	4.24
	0.588	20	16	24.2	18046	3285	13751	5.49
			20	24.4	17851	3601	13240	4.96
			27	24.8	17585	4208	12367	4.18
	0.392	10	16	21.8	17067	3203	12854	5.33
			20	22.1	16968	3522	12436	4.82
			27	22.6	16792	4118	11664	4.08
32	0.784	34	16	27.3	19329	3384	14935	5.71
			20	27.5	19075	3708	14357	5.14
			27	27.8	18750	4339	13401	4.32
	0.588	20	16	26	18770	3342	14418	5.62
			20	26.2	18549	3662	13877	5.07
			27	26.5	18271	4289	12972	4.26
	0.392	10	16	23.5	17729	3258	13461	5.44
			20	23.8	17613	3580	13023	4.92
			27	24.3	17388	4183	12195	4.16

TEA : Entering air temperature.
TSE : Leaving water temperature.
Pc : Heating capacity.

Pabs : Compressor power input.
CA : Total heat absorption.

Cooling Performance Data - HRW 060

Nominal Airflow 2840 m³/h

Entering Water Temp. (°C)	Water flow (l/s)	Water Pressure Drop (kPa)	Cooling mode						
			TEA (°C)	TSE (°C)	Pt (W)	Ps (W)	Pabs (W)	CR (W)	EER
13	0.93	40	24/17	17.4	14745	11132	2620	17365	5.63
			27/19	17.7	15883	11713	2616	18499	6.07
			30/21	18	17020	12232	2600	19620	6.55
	0.70	24	24/17	18.9	14725	11117	2670	17395	5.51
			27/19	19.3	15770	11673	2668	18438	5.91
			30/21	19.7	16796	12126	2656	19452	6.32
16	0.93	40	24/17	20.4	14508	11000	2782	17290	5.21
			27/19	20.7	15562	11569	2779	18341	5.60
			30/21	21	16645	12068	2766	19411	6.02
	0.70	24	24/17	21.8	14419	10939	2832	17251	5.09
			27/19	22.2	15464	11503	2836	18300	5.45
			30/21	22.6	16550	12005	2825	19375	5.86
	0.47	12	24/17	24.7	14238	10831	2937	17175	4.85
			27/19	25.2	15235	11385	2948	18183	5.17
			30/21	25.8	16202	11861	2951	19153	5.49
20	0.93	40	24/17	24.3	14098	10776	3016	17114	4.67
			27/19	24.6	15117	11343	3018	18135	5.01
			30/21	24.8	16207	11865	3007	19214	5.39
	0.70	24	24/17	25.7	13995	10705	3065	17060	4.57
			27/19	26.1	15002	11264	3074	18076	4.88
			30/21	26.5	16076	11776	3068	19144	5.24
	0.47	12	24/17	28.5	13826	10607	3173	16999	4.36
			27/19	29.1	14793	11161	3194	17987	4.63
			30/21	29.7	15829	11655	3200	19029	4.95
27	0.93	40	24/17	31.4	13864	10675	3767	17631	3.68
			27/19	31.6	14598	11116	3772	18370	3.87
			30/21	31.9	15740	11678	3765	19505	4.18
	0.70	24	24/17	32.8	13613	10541	3815	17428	3.57
			27/19	33.1	14597	11114	3832	18429	3.81
			30/21	33.5	15680	11708	3832	19512	4.09
	0.47	12	24/17	35.6	13432	10458	3934	17366	3.41
			27/19	36.1	14373	11010	3959	18332	3.63
			30/21	36.6	15452	11612	3972	19424	3.89
30	0.93	40	24/17	34.3	13370	10413	3976	17346	3.36
			27/19	34.6	14344	10988	3987	18331	3.60
			30/21	34.8	15296	11500	3984	19280	3.84
	0.70	24	24/17	35.7	13285	10351	4028	17313	3.30
			27/19	36	14244	10975	4045	18289	3.52
			30/21	36.4	15152	11456	4052	19204	3.74
	0.47	12	24/17	38.5	13164	10313	4140	17304	3.18
			27/19	39	14108	10876	4175	18283	3.38
			30/21	39.5	15050	11391	4190	19240	3.59

TEA : Entering air temperature (dry bulb/wet bulb).
TSE : Leaving water temperature.
Pt : Total cooling capacity.

Ps : Sensible cooling capacity.
Pabs : Compressor power input.
CR : Total heat rejection.

Cooling Performance Data - HRW 060 (continued)

Nominal Airflow 2840 m³/h

Entering Water Temp. (°C)	Water flow (l/s)	Water Pressure Drop (kPa)	Cooling mode						
			TEA (°C)	TSE (°C)	Pt (W)	Ps (W)	Pabs (W)	CR (W)	EER
32	0.93	40	24/17	36.3	13219	10353	4118	17337	3.21
			27/19	36.5	14182	10929	4138	18320	3.43
			30/21	36.8	15249	11535	4134	19383	3.69
	0.70	24	24/17	37.6	13194	10335	4175	17369	3.16
			27/19	38	14147	10903	4195	18342	3.37
			30/21	38.4	15137	11445	4203	19340	3.60
	0.47	12	24/17	40.4	13008	10250	4286	17294	3.03
			27/19	40.9	13924	10792	4318	18242	3.22
			30/21	41.5	14899	11351	4347	19246	3.43
38	0.93	40	24/17	42.1	12576	10111	4948	17524	2.54
			27/19	42.4	13488	10692	4967	18455	2.72
			30/21	42.7	14425	11173	4990	19415	2.89
	0.70	24	24/17	43.5	12542	10086	4982	17524	2.52
			27/19	43.8	13444	10660	5002	18446	2.69
			30/21	44.2	14428	11237	5027	19455	2.87
	0.47	12	24/17	46.2	12317	9967	5051	17368	2.44
			27/19	46.7	13300	10593	5091	18391	2.61
			30/21	47.3	14264	11080	5135	19399	2.78
40	0.93	40	24/17	44.1	12324	10017	5113	17437	2.41
			27/19	44.4	13231	10561	5136	18367	2.58
			30/21	44.7	14227	11118	5164	19391	2.76
	0.70	24	24/17	45.4	12182	9914	5129	17311	2.38
			27/19	45.8	13173	10518	5171	18344	2.55
			30/21	46.2	14170	11050	5200	19370	2.73
	0.47	12	24/17	48.1	12158	9896	5215	17373	2.33
			27/19	48.7	13041	10459	5258	18299	2.48
			30/21	49.2	13995	10950	5289	19284	2.65
45	0.93	40	24/17	49	11720	9667	5539	17259	2.12
			27/19	49.3	12589	10239	5572	18161	2.26
			30/21	49.6	13539	10819	5591	19130	2.42
	0.70	24	24/17	50.3	11681	9638	5555	17236	2.10
			27/19	50.7	12551	10211	5605	18156	2.24
			30/21	51.1	13483	10772	5626	19109	2.40
	0.47	12	24/17	52.9	11464	9526	5620	17084	2.04
			27/19	53.5	12408	10163	5672	18080	2.19
			30/21	54	13324	10654	5728	19052	2.33

TEA : Entering air temperature (dry bulb/wet bulb).

TSE : Leaving water temperature.

Pt : Total cooling capacity.

Ps : Sensible cooling capacity.

Pabs : Compressor power input.

CR : Total heat rejection.

Heating Performance Data - HRW 060

Nominal Airflow 2840 m³/h

Entering Water Temp. (°C)	Water flow (l/s)	Water Pressure Drop (kPa)	Heating mode				
			TEA (°C)	Pc (W)	Pabs (W)	CA (W)	COP
13	0.93	40	16	14453	3606	10847	4.01
			20	14341	3881	10460	3.70
			27	14075	4391	9684	3.21
	0.70	24	16	12693	3368	9325	3.77
			20	12427	3664	8763	3.39
			27	12176	4247	7929	2.87
16	0.93	40	16	15353	3693	11660	4.16
			20	15230	3980	11250	3.83
			27	15140	4529	10611	3.34
	0.70	24	16	12981	3391	9590	3.83
			20	12454	3730	8724	3.34
			27	12207	4308	7899	2.83
	0.47	12	16	11867	3332	8535	3.56
			20	11642	3570	8072	3.26
			27	11268	4019	7249	2.80
20	0.93	40	16	16396	3818	12578	4.29
			20	16147	4160	11987	3.88
			27	15741	4766	10975	3.30
	0.70	24	16	13882	3630	10252	3.82
			20	13618	3882	9736	3.51
			27	13182	4358	8824	3.02
	0.47	12	16	13256	3566	9690	3.72
			20	13011	3815	9196	3.41
			27	12606	4279	8327	2.95
27	0.93	40	16	17276	4082	13194	4.23
			20	16955	4366	12589	3.88
			27	16443	4896	11547	3.36
	0.70	24	16	16782	4032	12750	4.16
			20	16519	4324	12195	3.82
			27	15995	4841	11154	3.30
	0.47	12	16	16001	3964	12037	4.04
			20	15736	4243	11493	3.71
			27	15284	4754	10530	3.21
30	0.93	40	16	18522	4334	14188	4.27
			20	18198	4634	13564	3.93
			27	17627	5182	12445	3.40
	0.70	24	16	18007	4291	13716	4.20
			20	17709	4588	13121	3.86
			27	17176	5133	12043	3.35
	0.47	12	16	17106	4215	12891	4.06
			20	16859	4508	12351	3.74
			27	16411	5045	11366	3.25
32	0.93	40	16	19361	4398	14963	4.40
			20	19010	4702	14308	4.04
			27	18480	5276	13204	3.50
	0.70	24	16	18844	4362	14482	4.32
			20	18522	4662	13860	3.97
			27	17981	5222	12759	3.44
	0.47	12	16	17849	4276	13573	4.17
			20	17608	4581	13027	3.84
			27	17159	5133	12026	3.34

TEA : Entering air temperature.
Pc : Heating capacity.

Pabs : Compressor power input.
CA : Total heat absorption.

Cooling Performance Data - HRW 072

Nominal Airflow 3570 m³/h

Entering Water Temp. (°C)	Water flow (l/s)	Water Pressure Drop (kPa)	Cooling mode						
			TEA (°C)	TSE (°C)	Pt (W)	Ps (W)	Pabs (W)	CR (W)	EER
13	1.09	61	24/17	17.8	18234	13660	3169	21403	5.75
			27/19	18.3	19899	14725	3249	23148	6.12
			30/21	18.7	21708	15690	3310	25018	6.56
	0.82	34	24/17	19.4	18089	13654	3293	21382	5.49
			27/19	20.0	19782	14639	3391	23173	5.83
			30/21	20.5	21246	15478	3457	24703	6.15
16	1.09	61	24/17	20.8	17948	13548	3445	21393	5.21
			27/19	21.2	19470	14521	3531	23001	5.51
			30/21	21.7	21116	15512	3598	24714	5.87
	0.82	34	24/17	22.4	17509	13318	3565	21074	4.91
			27/19	22.9	19203	14440	3670	22873	5.23
			30/21	23.4	20536	15083	3729	24265	5.51
	0.54	15	24/17	25.6	17236	13218	3836	21072	4.49
			27/19	26.3	18691	14174	3958	22649	4.72
			30/21	26.9	20041	14980	4051	24092	4.95
20	1.09	61	24/17	24.9	17433	13370	3853	21286	4.52
			27/19	25.2	18801	14258	3917	22718	4.80
			30/21	25.5	20355	15080	3983	24338	5.11
	0.82	34	24/17	26.3	16888	13061	3937	20825	4.29
			27/19	26.8	18535	14055	4066	22601	4.56
			30/21	27.3	20175	15082	4163	24338	4.85
	0.54	15	24/17	29.3	16474	12853	4183	20657	3.94
			27/19	30.2	18077	13959	4347	22424	4.16
			30/21	30.7	19532	14735	4448	23980	4.39
27	1.09	61	24/17	31.6	16336	12745	4521	20857	3.61
			27/19	32.0	17683	13653	4652	22335	3.80
			30/21	32.3	19063	14520	4729	23792	4.03
	0.82	34	24/17	33.1	15907	12647	4627	20534	3.44
			27/19	33.6	17495	13638	4789	22284	3.65
			30/21	34.0	18492	14439	4857	23349	3.81
	0.54	15	24/17	36.3	16057	12645	4962	21019	3.24
			27/19	36.9	17233	13592	5087	22320	3.39
			30/21	37.5	18388	14373	5203	23591	3.53
30	1.09	61	24/17	34.6	15850	12602	4852	20702	3.27
			27/19	35.0	17174	13536	4970	22144	3.46
			30/21	35.3	18545	14473	5058	23603	3.67
	0.82	34	24/17	36.2	15994	12719	5026	21020	3.18
			27/19	36.6	16851	13342	5121	21972	3.29
			30/21	37.0	18298	14317	5226	23524	3.50
	0.54	15	24/17	39.2	15669	12471	5282	20951	2.97
			27/19	39.7	16644	13215	5397	22041	3.08
			30/21	40.4	17799	14010	5548	23347	3.21

TEA : Entering air temperature (dry bulb/wet bulb).
TSE : Leaving water temperature.
Pt : Total cooling capacity.

Ps : Sensible cooling capacity.
Pabs : Compressor power input.
CR : Total heat rejection.

Cooling Performance Data - HRW 072 (continued)

Nominal Airflow 3570 m³/h

Entering Water Temp. (°C)	Water flow (l/s)	Water Pressure Drop (kPa)	Cooling mode						
			TEA (°C)	TSE (°C)	Pt (W)	Ps (W)	Pabs (W)	CR (W)	EER
32	1.09	61	24/17	36.7	15929	12667	5111	21040	3.12
			27/19	36.9	16716	13256	5181	21897	3.23
			30/21	37.2	18217	14267	5306	23523	3.43
	0.82	34	24/17	38.2	15649	12458	5248	20897	2.98
			27/19	38.5	16460	13228	5318	21778	3.10
			30/21	38.9	17876	14057	5444	23320	3.28
	0.54	15	24/17	41.1	15257	12319	5498	20755	2.78
			27/19	41.7	16228	13207	5620	21848	2.89
			30/21	42.3	17417	14067	5774	23191	3.02
38	1.09	61	24/17	42.4	14522	11952	5714	20236	2.54
			27/19	42.7	15645	12833	5846	21491	2.68
			30/21	43.1	16963	13775	6009	22972	2.82
	0.82	34	24/17	44.1	14805	12141	5934	20739	2.49
			27/19	44.2	15552	12901	5987	21539	2.60
			30/21	44.7	16705	13756	6154	22859	2.71
	0.54	15	24/17	46.9	14316	11937	6165	20481	2.32
			27/19	47.6	15309	12876	6347	21656	2.41
			30/21	48.2	16635	13717	6509	23144	2.56
40	1.09	61	24/17	44.5	14615	12016	6029	20644	2.42
			27/19	44.7	15257	12839	6087	21344	2.51
			30/21	45.1	16523	13783	6252	22775	2.64
	0.82	34	24/17	46.0	14469	12040	6140	20609	2.36
			27/19	46.3	15318	12882	6276	21594	2.44
			30/21	46.7	16415	13717	6419	22834	2.56
	0.54	15	24/17	48.7	13729	11665	6344	20073	2.16
			27/19	49.2	14731	12507	6490	21221	2.27
			30/21	50.0	15932	13422	6715	22647	2.37
45	1.09	61	24/17	49.4	13841	11743	6632	20473	2.09
			27/19	49.6	14615	12555	6707	21322	2.18
			30/21	50.0	15842	13372	6880	22722	2.30
	0.82	34	24/17	50.9	13638	11612	6746	20384	2.02
			27/19	51.1	14274	12455	6842	21116	2.09
			30/21	51.6	15433	13376	7016	22449	2.20
	0.54	15	24/17	53.7	13294	11609	6991	20285	1.90
			27/19	54.1	14085	12338	7118	21203	1.98
			30/21	54.7	14988	13109	7288	22276	2.06

TEA : Entering air temperature (dry bulb/wet bulb).
TSE : Leaving water temperature.
Pt : Total cooling capacity.

Ps : Sensible cooling capacity.
Pabs : Compressor power input.
CR : Total heat rejection.

Heating Performance Data - HRW 072

Nominal Airflow 3570 m³/h

Entering Water Temp. (°C)	Water flow (l/s)	Water Pressure Drop (kPa)	Heating mode				
			TEA (°C)	Pc (W)	Pabs (W)	CA (W)	COP
13	1.09	61	16	19244	5241	14004	3.67
			20	19095	5641	13455	3.39
			27	18741	6382	12359	2.94
	0.82	34	16	16901	4895	12006	3.45
			20	16547	5325	11222	3.11
			27	16213	6172	10040	2.63
16	1.09	61	16	20443	5367	15075	3.81
			20	20279	5784	14495	3.51
			27	20159	6582	13577	3.06
	0.82	34	16	17284	4928	12356	3.51
			20	16583	5421	11162	3.06
			27	16254	6261	9993	2.60
	0.54	15	16	15801	4843	10958	3.26
			20	15502	5189	10313	2.99
			27	15004	5841	9162	2.57
20	1.09	61	16	21832	5549	16283	3.93
			20	21500	6046	15454	3.56
			27	20959	6927	14033	3.03
	0.82	34	16	18484	5276	13208	3.50
			20	18133	5642	12491	3.21
			27	17552	6334	11218	2.77
	0.54	15	16	17651	5183	12468	3.41
			20	17324	5545	11780	3.12
			27	16785	6219	10566	2.70
27	1.09	61	16	23003	5933	17071	3.88
			20	22576	6345	16230	3.56
			27	21894	7116	14778	3.08
	0.82	34	16	22346	5860	16486	3.81
			20	21995	6284	15711	3.50
			27	21298	7036	14262	3.03
	0.54	15	16	21306	5761	15544	3.70
			20	20953	6167	14786	3.40
			27	20351	6909	13442	2.95
30	1.09	61	16	24662	6299	18363	3.92
			20	24231	6735	17496	3.60
			27	23471	7531	15939	3.12
	0.82	34	16	23977	6236	17740	3.84
			20	23580	6668	16912	3.54
			27	22870	7460	15410	3.07
	0.54	15	16	22777	6126	16651	3.72
			20	22448	6552	15896	3.43
			27	21852	7332	14519	2.98
32	1.09	61	16	25779	6392	19388	4.03
			20	25312	6834	18478	3.70
			27	24606	7668	16938	3.21
	0.82	34	16	25091	6340	18752	3.96
			20	24662	6776	17887	3.64
			27	23942	7589	16353	3.15
	0.54	15	16	23766	6215	17552	3.82
			20	23445	6658	16787	3.52
			27	22847	7460	15387	3.06

TEA : Entering air temperature.
Pc : Heating capacity.

Pabs : Compressor power input.
CA : Total heat absorption.

Cooling Performance Data - HRW 096

Nominal Airflow 4700 m³/h

Entering Water Temp. (°C)	Water flow (l/s)	Water Pressure Drop (kPa)	Cooling mode						
			TEA (°C)	TSE (°C)	Pt (W)	Ps (W)	Pabs (W)	CR (W)	EER
13	1.01	33	24/17	19.5	23156	17894	3704	26860	6.25
			27/19	20.1	25130	19390	3722	28852	6.75
			30/21	20.6	27232	20333	3713	30945	7.33
16	1.35	55	24/17	20.8	22405	17629	3885	26290	5.77
			27/19	21.2	24530	19108	3899	28429	6.29
			30/21	21.7	26949	20512	3888	30837	6.93
	1.01	33	24/17	22.4	22250	17506	3974	26224	5.60
			27/19	22.9	24304	18930	4008	28312	6.06
			30/21	23.6	26621	20260	4022	30643	6.62
	0.68	14	24/17	25.5	21863	17368	4165	26028	5.25
			27/19	26.6	24304	18931	4261	28565	5.70
			30/21	27.2	26064	19858	4281	30345	6.09
20	1.35	55	24/17	24.7	21644	17208	4266	25910	5.07
			27/19	25.1	23635	18652	4298	27933	5.50
			30/21	25.6	26075	19865	4308	30383	6.05
	1.01	33	24/17	26.7	22821	17795	4399	27220	5.19
			27/19	26.8	23368	18480	4404	27772	5.31
			30/21	27.4	25734	20064	4439	30173	5.80
	0.68	14	24/17	29.9	22370	17604	4619	26989	4.84
			27/19	30.5	23650	18665	4677	28327	5.06
			30/21	31.0	25123	19680	4705	29828	5.34
27	1.35	55	24/17	31.9	21388	17218	5019	26407	4.26
			27/19	32.0	22391	18222	5052	27443	4.43
			30/21	32.5	24435	19455	5100	29535	4.79
	1.01	33	24/17	33.2	20569	16838	5091	25660	4.04
			27/19	33.9	22743	18457	5186	27929	4.39
			30/21	34.2	24081	19434	5222	29303	4.61
	0.68	14	24/17	36.7	21024	17151	5360	26384	3.92
			27/19	37.2	22500	18299	5432	27932	4.14
			30/21	37.7	23554	19108	5488	29042	4.29
30	1.35	55	24/17	34.6	19969	16604	5302	25271	3.77
			27/19	35.0	21743	17986	5380	27123	4.04
			30/21	35.4	23660	19373	5444	29104	4.35
	1.01	33	24/17	36.2	20255	16801	5424	25679	3.73
			27/19	36.6	21562	17869	5493	27055	3.93
			30/21	37.1	23365	19186	5576	28941	4.19
	0.68	14	24/17	39.6	20264	16811	5687	25951	3.56
			27/19	40.2	21800	18030	5787	27587	3.77
			30/21	40.5	22852	19063	5834	28686	3.92

TEA : Entering air temperature (dry bulb/wet bulb).
TSE : Leaving water temperature.
Pt : Total cooling capacity.

Ps : Sensible cooling capacity.
Pabs : Compressor power input.
CR : Total heat rejection.

Cooling Performance Data - HRW 096 (continued)

Nominal Airflow 4700 m³/h

Entering Water Temp. (°C)	Water flow (l/s)	Water Pressure Drop (kPa)	Cooling mode						
			TEA (°C)	TSE (°C)	Pt (W)	Ps (W)	Pabs (W)	CR (W)	EER
32	1.35	55	24/17	36.6	20142	16726	5560	25702	3.62
			27/19	36.9	21313	17888	5617	26930	3.79
			30/21	37.3	23115	19030	5691	28806	4.06
	1.01	33	24/17	38.1	19846	16526	5629	25475	3.53
			27/19	38.7	21691	17958	5753	27444	3.77
			30/21	39	22716	18975	5804	28520	3.91
	0.68	14	24/17	41.3	19683	16588	5892	25575	3.34
			27/19	42	21263	17863	6007	27270	3.54
			30/21	42.5	22427	18799	6093	28520	3.68
38	1.35	55	24/17	42.6	19231	16287	6293	25524	3.06
			27/19	42.9	20431	17497	6368	26799	3.21
			30/21	43	21200	18398	6382	27582	3.32
	1.01	33	24/17	43.7	18127	15854	6246	24373	2.90
			27/19	44.6	20743	17533	6503	27246	3.19
			30/21	44.9	21695	18719	6570	28265	3.30
	0.68	14	24/17	47.2	18756	16134	6601	25357	2.84
			27/19	47.4	19615	17136	6657	26272	2.95
			30/21	48.2	21454	18570	6842	28296	3.14
40	1.35	55	24/17	44.5	18938	16256	6506	25444	2.91
			27/19	44.9	20399	17483	6632	27031	3.08
			30/21	45.1	21342	18495	6692	28034	3.19
	1.01	33	24/17	45.7	17806	15643	6491	24297	2.74
			27/19	46.6	20134	17483	6758	26892	2.98
			30/21	46.6	20703	18101	6783	27486	3.05
	0.68	14	24/17	49.3	18810	16018	6882	25692	2.73
			27/19	49.4	19405	17009	6920	26325	2.80
			30/21	50.3	20952	18279	7124	28076	2.94
45	1.35	55	24/17	49.6	18013	15952	7194	25207	2.50
			27/19	49.6	18748	16889	7224	25972	2.60
			30/21	49.9	20071	18040	7318	27389	2.74
	1.01	33	24/17	51.1	17843	15835	7293	25136	2.45
			27/19	51.4	19222	17056	7398	26620	2.60
			30/21	51.5	19767	17850	7450	27217	2.65
	0.68	14	24/17	54	17533	15627	7481	25014	2.34
			27/19	54.1	18365	16642	7544	25909	2.43
			30/21	54.8	19742	17840	7745	27487	2.55

TEA : Entering air temperature (dry bulb/wet bulb).

TSE : Leaving water temperature.

Pt : Total cooling capacity.

Ps : Sensible cooling capacity.

Pabs : Compressor power input.

CR : Total heat rejection.

Heating Performance Data - HRW 096

Nominal Airflow 4700 m³/h

Entering Water Temp. (°C)	Water flow (l/s)	Water Pressure Drop (kPa)	Heating mode				
			TEA (°C)	Pc (W)	Pabs (W)	CA (W)	COP
13	1.01	33	16	21859	6000	15859	3.64
			20	21694	6415	15279	3.38
			27	21418	7205	14213	2.97
16	1.35	55	16	24340	6277	18063	3.88
			20	24134	6710	17424	3.60
			27	23790	7557	16233	3.15
	1.01	33	16	23613	6200	17413	3.81
			20	23430	6628	16802	3.54
			27	23105	7443	15662	3.10
	0.68	14	16	22332	6048	16284	3.69
			20	22208	6469	15739	3.43
			27	21977	7272	14705	3.02
20	1.35	55	16	26859	6529	20330	4.11
			20	26637	7007	19630	3.80
			27	26220	7890	18330	3.32
	1.01	33	16	26018	6430	19588	4.05
			20	25822	6904	18918	3.74
			27	25454	7778	17676	3.27
	0.68	14	16	24540	6285	18255	3.90
			20	24454	6750	17704	3.62
			27	24147	7583	16564	3.18
27	1.35	55	16	31548	6937	24611	4.55
			20	31271	7479	23792	4.18
			27	30795	8477	22318	3.63
	1.01	33	16	30541	6860	23681	4.45
			20	30324	7394	22930	4.10
			27	29811	8352	21459	3.57
	0.68	14	16	28874	6719	22155	4.30
			20	28519	7210	21309	3.96
			27	28194	8150	20044	3.46
30	1.35	55	16	33670	7100	26570	4.74
			20	33349	7656	25693	4.36
			27	32838	8709	24129	3.77
	1.01	33	16	32563	7006	25557	4.65
			20	32287	7555	24732	4.27
			27	31818	8596	23222	3.70
	0.68	14	16	30761	6889	23872	4.47
			20	30596	7424	23172	4.12
			27	29888	8353	21535	3.58
32	1.35	55	16	35148	7201	27947	4.88
			20	34817	7766	27051	4.48
			27	34192	8837	25355	3.87
	1.01	33	16	33944	7122	26822	4.77
			20	33666	7678	25988	4.38
			27	33121	8734	24387	3.79
	0.68	14	16	31602	6932	24670	4.56
			20	31825	7534	24291	4.22
			27	31296	8538	22758	3.67

TEA : Entering air temperature.
Pc : Heating capacity.

Pabs : Compressor power input.
CA : Total heat absorption.

Cooling Performance Data - HRW 120

Nominal Airflow 5600 m³/h

Entering Water Temp. (°C)	Water flow (l/s)	Water Pressure Drop (kPa)	Cooling mode						
			TEA (°C)	TSE (°C)	Pt (W)	Ps (W)	Pabs (W)	CR (W)	EER
13	1.78	114	24/17	18.1	32215	24780	4797	37012	6.72
			27/19	18.3	34821	26482	4800	39621	7.25
			30/21	18.7	36647	27735	4762	41409	7.70
16	1.78	114	24/17	21.0	31904	24538	5168	37072	6.17
			27/19	21.3	34076	26156	5176	39252	6.58
			30/21	21.6	35923	27464	5159	41082	6.96
	1.34	62	24/17	22.7	31562	24494	5321	36883	5.93
			27/19	23.0	33375	25866	5335	38710	6.26
			30/21	23.6	36111	27352	5351	41462	6.75
20	1.78	114	24/17	25.0	30869	24180	5684	36553	5.43
			27/19	25.2	32648	25559	5704	38352	5.72
			30/21	25.6	34971	27110	5723	40694	6.11
	1.34	62	24/17	26.6	30418	24059	5843	36261	5.21
			27/19	27.0	32454	25425	5886	38340	5.51
			30/21	27.2	34135	26613	5891	40026	5.79
	0.89	26	24/17	29.6	28856	23206	6123	34979	4.71
			27/19	30.1	30997	24806	6208	37205	4.99
			30/21	30.8	32951	26195	6276	39227	5.25
27	1.78	114	24/17	31.9	29095	23308	6672	35767	4.36
			27/19	32.1	30735	24887	6707	37442	4.58
			30/21	32.2	32480	26197	6735	39215	4.82
	1.34	62	24/17	33.4	28791	23357	6818	35609	4.22
			27/19	33.8	30676	24853	6895	37571	4.45
			30/21	34.1	32442	26179	6947	39389	4.67
	0.89	26	24/17	36.5	27957	23060	7128	35085	3.92
			27/19	37.1	29878	24617	7243	37121	4.13
			30/21	37.8	32278	26371	7370	39648	4.38
30	1.78	114	24/17	34.8	28213	22985	7089	35302	3.98
			27/19	35.0	29951	24413	7163	37114	4.18
			30/21	35.3	31887	25863	7245	39132	4.40
	1.34	62	24/17	36.4	28231	23000	7272	35503	3.88
			27/19	36.8	29985	24438	7360	37345	4.07
			30/21	37.1	31368	26087	7424	38792	4.23
	0.89	26	24/17	39.5	27285	22631	7584	34869	3.60
			27/19	39.9	28728	24155	7676	36404	3.74
			30/21	40.6	31073	25918	7845	38918	3.96

TEA : Entering air temperature (dry bulb/wet bulb).

TSE : Leaving water temperature.

Pt : Total cooling capacity.

Ps : Sensible cooling capacity.

Pabs : Compressor power input.

CR : Total heat rejection.

Cooling Performance Data - HRW 120 (continued)

Nominal Airflow 5600 m³/h

Entering Water Temp. (°C)	Water flow (l/s)	Water Pressure Drop (kPa)	Cooling mode						
			TEA (°C)	TSE (°C)	Pt (W)	Ps (W)	Pabs (W)	CR (W)	EER
32	1.78	114	24/17	36.5	26867	22585	7304	34171	3.68
			27/19	37	29402	24577	7472	36874	3.93
			30/21	37.3	31454	26142	7564	39018	4.16
	1.34	62	24/17	38.3	27394	22701	7557	34951	3.62
			27/19	38.7	29268	24494	7665	36933	3.82
			30/21	39.1	31113	25940	7763	38876	4.01
	0.89	26	24/17	41.4	26606	22425	7870	34476	3.38
			27/19	41.9	28373	24180	7993	36366	3.55
			30/21	42.5	30317	25472	8143	38460	3.72
38	1.78	114	24/17	42.6	26299	22465	8333	34632	3.16
			27/19	42.7	27192	23676	8383	35575	3.24
			30/21	43.1	29500	25498	8553	38053	3.45
	1.34	62	24/17	44.1	25441	22124	8463	33904	3.01
			27/19	44.5	27819	23848	8642	36461	3.22
			30/21	44.9	29422	25458	8767	38189	3.36
	0.89	26	24/17	47.2	25074	21889	8801	33875	2.85
			27/19	47.7	26766	23431	8978	35744	2.98
			30/21	48.3	28600	24683	9146	37746	3.13
40	1.78	114	24/17	44.7	25952	22245	8680	34632	2.99
			27/19	44.7	26773	23645	8705	35478	3.08
			30/21	45.2	29268	25370	8922	38190	3.28
	1.34	62	24/17	46.1	25427	22125	8806	34233	2.89
			27/19	46.5	27255	23736	8968	36223	3.04
			30/21	46.8	28830	25118	9104	37934	3.17
	0.89	26	24/17	49.1	24839	21745	9132	33971	2.72
			27/19	49.4	25980	23364	9262	35242	2.81
			30/21	49.9	27108	24919	9424	36532	2.88
45	1.78	114	24/17	49.5	24270	21587	9479	33749	2.56
			27/19	49.8	25973	23372	9641	35614	2.69
			30/21	50	27413	24731	9774	37187	2.80
	1.34	62	24/17	51	24320	21626	9658	33978	2.52
			27/19	51.3	25583	23126	9808	35391	2.61
			30/21	51.7	27399	24727	9975	37374	2.75
	0.89	26	24/17	54	23711	21426	9966	33677	2.38
			27/19	54.4	25343	22989	10170	35513	2.49
			30/21	54.9	26443	24519	10348	36791	2.56

TEA : Entering air temperature (dry bulb/wet bulb).
TSE : Leaving water temperature.
Pt : Total cooling capacity.

Ps : Sensible cooling capacity.
Pabs : Compressor power input.
CR : Total heat rejection.

Heating Performance Data - HRW 120

Nominal Airflow 5600 m³/h

Entering Water Temp. (°C)	Water flow (l/s)	Water Pressure Drop (kPa)	Heating mode				
			TEA (°C)	Pc (W)	Pabs (W)	CA (W)	COP
13	1.78	114	16	32381	7538	24843	4.30
			20	32050	8111	23939	3.95
			27	31492	9195	22297	3.42
16	1.78	114	16	34962	7852	27110	4.45
			20	34584	8444	26140	4.10
			27	33940	9568	24372	3.55
	1.34	62	16	33999	7745	26254	4.39
			20	33618	8329	25289	4.04
			27	33056	9440	23616	3.50
20	1.78	114	16	38486	8237	30249	4.67
			20	38109	8894	29215	4.28
			27	37407	10103	27304	3.70
	1.34	62	16	37323	8101	29222	4.61
			20	37009	8752	28257	4.23
			27	36349	9946	26403	3.65
	0.89	26	16	35236	7897	27339	4.46
			20	34939	8495	26444	4.11
			27	34431	9633	24798	3.57
27	1.78	114	16	44882	8828	36054	5.08
			20	44438	9573	34865	4.64
			27	43557	10904	32653	3.99
	1.34	62	16	43407	8684	34723	5.00
			20	43047	9420	33627	4.57
			27	42338	10736	31602	3.94
	0.89	26	16	40863	8454	32409	4.83
			20	40598	9171	31427	4.43
			27	40013	10457	29556	3.83
30	1.78	114	16	47764	9045	38719	5.28
			20	47199	9812	37387	4.81
			27	46256	11215	35041	4.12
	1.34	62	16	46157	8925	37232	5.17
			20	45747	9678	36069	4.73
			27	44882	11025	33857	4.07
	0.89	26	16	43460	8727	34733	4.98
			20	43067	9420	33647	4.57
			27	42393	10738	31655	3.95
32	1.78	114	16	49666	9184	40482	5.41
			20	49130	9958	39172	4.93
			27	48038	11386	36652	4.22
	1.34	62	16	48045	9079	38966	5.29
			20	47573	9844	37729	4.83
			27	46667	11250	35417	4.15
	0.89	26	16	45164	8866	36298	5.09
			20	44794	9611	35183	4.66
			27	44002	10945	33057	4.02

TEA : Entering air temperature.
Pc : Heating capacity.

Pabs : Compressor power input.
CA : Total heat absorption.

Dimensions (mm) - HRW 007, 009 & 012

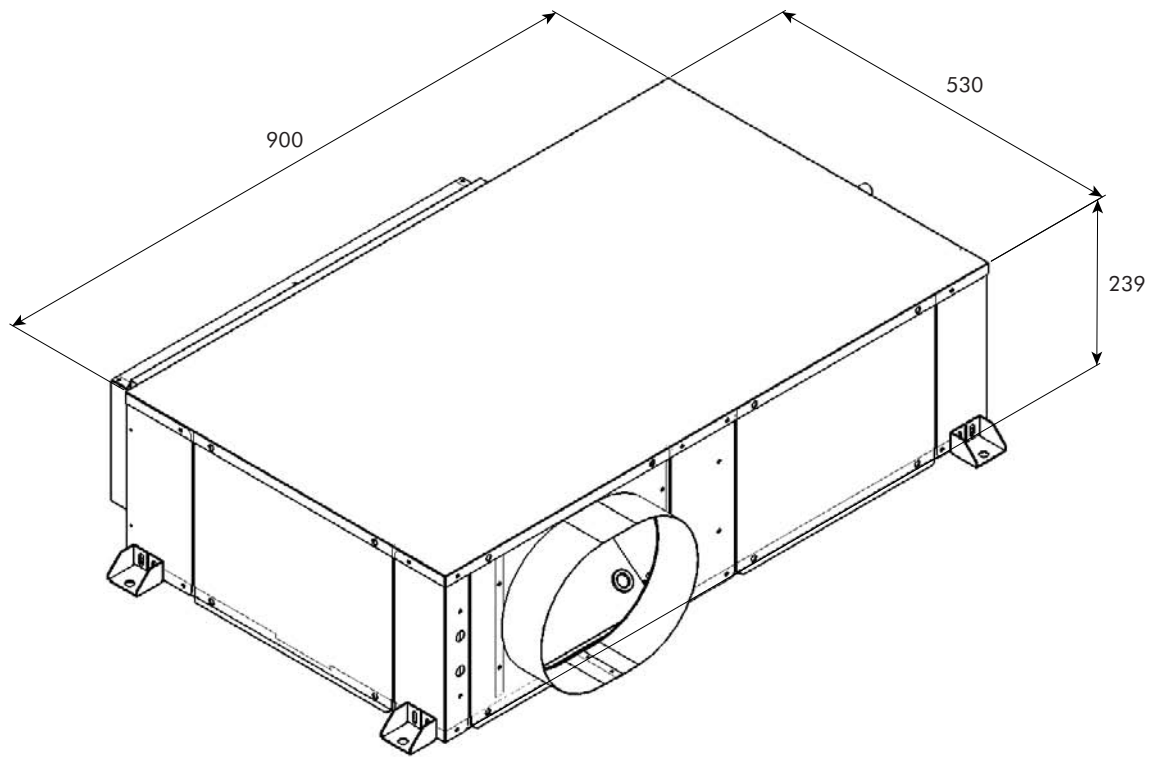

Air duct connection - Discharge side

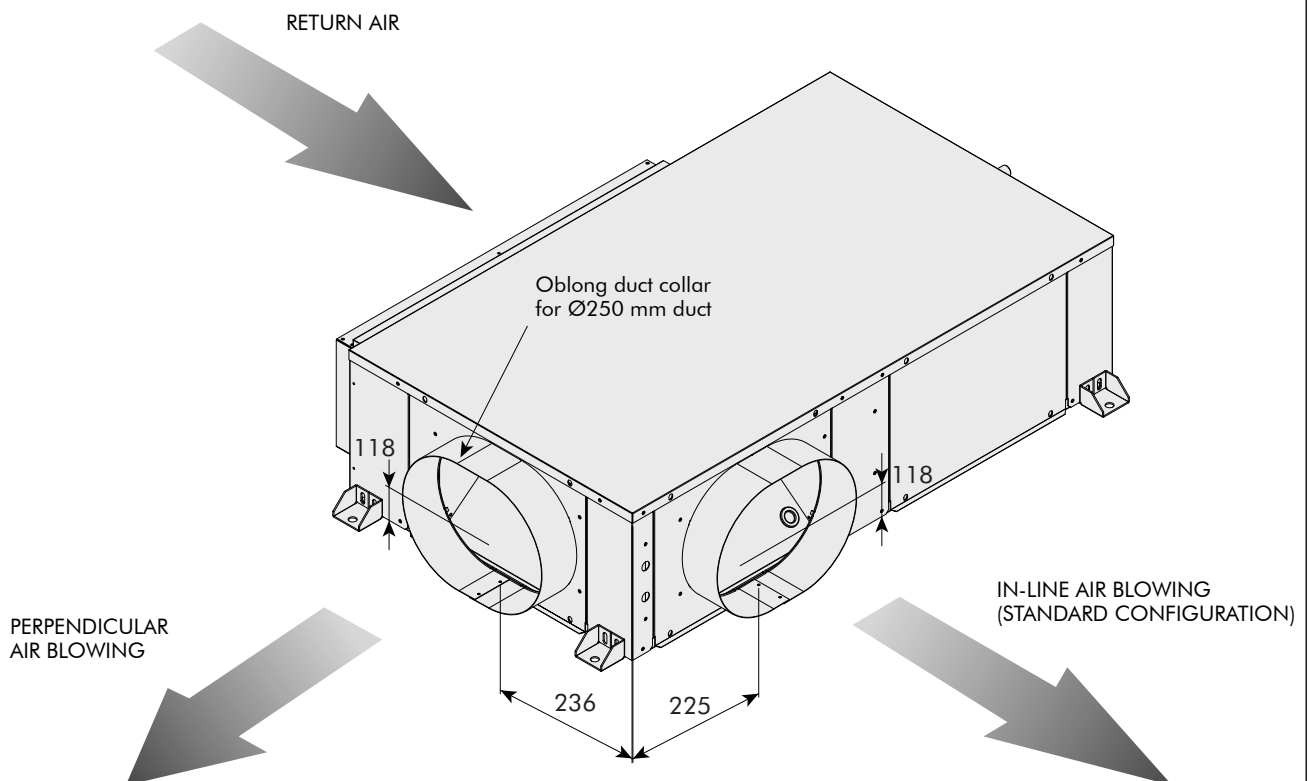

Air duct connection - Return side - Unit without plenum

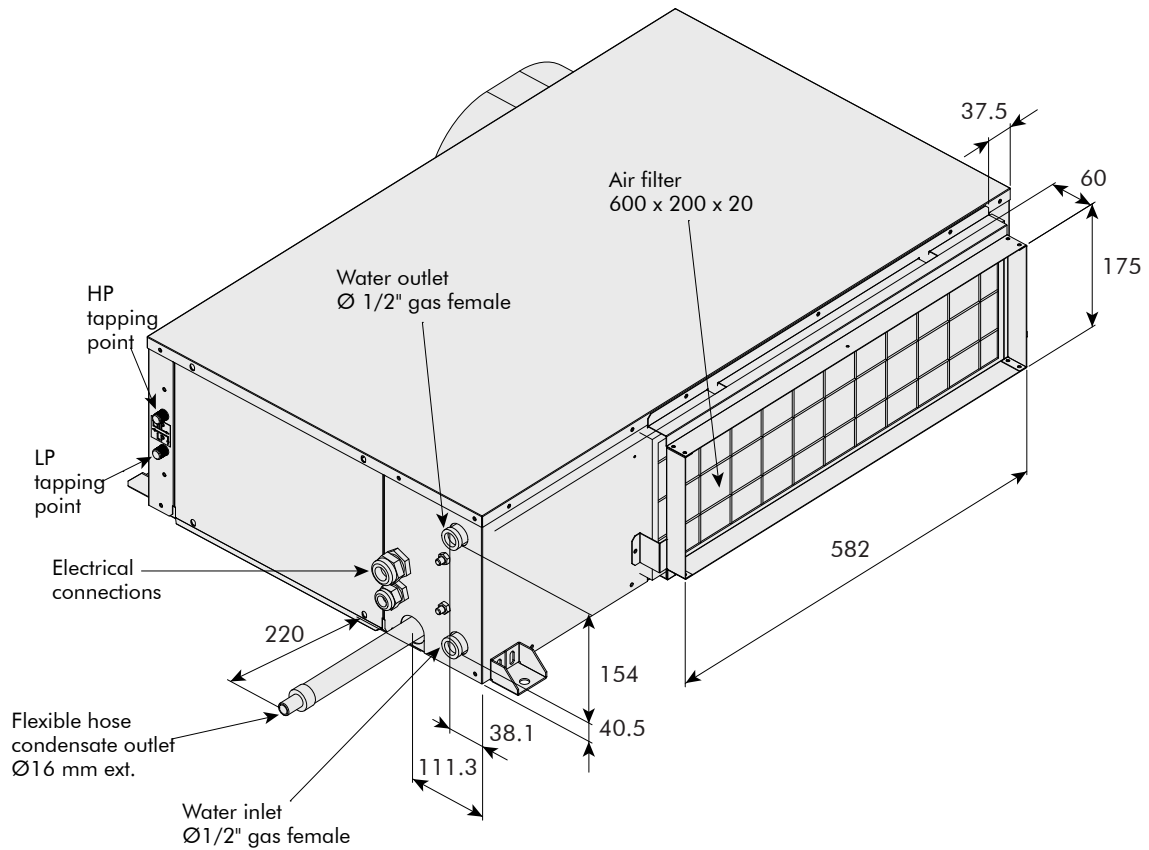

Air duct connection - Return side - Unit with plenum (optional)

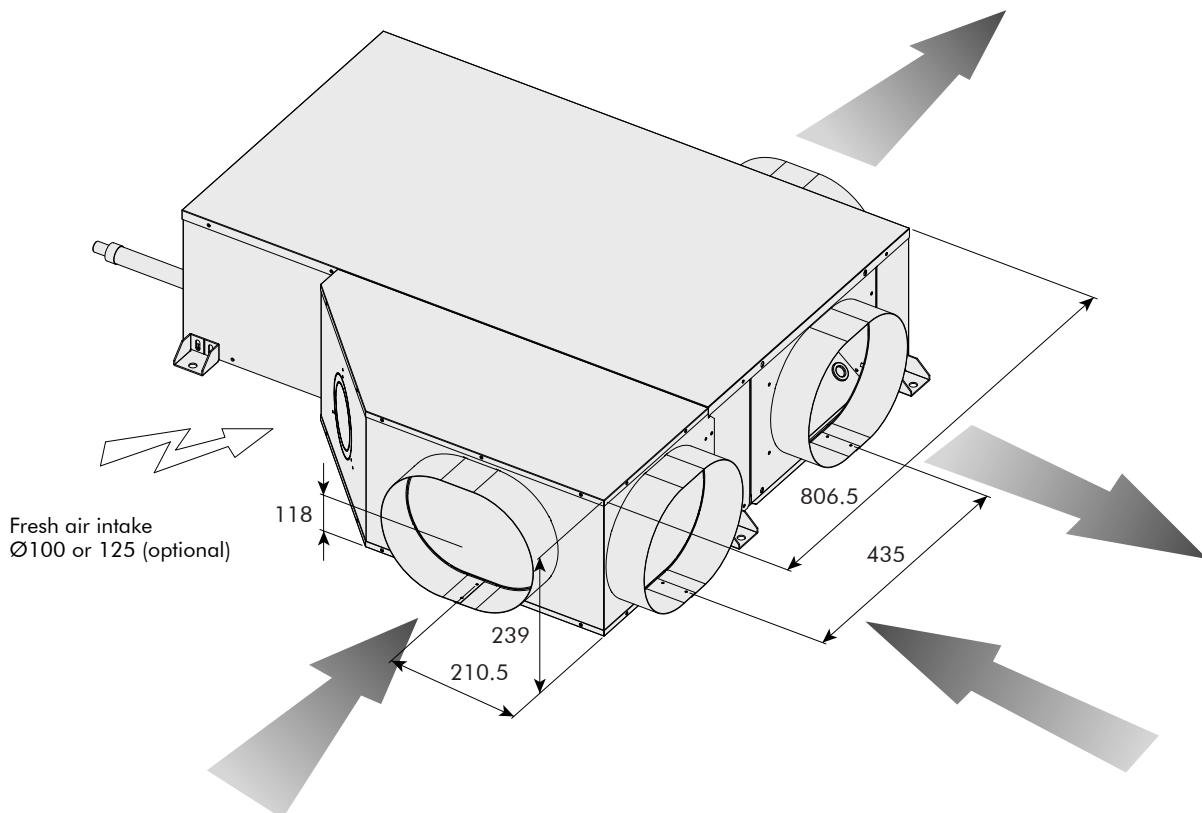

Dimensions (mm) - HRW 019 to 072

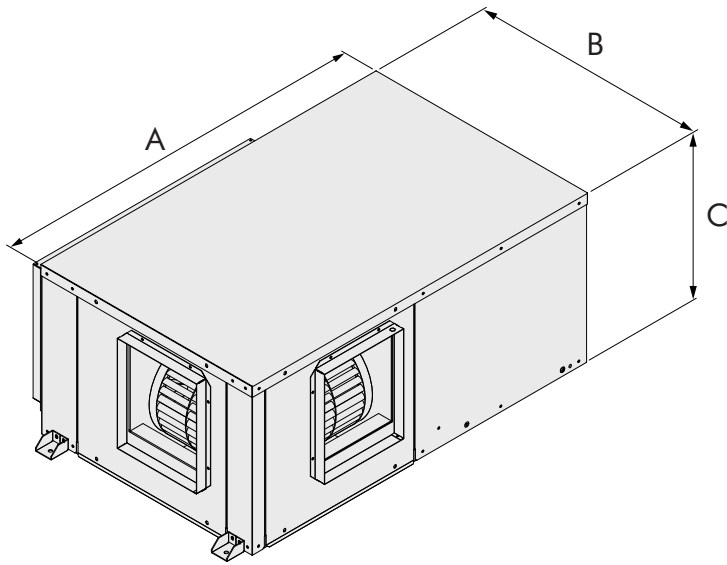

HRW sizes	A	B	C
019-024	900	600	439
030-036	1050	660	460
042-048-060-072	1250	705	513

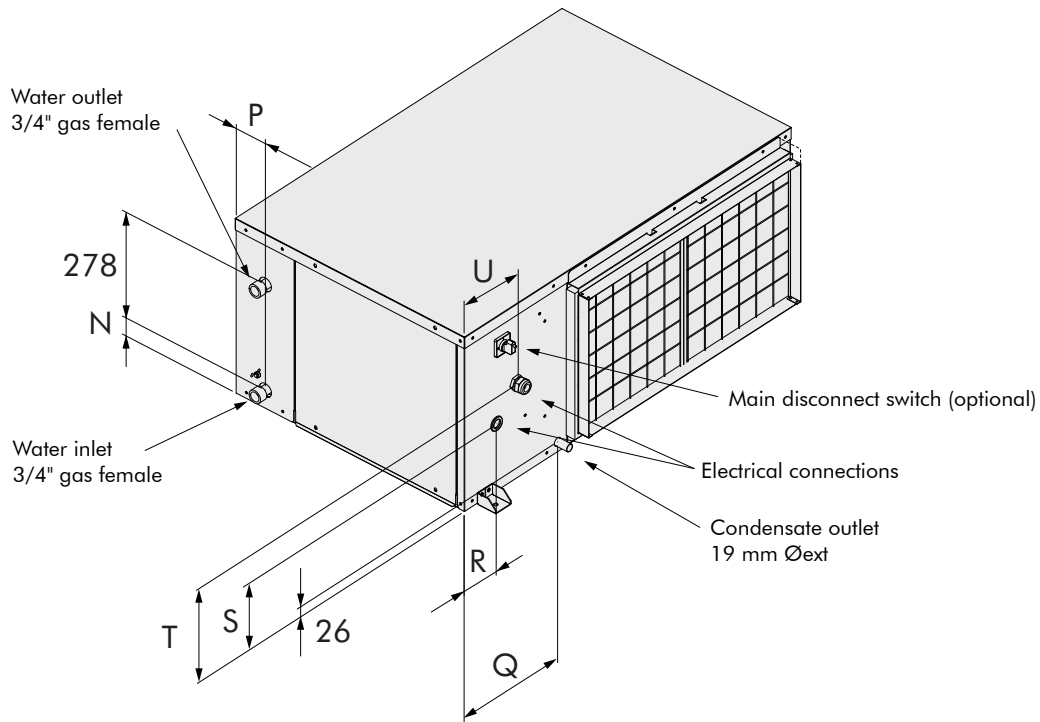

HRW sizes	N	P	Q	R	S	T	U
019-024	65	85	250	63	132	200	128
030-036	48	85	300	102	178	253	165
042-048-060-072	48	125	300	102	232	307	165

Weight (kg)

HRW sizes	019	024	030	036	042	048	060	072
Weight - Operating	80	85	100	112	133	140	144	149

Dimensions (mm) - HRW 019 à 072 (continued)

Discharge air duct collar

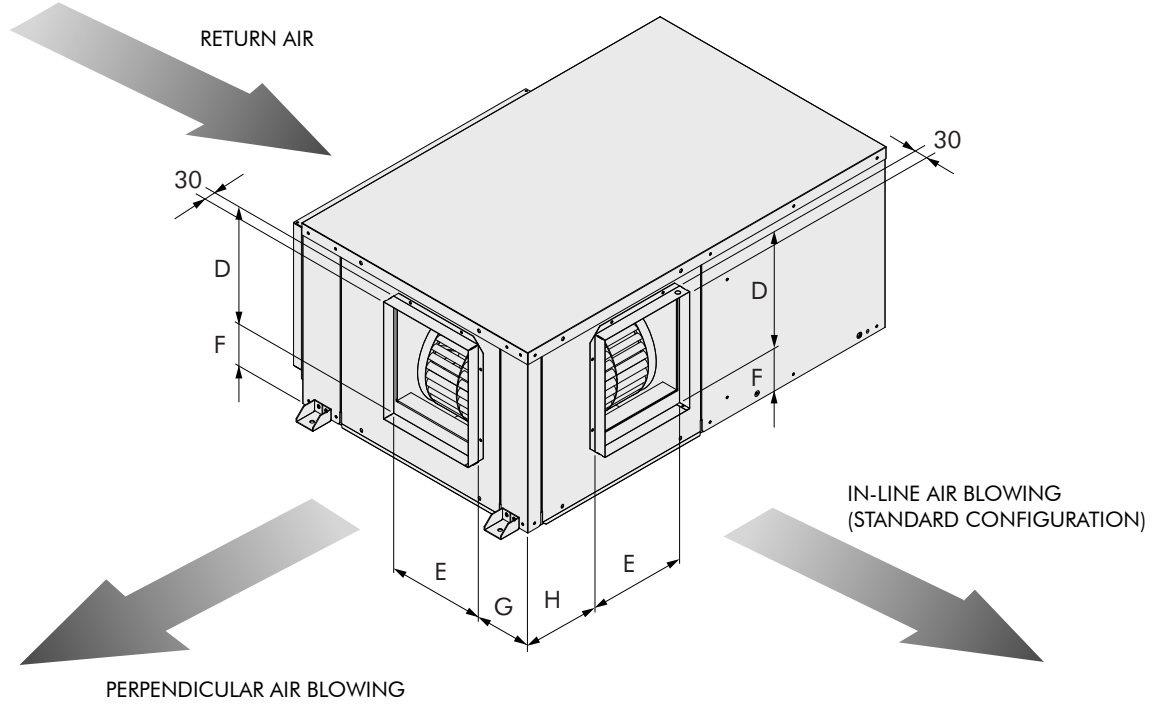

HRW sizes	D	E	F	G	H
019-024	249	249	102	117	160
030-036	299	249	109	144	196
042	299	249	124	165	259
048-060-072	299	349	166	110	215

Return air duct collar

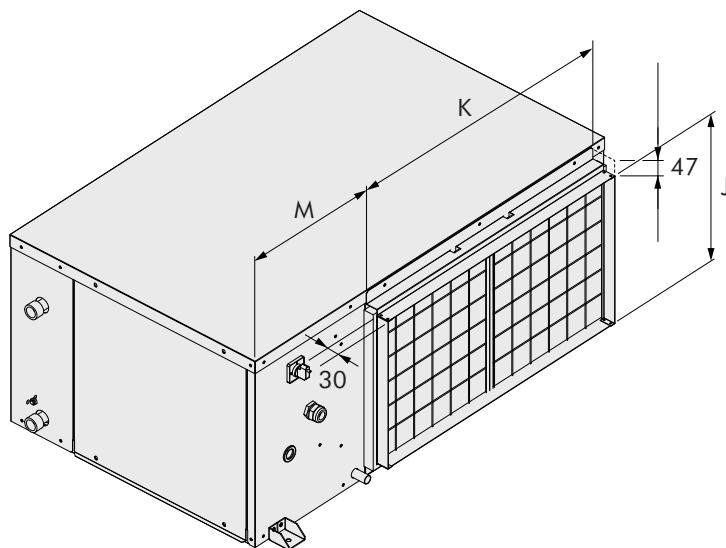

HRW sizes	J	K	M
019-024	345	582	280
030-036	365	682	331
042-048-060-072	419	882	331

Dimensions (mm) - HRW 096 & 120

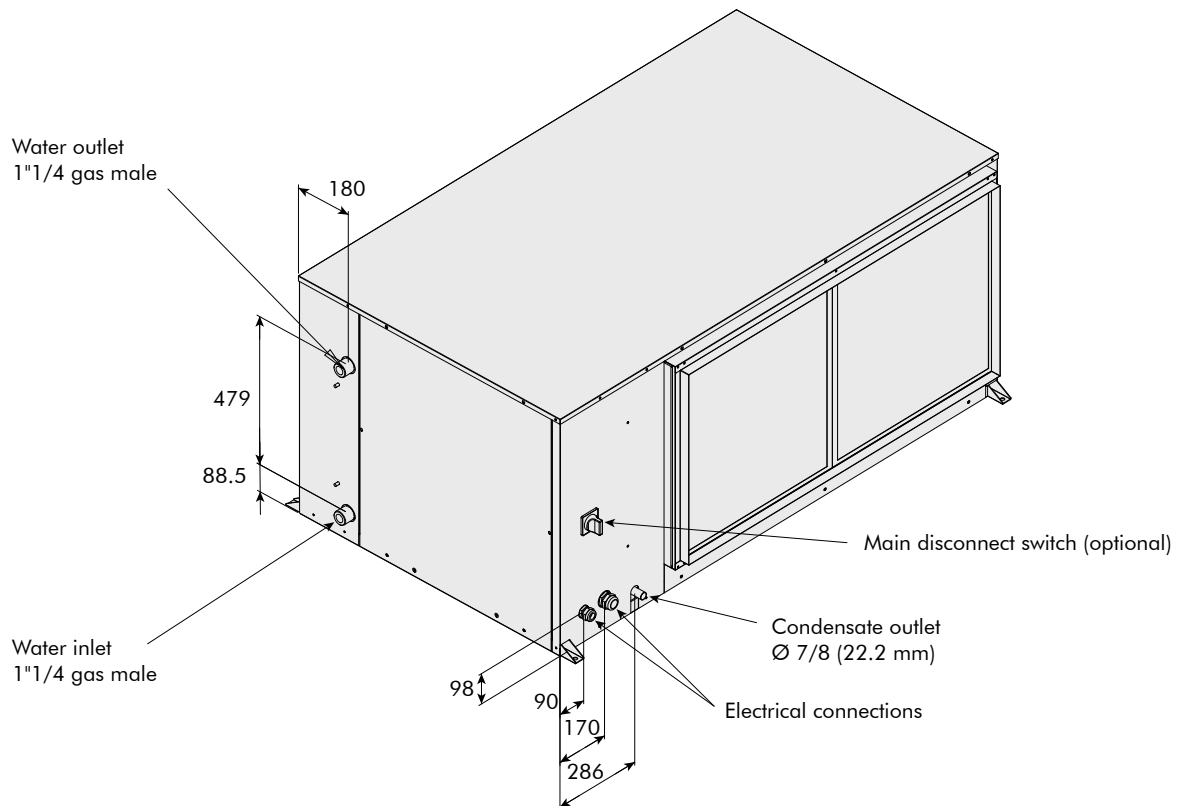
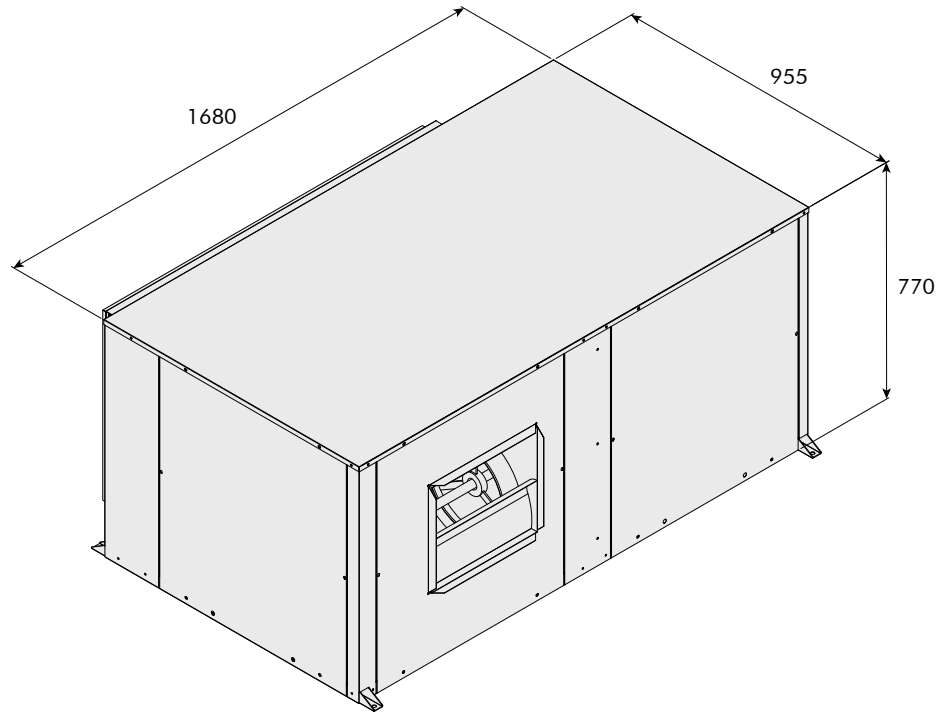

Weight (kg)

HRW sizes	096	120
Weight - Operating	253	262

Dimensions (mm) - HRW 096 & 120 (continued)

Discharge air duct collar

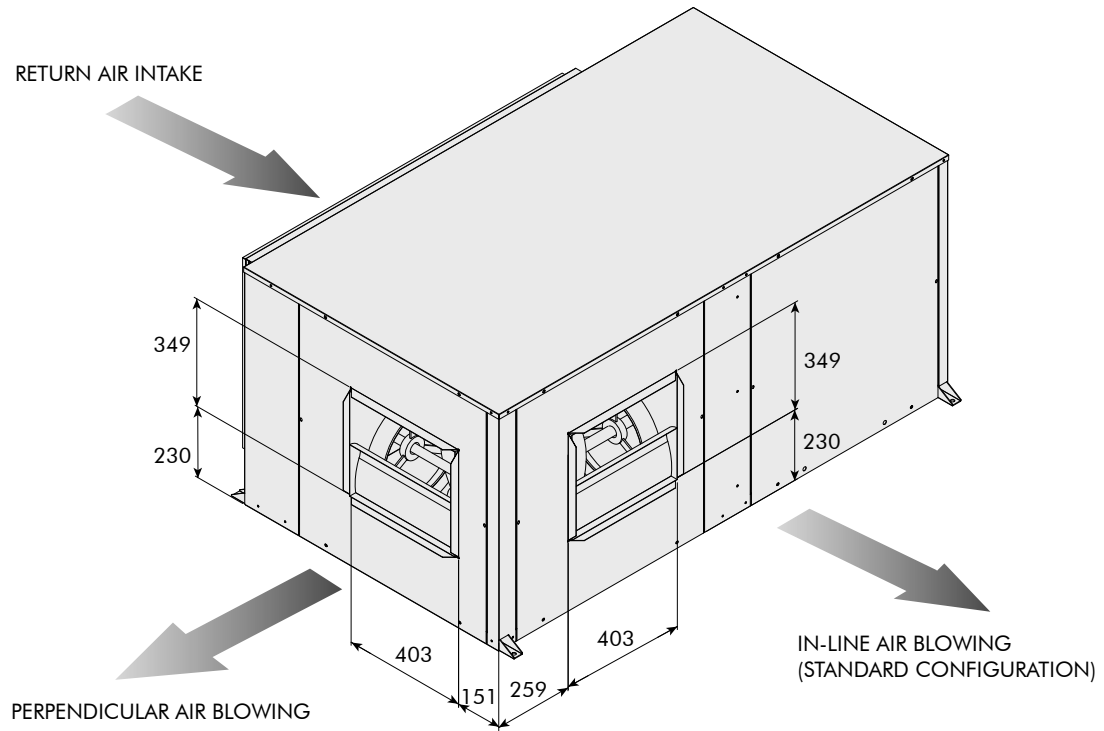

Return air duct collar

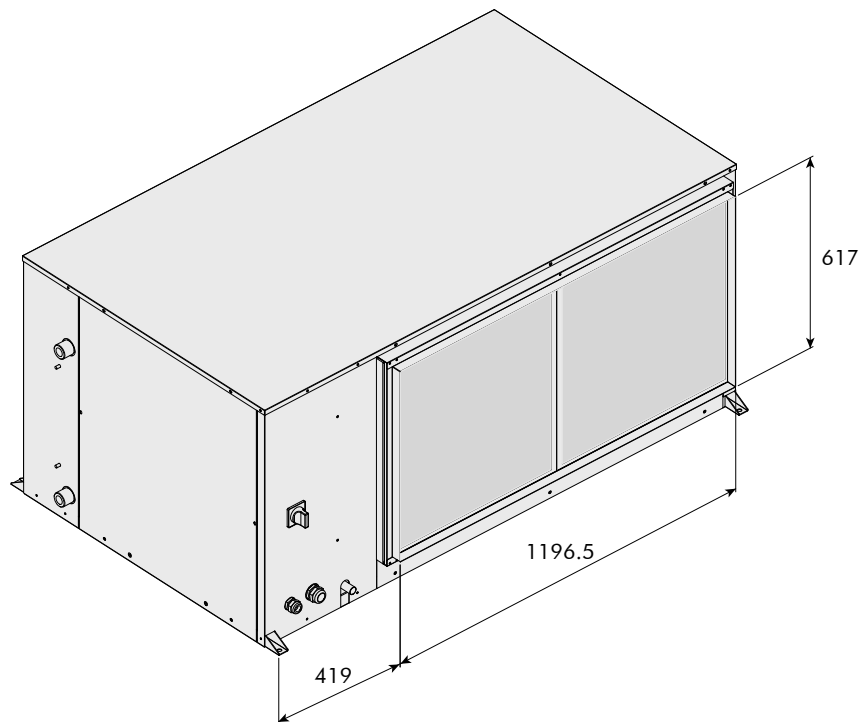

Minimum Installation Clearances

When installing the unit, leave enough side clearances for service and maintenance works (see figure below) in order to easily remove the filter and the access panels of electrical box, compressor, fan. Also, leave enough space for water, electricity and duct connection.

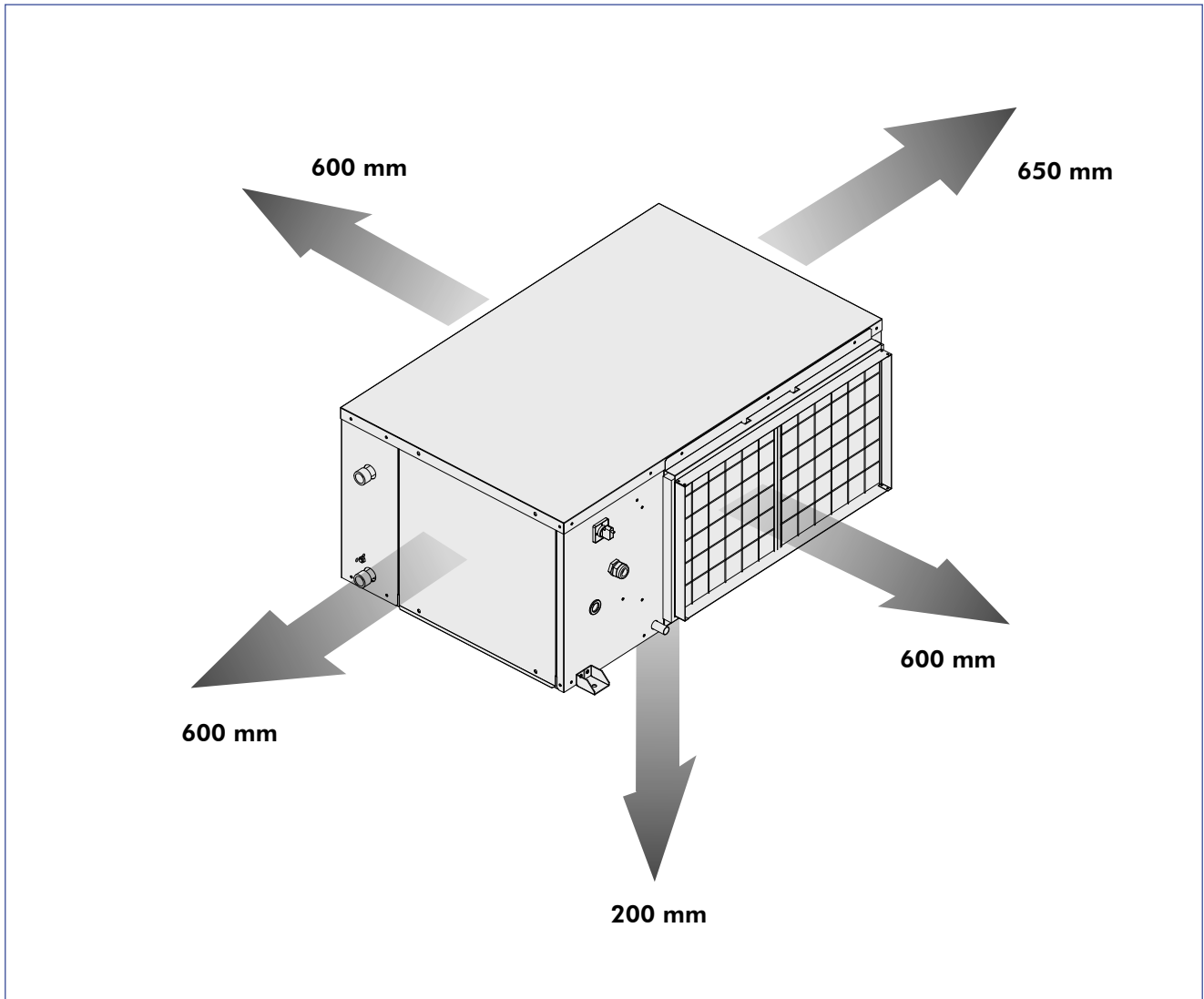

Airwell

As part of our ongoing product improvement programme, our products are subject to change without prior notice. Non contractual photos.



CAC Export Department
42 cours Jean-Jaurès
17800 Pons - France
Tel. : +33 (0)5 46 92 33 33 - Fax : +33 (0)5 46 91 26 44

Your distributor :