

AIR-COOLED SCROLL MODULAR CHILLER

TECHNICAL SERVICE MANUAL

R410A (30kW-250kW) 50Hz

Models:

MCC(D)H30A-TA3SL

MCC(D)H65A-SA3L

MCCH130A-SA3L

MCCH185A-SA3

MCCH250A-SA3T



Content

1 General information	3
2. Features.....	5
3. Specification	9
4 Dimension	17
5 Refrigeration system drawing.....	27
6. Piping diagram.....	30
7 Wiring diagrams.....	36
8 Electric characteristics	50
9 Capacity tables	51
10 Troubleshooting.....	61
11 Installation.....	77
12 Commissioning.....	104
13 Maintenance	105
14 Control system	109
Appendix	166

1 General information

1.1 Nomenclature

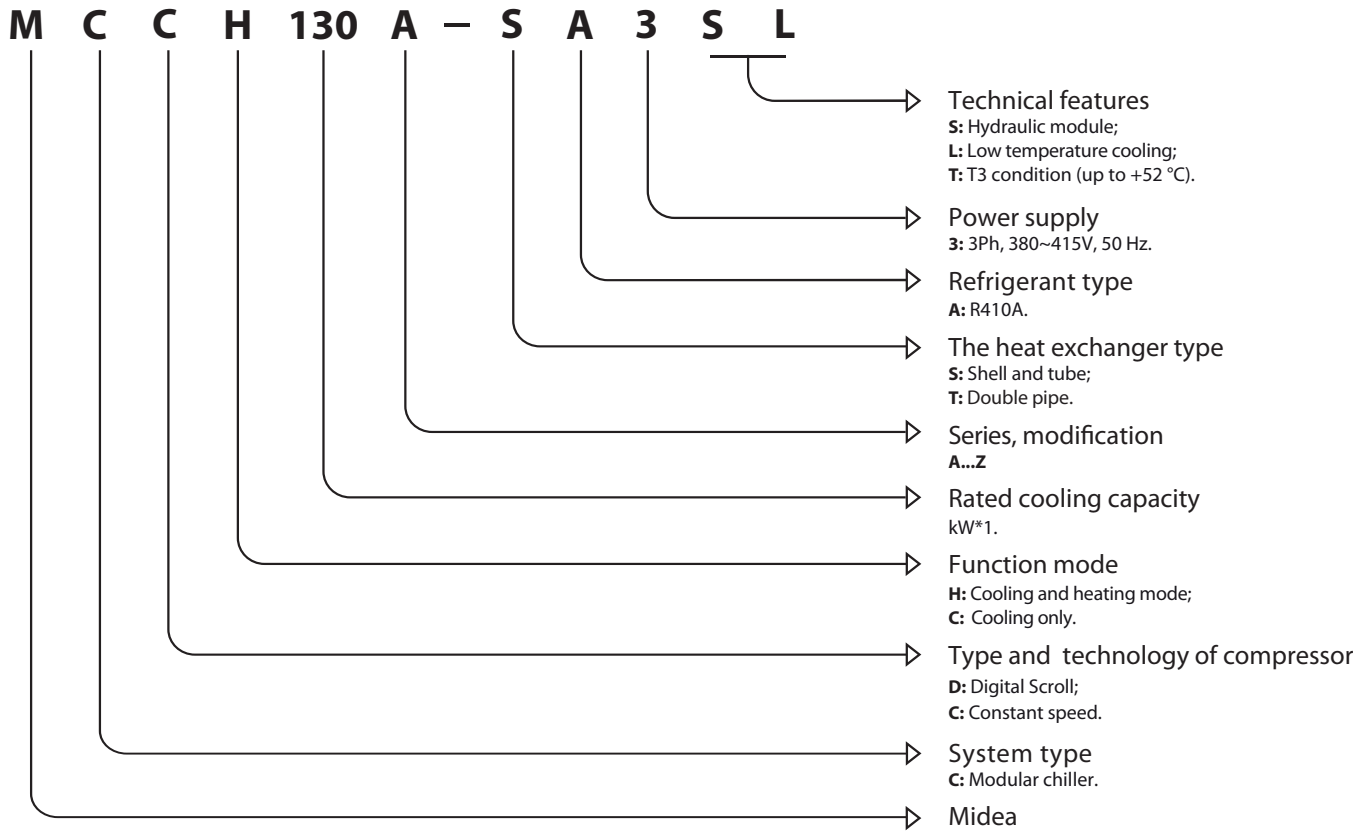

1.2 Product schedule

No	Model	Power supply	Heat exchanger type	Maximum combinations	Maximum capacity(kW)	Wired controller
1	MCCH30A-TA3SL	380~415V/3ph/50Hz	Double pipe	1	30	KJR-120A/MBE
2	MCDH30A-TA3SL	380~415V/3ph/50Hz	Double pipe	1	30	KJR-120A/MBE
3	MCCH65A-SA3L	380~400V/3ph/50Hz	Shell and tube	16	1040	KJR-120A/MBE
4	MCCD65A-SA3L	380~415V/3ph/50Hz	Shell and tube	16	1040	KJR-120A/MBE
5	MCCH130A-SA3L	380~400V/3ph/50Hz	Shell and tube	8	1040	KJR-120A/MBE
6	MCCH185A-SA3	380~400V/3ph/50Hz	Shell and tube	5	1000	KJR-120A/MBE
7	MCCH250A-SA3T	380~400V/3ph/50Hz	Shell and tube	8	2000	KJR-120A/MBE

1.3 External appearance:

**MCCH30A-TA3SL
MCDH30A-TA3SL**



**MCCH65A-SA3L
MCCD65A-SA3L**



MCCH130A-SA3L



MCCH185A-SA3



MCCH250A-SA3T



2. Features

1). Low ambient temperature cooling function (Available for MCC(D)H30A-TA3SL, MCC(D)H65A-SA3L, MCCH130A-SA3L)

The ambient temperature is down to -10°C in cooling mode, and heating down to -10°C ambient by added one board (see picture1). Wide ambient temperature range are available by adjustable address between different conditions to meet different requirements.

Mode		Ambient temp.
Cooling	Normally (S8 address OFF)	$10\sim 46^{\circ}\text{C}$
	※ Low temp. (S8 address ON)	$-10\sim 46^{\circ}\text{C}$
Heating		$-10\sim 21^{\circ}\text{C}$

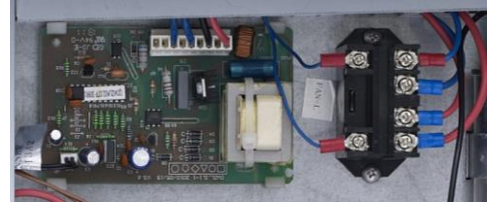

2). Wide range of outlet water temperature (For the module with KJR-120A/MBE)

Cooling: $5\sim 17^{\circ}\text{C}$ (Set in factory), $0\sim 17^{\circ}\text{C}$ can be available by switch the S5 on PCB, the antifreeze must be put into pipeline.

Heating: $40\sim 50^{\circ}\text{C}$ (Set in factory), $22\sim 50^{\circ}\text{C}$ can be available by switch the address.

Mode		Outlet water temp.
Cooling(S5 address)	Normally(OFF)	$5\sim 17^{\circ}\text{C}$
	Low water temp.(ON)	$0\sim 17^{\circ}\text{C}$
Heating(S4 address)	Normally(OFF)	$40\sim 50^{\circ}\text{C}$
	Low water temp. (ON)	$22\sim 50^{\circ}\text{C}$

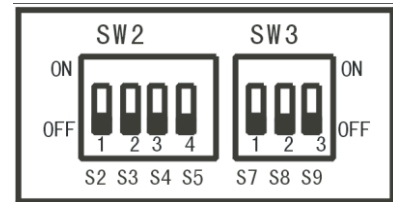

3). Built-in hydraulic module (Available for MCC(D)H30A-TA3SL)

The unit built-in hydraulic module to simplified installation, save space and beautification appearance, simultaneous effectively reduce installation costs and covering area.

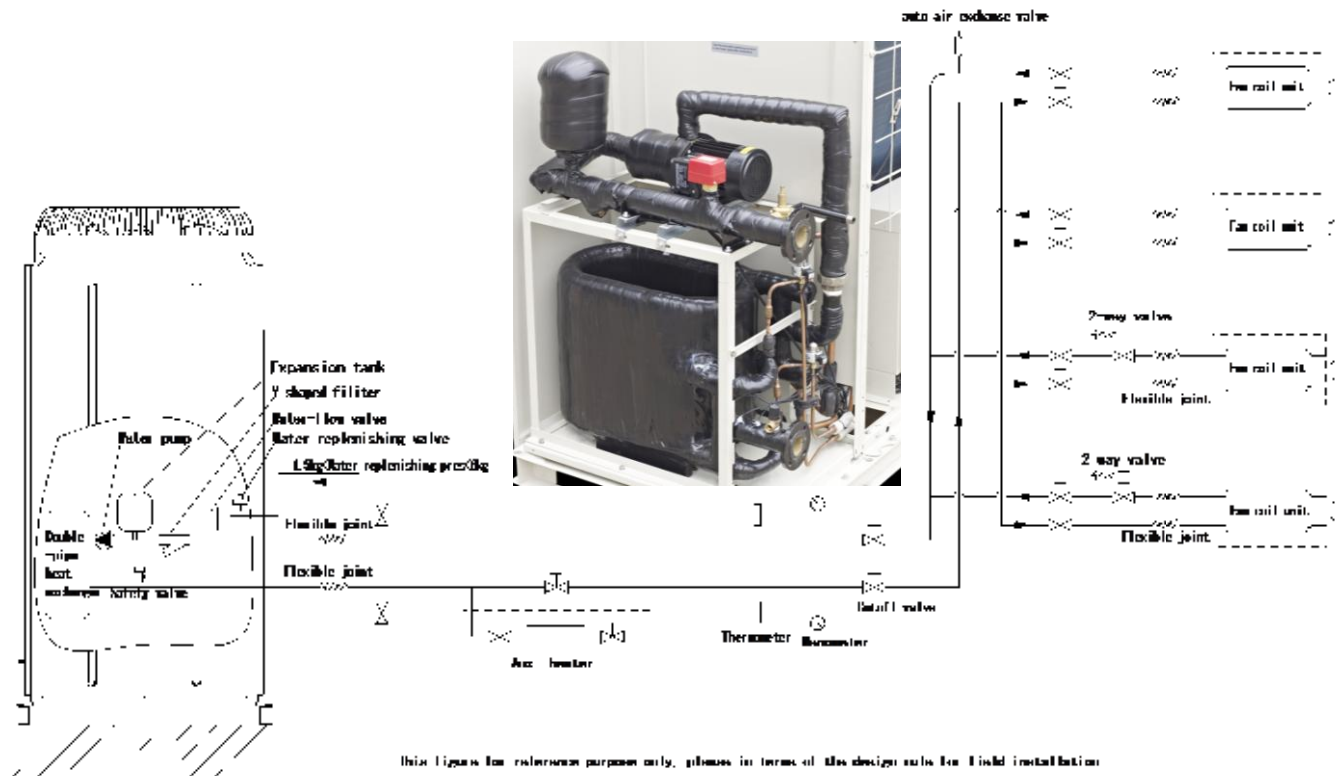

4).Humanized remote control (For the module with KJR-120A/MBE)

S7 address on PCB should be switched to ON to realize remote control, which including remote ON/OFF, remote heating and cooling mode selection, remote alarm. The customer can simply and conveniently control the chiller and acquire the running information on real time in door.

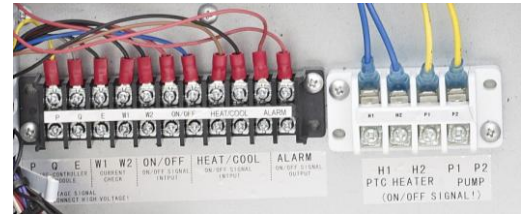

5)Digital scroll technique, new type modular air-cooled chiller system.

Capacity output is controlled depending on controlling compressor to on/off in traditional modular air-cooled chiller system control. The precision of the control mode is not very good, and the compressor is frequently on and off, which is very bad for the compressor's life.

Digital scroll modular air-cooled chiller system breaks traditional design, which is inconceivably designed with digital scroll compressor and constant scroll compressor parallel connection. The system can achieve linear capacity output within 0.5%-100%, the scope is widest in industry. When the system operates at the part-load, the system can accurately adjust cooling and heating capacity output basing on actual requirement of the indoor room.

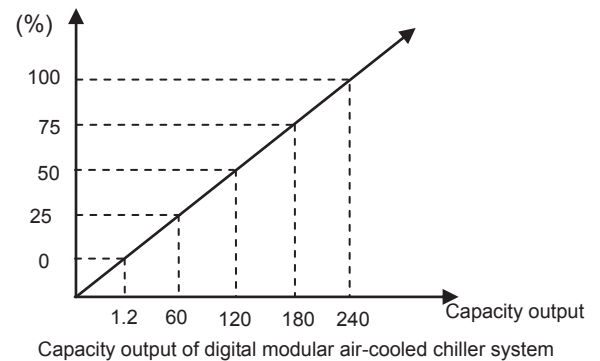
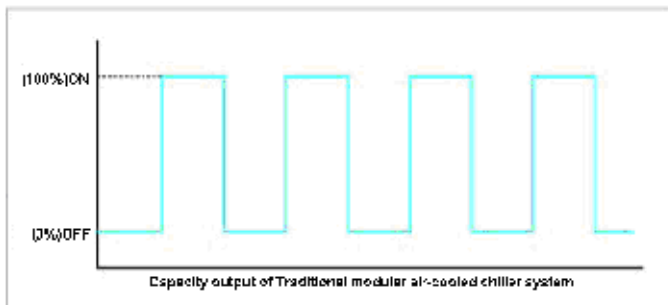

6).Modular design, flexible combination, more convenient for design and installation.

The unit adopt modular design, which can makes more unit connect together. The unit can be combined max. 16 separate module(30, 65kW module) or 8 module (250kW module).Cooling(heating) capacity can be increased step by step by 5kW per each time within 30kW-2000kW,meanwhile every separate module can be operated as main unit, also each module can be a slave unit with modules combination, more convenient for design and installation.



7).The maximum combination of the system consists of 1 main unit and 15 slave units for slave units 65kW module, 1 main unit and 7 slave units for 130kW module, 1 main unit and 4 for 185kW module, 1 main unit and 7 slave units for 250kW module.

Easy connection between main unit and slave units.

All the units can be connected together with a wired controller in series type. Using three-core shielded twisted wire as communication wire.

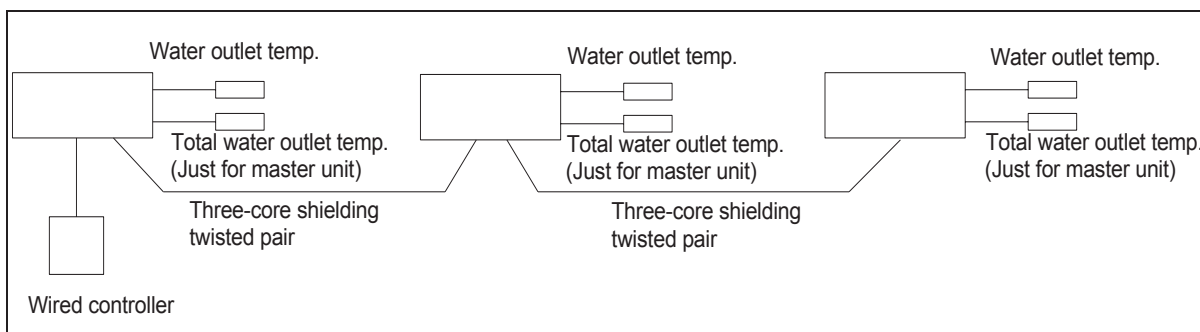

8).Environmental care

Ecological R410A refrigerant.

- Chlorine-free and environmental friendly refrigerant, zero ozone depletion potential.
- High density refrigerant, therefore, less refrigerant required.
- Leak-tight refrigerant circuit, Brazed refrigerant connections for increased leak-tightness.

9) Economical operation

New design adopts electronic expansion valve precise refrigerant control in wider range. Electronic expansion valve allows operation at lower condensing pressure, adjustment can be made fast linear response, making the system more stable output, the indoor temperature more uniform, and enhance human comfortable.



10).Compact structure

Air cooled modular chiller structure are compact, light weight. The system adopts double pipe, shell and tube heat exchanger, not only greatly enhanced the transfer performance, but also reduce the unit weight, the lightest single module only has 380kg.

11).Backup function

When unit is failed.

- If master unit fails, all the units will stop.
- If one slave unit fails, this unit will stop but the others will keep running.
- When the master unit fails, any of the slave one can be set as the master unit by manual setting.

When unit is under protection

- If master unit's protection occurs, this unit will stop but the others will keep running.
- If slave unit's protection occurs, this unit will stop but the others will keep running.
- (Except PE, P9 protection happen)
PE: Low temperature protection of evaporator.
P9: Outlet and inlet water temperature difference protection.

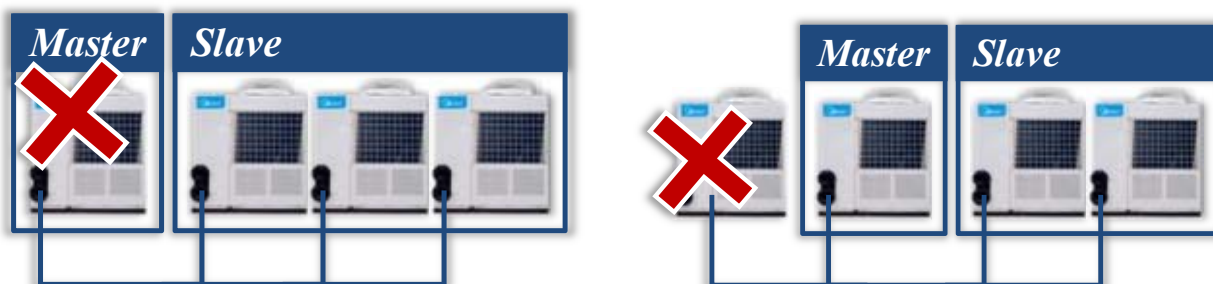

12).Strong micro-computer intelligent control and monitor function

Optimizing the design of system and using varieties of protection devices, to make the system more safe and reliable.

13). Superior reliability

System will be more reliable with new type efficient heat exchanger.

Evaporator 30kW module adopts double pipe heat exchanger , evaporator of 65kW ,130kW, 185kW and 250kW modules adopt shell and tube heat exchanger.

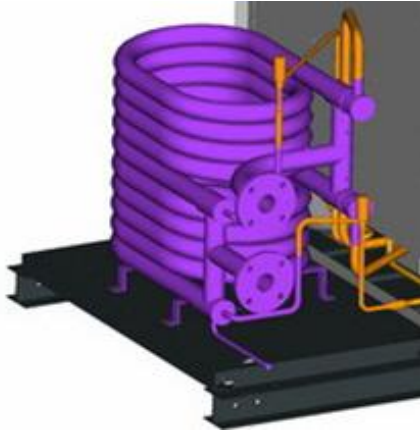

Double pipe heat exchanger

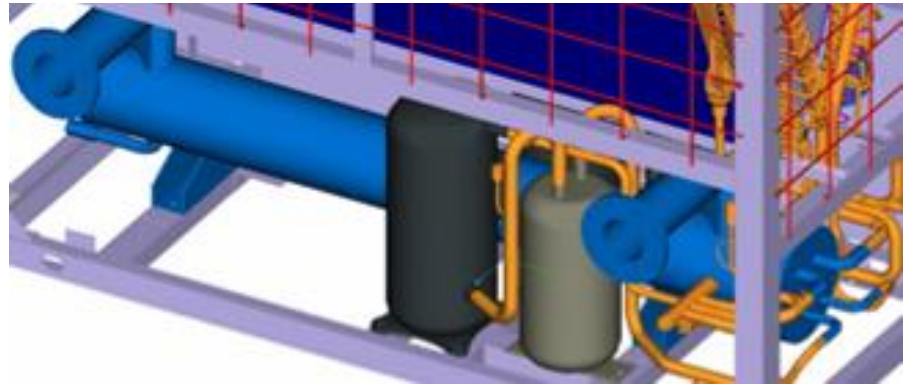

Shell and tube heat exchanger

14). Applicable temperature range

Mode	Ambient temperature range	Water outlet temperature range	Application module
Cooling	10°C ~46°C	0~17°C(The antifreeze must be added)	The module with KJR-120A/MBE
	-10°C ~46°C	5°C ~17°C	Available for MCC(D)H30A-TA3SL, MCC(D)H65A-SA3L , MCCH130A-SA3L
Heating	-10°C ~21°C	22°C ~50°C	The module with KJR-120A/MBE

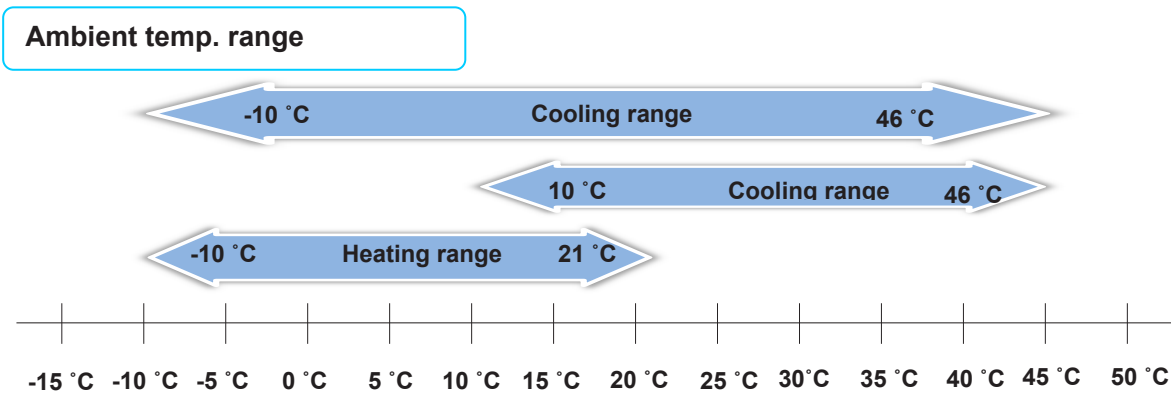

Chilled outlet water temperature can be adjusted by wired controller according to customer's demand.

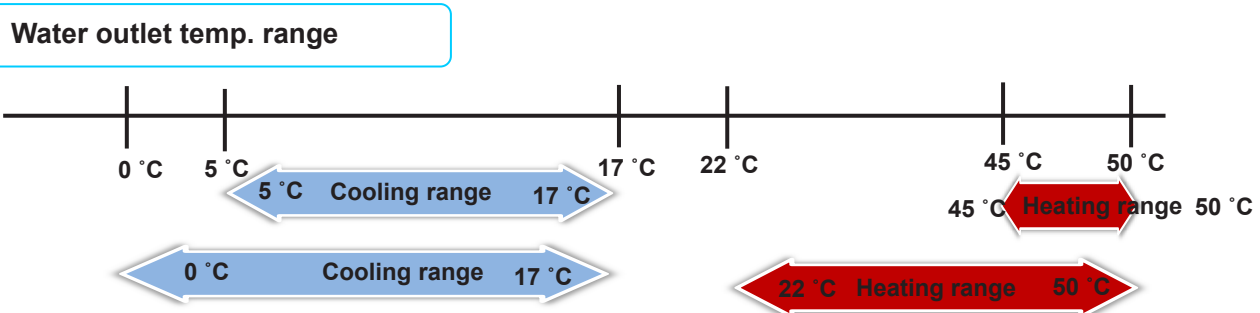

3. Specification

Model			MCCH30A-TA3SL	MCDH30A-TA3SL
Cooling Capacity		kW	30	30
		Btu/h	102,300	102,300
Heating Capacity		kW	32	32
Power supply		V/Ph/Hz	380-415/3/50	
Power supply	Manual switch	A	50	
	Fuse	A	36	
Compressor	Type		Fixed speed	Digital Scroll + Fixed speed
	Quantity	Pieces	1+1	1+1
	Model		ZP67KCE-TFD-522	ZPD67KCE-TFD-532/ ZP67KCE-TFD-522
	Brand		Copeland	
	Capacity	W	16200×2	
	Input	W	5200×2	
	Rate current(RLA)	A	9.1×2	
	Locked rotor Amp(LRA)	A	74×2	
Power input	Cooling	kW	10	10
	Cooling rated current	A	16.3	16.3
	Heating	kW	9.8	9.8
	Heating rated current	A	16	16
Max. Input consumption		kW	13.4	
Max. Current		A	22.5	
Refrigerant	Type		R410A	
	Weight	kg	3.5×2	
	Refrigerant control		EXV	
Condenser (Air side)	Air side heat-exchanger type		Fin-coil	
	Quantity of fan motor	Pieces	1	
	Air flow	×10 ³ m ³ /h	12	
	Fan motor input	kW	0.55	
Evaporator (Water side)	Water side heat-exchanger type		Double-pipe	
	Water resistance loss	kPa	/	
	Water inlet/outlet pipeline inside normal diameter	mm	DN40	
		inch	1-1/2"	
	Water flow	m ³ /h	5.2	5.2
	Max. Pressure	MPa	1	
Water pipe connection type		Flexible joint		
Dimension	Net(W×H×D)	mm	1514×1865×841	
		inch	59.6×73.4×33.1	
	Packing(W×H×D)	mm	1590×2065×995	
		inch	62.6×81.3×39.2	
Weight	Net weight	kg	430	
	Operation weight	kg	450	
Connection wire	Power wire	mm ² ×No.	10×4+6×1	
	Signal wire	mm ² ×No.	0.75×3-core with shielding	
Control type			Wired controller	

Safety protection device		1) Protection for over-high discharge pressure. 2) Protection for over-low suction pressure. 3) Power supply phase sequence protection. 4) Anti-freezing protection in cooling mode. 5) Anti-freezing protection in Winter. 6) Protection for compressor over current. 7) Protection for compressor overload. 8) Outlet and inlet water temperature difference protection. 9) Compressor discharge temperature protection. 10) Water flow cut-off protection. 11) Sensor malfunction protection. 12) Low ambient temperature drive-up protection 13) Low temperature protection of shell and tube heat exchanger.
Noise level(semi-anechoic)	dB(A)	67
Operation water temp	°C	Cooling: 0~17(Less than 5°C must add antifreeze) Heating: 22~50
Ambient temp	°C	Cooling: -10~46 Heating: -10~21

Note:

Please refer to the water flow volume in the above table strictly to design and install.

All the above data is measured base on the following working condition:

1. Cooling mode: water side fouling factor: $0.086\text{m}^2 \cdot ^\circ\text{C}/\text{kW}$, chilled water inlet/outlet: $12^\circ\text{C} / 7^\circ\text{C}$, and outdoor ambient temp. of 35°C DB.

2. Heating mode: water side fouling factor: $0.086\text{m}^2 \cdot ^\circ\text{C}/\text{kW}$, warm water inlet/outlet: $40^\circ\text{C} / 45^\circ\text{C}$, and outdoor ambient temp. 7°C DB/ 6°C WB.

Model			MCCH65A-SA3L	MCDH65A-SA3L		
Cooling Capacity		kW	65	65		
Heating Capacity		kW	69	69		
Power input	Cooling	kW	20.4	20.4		
	Cooling rated current	A	36.5	36.5		
	Heating	kW	21.5	21.5		
	Heating rated current	A	37.2	37.2		
Power supply		V/Ph/Hz	380-400/3/50	380-415/3/50		
Power supply	Manual switch	A	150	150		
	Fuse	A	100	100		
Max. Input consumption		kW	27.9	27.1		
Max. Current		A	50	51.7		
Compressor	Type		Scroll (fixed speed)	Scroll (fixed speed + digital scroll)		
	Brand		Danfoss	Copeland		
	Model		SH140A4ALC	ZP144KCE-TFD-522 / ZPD72KCE-TFD-433 / ZP67KCE-TFD-420		
	Quantity	Pieces	2	3		
	Capacity	W	34700×2	36	17	16.3
	Input	W	10860×2	10.8	5.75	5.2
	Rate current(RLA)	A	21.4×2	18.7	9.8	9.1
	Locked rotor Amp(LRA)	A	147×2	144	82.4	74
Refrigerant	Type		R410A	R410A		
	Refrigerant control		EXV+ capillary	EXV+ capillary		
	Weight	kg	7.0×2	7.0×2		
Condenser (Air side)	Air side heat-exchanger type		Fin-coil	Fin-coil		
	Quantity of fan motor	Pieces	2	2		
	Air flow	×10 ³ m ³ /h	24	24		
	Fan motor input	kW	0.865×2	0.865×2		
Evaporator (Water side)	Water side heat-exchanger type		Shell and tube	Shell and tube		
	Water resistance loss	kPa	15	15		
	Water inlet/outlet pipeline inside normal diameter	mm	DN100	DN100		
	Water flow	m ³ /h	11.2	11.2		
	Max. Pressure	MPa	1	1		
	Water pipe connection type		Flexible joint	Flexible joint		
Dimension	Net(W×H×D)	mm	2000×1880×900	2000×1880×900		
	Packing size(W×H×D)	mm	2106×2090×998	2106×2090×998		
Weight	Net weight	kg	580	610		
	Operation weight	kg	650	680		
Connection	Power current	mm ²	25×4+16×1	25×4+16×1		
	Signal wiring	mm ²	0.75×3-core with shielding	0.75×3-core with shielding		
Control type			Wired controller	Wired controller		

Safety protection device		1) Protection for over-high discharge pressure. 2) Protection for over-low suction pressure. 3) Power supply phase sequence protection. 4) Anti-freezing protection in cooling mode. 5) Anti-freezing protection in Winter. 6) Protection for compressor over current. 7) Protection for compressor overload. 8) Outlet and inlet water temperature difference protection. 9) Compressor discharge temperature protection. 10) Water flow cut-off protection. 11) Sensor malfunction protection. 12) Low ambient temperature drive-up protection 13) Low-temperature protection of shell and tube heat exchanger.
Noise level	dB(A)	67
Operation water temp	°C	Cooling: 0~17 (Less than 5°C must add antifreeze) Heating: 22~50
Ambient temp	°C	Cooling: -10~46 Heating: -10~21

Note:

Please refer to the water flow volume in the above table strictly to design and install.

All the above data is measured base on the following working condition:

1. Cooling mode: water side fouling factor: $0.086\text{m}^2 \cdot ^\circ\text{C}/\text{kW}$, chilled water inlet/outlet: $12^\circ\text{C} / 7^\circ\text{C}$, and outdoor ambient temp. of 35°C DB.

2. Heating mode: water side fouling factor: $0.086\text{m}^2 \cdot ^\circ\text{C}/\text{kW}$, warm water inlet/outlet: $40^\circ\text{C} / 45^\circ\text{C}$, and outdoor ambient temp. 7°C DB/ 6°C WB.

Model			MCCH130A-SA3L
Cooling Capacity		kW	130
		Btu/h	443,560
Heating Capacity		kW	138
Power supply		V/Ph/Hz	380-400/3/50
Power supply	Manual switch	A	250
	Fuse	A	200
Compressor	Type		Fixed speed Scroll
	Quantity	Pieces	4
	Model		SH140A4ALC
	Brand		Danfoss
	Capacity	kW	34.7×4
	Input	kW	10860×4
	Rate current(RLA)	A	21.4×4
	Locked rotor Amp(LRA)	A	147×4
Power input	Cooling	kW	40.8
	Cooling rated current	A	73
	Heating	kW	43.0
	Heating rated current	A	74.4
Max. Input consumption		kW	55.5
Max. Current		A	93.8
Refrigerant	Type		R410a
	Weight	kg	7×4
	Refrigerant control		EXV+ capillary
Condenser (Air side)	Air side heat-exchanger type		Fin-coil
	Quantity of fan motor	Pieces	4
	Air flow	×10 ³ m ³ /h	48
	Fan motor input	kW	0.88×4
Evaporator (Water side)	Water side heat-exchanger type		Shell and tube
	Water resistance loss	kPa	25
	Water inlet/outlet pipeline inside normal diameter	mm	DN65
		inch	2-1/2"
	Water flow	m ³ /h	22.4
	Max. Pressure	MPa	1
	Water pipe connection type		Flexible joint
Dimension	Net(W×H×D)	mm	2000×2080×1685
		inch	78.7×82.3×66.3
	Packing(W×H×D)	mm	2090×2240×1755
		inch	82.3×88.2×69

Weight	Net weight	kg	1150
	Operation weight	kg	1270
	Power wire	mm ² ×No.	35×3+16×2
	Signal wire	mm ² ×No.	0.75x3-core
Control type			Wired controller
Safety protection device			1) Protection for over-high discharge pressure. 2) Protection for over-low suction pressure. 3) Power supply phase sequence protection. 4) Anti-freezing protection in cooling mode. 5) Anti-freezing protection in Winter. 6) Protection for compressor over current. 7) Protection for compressor overload. 8) Outlet and inlet water temperature difference protection. 9) Compressor discharge temperature protection. 10) Water flow cut-off protection. 11) Sensor malfunction protection. 12) Low ambient temperature drive-up protection 13) Low-temperature protection of shell and tube heat exchanger.
Noise level(semi-anechoic)		dB(A)	74
Operation water temp		°C	Cooling : 0~17 (Less than 5°C must add antifreeze) Heating : 22~50
Ambient temp		°C	Cooling : -10~46 Heating : -10~21

Note:

Please refer to the water flow volume in the above table strictly to design and install.

All the above data is measured base on the following working condition:

- Cooling mode: water side fouling factor: 0.086m²·°C/kW, chilled water inlet/outlet: 12°C / 7°C, and outdoor ambient temp. of 35°C DB.
- Heating mode: water side fouling factor: 0.086m²·°C/kW, warm water inlet/outlet: 40°C / 45°C, and outdoor ambient temp. 7°C DB/6°C WB.

Model			MCCH185A-SA3	MCCH250A-SA3T
Cooling Capacity	kW		185	250
	Btu/h		631,220	830,000
Heating Capacity		kW	200	270
Power supply		V/Ph/Hz	380-400/3/50	380-400/3/50
Power supply	Manual switch	A	400	450
	Fuse	A	300	350
Compressor	Type		Scroll (fixed speed)	Scroll (fixed speed)
	Quantity	Pieces	6	8
	Model		SH140A4ALC	SH120A4ALC
	Brand		Danfoss	Danfoss
	Capacity	W	34.7×6	111231
	Input	W	10860×6	10275
	Rate current(RLA)	A	21.4×6	20.88
	Locked rotor Amp(LRA)	A	147×6	177
Power input	Cooling	kW	63	78.3
	Cooling rated current	A	110	141.9
	Heating	kW	61	80
	Heating rated current	A	107	146
Max. Input consumption		kW	78.3	78.3
Max. Current		A	133.4	133.4
Refrigerant	Type		R410A	R410A
	Weight	Kg	7×6	15×4
	Refrigerant control		EXV+ capillary	EXV+ capillary
Condenser (Air side)	Air side heat-exchanger type		Fin-coil	Fin-coil
	Quantity of fan motor	Pieces	6	8
	Air flow	×10 ³ m ³ /h	72	96
	Fan motor input	kW	0.88×6	0.7×8
Evaporator (Water side)	Water side heat-exchanger type		Shell and tube	Shell and tube
	Water resistance loss	kPa	30	40
	Water inlet/outlet pipeline inside normal diameter	mm	DN80	DN100
		inch	3"	4"
	Water flow	m ³ /h	31.8	43
	Max. Pressure	MPa	1	1
	Water pipe connection type		Flexible joint	Flexible joint
Dimension	Net(W×H×D)	mm	2850×2110×2000	3800×2130×2000
		inch	112.2×83.1×78.7	149.6×83.86×78.74
	Packing(W×H×D)	mm	2980×2260×2135	3900×2200×2100
		inch	117.3×89×84.1	153.54×86.61×82.68
Weight	Net weight	kg	1730	2450
	Operation weight	kg	2000	2600
Connection wire	Power wire	mm ² ×No.	75×3+35×2	185×4+70×1
	Signal wire	mm ² ×No.	0.75×3-core with shielding	0.75×3-core with shielding
Control type			Wired controller	Wired controller

Safety protection device		1) Protection for over-high discharge pressure. 2) Protection for over-low suction pressure. 3) Power supply phase sequence protection. 4) Anti-freezing protection in cooling mode. 5) Anti-freezing protection in Winter. 6) Protection for compressor over current. 7) Protection for compressor overload. 8) Outlet and inlet water temperature difference protection. 9) Compressor discharge temperature protection. 10) Water flow cut-off protection. 11) Sensor malfunction protection. 12) Low temperature protection of shell and tube heat exchanger.	1) Protection for over-high discharge pressure. 2) Protection for over-low suction pressure. 3) Power supply phase sequence protection. 4) Anti-freezing protection in cooling mode. 5) Anti-freezing protection in Winter. 6) Protection for compressor over current. 7) Protection for compressor overload. 8) Outlet and inlet water temperature difference protection. 9) Compressor discharge temperature protection. 10) Water flow cut-off protection. 11) Sensor malfunction protection. 12) Low ambient temperature drive-up protection 13) Low temperature protection of shell and tube heat exchanger.
Noise level(semi-anechoic)	dB(A)	70	74
Operation water temp	°C	Cooling: 5~17 Heating: 45~50	Cooling: 0~17(Less than 5°C must add antifreeze) Heating: 22~50
Ambient temp	°C	Cooling: 10~46 Heating: -10~21	Cooling: 10~52 Heating: -10~21

Note:

Please refer to the water flow volume in the above table strictly to design and install.

All the above data is measured base on the following working condition:

1. Cooling mode: water side fouling factor: $0.086\text{m}^2 \cdot ^\circ\text{C}/\text{kW}$, chilled water inlet/outlet: $12^\circ\text{C} / 7^\circ\text{C}$, and outdoor ambient temp. of 35°C DB.

2. Heating mode: water side fouling factor: $0.086\text{m}^2 \cdot ^\circ\text{C}/\text{kW}$, warm water inlet/outlet: $40^\circ\text{C} / 45^\circ\text{C}$, and outdoor ambient temp. 7°C DB/ 6°C WB.

4 Dimension

30kW module

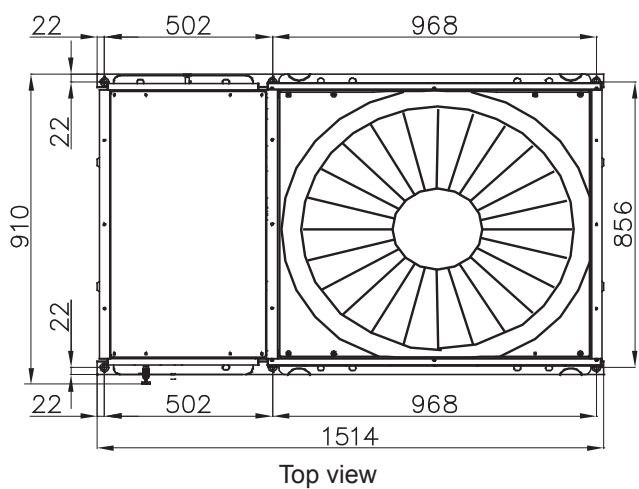
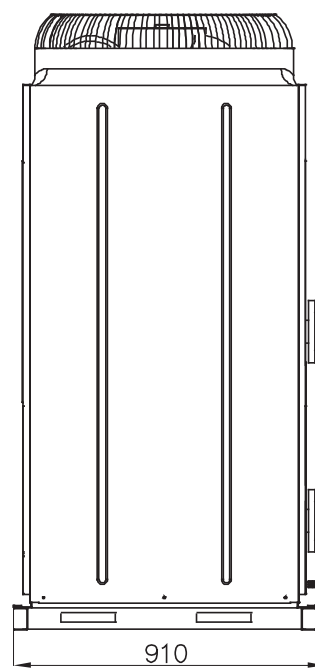
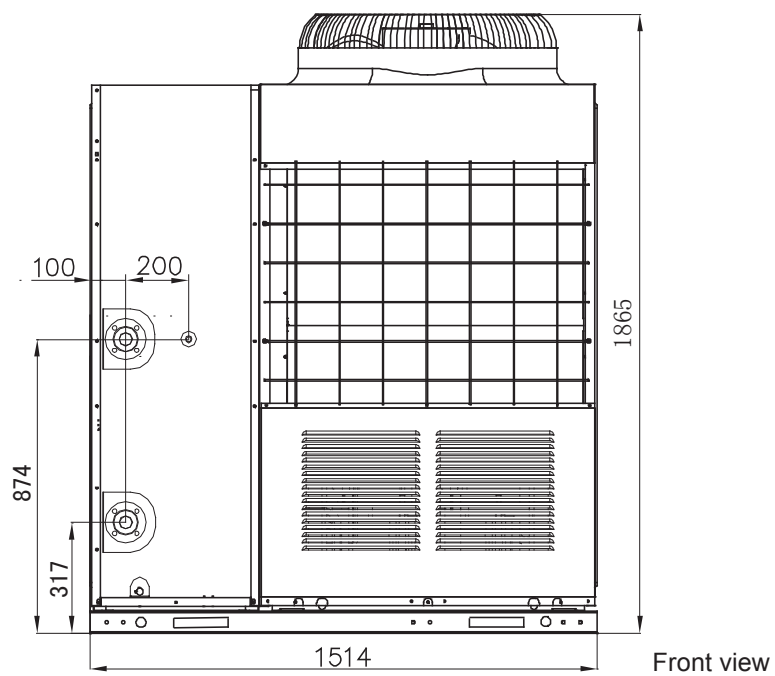

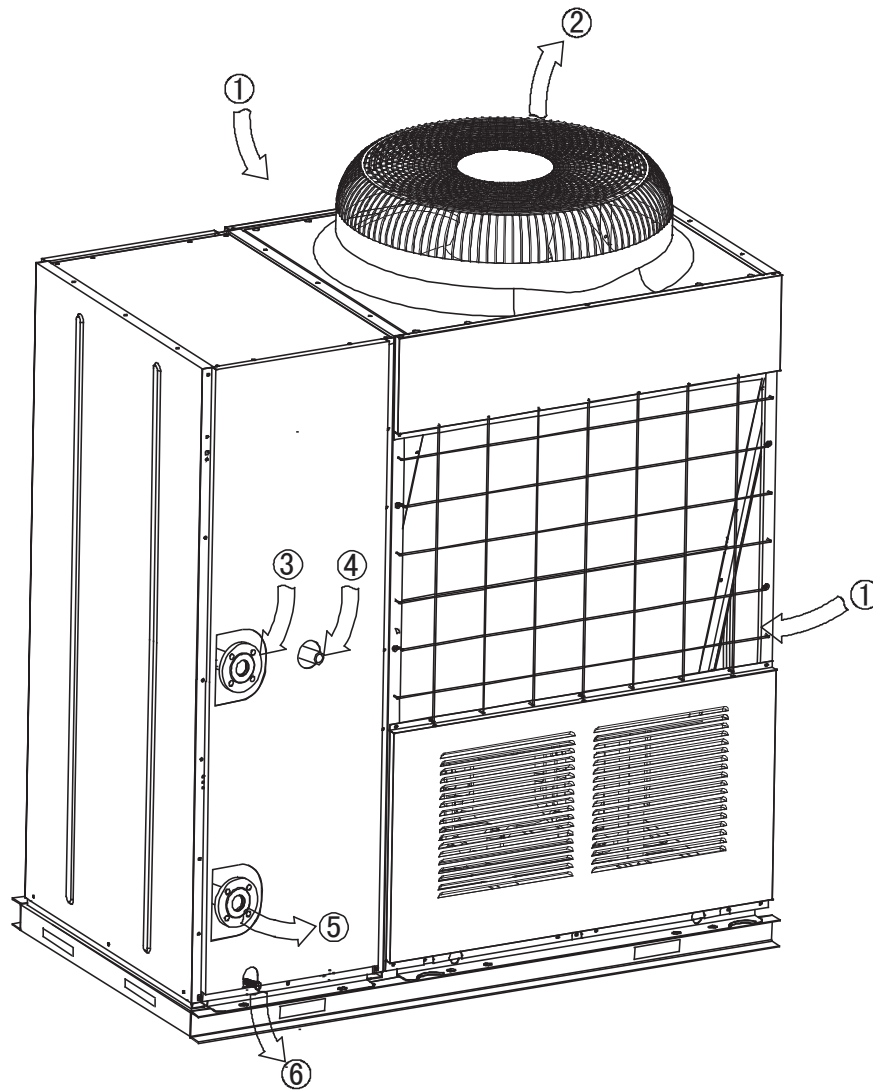

NO.	1	2	3	4	5	6
NAME	Air inlet	Air outlet	Water inlet	Make-up water inlet	Water outlet	Drain

65kW module

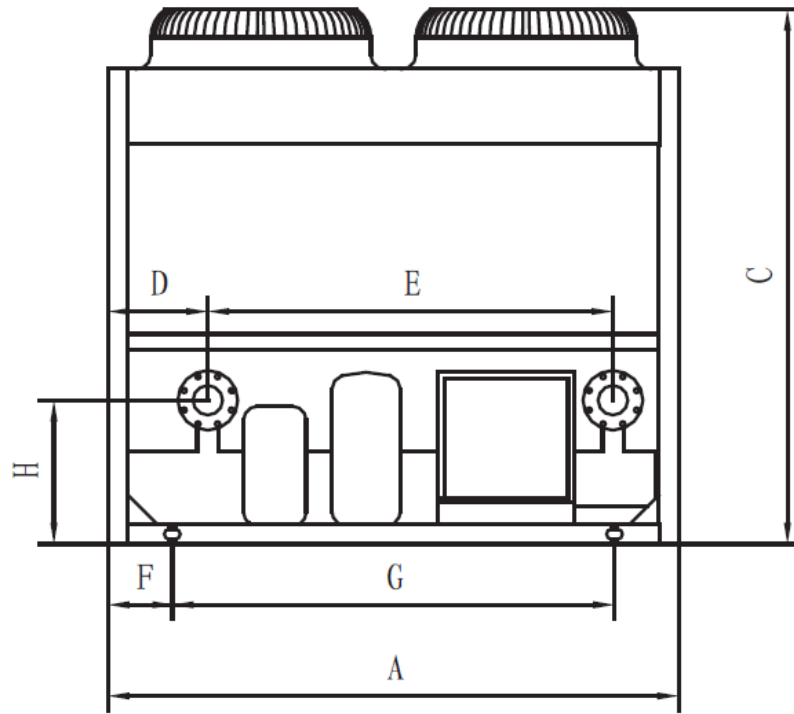

Front view

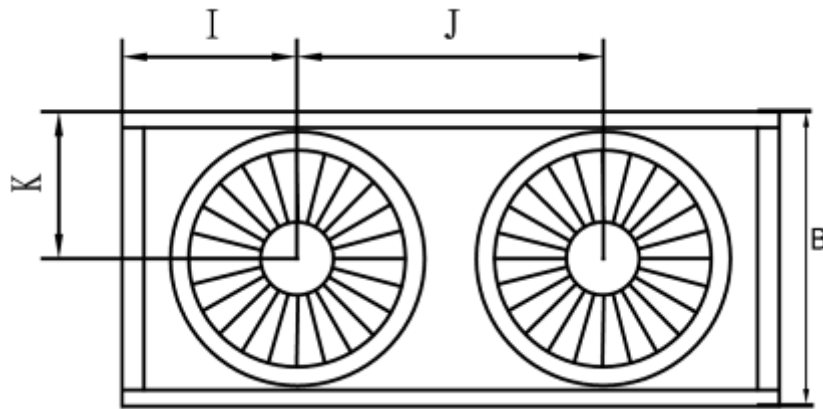

Top view

Model	Unit	A	B	C	D	E	F	G	H	I	J	K
MCC(D)H65A-SA3L	mm	2000	900	1880	350	1420	225	1500	506	530	930	450
	inch	78.74	35.4	74	13.78	55.91	8.86	59.06	19.92	20.87	36.61	17.72

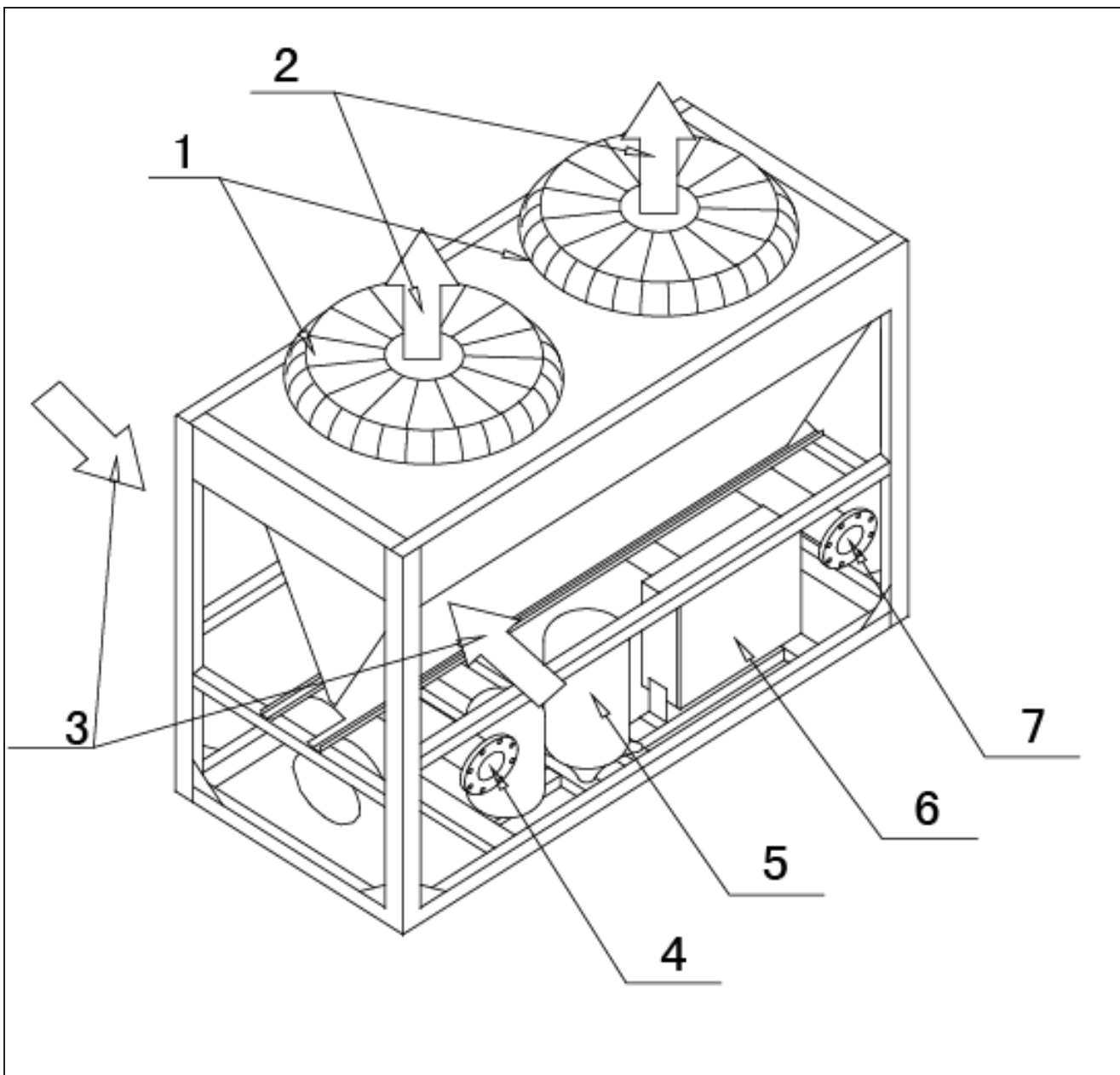

No.	Name
1	Top cover
2	Air outlet
3	Air inlet
4	Water outlet
5	Compressor
6	Electric control box
7	Water inlet

130kW module

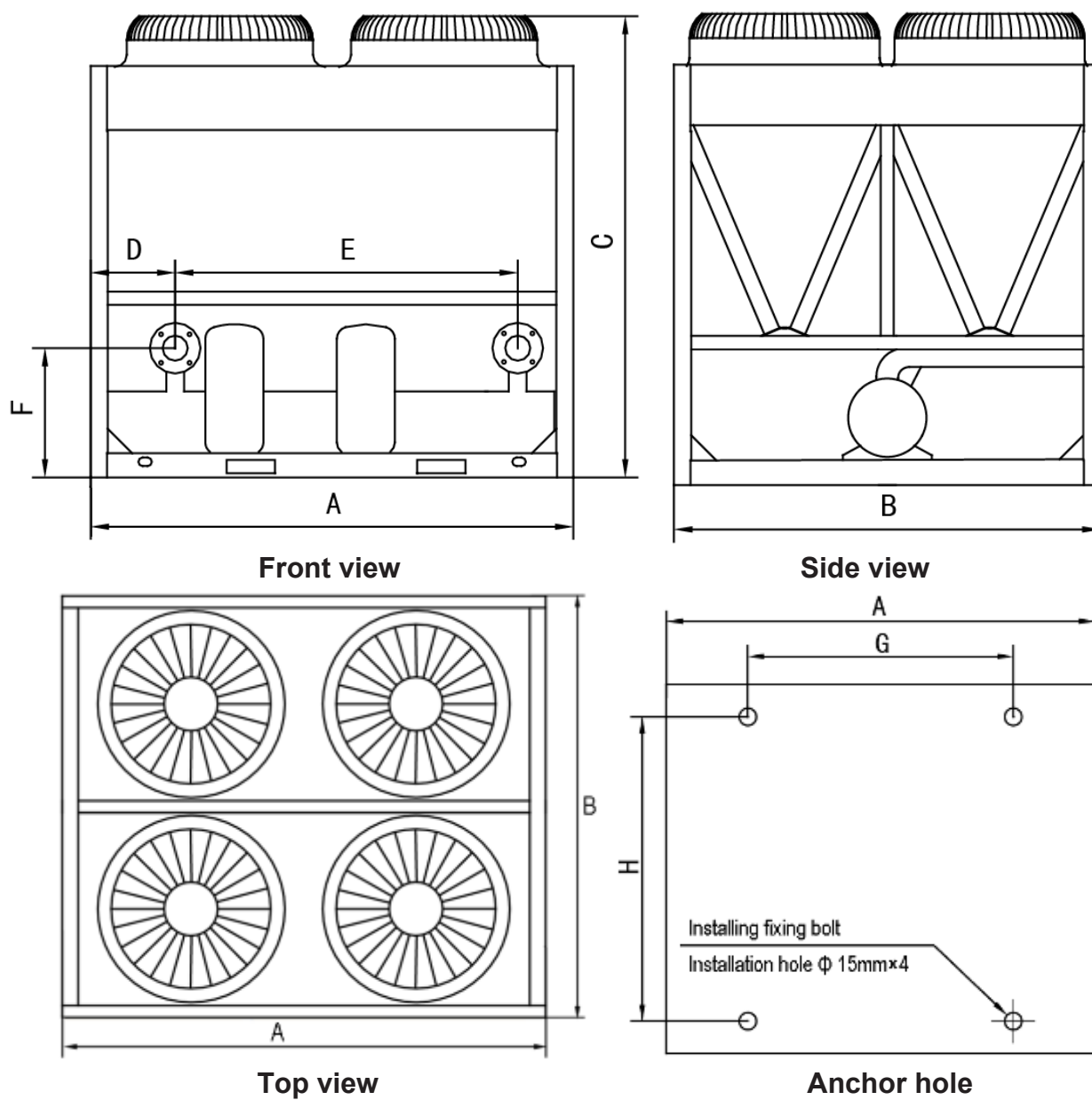

Model	Unit	A	B	C	D	E	F	G	H
MCCH130A-SA3L	mm	2000	1685	2080	350	1420	506	1550	1586
	inch	78.74	66.34	81.89	13.78	55.91	19.92	61.02	62.44

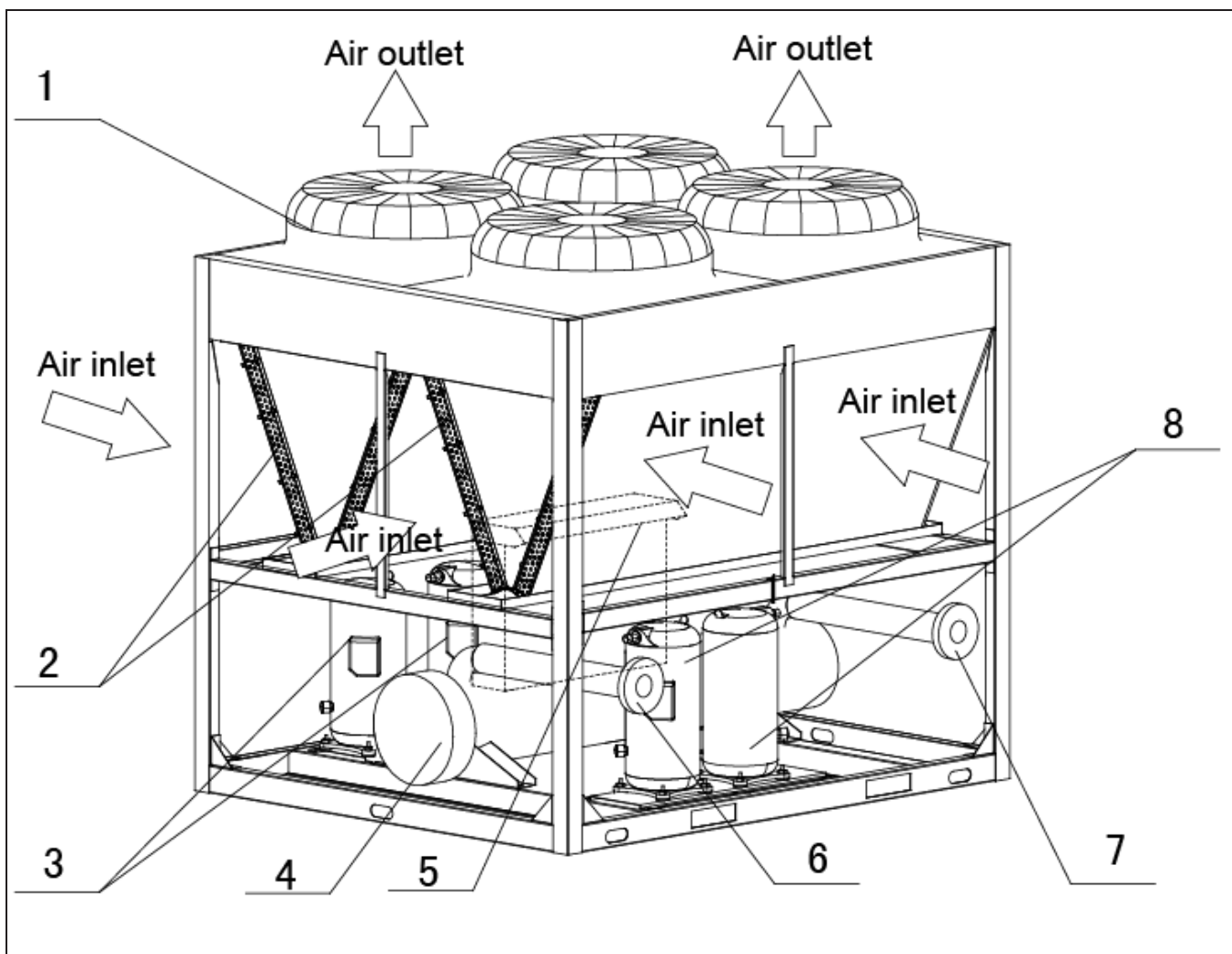

No.	Name
1	Top cover
2	Condenser
3	Compressor
4	Evaporator
5	Electric control box Air inlet
6	Water outlet
7	Water inlet
8	Compressor

185 kW module

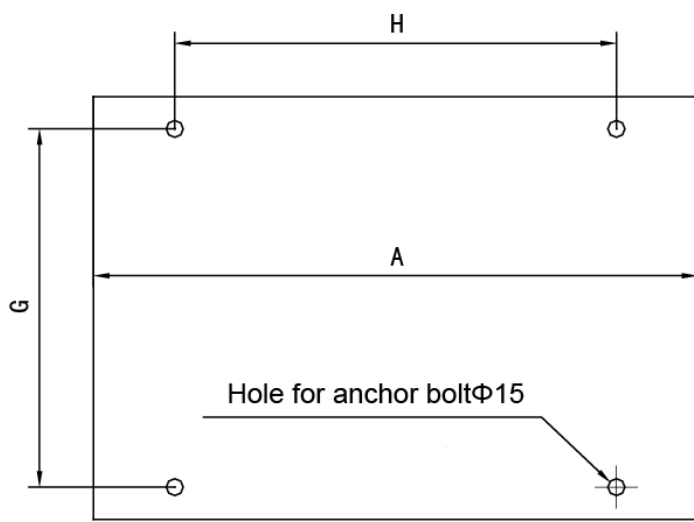
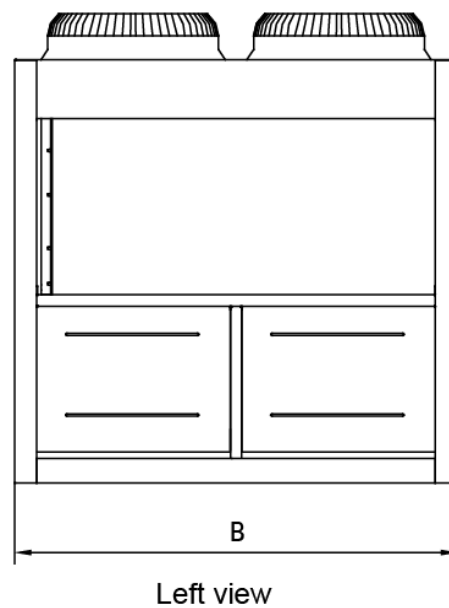
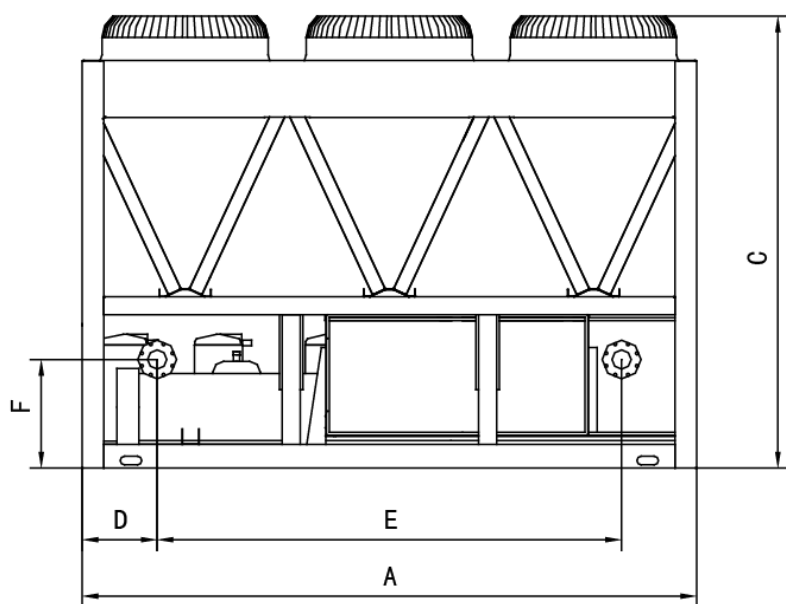

Bottom view

Model	unit	A	B	C	D	E	F	G	H
MCCH185A-SA3	Mm	2850	2000	2110	3470	2156	506	1888	2388
	inch	112.2	78.74	83.07	136.61	84.88	19.92	74.33	94.02

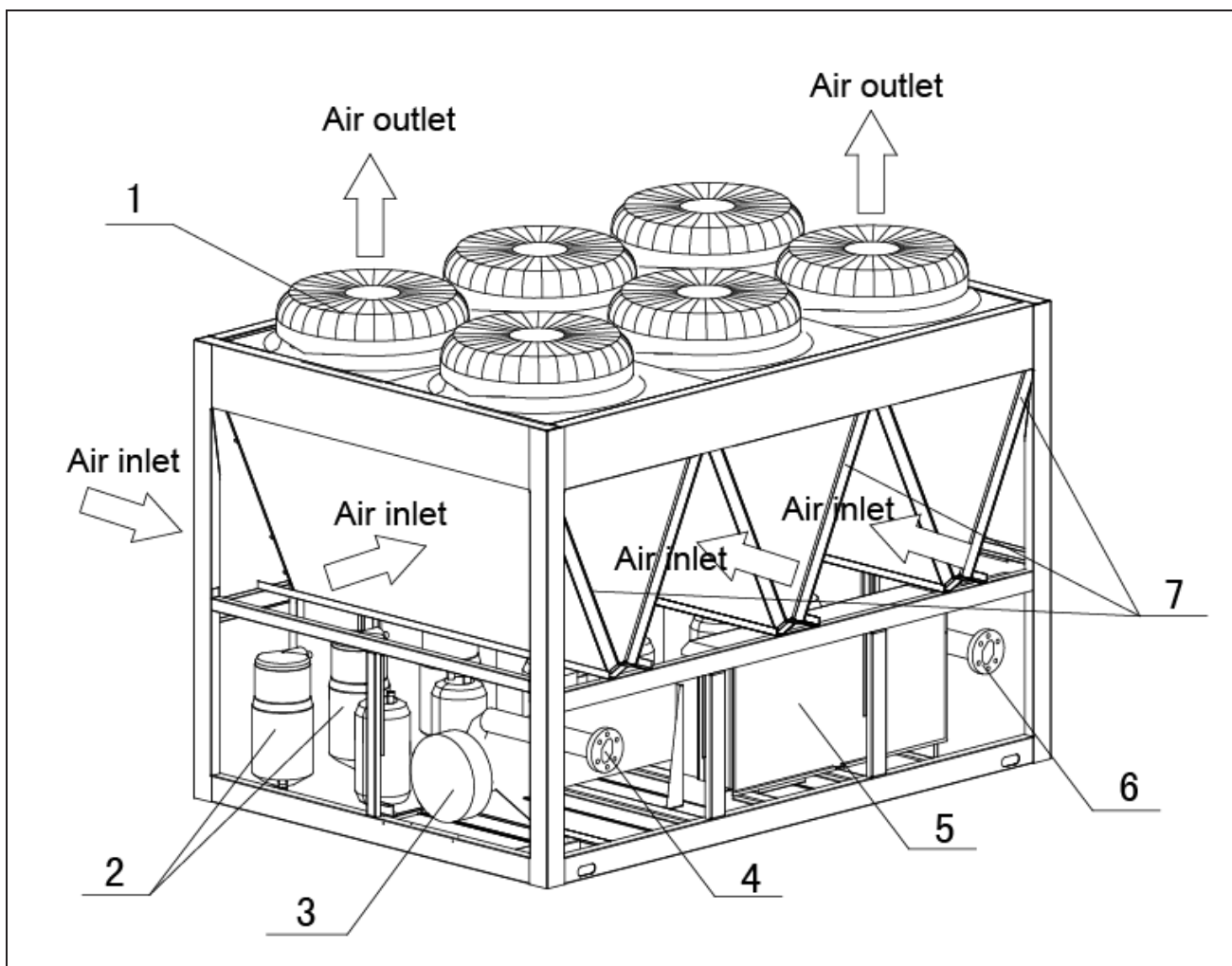

No.	Name
1	Top cover
2	Compressor
3	Evaporator
4	Water outlet
5	Electric control box
6	Water inlet
7	Condenser

250kW module

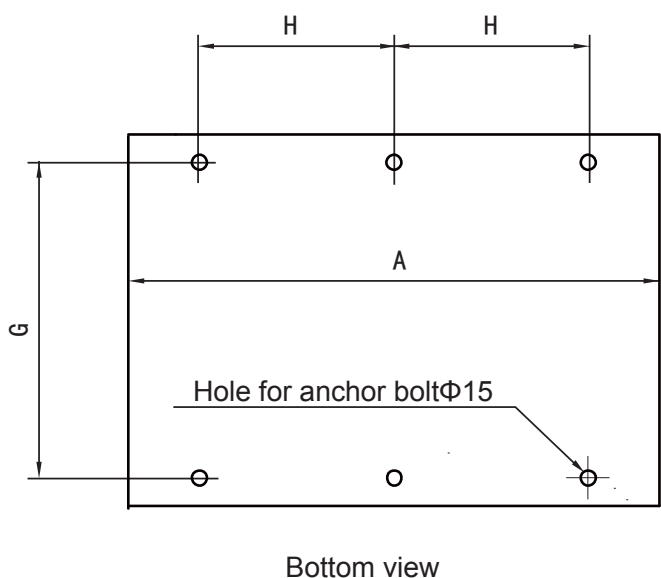
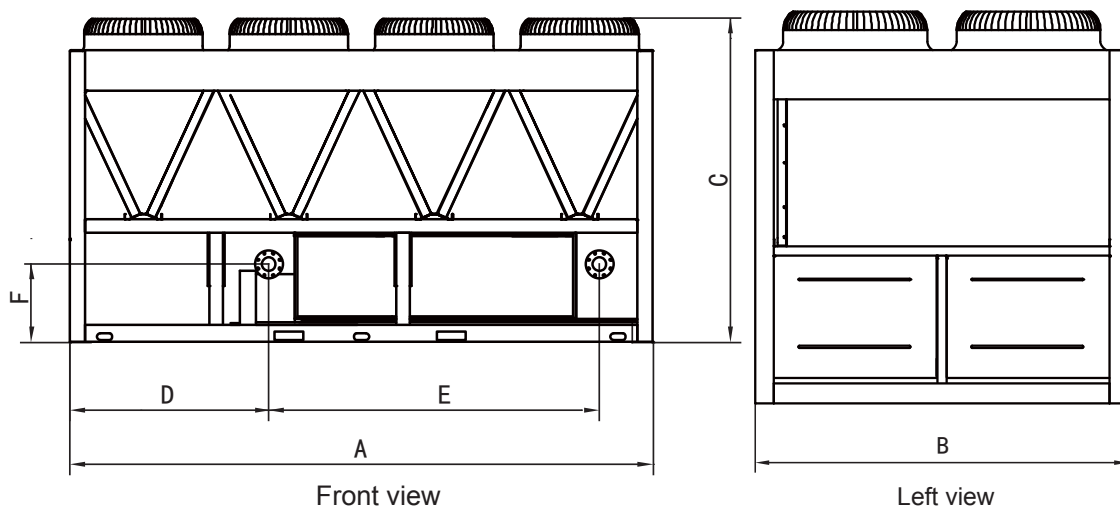

Model	unit	A	B	C	D	E	F	G	H
MCCH250A-SA3T	Mm	3800	2000	2130	1235	2156	573	1888	1551
	inch	149.6	78.74	83.86	48.62	84.88	22.56	74.33	61.06

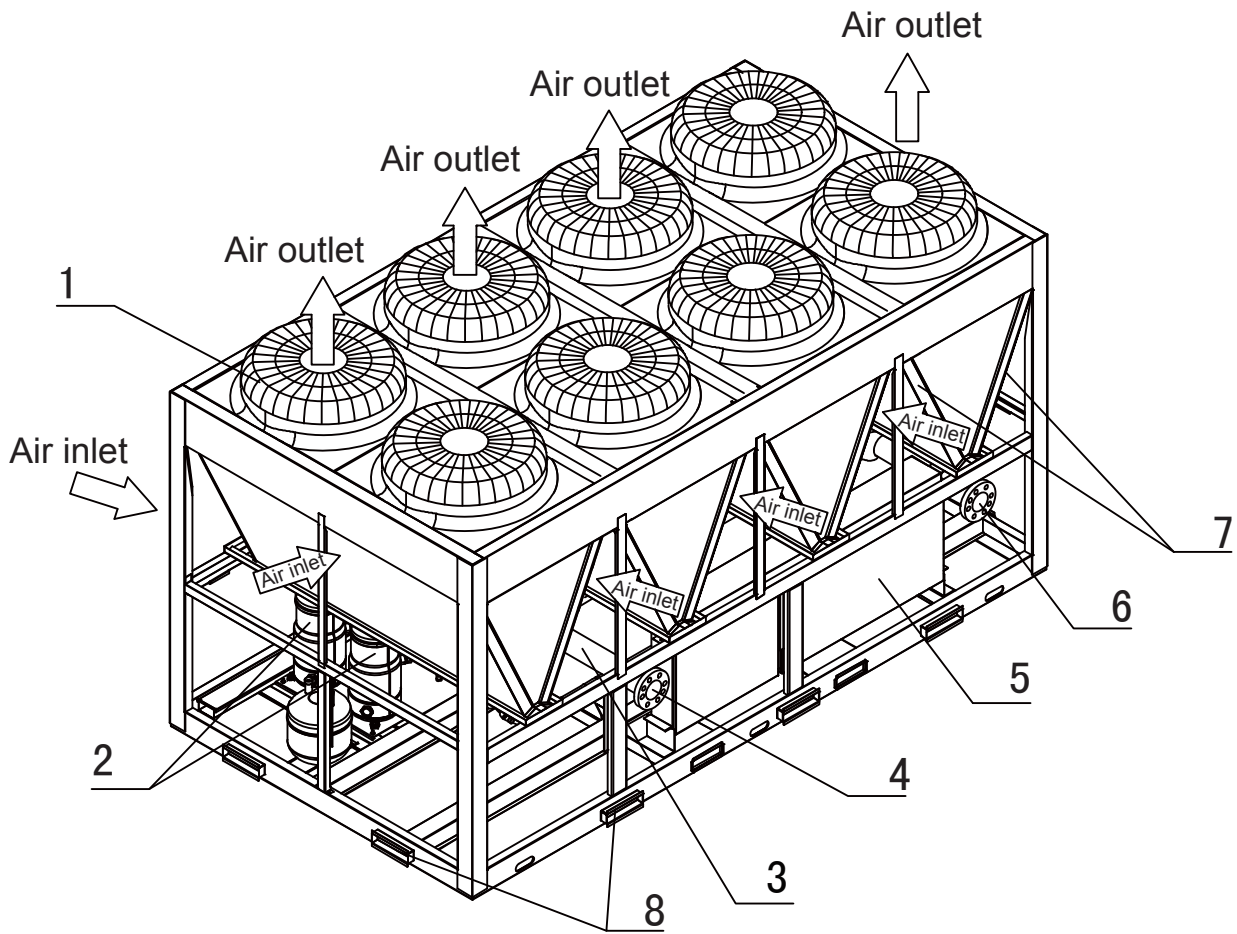

No.	Name
1	Top cover
2	Compressor
3	Evaporator
4	Water outlet
5	Electric control box
6	Water inlet
7	Condenser
8	Transportation guard plate (Be removed off after installation)

5 Refrigeration system drawing

5.1 30kW module refrigeration system sketch drawing

Each module has two compressors with one separate unit, one double-pipe evaporator for two refrigerant systems.

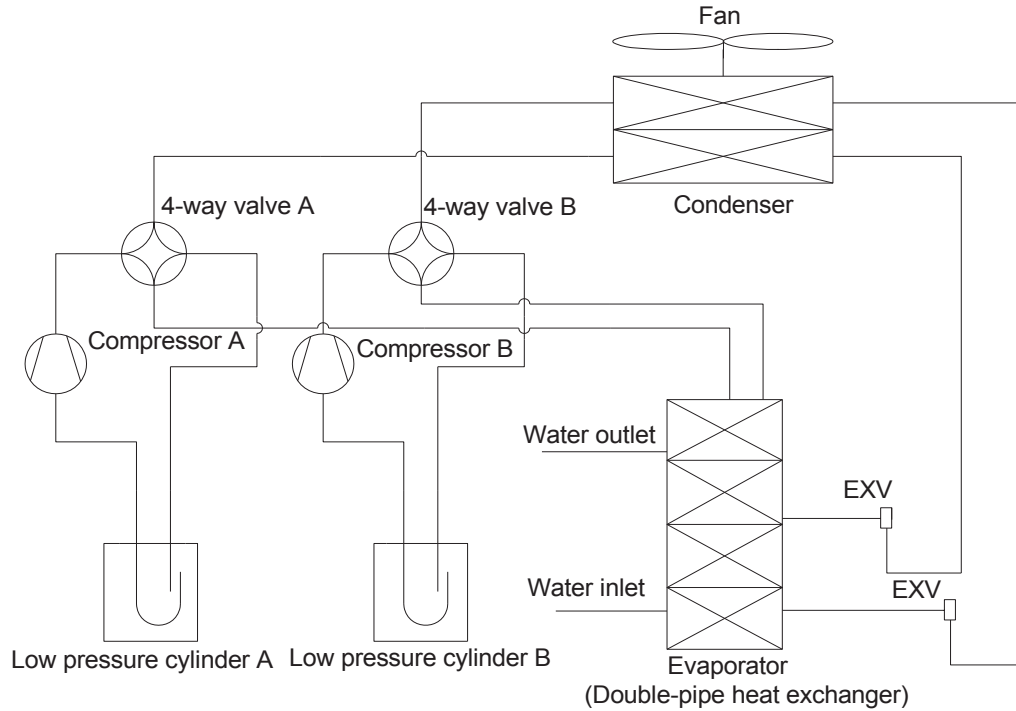

5.2 65kW module refrigeration system sketch drawing(Fixed speed)

Each module has two compressors with one separate unit, one shell and tube evaporator for two refrigerant systems.

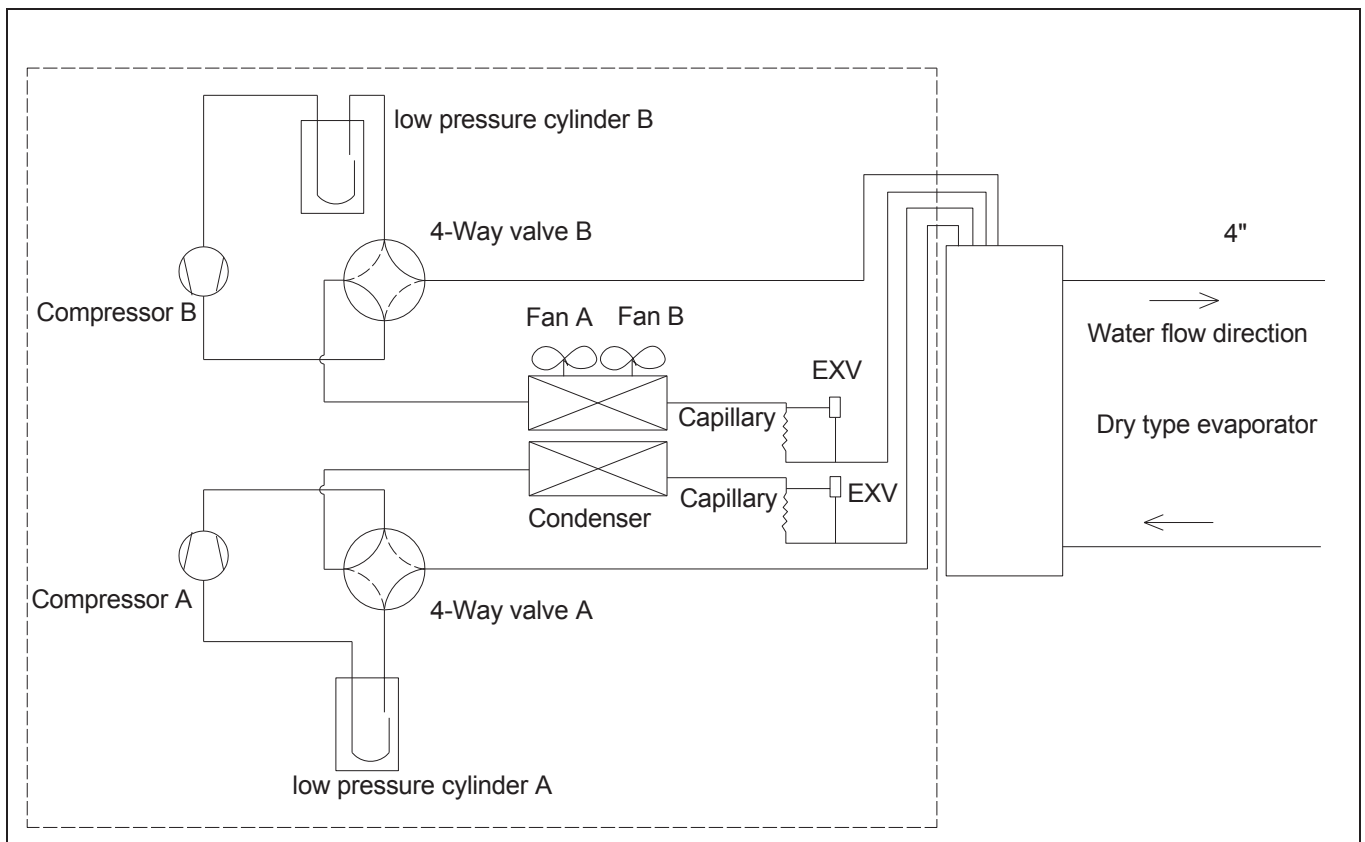

65kW digital module (MCCD65A-SA3L)

Each module has three compressors with one separate unit, one shell and tube evaporator for two refrigerant systems.

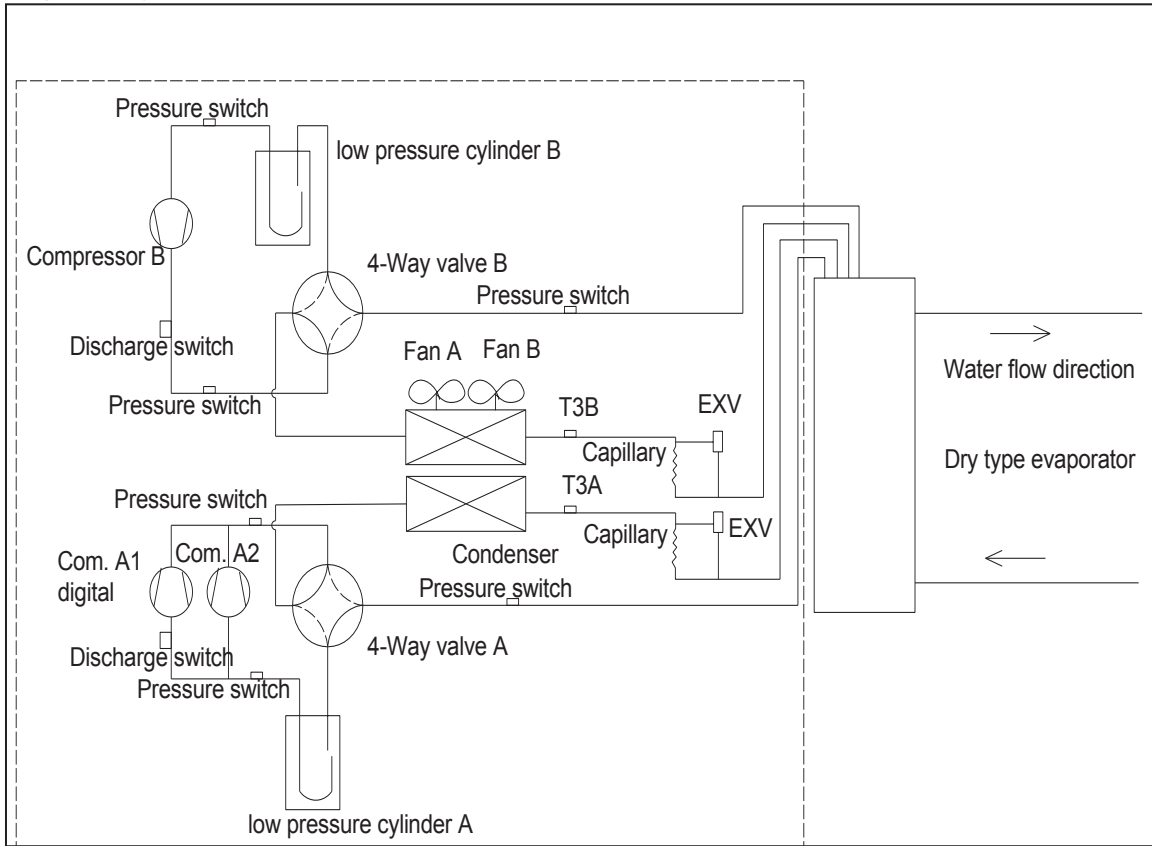

5.3 130kW module refrigeration system sketch drawing

Each module has four compressors with two separate units, one shell and tube evaporator for four refrigerant systems.

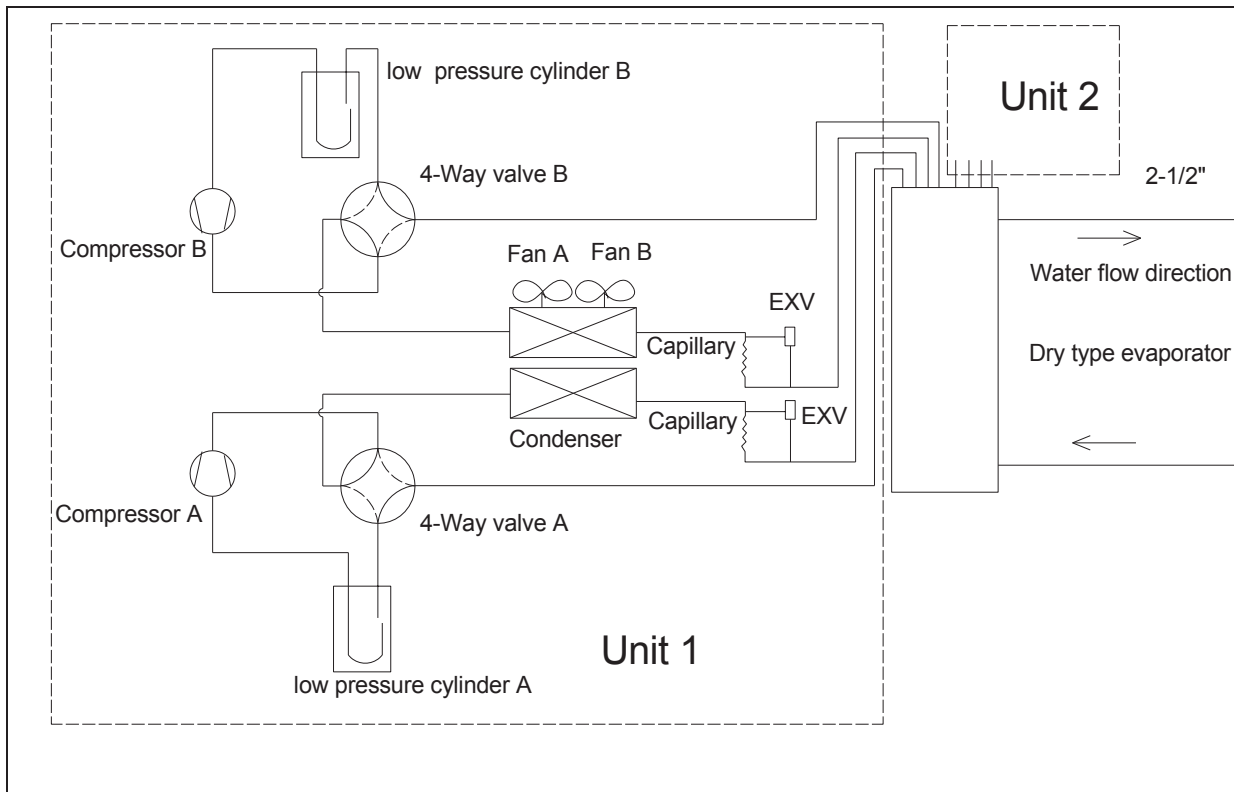

5.4 185 kW module refrigeration system sketch drawing

Each module has six compressors with three separate units, one shell and tube evaporator for six refrigerant systems.

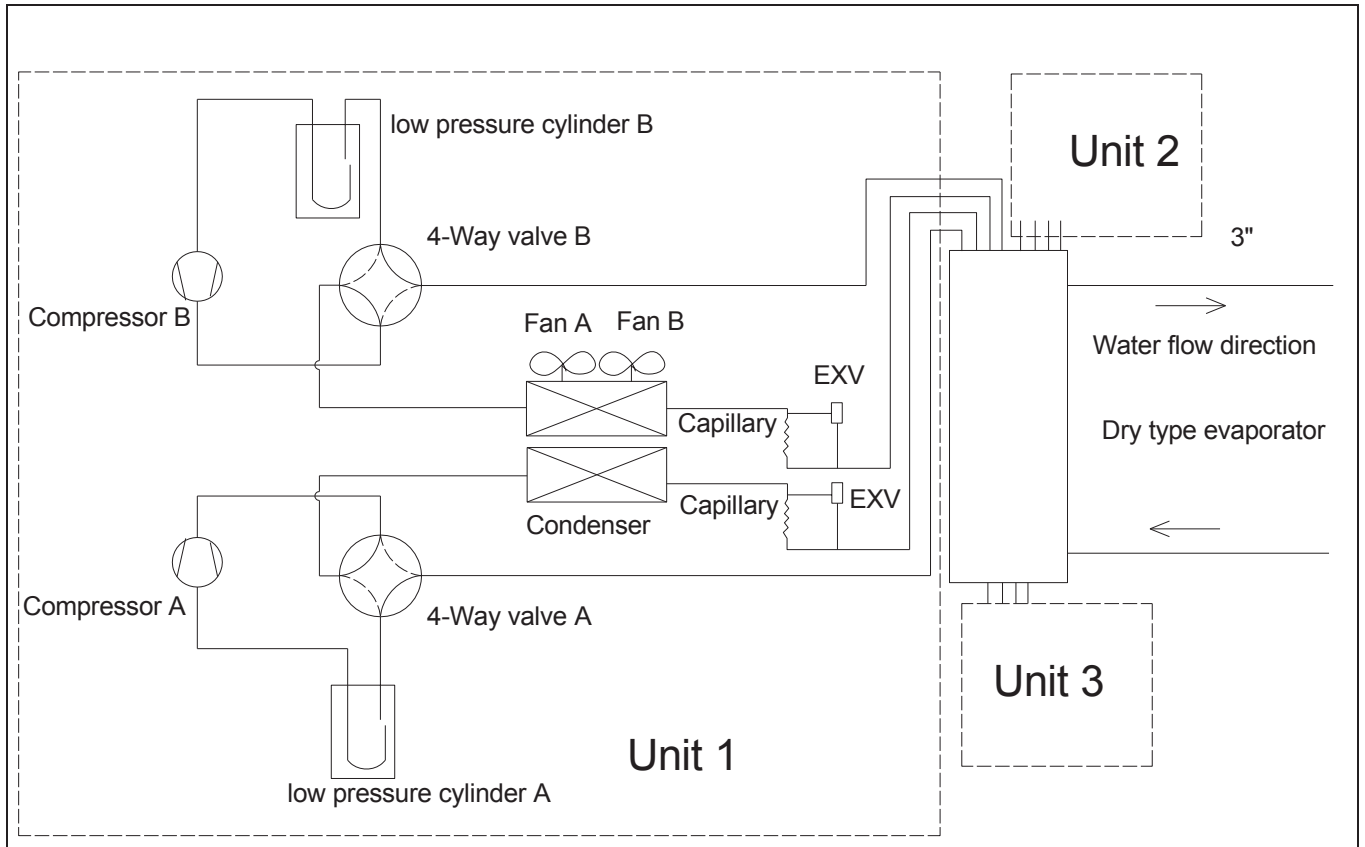

5.5 250kW module refrigeration system sketch drawing

Each module has eight compressors with two separate units, one shell and tube evaporator for four refrigerant systems.

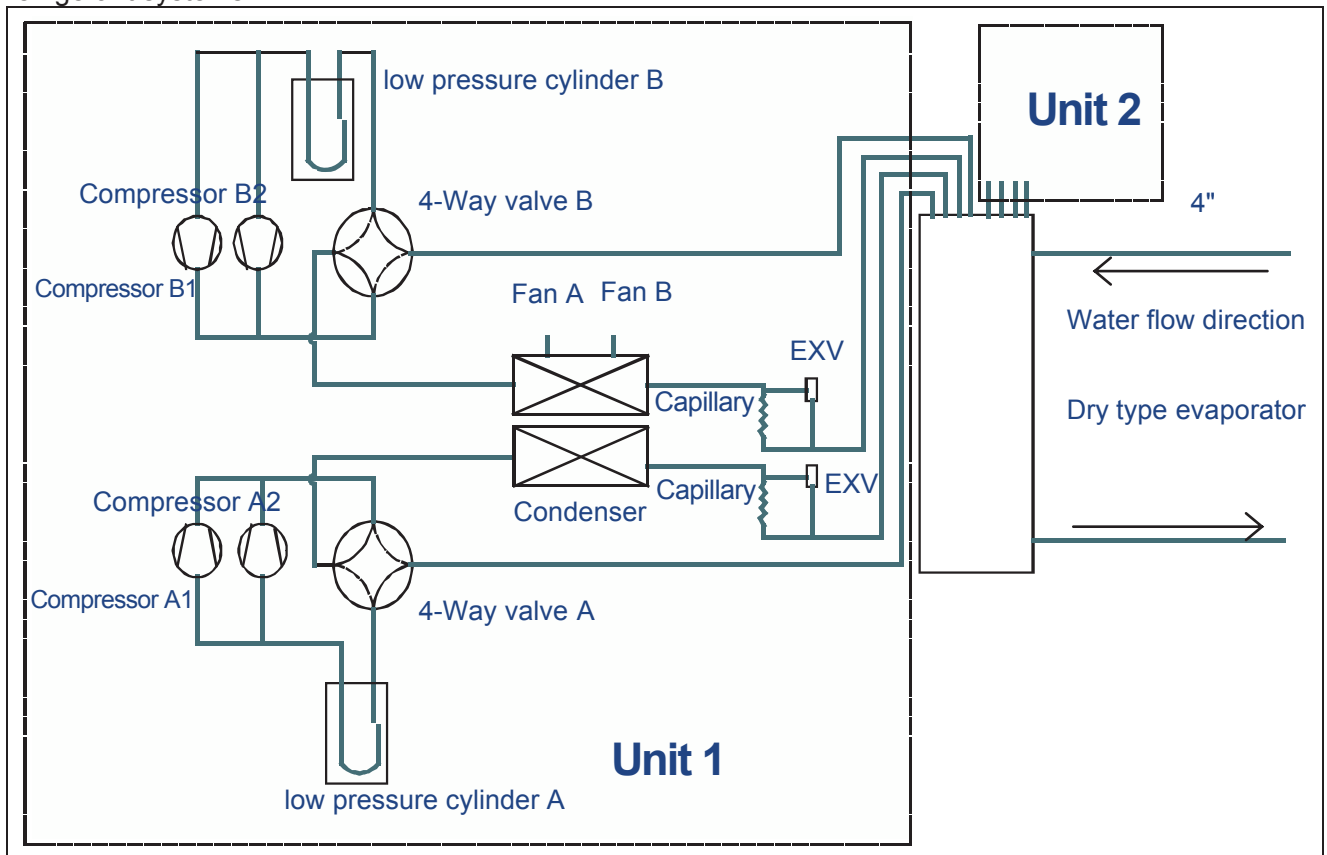

6. Piping diagram

6.1 30kW module water pipeline sketch drawing

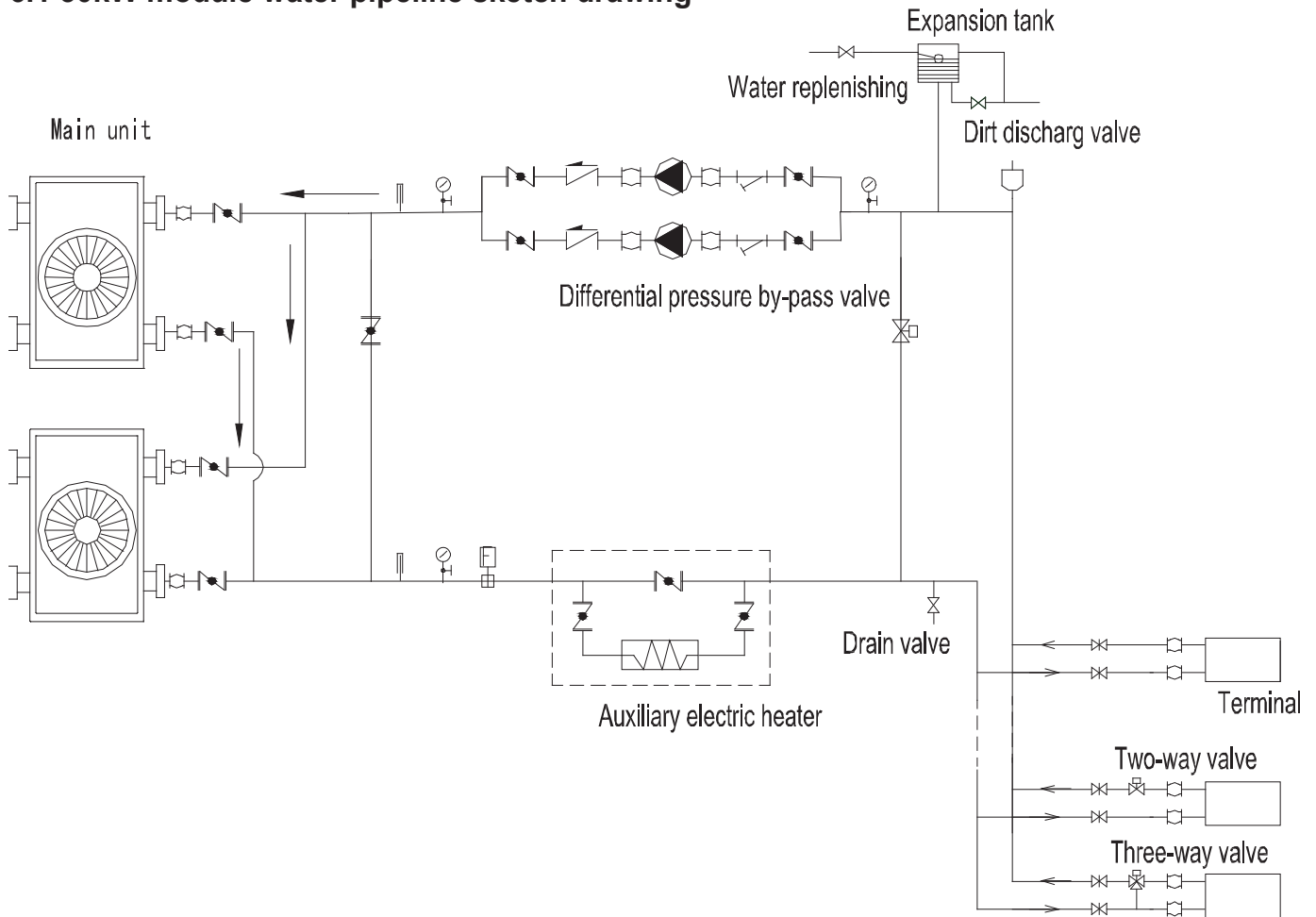

The table below describes the symbols.

Symbol	Symbol explanation	Symbol	Symbol explanation
	Stop valve		Y-shaped filter
	Pressure gauge		Thermometer
	Water flow switch		Circulating pump
	Gate valve		Check valve
	Flexible joint		Automatic discharge valve

30kW module water pipeline sketch drawing

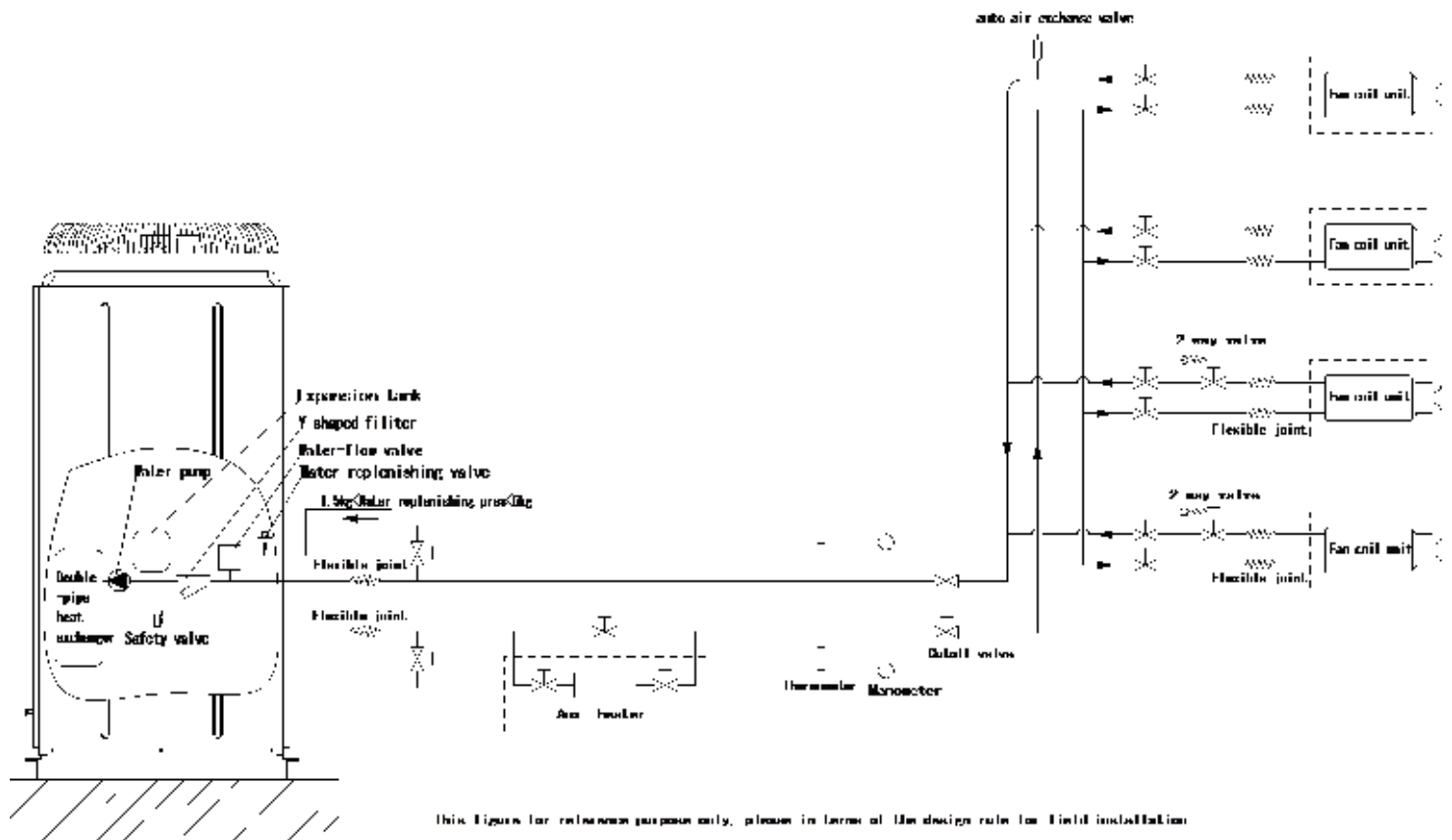

The table below describes the symbols.

Symbol	Symbol explanation	Symbol	Symbol explanation
	Safety valve		Y-shaped filter
	Pressure gauge		Thermometer
	Water flow switch		Water pump
	Cut off valve		Expansion tank
	Manometer		Water replenishing valve

6.2 65kW module water pipeline sketch drawing

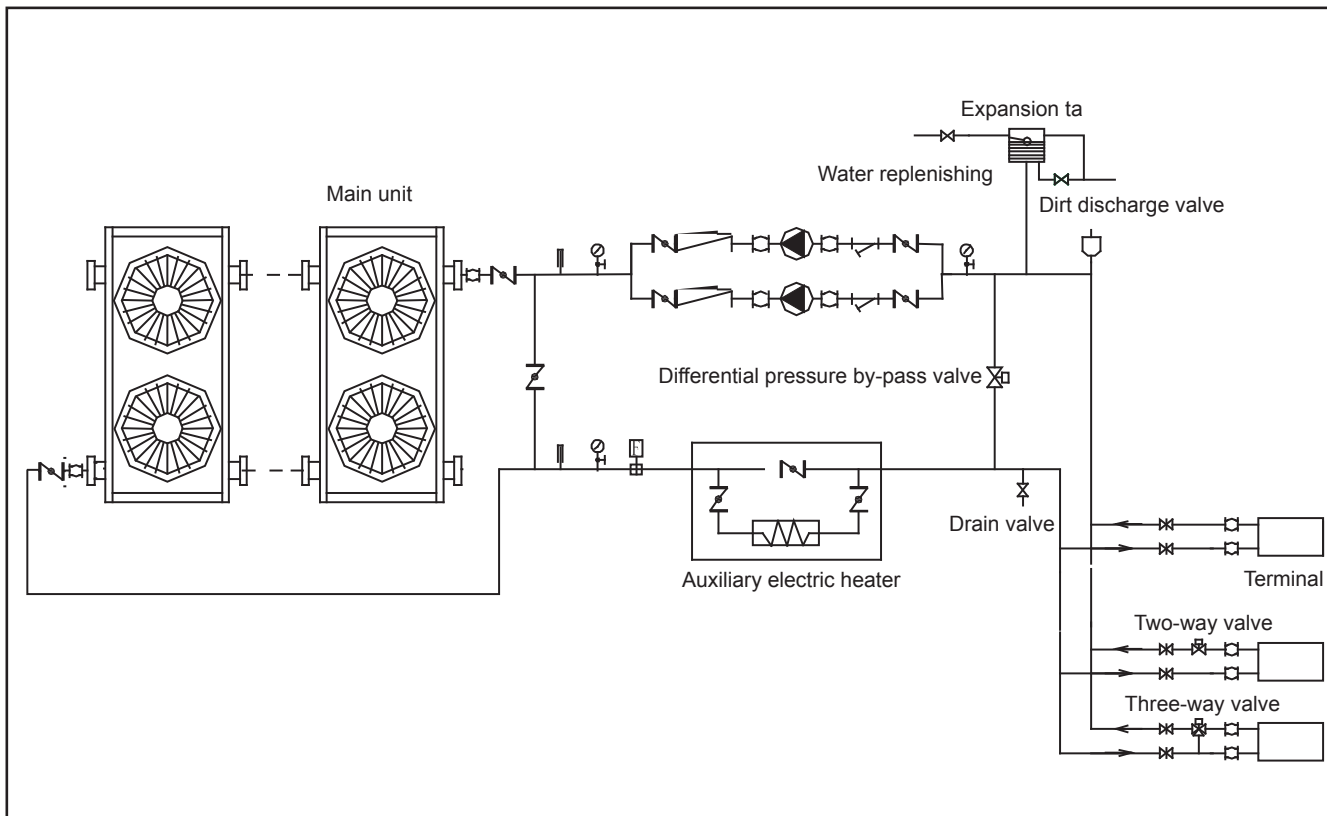

The table below describes the symbols.

Symbol	Symbol explanation	Symbol	Symbol explanation
	Stop valve		Y-shaped filter
	Pressure gauge		Thermometer
	Water flow switch		Circulating pump
	Gate valve		Check valve
	Flexible joint		Automatic discharge valve

6.3 130kW module water pipeline sketch drawing

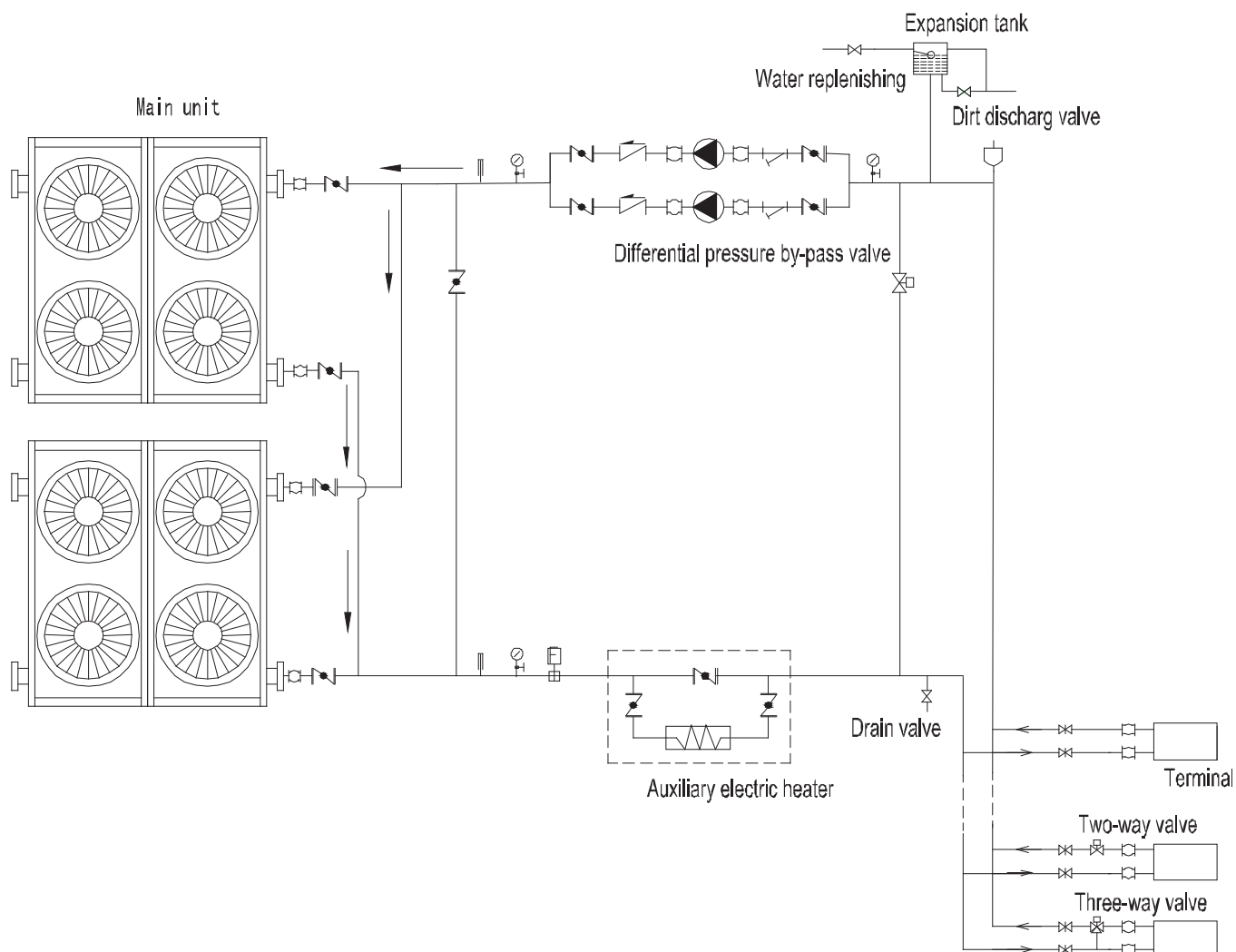

The table below describes the symbols.

Symbol	Symbol explanation	Symbol	Symbol explanation
	Stop valve		Y-shaped filter
	Pressure gauge		Thermometer
	Water flow switch		Circulating pump
	Gate valve		Check valve
	Flexible joint		Automatic discharge valve

6.4 185 kW module water pipeline sketch drawing

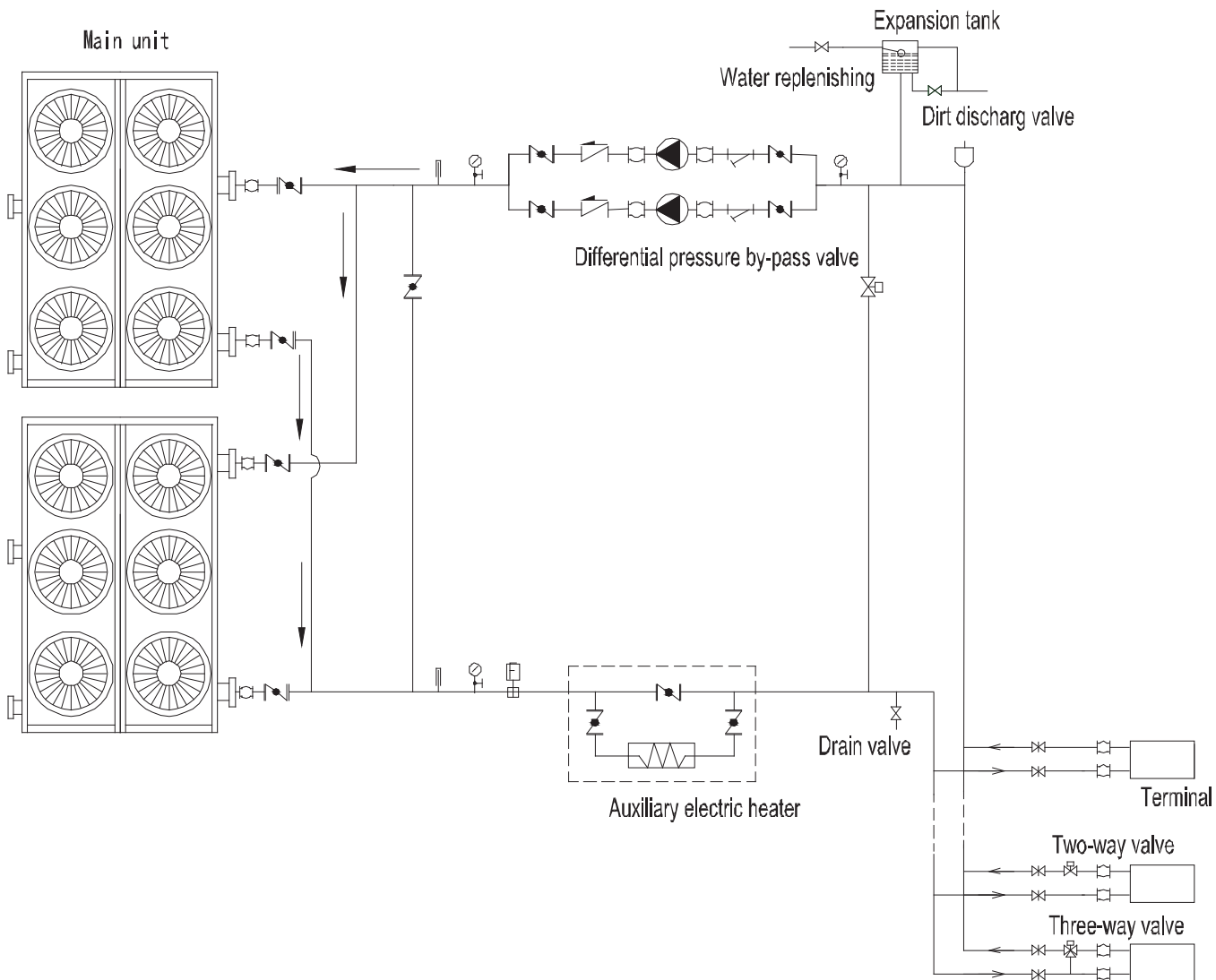

The table below describes the symbols.

Symbol	Symbol explanation	Symbol	Symbol explanation
	Stop valve		Y-shaped filter
	Pressure gauge		Thermometer
	Water flow switch		Circulating pump
	Gate valve		Check valve
	Flexible joint		Automatic discharge valve

6.5 250kW module water pipeline sketch drawing

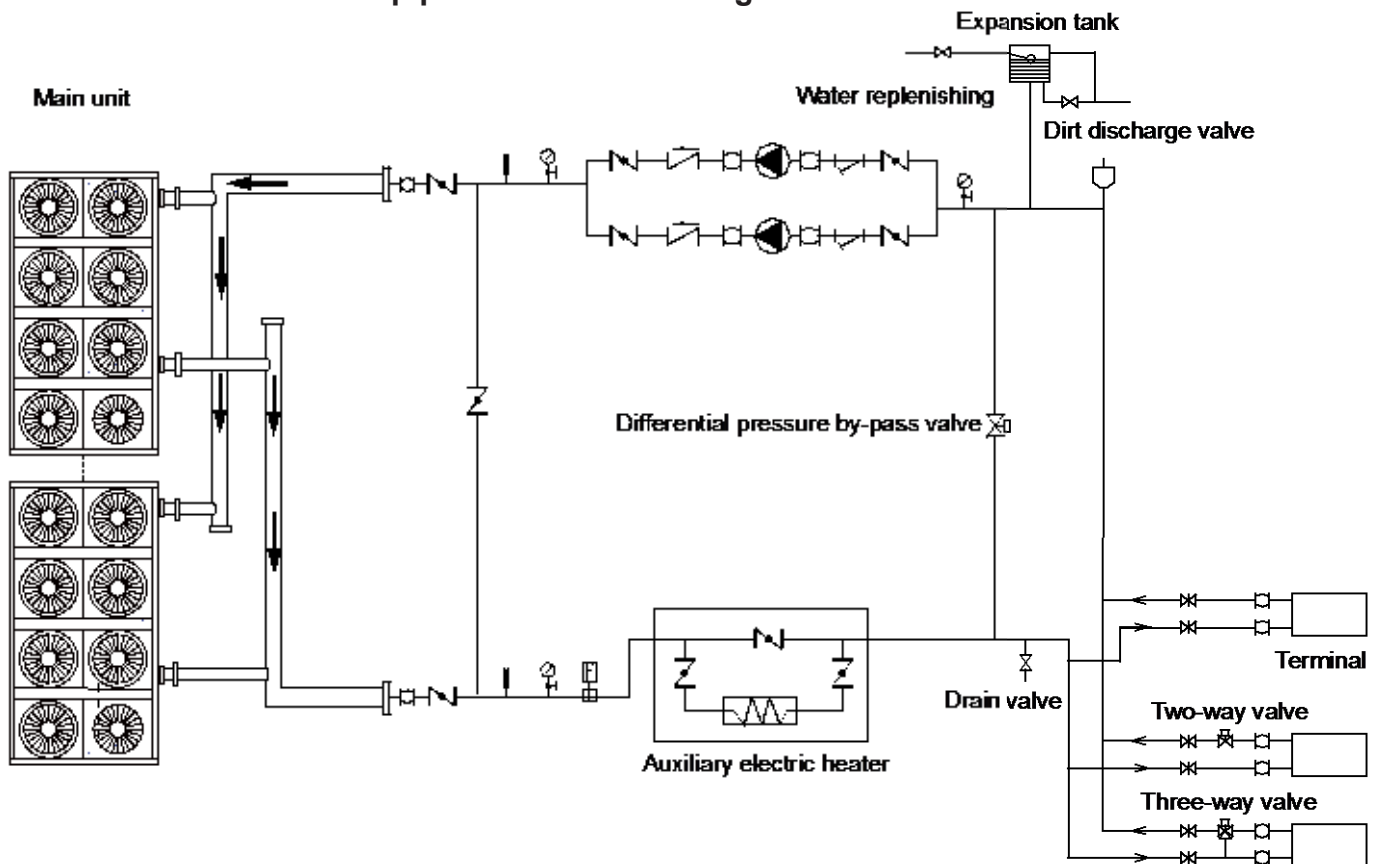

The table below describes the symbols.

Symbol	Symbol explanation	Symbol	Symbol explanation
	Stop valve		Y-shaped filter
	Pressure gauge		Thermometer
	Water flow switch		Circulating pump
	Gate valve		Check valve
	Flexible joint		Automatic discharge valve

7 Wire Diagrams

7.1 Wiring diagrams

30kW module (Only for MCCH30A-TA3SL, MCDH30A-TA3SL)

Attached picture (I) Electric Drawing of Main Unit and Auxiliary Unit

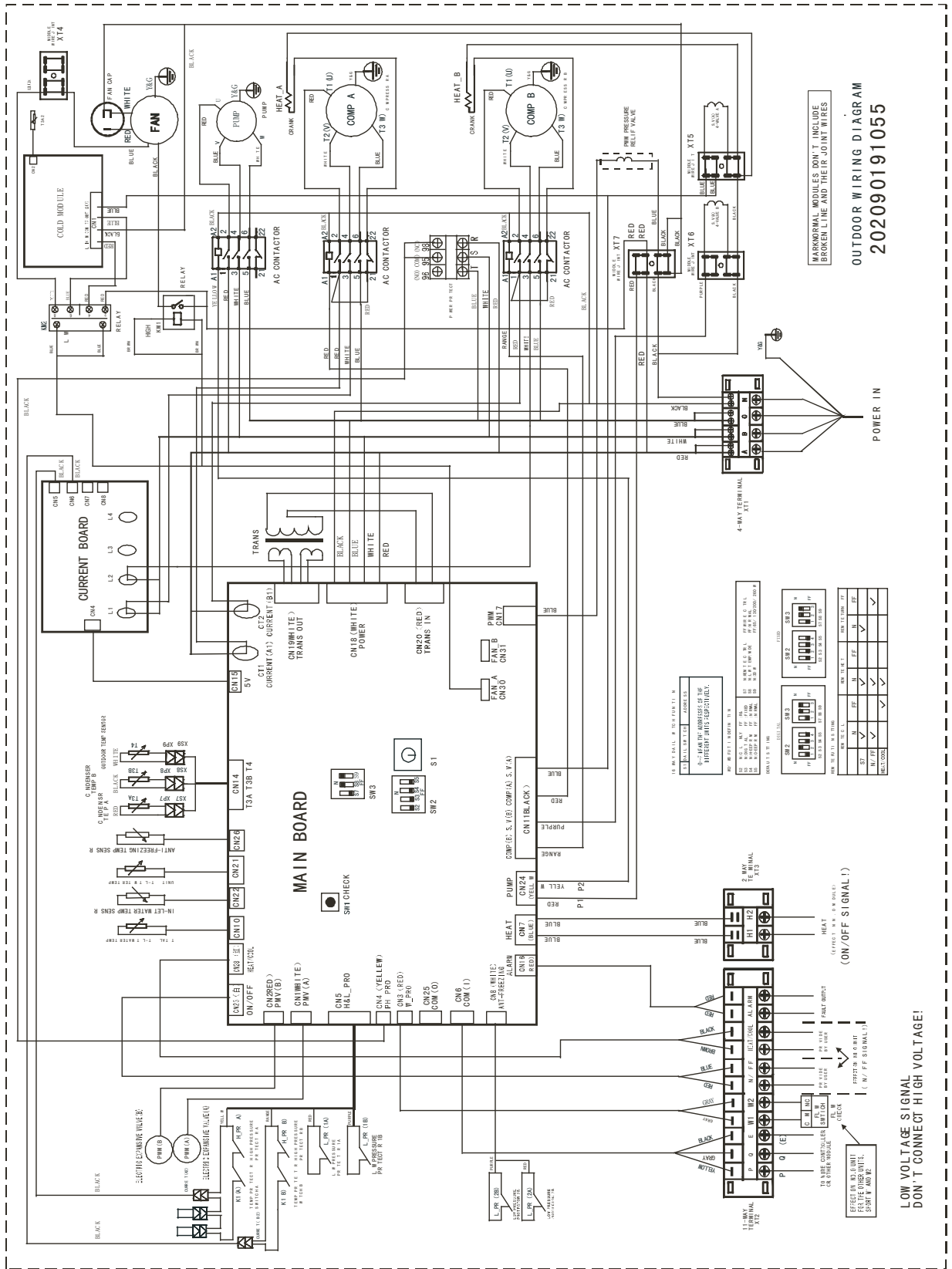

MCCH65A-SA3L

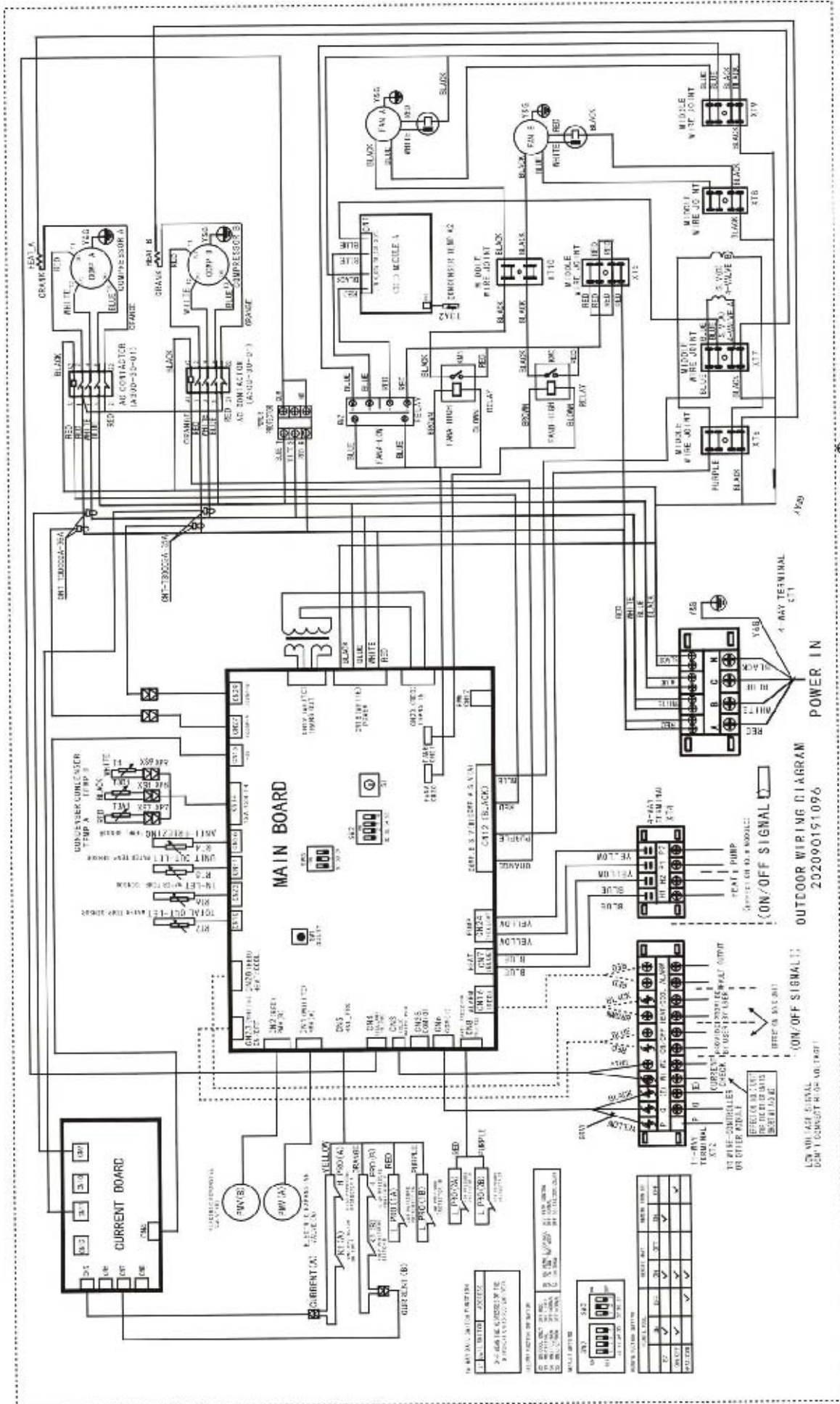

MCCD65A-SA3L

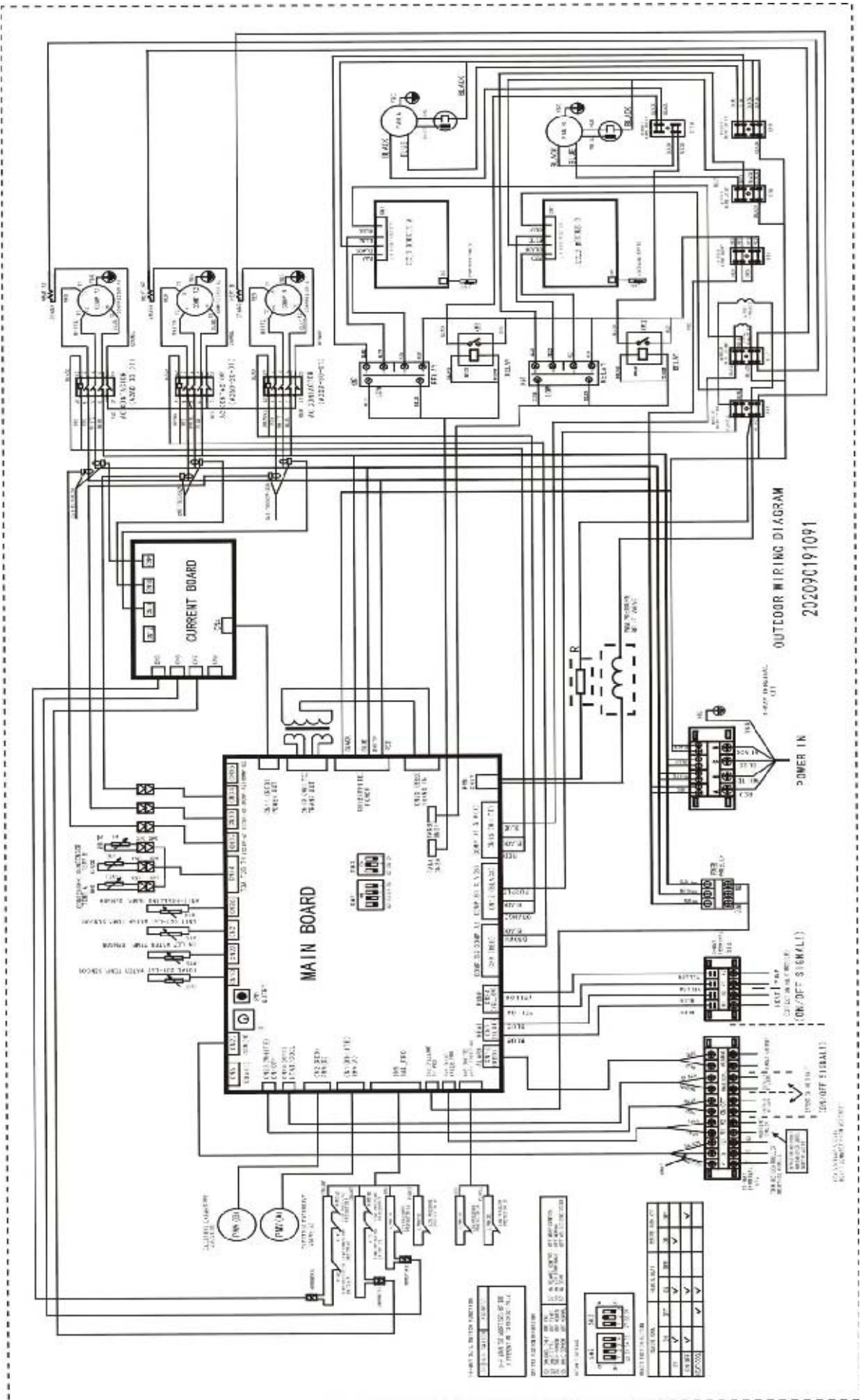

130kW module

Attached picture (1) Electric Drawing of Main Unit and Auxiliary Unit

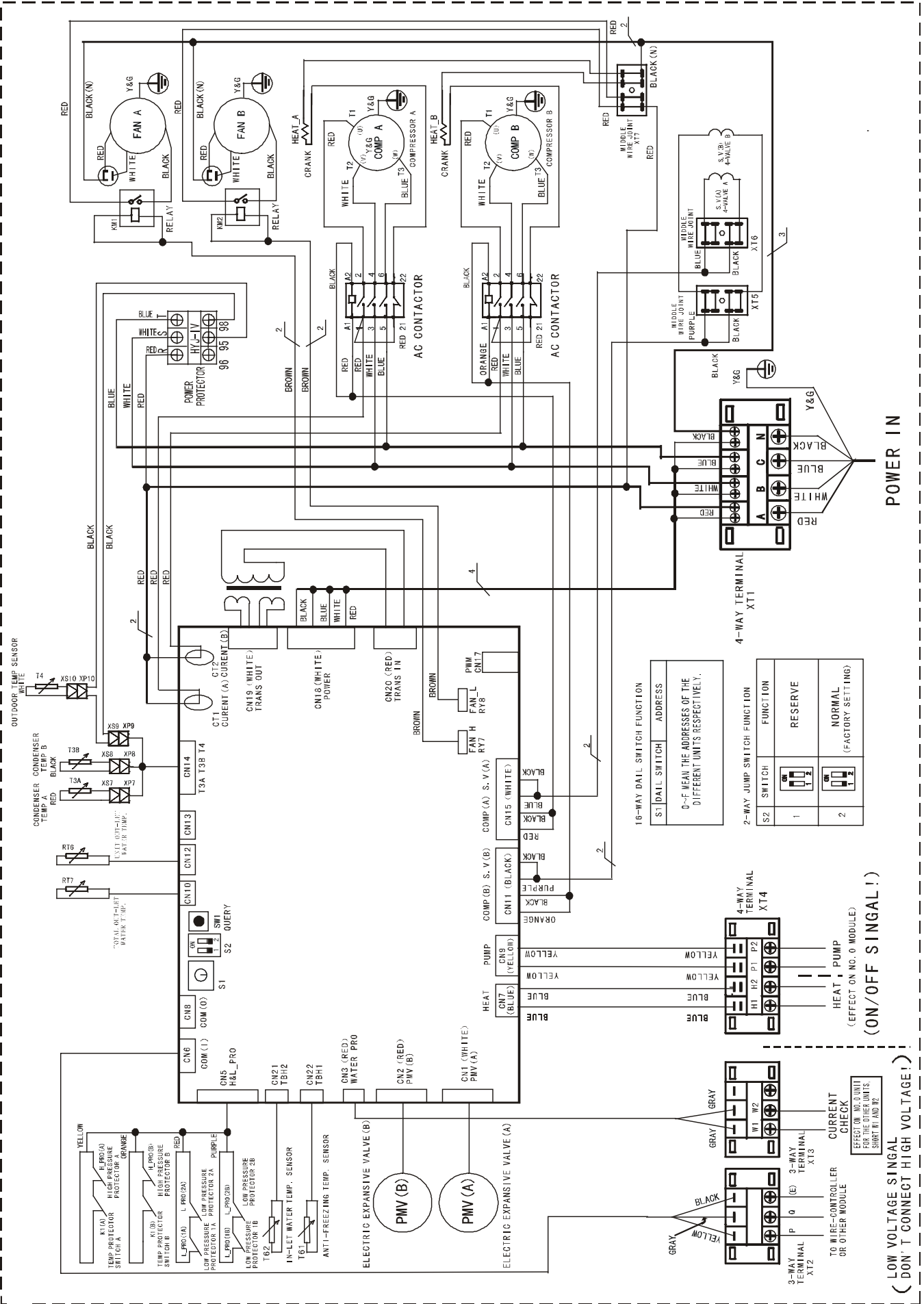

MCCH130A-SA3L

OUTDOOR WIRING DIAGRAM
202009019118

FOR PARTS & SERVICE INFORMATION

WARRANTY SERVICE ADDRESS

2. PLEASE REFER TO THE SERVICE MANUAL FOR THE LOCATION OF THE SERVICE POINTS.

REFLECT RETURN

CONDENSER FAN	CONDENSER FAN	CONDENSER FAN	CONDENSER FAN	CONDENSER FAN	CONDENSER FAN	CONDENSER FAN	CONDENSER FAN
CONDENSER FAN	CONDENSER FAN	CONDENSER FAN	CONDENSER FAN	CONDENSER FAN	CONDENSER FAN	CONDENSER FAN	CONDENSER FAN

CONDENSER FAN SPEED

CONDENSER FAN	CONDENSER FAN	CONDENSER FAN	CONDENSER FAN	CONDENSER FAN	CONDENSER FAN	CONDENSER FAN	CONDENSER FAN
CONDENSER FAN	CONDENSER FAN	CONDENSER FAN	CONDENSER FAN	CONDENSER FAN	CONDENSER FAN	CONDENSER FAN	CONDENSER FAN

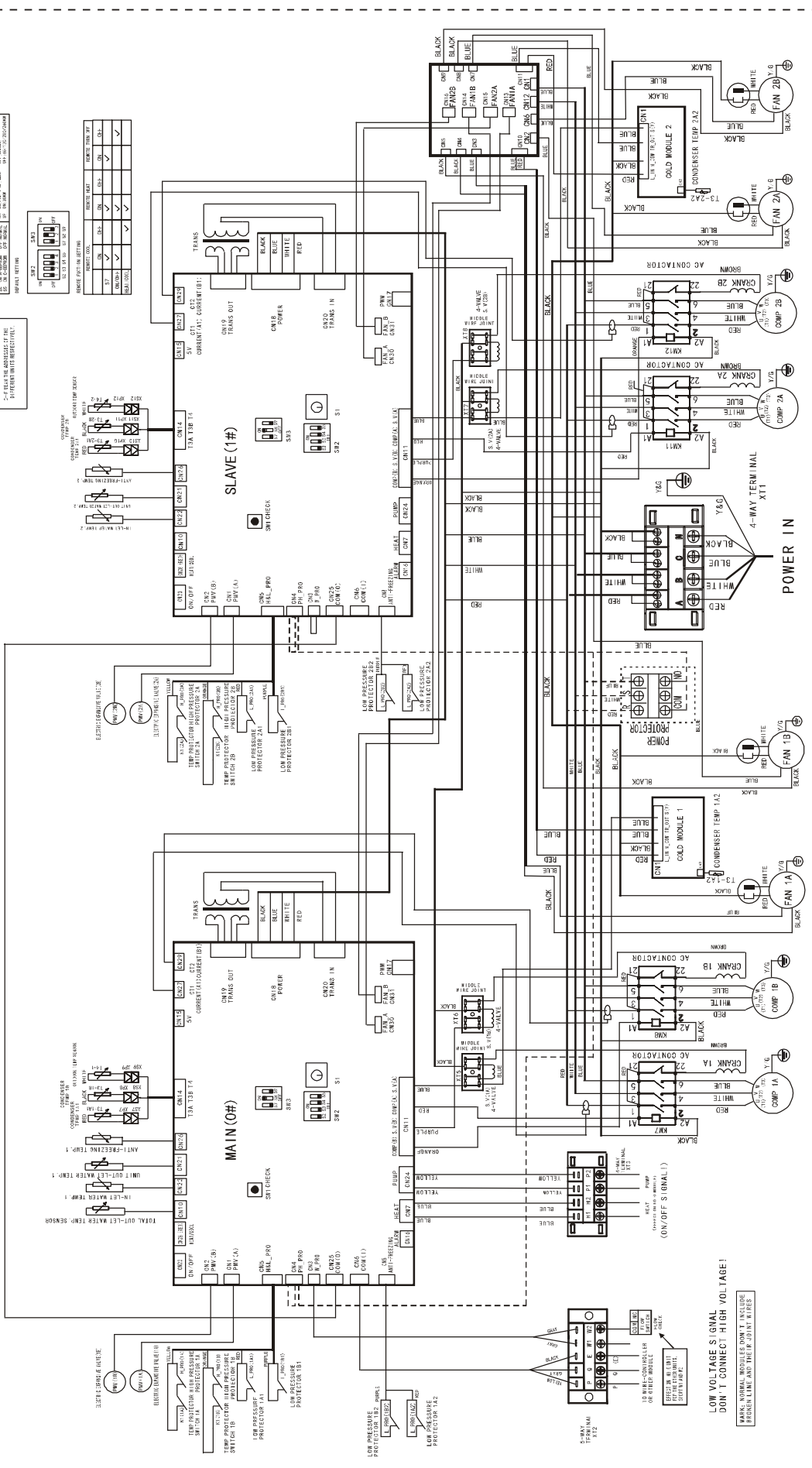

LOW VOLTAGE SIGNAL
DON'T CONNECT HIGH VOLTAGE!

MARKS NORMAL MODULE DON'T INCLUDE
NORMAL WIRE CAN USE OUTLINE WIRE

Attached Drawing (I) Electric Drawing of Main Unit and Auxiliary Unit

2D209001A0355

NO.	DESCRIPTION	REVISION
1	REVISED TO ADD 3RD UNIT	1
2	REVISED TO ADD 2ND UNIT	2
3	REVISED TO ADD 1ST UNIT	3

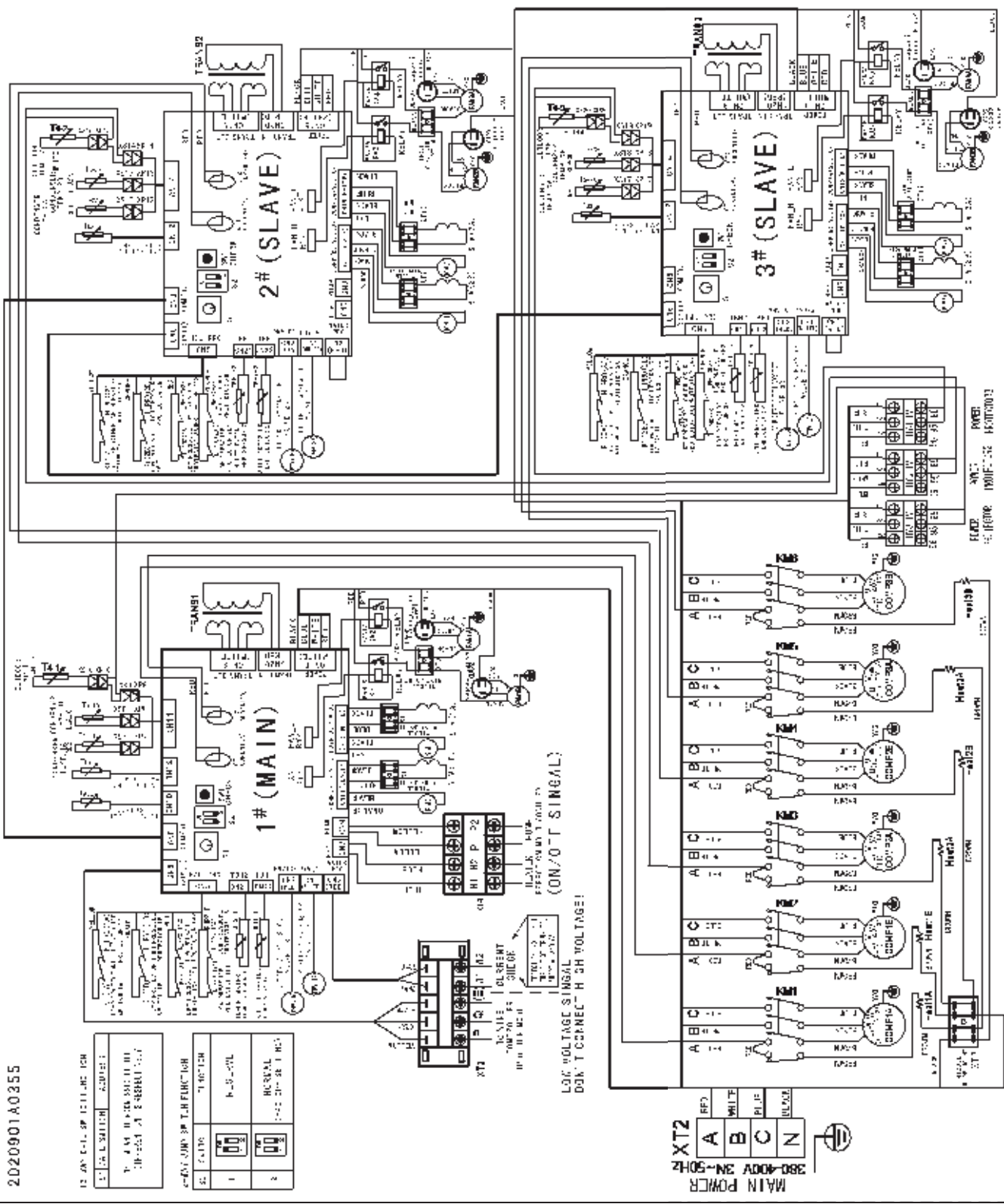

250 kW module

Attached Drawing (I) Electric Drawing of Main Unit and Auxiliary Unit

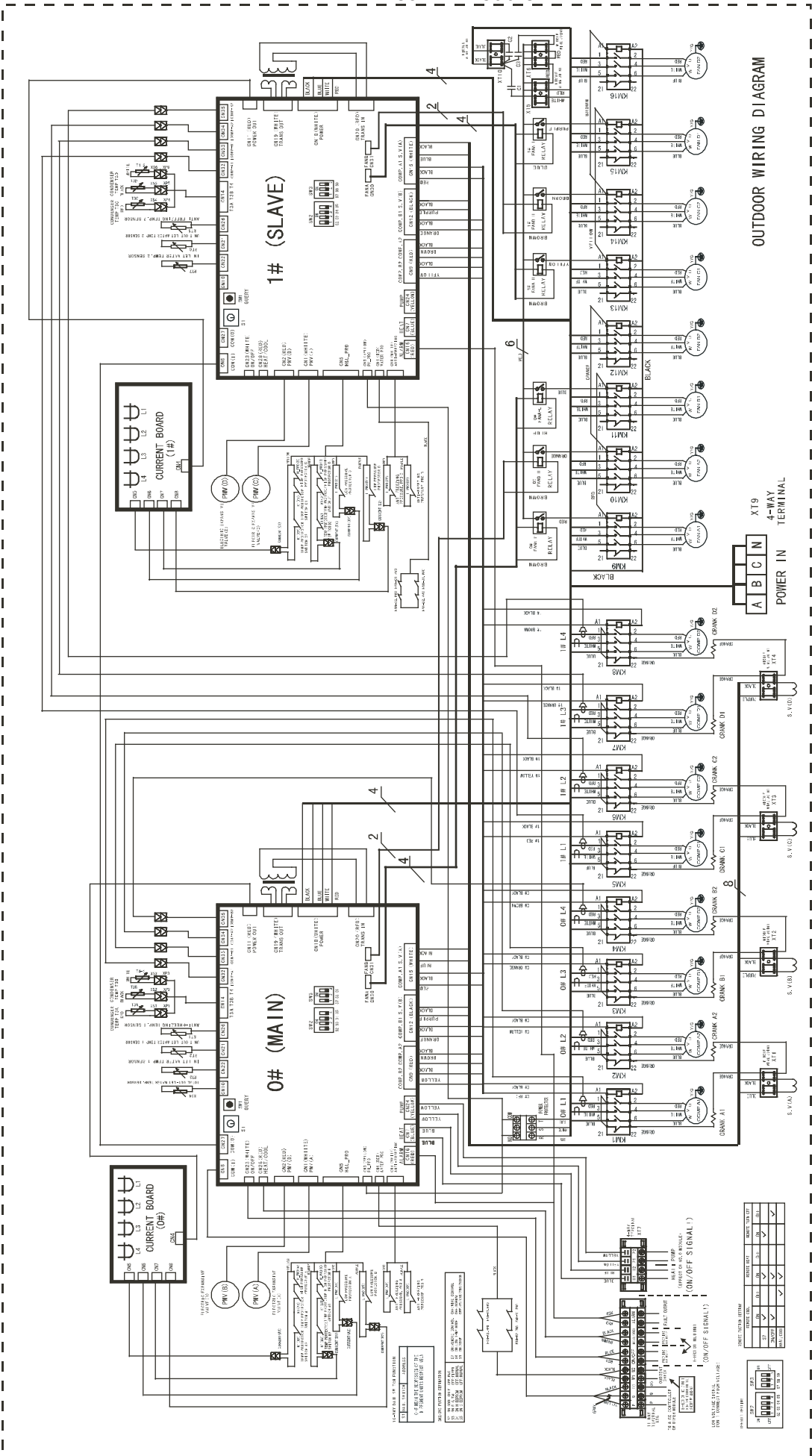

7.2 Networking communication schematic of main unit and auxiliary unit

30kW module(Only for MCCH30A-TA3SL , MCDH30A-TA3SL)

Attached picture (II) Networking Communication Schematic of Main Unit and Auxiliary Unit

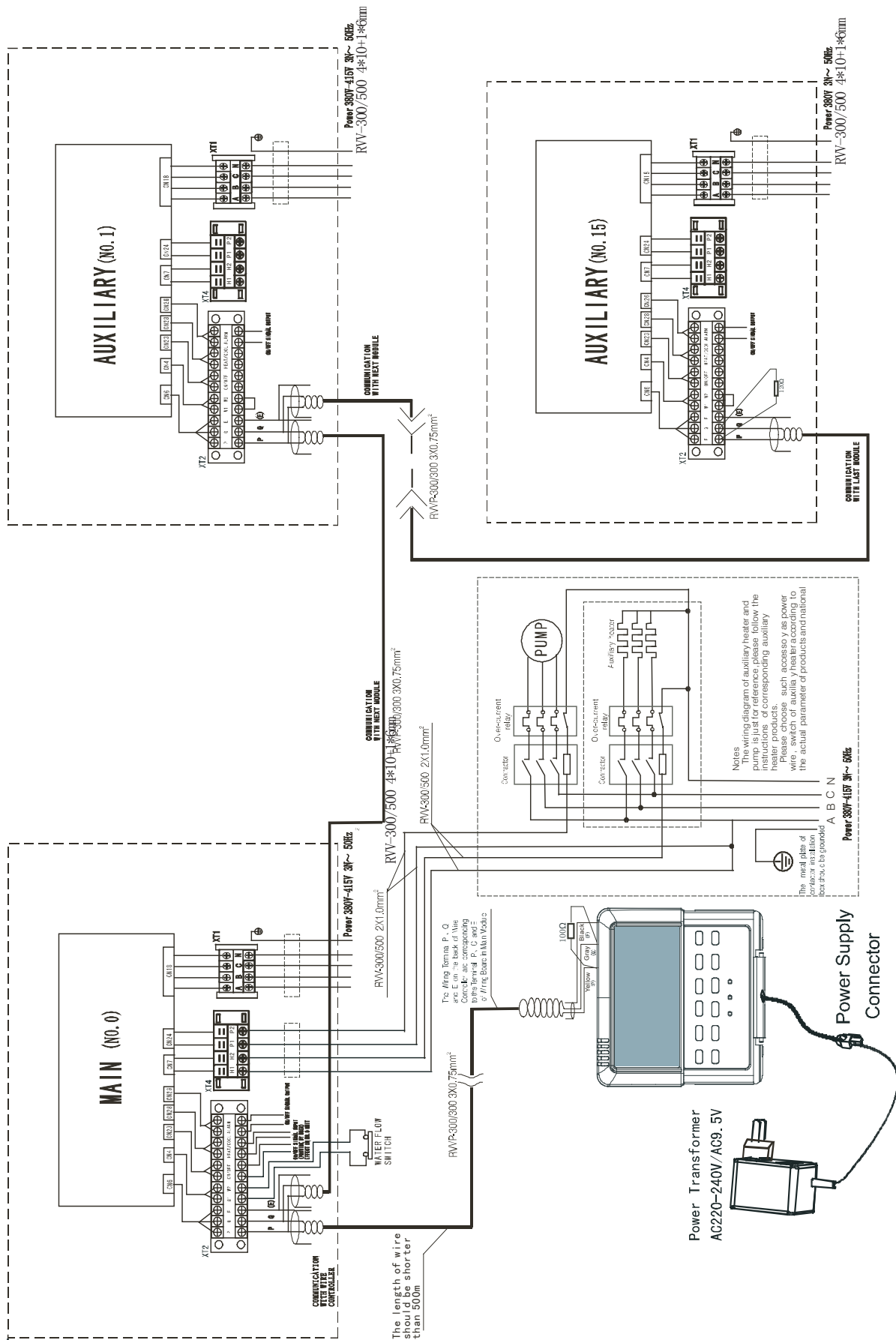

8 Electric Characteristics

Model	Outdoor Unit				Power Supply		Compressor		OFM	
	Hz	Voltage	Min.	Max.	TOCA	MFA	LRA	RLA	KW	FLA
MCCH30A-TA3SL	50	380-415	342	456	25.3	25	74(×2)	11.8(×2)	0.55	4.0
MCDH30A-TA3SL	50	380-415	342	456	25.3	25	74(×2)	11.8(×2)	0.55	4.0
MCCH65A-SA3L	50	380-400	342	440	52	70	147(×2)	21.4(×2)	0.865(×2)	4.0(×2)
MCDH65A-SA3L	50	380-415	342	456	52	70	118/74/82.4	17.8/9.1/9.8	0.865(×2)	4.0(×2)
MCCH130A-SA3L	50	380-400	342	440	130	200	147(×4)	21.4(×4)	0.88(×4)	4.0(×4)
MCCH185A-SA3	50	380-400	342	440	160	180	147(×6)	21.4(×6)	0.88(×6)	4.0(×6)
MCCH250A-SA3T	50	380-400	342	440	191	280	177(×8)	20.8(×8)	0.7(×8)	1.8(×8)

Remark:

TOCA: Total Over-current Amps. (A)

MFA: Max. Fuse Amps. (A)

LRA: Locked Rotor Amps. (A)

RLA: Rated Load Amps. (A)

OFM: Outdoor Fan Motor.

KW: Rated Motor Input (KW)

FLA: Full Load Amps.

9 Capacity Tables

9.1 MCC(D)H30A-TA3SL

Cooling:

Chilled water outlet temp. (°C)	Ambient temp.(°C)											
	21.00		25.00		30.00		35.00		40.00		46.00	
	Capacity KW	Power KW	Capacity KW	Power KW	Capacity KW	Power KW	Capacity KW	Power KW	Capacity KW	Power KW	Capacity KW	Power KW
5.00	33.59	8.81	31.63	9.08	29.84	9.36	28.20	9.65	26.42	10.13	24.31	10.64
6.00	34.72	8.94	32.66	9.22	30.79	9.51	29.07	9.80	27.27	10.29	25.11	10.80
7.00	35.93	9.13	33.77	9.41	31.80	9.70	30.00	10.00	28.17	10.50	25.97	11.03
8.00	37.04	9.40	34.78	9.69	32.72	9.99	30.84	10.30	28.99	10.82	26.76	11.36
9.00	38.09	9.49	35.73	9.79	33.58	10.09	31.62	10.40	29.75	10.92	27.49	11.47
10.00	39.53	9.63	37.05	9.93	34.79	10.24	32.73	10.56	30.83	11.08	28.52	11.64
11.00	40.63	9.73	38.05	10.03	35.69	10.34	33.54	10.66	31.63	11.19	29.29	11.75
12.00	41.56	9.87	38.88	10.18	36.44	10.49	34.22	10.82	32.30	11.36	29.94	11.92
13.00	42.31	9.95	39.54	10.26	37.02	10.58	34.73	10.90	32.82	11.45	30.46	12.02
14.00	43.36	10.02	40.48	10.33	37.87	10.65	35.49	10.98	33.58	11.53	31.19	12.10
15.00	43.92	10.07	40.97	10.38	38.29	10.70	35.85	11.03	33.95	11.58	31.57	12.16

Note:

The inlet/outlet water temperature difference is 5°C.

Heating:

Hot water outlet temp. (°C)	Ambient temp.(°C)													
	-10		-6		-2		2		7		10		13	
	Capacity	Power	Capacity	Power	Capacity	Power	Capacity	Power	Capacity	Power	Capacity	Power	Capacity	Power
(°C)	KW	KW	KW	KW	KW	KW	KW	KW	KW	KW	KW	KW	KW	KW
40.00	19.89	6.13	24.86	6.97	29.25	7.74	32.50	8.42	35.33	8.86	39.57	9.39	45.50	10.14
41.00	19.22	6.26	24.06	7.11	28.34	7.90	31.52	8.59	34.30	9.04	38.34	9.58	44.02	10.35
42.00	18.67	6.38	23.39	7.26	27.58	8.06	30.72	8.76	33.46	9.22	37.34	9.78	42.79	10.56
43.00	18.22	6.52	22.86	7.40	26.98	8.23	30.08	8.94	32.80	9.41	36.54	9.98	41.81	10.77
44.00	17.86	6.65	22.44	7.55	26.53	8.39	29.61	9.12	32.32	9.60	35.94	10.18	41.04	10.99
45.00	17.60	6.78	22.14	7.71	26.21	8.57	29.28	9.31	32.00	9.80	35.52	10.39	40.49	11.22
46.00	17.26	6.85	21.74	7.79	25.76	8.65	28.81	9.40	31.52	9.90	34.92	10.49	39.74	11.33
47.00	16.75	6.99	21.12	7.94	25.06	8.82	28.06	9.59	30.73	10.10	33.99	10.70	38.61	11.56
48.00	16.09	7.20	20.31	8.18	24.13	9.09	27.05	9.88	29.66	10.40	32.74	11.02	37.13	11.90
49.00	15.21	7.49	19.23	8.51	22.87	9.45	25.67	10.27	28.17	10.81	31.05	11.46	35.15	12.38
50.00	14.23	7.86	18.02	8.93	21.45	9.92	24.10	10.79	26.48	11.36	29.13	12.04	32.92	13.00

Note:

The inlet/outlet water temperature difference is 5°C.

9.2

MCC(D)H65A-SA3L

Cooling

Chilled water outlet temp. (°C)	Ambient temp.(°C)											
	21.00		25.00		30.00		35.00		40.00		46.00	
	Capacity	Power	Capacity	Power	Capacity	Power	Capacity	Power	Capacity	Power	Capacity	Power
	KW	KW	KW	KW	KW	KW	KW	KW	KW	KW	KW	KW
5.00	72.77	17.97	68.52	18.52	64.64	19.10	61.10	19.69	57.25	20.67	52.67	21.70
6.00	75.23	18.25	70.77	18.81	66.70	19.39	62.99	19.99	59.08	20.99	54.41	22.04
7.00	77.85	18.62	73.17	19.19	68.90	19.79	65.00	20.40	61.04	21.42	56.27	22.49
8.00	80.26	19.18	75.36	19.77	70.90	20.38	66.82	21.01	62.81	22.06	57.97	23.17
9.00	82.52	19.36	77.41	19.96	72.76	20.58	68.51	21.22	64.47	22.28	59.57	23.39
10.00	85.65	19.65	80.27	20.26	75.38	20.89	70.91	21.53	66.80	22.61	61.79	23.74
11.00	88.04	19.85	82.44	20.46	77.33	21.09	72.68	21.75	68.54	22.83	63.47	23.98
12.00	90.06	20.14	84.24	20.76	78.95	21.40	74.13	22.06	69.98	23.17	64.87	24.33
13.00	91.66	20.30	85.67	20.93	80.21	21.57	75.25	22.24	71.11	23.35	65.99	24.52
14.00	93.94	20.44	87.72	21.07	82.05	21.72	76.90	22.40	72.75	23.52	67.58	24.69
15.00	95.15	20.54	88.76	21.18	82.95	21.83	77.67	22.51	73.55	23.63	68.41	24.81

Note:

The inlet/outlet water temperature difference is 5°C.

Heating:

Hot water outlet temp. (°C)	Ambient temp.(°C)													
	-10		-6		-2		2		7		10		13	
	Capacity	Power	Capacity	Power	Capacity	Power	Capacity	Power	Capacity	Power	Capacity	Power	Capacity	Power
	KW	KW	KW	KW	KW	KW	KW	KW	KW	KW	KW	KW	KW	KW
40.00	42.89	13.45	53.61	15.29	63.07	16.99	70.08	18.46	76.17	19.43	85.31	20.60	98.11	22.25
41.00	41.45	13.73	51.87	15.60	61.10	17.33	67.96	18.84	73.95	19.83	82.68	21.02	94.92	22.70
42.00	40.25	14.01	50.44	15.92	59.48	17.69	66.23	19.22	72.15	20.24	80.52	21.45	92.28	23.17
43.00	39.28	14.29	49.28	16.24	58.18	18.05	64.86	19.62	70.74	20.65	78.80	21.89	90.15	23.64
44.00	38.52	14.58	48.39	16.57	57.20	18.42	63.84	20.02	69.69	21.07	77.50	22.33	88.50	24.12
45.00	37.96	14.88	47.75	16.91	56.51	18.79	63.14	20.43	69.00	21.50	76.59	22.79	87.31	24.61
46.00	37.22	15.03	46.87	17.08	55.54	18.98	62.12	20.63	67.97	21.72	75.31	23.02	85.70	24.86
47.00	36.12	15.33	45.54	17.42	54.03	19.36	60.50	21.04	66.27	22.15	73.29	23.48	83.26	25.36
48.00	34.69	15.79	43.80	17.95	52.02	19.94	58.32	21.67	63.95	22.81	70.60	24.18	80.06	26.12
49.00	32.80	16.42	41.47	18.66	49.31	20.74	55.34	22.54	60.75	23.73	66.95	25.15	75.78	27.16
50.00	30.69	17.24	38.85	19.60	46.25	21.77	51.96	23.67	57.10	24.91	62.81	26.41	70.98	28.52

Note:
The inlet/outlet water temperature difference is 5°C.

9.3. MCCH130A-SA3L**Cooling:**

Chilled water outlet temp. (°C)	Ambient temp.(°C)											
	21.00		25.00		30.00		35.00		40.00		46.00	
	Capacity	Power	Capacity	Power	Capacity	Power	Capacity	Power	Capacity	Power	Capacity	Power
	KW	KW	KW	KW	KW	KW	KW	KW	KW	KW	KW	KW
5.00	145.54	35.93	137.04	37.05	129.29	38.19	122.20	39.37	114.50	41.34	105.34	43.41
6.00	150.46	36.49	141.54	37.62	133.40	38.78	125.97	39.98	118.16	41.98	108.83	44.08
7.00	155.71	37.24	146.34	38.39	137.80	39.58	130.00	40.80	122.07	42.84	112.55	44.98
8.00	160.52	38.35	150.72	39.54	141.79	40.76	133.64	42.02	125.62	44.13	115.95	46.33
9.00	165.05	38.73	154.83	39.92	145.52	41.16	137.02	42.43	128.94	44.55	119.14	46.78
10.00	171.31	39.31	160.55	40.52	150.75	41.78	141.82	43.07	133.59	45.22	123.57	47.48
11.00	176.08	39.69	164.87	40.92	154.66	42.19	145.36	43.49	137.08	45.67	126.93	47.95
12.00	180.11	40.28	168.49	41.52	157.91	42.81	148.27	44.13	139.97	46.34	129.75	48.65
13.00	183.33	40.60	171.33	41.85	160.42	43.15	150.49	44.48	142.22	46.71	131.98	49.04
14.00	187.89	40.88	175.43	42.14	164.11	43.45	153.80	44.79	145.50	47.03	135.17	49.38
15.00	190.30	41.08	177.52	42.35	165.90	43.66	155.34	45.01	147.11	47.26	136.81	49.63

Note:

The inlet/outlet water temperature difference is 5°C.

Heating:

Hot water outlet temp. (°C)	Ambient temp.(°C)													
	-10		-6		-2		2		7		10		13	
	Capacity KW	Power KW	Capacity KW	Power KW	Capacity KW	Power KW	Capacity KW	Power KW	Capacity KW	Power KW	Capacity KW	Power KW	Capacity KW	Power KW
40.00	85.78	26.91	107.22	30.57	126.14	33.97	140.16	36.93	152.34	38.87	170.63	38.33	196.22	41.39
41.00	82.89	27.45	103.75	31.20	122.20	34.66	135.93	37.68	147.91	39.66	165.36	39.11	189.83	42.24
42.00	80.50	28.01	100.87	31.83	118.96	35.37	132.47	38.45	144.30	40.47	161.04	39.91	184.55	43.10
43.00	78.55	28.59	98.56	32.48	116.37	36.09	129.73	39.23	141.47	41.30	157.60	40.72	180.29	43.98
44.00	77.03	29.17	96.78	33.15	114.39	36.83	127.67	40.03	139.38	42.14	154.99	41.55	177.00	44.88
45.00	75.92	29.76	95.49	33.82	113.01	37.58	126.27	40.85	138.00	43.00	153.18	45.58	174.63	49.23
46.00	74.43	30.06	93.74	34.16	111.07	37.96	124.24	41.26	135.93	43.43	150.61	46.04	171.39	49.72
47.00	72.23	30.66	91.09	34.85	108.05	38.72	121.00	42.08	132.53	44.30	146.58	46.96	166.52	50.71
48.00	69.38	31.58	87.60	35.89	104.04	39.88	116.64	43.35	127.89	45.63	141.19	48.37	160.11	52.23
49.00	65.61	32.85	82.94	37.33	98.62	41.47	110.69	45.08	121.50	47.45	133.89	50.30	151.56	54.32
50.00	61.38	34.49	77.70	39.19	92.50	43.55	103.93	47.33	114.21	49.83	125.63	52.81	141.96	57.04

Note:

The inlet/outlet water temperature difference is 5°C.

9.4 MCCH185A-SA3**Cooling:**

Chilled water outlet temp.	Ambient temp.(°C)											
	21.00		25.00		30.00		35.00		40.00		46.00	
	Capacity	Power	Capacity	Power	Capacity	Power	Capacity	Power	Capacity	Power	Capacity	Power
(°C)	KW	KW	KW	KW	KW	KW	KW	KW	KW	KW	KW	KW
5.00	207.12	55.49	195.03	57.20	183.99	58.97	173.90	60.80	162.94	63.83	149.91	67.03
6.00	214.11	56.35	201.42	58.09	189.84	59.89	179.27	61.74	168.15	64.83	154.87	68.07
7.00	221.59	57.50	208.26	59.28	196.10	61.11	185.00	63.00	173.72	66.15	160.17	69.46
8.00	228.44	59.22	214.49	61.06	201.78	62.94	190.18	64.89	178.77	68.13	165.00	71.54
9.00	234.87	59.80	220.33	61.65	207.08	63.55	194.99	65.52	183.49	68.80	169.54	72.24
10.00	237.19	60.70	222.30	62.57	208.73	64.51	196.36	66.50	184.97	69.83	171.10	73.32
11.00	243.81	61.29	228.28	63.19	214.15	65.14	201.27	67.16	189.80	70.52	175.75	74.04
12.00	249.38	62.19	233.29	64.11	218.64	66.10	205.29	68.14	193.80	71.55	179.65	75.13
13.00	253.84	62.69	237.23	64.63	222.13	66.63	208.37	68.69	196.91	72.12	182.74	75.73
14.00	260.15	63.12	242.91	65.08	227.23	67.09	212.96	69.16	201.46	72.62	187.15	76.25
15.00	263.49	63.43	245.79	65.40	229.71	67.42	215.09	69.50	203.69	72.98	189.43	76.63

Note:

The inlet/outlet water temperature difference is 5°C.

Heating:

Hot water outlet temp. (°C)	Ambient temp.(°C)													
	-10		-6		-2		2		7		10		13	
	Capacity	Power	Capacity	Power	Capacity	Power	Capacity	Power	Capacity	Power	Capacity	Power	Capacity	Power
	KW	KW	KW	KW	KW	KW	KW	KW	KW	KW	KW	KW	KW	KW
40.00	124.31	38.17	155.39	43.37	182.81	48.19	203.13	52.38	220.79	55.14	247.28	58.45	284.38	63.12
41.00	120.14	38.95	150.36	44.26	177.10	49.18	197.00	53.45	214.36	56.26	239.65	59.64	275.12	64.41
42.00	116.66	39.74	146.19	45.16	172.40	50.18	191.98	54.54	209.13	57.41	233.39	60.86	267.46	65.73
43.00	113.85	40.55	142.84	46.08	168.65	51.20	188.01	55.66	205.03	58.58	228.40	62.10	261.29	67.07
44.00	111.64	41.38	140.26	47.02	165.79	52.25	185.03	56.79	202.00	59.78	224.62	63.37	256.52	68.44
45.00	110.03	42.22	138.40	47.98	163.79	53.31	183.00	57.95	200.00	61.00	222.00	64.66	253.08	69.83
46.00	107.87	42.65	135.86	48.46	160.97	53.85	180.06	58.53	197.00	61.61	218.28	65.31	248.40	70.53
47.00	104.69	43.50	132.01	49.43	156.60	54.92	175.36	59.70	192.08	61.81	212.43	66.61	241.33	71.94
48.00	100.55	44.80	126.96	50.91	150.78	56.57	169.04	61.49	185.35	63.67	204.63	68.61	232.05	74.10
49.00	95.08	46.60	120.20	52.95	142.93	58.83	160.41	63.95	176.08	66.21	194.05	71.36	219.66	77.06
50.00	88.96	48.93	112.61	55.60	134.05	61.78	150.62	67.15	165.52	69.52	182.07	74.92	205.74	80.92

Note:

The inlet/outlet water temperature difference is 5°C.

9.5 MCCH250A-SA3T**Cooling:**

Chilled water outlet temp. (°C)	Ambient temp.(°C)													
	21.00		25.00		30.00		35.00		40.00		46.00		52.00	
	Capacity	Power	Capacity	Power	Capacity	Power	Capacity	Power	Capacity	Power	Capacity	Power	Capacity	Power
	KW	KW	KW	KW	KW	KW	KW	KW	KW	KW	KW	KW	KW	KW
5.00	279.89	68.96	263.55	71.09	248.63	73.29	235.00	75.56	220.20	79.34	202.58	83.30	182.32	87.47
6.00	289.34	70.03	272.19	72.20	256.54	74.43	242.25	76.73	227.23	80.57	209.28	84.60	188.56	88.83
7.00	299.44	71.46	281.43	73.67	265.00	75.95	250.00	78.30	234.75	82.22	216.44	86.33	195.23	90.64
8.00	308.70	73.61	289.86	75.88	272.68	78.23	257.00	80.65	241.58	84.68	222.98	88.92	201.35	93.36
9.00	317.40	74.32	297.75	76.62	279.84	78.99	263.50	81.43	247.95	85.50	229.11	89.78	207.11	94.27
10.00	329.43	75.44	308.75	77.77	289.90	80.17	272.72	82.65	256.90	86.79	237.64	91.13	215.06	95.68
11.00	338.62	76.18	317.06	78.53	297.43	80.96	279.54	83.47	263.61	87.64	244.10	92.02	221.15	96.62
12.00	346.37	77.29	324.01	79.68	303.66	82.15	285.13	84.69	269.16	88.92	249.52	93.37	226.31	98.04
13.00	352.55	77.91	329.49	80.32	308.51	82.81	289.41	85.37	273.49	89.64	253.80	94.12	230.45	98.82
14.00	361.32	78.45	337.37	80.88	315.59	83.38	295.78	85.96	279.80	90.26	259.94	94.77	236.28	99.51
15.00	365.96	78.84	341.38	81.28	319.05	83.79	298.73	86.38	282.90	90.70	263.10	95.24	239.42	100.00

Note:

The inlet/outlet water temperature difference is 5°C.

Heating

Hot water outlet temp. (°C)	Ambient temp.(°C)													
	-10.00		-6.00		-2		2		7		10		13	
	Capacity	Power	Capacity	Power	Capacity	Power	Capacity	Power	Capacity	Power	Capacity	Power	Capacity	Power
(°C)	KW	KW	KW	KW	KW	KW	KW	KW	KW	KW	KW	KW	KW	KW
39.00	167.82	50.06	209.78	56.88	246.80	63.20	274.22	68.70	298.07	72.31	333.83	76.65	383.91	82.78
41.00	162.18	51.08	202.98	58.04	239.08	64.49	265.94	70.10	289.38	73.79	323.53	78.22	371.41	84.47
42.00	157.50	52.12	197.36	59.23	232.74	65.81	259.18	71.53	282.33	75.30	315.08	79.81	361.08	86.20
43.00	153.69	53.18	192.84	60.44	227.67	67.15	253.82	72.99	276.79	76.83	308.34	81.44	352.75	87.96
44.00	150.72	54.27	189.35	61.67	223.81	68.52	249.79	74.48	272.70	78.40	303.24	83.10	346.30	89.75
45.00	148.54	55.38	186.84	62.93	221.11	69.92	247.05	76.00	270.00	80.00	299.70	84.80	341.66	91.58
46.00	145.63	55.93	183.41	63.56	217.31	70.62	243.08	76.76	265.95	80.80	294.67	85.65	335.34	92.50
47.00	141.33	57.05	178.22	64.83	211.41	72.03	236.74	78.30	259.30	82.42	286.79	87.36	325.79	94.35
48.00	135.75	58.76	171.40	66.77	203.56	74.19	228.21	80.64	250.23	84.89	276.25	89.98	313.27	97.18
49.00	128.36	61.11	162.27	69.44	192.95	77.16	216.56	83.87	237.71	88.28	261.96	93.58	296.54	101.07
50.00	120.09	64.17	152.02	72.92	180.97	81.02	203.34	88.06	223.45	92.70	245.80	98.26	277.75	106.12

Note:

The inlet/outlet water temperature difference is 5°C.

10 Troubleshooting

Failure & Protection Codes of the Module

30kW module
(For MCCH30A-TA3SL and MCDH30A-TA3SL only)

No,	Code	Trouble
1	E0	Error of outdoor EEPROM
2	E1	Power phase sequence error
3	E2	Communication error
4	E3	Total outlet water temperature sensor error (Be valid for main unit)
5	E4	Unit outlet water temperature sensor error
6	E5	Pipe temperature sensor error in condenser A
7	E6	Pipe temperature sensor error in condenser B
8	E7	Outdoor ambient temperature sensor error
9	E8	Output of the power protector error
10	E9	Water flow detection error(manual recovery)
11	EA	(Reserved failure code)
12	Eb	Anti-freezing temperature sensor error in shell and tube exchanger
13	EC	Wired controller detected that the units on-line have decreased.
14	Ed	(Reserved failure code)
15	EF	Inlet water temperature sensor error
16	P0	High pressure or air discharge temperature protection in system A (manual recovery)
17	P1	Low pressure protection in system A (manual recovery)
18	P2	High pressure or air discharge temperature protection in system B (manual recovery)
19	P3	Low pressure protection in system B (manual recovery)
20	P4	Current protection in system A (manual recovery)
21	P5	Current protection in system B (manual recovery)
22	P6	Condenser high temperature protection in system A
23	P7	Condenser high temperature protection in system B
24	P8	(Reserved failure code)
25	P9	Outlet and inlet water temperature difference protection
26	PA	Low ambient temperature drive-up protection
27	Pb	System anti-freezing protection
28	PC	Anti-freezing pressure protection in system A (manual recovery)
29	Pd	Anti-freezing pressure protection in system B (manual recovery)
30	PE	Low-temperature protection of evaporator (manual recovery)

65kW module (For MCCH65A-SA3L, MCCD65A-SA3L)

No	Code	Trouble
1	E0	Error of outdoor EEPROM
2	E1	Power phase sequence error
3	E2	Communication error
4	E3	Total water outlet temperature sensor error (Be valid for main unit)
5	E4	Unit outlet water temperature sensor error
6	E5	Pipe temperature sensor error in condenser A
7	E6	Pipe temperature sensor error in condenser B
8	E7	Outdoor ambient temperature sensor error
9	E8	Output of the power protector error
10	E9	Water flow detection error(Manual recovery)
11	EA	(Reserved failure code)
12	Eb	Anti-freezing temperature sensor error in shell and tube exchanger
13	EC	Wired controller detected that the units on-line have decreased.
14	Ed	(Reserved failure code)
15	EF	Inlet water temperature sensor error
16	P0	High pressure or air discharge temperature protection in system A(Manual recovery)
17	P1	Low pressure protection in system A(Manual recovery)
18	P2	High pressure or air discharge temperature protection in system B(Manual recovery)
19	P3	Low pressure protection in system B(Manual recovery)
20	P4	Current protection in system A(Manual recovery)
21	P5	Current protection in system B(Manual recovery)
22	P6	Condenser high pressure protection in system A
23	P7	Condenser high pressure protection in system B
24	P8	(Reserved failure code)
25	P9	Outlet and inlet water temperature difference protection
26	PA	Low ambient temperature drive-up protection
27	Pb	System anti-freezing protection
28	Pc	Anti-freezing pressure protection in system A(Manual recovery)
29	Pd	Anti-freezing pressure protection in system B(Manual recovery)
30	PE	Low-temperature protection of evaporator(Manual recovery)

130kW module (MCCH130A-SA3L)

No	Code	Trouble
1	E0	Error of outdoor EEPROM
2	E1	Power phase sequence error
3	E2	Communication error
4	E3	Total water outlet temperature sensor error (Be valid for main unit)
5	E4	Unit outlet water temperature sensor error
6	E5	Pipe temperature sensor error in condenser A
7	E6	Pipe temperature sensor error in condenser B
8	E7	Outdoor ambient temperature sensor error
9	E8	Output of the power protector error
10	E9	Water flow detection error(Manual recovery)
11	EA	(Reserved failure code)
12	Eb	Anti-freezing temperature sensor error in shell and tube exchanger
13	EC	Wired controller detected that the units on-line have decreased.
14	Ed	(Reserved failure code)
15	EF	Inlet water temperature sensor error
16	P0	High pressure or air discharge temperature protection in system A(Manual recovery)
17	P1	Low pressure protection in system A(Manual recovery)
18	P2	High pressure or air discharge temperature protection in system B(Manual recovery)
19	P3	Low pressure protection in system B(Manual recovery)
20	P4	Current protection in system A(Manual recovery)
21	P5	Current protection in system B(Manual recovery)
22	P6	Condenser high pressure protection in system A
23	P7	Condenser high pressure protection in system B
24	P8	(Reserved failure code)
25	P9	Outlet and inlet water temperature difference protection
26	PA	Low ambient temperature drive-up protection
27	Pb	System anti-freezing protection
28	Pc	Anti-freezing pressure protection in system A(Manual recovery)
29	Pd	Anti-freezing pressure protection in system B(Manual recovery)
30	PE	Low-temperature protection of evaporator(Manual recovery)

185 kW module MCCH185A-SA3

No,	Code	Trouble
1	E0	Water flow detection error (The third time)
2	E1	Power phase sequence error
3	E2	Communication error
4	E3	Total water outlet temperature sensor error
5	E4	Outlet water temperature sensor error in shell and tube exchanger
6	E5	Pipe temperature sensor error in condenser A
7	E6	Pipe temperature sensor error in condenser B
8	E7	Outdoor ambient temperature sensor error
9	E8	Air discharge temperature sensor error in digital compressor in system A
10	E9	Water flow detection error (The first and second times)
11	EA	Main unit detected that auxiliary unit's quantity have decreased
12	Eb	Anti-freezing temperature sensor 1 error in heat exchanger
13	EC	Wired controller did not find out any on-line module unit
14	Ed	1-hour consecutive 3-times PE protection
15	EF	Inlet water temperature sensor error
16	P0	High pressure or air discharge temperature protection in system A
17	P1	Low pressure protection in system A
18	P2	High pressure or air discharge temperature protection in system B
19	P3	Low pressure protection in system B
20	P4	Current protection in system A
21	P5	Current protection in system B
22	P6	Condenser high pressure protection in system A
23	P7	Condenser high pressure protection in system B
24	P8	(Reserved failure code)
25	P9	Outlet and inlet water temperature difference protection
26	PA	Low ambient temperature drive-up protection
27	Pb	System anti-freezing protection
28	PC	(Reserved failure code)
29	PE	Low-temperature protection of shell and tube heat exchanger
30	F1	Wired controller failure
31	F2	(Reserved failure code)

250 kW module MCCH250A-SA3T

No.	Code	Trouble
1	E0	Error of outdoor EEPROM
2	E1	Power phase sequence error
3	E2	Communication error
4	E3	Error of total outlet water temperature sensor(Be valid for main unit)
5	E4	Outlet water temperature sensor error in shell and tube exchanger
6	E5	Pipe temperature sensor error in condenser A
7	E6	Pipe temperature sensor error in condenser B
8	E7	Outdoor ambient temperature sensor error
9	E8	Output of the power protector error
10	E9	Water flow detection error(manual recovery)
11	EA	(Reserved failure code)
12	Eb	Anti-freezing temperature sensor error in shell and tube exchanger
13	EC	Wired controller detected that the units on-line have decreased.
14	Ed	(Reserved failure code)
15	EF	Inlet water temperature sensor error
16	P0	High pressure or air discharge temperature protection error in system A
17	P1	Low pressure protection in system A (manual recovery)
18	P2	High pressure or air discharge temperature protection in system B (manual recovery)
19	P3	Low pressure protection in system B (manual recovery)
20	P4	Current protection in system A (manual recovery)
21	P5	Current protection in system B (manual recovery)
22	P6	Condenser high temperature protection in system A
23	P7	Condenser high temperature protection in system B
24	P8	(Reserved failure code)
25	P9	Outlet and inlet water temperature difference protection
26	PA	Low ambient temperature drive-up protection
27	Pb	System anti-freezing protection
28	PC	Anti-freezing pressure protection in system A (manual recovery)
29	Pd	Anti-freezing pressure protection in system B (manual recovery)
30	PE	Low-temperature protection of evaporator (manual recovery)

10.2 Troubles and Solutions

Troubles	Possible reasons	Solutions
Over high air discharge pressure (Cooling operation).	Air or other non-condensing gas still in the system.	Discharge gas from refrigerant charging inlet. Re-vacuum the system if necessary.
	Fins in the condenser are dirty or foreign substance blocking fins.	Clean condenser fins.
	Insufficient chilling air volume or condenser fan error.	Check and repair the condenser fan, recover the normal operation.
	Excessive high air suction pressure.	See "Excessive high air suction pressure".
	Excessive refrigerant charging volume.	Discharge the excessive refrigerant.
	Over high ambient temperature.	Check ambient temperature.
Over low air discharge pressure (Cooling operation).	Surrounding temperature is lower.	Measure the surrounding temp.
	Refrigerant leak or insufficient.	Leak-hunting or recharging.
	Low suction pressure.	Refer to the "low suction pressure".
Over high air suction pressure (Cooling operation).	Refrigerant over-charged.	Discharge the additional refrigerant.
	High temperature of the inlet chilled-water.	Check the heat insulation of water pipeline.
Over low air suction pressure (Cooling operation).	Insufficient water flow.	Measure the Temp difference between inlet and outlet water, adjust the water flow.
	Low temperature of inlet chilled-water.	Check installation.
	Refrigerant leak or insufficient.	Leak-hunting or recharging.
	Scaling in the evaporator.	Descaling.
Over high air discharge pressure (Heating operation).	Insufficient water flow.	Check temperature difference at water inlet and outlet, and adjust the water flow volume.
	Air or other non-condensing gas still in the system.	Discharge gas from refrigerant charging inlet. Re-vacuum the system if necessary.
	Scaling in water side of heat exchanger.	Descaling.
	Over high temperature in chilling water inlet.	Check water temperature.
	Excessive high air suction pressure.	See "Excessive high air suction pressure".
Over low air discharge pressure (Heating operation).	Over low temperature of chilling water.	Check chilling water temperature.
	Refrigerant leakage or insufficient refrigerant volume.	Test leakage or charge sufficient refrigerant to the system.
	Excessive low air suction pressure.	See "Excessive low air suction pressure".
Over high air suction pressure (Heating operation).	Over heat air in the side of air heat exchanger.	Check ambient temperature around it.
	Excessive refrigerant charging volume.	Discharge the excessive refrigerant.
Over low air suction pressure (Heating operation).	Insufficient refrigerant charging volume.	Charge sufficient refrigerant to the system.
	Insufficient air flow volume.	Check fan rotating direction.
	Air loop short-circuit.	Reason about remove air short-circuit.
	Insufficient frost-removal operation.	Error comes out from 4-way valve or thermal resistor. Replace a new one if necessary.
Compressor stops because of freeze-proof protection (Cooling operation).	Insufficient chilling water flow volume.	Error comes from pump or flow-type water volume control. Check and repaired or replace a new one.
	Gas still in water loop.	Discharge air.
	Thermal resistor error.	Upon error have been confirmed, please replace a new one.
Compressor stops because of high pressure protection.	Over high air expelling pressure.	See "Over high air expelling pressure".
	High pressure switch error.	Upon error have been confirmed, please replace a new one.
Compressor stops because of motor overload.	Over high air expelling pressure and air suction pressure.	See "Over high air expelling pressure" and "Over high air suction pressure".
	High voltage or low voltage, signal phase or phase unbalance.	Confirm voltage not higher or lower than the rated voltage 10%.
	Short circuit comes out from motor or connecting interface.	Confirm resistors at motor are connected corresponding to terminals.
	Overload assembly error.	Replace a new one.

Troubles	Possible reasons	Solutions
Compressor stops because of integrate temperature sensor or air discharge temperature protection.	Over high or over low voltage.	Confirm voltage not higher or lower than the rated voltage 10%.
	Over high air expelling pressure or excessive low air suction pressure.	See "Over high air expelling pressure" and "excessive low air suction pressure".
	Component error.	Check the integrated temperature sensor after motor is cool down.
Compressor stops because of low pressure protection.	Filter in front (or rear) of expanding valve is blocked.	Replace a new filter.
	Low voltage switch error.	If the switch is defective, please replace a new one.
	Excessive low air suction pressure.	See "Excessive low air suction pressure".
Abnormal noise comes from compressor.	Liquid refrigerant flows into compressor from evaporator result in liquid slugging.	Adjust refrigerant charge volume.
	Aging of compressor.	Replace a new compressor.
Compressor can't start.	Over current relay trip up, fuse burnt out.	Replace damaged assembly.
	Control circuit without power though.	Check the wiring of control system.
	High voltage or low voltage protection.	Reference to mention in above the parts of air suction and discharge pressure error.
	Coils in contactor are burnt out.	Replace damaged assembly.
	Wrong connection of phase sequence.	Re-connect and adjust the any 2 wires among 3 phases.
	Water system error and flow type volume controller short connection.	Check water system.
	Error signal delivered from wired controller.	Find out the error type and carry out the corresponding measure to settle.
Air side heat exchanger excessive frost.	4-way valve or thermal resistor error.	Check the running state. Replace a new one if necessary.
	Air loop short-circuit.	Settle the short-circuit of air discharge.
With noise.	Fixing screws at panel are loosen.	Fix up all assemblies.

10.3 Typical malfunction solutions

1) High pressure and discharged temperature protection

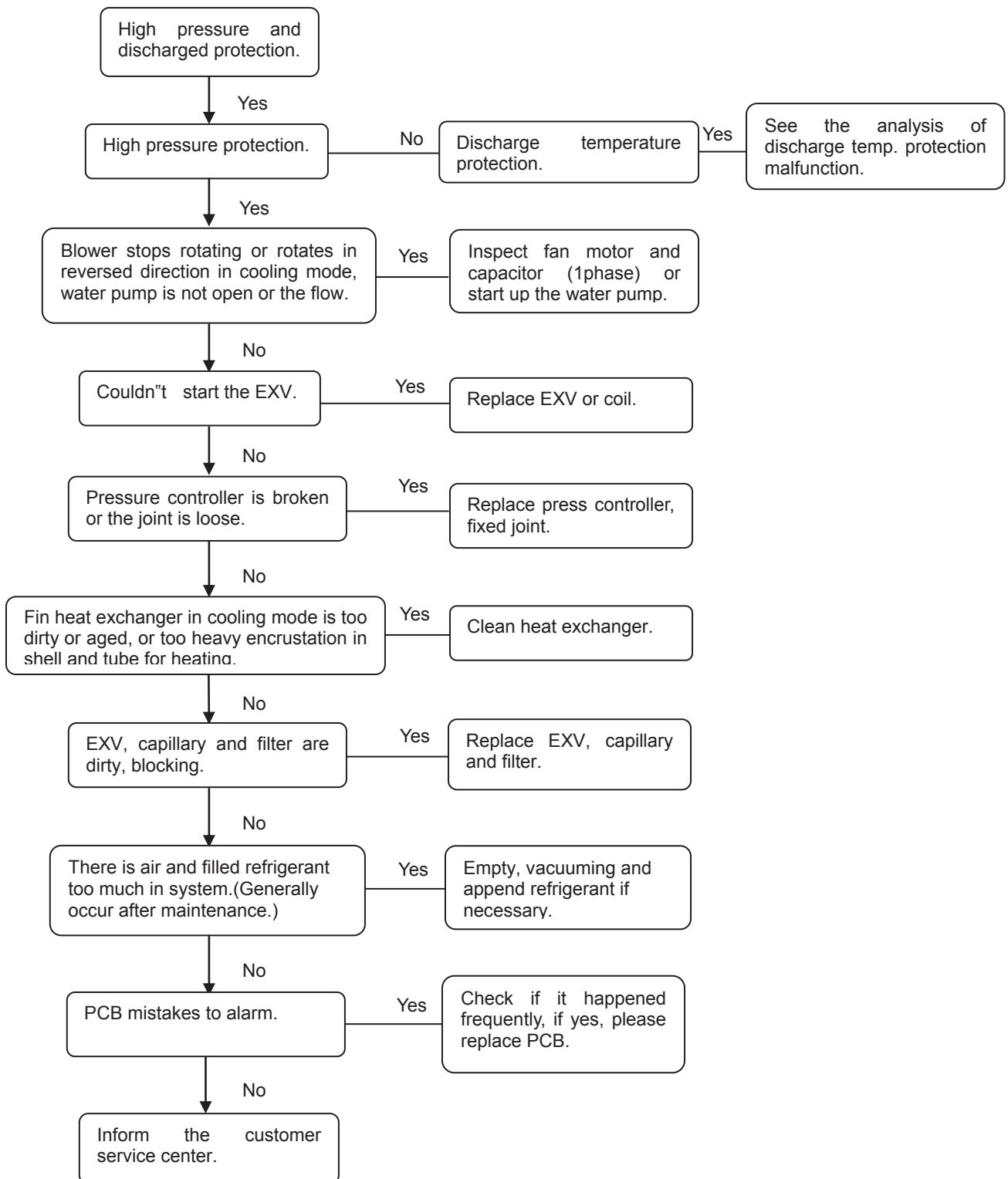

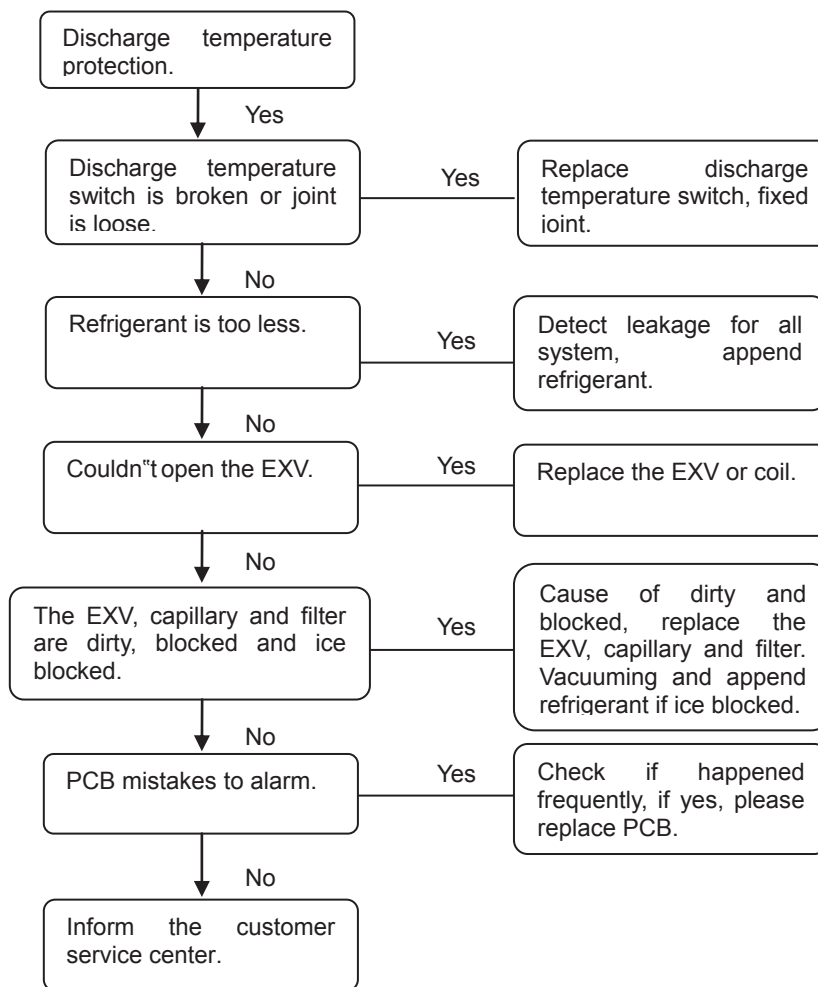

2) Low pressure protection

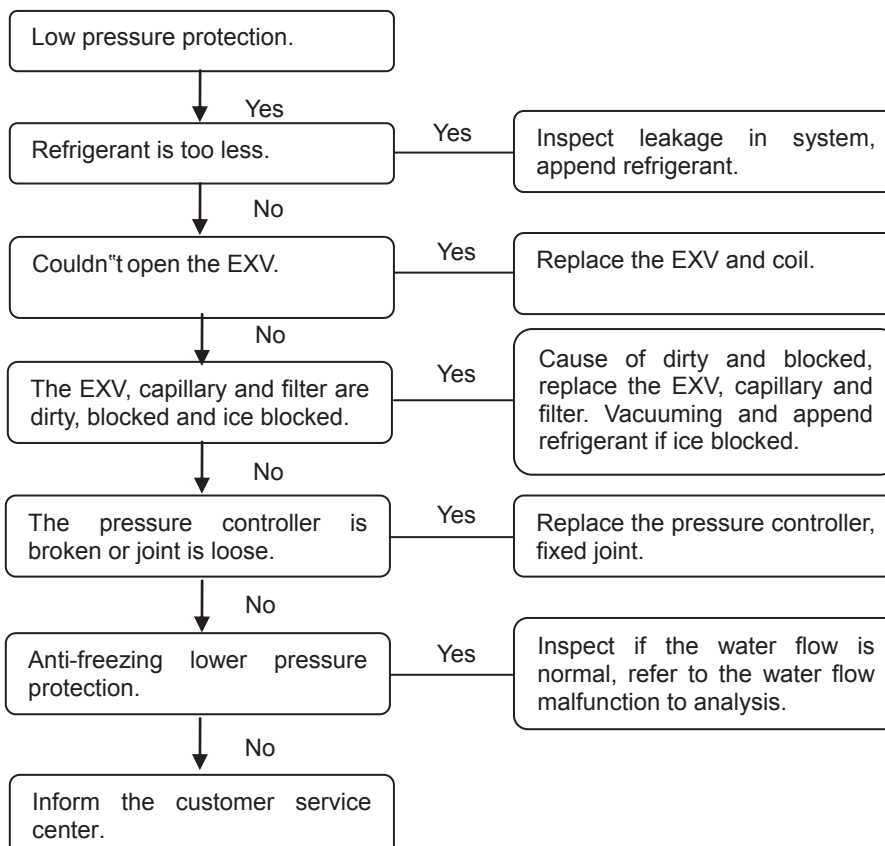

2) Current protection

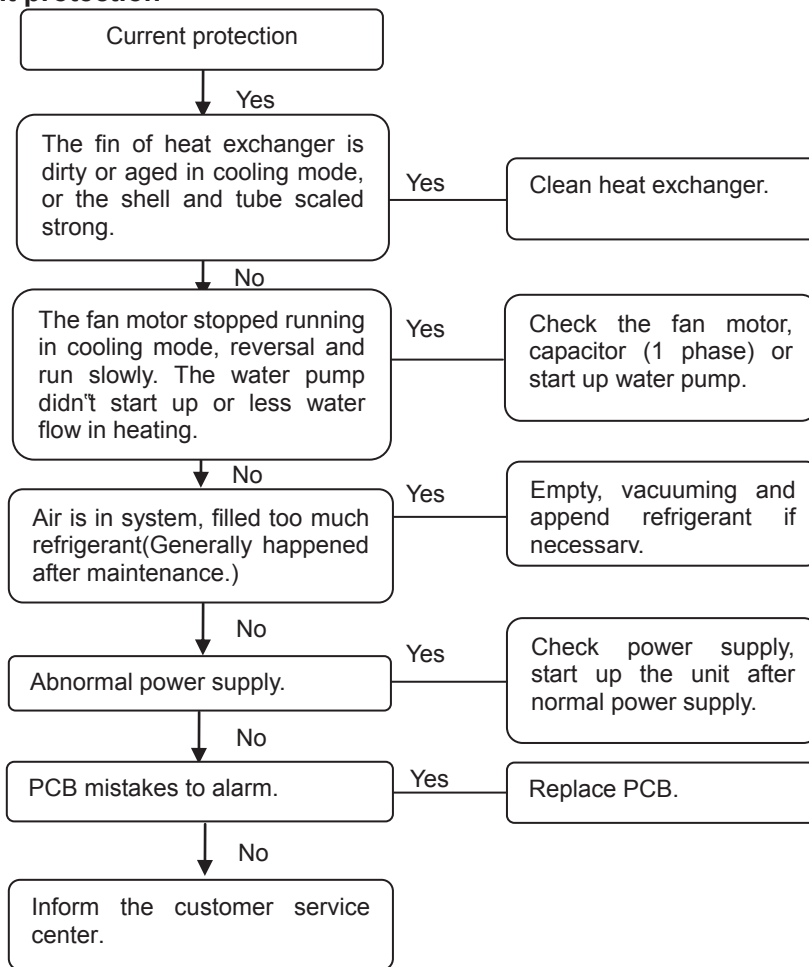

3) High temperature protection of condenser

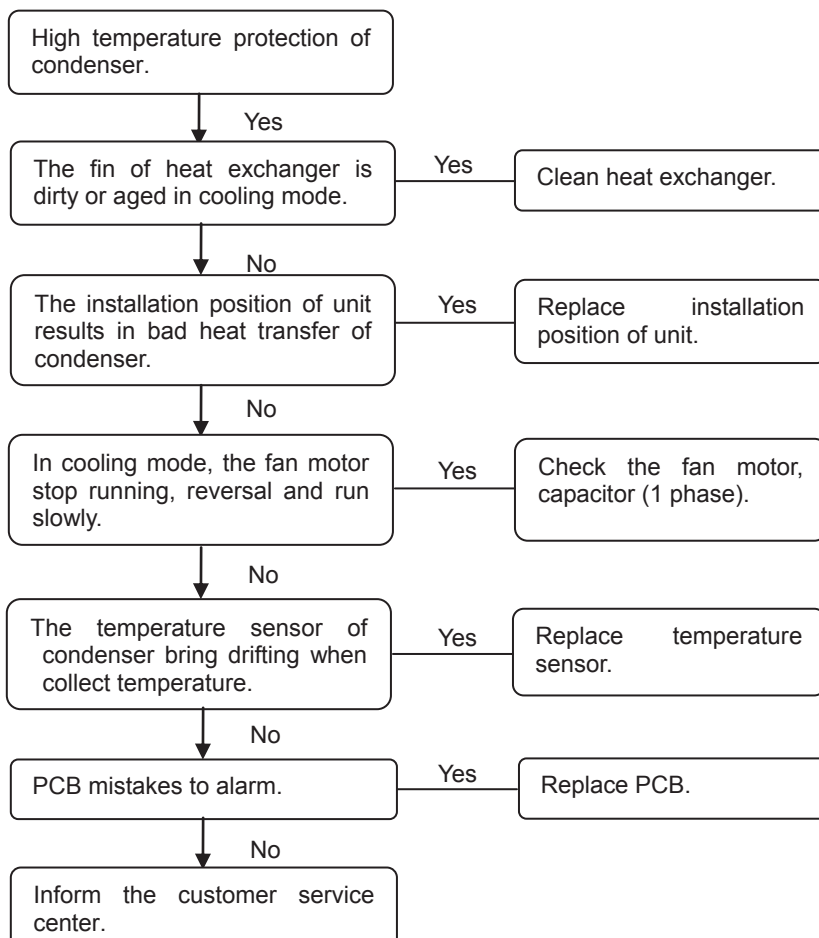

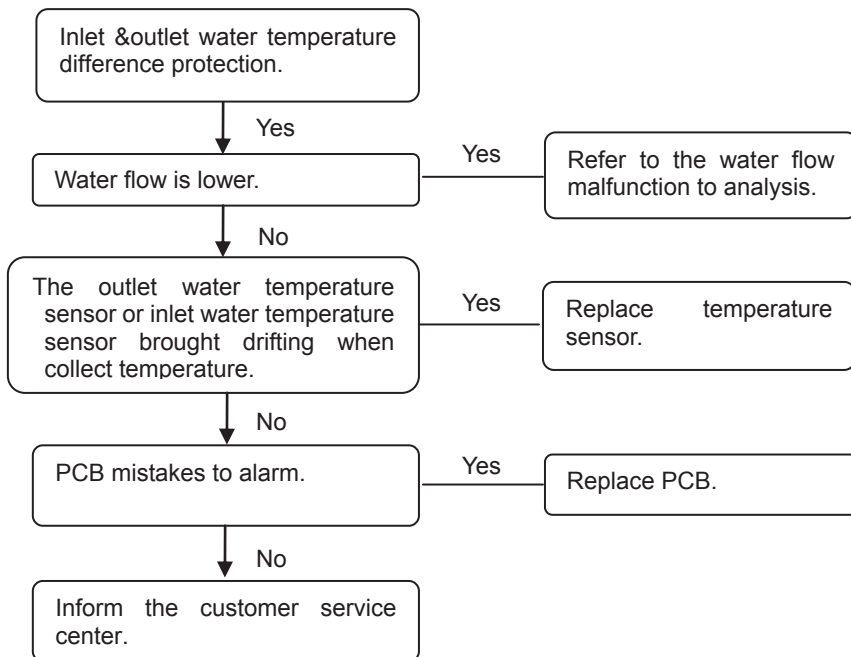
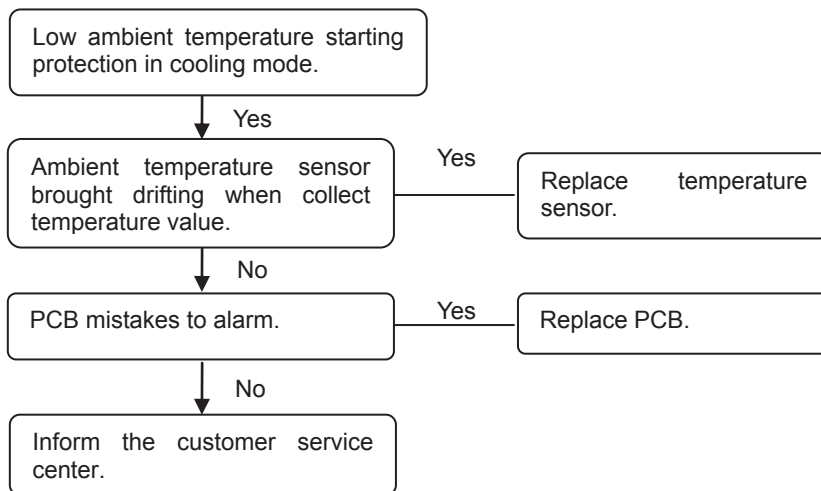
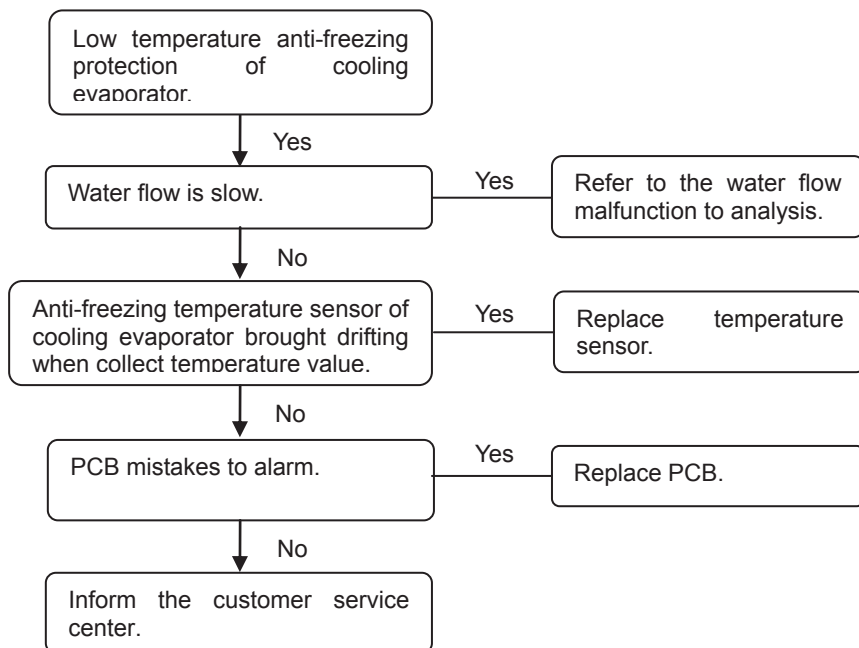
4) Inlet & outlet water temperature difference protection**5) Low ambient temperature starting up protection****6) Low temperature anti-freezing protection of cooling evaporator**

7) Power supply phase sequence malfunction

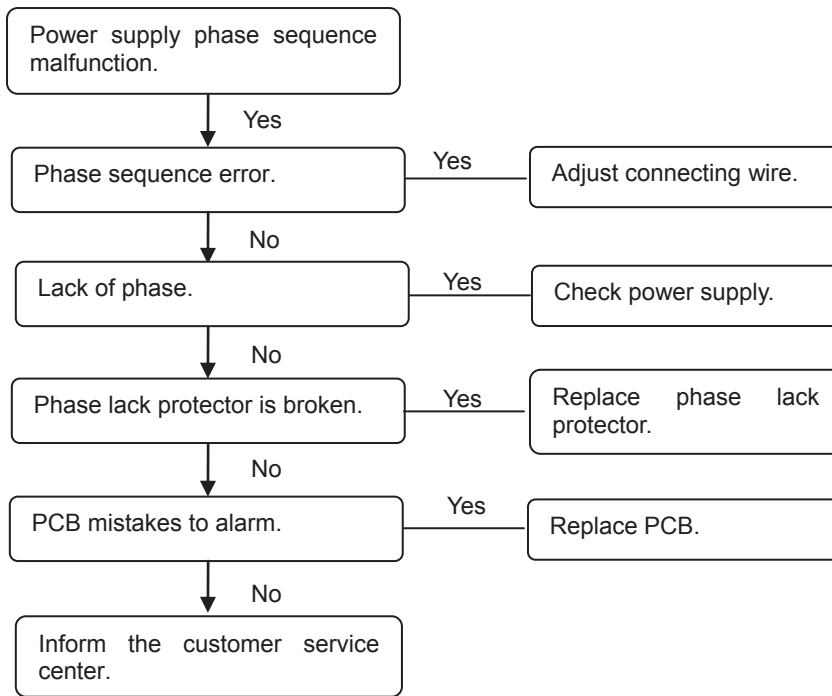

8) Communication malfunction

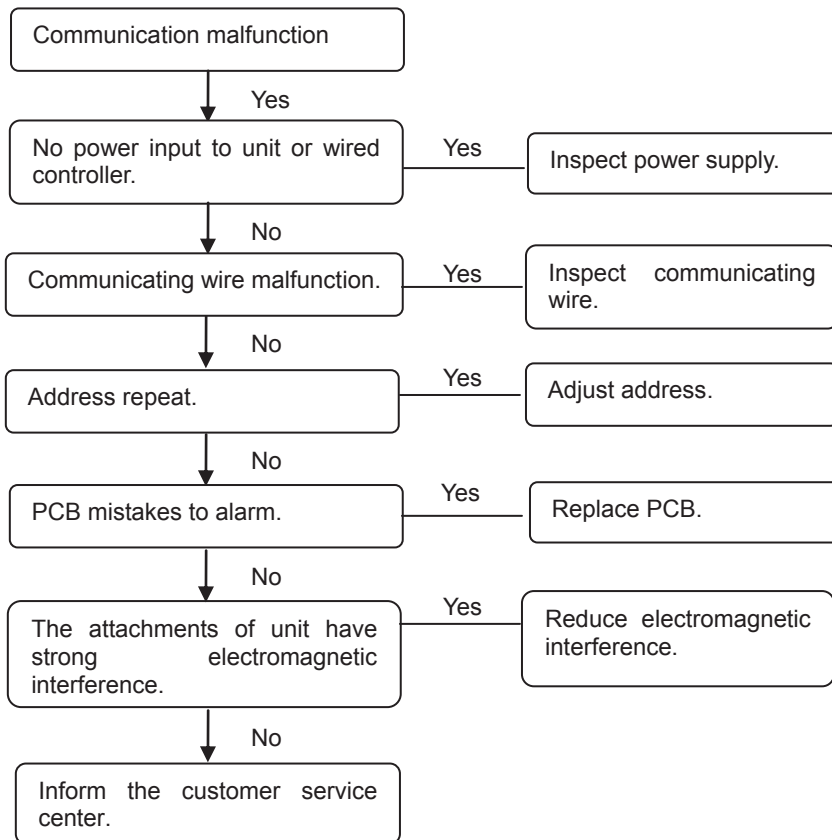

9) Water flow detection malfunction

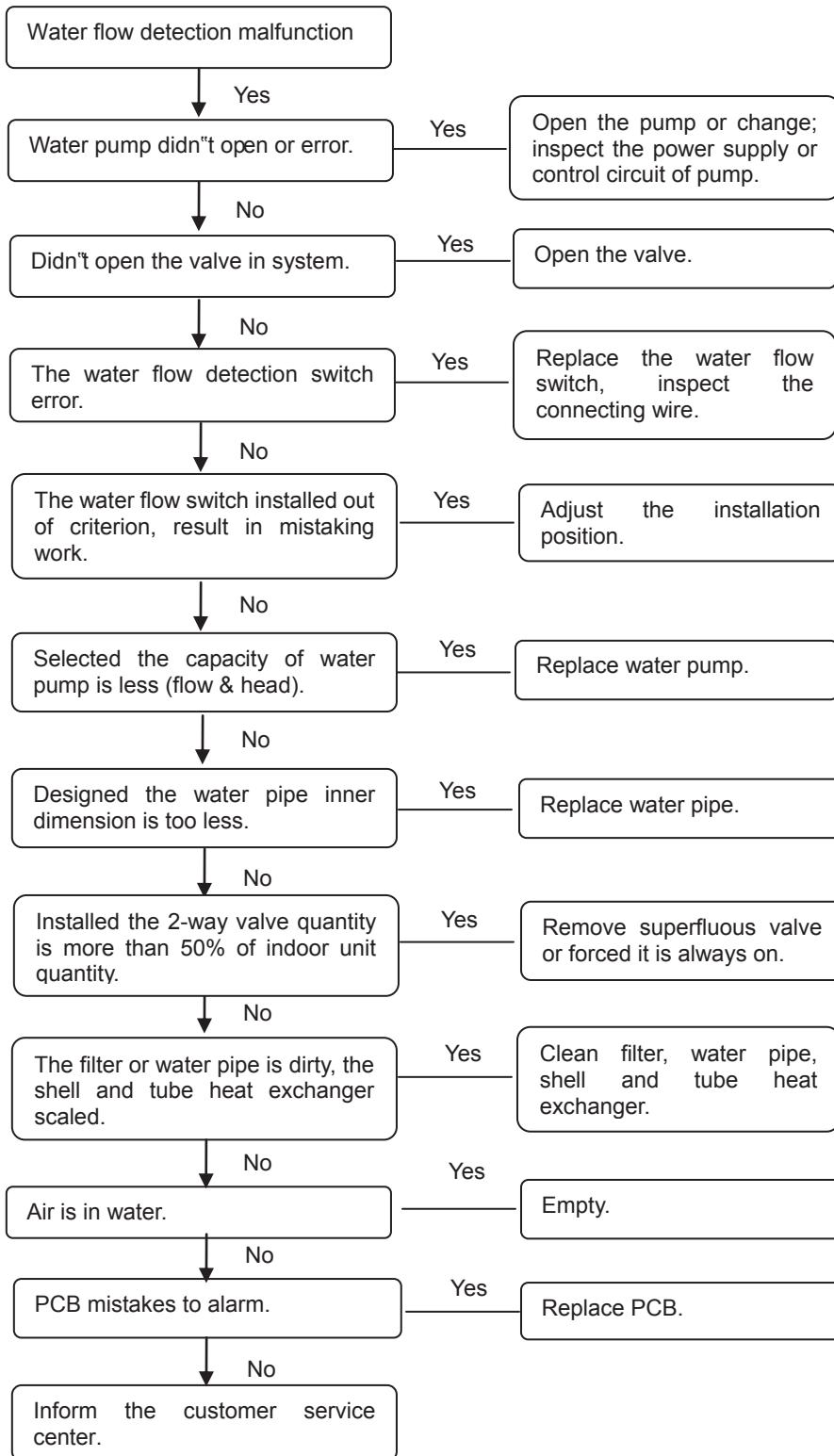

10) Total outlet water temperature sensor malfunction

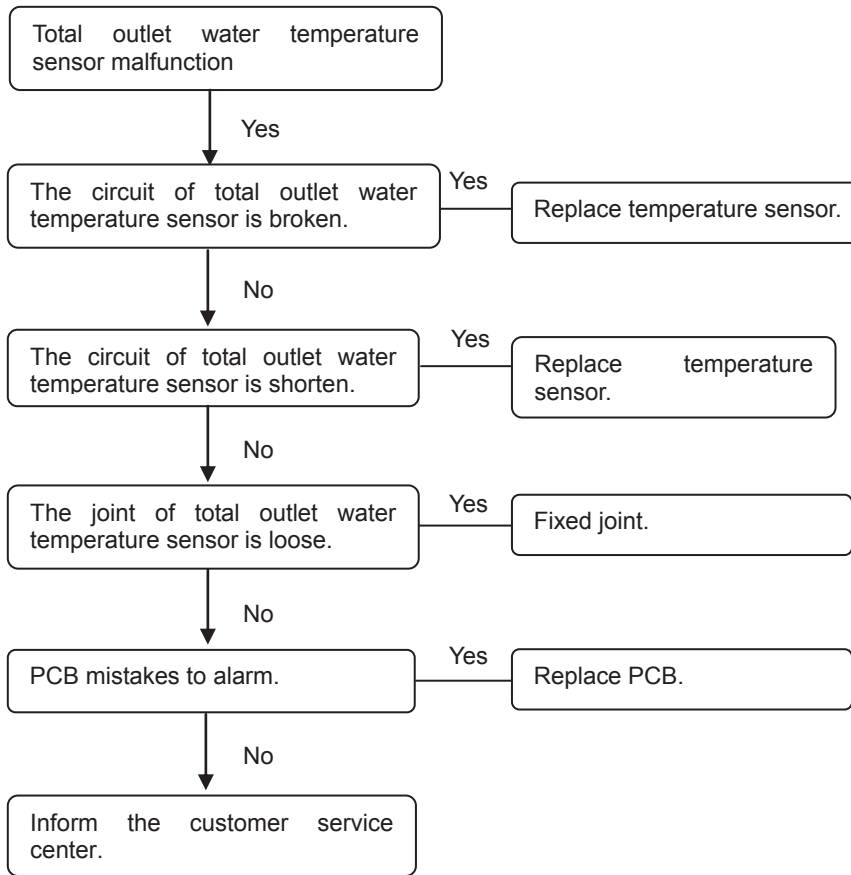

11) The unit outlet water temp. sensor malfunction

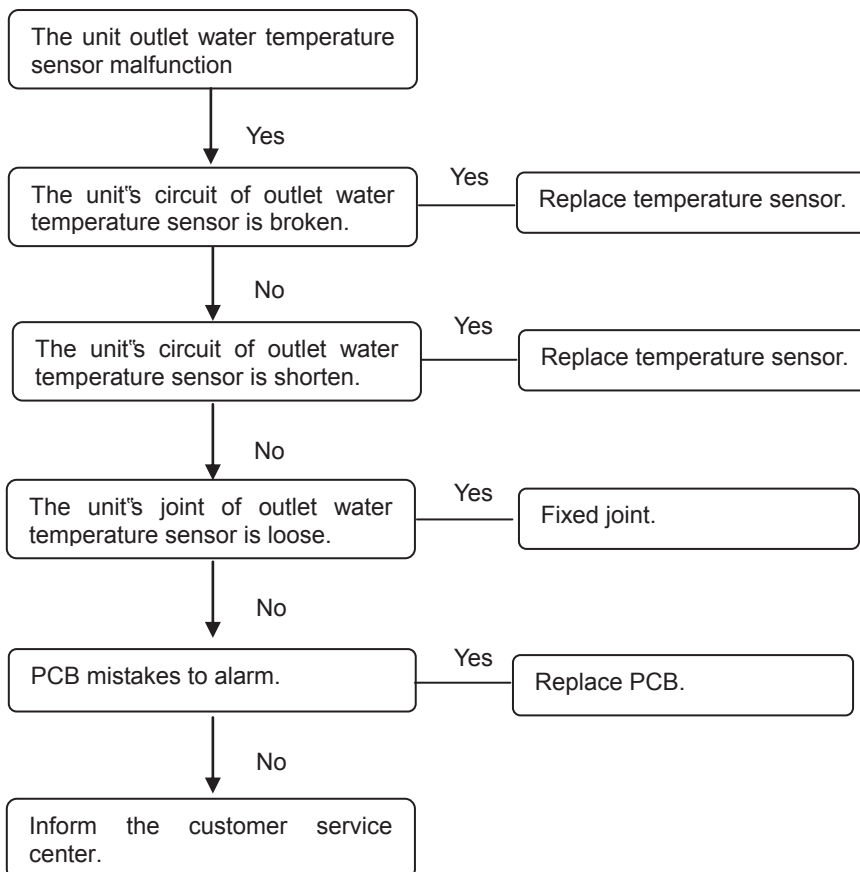

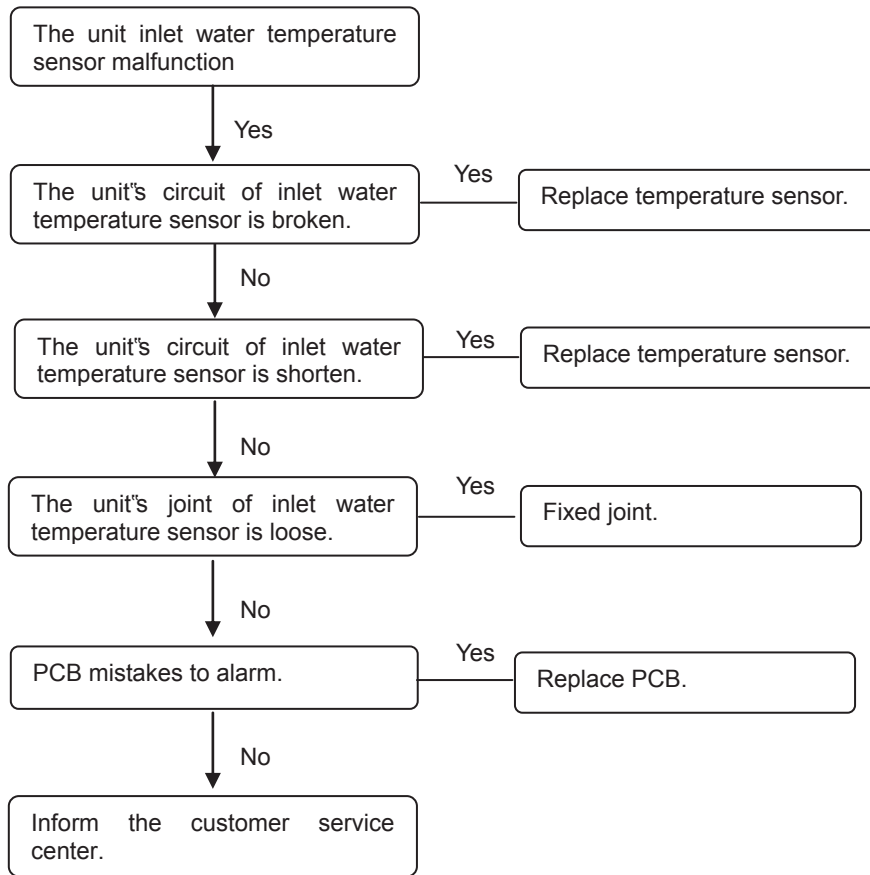
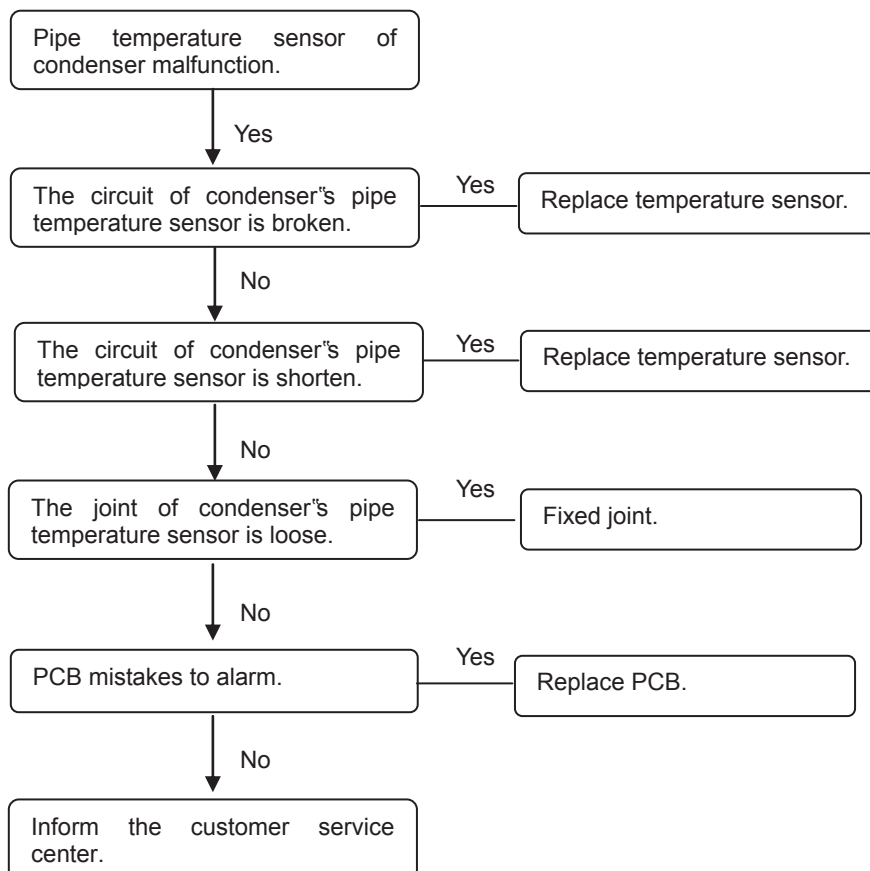
12) The unit inlet water temperature sensor malfunction**13) Pipe temp. sensor of condenser malfunction**

14) Ambient temperature sensor malfunction

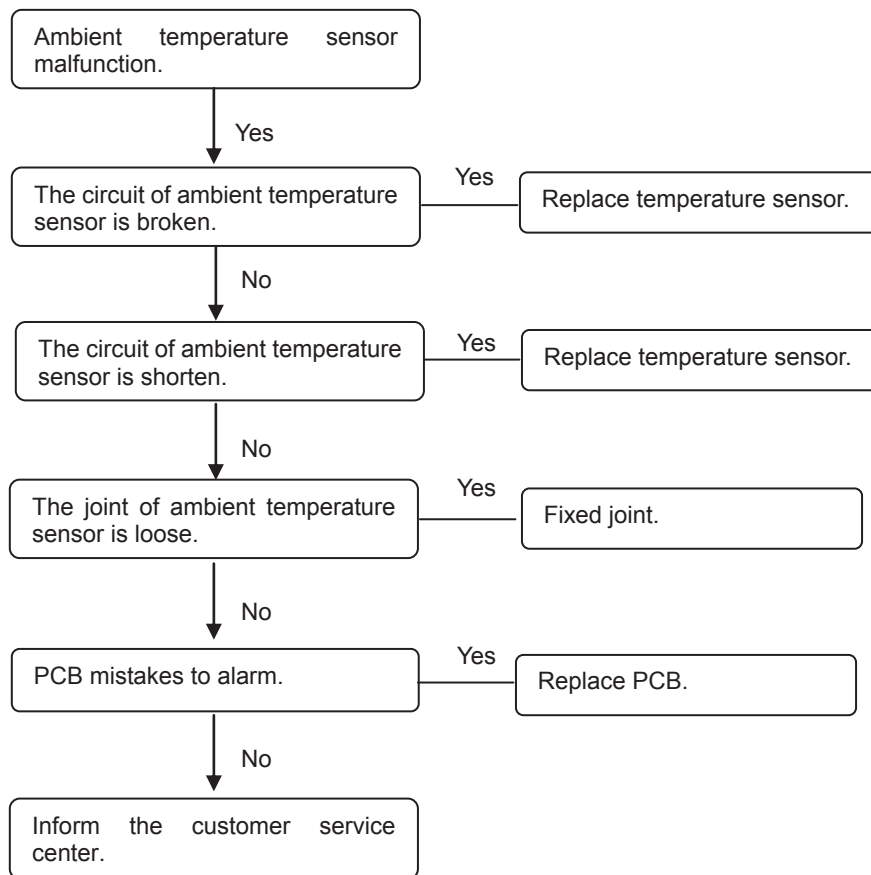

11 Installation

11.1 Unit Installation

11.1.1 Transportation

The angle of inclination should not be more than 15° when carrying the unit, to avoid overturn of the unit.

- Rolling handling: several rolling rods of the same size are placed under the base of the unit, and the length of each rod must be more than the outer frame of the base and suitable for balancing of the unit.
- Lifting: the strength lifting rope (belt) can bear should be 4 times the weight of the unit. Check the lifting hook and ensure that it is firmly attached to the unit, and the lifting angle should be more than 60° . To avoid damages to the unit, the contact position of the unit and lifting rope should be provided with an at least 50mm thick wood block, cloth or hard paper.

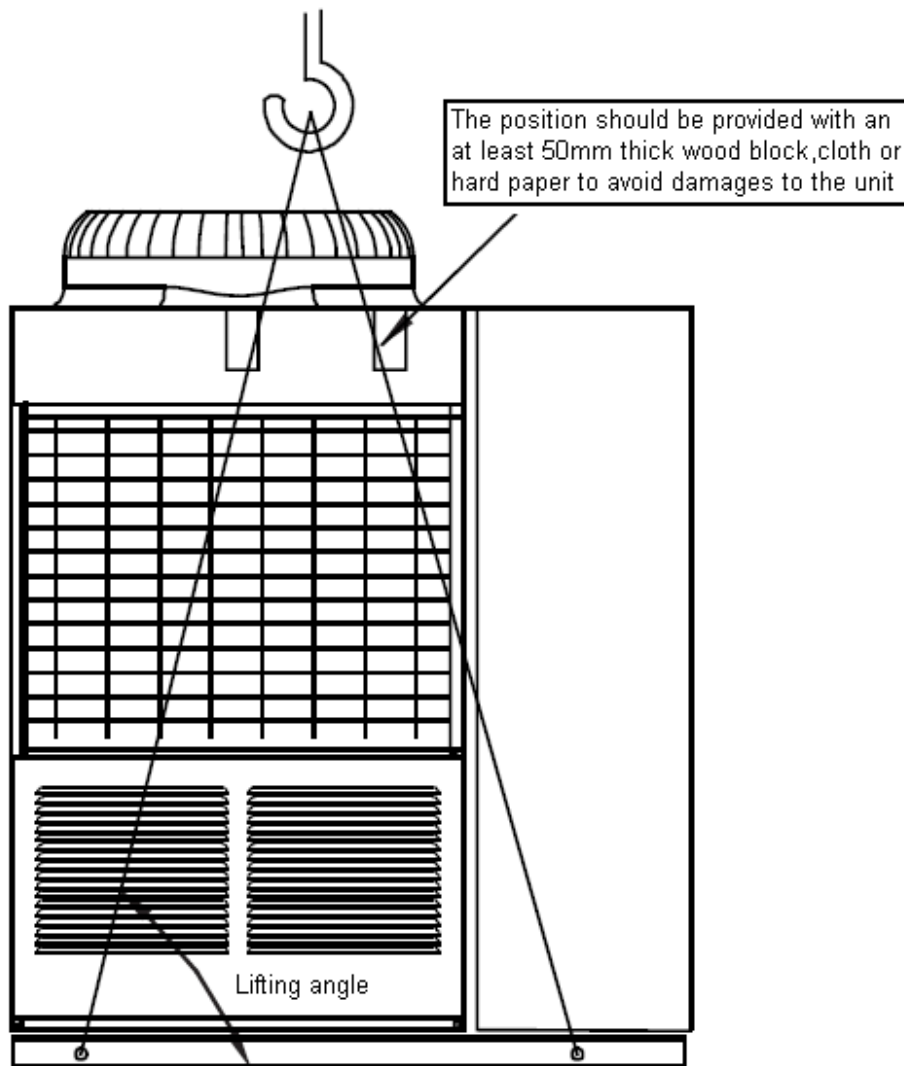

30kW module

Handling of the unit

The angle of inclination should not be more than 15° when carrying the unit, to avoid overturn of the unit.

- Rolling handling: several rolling rods of the same size are placed under the base of the unit, and the length of each rod must be more than the outer frame of the base and suitable for balancing of the unit.
- Lifting: the strength lifting rope (belt) can bear should be 4 times the weight of the unit. Check the lifting hook and ensure that it is firmly attached to the unit. To avoid damages to the unit, the contact position of the unit and lifting rope should be provided with an at least 50mm thick wood block, cloth or hard paper. Any person is not allowed to stand below the unit when lifting it.

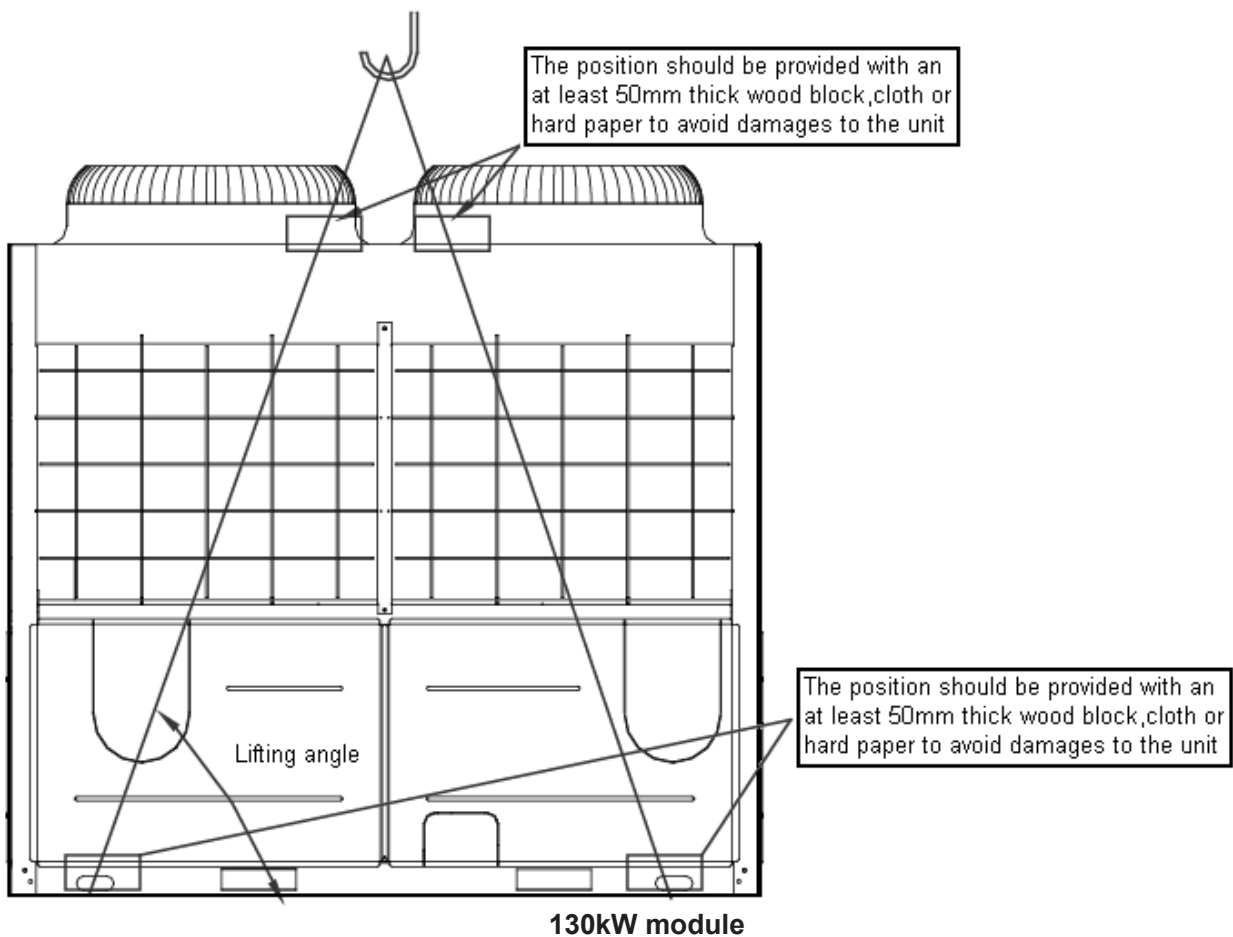
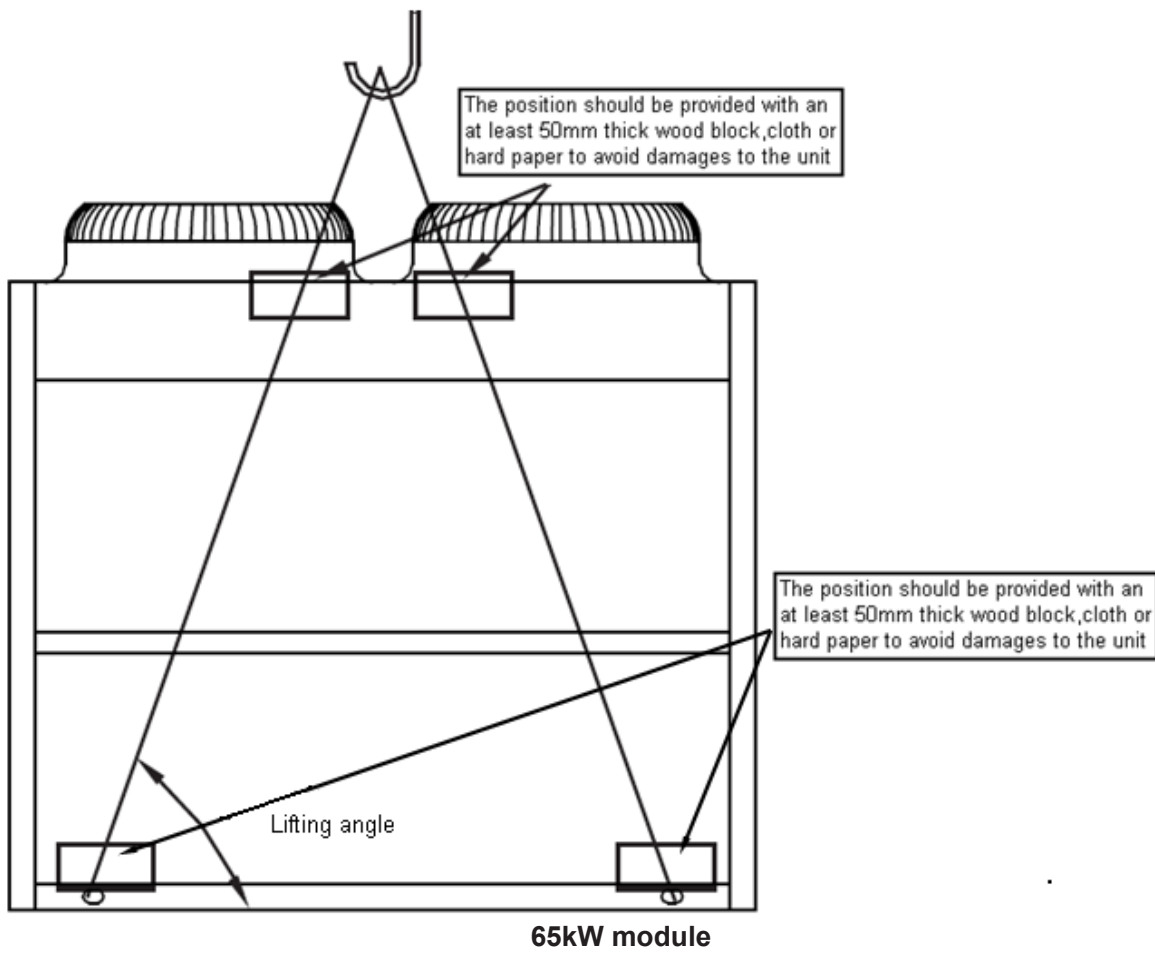

185kW module

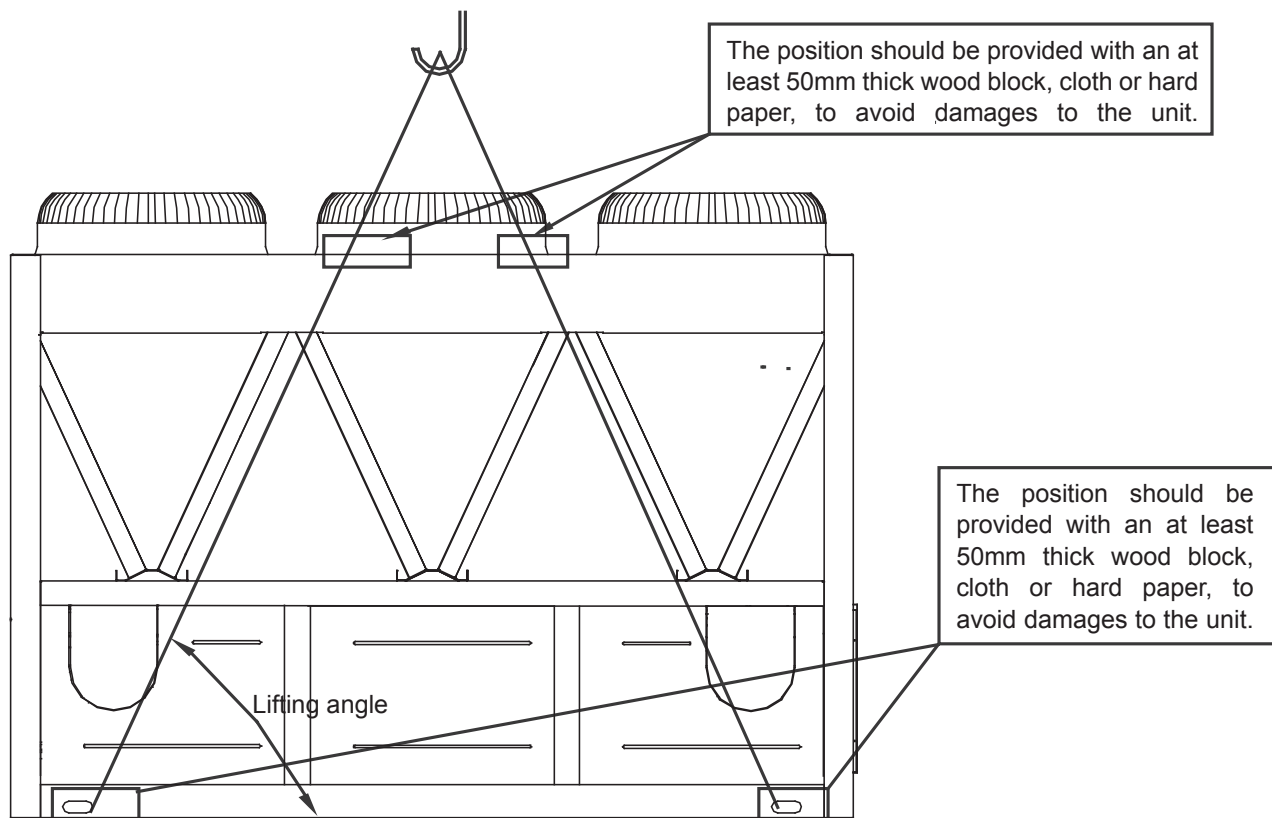
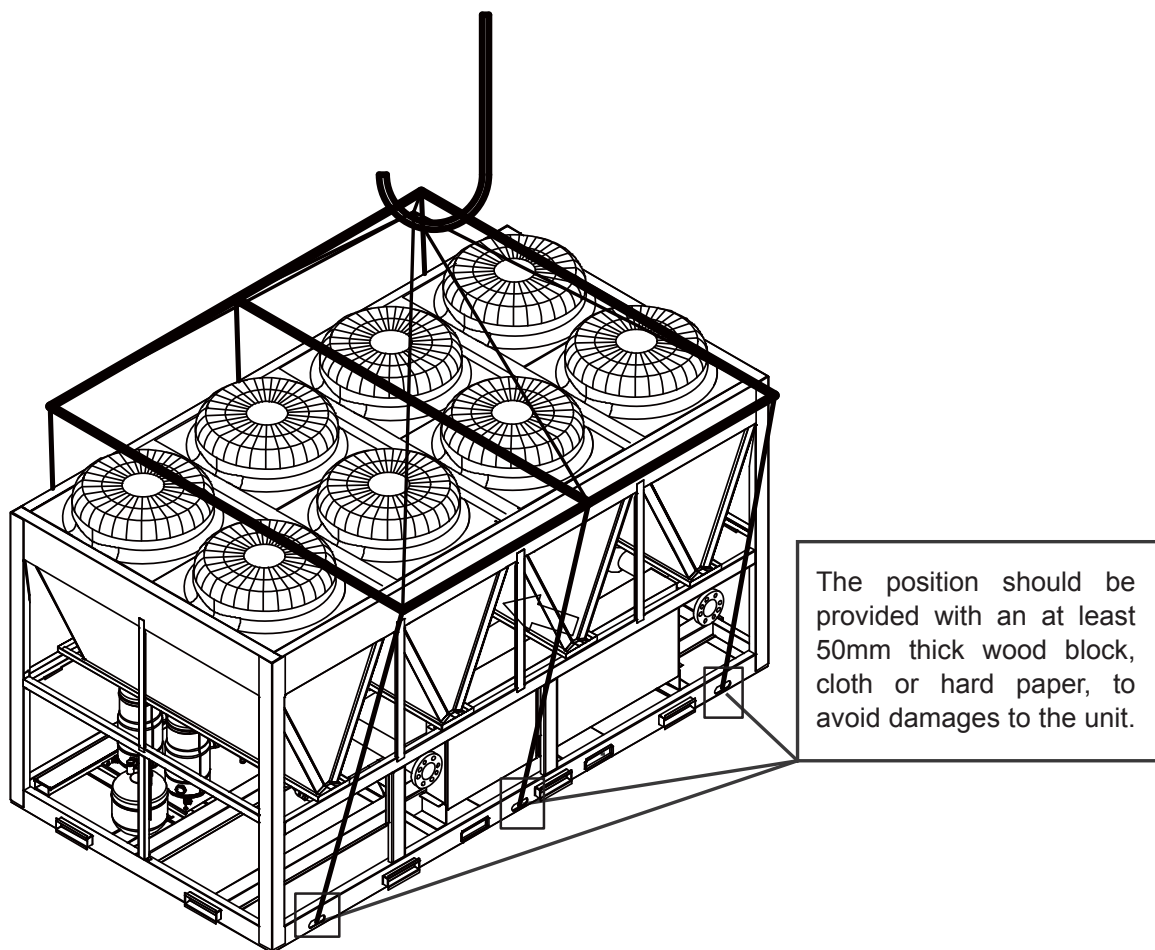

Fig. 2-1 Lifting of the unit

250kW module



11.1.2 Installation space

• Requirements of arrangement space of the unit

- 1) To ensure adequate airflow entering the condenser, the influence of descending airflow caused by the high-rise buildings around upon the unit should be taken into account when installing the unit.
- 2) If the unit is installed where the flowing speed of air is high, such as on the exposed roof, the measures including sunk fence and Persian blinds can be taken, to prevent the turbulent flow from disturbing the air entering the unit. If the unit needs to be provided with sunk fence, the height of the latter should not be more than that of the former; if Persian blinds are required, the total loss of static pressure should be less than the static pressure outside the fan. The space between the unit and sunk fence or Persian blinds should also meet the requirement of the minimum installation space of the unit.
- 3) If the unit needs to operate in winter, and the installation site may be covered by snow, the unit should be located higher than the snow surface, to ensure that air flows through the coils smoothly.

30kW module

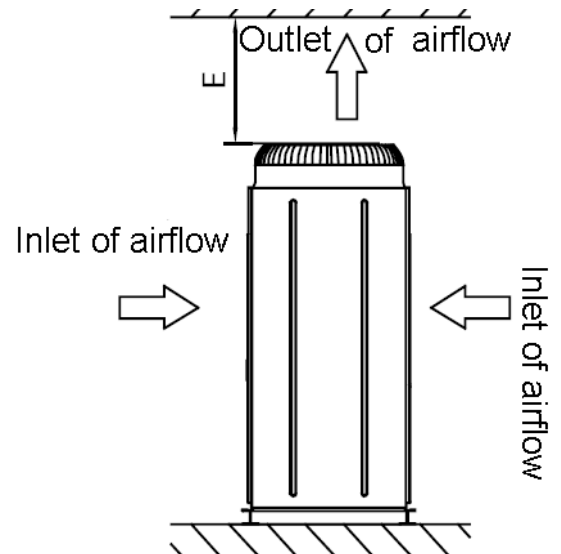
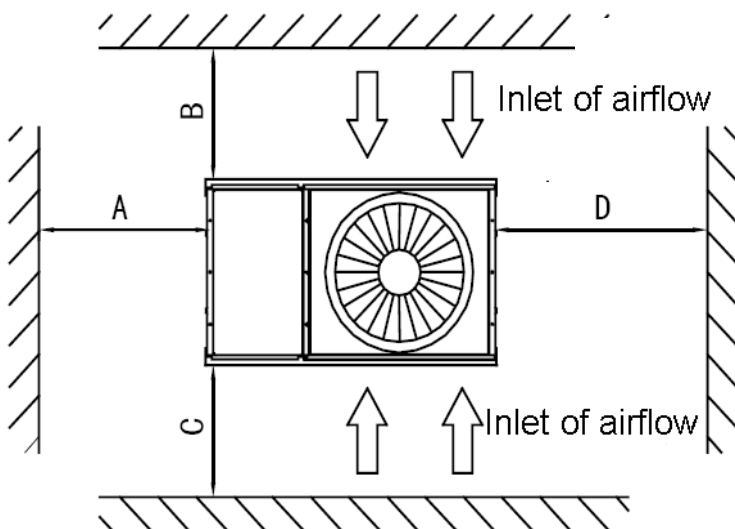

65kW module

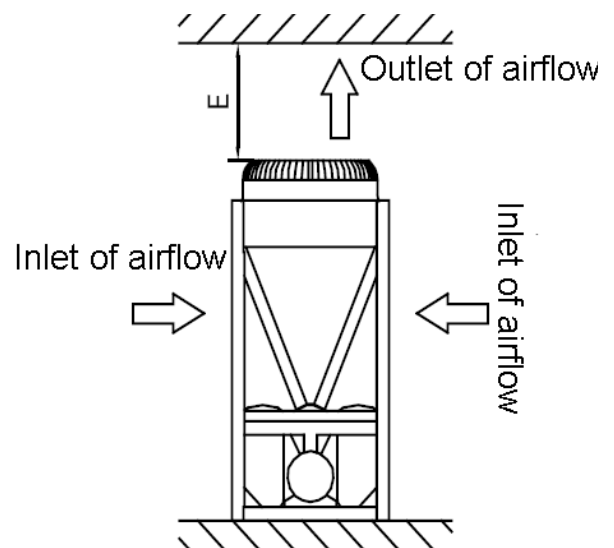
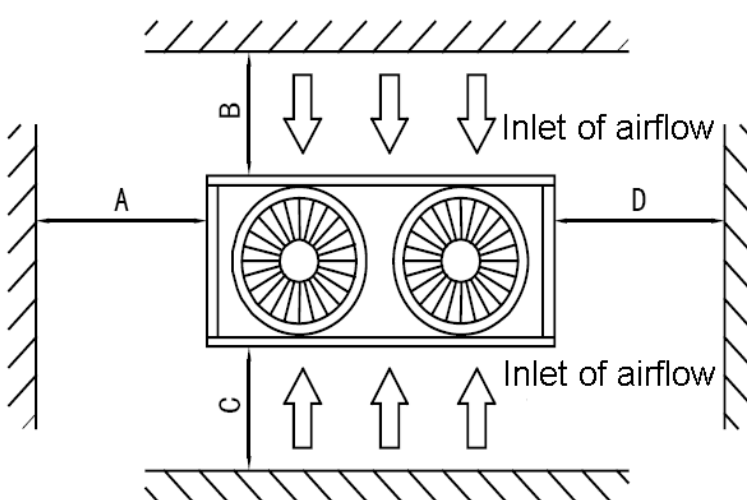

130kW module

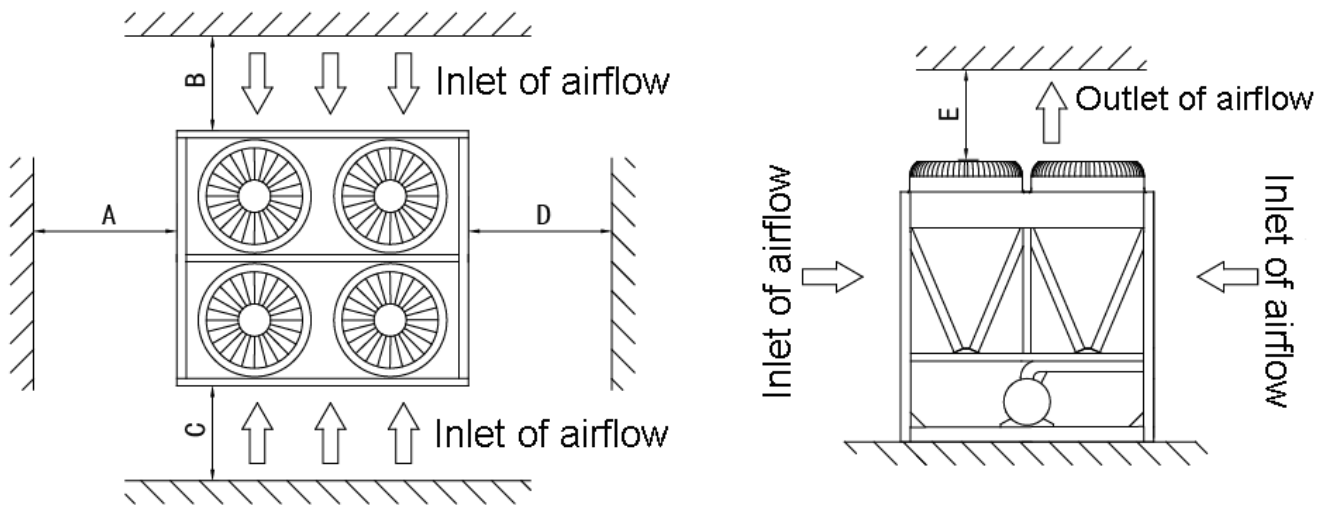

185kW module

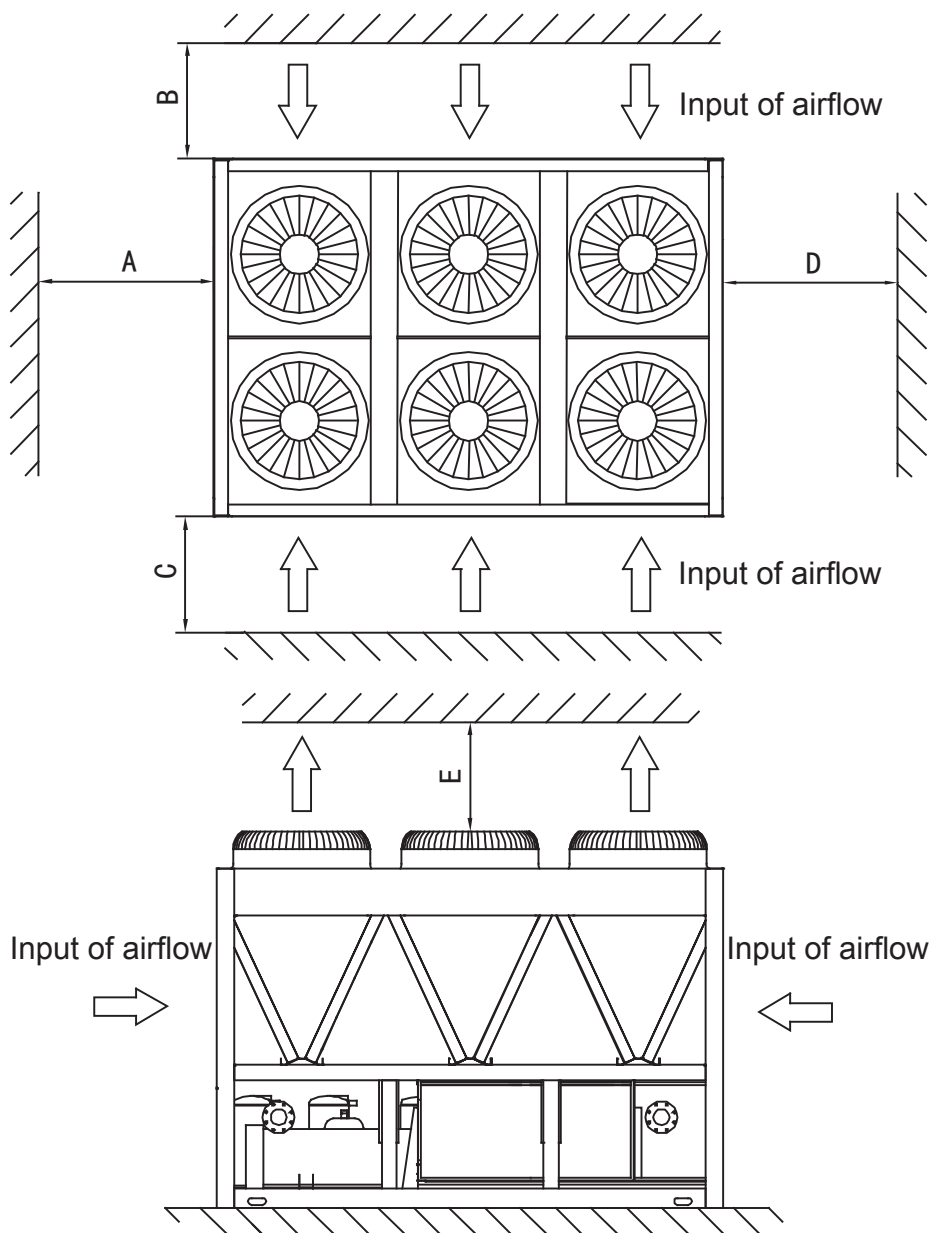

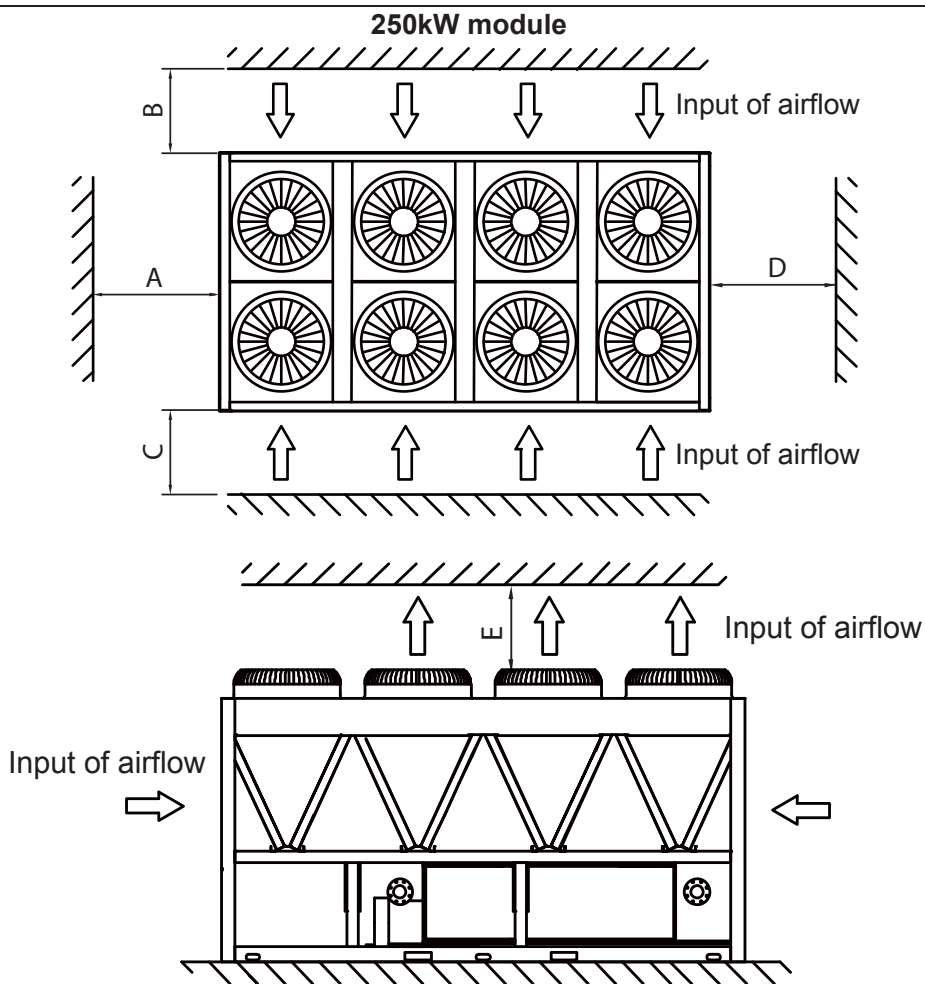

The recommend space parameter

Module	Installation space (mm)				
	A	B	C	D	E
MCCH30A-TA3SL	≥1500	≥2000	≥2000	≥1500	≥8000
MCDH30A-TA3SL					
MCCH65A-SA3L					
MCDH65A-SA3L					
MCCH130A-SA3L				≥2000	
MCCH185A-SA3					
MCCH250A-SA3T	≥2000				

Space requirements for parallel installation of multiple modular units.

To avoid back flow of the air in the condenser and operational faults of the unit, the parallel installation of multiple modular units can follow the direction A and D as shown in the figure above, the spaces between the unit and the obstacle are given in the figure above, and the space between adjacent modular units should not be less than 300mm; the installation can also follow the direction B and C as shown in the figure above, the spaces between the unit and the obstacle are given in the figure above, and the space between adjacent modular units should not be less than 600mm; the installation can also follow the direction combination of A and D, and B and C, the spaces between the unit and the obstacle are given in the figure above, the space between adjacent modular units in the direction A and D should not be less than 300mm, and the space between adjacent modular units in the direction B and C should not be less than 600mm.

If the spaces mentioned above cannot be met, the air passing from the unit to the coils may be restricted, or back flow of air discharge may occur, and the performance of the unit may be affected, or the unit may fail to operate.

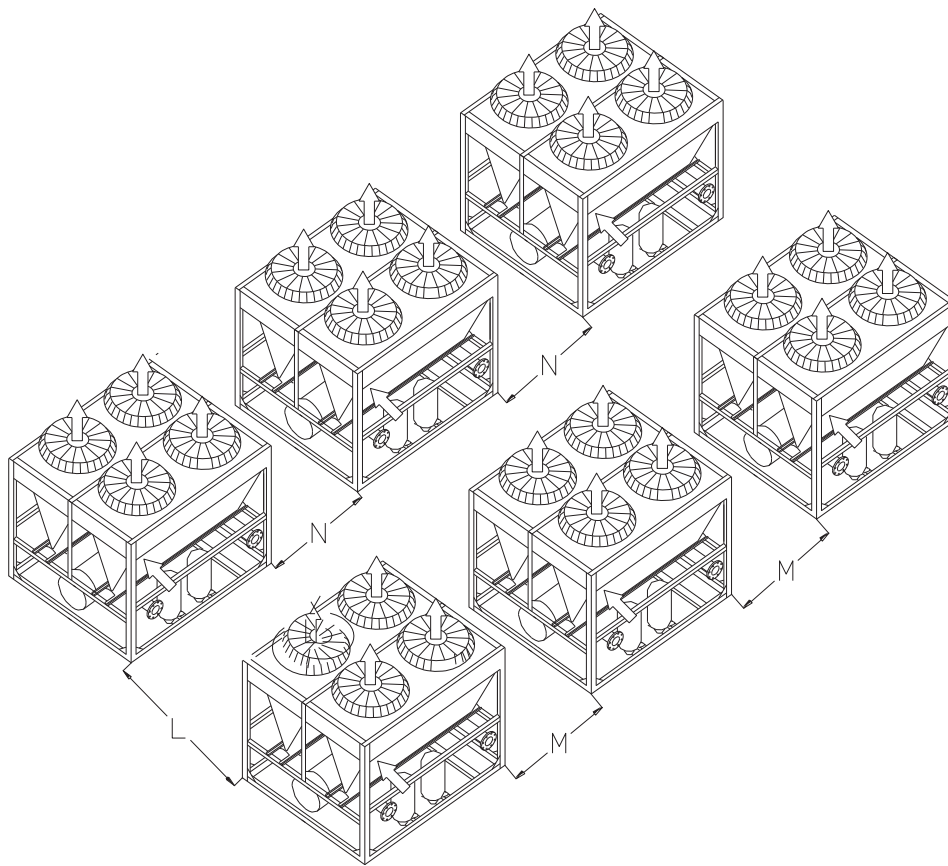

No	Model	Max unit combined quantity	L(mm)	M(mm)	N(mm)
1	MCCH30A-TA3SL	1	≥600	≥300	≥300
2	MCDH30A-TA3SL	1	≥600	≥300	≥300
3	MCCH65A-SA3L	16	≥600	≥300	≥300
4	MCCD65A-SA3L	16	≥600	≥300	≥300
5	MCCH130A-SA3L	8	≥600	≥300	≥300
6	MCCH185A-SA3	5	≥600	≥300	≥300
7	MCCH250A-SA3T	8	≥600	≥300	≥300

11.1.3 Installation Foundation

- The unit should be located on the horizontal foundation, the ground floor or the roof which can bear operating weight of the unit and the weight of maintenance personnel. Refer to the operating weight parameters in specification table.
- If the unit is located so high that it is inconvenient for maintenance personnel to conduct maintenance, the suitable scaffold can be provided around the unit.
- The scaffold must be able to bear the weight of maintenance personnel and maintenance facilities.
- The bottom frame of the unit is not allowed to be embedded into the concrete of installation foundation.

Location drawing of installation foundation of the unit (unit: mm)

30kW module

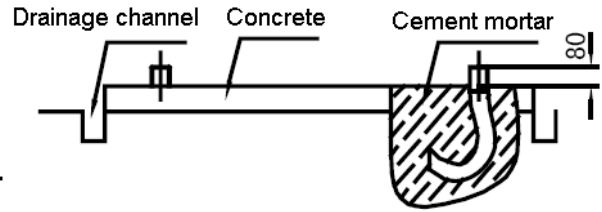
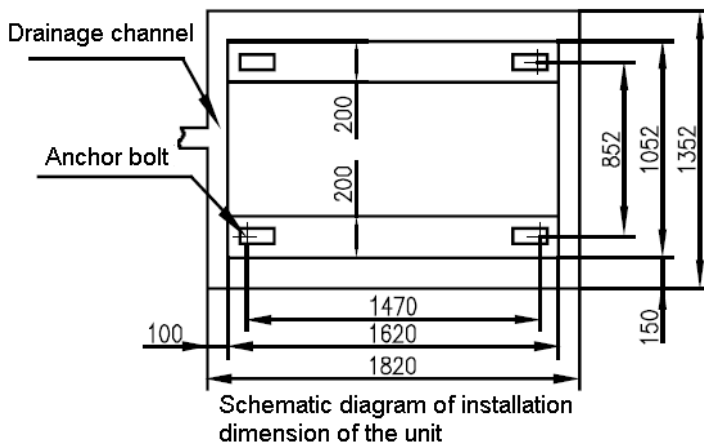

65kW module

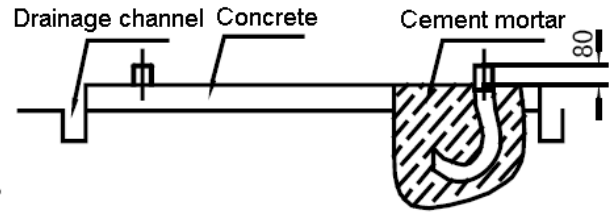
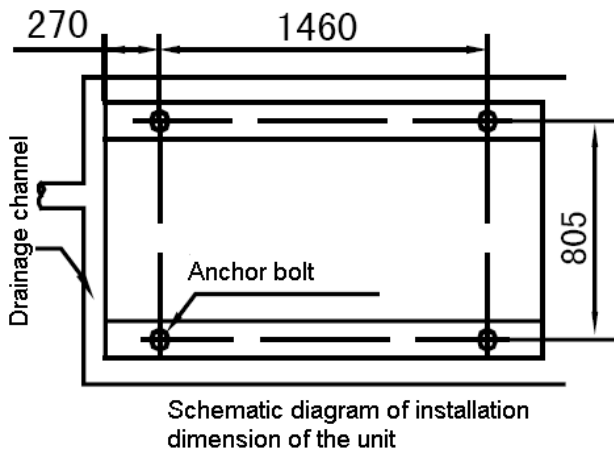

130kW module

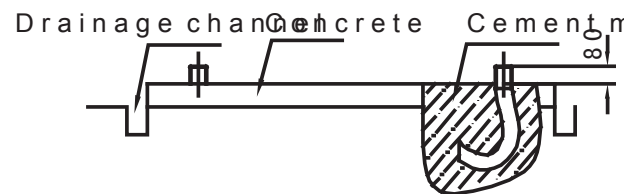
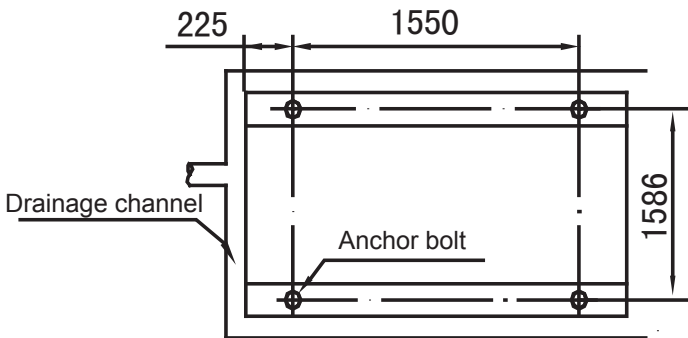

185 kW module

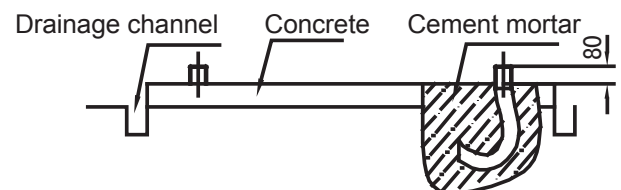
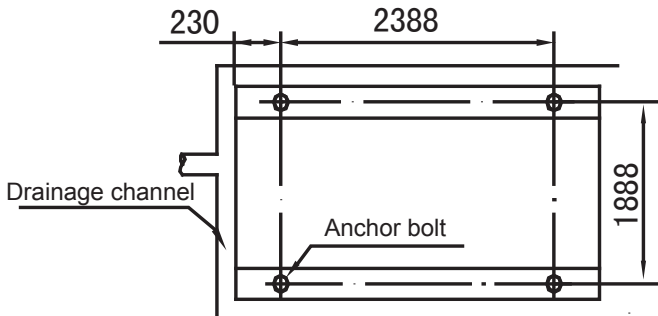

250kW module

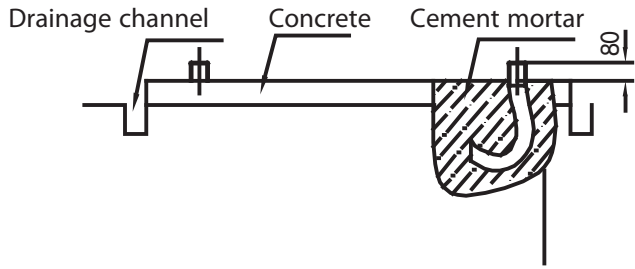
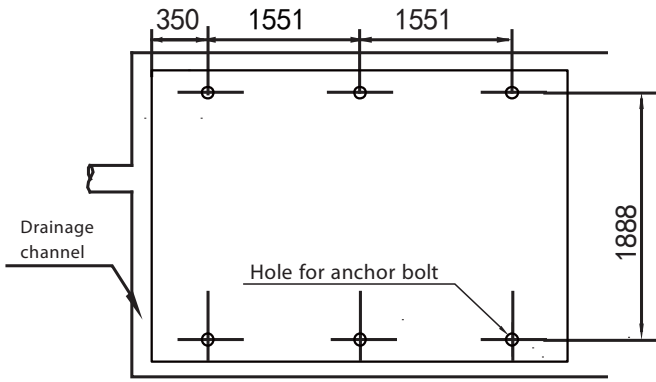

Schematic diagram of nstallation dimension of the unit

Load distribution

Unit: kg

No	Model	R1	R2	R3	R4	R5	R6
1	MCCH30A-TA3SL	90	77	157	131	/	/
2	MCDH30A-TA3SL	90	77	157	131	/	/
3	MCCH65A-SA3L	170	180	145	155	/	/
4	MCDH65A-SA3L	170	180	145	155	/	/
5	MCCH130A-SA3L	350	340	295	285	/	/
6	MCCH185A-SA3	567	433	567	433	/	/
7	MCCH250A-SA3T	373	344	487	462	539	395

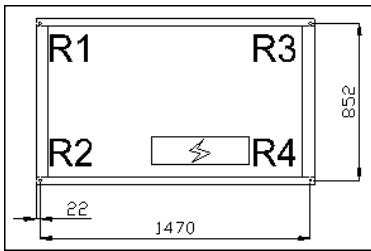

30KW

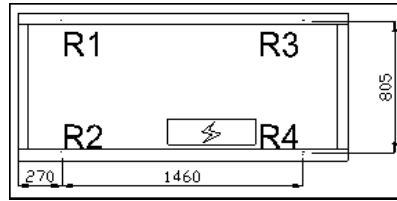

65KW

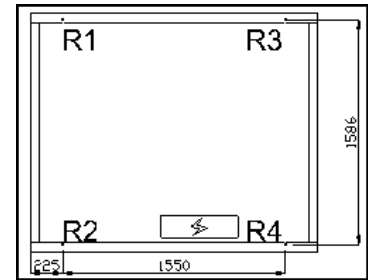

130KW

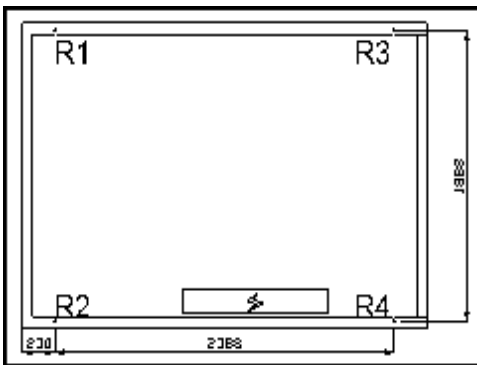

185 KW

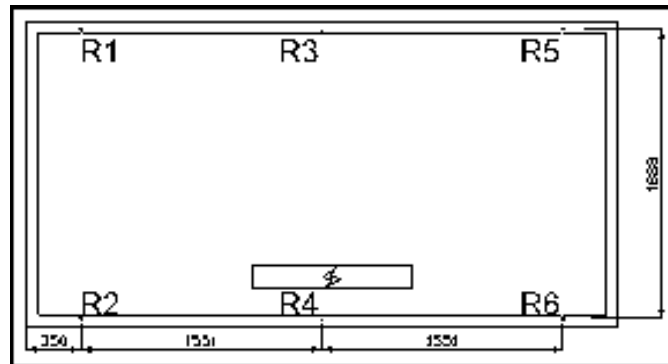

250KW

11.4 Installation of damping devices

※ Damping devices must be provided between the unit and its foundation.

By means of the $\Phi 15\text{mm}$ diameter installation holes on the steel frame of the unit base, the unit can be fastened on the foundation through the spring damper. See *figure above* (Schematic diagram of installation dimension of the unit) for details about center distance of the installation holes. The damper does not go with the unit, and the user can select the damper according to the relevant requirements. When the unit is installed on the high roof or the area sensitive to vibration, please consult the relevant persons before selecting the damper.

※ Installation steps of the damper

Step	Content
1	Make sure that the flatness of the concrete foundation is within $\pm 3\text{mm}$, and then place the unit on the cushion block.
2	Raise the unit to the height suitable for installation of the damping device. Remove the clamp nuts of the damper.
3	Place the unit on the damper, and align the fixing bolt holes of the damper with the fixing holes on the unit base.
4	Return the clamp nuts of the damper to the fixing holes on the unit base, and tighten them into the damper.
5	Adjust the operational height of the damper base, and screw down the leveling bolts. Tighten the bolts by one circle to ensure equal height adjustment variance of the damper.
6	The lock bolts can be tightened after the correct operational height is reached.

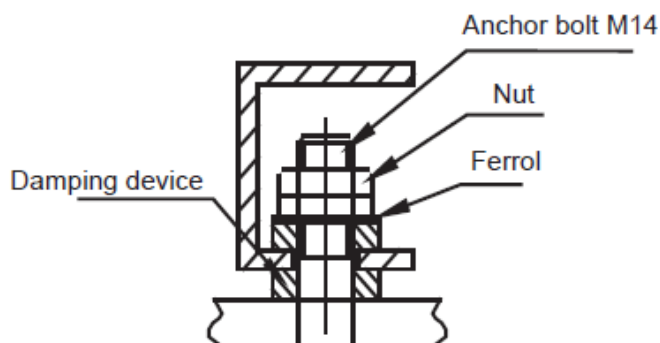

11.2 Water System Installation

Notice:

- After the unit is in place, chilled water pipes can be laid.
- The relevant installation regulations should be abided with when conducting connection of water pipes.
- The pipelines should be free of any impurity, and all chilled water pipes must conform to local rules and regulations of pipeline engineering.

11.2.1 Connection requirements of chilled water pipes

- a. All chilled water pipelines should be thoroughly flushed, to be free of any impurity, before the unit is operated. Any impurity should not be flushed to or into the heat exchanger.
- b. Water must enter the heat exchanger through the inlet; otherwise the performance of the unit will decline.
- c. The inlet pipe of the evaporator must be provided with a target flow controller, to realize flow-break protection for the unit. Both ends of the target flow controller must be supplied with horizontal straight pipe sections whose diameter is 5 times that of the inlet pipe. The target flow controller must be installed in strict accordance with "Installation & Regulation Guide for Target Flow Controller". The wires of the target flow controller should be led to the electric cabinet through shielded cable. The working pressure of the target flow controller is 1.0MPa, and its interface is 1 inch in diameter. After the pipelines are installed, the target flow controller will be set properly according to the rated water flow of the unit.

- d. The pump installed in the water pipeline system should be equipped with starter. The pump will directly press water into the heat exchanger of the water system.
- e. The pipes and their ports must be independently supported but should not be supported on the unit.
- f. The pipes and their ports of the heat exchanger should be easy to disassemble for operation and cleaning, as well as inspection of port pipes of the evaporator.
- g. The evaporator should be provided with a filter with more than 40 meshes per inch at site. The filter should be installed near to the inlet port as much as possible, and be under heat preservation.
- h. The by-pass pipes and by-pass valves as shown in the figure of “**Connection drawing of pipeline system**” must be mounted for the heat exchanger, to facilitate cleaning of the outside system of water passage before the unit is adjusted. During maintenance, the water passage of the heat exchanger can be cut off without disturbing other heat exchangers.
- i. The flexible ports should be adopted between the interface of the heat exchanger and on-site pipeline, to reduce transfer of vibration to the building.
- j. To facilitate maintenance, the inlet and outlet pipes should be provided with thermometer or manometer. The unit is not equipped with pressure and temperature instruments, so they need to be purchased by the user.
- k. All low positions of the water system should be provided with drainage ports, to drain water in the evaporator and the system completely; and all high positions should be supplied with discharge valves, to facilitate expelling air from the pipeline. The discharge valves and drainage ports should not be under heat preservation, to facilitate maintenance.
- l. All possible water pipes in the system to be chilled should be under heat preservation, including inlet pipes and flanges of the heat exchanger.
- m. The outdoor chilled water pipelines should be wrapped with an auxiliary heating belt for heat preservation, and the material of the auxiliary heat belt should be PE, EDPM, etc., with thickness of 20mm, to prevent the pipelines from freezing and thus cracking under low temperature. The power supply of the heating belt should be equipped with an independent fuse.
- n. When the ambient temperature is lower than 2°C, and the unit will be not used for a long time, water inside the unit should be drained. If the unit is not drained in winter, its power supply should not be cut off, and the fan coils in the water system must be provided with three-way valves, to ensure smooth circulation of the water system when the anti-freezing pump is started up in winter.
- o. The common outlet pipelines of combined units should be provided with mixing water temperature sensor.

Warning:

- For the water pipeline network including filters and heat exchangers, dreg or dirt may seriously damages the heat exchangers and water pipes.
- The installation persons or the users must ensure the quality of chilled water, and de-icing salt mixtures and air should be excluded from the water system, since they may oxidize and corrode steel parts inside the heat exchanger.

11.2.2 Water Quality

※Water quality control

When industrial water is used as chilled water, little furring may occur; however, well water or river water, used as chilled water, may cause much sediment, such as furring, sand, and so on. Therefore, well water or river water must be filtered and softened in softening water equipment before flowing into chilled water

system. If sand and clay settle in the evaporator, circulation of chilled water may be blocked, and thus leading to freezing accidents; if hardness of chilled water is too high, furring may occur easily, and the devices may be corroded. Therefore, the quality of chilled water should be analyzed before being used, such as PH value, conductivity, concentration of chloride ion, concentration of sulfide ion, and so on.

※ **Applicable standard of water quality for the unit**

PH value	Total hardness	Conductivity	Sulfide ion	Chloride ion	Ammonia ion	Sulfate ion	Silicon	Iron content	Sodium ion	Calcium ion
7~8.5	<50ppm	<20μV/cm(25°C)	No	<50ppm	No	<50ppm	<30ppm	<0.3ppm	No requirement	<50ppm

Performance adjustment factors

The antifreeze must be required according to anyone condition as following:

1. The outlet water temperature is below 5°C;
2. The ambient temperature is below 0 °C;
3. Don't start up the unit for a long time.
4. The power supply was cut off and needn't change the water in system.

Ethylene and Propylene Glycol Factors

A glycol solution is required when the unit with condition as mentioned. The use of glycol will reduce the performance of the unit depending on concentration.

Ethylene Glycol

Quality of glycol (%)	modification coefficient				Freezing point °C
	Cooling capacity modification	Power modification	Water resistance	Water flow modification	
0	1.000	1.000	1.000	1.000	0
10	0.984	0.998	1.118	1.019	-4.000
20	0.973	0.995	1.268	1.051	-9.000
30	0.965	0.992	1.482	1.092	-16.000
40	0.960	0.989	1.791	1.145	-23.000

Propylene Glycol

Quality of glycol (%)	Modification coefficient				Freezing point °C
	Cooling capacity modification	Power modification	Water resistance	Water flow modification	
0	1.000	1.000	1.000	1.000	0
10	0.976	0.996	1.071	1.000	-3.000
20	0.961	0.992	1.189	1.016	-7.000
30	0.948	0.988	1.380	1.034	-13.000
40	0.938	0.984	1.728	1.078	-22.000

Units operating with glycol solutions are not included in the ARI Certification Program.

Altitude correction factors

Performance tables are based at sea level. Elevations other than sea level affect the performance of the unit. The decreased air density will reduce condenser capacity and reduce the unit's performance. For performance at elevations other than sea level refer to Table 3. Maximum allowable altitude is 1800meters.

Evaporator temperature drop factors

Performance tables are based on a 5°C temperature drop through the evaporator. Adjustment factors for applications with temperature ranges from 3°C to 6°C in follow table. Temperature drops outside this range can affect the control system's capability to maintain acceptable control and are not recommended.

Fouling factor

Fouling refers to the accumulation of unwanted material on solid surfaces, most often in an aquatic environment. The fouling material can consist of either living organisms (biofouling) or a non-living substance (inorganic or organic). Fouling is usually distinguished from other surface-growth phenomena in that it occurs on a surface of a component, system or plant performing a defined and useful function, and that the fouling process impedes or interferes with this function.

Other terms used in the literature to describe fouling include: deposit formation, encrustation, crudding, deposition, scaling, scale formation, slagging, and sludge formation. The last six terms have a more narrow meaning than fouling within the scope of the fouling science and technology, and they also have meanings outside of this scope; therefore, they should be used with caution.

Fouling phenomena are common and diverse, ranging from fouling of ship hulls, natural surfaces in the marine environment (marine fouling), fouling of heat-transfer components through ingredients contained in the cooling water or gases, and even the development of plaque or calculus on teeth, or deposits on solar panels on Mars, among other examples.

Foreign matter in the chilled water system will adversely affect the heat transfer capability of the evaporator, and could increase the pressure drop and reduce the water flow. To provide optimum unit operation, proper water treatment must be maintained. Refer to the table as following.

Fouling Factor

ALTITUDE (m)	Difference of water inlet and outlet temp. (°C)	Fouling Factor							
		0.018°C /kW		0.044m ² °C /kW		0.086m ² °C/kW		0.172m ² °C/kW	
		C	P	C	P	C	P	C	P
Sea level	3	1.036	1.077	1.019	1.076	0.991	0.975	0.963	0.983
	4	1.039	1.101	1.022	1.080	0.994	0.996	0.971	0.984
	5	1.045	1.105	1.028	1.086	1.000	1.000	0.977	0.989
	6	1.051	1.109	1.034	1.093	1.006	1.004	0.983	0.994
600	3	1.024	1.087	1.008	1.064	0.980	0.984	0.951	0.991
	4	1.027	1.111	1.011	1.068	0.983	1.005	0.959	0.992
	5	1.034	1.115	1.017	1.074	0.989	1.009	0.965	0.997
	6	1.043	1.115	1.026	1.084	0.998	1.009	0.973	0.999
1200	3	1.013	1.117	0.996	1.052	0.969	1.011	0.942	1.002
	4	1.015	1.118	0.998	1.055	0.971	1.012	0.948	1.003
	5	1.023	1.122	1.006	1.063	0.979	1.015	0.955	1.005
	6	1.031	1.125	1.015	1.072	0.987	1.018	0.962	1.007
1800	3	1.002	1.128	0.986	1.042	0.959	1.021	0.935	1.007
	4	1.005	1.129	0.989	1.045	0.962	1.022	0.941	1.010
	5	1.012	1.132	0.995	1.051	0.968	1.024	0.945	1.012
	6	1.018	1.134	1.001	1.058	0.974	1.026	0.949	1.014

C--Cooling capacity

P--Power

11.2.3 Installation & regulation guide for target flow controller

- Please carefully check flow switches before conducting installation of the target flow controller. Packing should be in good condition, and the appearance should be free of damage and deformation. If any problem, please contact the manufacturer.

- Flow switches can be installed in the horizontal pipeline or the vertical pipeline with upward flowing direction but cannot be mounted in the pipeline with downward flowing direction. The inlet water of gravity should be taken into account when flow switches are installed in the pipeline with upward flowing direction.

- Target flow controller must be installed on a section of straight-line pipeline, and its both ends must be supplied with straight-line pipes whose length is at least 5 times diameter of the pipe. In the meanwhile, the fluid flowing direction in the pipeline must be consistent with the direction of arrow on the controller. The connection terminal should be located where wiring connection can be easily done.

- Pay attention to the following items when conducting installation and wire connection:

- a. Collision of the wrench with the soleplate of the flow switch is prohibited, since such collision may cause deformation and failure of the flow switch.

- b. To avoid electric shock and damages to the devices, the power supply should be cut off, when wires are connected or adjustment is done.

- c. When wiring connection is conducted, adjustment of other screws except connection terminals of micro switches and ground screws is prohibited. In the meanwhile, over great force should not applied when wires of micro switches are connected, otherwise micro switches may suffer displacement, thus leading to failure of flow switches.

d. Special grounding screws should be used for earth connection. Bolts should not be installed or removed at will; otherwise flow switches may suffer deformation and failure.

e. Flow switches have been set at minimal flow value before leaving the factory. They should not be adjusted below the setting value at the factory, or they may suffer failure. After installing flow switches, please press the flow switch lever several times to check them. When the lever is found not to respond with “clatter”, rotate the screw in a clockwise direction, until “clatter” occurs.

f. Be sure to determine the model of target slice according to the rated flow of the unit, the diameter of the outlet pipe and the adjustment range of the target slice of the flow switch. Besides, the target slice should not contact with other restrictors in the pipeline or on the inner wall of the pipeline, or the flow switch cannot be reset normally.

- Determine whether the flow switch and the system connected with it are in good operation according to the measured value by flow meter, namely, when the measured value on flow meter is less than 60% of rated water flow of the unit, the target flow controller should be cut off and observed for 3 working periods, and it should be covered with flow switch shell timely.

Schematic diagram of water flow switch

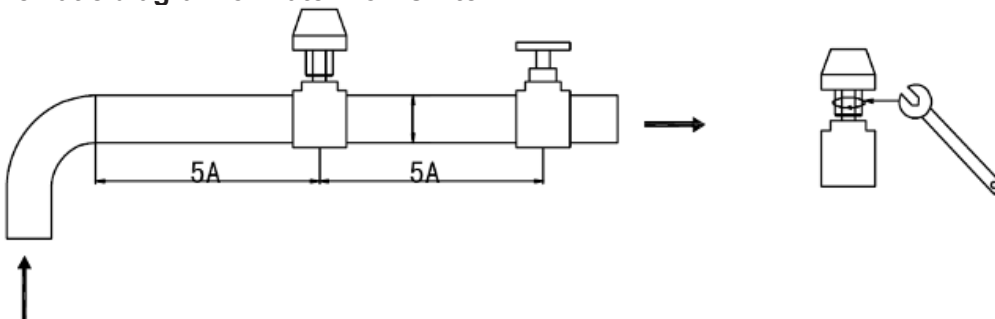

11.2.4 Installation of water system pipeline for 30kW module Installation of single-module water system pipeline

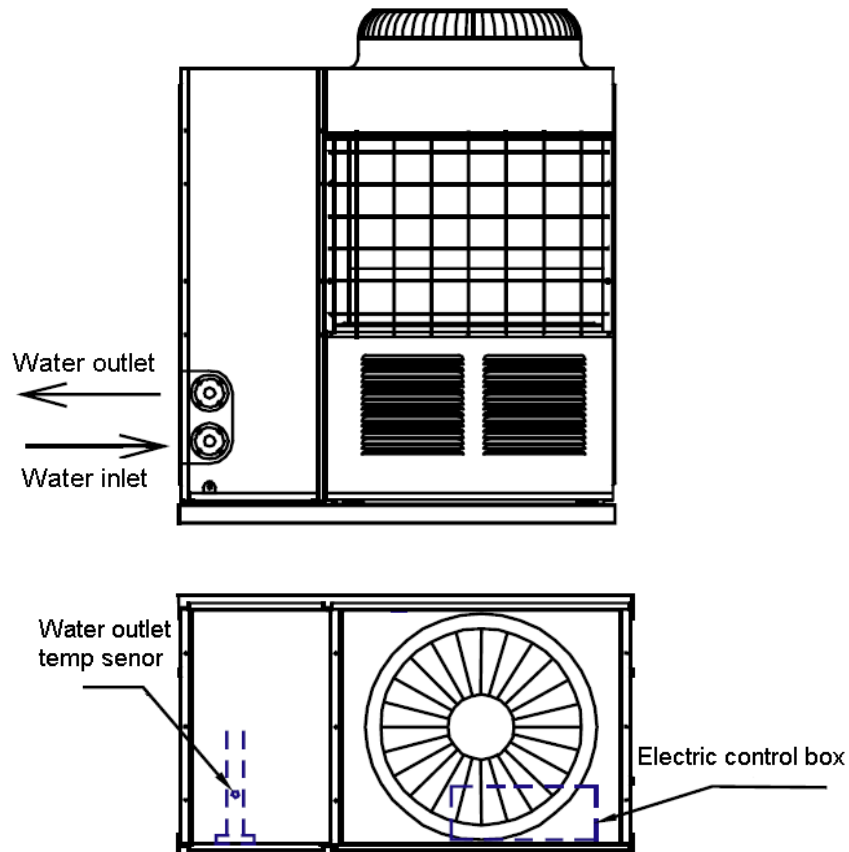

Installation of multi-module water system pipeline

1) Installation mode I (recommended installation mode)

n :the module quantity, max 16

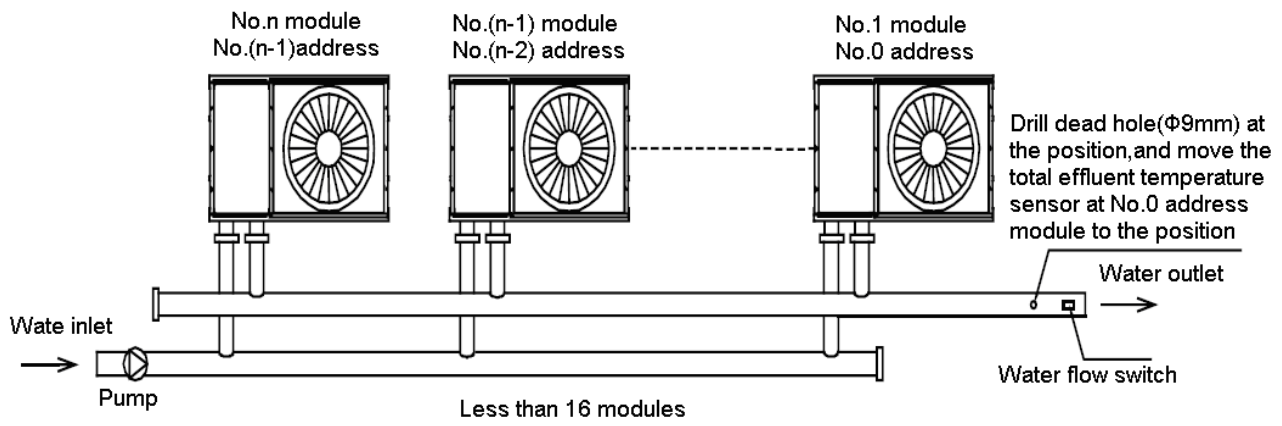

2) Installation mode II
n :the module quantity, max 16

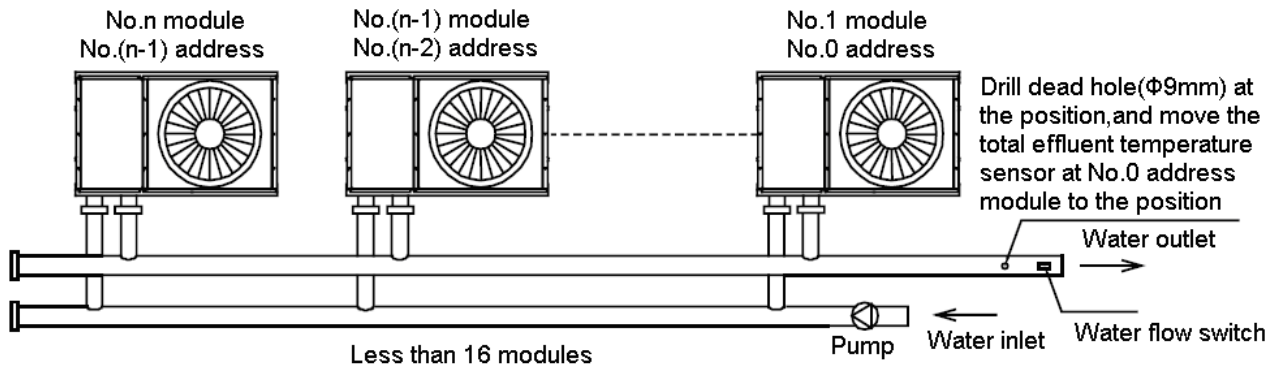

11.2.5 Installation of water system pipeline for 65kW module
Installation of single-module water system pipeline

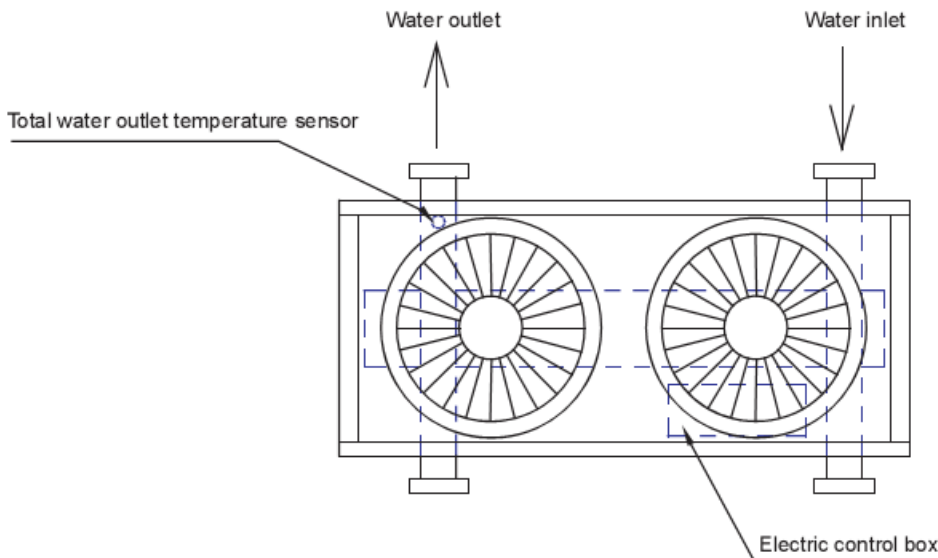

Installation of multi-module water system pipeline
1) Installation mode I (recommended installation mode)
n :the module quantity, max 6

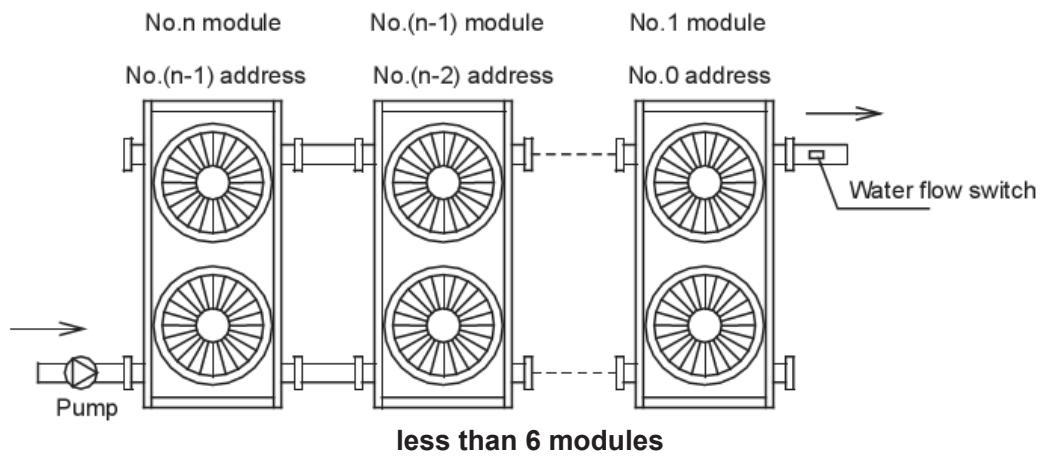

2) Installation mode III (recommended installation mode)

n : the module quantity, max 16

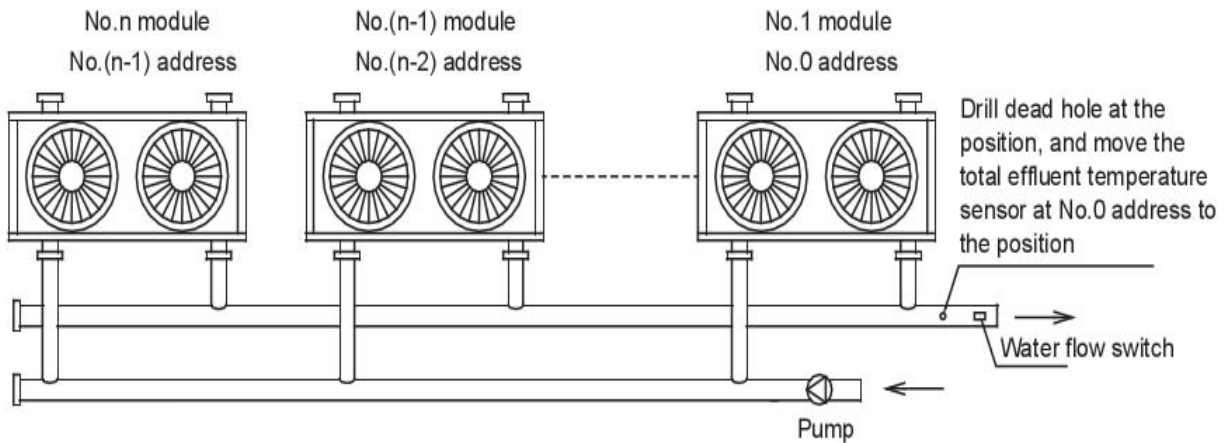
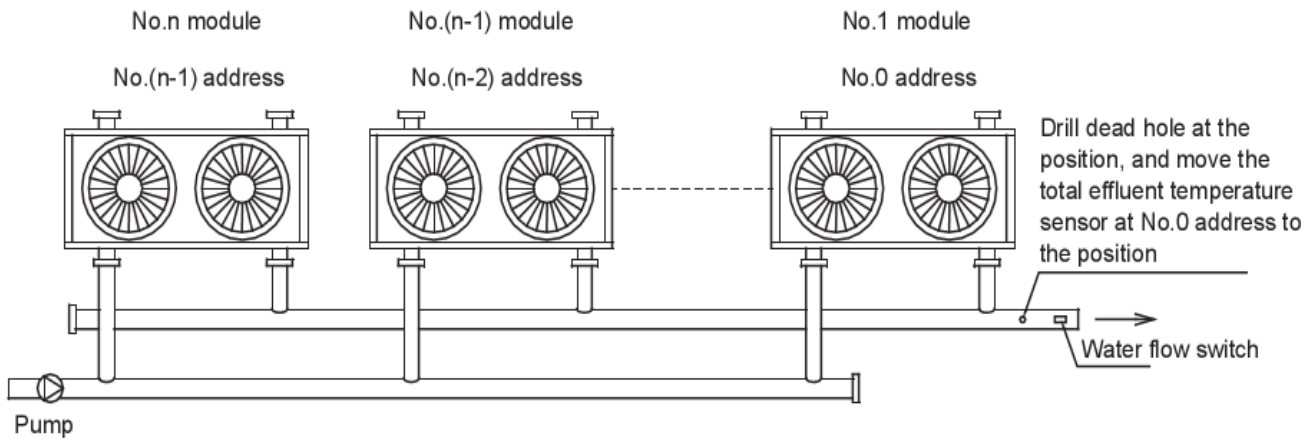

3) Installation mode IV

n : the module quantity, max16

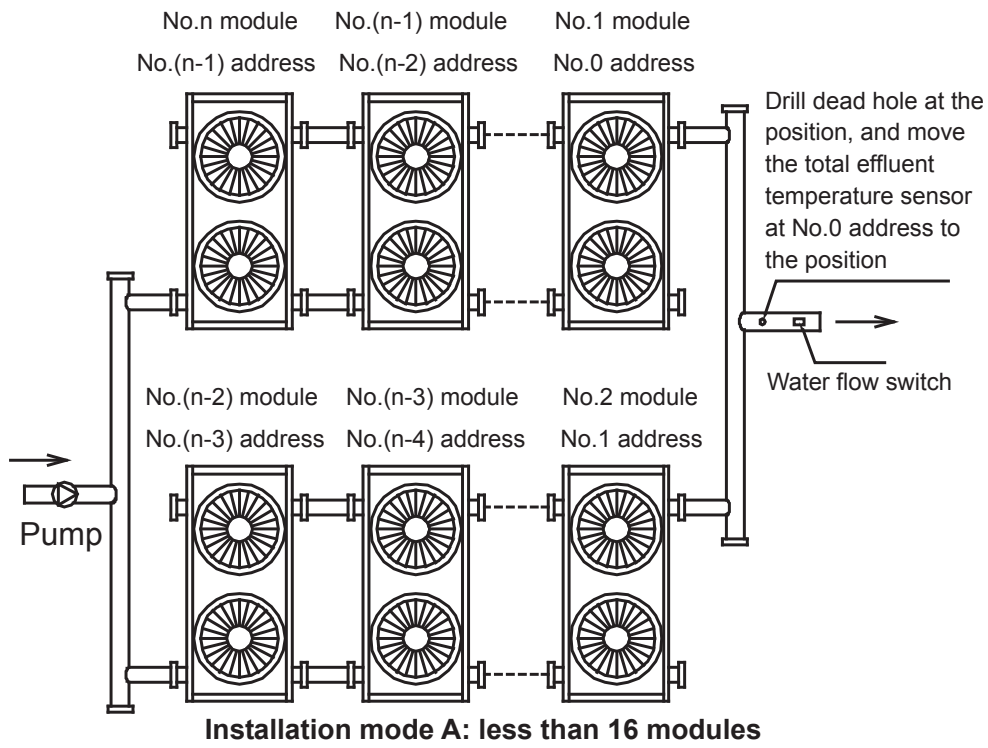

4) Installation mode V

n : the module quantity, max8

m : the module quantity, max8

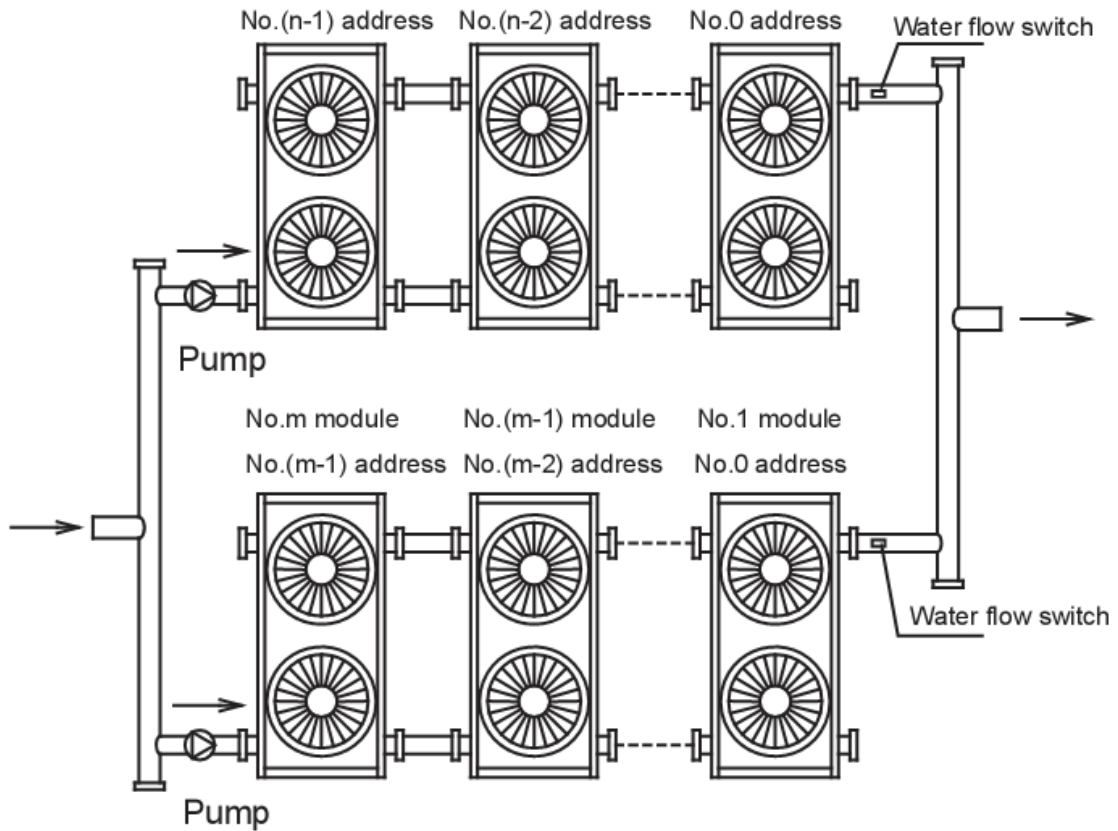

11.2.6 Installation of water system pipeline for 130kW module

Installation of single-module water system pipeline

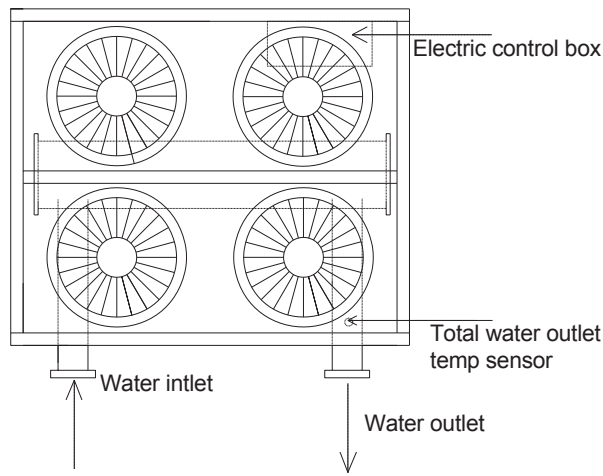

Installation of multi-module water system pipeline

1) Installation mode I (recommended installation mode)

n : the module quantity, max8

No.1 unit
No.0 address(main unit)
No.1 address

No.(n-1) unit
No.(2n-3) address
No.(2n-4) address

No.n unit (n≤8)
No.(2n-1) address
No.(2n-2) address

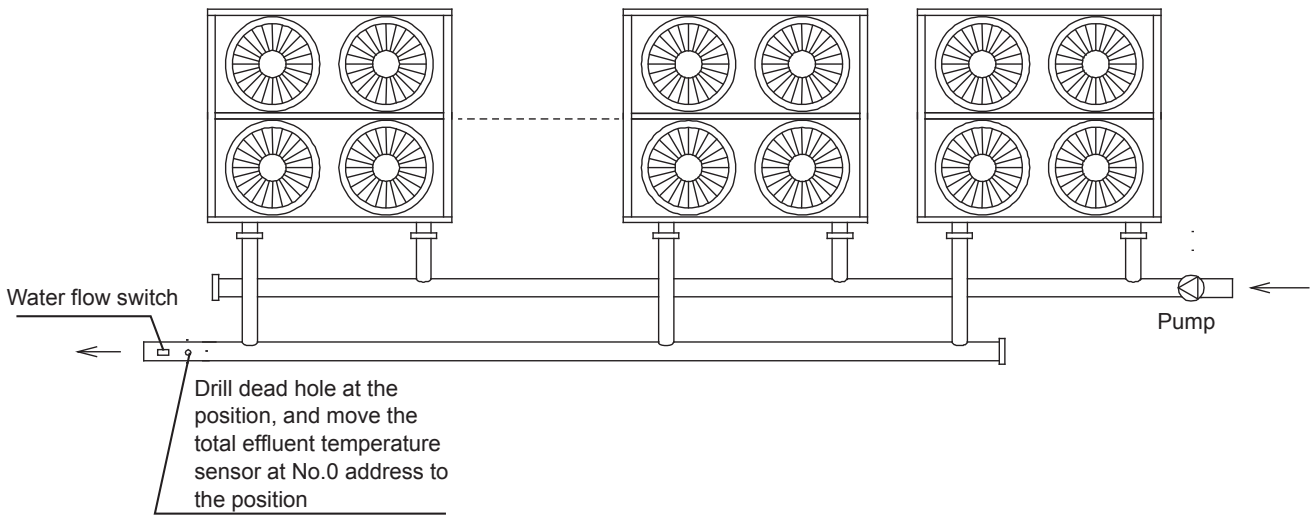

Installation mode B: less than 8 modules

2) Installation mode II

n : the module quantity, max8

No.n unit (n≤8)
No.(2n-1) address
No.(2n-2) address

No.(n-1) unit
No.(2n-3) address
No.(2n-4) address

No.1 unit
No.0 address(main unit)
No.1 address

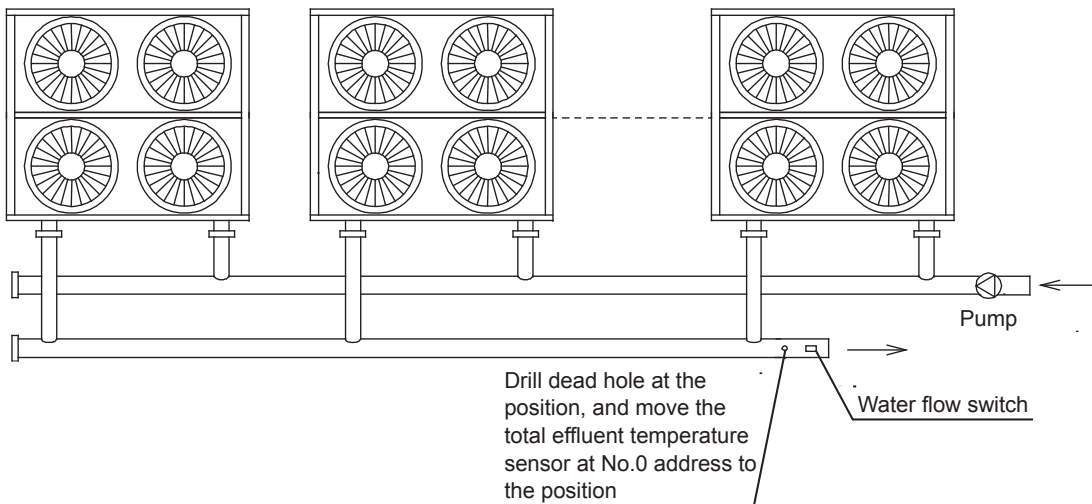

Installation mode B: less than 8 modules

11.2.7 Installation of water system pipeline for 200kW module

Multi-module combination installation involves special design of the unit, so relevant explanation is given as follows. Installation mode of multi-module combination water system pipeline

n : the module quantity, max5

a. Installation mode I (recommended installation mode)

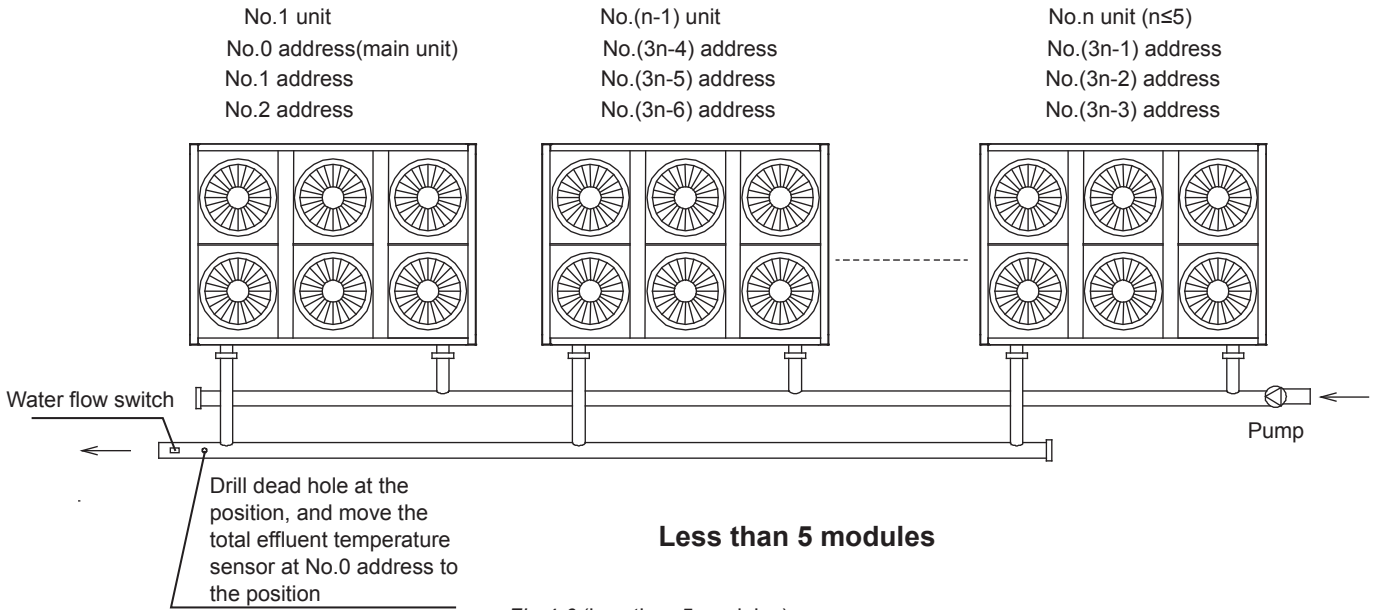

b. Installation mode II

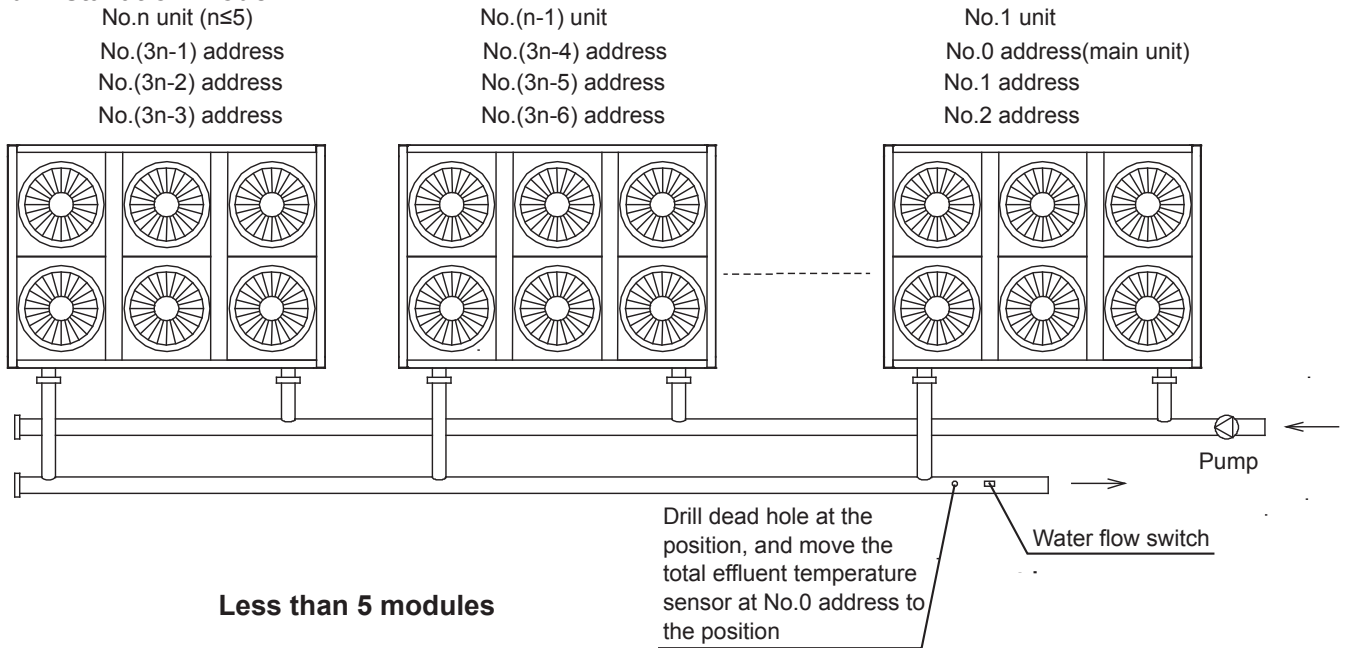

11.2.8 Installation of water system pipeline for 250kW module

Multi-module combination installation involves special design of the unit, so relevant explanation is given as follows. Installation mode of multi-module combination water system pipeline.

n : the module quantity, max8

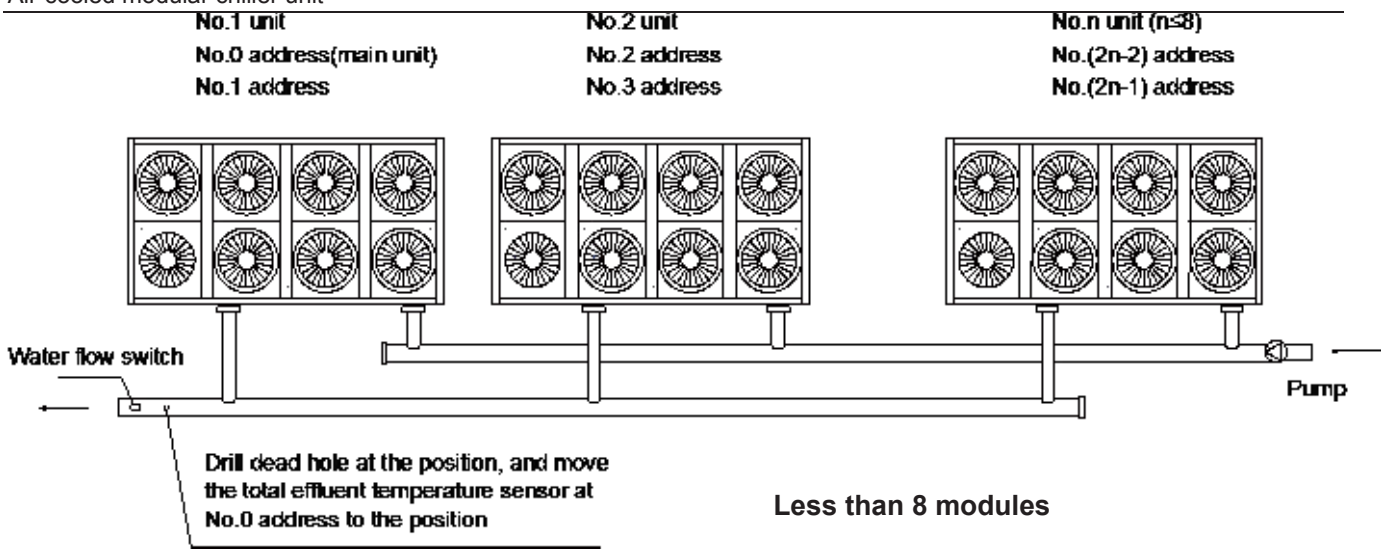

Notice:

- 1) For installation of multi-module, the most modules should be not more than 8 modular units.
- 2) For installation of multi-module, please drill a dead hole(Φ9mm) at the total water outlet pipeline, and move the total water effluent temperature sensor at No.0 address to the hole.

Table of diameter parameters of main inlet and outlet pipes for 30kW module

Unit model x quantity	Total inlet and outlet water pipe diameter	Unit model x quantity	Total inlet and outlet water pipe diameter
30×1	DN40	30×9	DN100
30×2		30×10	
30×3		30×11	
30×4	DN65	30×12	DN125
30×5		30×13	
30×6		30×14	
30×7	DN80	30×15	
30×8		30×16	

Table of diameter parameters of main inlet and outlet pipes for 65kW module

Unit model x quantity	Total inlet and outlet water pipe diameter	Unit model x quantity	Total inlet and outlet water pipe diameter
65×1	DN65	65×9	DN125
65×2		65×10	
65×3	DN80	65×11	
65×4	DN100	65×12	DN150
65×5		65×13	
65×6		65×14	
65×7	DN125	65×15	DN200
65×8		65×16	

Table of diameter parameters of main inlet and outlet pipes for 130kW module

Unit model x quantity	Total inlet and outlet water pipe diameter	Unit model x quantity	Total inlet and outlet water pipe diameter
130×1	DN65	130×5	DN125
130×2	DN100	130×6	DN150
130×3	DN100	130×7	DN150
130×4	DN125	130×8	DN200

Table of diameter parameters of main inlet and outlet pipes for 185kW module

Unit model x quantity	Total inlet and outlet water pipe diameter	Unit model x quantity	Total inlet and outlet water pipe diameter
200×1	DN80	200×4	DN150
200×2	DN100	200×5	DN200
200×3	DN125		

Table of diameter parameters of main inlet and outlet pipes for 250kW module

Unit model x quantity	Total inlet and outlet water pipe diameter	Unit model x quantity	Total inlet and outlet water pipe diameter
250×1	DN100	250×5	DN150
250×2	DN100	250×6	DN200
250×3	DN125	250×7	DN250
250×4	DN150	250×8	DN250

Please pay attention to the following items when installing multiple modules:

- Each module corresponds to an address code which cannot be repeated.
- Main water outlet temperature sensing bulb, target flow controller and auxiliary electric heater are under control of the main module.
- One wired controller and one target flow controller are required and connected on the main module.
- The unit can be started up through the wired controller only after all addresses are set and the aforementioned items are determined. The wired controller is ≤50m away from the outdoor unit.

11.2.9 Chilled water flow**Minimum chilled water flow**

The minimum chilled water flow is shown in the below table.

If the system flow is less than the minimum unit flow rate, the evaporator flow can be recalculated, as shown in the diagram.

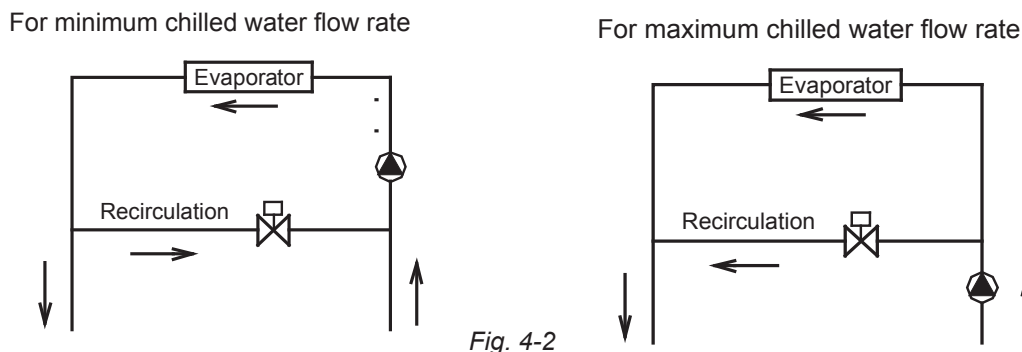
**Maximum chilled water flow**

The maximum chilled water flow is limited by the permitted pressure drop in the evaporator. It is provided in the below table.

If the system flow is more than the maximum unit flow rate, bypass the evaporator as shown in the diagram to obtain a lower evaporator flow rate.

Minimum and Maximum water flow rates

Model \ Item	Water flow rate(m ³ /h)	
	Minimum	Maximum
MCCH30A-TA3SL	4.68	5.72
MCDH30A-TA3SL	4.68	5.72
MCCH65A-SA3L	10.08	12.32
MCCD65A-SA3L	10.08	12.32
MCCH130A-SA3L	18.54	22.66
MCCH185A-SA3	27.9	34.1
MCCH250A-SA3T	38.7	47.3

11.2.10 Design of the store tank in the system

a. kW is the unit for cooling capacity, L is the unit for (G) minimum water flow volume in the formula.

Comfortable type air conditioner

$G = \text{cooling capacity} \times 2.6L$

Process type cooling

$G = \text{cooling capacity} \times 7.4L$

b. In certain occasion (especially in manufacture cooling process), for conforming the system water content requirement, it's necessary to mount a tank equipping with a cut-off baffle at the system to avoid water short-circuit, Please see the following schemes:

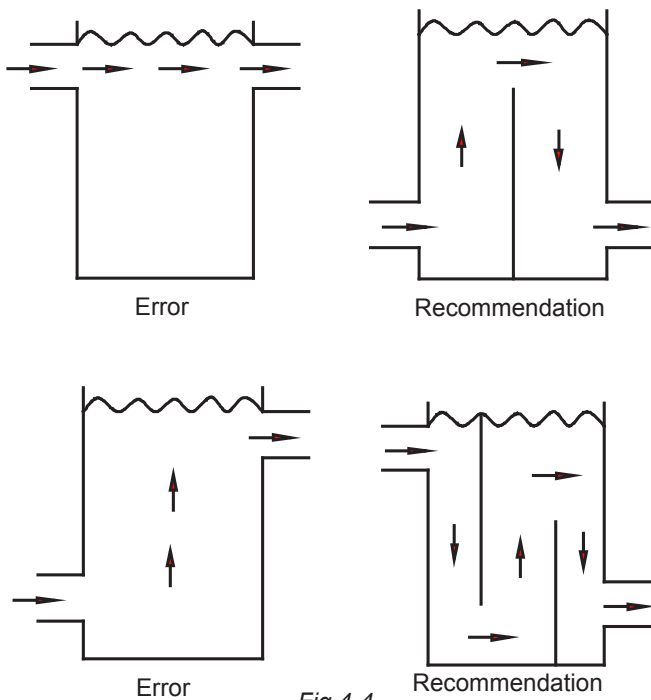

Fig.4-4

11.2.11 Design of expansion tank

If a closed expansion tank with its filled volume of air is too small, the system pressure will easily exceed the

maximum allowable pressure and cause water to discharge from the pressure relief valve, thus wasting water. If the closed tank is too large, when the water temperature drops, the system pressure may decrease to a level below the minimum allowable value and cause trouble in the air vent. Therefore, accurate sizing of a closed expansion tank is essential.

For diaphragm expansion tanks, the minimum volume of the water tank, V_t , gal(m^3), can be calculated by the following formula, recommended by ASHRAE Handbook 1996, HVAC Systems and Equipment:

$$V_t = V_s \left\{ \frac{v_2/v_1 - 1 - 3\alpha(T_2 - T_1)}{1 - p_1/p_2} \right\}$$

T_1 = lower temperature, °F (°C)

T_2 = higher temperature, °F (°C)

V_s = volume of water in system, gal(m^3)

p_1 = absolute pressure at lower temperature, psia (kPa abs.)

p_2 = absolute pressure at higher temperature, psia (kPa abs.)

v_1, v_2 = specific volume of water at lower and higher temperature, respectively, ft³/lb (m^3 /kg)

α = linear coefficient of thermal expansion; for steel, $\alpha = 6.5 \times 10^{-6}$ in./in. • °F (1.2×10^{-5} per °C); for copper,

$\alpha = 9.5 \times 10^{-6}$ in./in. • °F (1.7×10^{-5} per °C)

In a chilled water system, the higher temperature T_2 is the highest anticipated ambient temperature when the chilled water system shuts down during summer. The lower temperature in a heating system is often the ambient temperature at fill conditions (for example, 50 °F or 10 °C).

11.2.12 Selection and installation of the pump

(1) Select the pump

a. Select the water-flow of the pump

The rated water-flow must no less than the unit rated water-flow; in terms of multi-connect the units, that water-flow must no less than total units' rated water-flow.

b. Select the lift of the pump.

$$H = h_1 + h_2 + h_3 + h_4$$

H: The lift of the pump.

h_1 : Main unit water resistance.

h_2 : Pump water resistance.

h_3 : Water resistance of the longest water-loop distance, includes: pipe resistance, different valve's resistance, flexible pipe resistance, pipe elbow and three-way resistance, two-way resistance or three-way resistance, as well as filter resistance.

h_4 : the longest terminal resistance.

(2) Installation the pump

a. The pump should be installed at the water inlet pipe, both of which sides must mount the soft connectors for vibration-proof.

b. The backup pump for the system (recommended).

c. Units must with a main unit controls (Please see "4.5 fielding wiring" for the controls diagram).

11.3 Wiring Installation

All wiring installation should be done by qualified person.

11.3.1 Precautions:

1. The air-conditioner should apply special power supply, whose voltage should conform to rated voltage.
2. Wiring construction must be conducted by the professional technicians according to the labeling on the circuit diagram.
3. Only use the electric components specified by our company, and require installation and technical services from the manufacturer or authorized dealer. If wiring connection fails to conform to electric installation norm, failure of the controller, electronic shock, and so on may be caused.
4. The connected fixed wires must be equipped with full switching-off devices with at least 3mm contact separation.
5. Set leakage protective devices according to the requirements of national technical standard about electric equipment.
6. After completing all wiring construction, conduct careful check before connecting the power supply.
7. Please carefully read the labels on the electric cabinet.
8. The user's attempt to repair the controller is prohibited, since improper repair may cause electric shock, damages to the controller, and so on. If the user has any requirement of repair, please contact the maintenance center.

11.3.2 Power supply specification

Model	Items	Outdoor power supply			Wiring
		Power supply	Manual switch	Fuse	
MCCH30A-TA3SL MCDH30A-TA3SL		380~415V 3Ph~50Hz	50A	36A	10mm ² (<30m)
MCCH65A-SA3L		380~400V 3Ph~50Hz	150A	100A	16mm ² (<20m)
MCCD65A-SA3L		380~415V 3Ph~50Hz	150A	100A	16mm ² (<20m)
MCCH130A-SA3L		380~400V 3Ph~50Hz	250A	200A	Base on the actual distance of the wire, more than 35 mm ² for each module
MCCH185A-SA3		380~400V 3Ph~50Hz	400A	300A	According to the actual distance of wiring, 70mm ² or larger for each unit.
MCCH250A-SA3T		380~400V 3Ph~50Hz	450A	350A	According to the actual distance of wiring, 185mm ² or larger for each unit.

11.3.3 Requirements of wiring connection

- No additional control components are required in the electric cabinet (such as relay, and so on), and the power supply and control wires not connected with the electric cabinet are not allowed to go through the electric box. Otherwise, electromagnetic interference may cause failure of the unit and control components and even damages to them, which thus lead to protective failure.
- All cables led to the electrical box should be supported independently but by the electric box.
- The strong current wires generally pass the electrical box, and 220V alternating current may also pass the control board, so wiring connection should conform to the principle of separation of strong current and weak current, and the wires of power supply should be kept more than 100 mm away from the control wires.

- Only use 380-415V 3Ph 50Hz rated power supply for the unit, and the maximum allowable range of voltage is 342V-418V.
- All electric wires must conform to local wiring connection norm. The suitable cables should be connected to power supply terminal through wiring connection holes at the bottom of the electric cabinet. According to Chinese standard, the user is responsible for providing voltage and current protection for the input power supply of the unit.
- All power supplies connected to the unit must pass one manual switch, to ensure that the voltages on all nodes of electric circuit of the unit are released when the switch is cut off.
- The cables of correct specification must be used to supply power for the unit. The unit should use independent power supply, and the unit is not allowed to use the same power supply together with other electric devices, to avoid over-load danger. The fuse or manual switch of the power supply should be compatible with working voltage and current of the unit. In case of parallel connection of multiple modules, the requirements of wiring connection mode and configuration parameters for the unit are shown in the following figure.
- Some connection ports in the electric box are switch signals, for which the user needs to provide power, and the rate voltage of the power should be 220-230V AC. The user must be aware that all power supplies they provided should be obtained through power circuit breakers (provided by the user), to ensure that all voltages on the nodes of the provided power supply circuit are released when the circuit breakers are cut off.
- All inductive components provided by the user (such as coils of contactor, relay, and so on) must be suppressed with standard resistance-capacitance suppressors, to avoid electromagnetic interference, thus leading to failure of the unit and its controller and even damages to them.
- All weak current wires led to the electric box must apply shielded wires, which must be provided with grounding wires. The shield wires and power supply wires should be laid separately, to avoid electromagnetic interference.
- The unit must be provided with grounding wires, which are not allowed to be connected with the grounding wires of gas fuel pipelines, water pipelines, lightning conductors or telephones. Improper earth connection may cause electric shock, so please check whether earth connection of the unit is firm or not frequently.

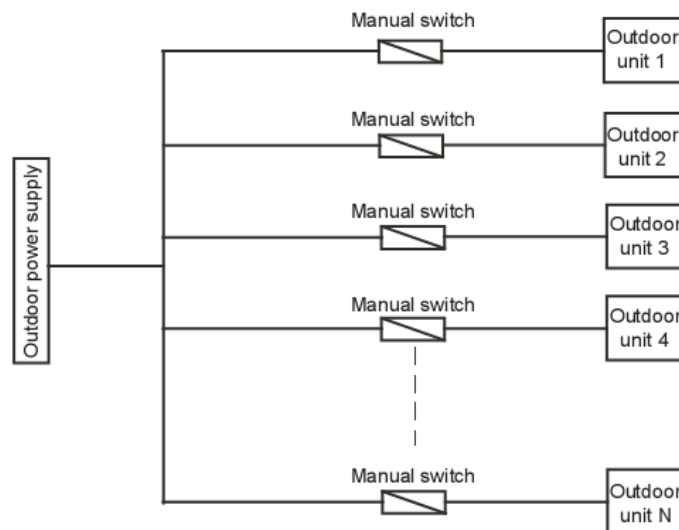

Notice:

- 1) 30kW module only 16 modular units can be combined at most.
- 2) 65kW module only 16 modular units can be combined at most.
- 3) 130kW module only 8 modular units can be combined at most.
- 4) 185kW module only 5 modular units can be combined at most.
- 5) 250kW module only 8 modular units can be combined at most.

11.3.4 Wiring steps

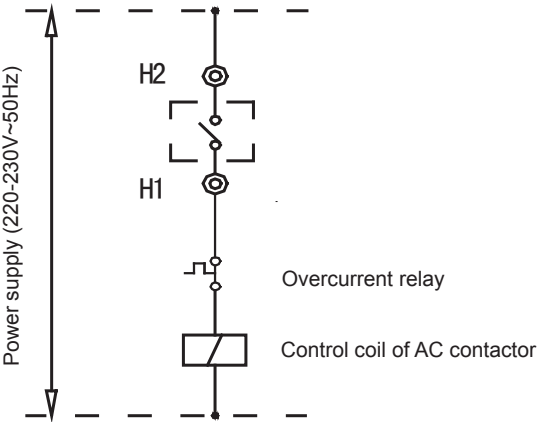
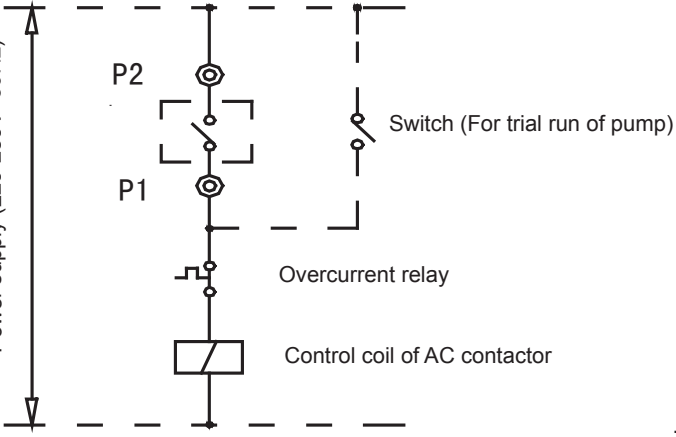
Step	Content
1	Check the unit and ensure that it is connected with grounding wires correctly, to avoid leakage, and the grounding devices should be mounted in strict accordance with the requirements of electrical engineering rules. The grounding wires can prevent electric shock.
2	The control box of the main power switch must be mounted in a proper position.
3	Wiring connection holes of the main power should be provided with glue cushion.
4	The main power and neutral wires and grounding wires of power supply are led into the electric box of the unit.
5	The wires of the main power must pass the bonding clamp.
6	Wires should be connected firmly to the connection terminals L1, L2, L3, N and PE.
7	Phase sequences must be consistent when the wires of the main power.
8	The main power should be located out of easy reach of non-professional maintenance personnel, to avoid mal-operation and improve safety.
9	Connection of control wires of water flow switches: the wire leads (prepared by the user) of water flow switches are connected to the connection terminals W1 and W2 of the main unit.
10	Connection of control wires of auxiliary electric heaters: the control wires of AC contactor of the auxiliary electric heater must pass the connection terminals H1 and H2 of the main unit, as shown.
10	 <p>The diagram shows a power supply (220-230V~50Hz) connected to terminals H2 and H1. The circuit includes an overcurrent relay and the control coil of an AC contactor.</p>
11	<p>Connection of control wires of pump: the control wires of AC contactor of the pump must pass the connection terminals P1 and P2 of the main unit, as shown</p>  <p>The diagram shows a power supply (220-230V~50Hz) connected to terminals P2 and P1. The circuit includes a switch (For trial run of pump), an overcurrent relay, and the control coil of an AC contactor.</p>
12	The connection way of the wired controller connects with every signal wires from package units: signal wires P, Q, E are connected in the same way of main wires connection method and accordingly connect to the terminals P, Q, E in the wired controller.

Note: (For the module with KJR-120A/MBE)

①. Wiring of “ON/OFF” weak electric port

Corresponding parallel connect the “ON/OFF” port of the main unit’s electric control box, then, connect the “ON/OFF” signal (provide by user) to the “ON/OFF” port of main unit as follows.

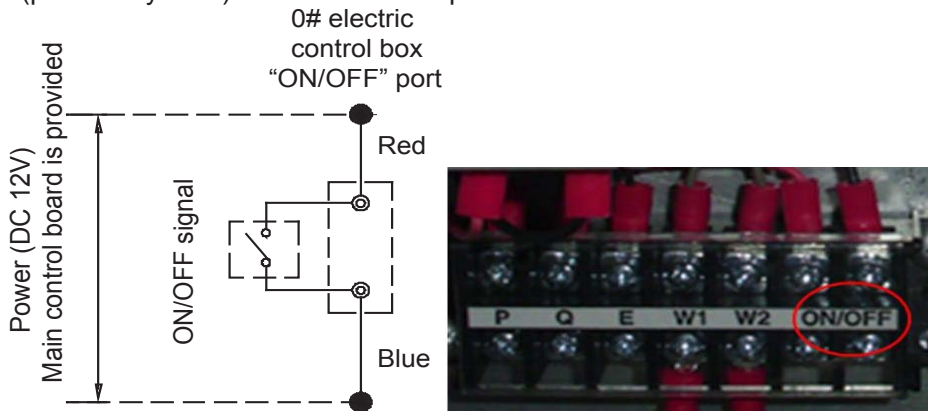

②. Remote mode selection: Wiring of “HEAT/COOL” weak electric port

Corresponding parallel connect the “HEAT/COOL” port of the main unit’s electric control box, then, connect the “ON/OFF” signal (provide by user) to the “HEAT/COOL” port of main unit as follows.

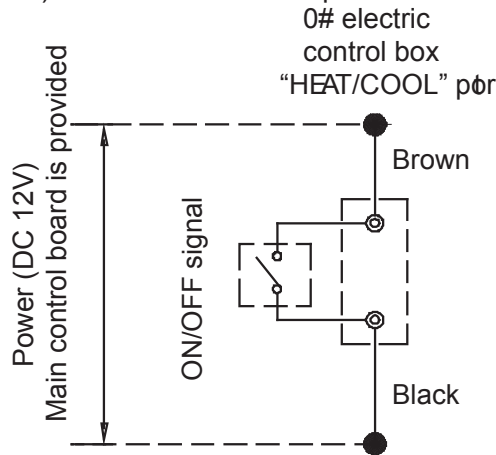

③. Wiring of “ALARM” port

Connect the device provided by user to the “ALARM” ports of the module units as follows.

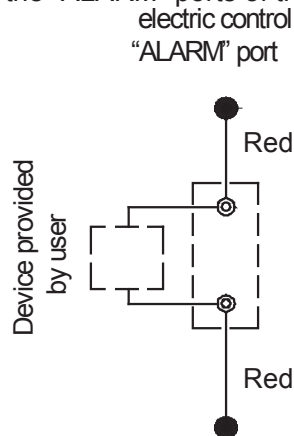

If the unit is operating normally, the ALARM port is closed, otherwise, the ALARM port is not closed.

12 Commissioning

1. Preparation

- After the water system pipeline is flushed several times, please make sure that the purity of water meets the requirements; the system is re-filled with water and drained, and the pump is started up, then make sure that water flow and the pressure at the outlet meet the requirements.
- The unit is connected to the main power 12 hours before being started up, to supply power to the heating belt and pre-heat the compressor. Inadequate pre-heating may cause damages to the compressor.
- Setting of the wired controller. See details of the manual concerning setting contents of the controller, including such basic settings as refrigerating and heating mode, manual adjustment and automatic adjustment mode and pump mode. Under normal circumstances, the parameters are set around standard operating conditions for trial run, and extreme working conditions should be prevented as much as possible.
- Carefully adjust the target flow controller on the water system or the inlet stop valve of the unit, to make the water flow of the system accord with the water flow in specification table.

2. Test run

1 Start up the controller and check whether the unit displays a fault code. If a fault occurs, remove the fault first, and start the unit according to the operating method in the “unit control instruction”, after determining that there is no fault existing in the unit.

2 Conduct trial run for 30 min. When the influent and effluent temperature becomes stabilized, adjust the water flow to nominal value, to ensure normal operation of the unit.

3 After the unit is shut down, it should be put into operation 10 min later, to avoid frequent start-up of the unit. In the end, check whether the unit meets the requirements in specification table.



Notice:

- The unit can control start-up and shut-down of the unit, so when the water system is flushed, the operation of the pump should not be controlled by the unit.
- Do not start up the unit before draining the water system completely.
- The water flow switch must be installed correctly. The wires of the water flow switch must be connected according to electric control schematic diagram, or the faults caused by water breaking while the unit is in operation should be the user's responsibility.
- Do not re-start the unit within 10 min after the unit is shut down during trial run.
- When the unit is used frequently, do not cut off the power supply after the unit is shut down; otherwise the compressor cannot be heated, thus leading to its damages.
- If the unit is not in service for a long time, and the power supply needs to be cut off, the unit should be connected to the power supply 12 hours prior to re-starting of the unit, to pre-heat the compressor.

13 Maintenance

Maintenance for main components:

- Close attention should be paid to the discharge and suction pressure during the running process. Find out reasons and eliminate the failure if abnormality is found.
- Control and protect the equipment. See to it that no random adjustment be made on the set points on site.
- Regularly check whether the electric connection is loose, and whether there is bad contact at the contact point caused by oxidation and debris etc., and take timely measures if necessary. Frequently check the work voltage, current and phase balance.
- Check the reliability of the electric elements in time. Ineffective and unreliable elements should be replaced in time.

Removing scale

After long-time operation, calcium oxide or other minerals will be settled in the heat transfer surface of the water-side heat exchanger. These substances will affect the heat transfer performance when there is too much scale in the heat transfer surface and sequentially cause that electricity consumption increases and the discharge pressure is too high (or suction pressure too low). Organic acids such as formic acid, citric acid and acetic acid may be used to clean the scale. But in no way should cleaning agent containing chlorine acid or fluoride should be used as the water-side heat exchange is made from stainless steel and is easy to be eroded to cause refrigerant leakage. Pay attention to the following aspects during the cleaning and scale-removing process:

- Water-side heat exchanger should be done by professionals.
- Clean the pipe and heat exchanger with clean water after cleaning agent is used. Conduct water treatment to prevent water system from being eroded or re-absorption of scale.
- In case of using cleaning agent, adjust the density of the agent, cleaning time and temperature according to the scale settlement condition.
- After pickling is completed, neutralization treatment needs to be done on the waste liquid. Contact relevant company for treating the treated waste liquid.
- Protection equipment (such as goggles, gloves, mask and shoes) must be used during the cleaning process to avoid breathing in or contacting the agent as the cleaning agent and neutralization agent is corrosive to eyes, skins and nasal mucosa.

Winter shutdown

For shutdown in winter, the surface of the unit outside and inside should be cleaned and dried. Cover the unit to prevent dust. Open discharge water valve to discharge the stored water in the clean water system to prevent freezing accident (it is preferable to inject antifreeze in the pipe).

Replacing parts

Parts to be replaced should be the ones provided by our company. Never replace any part with different part.

First startup after shutdown

The following preparations should be made for re-startup of unit after long-time shutdown:

- 1) Thoroughly check and clean the unit.
- 2) Clean water pipe system.
- 3) Check pump, control valve and other equipment of water pipe system.
- 4) Fix connections of all wires.
- 5) It is a must to electrify the machine before startup.

Refrigeration system

Determine whether refrigerant is needed by checking the value of suction and discharge pressure and check whether there is a leakage. Air tight test must be made if there is a leakage or parts of refrigerating system is to be replaced. Take different measures in the following two different conditions from refrigerant injection.

- 1) Total leakage of refrigerant. In case of such situation, leakage detection must be made on the pressurized nitrogen used for the system. If repair welding is needed, welding cannot be made until all the gas in the

system is discharged. Before injecting refrigerant, the whole refrigeration system must be completely dry and of vacuum pumping.

- Connect vacuum pumping pipe at the fluoride nozzle at low-pressure side.
- Remove air from the system pipe with vacuum pump. The vacuum pumping lasts for above 3 hours. Confirm that the indication pressure in dial gauge is within the specified scope.

When the degree of vacuum is reached, inject refrigerant into the refrigeration system with refrigerant bottle. Appropriate amount of refrigerant for injection has been indicated on the nameplate and the table of main technical parameters. Refrigerant must be injected from the low pressure side of system.

- The injection amount of refrigerant will be affected by the ambient temperature. If the required amount has not been reached but no more injection can be done, make the chilled water circulate and start up the unit for injection. Make the low pressure switch temporarily short circuit if necessary.

2) Refrigerant supplement. Connect refrigerant injection bottle on the fluoride nozzle at low-pressure side and connect pressure gauge at low pressure side.

- Make chilled water circulate and start up unit, and make the low pressure control switch short circuit if necessary.
- Slowly inject refrigerant into the system and check suction and discharge pressure.

Disassembling compressor

Follow the following procedures if compressor needs to be disassembled:

- 1) Cut off the power supply of unit.
- 2) Remove power source connection wire of compressor.
- 3) Remove suction and discharge pipes of compressor.
- 4) Remove fastening screw of compressor.
- 5) Move the compressor.

Auxiliary electric heater

When the ambient temperature is lower than 2 °C, the heating efficiency decreases with the decline of the outdoor temperature. In order to make the air-cooled heat pump stably run in a relatively cold region and supplement some heat lost due to de-frosting. When the lowest ambient temperature in the user's region in winter is within 0 C~10 C, the user may consider to use auxiliary electric heater. Please refer to relevant professionals for the power of auxiliary electric heater.

System anti-freezing

In case of freezing at the water-side heat exchanger interval channel, severe damage may be caused, i.e. heat exchange may be broken and appears leakage. This damage of frost crack is not within the warranty scope, so attention must be paid to anti-freezing.

- 1) If the unit that is shut down for standby is placed in an environment where the outdoor temperature is lower than 0 C, the water in the water system should be drained.
- 2) Water pipe may be frozen when the chilled water target flow controller and anti-freezing temperature sensor become ineffective at running, therefore, the target flow controller must be connected in accordance with the connection diagram.
- 3) Frost crack may happen to water-side heat exchanger at maintenance when refrigerant is injected to the unit or is discharged for repair. Pipe freezing is likely to happen any time when the pressure of refrigerant is below 0.4Mpa. Therefore, the water in the heat exchanger must be kept flowing or be thoroughly discharged.

Regularly preventive maintenance plan

Maintenance Items		Frequency	Qualify Standards (Settlement)	Note	
General	Noise	Anytime	Judge whether there is abnormal sound by hearing;	Watch from one meter away from the center of the unit;	
	Vibration	Anytime	Watch whether the swings of distribution pipes and components are too large		
	Voltage	Anytime	Rating voltage is within $\pm 10\%$		
Appearance	Clean	Anytime	Keep it clean anytime		
	Calm	Anytime	Lock each snail		
	Insulation material flakes	Anytime	Stick it		
	Water leak	Once/ Month	Check whether the exhaust water pipe blocks		
Compressor	Noise	Anytime	Whether there is abnormal sound when starts up, runs or stops		
	Insulation resistance	Once/ Year	Above $5M\Omega$ is required when testing with DV500V high resistance meter		
	Hock proof rubber gets old	Once/ Year	Flexible when pressed with hands is qualified		
	Medium check	Once/3000 hours	Pay attention to the noise libation and oil level		
	Medium check	Once/6000 hours	Confirm the action of safety device and protection device		
Fin-coil heat exchanger	Fan	Anytime	Normal wind amount, high pressure when refrigerating and low pressure when heating within the normal range		
	Clean frequency	Once/Month	Normal wind amount, high pressure when refrigerating and low pressure when heating within the normal range		
Shell land tube heat exchanger	Water flow of the user side	Anytime	Within $\pm 5\%$ of the standard		
	Temperature	Anytime	Within the standard		
	Antifreeze concentration	Once/Month	Make sure it is set above the concentration		Refer to the physical characteristics of cold-resistance liquid
	Water quality	Once/Month	Within the standard		Refer to water quality furring relations drawing
	Purity	Anytime	The low pressure is within the standard when refrigerating		
			The high pressure is within the standard when heating		
Drainage	Anytime	Drain all the water if it is not used for a long time	Drain water in the distribution pipe		
High and low pressure switch	Action	Once/Month	Check according to "Protection Devices Action ,"	Whether the match point is good	
Pressure Gauge	Finger	Once/ Half of a year	Compare with correct pressure gauge		
Globe valve	Action	Once/Month	Smooth action on globe valve switch		
Refrigeration circle	Refrigeration media leak	Once/Month	Check whether there is refrigeration media leakage inside the unit or at the distribution pipe connecting points. Let out all the water inside the shell-and-tube heat exchanger, and check whether there is any leakage at the water inlet or outlet.	Use the electronic leak detector, or blowtorch leak detector, or soap water.	
Electrical machine control	Insulation resistance	Once/Month	Above $1M\Omega$ is required when testing with DV500V high resistance meter.		
	Wire contact	Once/Month	Insulation layer of the wire must be under good contact condition, without damage, bolt well fixed.		
	Assistant relay	Once/Month	No abnormal action		
	Time-limited relay	Once/Month	Act according to the time set		

Maintenance Safety Requirement

- Each component should be maintained by qualified technicians. Please contact competent maintenance technicians in the event of leakage or breakdown. The safety devices should be checked after each maintenance. Once leakage occurs, all the refrigerant in unit should be pumped out and the leak point should be repaired and then charge the unit with suitable refrigerant according to the nameplate. Some parts on unit can be separated and if the leakage occurs on these parts it is no need to pump out all refrigerant in system.
- Refrigerant type should be ensured according to the nameplate before charging, to charge incorrect refrigerant will result in severe damages.
- Ensure the lubricant type is equivalent with the technical document requirement when charging the lubricant in maintenance.
- Do not vent oxygen to the unit to avoid the violent reaction of oxygen and oil.
- Do not exceed the max. allowed working pressure when unit operates.
- Do not use oxygen for leakage inspection, only refrigerant or dry nitrogen is allowed.
- Do not cut any component or pipes with flames or electrical soldering unless no gas or liquid refrigerant is contained in the unit.
- Toxic gas will be generated when refrigerant contacts with naked flame thus protection should be provided for conveniently available for extinguisher.
- Protection glass should be used for avoiding splashing of refrigerant to skin or eyes. Please use soap and water to clean the refrigerant on skin and if refrigerant splashes into eyes by accident, use water to wash eyes repeatedly and immediately go hospital.
- Do not use naked flame or steam to heat refrigerant containing vessel otherwise over high pressure will result in severe danger. Only mild temperature water can be used if heating refrigerant is needed.
- Do not remove any cover or connection when chiller is operating or with internal pressure. Ensure no internal pressure exist in unit before open any valve which may connected to atmosphere.

If any contamination, corrosion or mechanical damage exists in valves, do not try to repair or reset any safety device. Please replace it when needed.

14 Control System

14.1 PCB Outline and Description

14.1.3 New 30kW module PCB, outlook view (Available for MCCH30A-TA3SL, MCDH30A-TA3SL)

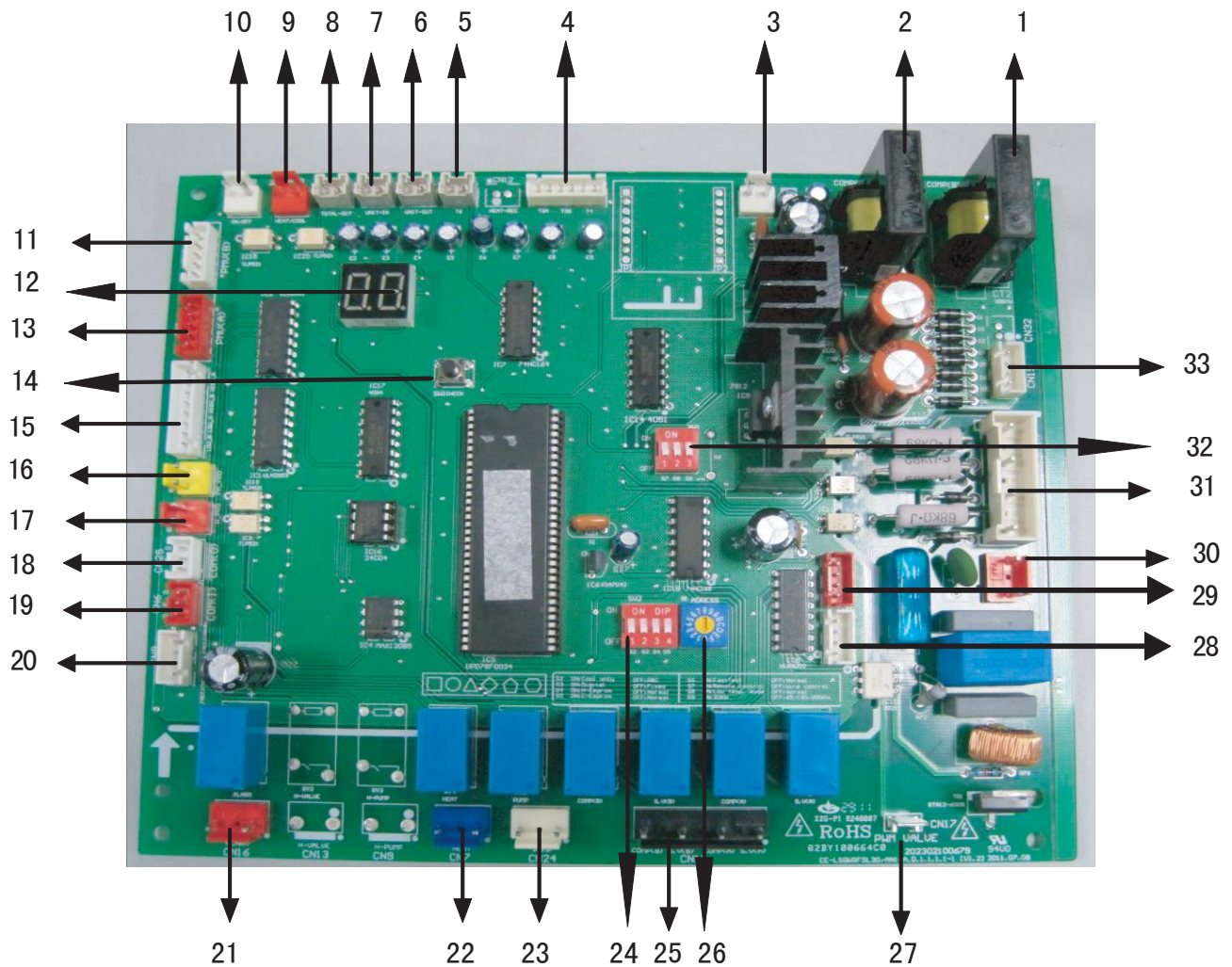



14.1.4 New30kW module components description (Available for MCCH30A-TA3SL, MCDH30A-TA3SL)

No.	Detail information
1	Detection of current of the compressor A1 (Protection code P4).
2	Detection of current of the compressor B1 (Protection code P5). Current is not detected within the initial 5 seconds after the compressor is started up. When the current of the compressor is detected to exceed protective value set (18A for constant speed compressor), it will be shut down and re-started after 3 min.
3	Power port for the current board
4	T4: outdoor ambient temperature sensor (Fault code E7). T3B: pipe temperature sensor of the condenser B (Fault code E6 and protection code P7). T3A: pipe temperature sensor of the condenser A (Fault code E5 and protection code P6). 1) T4: if there is one system that requires starting outdoor fans, the fans are started through electric control of the unit. Start outdoor fan A only, start A and B gears, and control the unit through T4. 2) T3B and T3A: when the electric control of the modular unit detects the temperature of the outdoor pipe T3A or T3B of the system exceeds the protective temperature 65°C, the corresponding system will be shut down. And it will be re-started up, after the temperature drops below the recovery temperature 60°C. Another system will be not affected.

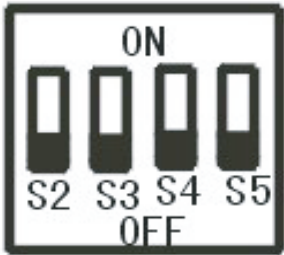
	<p>3) T4, T3B and T3A: when the temperature sensor is detected to suffer open circuit or short circuit, fault alarm will occur.</p> <ul style="list-style-type: none"> ● When the main unit suffer fault of temperature sensor: the main unit and subordinate units will be shut down. ● When the subordinate unit suffer fault of temperature sensor: the unit will be shut down, but other subordinate units will not be affected.
5	Shell and tube low-temperature ant-freeze sensor (Fault code Eb).
6	<p>Unit outlet water temperature sensor (Fault code E4)</p> <p>Under refrigeration mode and heating mode, conduct adjustment according to the magnitude of unit outlet water temperature.</p> <p>Adjustment range of constant speed capability: ON and OFF.</p>
7	Inlet water temperature sensor (Fault code EF).
8	<p>Total outlet water temperature sensor (Fault code E3).</p> <p>Only the main unit is valid, and the subordinate units are invalid.</p> <p>Under refrigerating mode and heating mode, conduct adjustment according to the magnitude of total outlet water temperature. Adjustment range: Load, stabilize, unload, Emergency Stop.</p>
9	<p>1.Dial the code S7 in the main control board to the “ON” position and enter to the remote control mode (The wired controller is invalid).</p> <p>2.First, the ON/OFF port is closed, the second, if this port is closed, the unit enters the heating mode, else, the unit enters the cooling mode. Remote mode control port(ON/OFF signal, effect on NO.0 unit)</p>
10	<p>1) Dial the code S7 in the main control board to the “ON” position and enter to the remote control mode (The wired controller is invalid).</p> <p>Remote control port(ON/OFF signal,effect on NO.0 unit).</p>
11	Electronic expansion valve of the system B
12	<p>Numerical code tube.</p> <p>1) In case of stand-by, the address of the module is displayed.</p> <p>2) In case of normal operation, 10 is displayed (10 is followed by dot).</p> <p>3) In case of fault or protection, fault code or protection code is displayed.</p>
13	<p>Electronic expansion valve in system A.</p> <p>Electronic expansion valve is used to control refrigerant flow under different operating modes and different loads.</p>
14	<p>Spot check. The operating status of outdoor system can be observed through spot check, and specific display contents are as shown in the following figure:</p> <p>● Display contents of “operating mode” : 1. cooling; 2. heating; 4. pump; 8. Stand-by.</p> <p>● Display contents of “number of online units” : the main unit can display the number of online units, and the subordinate unit displays 0.</p>
15	<p>High-pressure protection of the system A and discharge temperature switch protection (Protection code P0).</p> <p>High-pressure protection of the system B and discharge temperature switch protection (Protection code P2).</p> <p>Low-pressure protection of the system A (Protection code P1).</p> <p>Low-pressure protection of the system B (Protection code P3).</p> <p>Constant speed compressor: connection of discharge temperature switch and high-pressure switch of the system in series.</p>
16	Power phase detection(Fault code E8).
17	<p>Water flow detection (Fault code of the main unit E9) is only valid for the main unit but invalid for subordinate units.</p> <p>1) Main unit: if abnormal water flow occurs for the first and second time, the main unit board will display fault code E9.</p>

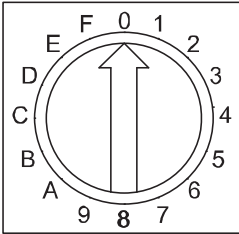
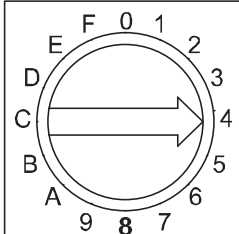
	2) Subordinate unit: (Water flow detection will not be done).
18	<p>COM (I) 485 communication port (Fault code E2).</p> <p>COM (O) is interconnected with P, Q and E of COM (I), used for RS-485 communication.</p> <p>1) If faults occur between the wired controller and the main unit module, all modules will be shut down.</p> <p>2) If faults occur between the main unit and subordinate units, the subordinate unit module suffering communication fault will be shut down. Less units will be detected by the wired controller, which may display EC, and in the meanwhile, the indicator lamp of the wired controller will flash.</p> <p>Restart 3 minutes later after malfunction be removed.</p>
19	COM (O) 485 communication port (Fault code E2).
20	<p>Anti-freezing pressure protection of the system A(Protection code Pc).</p> <p>Anti-freezing pressure protection of the system B(Protection code Pd).</p>
21	The alarm signal output of the unit(ON/OFF signal).
22	<p>Auxiliary electric heater:</p> <p>Attention: the control port value of auxiliary electric heater actually detected is ON/OFF but not 220-240V control power supply, so special attention should be paid when installing the auxiliary electric heater.</p> <p>Attention!</p> <p>Under heating mode, when the main unit board detects total water outlet temperature to be lower than 45℃, the switch will be closed, and the auxiliary electric heater will begin to work; when the total water outlet temperature is higher than 50℃, the switch will be opened, and the auxiliary electric heater will stop working.</p>
23	<p>PUMP:</p> <p>Attention: the control port value of the pump actually detected is ON/OFF but not 220-240V control power supply, so special attention should be paid when installing the pump.</p> <p>1) After receiving start-up instruction, the pump will be started up instantly, and will maintain start-up state always in the process of operation.</p> <p>2) In case of refrigerating or heating shutdown, the pump will be shut down 2 minutes after all modules stop operating.</p> <p>3) In case of shutdown under the pump mode, the pump can be directly shut down.</p>
24	 <p>S2 ON: Cooling only OFF: R&C</p> <p>S3 ON: Digital OFF: Fixed</p> <p>S4 ON:H-EEPROM OFF: Normal</p> <p>S5 ON:C-EEPROM OFF: Normal</p>
25	<p>One compressor in system B.</p> <p>Four-way valve in system B.</p> <p>One compressor in system A.</p> <p>Four-way valve in system A.</p>

26	 <p>ADDRRSS</p>	When the address is 0, it serves as the main unit.
	 <p>ADDRRSS</p>	When the address is 1,2,3.....F, it serves as the subordinate unit 1,2,3.....15.
<p>Each modular part of modular unit has the same electric control function, and the main unit and subordinate units can be set through address code on the electric control board. The address code 0 # is provided as the main unit. The priority of being the main unit is given to the unit with digital compressor, and other addresses are subordinate units. Only the unit is chosen as the main unit, its electric control can activate such functions as direct communication with the wired controller, refrigerating and heating capability adjustment, pump control, auxiliary electric heater control, total effluent temperature detection and water flow switch detection.</p>		
27	PWM pressure relieve valve control(For digital compressor).	
28	Outdoor fan A, controlled by T4.	
29	Outdoor fan B, controlled by T4.	
30	Input of transformer, 220-240V AC current. (Only valid for the main unit).	
31	<p>Input of three-phase four-wire power supply (Fault code E1).</p> <p>Three phases A, B and C of power supply should exist simultaneously, and the difference of phase angle should be 120° among them. If the conditions are not met, fault of phase sequence or phase lack may occur, and fault code will be displayed. When the power supply returns to normal condition, fault is removed. Attention: phase lace and phase dislocation of power supply are detected only in the early period after the power supply is connected, and they are not detected while the unit is in operation.</p>	
32		<p>S7 ON: Remote control OFF: Wired control</p> <p>S8 ON: Low temp. mode OFF: Normal</p> <p>S9 ON:30KW OFF: 65/130/200/260KW</p>
33	Output of transformer	

1. Faults

When the main unit suffers faults, the main unit stops operating, and all other units also stop running;
When the subordinate unit suffers faults, only the unit stops operating, and other units are not affected.

2. Protection

When the main unit is under protection, only the unit stops operating, and other units keep running;
When the subordinate unit is under protection, only the unit stops operating, and other units are not affected.

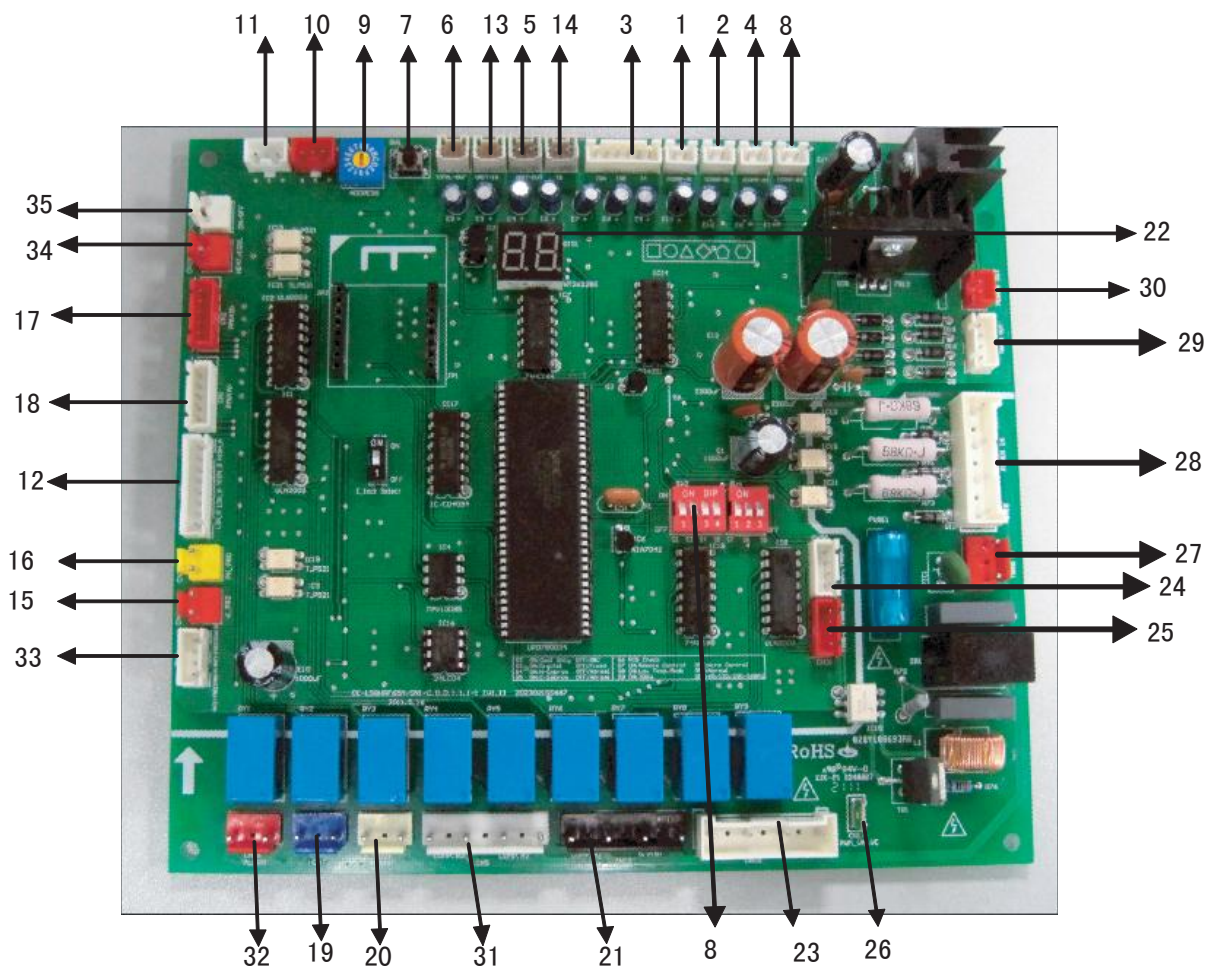
MCCD65A-SA3L outlook view:**MGBL-D65W/RN1 module components description:**

No.	Detail information
1	Detection of current of the compressor A1 (Protection code P4).
2	Detection of current of the compressor B1 (Protection code P5). Current is not detected within the initial 5 seconds after the compressor is started up. When the current of the compressor is detected to exceed protective value set (33A for constant speed compressor), it will be shut down and re-started after 3 min.
3	T4: outdoor ambient temperature sensor (Fault code E7). T3B: pipe temperature sensor of the condenser B (Fault code E6 and protection code P7). T3A: pipe temperature sensor of the condenser A (Fault code E5 and protection code P6). 1) T4: if there is one system that requires starting outdoor fans, the fans are started through electric control of the unit. Start outdoor fan A only, start A and B gears, and control the unit through T4. 2) T3B and T3A: when the electric control of the modular unit detects the temperature of the outdoor pipe T3A or T3B of the system exceeds the protective temperature 65°C, the corresponding system will be shut down. And it will be re-started up, after the temperature drops below the recovery temperature 60°C. Another system will be not affected. 3) T4, T3B and T3A: when the temperature sensor is detected to suffer open circuit or short circuit, fault alarm will occur. ● When the main unit suffer fault of temperature sensor: the main unit and subordinate units will be shut down. ● When the subordinate unit suffer fault of temperature sensor: the unit will be shut down, but other subordinate units will not be affected.
4	Detection of current of the compressor A2 (Protection code P4).
5	Unit outlet water temperature sensor (Fault code E4). Under refrigeration mode and heating mode, conduct adjustment according to the magnitude of unit outlet water temperature.

	Adjustment range of constant speed capability: ON and OFF. Adjustment range of constant speed capability: ON and OFF.
6	<p>Total outlet water temperature sensor (Fault code E3).</p> <p>Only the main unit is valid, and the subordinate units are invalid.</p> <p>Under refrigerating mode and heating mode, conduct adjustment according to the magnitude of total outlet water temperature. Adjustment range: Load, stabilize, unload, Emergency Stop.</p>
7	<p>Spot check. The operating status of outdoor system can be observed through spot check, and specific display contents are as shown in the following figure:</p> <ul style="list-style-type: none"> • Display contents of “operating mode”: 1. cooling; 2. heating; 4. pump; 8. Stand-by. • Display contents of “number of online units”: the main unit can display the number of online units, and the slave unit displays 0.
8	<p>Factory setting.</p>
9	<p>When the address is 0, it serves as the main unit.</p> <p>When the address is 1,2,3.....F, it serves as the subordinate unit 1,2,3.....15.</p> <p>Each modular part of modular unit has the same electric control function, and the main unit and subordinate units can be set through address code on the electric control board. The address code 0 # is provided as the main unit. The priority of being the main unit is given to the unit with digital compressor, and other addresses are subordinate units. Only the unit is chosen as the main unit, its electric control can activate such functions as direct communication with the wired controller, refrigerating and heating capability adjustment, pump control, auxiliary electric heater control, total effluent temperature detection and water flow switch detection.</p>
10	COM (O) 485 communication port (Fault code E2).
11	<p>COM (I) 485 communication port (Fault code E2).</p> <p>COM (O) is interconnected with P, Q and E of COM (I), used for RS-485 communication.</p> <p>1) If faults occur between the wired controller and the main unit module, all modules will be shut down.</p>

	2) If faults occur between the main unit and subordinate units, the subordinate unit module suffering communication fault will be shut down. Less units will be detected by the wired controller, which may display EA, and in the meanwhile, the indicator lamp of the wired controller will flash, restart 3 minutes later after malfunction be removed.
12	High-pressure protection of the system A and discharge temperature switch protection (Protection code P0). High-pressure protection of the system B and discharge temperature switch protection (Protection code P2). Low-pressure protection of the system A (Protection code P1). Low-pressure protection of the system B (Protection code P3). Constant speed compressor: connection of discharge temperature switch and high-pressure switch of the system in series.
13	Inlet water temperature sensor (Fault code EF).
14	Shell and tube low-temperature ant-freezing sensor (Fault code Eb).
15	Water flow detection (Fault code of the main unit E9) is only valid for the main unit but invalid for subordinate units. 1) Main unit: if abnormal water flow occurs , the main unit board and the wired controller will display fault code E9. 2) Subordinate unit: (Water flow detection will not be done).
16	Power phase detection(Fault code E8).
17	Electronic expansion valve of the system B.
18	Electronic expansion valve of the system A. Electronic expansion valve is used to control refrigerant flow under different operating modes and different loads.
19	Auxiliary electric heater. Attention: the control port value of auxiliary electric heater actually detected is ON/OFF but not 220-240V control power supply, so special attention should be paid when installing the auxiliary electric heater. Attention! Under heating mode, when the main unit board detects total water outlet temperature to be lower than 45℃, the switch will be closed, and the auxiliary electric heater will begin to work; when the total water outlet temperature is higher than 50℃, the switch will be opened, and the auxiliary electric heater will stop working.
20	PUMP. Attention: the control port value of the pump actually detected is ON/OFF but not 220-240V control power supply, so special attention should be paid when installing the pump. 1) After receiving start-up instruction, the pump will be started up instantly, and will maintain start-up state always in the process of operation. 2) In case of refrigerating or heating shutdown, the pump will be shut down 2 minutes after all modules stop operating. 3) In case of shutdown under the pump mode, the pump can be directly shut down.
21	One compressor of the system B(B1). Neutral wire. Four-way valve of the system B. Neutral wire.
22	Numerical code tube. 1) In case of stand-by, the address of the module is displayed. 2) In case of normal operation, 10. is displayed (10 is followed by dot). 3) In case of fault or protection, fault code or protection code is displayed.
23	One compressor of the system A(A1). Neutral wire. Four-way valve of the system A. Neutral wire.
24	Outdoor fan A, controlled by T4.
25	Outdoor fan B, controlled by T4.
26	PWM pressure relieve valve control(for digital compressor).
27	Input of transformer, 220-230V AC current. (Only valid for the main unit).

28	<p>Input of three-phase four-wire power supply (Fault code E1).</p> <p>Three phases A, B and C of power supply should exist simultaneously, and the difference of phase angle should be 120° among them. If the conditions are not met, fault of phase sequence or phase lack may occur, and fault code will be displayed. When the power supply returns to normal condition, fault is removed. Attention: phase lack and phase dislocation of power supply are detected only in the early period after the power supply is connected, and they are not detected while the unit is in operation.</p>
29	Output of transformer.
30	Power port for the current board.
31	<p>One compressor of the system B(B2).</p> <p>Neutral wire.</p> <p>One compressor of the system A(A2).</p> <p>Neutral wire.</p>
32	The alarm signal output of the unit(ON/OFF signal)
33	<p>Anti-freezing pressure protection of the system A(Protection code Pc)</p> <p>Anti-freezing pressure protection of the system B(Protection code Pd)</p>
34	<p>Remote control port(ON/OFF signal, effect on NO.0 unit)</p> <p>1.Dial the code S7 in the main control board to the "ON" position and enter to the remote control mode (the wired controller is invalid)</p> <p>2.If the port is closed, the unit is turned on, else, the unit is turned off.</p>
35	<p>Remote mode control port(ON/OFF signal effect on NO.0 unit)</p> <p>1.Dial the code S7 in the main control board to the "ON" position and enter to the remote control mode (The wired controller is invalid).</p> <p>2.First, the ON/OFF port is closed. Second, if this port is closed, the unit enters the heating mode, else, the unit enters the cooling mode.</p>

CAUTION

1. Faults

When the main unit suffers faults, the main unit stops operating, and all other units also stop running;

When the subordinate unit suffers faults, only the unit stops operating, and other units are not affected.

2. Protection

When the main unit is under protection, only the unit stops operating, and other units keep running;

When the subordinate unit is under protection, only the unit stops operating, and other units are not affected.

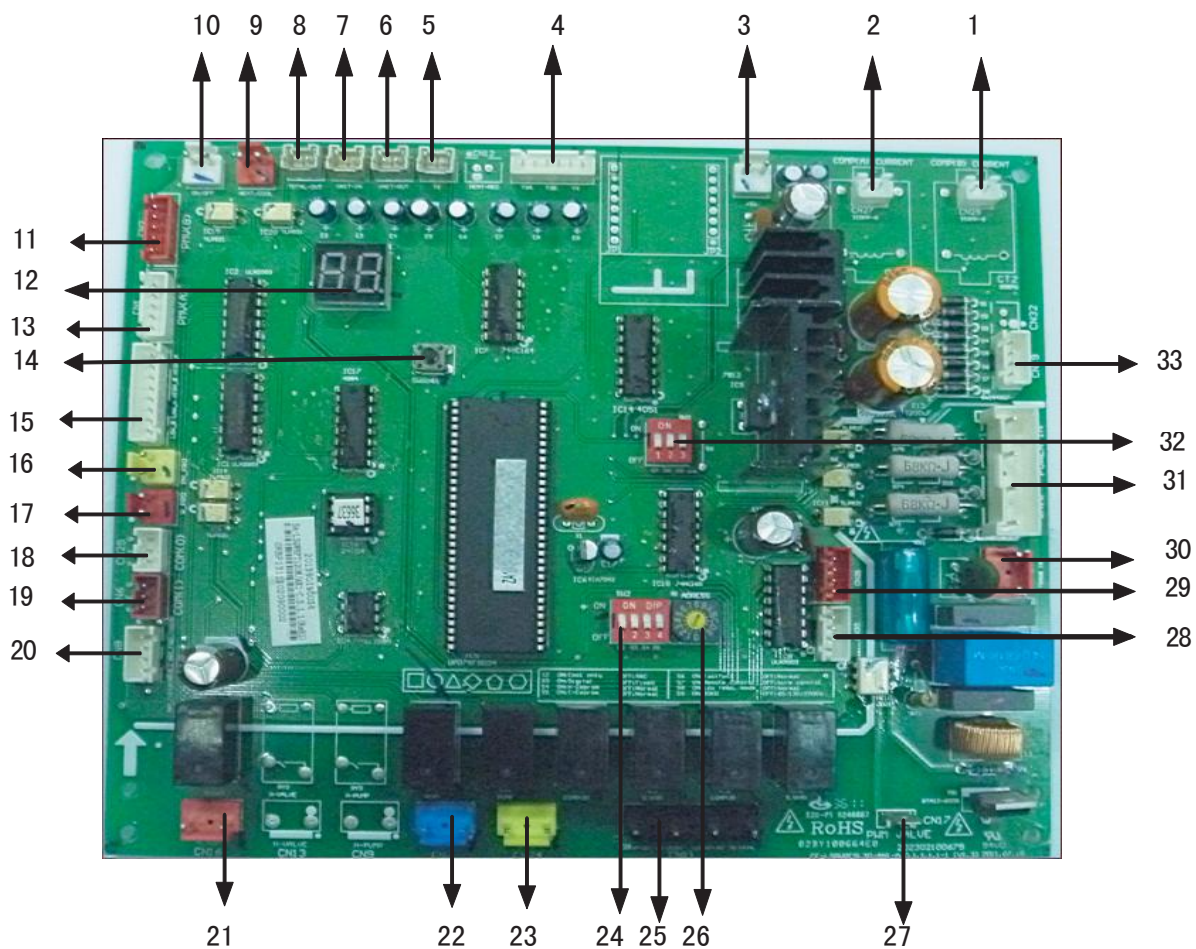
MCCH65A-SA3L outlook view**MCCH65A-SA3L module components description**

No.	Detail information
1	Detection of current of the compressor A1 (Protection code P4).
2	Detection of current of the compressor B1 (Protection code P5). Current is not detected within the initial 5 seconds after the compressor is started up. When the current of the compressor is detected to exceed protective value set (33A for constant speed compressor), it will be shut down and re-started after 3 min.
3	Power port for the current board.
4	T4: outdoor ambient temperature sensor (Fault code E7). T3B: pipe temperature sensor of the condenser B (Fault code E6 and protection code P7). T3A: pipe temperature sensor of the condenser A (Fault code E5 and protection code P6). 1) T4: if there is one system that requires starting outdoor fans, the fans are started through electric control of the unit. Start outdoor fan A only, start A and B gears, and control the unit through T4. 2) T3B and T3A: when the electric control of the modular unit detects the temperature of the outdoor pipe T3A or T3B of the system exceeds the protective temperature 65°C, the corresponding system will be shut down. And it will be re-started up, after the temperature drops below the recovery temperature 60°C. Another system will be not affected. 3) T4, T3B and T3A: when the temperature sensor is detected to suffer open circuit or short circuit, fault alarm will occur. ● When the main unit suffer fault of temperature sensor: the main unit and subordinate units will be shut down. ● When the subordinate unit suffer fault of temperature sensor: the unit will be shut down, but other subordinate units will not be affected.
5	Shell and tube low-temperature ant-freezing sensor (Fault code Eb).
6	Unit outlet water temperature sensor (Fault code E4). Under refrigeration mode and heating mode, conduct adjustment according to the magnitude of unit outlet water temperature.

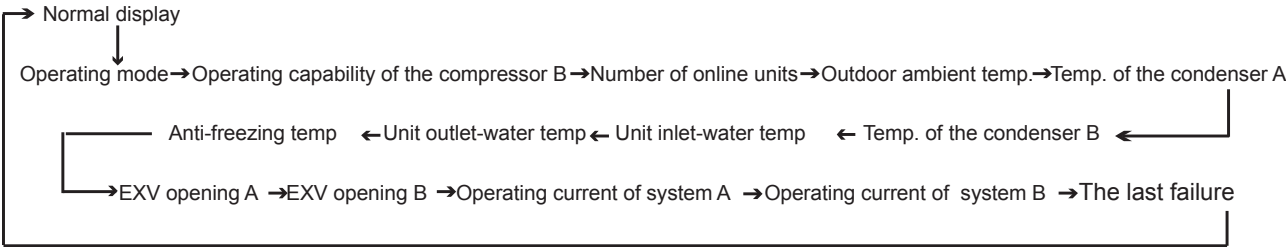
	Adjustment range of constant speed capability: ON and OFF. Adjustment range of constant speed capability: ON and OFF.
7	Inlet water temperature sensor (Fault code EF).
8	Total outlet water temperature sensor (Fault code E3). Only the main unit is valid, and the subordinate units are invalid. Under refrigerating mode and heating mode, conduct adjustment according to the magnitude of total outlet water temperature. Adjustment range: Load, stabilize, unload, Emergency Stop.
9	Remote mode control port(ON/OFF signal, effect on NO.0 unit). 1.Dial the code S7 in the main control board to the "ON" position and enter to the remote control mode (The wired controller is invalid). 2.First, the ON/OFF port is closed, second, if this port is closed, the unit enters the heating mode, else, the unit enters the cooling mode.
10	Remote mode control port(ON/OFF signal, effect on NO.0 unit). 1.Dial the code S7 in the main control board to the "ON" position and enter to the remote control mode (The wired controller is invalid) 2. If the port is closed, the unit is turned on, else, the unit is turned off.
11	Electronic expansion valve of the system B.
12	Numerical code tube. 1) In case of stand-by, the address of the module is displayed. 2) In case of normal operation, 10. Is displayed (10 is followed by dot). 3) In case of fault or protection, fault code or protection code is displayed.
13	Electronic expansion valve of the system A. Electronic expansion valve is used to control refrigerant flow under different operating modes and different loads.
14	Spot check. The operating status of outdoor system can be observed through spot check, and specific display contents are as shown in the following figure:  <ul style="list-style-type: none"> • Display contents of "operating mode": 1. cooling; 2. heating; 4. pump; 8. Stand-by. • Display contents of "number of online units": the main unit can display the number of online units, and the slave unit displays 0.
15	High-pressure protection of the system A and discharge temperature switch protection (Protection code P0). High-pressure protection of the system B and discharge temperature switch protection (Protection code P2). Low-pressure protection of the system A (Protection code P1). Low-pressure protection of the system B (Protection code P3). Constant speed compressor: connection of discharge temperature switch and high-pressure switch of the system in series.
16	Power phase detection(Fault code E8).
17	Water flow detection (Fault code of the main unit E9) is only valid for the main unit but invalid for subordinate units. 1) Main unit: if abnormal water flow occurs for the first and second time, the main unit board will display fault code E9. 2) Subordinate unit: (Water flow detection will not be done).
18	COM (I) 485 communication port (Fault code E2). COM (O) is interconnected with P, Q and E of COM (I), used for RS-485 communication. 1) If faults occur between the wired controller and the main unit module, all modules will be shut down. 2) If faults occur between the main unit and subordinate units, the subordinate unit module suffering communication fault will be shut down. Less units will be detected by the wired controller, which may display EC, and in the meanwhile, the indicator lamp of the wired controller will flash. Restart 3 minutes later after malfunction be removed.

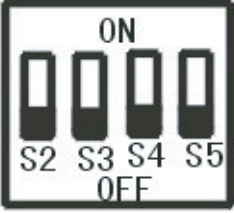
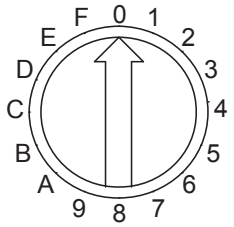
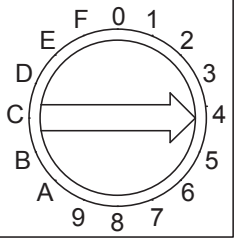
19	COM (O) 485 communication port (Fault code E2).
20	Anti-freezing pressure protection of the system A(Protection code Pc). Anti-freezing pressure protection of the system B(Protection code Pd).
21	The alarm signal output of the unit(ON/OFF signal).
22	<p>Auxiliary electric heater: Attention: the control port value of auxiliary electric heater actually detected is ON/OFF but not 220-240V control power supply, so special attention should be paid when installing the auxiliary electric heater.</p> <p>Attention! Under heating mode, when the main unit board detects total water outlet temperature to be lower than 45℃, the switch will be closed, and the auxiliary electric heater will begin to work; when the total water outlet temperature is higher than 50℃, the switch will be opened, and the auxiliary electric heater will stop working.</p>
23	<p>PUMP: Attention: the control port value of the pump actually detected is ON/OFF but not 220-240V control power supply, so special attention should be paid when installing the pump.</p> <p>1) After receiving start-up instruction, the pump will be started up instantly, and will maintain start-up state always in the process of operation. 2) In case of refrigerating or heating shutdown, the pump will be shut down 2 minutes after all modules stop operating. 3) In case of shutdown under the pump mode, the pump can be directly shut down.</p>
24	<p>Factory setting</p>  <p>S2 ON: Cooling only OFF: R&C S3 ON: Digital OFF: Fixed S4 ON:H-EEprom OFF: Normal S5 ON:C-Eeprom OFF: Normal</p>
25	<p>One compressor of the system B. Four-way valve of the system B. One compressor of the system A. Four-way valve of the system A.</p>
26	 <p>ADDRSS</p> <p>When the address is 0, it serves as the main unit.</p>  <p>ADDRSS</p> <p>When the address is 1,2,3.....F, it serves as the subordinate unit 1,2,3.....15.</p> <p>Each modular part of modular unit has the same electric control function, and the main unit and subordinate units can be set</p>

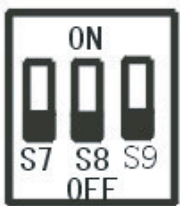
	through address code on the electric control board. The address code 0 # is provided as the main unit. The priority of being the main unit is given to the unit with digital compressor, and other addresses are subordinate units. Only the unit is chosen as the main unit, its electric control can activate such functions as direct communication with the wired controller, refrigerating and heating capability adjustment, pump control, auxiliary electric heater control, total effluent temperature detection and water flow switch detection.
27	PWM pressure relieve valve control(For digital compressor).
28	Outdoor fan A, controlled by T4.
29	Outdoor fan B, controlled by T4.
30	Input of transformer, 220-240V AC current. (Only valid for the main unit).
31	Input of three-phase four-wire power supply (Fault code E1). Three phases A, B and C of power supply should exist simultaneously, and the difference of phase angle should be 120° among them. If the conditions are not met, fault of phase sequence or phase lack may occur, and fault code will be displayed. When the power supply returns to normal condition, fault is removed. Attention: phase lace and phase dislocation of power supply are detected only in the early period after the power supply is connected, and they are not detected while the unit is in operation.
32	 <p>S7 ON: Remote control OFF: Wired control S8 ON: Low temp. Mode OFF: Normal S9 ON: 30KW OFF: 65/130/200/250KW</p>
33	Output of transformer.

CAUTION

1. Faults

When the main unit suffers faults, the main unit stops operating, and all other units also stop running;

When the subordinate unit suffers faults, only the unit stops operating, and other units are not affected.

2. Protection

When the main unit is under protection, only the unit stops operating, and other units keep running;

When the subordinate unit is under protection, only the unit stops operating, and other units are not affected.

MCCH130A-SA3L outlook view

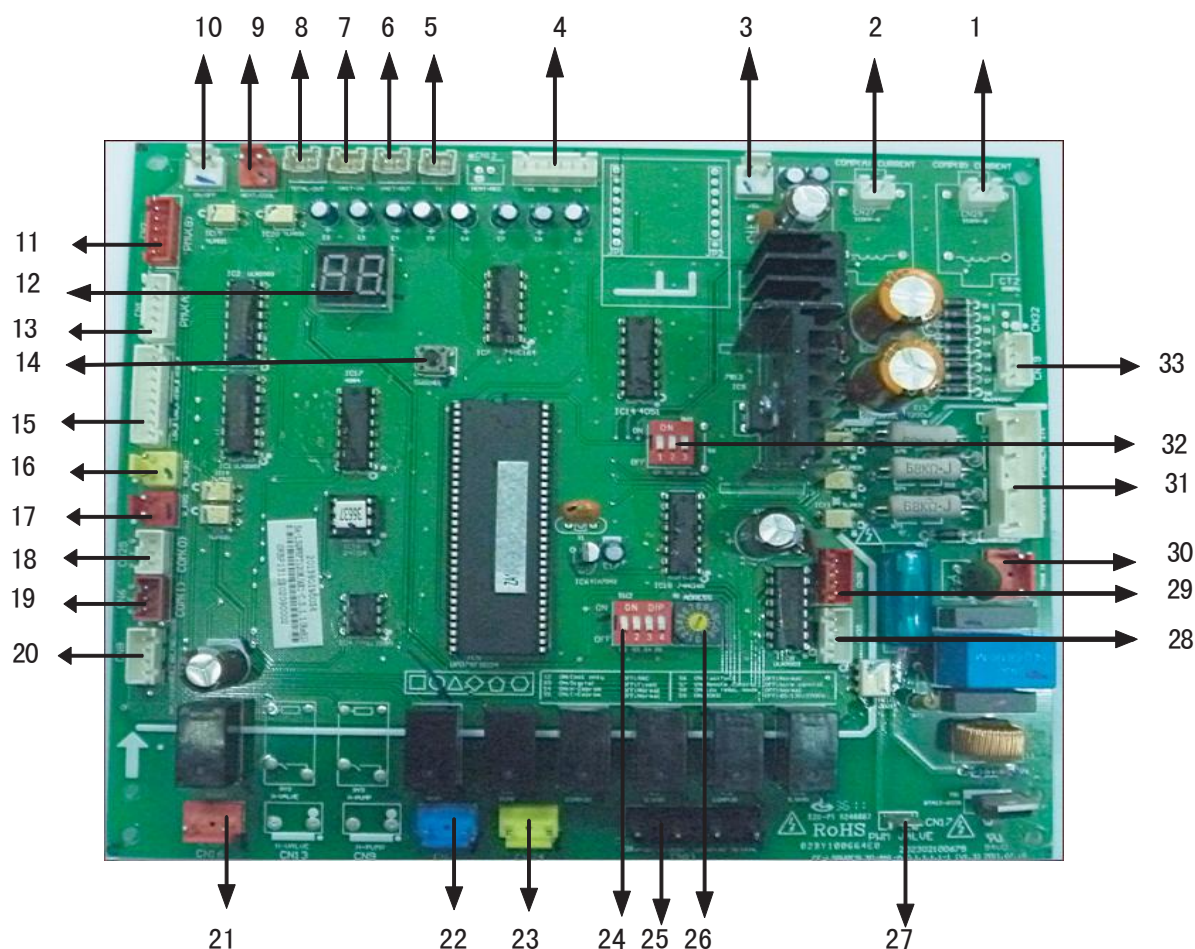

MCCH130A-SA3L module components description

No.	Detail information
1	Detection of current of the compressor A1 (Protection code P4).
2	Detection of current of the compressor B1 (Protection code P5). Current is not detected within the initial 5 seconds after the compressor is started up. When the current of the compressor is detected to exceed protective value set (33A for constant speed compressor), it will be shut down and re-started after 3 min.
3	Power port for the current board.
4	T4: outdoor ambient temperature sensor (Fault code E7). T3B: pipe temperature sensor of the condenser B (Fault code E6 and protection code P7). T3A: pipe temperature sensor of the condenser A (Fault code E5 and protection code P6). 1) T4: if there is one system that requires starting outdoor fans, the fans are started through electric control of the unit. Start outdoor fan A only, start A and B gears, and control the unit through T4. 2) T3B and T3A: when the electric control of the modular unit detects the temperature of the outdoor pipe T3A or T3B of the system exceeds the protective temperature 65°C, the corresponding system will be shut down. And it will be re-started up, after the temperature drops below the recovery temperature 60°C. Another system will be not affected. 3) T4, T3B and T3A: when the temperature sensor is detected to suffer open circuit or short circuit, fault alarm will occur. ● When the main unit suffer fault of temperature sensor: the main unit and subordinate units will be shut down. ● When the subordinate unit suffer fault of temperature sensor: the unit will be shut down, but other subordinate units will not be affected.
5	Shell and tube low-temperature ant-freezing sensor (Fault code Eb).
6	Unit outlet water temperature sensor (Fault code E4). Under refrigeration mode and heating mode, conduct adjustment according to the magnitude of unit outlet water temperature.

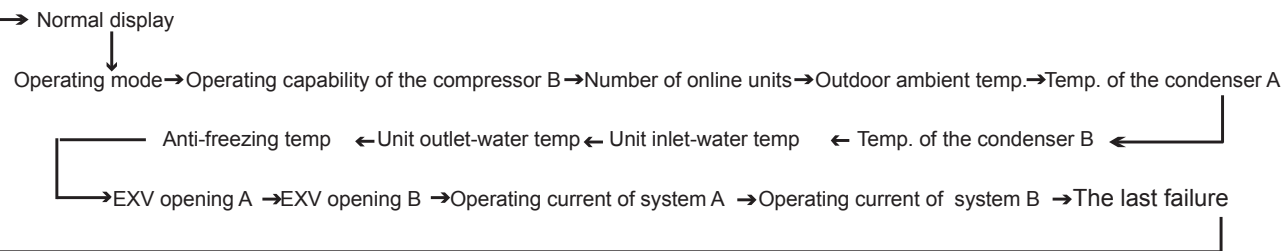
	Adjustment range of constant speed capability: ON and OFF. Adjustment range of constant speed capability: ON and OFF.
7	Inlet water temperature sensor (Fault code EF).
8	Total outlet water temperature sensor (Fault code E3). Only the main unit is valid, and the subordinate units are invalid. Under refrigerating mode and heating mode, conduct adjustment according to the magnitude of total outlet water temperature. Adjustment range: Load, stabilize, unload, Emergency Stop.
9	Remote mode control port(ON/OFF signal, effect on NO.0 unit). 1.Dial the code S7 in the main control board to the "ON" position and enter to the remote control mode (The wired controller is invalid). 2.First, the ON/OFF port is closed, second, if this port is closed, the unit enters the heating mode, else, the unit enters the cooling mode.
10	Remote mode control port(ON/OFF signal, effect on NO.0 unit). 1.Dial the code S7 in the main control board to the "ON" position and enter to the remote control mode (The wired controller is invalid) 2. If the port is closed, the unit is turned on, else, the unit is turned off.
11	Electronic expansion valve of the system B.
12	Numerical code tube. 1) In case of stand-by, the address of the module is displayed. 2) In case of normal operation, 10. Is displayed (10 is followed by dot). 3) In case of fault or protection, fault code or protection code is displayed.
13	Electronic expansion valve of the system A. Electronic expansion valve is used to control refrigerant flow under different operating modes and different loads.
14	Spot check. The operating status of outdoor system can be observed through spot check, and specific display contents are as shown in the following figure:  <ul style="list-style-type: none"> • Display contents of "operating mode": 1. cooling; 2. heating; 4. pump; 8. Stand-by. • Display contents of "number of online units": the main unit can display the number of online units, and the slave unit displays 0.
15	High-pressure protection of the system A and discharge temperature switch protection (Protection code P0). High-pressure protection of the system B and discharge temperature switch protection (Protection code P2). Low-pressure protection of the system A (Protection code P1). Low-pressure protection of the system B (Protection code P3). Constant speed compressor: connection of discharge temperature switch and high-pressure switch of the system in series.
16	Power phase detection(Fault code E8).
17	Water flow detection (Fault code of the main unit E9) is only valid for the main unit but invalid for subordinate units. 1) Main unit: if abnormal water flow occurs for the first and second time, the main unit board will display fault code E9. 2) Subordinate unit: (Water flow detection will not be done).
18	COM (I) 485 communication port (Fault code E2). COM (O) is interconnected with P, Q and E of COM (I), used for RS-485 communication. 1) If faults occur between the wired controller and the main unit module, all modules will be shut down. 2) If faults occur between the main unit and subordinate units, the subordinate unit module suffering communication fault will be shut down. Less units will be detected by the wired controller, which may display EC, and in the meanwhile, the indicator lamp of the wired controller will flash. Restart 3 minutes later after malfunction be removed.

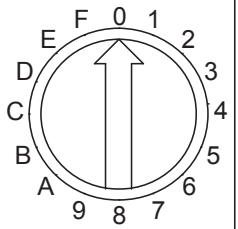
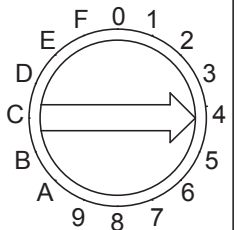
19	COM (O) 485 communication port (Fault code E2).
20	Anti-freezing pressure protection of the system A(Protection code Pc). Anti-freezing pressure protection of the system B(Protection code Pd).
21	The alarm signal output of the unit(ON/OFF signal).
22	Auxiliary electric heater: Attention: the control port value of auxiliary electric heater actually detected is ON/OFF but not 220-240V control power supply, so special attention should be paid when installing the auxiliary electric heater. Attention! Under heating mode, when the main unit board detects total water outlet temperature to be lower than 45℃, the switch will be closed, and the auxiliary electric heater will begin to work; when the total water outlet temperature is higher than 50℃, the switch will be opened, and the auxiliary electric heater will stop working.
23	PUMP: Attention: the control port value of the pump actually detected is ON/OFF but not 220-240V control power supply, so special attention should be paid when installing the pump. 1) After receiving start-up instruction, the pump will be started up instantly, and will maintain start-up state always in the process of operation. 2) In case of refrigerating or heating shutdown, the pump will be shut down 2 minutes after all modules stop operating. 3) In case of shutdown under the pump mode, the pump can be directly shut down.
24	Factory setting  S2 ON: Cooling only OFF: R&C S3 ON: Digital OFF: Fixed S4 ON:H-EEprom OFF: Normal S5 ON:C-Eeprom OFF: Normal
25	One compressor of the system B. Four-way valve of the system B. One compressor of the system A. Four-way valve of the system A.
26	 <p>When the address is 0, it serves as the main unit.</p>  <p>When the address is 1,2,3.....F, it serves as the subordinate unit 1,2,3.....15.</p> <p>Each modular part of modular unit has the same electric control function, and the main unit and subordinate units can be set</p>

	through address code on the electric control board. The address code 0 # is provided as the main unit. The priority of being the main unit is given to the unit with digital compressor, and other addresses are subordinate units. Only the unit is chosen as the main unit, its electric control can activate such functions as direct communication with the wired controller, refrigerating and heating capability adjustment, pump control, auxiliary electric heater control, total effluent temperature detection and water flow switch detection.
27	PWM pressure relieve valve control(For digital compressor).
28	Outdoor fan A, controlled by T4.
29	Outdoor fan B, controlled by T4.
30	Input of transformer, 220-240V AC current. (Only valid for the main unit).
31	Input of three-phase four-wire power supply (Fault code E1). Three phases A, B and C of power supply should exist simultaneously, and the difference of phase angle should be 120° among them. If the conditions are not met, fault of phase sequence or phase lack may occur, and fault code will be displayed. When the power supply returns to normal condition, fault is removed. Attention: phase lace and phase dislocation of power supply are detected only in the early period after the power supply is connected, and they are not detected while the unit is in operation.
32	 <p>S7 ON: Remote control OFF: Wired control S8 ON: Low temp. Mode OFF: Normal S9 ON: 30KW OFF: 65/130/200/250KW</p>
33	Output of transformer.

CAUTION

1. Faults

When the main unit suffers faults, the main unit stops operating, and all other units also stop running;

When the subordinate unit suffers faults, only the unit stops operating, and other units are not affected.

2. Protection

When the main unit is under protection, only the unit stops operating, and other units keep running;

When the subordinate unit is under protection, only the unit stops operating, and other units are not affected.

14.1.9 185 kW Module PCB, outlook view

Electric control schematic diagram of the unit

- 1 Electric control diagram of the main unit and subordinate units (see Attached Drawing (I))
- 2 Schematic diagram of connection and communication of the main unit and subordinate units (see Attached Drawing (II))
- 3 Indicating diagram of electric control of main control board (see Fig.5-4)

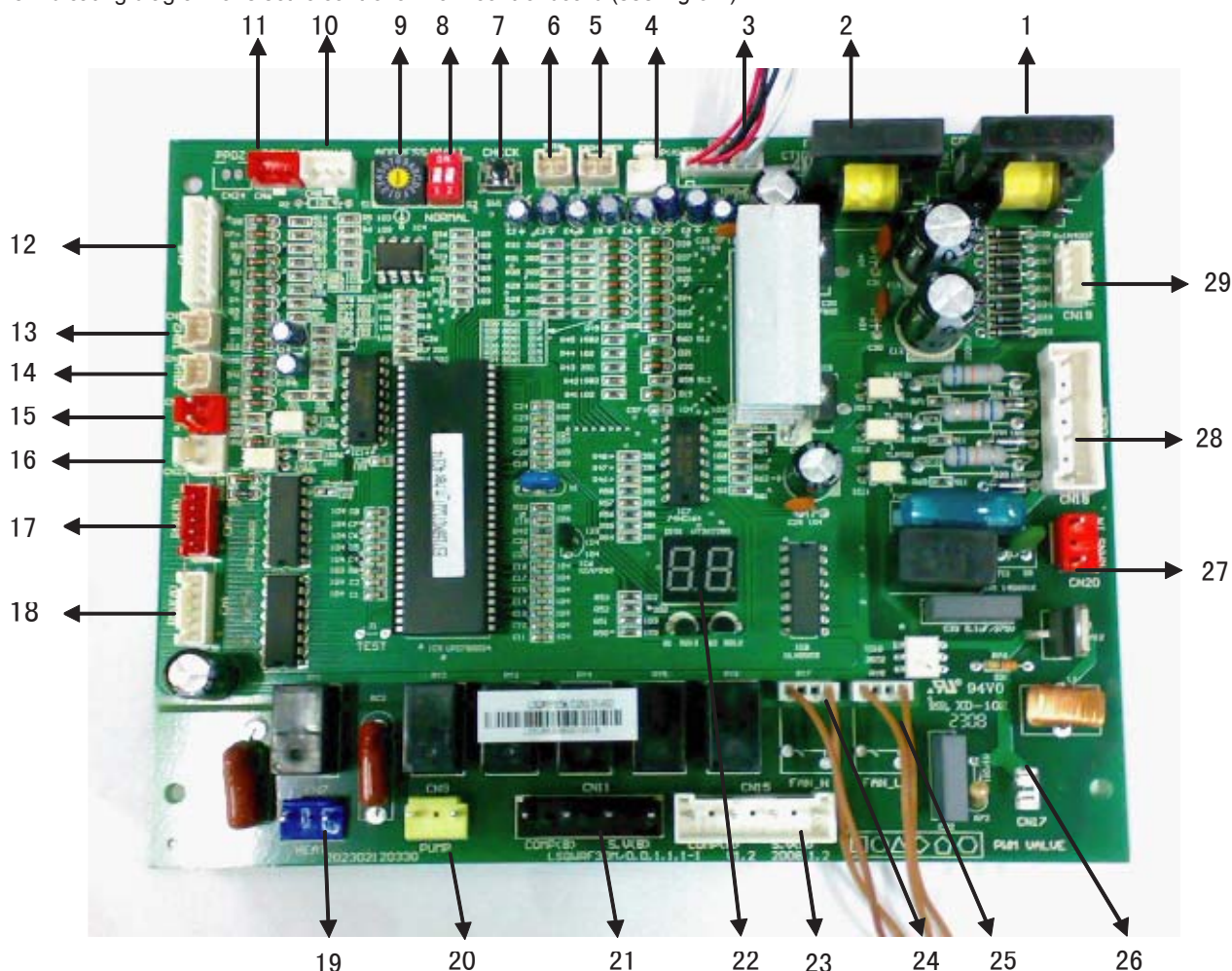

14.1.10 185 kW module components description

No	Detail information
1	Detection of current of the compressor B (Protection code P5).
2	Detection of current of the compressor A (Protection code P4). Current is not detected within the initial 5 seconds after the compressor is started up. When the current of the compressor is detected to exceed protective value set (33A for constant speed compressor), it will be shut down and re-started after 3 min.
3	T4: outdoor ambient temperature sensor (Fault code E7). T3B: pipe temperature sensor of the condenser B (Fault code E6 and protection code P7). T3A: pipe temperature sensor of the condenser A (Fault code E5 and protection code P6). 1) T4: if there is one system that requires starting outdoor fans, the fans are started through electric control of the unit. Start outdoor fan A only, start A and B gears, and control the unit through T4. 2) T3B and T3A: when the electric control of the modular unit detects the temperature of the outdoor pipe T3A or T3B of the system exceeds the protective temperature 65°C, the corresponding system will be shut down. And it will be re-started up, after the temperature drops below the recovery temperature 60°C. Another system will be not affected. 3) T4, T3B and T3A: when the temperature sensor is detected to suffer open circuit or short circuit, fault alarm will occur. ● When the main unit suffer fault of temperature sensor: the main unit and subordinate units will be shut down. ● When the subordinate unit suffer fault of temperature sensor: the unit will be shut down, but other subordinate units will not be affected.
4	(Reserved)
5	Unit outlet water temperature sensor (Fault code E4). Under refrigeration mode and heating mode, conduct adjustment according to the magnitude of unit outlet water temperature. Adjustment range of constant speed capability: ON and OFF.

6	<p>Total outlet water temperature sensor (Fault code E3). Only the main unit is valid, and the subordinate units are invalid. Under refrigerating mode and heating mode, conduct adjustment according to the magnitude of total outlet water temperature. Adjustment range: Load, stabilize, unload, Emergency Stop.</p>
7	<p>Spot check. The operating status of outdoor system can be observed through spot check, and specific display contents are as shown in the following figure:</p> <ul style="list-style-type: none"> • Display contents of "operating mode": 1. cooling; 2. heating; 4. pump; 8. Stand-by • Display contents of "number of online units": the main unit can display the number of online units, and the subordinate unit displays 0.
8	<p style="text-align: center;">Selection code of the compressor</p> <div style="display: flex; justify-content: space-around;"> <div style="text-align: center;"> <p>DIGIT</p> <p>NORMAL</p> </div> <div style="border: 1px solid black; padding: 5px;">Reserved DIP switch state</div> </div> <div style="display: flex; justify-content: space-around; margin-top: 20px;"> <div style="text-align: center;"> <p>DIGIT</p> <p>NORMAL</p> </div> <div style="border: 1px solid black; padding: 5px;">The diagram denotes selection of constant speed compressor</div> </div>
9	<div style="display: flex; justify-content: space-between;"> <div style="width: 45%;"> <p>ADDRRSS</p> <p>When the address is 0, it serves as the main unit.</p> </div> <div style="width: 45%;"> <p>Each modular part of modular unit has the same electric control function, and the main unit and subordinate units can be set through address code on the electric control board. The address code 0 # is provided as the main unit. The priority of being the main unit is given to the unit with digital compressor, and other addresses are subordinate units. Only the unit is chosen as the main unit, its electric control can activate such functions as direct communication with the wired controller, refrigerating and heating capability adjustment, pump control, auxiliary electric heater control, total effluent temperature detection and water flow switch detection.</p> </div> </div> <div style="display: flex; justify-content: space-between; margin-top: 20px;"> <div style="width: 45%;"> <p>ADDRRSS</p> <p>When the address is 1,2,3.....F, it serves as the subordinate unit 1,2,3.....15.</p> </div> </div>
10	<p>COM (O) 485 communication port (Fault code E2).</p>
11	<p>COM (I) 485 communication port (Fault code E2). COM (O) is interconnected with P, Q and E of COM (I), used for RS-485 communication. 1) If faults occur between the wired controller and the main unit module, all modules will be shut down. 2) If faults occur between the main unit and subordinate units, the subordinate unit module suffering communication fault will be shut down. Less units will be detected by the wired controller, which may display EA, and in the meanwhile, the indicator lamp of the wired controller will flash. Restart 3 minutes later after malfunction be removed.</p>
12	<p>High-pressure protection of the system A and discharge temperature switch protection (Protection code P0). High-pressure protection of the system B and discharge temperature switch protection (Protection code P2). Low-pressure protection of the system A (Protection code P1). Low-pressure protection of the system B (Protection code P3). Constant speed compressor: connection of discharge temperature switch and high-pressure switch of the system in series.</p>
13	<p>Inlet water temperature sensor T62 (TBH2) (Fault code EF).</p>
14	<p>Shell and tube low-temperature ant-freeze sensor T61 (TBH1) (Fault code Eb).</p>

15	Water flow detection (Fault code of the main unit E0) is only valid for the main unit but invalid for subordinate units. 1) Main unit: if abnormal water flow occurs for the first and second time, the main unit board will display fault code E9. If abnormal water flow occurs the third time, the main unit board will display fault code E0 (Off-power recovery is needed), and the wired controller will display fault code E0 (Fault is displayed only after 3 detection). 2) Subordinate unit: (Water flow detection will not be done).
16	Control port (Reserved).
17	Electronic expansion valve of the system B.
18	Electronic expansion valve of the system A. Electronic expansion valve is used to control refrigerant flow under different operating modes and different loads.
19	Auxiliary electric heater. Attention: the control port value of auxiliary electric heater actually detected is ON/OFF but not 220-230V control power supply, so special attention should be paid when installing the auxiliary electric heater. Attention! Under heating mode, when the main unit board detects total water outlet temperature to be lower than 45°C, the switch will be closed, and the auxiliary electric heater will begin to work; when the total water outlet temperature is higher than 50°C, the switch will be opened, and the auxiliary electric heater will stop working.
20	PUMP: Attention: the control port value of the pump actually detected is ON/OFF but not 220-230V control power supply, so special attention should be paid when installing the pump. 1) After receiving start-up instruction, the pump will be started up instantly, and will maintain start-up state always in the process of operation. 2) In case of refrigerating or heating shutdown, the pump will be shut down 2 minutes after all modules stop operating. 3) In case of shutdown under the pump mode, the pump can be directly shut down.
21	Compressor of the system B. Neutral wire. Four-way valve of the system B. Neutral wire.
22	Numerical code tube. 1) In case of stand-by, the address of the module is displayed. 2) In case of normal operation, 10. is displayed (10 is followed by dot). 3) In case of fault or protection, fault code or protection code is displayed.
23	Compressor of the system A. Neutral wire. Four-way valve of the system A. Neutral wire.
24	Outdoor fan A, controlled by T4. Neutral wire.
25	Outdoor fan B, controlled by T4. Neutral wire.
26	(Reserved port)
27	Input of transformer, 220-230V AC current. (Only valid for the main unit).
28	Input of three-phase four-wire power supply (Fault code E1). Three phases A, B and C of power supply should exist simultaneously, and the difference of phase angle should be 120° among them. If the conditions are not met, fault of phase sequence or phase lack may occur, and fault code will be displayed. When the power supply returns to normal condition, fault is removed. Attention: phase lacer and phase dislocation of power supply are detected only in the early period after the power supply is connected, and they are not detected while the unit is in operation.
29	Output of transformer.

1. Faults

When the main unit suffers faults, the main unit stops operating, and all other units also stop running;

When the subordinate unit suffers faults, only the unit stops operating, and other units are not affected.

2. Protection

When the main unit is under protection, only the unit stops operating, and other units keep running;

When the subordinate unit is under protection, only the unit stops operating, and other units are not affected.

14.1.11 250kW Module PCB, outlook view

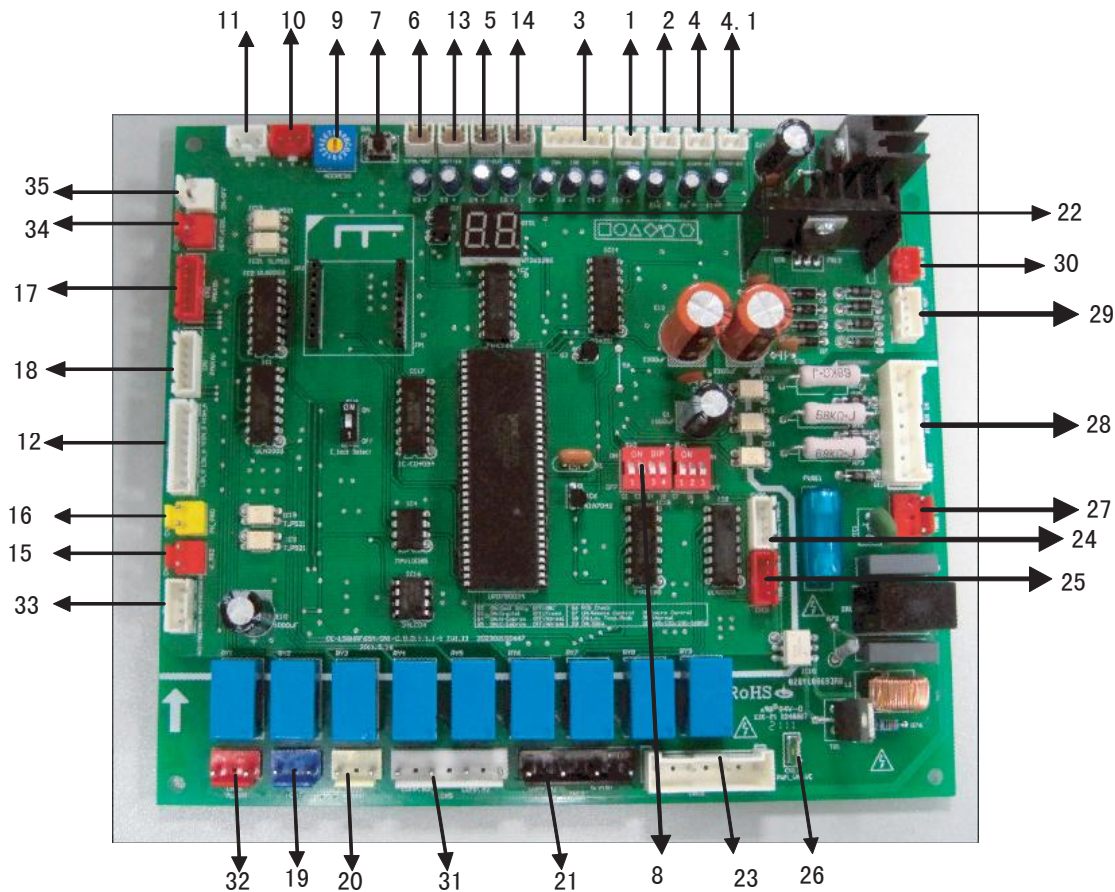

14.1.12 250kW module components description

No	Detail information
1	Detection of current of the compressor A1 (Protection code P4).
2	Detection of current of the compressor A (Protection code P4). Current is not detected within the initial 5 seconds after the compressor is started up. When the current of the compressor is detected to exceed protective value set (33A for constant speed compressor), it will be shut down and re-started after 3 min.
3	T4: outdoor ambient temperature sensor (Fault code E7). T3B: pipe temperature sensor of the condenser B (Fault code E6 and protection code P7). T3A: pipe temperature sensor of the condenser A (Fault code E5 and protection code P6). 1) T4: if there is one system that requires starting outdoor fans, the fans are started through electric control of the unit. Start outdoor fan A only, start A and B gears, and control the unit through T4. 2) T3B and T3A: when the electric control of the modular unit detects the temperature of the outdoor pipe T3A or T3B of the system exceeds the protective temperature 65°C, the corresponding system will be shut down. And it will be re-started up, after the temperature drops below the recovery temperature 60°C. Another system will be not affected. 3) T4, T3B and T3A: when the temperature sensor is detected to suffer open circuit or short circuit, fault alarm will occur. ● When the main unit suffer fault of temperature sensor: the main unit and subordinate units will be shut down. ● When the subordinate unit suffer fault of temperature sensor: the unit will be shut down, but other subordinate units will not be affected.
4	Detection of current of the compressor A2 (Protection code P4).
4.1	Detection of current of the compressor B2 (Protection code P5).
5	Unit outlet water temperature sensor (Fault code E4). Under refrigeration mode and heating mode, conduct adjustment according to the magnitude of unit outlet water temperature. Adjustment range of constant speed capability: ON and OFF.
6	Total outlet water temperature sensor (Fault code E3). Only the main unit is valid, and the subordinate units are invalid. Under refrigerating mode and heating mode, conduct adjustment according to the magnitude of total outlet water temperature. Adjustment range: Load, stabilize, unload, Emergency Stop.

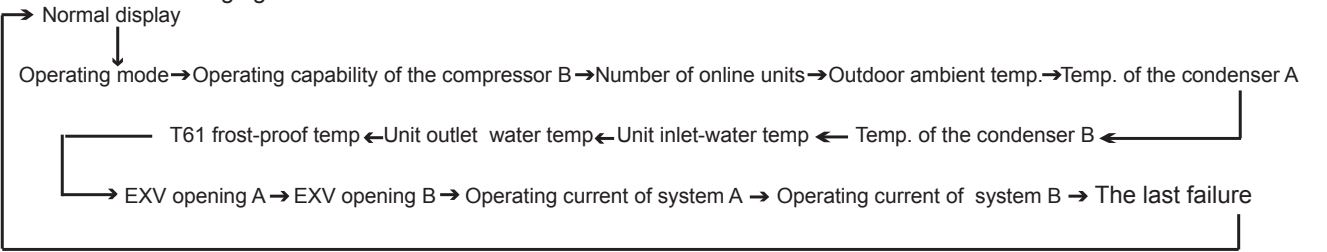
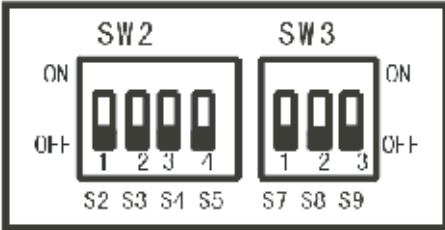
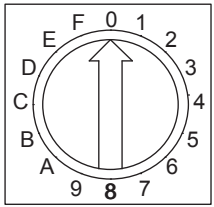
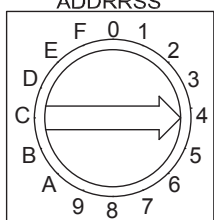
7	<p>Spot check. The operating status of outdoor system can be observed through spot check, and specific display contents are as shown in the following figure:</p>  <ul style="list-style-type: none"> • Display contents of “operating mode”: 1. cooling; 2. heating; 4. pump; 8. Stand-by • Display contents of “number of online units”: the main unit can display the number of online units, and the subordinate unit displays 0.
8	<p>Factory setting</p> 
9	 <p>When the address is 0, it serves as the main unit.</p>  <p>When the address is 1,2,3.....F, it serves as the subordinate unit 1,2,3.....15.</p> <p>Each modular part of modular unit has the same electric control function, and the main unit and subordinate units can be set through address code on the electric control board. The address code 0 # is provided as the main unit. The priority of being the main unit is given to the unit with digital compressor, and other addresses are subordinate units. Only the unit is chosen as the main unit, its electric control can activate such functions as direct communication with the wired controller, refrigerating and heating capability adjustment, pump control, auxiliary electric heater control, total effluent temperature detection and water flow switch detection.</p>
10	COM (O) 485 communication port (Fault code E2).
11	<p>COM (I) 485 communication port (Fault code E2). COM (O) is interconnected with P, Q and E of COM (I), used for RS-485 communication.</p> <ol style="list-style-type: none"> 1) If faults occur between the wired controller and the main unit module, all modules will be shut down. 2) If faults occur between the main unit and subordinate units, the subordinate unit module suffering communication fault will be shut down. Less units will be detected by the wired controller, which may display EA, and in the meanwhile, the indicator lamp of the wired controller will flash. <p>Restart 3 minutes later after malfunction be removed.</p>
12	<p>High-pressure protection of the system A and discharge temperature switch protection (Protection code P0). High-pressure protection of the system B and discharge temperature switch protection (Protection code P2). Low-pressure protection of the system A (Protection code P1). Low-pressure protection of the system B (Protection code P3). Constant speed compressor: connection of discharge temperature switch and high-pressure switch of the system in series.</p>
13	Inlet water temperature sensor (Fault code EF).
14	Shell and tube low-temperature ant-freezing sensor (Fault code Eb).
15	<p>Water flow detection (Fault code of the main unit E9) is only valid for the main unit but invalid for subordinate units.</p> <ol style="list-style-type: none"> 1) Main unit: if abnormal water flow occurs, the main unit board and the wired controller will display fault code E9. 2) Subordinate unit: (Water flow detection will not be done).
16	Power phase detection (Fault code E8).
17	Electronic expansion valve of the system B.
18	<p>Electronic expansion valve of the system A. Electronic expansion valve is used to control refrigerant flow under different operating modes and different loads.</p>
19	<p>Auxiliary electric heater. Attention: the control port value of auxiliary electric heater actually detected is ON/OFF but not 220-230V control power supply, so special attention should be paid when installing the auxiliary electric heater. Attention!</p>

	Under heating mode, when the main unit board detects total water outlet temperature to be lower than 45°C, the switch will be closed, and the auxiliary electric heater will begin to work; when the total water outlet temperature is higher than 50°C, the switch will be opened, and the auxiliary electric heater will stop working.
20	PUMP: Attention: the control port value of the pump actually detected is ON/OFF but not 220-230V control power supply, so special attention should be paid when installing the pump. 1) After receiving start-up instruction, the pump will be started up instantly, and will maintain start-up state always in the process of operation. 2) In case of refrigerating or heating shutdown, the pump will be shut down 2 minutes after all modules stop operating. 3) In case of shutdown under the pump mode, the pump can be directly shut down.
21	One compressor of the system B(B1). Neutral wire. Four-way valve of the system B. Neutral wire.
22	Numerical code tube. 1) In case of stand-by, the address of the module is displayed. 2) In case of normal operation, 10. is displayed (10 is followed by dot). 3) In case of fault or protection, fault code or protection code is displayed.
23	One compressor of the system A(A1). Neutral wire. Four-way valve of the system A. Neutral wire.
24	Outdoor fan A, controlled by T4.
25	Outdoor fan B, controlled by T4.
26	PWM pressure relieve valve control(For digital compressor).
27	Input of transformer, 220-230V AC current. (Only valid for the main unit).
28	Input of three-phase four-wire power supply (Fault code E1). Three phases A, B and C of power supply should exist simultaneously, and the difference of phase angle should be 120° among them. If the conditions are not met, fault of phase sequence or phase lack may occur, and fault code will be displayed. When the power supply returns to normal condition, fault is removed. Attention: phase lase and phase dislocation of power supply are detected only in the early period after the power supply is connected, and they are not detected while the unit is in operation.
29	Output of transformer.
30	Power port for the current board.
31	One compressor of the system B(B2). Neutral wire. One compressor of the system A(A2). Neutral wire.
32	The alarm signal output of the unit(ON/OFF signal).
33	Anti-freezing pressure protection of the system A(Protection code Pc). Anti-freezing pressure protection of the system B(Protection code Pd).
34	Remote control port(ON/OFF signal, effect on NO.0 unit). 1. Dial the code S7 in the main control board to the "ON" position and enter to the remote control mode (The wired controller is invalid). 2. If the port is closed, the unit is turned on, else, the unit is turned off.
35	Remote mode control port(ON/OFF signal, effect on NO.0 unit) 1. Dial the code S7 in the main control board to the "ON" position and enter to the remote control mode (The wired controller is invalid). 2. First, the ON/OFF port is closed, the second, if this port is closed, the unit enters the heating mode, else, the unit enters cooling mode.

1. Faults

When the main unit suffers faults, the main unit stops operating, and all other units also stop running;

When the subordinate unit suffers faults, only the unit stops operating, and other units are not affected.

2. Protection

When the main unit is under protection, only the unit stops operating, and other units keep running;

When the subordinate unit is under protection, only the unit stops operating, and other units are not affected.

14.3 KJR-120A/MBE (Standard accessory)

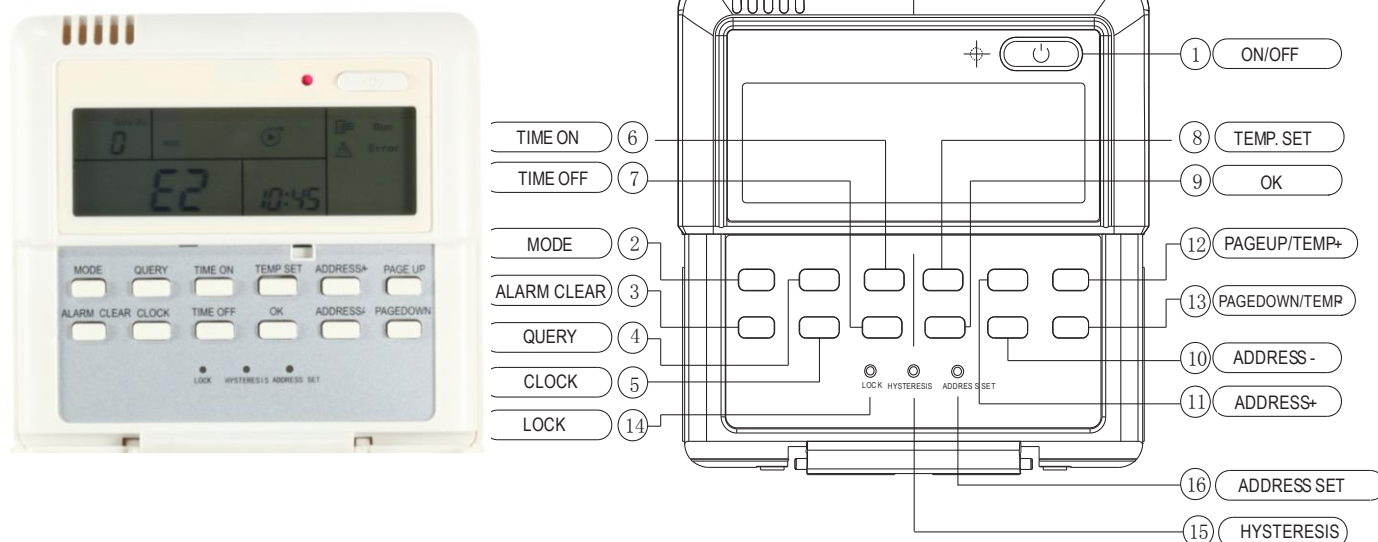

1. Operating instructions of buttons

① ON/OFF button:

In the power off status, press this key and the startup indicator led comes on, and the wired controller enters the startup status and keeps the current set information such as temperature value, timing. In the startup status, press this button once, and the startup indicator led goes off and transmits the shutdown information.

② Operation mode button:

In the power off status, press this button to select the operation mode. This function is invalid at power on status.

Modes shifted sequence as follows:

a. Mode of KJR-120A/MBE air cooled modular wired controller:



b. Cooling only air cooled modular wired controller:

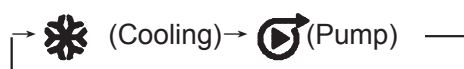

③ ALARM CLEAR button

Press the button, then can clear some errors which need to operate manually for recovery. These errors represent there are problems while the unit is operating, but will not affect the system safety. If this type of error came out frequently then it needs to check and maintain the unit.

④ QUERY button

Press the button, to inquire state information of No. 0 to No. 15 outdoor units (the default is state information of No.0 unit) and enter inquiry state. After entering inquiry state, inquire the information of the former unit or the following unit through “ADDRESS/+” and “ADDRESS/-”. After a certain outdoor unit is selected, state information of the outdoor unit can be inquired through “page up” and “page down”. The inquiry sequence is “Error→protection →outlet water temperature T_{ou} →inlet water temperature T_{in} →outdoor ambient temperatures T_4 →outdoor pipe temperature T_{3A} →outdoor pipe temperature T_{3b} →current of the compressor I_A → current of the compressor I_b →anti-freezing temperature T_6 →electronic expansion valve opening F_A →electronic expansion valve opening F_b →Error.....The wired controller only displays the last fault information and the protection information, when query is conducted on fault and protection information.

⑤ CLOCK button

Press the “CLOCK” button once 【Press for the first time】, and enter to the hour adjustment, and press again 【Press for the second time】, and enter to the minute adjustment. The numerical value of hour and

minute can be adjusted by “ADDRESS/+” and “ADDRESS/-”, after the adjustment then press the OK button for the setting confirmation.

⑥⑦ TIME ON/TIME OFF button

Press the “TIME ON” button once 【Press for the first time】, and enter to the hour adjustment of timing on, and press again 【Press for the second time】, and enter to the minute adjustment of timing on. The numerical value of hour and minute can be adjusted by “ADDRESS/+” and “ADDRESS/-”, after the adjustment then press the OK button for the setting confirmation. Enter to the timing setting status, if do not adjust for 8s, then it will be confirmed the current setting and exit the timing setting status.

Press the “TIME OFF” button, and set the timing off time as the above method.

⑧ TEMP SET button

Setup the total water outlet temperature in cooling and heating mode.

The numerical value of temperature setting can be adjusted by “ADDRESS/+” and “ADDRESS/-”.

⑨ OK button

Once finished upon, press OK key, wired controller will delivery order to main unit.

⑩ ADDRESS/+ button

Press this button at Check mode; when select the next modular, the operation status of the next modular will display; if the current modular is 15#, and the next one is 0#.

Press this button for add address at wire address setting mode. If the wired controller address is 15, press this key will display the next address is 0.

Press this button for add temperature at wire temperature setting mode.

Press this button for add clock or time at wire clock or time setting mode.

⑪ ADDRESS/- button

Press this button at query mode; when select the previous modular, the operation status of the previous modular will display; if the current modular is 0#, and the previous one is 15#.

Press this button for minus address at wire address setting mode. If the wired controller address is 0, press this key will display the next address is 15.

Press this button for minus temperature at wire temperature setting mode. Press this button for minus clock or time at wire clock or time setting mode.

⑫ & ⑬ PAGEUP/DOWN button to spot check the operation parameters of unit in the main menu.

⑭ HYSTERESIS button (Hidden)

Use a small round bar with 1mm diameter to press this button, then can adjust the return parameter $\delta = (2,3,4,5^{\circ}\text{C})$. The numerical value of hysteresis can be adjusted by “ADDRESS/+” and “ADDRESS/-”, after the adjustment then press the OK button for the setting confirmation.

The factory defaults $\delta = 2^{\circ}\text{C}$.

⑮ LOCK button (Hidden)

Use a 1mm-diameter round bar to lock the current setting. Press this button again to unlock.

⑯ ADDRESS SET button (Hidden)

The address of wired controller be set by press this button. The address range 0~15, therefore, 16 wired controller could be parallel at most.

When there is only one wired controller, it is necessary to execute this setting, the address of wired controller should be set to '0'(main wired controller).

LCD Diagram of Wired Controller

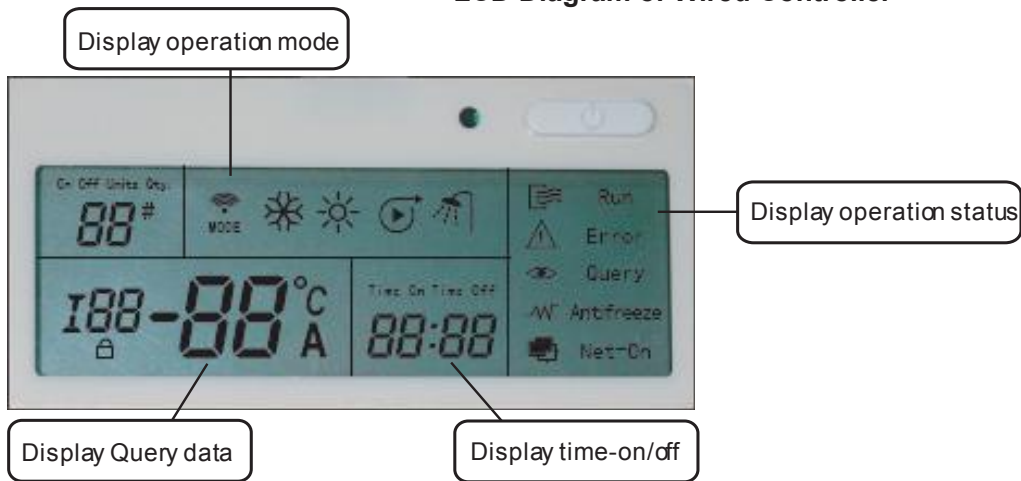

2. OPERATION PROCEDURE OF WIRED CONTROLLER

● Operation procedure of mode setting

- 1). Press MODE at shutdown status, you could select appropriate mode as you want. The function is invalid at startup status.
- 2). The modes which you can select depend on outdoor unit.

● Operation procedure of water temperature setting

- 1). Press [TEMP SET] button of wired controller when background light is on.
- 2). Press [ADDRESS/+] or [ADDRESS/-] button select your require water temperature. Temperature range is not same in different operation mode.
- 3). Temperature range depend on outdoor unit .

● Operation procedure of system ON/OFF

Press [ON/OFF] button, running indicator of wired controller is light, unit is start to run, and display running status at wired controller. Press this button once again, unit will stop running.

Operation procedure of TIME ON/TIME OFF

Press [TIME ON] button adjust user's require time by [ADDRESS/+] or [ADDRESS/-] (minute and hour could be shifted by this button.....).

Use the same method to set Time off.

(Note: Time ON/OFF is reality time.)

In the power off status, you can only set TIME ON first time, afterwards you can set TIME OFF.

In the power on status, you can only set TIME OFF first time, afterwards you can set TIME ON.

For example: the system is In the power off status at present, and it is 10:00 now, TIME ON setting is 12:00, TIME OFF setting is 11:00, then the system will turn on at 12:00 today, and turn off at 11:00 next day.

● Operation procedure of disable the function of Time ON/Time OFF.

Long press [TIME ON] button, you could cancel this function. Long press [TIME OFF] button, you could cancel this function.

When you turn on or turn off the system by pressing ON/OFF button, it will cancel the function of time on/off.

● Operation procedure of system information querying

- 1). Press [QUERY] entering Check status.
- 2). Press [ADDRESS/+] or [ADDRESS/-] button, select the unit you want to query.
- 3). Press [PAGEUP] or [PAGEDOWN] button to query the unit information, which includes E-, P-, Tou, Tin, T4, T3A, T3b, IA, Ib, T6, FA, Fb, etc.

● Operation procedure of HYSTERESIS TEMP.SET(δ)

- 1). Through the hysteresis setting, the system can adjust the load effectively.
- 2). The adjusting logic of cooling mode : (the parameter of $\delta_1, \delta_2, T_{j1}$ and T_{j2} are decided by the outdoor unit)

Unit start temperautre	$T_{AL} \geq T_s + \delta_1$
Loading region	$T_{AL} > T_s + \delta$
Stable region	$T_s < T_{AL} \leq T_s + \delta$
Unloading region	$T_{j1} < T_{AL} \leq T_s$
Abrupt stop region	$T_{AL} \leq T_{j1}$

- 3). The adjusting logic of heating mode: (the parameter of $\delta_1, \delta_2, T_{j1}$ and T_{j2} are decided by the outdoor unit)

Unit start temperautre	$T_{AL} \leq T_s - \delta_2$
Loading region	$T_{AL} < T_s + 1 - \delta$
Stable region	$T_s - 1 + \delta > T_{AL} \geq T_s + 1 - \delta$
Unloading region	$T_s - 1 + \delta \leq T_{AL} < T_{j2}$
Abrupt stop region	$T_{AL} \geq T_{j2}$

(TAL: total outlet water temperature)

● Fault alarm handling

- 1) When unit fails or the wired controller detects failure of communication with the outdoor units, the indicator blinks. After all faults of the system and the wired controller are eliminated, the indicator stops blinking. The fault indicator and the operation indicator share the same LCD.
- 2) Some errors will be auto cleared after the errors are cleared, and some error must press the "ALARM CLEAR" button and then be cleared after the errors are cleared. The details can refer to the error code table. If this type error comes out frequently, then need to check and maintain the unit.



NOTE

- 1). Before power failure of the heating water system or wired controller, the wired controller memorizes the status of the unit automatically, and sets the water temperature value except timing on/off function. After being powered on, the wired controller will send the relevant signals to the heating water system according to memorized status before power failure, in order to ensure that the unit can run in the originally set status after restoration of the power supply.
- 2). In the normal status, the background light is off. Press any key can only turn on the background light.
- 3). In order to protect the equipment, it is not allowed to change the running mode quickly or frequently. It should operate the wired controller to start up the unit after 3 minutes later or all units are shutdown.
- 4). The wired controller and the outdoor unit must connect with the same power supply, powered up and powered off simultaneously. It is not allowed to cut off the power supply separately.
- 5). When several wired controllers are parallel connected, the timing message can't communicating in these wired controllers, and the timing will work separately. In order not to confuse, we suggest set the timing message on one wired controller for the reason of indoor unit performance is compliance with the sequence of setting time.
- 6). During changing or installing the battery, pay attention to the "+", "-" poles of the battery and install it correctly, or will damage the control panel or battery, even worse will put lives at risk.

3. Display

Ordinary displayed data

- a. Ordinary displayed data are displayed in all display pages.
- b. If the unit system is under running state, i.e. one or more than one modular unit is under running operation, there will be a dynamic display of . If the system is under OFF state, there is no display.
- c. If the communication with the main unit modular unit is fail, it displays E2.

d. If it is under the host computer network control, Net-ON displays, otherwise there is no display.

e. If it is under wired controller locked or button locked state, it displays  the lock mark. There will be no display after the lock is unlocked.

Treatment of display data

The data display area is divided into Up area and Down area, with two groups of two-digit half 7-segment digital display, respectively.

a. Temperature display

Temperature display is used for displaying the total outlet water temperature of unit system, outlet water temperature, condenser pipe temperature T3A of system A, condenser pipe temperature T3B of system B, outdoor environmental temperature T4, anti-freezing temperature T6 and setting temperature Ts, with allowable data display scope $-15^{\circ}\text{C}\sim 70^{\circ}\text{C}$. If the temperature is higher than 70°C , it is displayed as 70°C . If there is no effective date, it displays “— —” and indication point $^{\circ}\text{C}$ is on.

b. Current display

Current display is used for displaying modular unit system A compressor current IA or system B compressor current IB, with allowable display scope 0A~99A. If it is higher than 99A, it is displayed as 99A. If there is no effective date, it displays “— —” and indication point A is on.

c. Failure display

It is used for displaying the total failure warning date of unit or that of modular unit, with failure display scope E0~EF, E indicating failure, 0~F indicating failure code. “E-“ is displayed when there is no failure and indication point # is on at the same time.

d. Protection display

It is used for displaying the total system protection data of unit or the system protection data of modular unit, with protection display scope P0~PF, P indicating system protection, 0~F indicating protection code. “P-“ is displayed when there is no failure.

e. Unit number display

It is used for displaying the address number of the currently selected modular unit, with display scope 0~15 and indication point # is on at the same time.

f. Display of online unit number and startup unit number

They are used for displaying the total online modular units of the whole unit system and the number of the modular unit under running state, respectively, with display scope 0~16.

Any time when the spot check page is entered to display or change modular unit, it is needed to wait for the up-to-date data of the modular unit received and selected by wired controller. Before receiving the data, the wired controller only displays “——” on the data display Down area, and the Up area displays the address number of the modular unit. No page can be turned, which continues until the wired controller receives the communication data of this modular unit.

Main page display

Main page display consists of several pages and the total number of pages is not fixed.

a. The default display is the first page; other pages are displayed by pressing page-up/down button circularly.

b. The first page of data display Down area displays the total outlet water temperature, and then the total outlet water temperature and the outlet water temperature are displayed according to the page number circularly and in turn.

c. The first page of data display Up area displays the number of online units, and the second page displays the number of startup running units

d. When all the pages of the main page data are displayed, continue to press page-down button to display the first page, and press page-up from the first page to display the last page.

Query display

Query page data consist of several pages and the total number of pages is not fixed.

- a. Upon entering the spot check page display for the first time, the default selected 0# modular unit displays the state data of the first page.
- b. Contents in other pages are displayed circularly by pressing the page-up/down button.
- c. Pages 1-12 of data display Down area show Error code, protection code, outlet water temperature T_{ou} , inlet water temperature T_{in} , outdoor ambient temperatures T_4 , outdoor pipe temperature T_{3A} , outdoor pipe temperature T_{3b} , current of the compressor I_A , current of the compressor I_b , anti-freezing temperature T_6 , electronic expansion valve opening F_A , electronic expansion valve opening F_b
- d. The first page of data display Up area displays the unit number.
- e. Starting from the first page, the data display Down area displays the failure code of the current modular unit. One failure code may be displayed at most by turning page. In case of exceeding one failure, the following ones will not be displayed. If there is no failure, only one page of failure code displays "E-" and the next page begins to display protection code.
- f. After all the failure codes of the data display Down are displayed, protection code is displayed. One protection code at most may be displayed by turning page. In case of exceeding one protection code, the following ones will not be displayed. If there is no protection, only one page of protection code displays "P-", and the next page begins to display the contents of the first page.
- g. After all the pages of spot check data are displayed, continue to press page-down button to display the first page, and press page-up from the first page to display the last page.
- h. Select the modular unit address number of spot check by pressing "address decrease" or "address increase" button to inquire the running state data of different modular units.

Any time when the spot check page is entered to display or change modular unit, it is needed to wait for the up-to-date data of the modular unit received and selected by wired controller. Before receiving the data, the wired controller only displays "—" on the data display Up area, and the down area displays the address number of the modular unit. No page can be turned, which continues until the wired controller receives the communication data of this modular unit.

4. INSTALLATION PROCEDURE

Installation procedure:

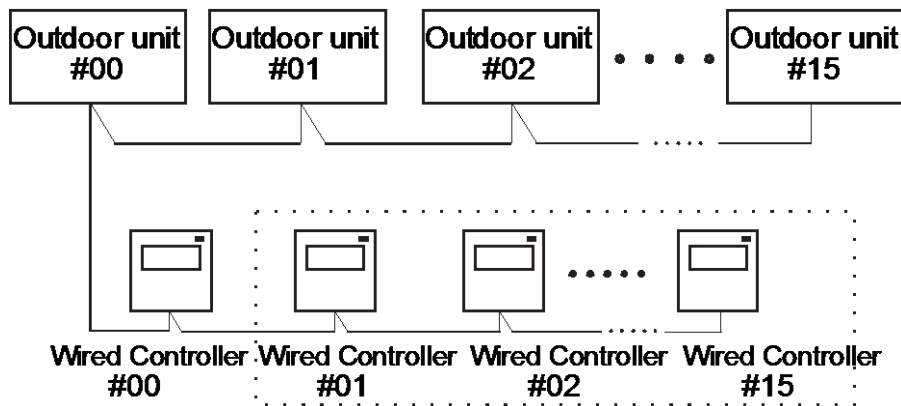

Use PQE connect with each other when several wired-controllers are parallel.



NOTE

Please connect the attached shorted-wires to the corresponding communication port COM(I) or COM(O) in the main control board of the last parallel unit (dial code). Directly connect to the last parallel unit if only one unit is connected.

The wiring procedure and principles are shown in the figure:

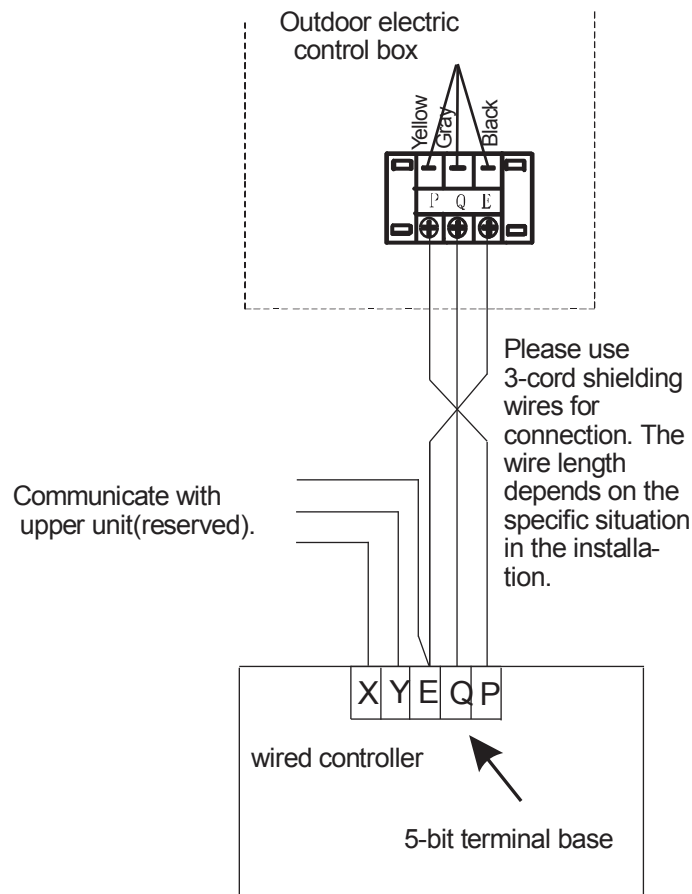

5. OVERVIEW OF WIRED CONTROLLER

Basic conditions of operating the wired controller

- 1). Applicable range of supply voltage: Input voltage is AC 220V±10%, powered to wired controller by attached power adapter.
- 2). Operating environment temperature of wired controller: -15℃~+46℃.
- 3). Operating RH of wired controller: RH40%~RH90%.

OUTLINE OF FUNCTIONS

This wired controller provides the following functions:

- 1). Connect with the outdoor unit through the terminals P, Q and E. Connect with the upper unit through the terminals X, Y and E(reserved). Connect with other wired controllers through the terminals P, Q and E.
- 2). Set the action mode through the keypad operation.
- 3). Provide the LCD display function.
- 4). Provide the timing startup function.
- 5). Real-time clock function (the wired controller inner place 3V battery)

When the wired controller is powered on, the LCD will display the current time; if it is powered off, the clock will not be displayed, then it will be auto-updated when the wired controller is re-power on.

6. ON/OFF

Follow the following diagram for system ON/OFF

Turn on the unit

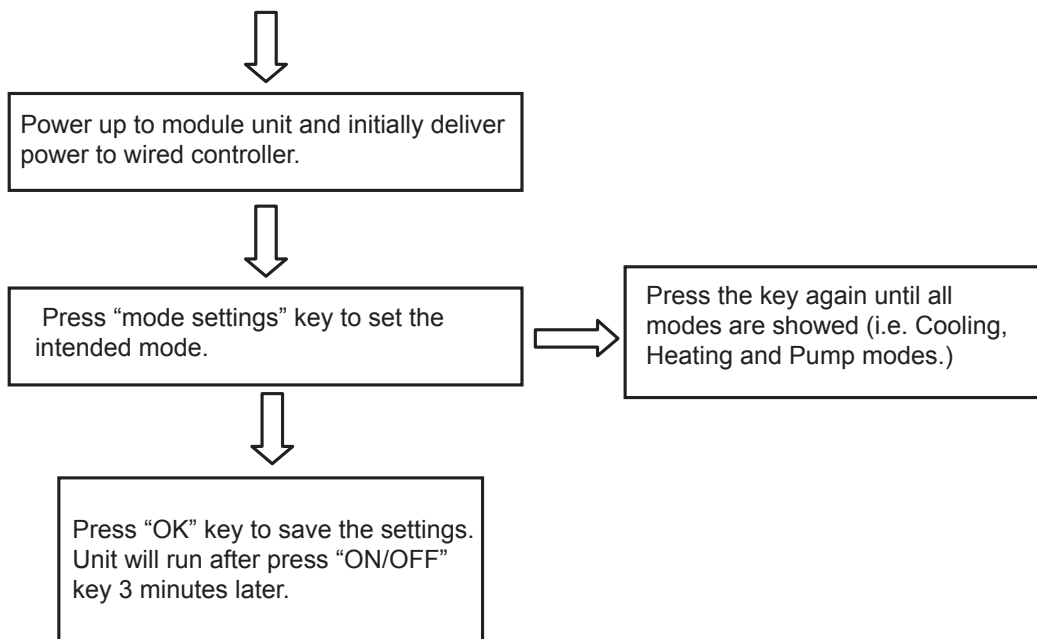

Turn off the unit

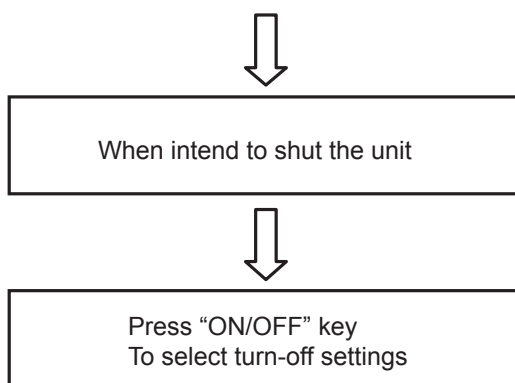

14.5 Control software

a. Interface introduction

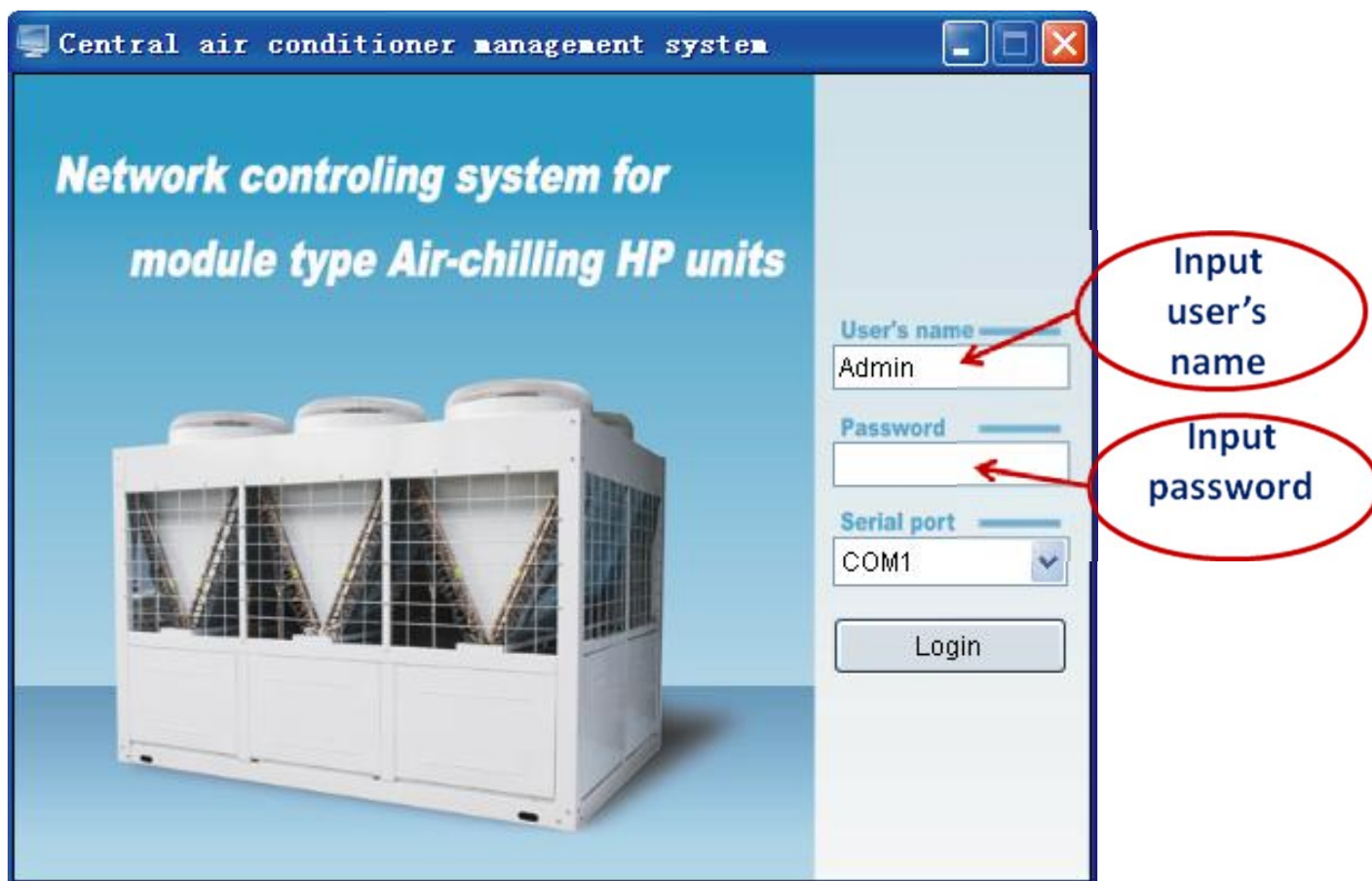

1) The LOGIN window as above picture.

2) User need to input the name and password (default name: Admin, default password: Admin); user's name and password could be changed after login.

3) Select the computer serial port. The system default selection is COM1 (the software will checkout the available serial ports in the computer automatically, and will list them at the Optional Table).

4) When login on, you must insert the Softdog provided by manufacturer to the computer, otherwise, cannot be login the system and the window as Fig.4-1 ,and the Softdog Error would show as follows.

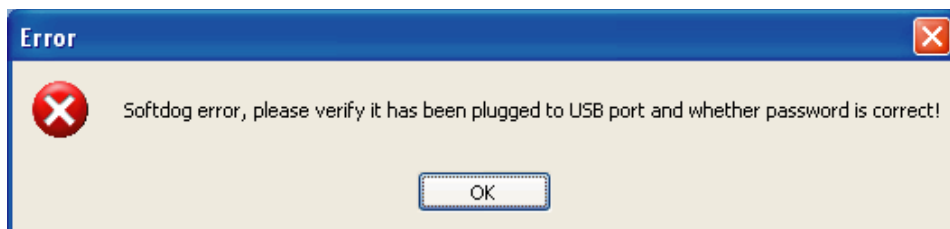

Fig.4-1

5) Be sure the softdog has been inserted to USB port all the time while the software is running, otherwise the softdog error dialogs displays as Fig.4-2.



Fig.4-2

6) When provide a wrong USER'S NAME, the window as Fig.4-3 will be display, while PASSWORD error, the window shows as Fig.4-4.



Fig.4-3

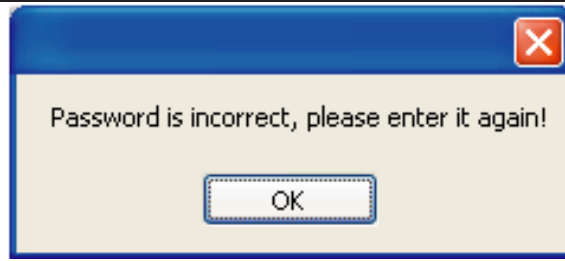

Fig.4-4

7) In case the password error time exceed 6 times (i.e. the 7th times password error), the window show as Fig.4-5, and then click OK, it will exit the program.

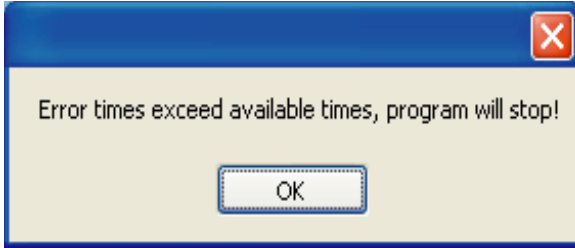

Fig.4-5

8) In case the selected serial port is unavailable, the window as Fig.4-6 will be display.

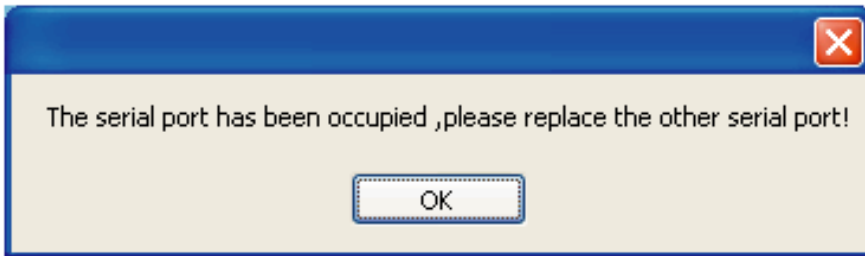

Fig.4-6

b. Detail application manual

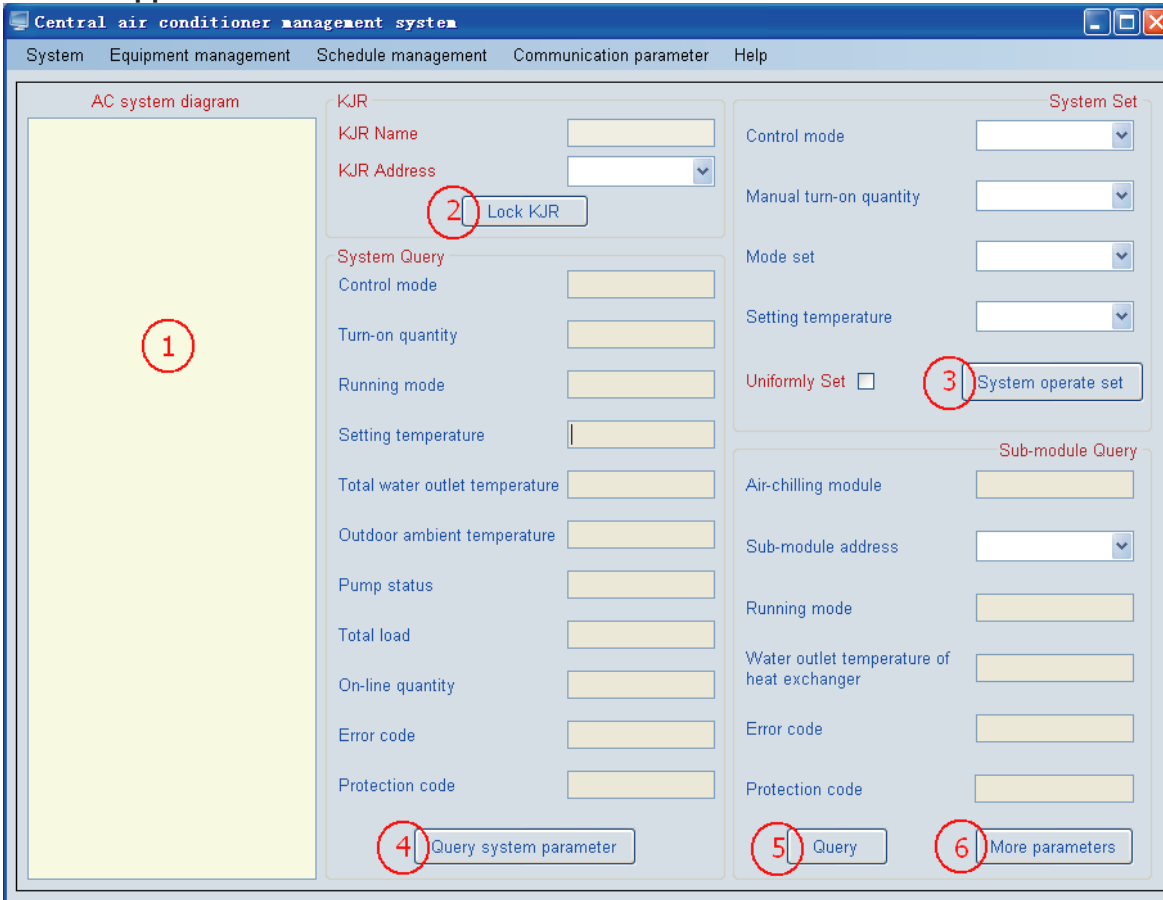
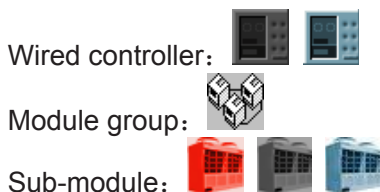

Fig.4-7

Main interface of this software as Fig.4-7, detail as follows:

1) Menu includes: “System”、“Equipment management”、“Schedule management”、“Communication parameter”、“Help”。

2) System configuration illustration (The ① as Fig.4-7): Not more than 16 wired controllers could be connected to the computer. This kind of wired controller could be connected to the module group of : 30KW、65KW、185KW etc. Total 16 sub-modules could be jointed to a wired controller. (For the Maximum sub-module quantity could be jointed to a wired controller, the quantity conversion between module group and sub-module, please refer to “Software application” .



For the meaning of the different color represent, please see below picture. AC system diagram in Software Application”









No.	Color	Status	Equipmrt
1		OFF-LINE	CONTROLLER()、SUB-MODULE()
2		NORMAL	CONTROLLER()、SUB-MODULE()
3		ON-LINE ERROR	SUB-MODULE()

Fig.4-8

3) "Lock KJR" (The ② in Fig.4-7): To lock or unlock the current selected wired controller to limit the wired controller setting the refrigeration system.

4) "System operate set" (The ③ in Fig.4-7): To set the operation of the selected refrigeration system.

5) "Query system parameter" (The ④ in Fig.4-7), Press this key to query the selected refrigeration system, the current operating parameter will be display.

6) "Query" (The ⑤ in Fig.4-7): Press this key to query the selected sub-module, the current operating parameter will be display.

7) "More parameters" (The ⑥ in Fig.4-7): More operating parameter will be display.

If the software has been configured, then will automatic scan the configured system while open the software, the scan interface display as Fig.4-9.

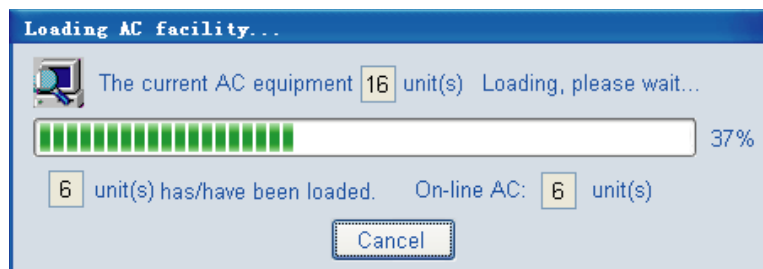

Fig.4-9

Provided that malfunction occur, window as Fig.4-10.

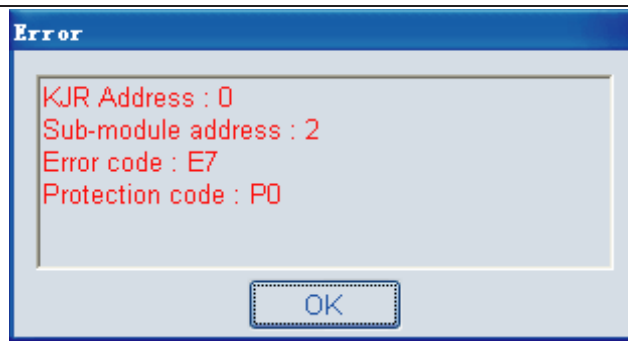

Fig.4-10

c. Menu application

1) “System” includes: “Password Modification”, “Re-login”, “Exit the program”.

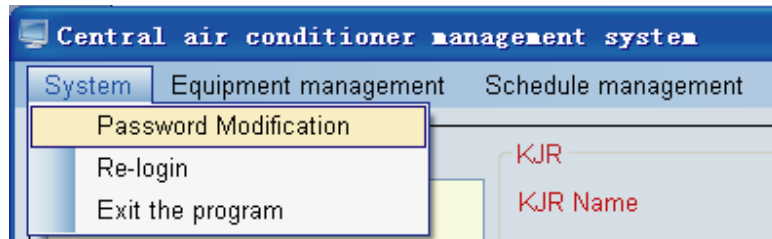

Fig.4-11

①Click “Password Modification” will display window as Fig.4-12 input old password as requirement, and then reset a new password, click “OK” or “Modify”, window as Fig.4-13t will show that new password has been already successful set;

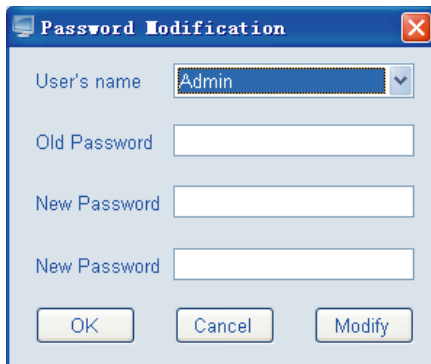
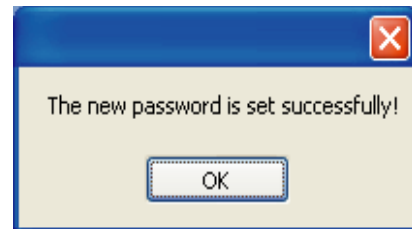

Fig.4-12

Fig.4-13



If input an old password error, window as Fig.4-14 will show; if the new passwords be input do not match, the message box as Fig.4-15 will display.

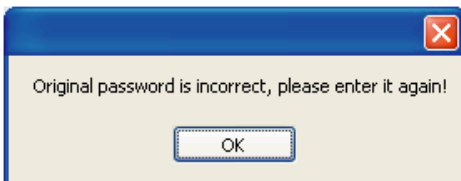

Fig.4-14

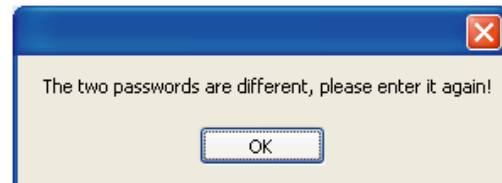

Fig.4-15

②Click “Re-login”, window as Fig. 4-16 will display that interface ask user whether re-login the system, if yes, please click “OK Click “Re-login”, system will close the main interface and enter to the login interface again.

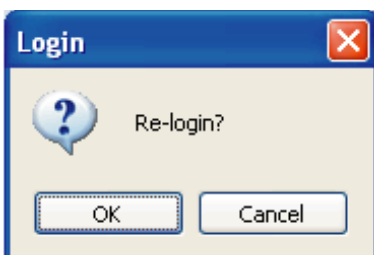

Fig.4-16

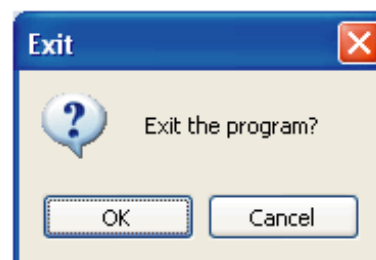

Fig.4-17

③Click “Exit the program” to quit the program, while click “Cancel”, system will not quit, as Fig. 4-17.

2) “Equipment management” includes: “KJR Setting”, “Module parameter setting”, “Outdoor module setting”, as Fig. 4-17.

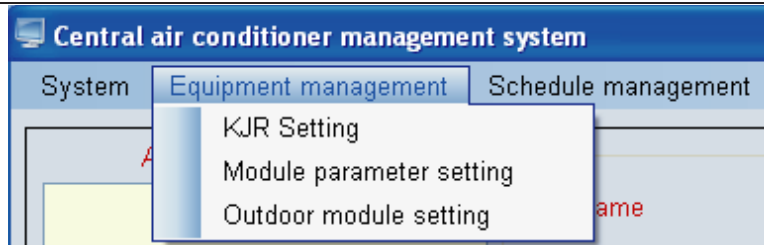

Fig.4-18

①. Click “KJR Setting”, the window as Fig. 4-20 will be display——add wired controller to the system to be monitored.

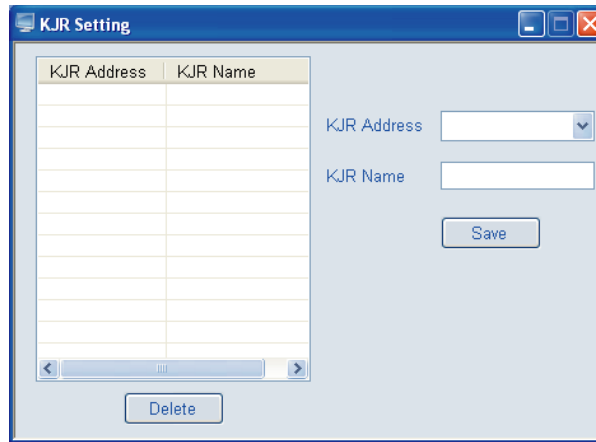

Fig.4-20

Detail operation procedure as follows:

- a、 Add a wired controller: Select the wired controller address (0-15) at the “KJR Address” , fill the wired controller name at “KJR Name” and click “Save” .
- b、 Modify wired controller: Select an existing wired controller (by click the drop down list of the KJR Address at the left Chart or by click the drop down list of the KJR Address at the right), and re-fill the wired controller name and click “Save” to finish the wired controller modification(see Fig. 4-21). KJR Name could not empty or pure blank character string (pure blank charter string is composed by space and tab)

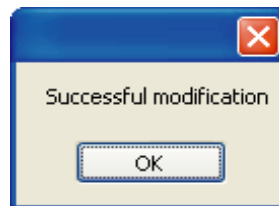

Fig.4-21

- c、 Delete wired controller: Select an existing wired controller (as above method), and click “Delete” , if there is no outdoor module controlled by any wired controller (see Fig. 4-22), the one could be deleted; if there are outdoor modules controlled by wired controller (see Fig. 4-23), a failed delete message box would pop up (see Fig. 4-24). As long as delete all modules under connect the wired controller, the wired controller could be deleted.

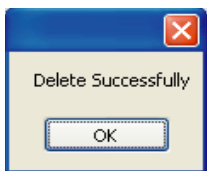

Fig.4-22

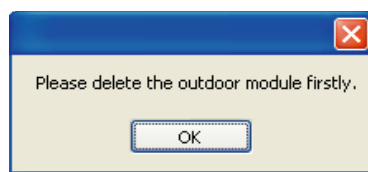

Fig.4-23

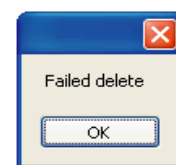

Fig.4-24

Note: Please select wired controller according to actual system condition.

② Click the “Module parameter setting”, a window as Fig.4-25 will pop up: add module group under connect with the wired controller

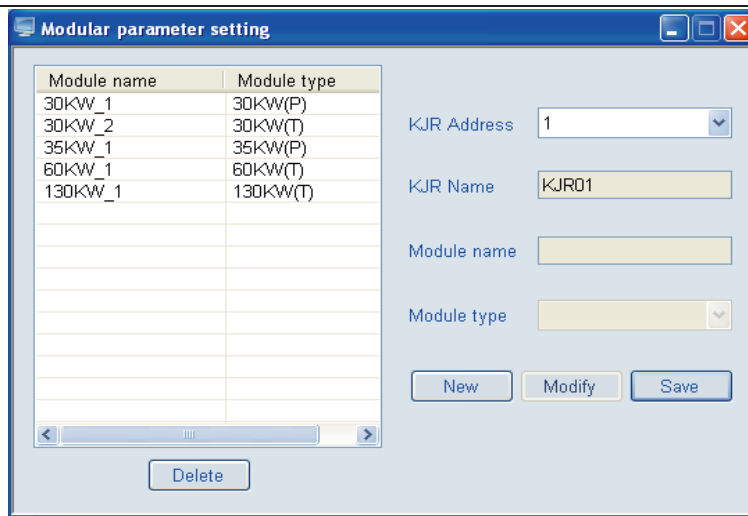

Fig.4-25

a、 Add sub-module: Select the existing wired controller address from the “KJR Address” , and select the configured module group at the drop-down box of “Module name” , select the sub-module address in the drop-down box of the configured “Sub-module address” , and then click “Add”. The sub-module would not be configured, if the sub-module address without configured in this wired controller; if sub-module is exists, a message box would pop up as Fig. 4-26 to note you, the sub-module cannot be configured. If the sub-module quantity exceeds than the maximum module under connect with wired controller, the message box as Fig. 4-27 will pop up.

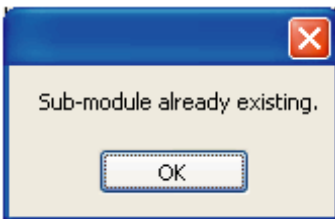

Fig.4-26

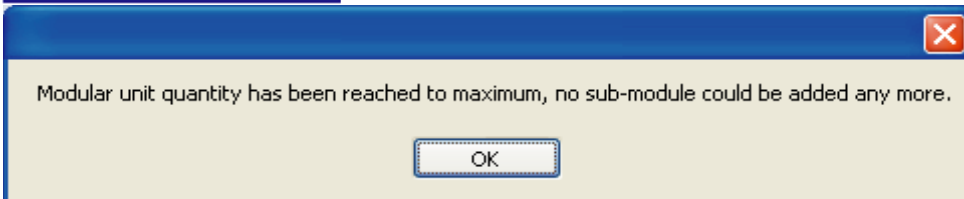

Fig.4-27

b、 Delete sub-module: Select the sub-module which wanted to delete (select the wanted delete sub-module at the drop-down box of “Sub-module address”), and click “Delete” to finish this operation.

3) “Schedule management” includes: “Weekly timing setting” and “Error record”. See Fig. 4-28

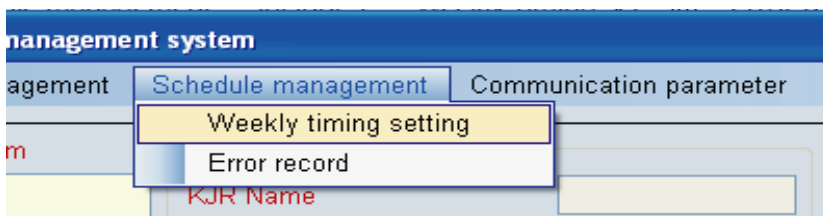

Fig.4-28

①Click “Weekly timing set” a window as Fig. 4-29 would pop up——finish the weekly schedule management setting, each wired controller represents a refrigeration system; and the existing wired controller is a wired controller has already been configured in the system.

Wired controller icons: 

(1) Gray color represents Weekly Timing without set in this wired controller.

(2) Light green represents at less one Weekly Timing schedule has been set in this wired controller, without schedule in activating.

(3) Blue color represents at less one Weekly Timing schedule has been set in this wired controller as well as at less one of this schedule in activating.

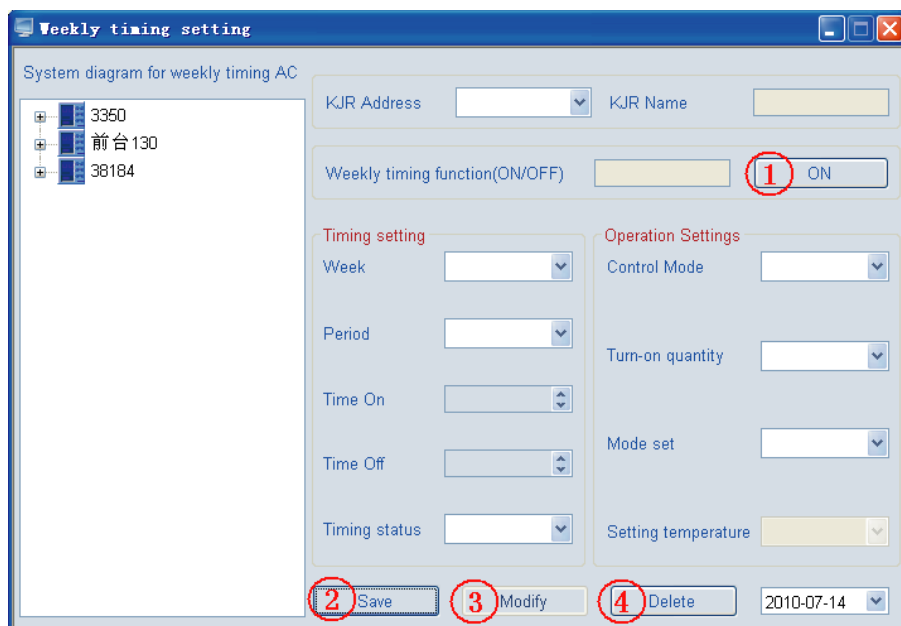

Fig.4-29

- a. KJR Address——Wired controller address, each wired controller represents one refrigeration system.
- b. Weekly timing function——Display the weekly set status in the current wired controller is ON or OFF (ON or OFF could display as long as at least one weekly schedule has been set, otherwise, nothing would display.)
- c. Detail weekly timing parameter—— Week, Period, Time On, Time Off, Timing Status, Control Mode, Turn-on quantity, Mode set and Setting temp..
- d. Timing ON/OFF key for controlling the weekly timing wired controller (See the ① key in the figure) —— when Weekly Timing Function is ON, the key shows OFF (see Fig. 4-30), once click the key, all weekly timing function would be turned off, and then the Weekly Timing Function displays OFF, while the key shows ON (see Fig. 4-31); when Weekly Timing Function is OFF, the key shows ON (see Fig. 4-38), once click the key, all weekly timing function would be turned on, and then the Weekly Timing Function displays ON, while the key shows OFF (see Fig. 4-32)

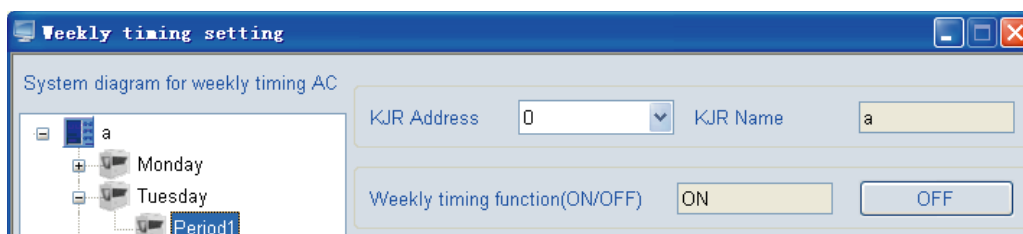

Fig.4-30

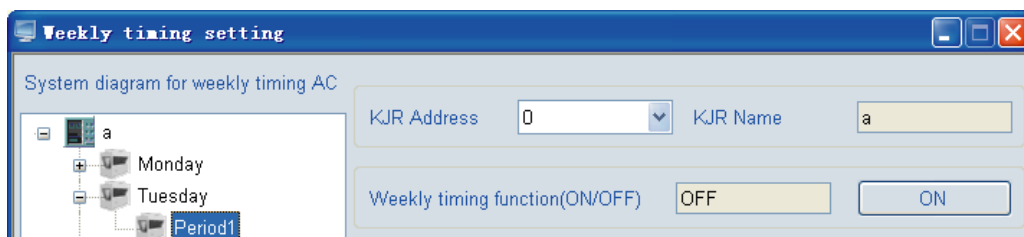

Fig.4-31

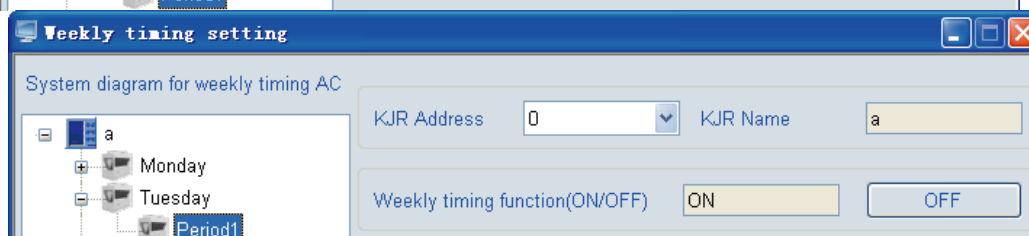

Fig.4-32

- e. Save (See the ② key in the Fig.4-29) —— Save the current settings or the modified settings.

f. Modify(See the ③ key in the Fig.4-29) — Press this key the parameter of selected period become changeable, and then click “Save” . Press the key again, all parameters in this period become unchangeable. See Fig. 4-33.

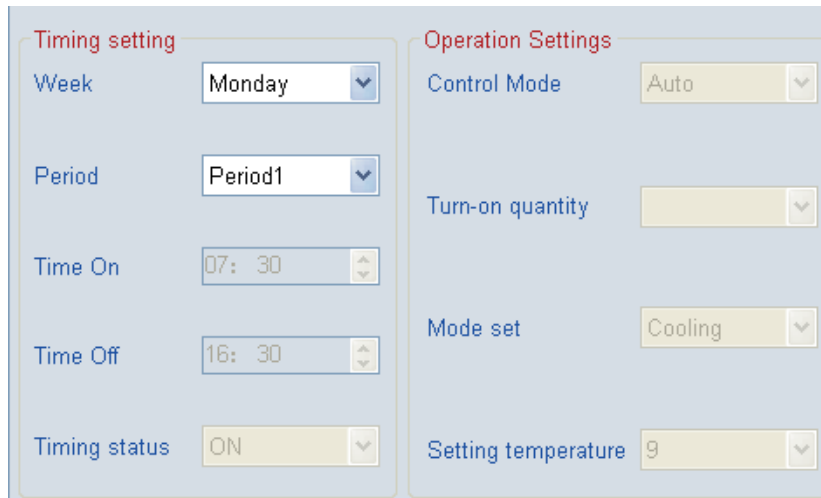

Fig.4-33

Select the setting Period, click “Modify”, all parameter will become changeable status, see Fig. 4-34.

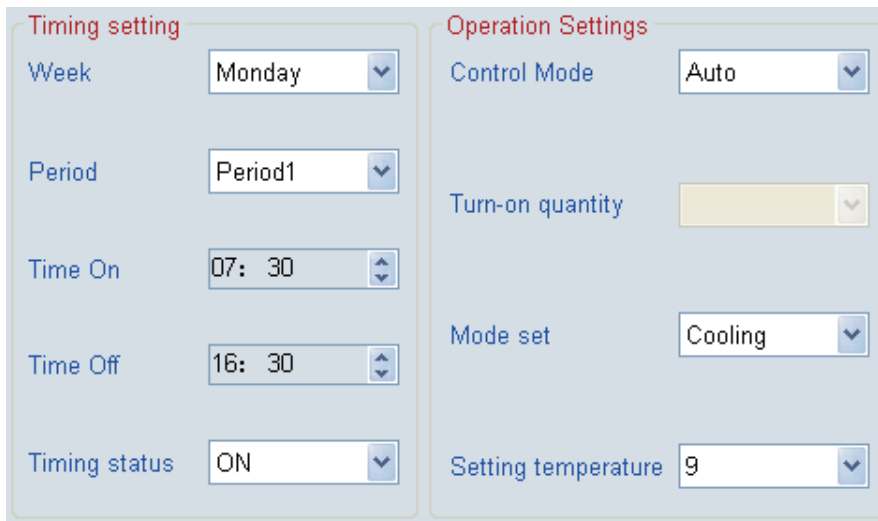

Fig.4-34

g. Delete key (See the ④ key in the figure) — select a Period and click the key, the current selected Weekly Timing setting period could be deleted. Click the key, window as Fig. 4-35 shows, click “OK” to delete Period. Successful delete the Period, message box as Fig. 4-36 will show.

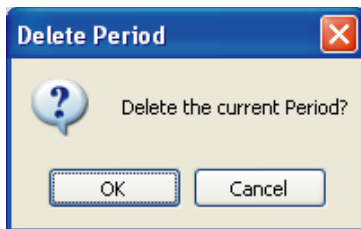

Fig.4-35

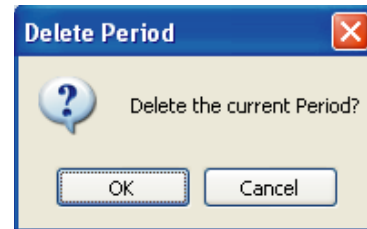

Fig.4-36

(1) Detail procedures of add a new Weekly Timing Schedule:

a. Select a wired controller: By clicking the “System diagram for weekly timing AC” wired controller icon at the left side in the wired controller, or by selecting the wired controller at the drop-down box of “KJR Address” .

b. Detail parameter for setting weekly timing schedule:

Week: Day (Monday、Tuesday、Wednesday、Thursday、Friday、Saturday、Sunday)

Period: Period 1、Period 2, set two Period per day.

Time On: Turn on time, when Time On selecting ” --: -- “ , then means do not turn on the unit , display as Fig 4-37.

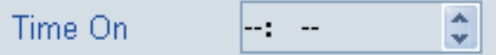

Fig.4-37

Time Off: Turn off time, when Time Off selecting " --: -- ", then means do not turn off the unit , display as Fig 4-38.



Fig.4-38

Timing Status: Drive up the weekly timing function in the current period or not.

Control Mode: Automatically drive-up mode

Mode set: Operation mode: Cooling, Heating, Water Pump

Setting temp.: Setting temp.

Note: The ON/OFF time of the weekly timing can not be at the same time point, the following will be not allowed for example if the ON time was 8:00 of Period1 and the OFF time was 8:00; and the OFF time of Period1 was 10:00 and the ON time of Period2 was 10:00. If there is error and then will pops-up prompt dialog box display as Fig. 4-39:

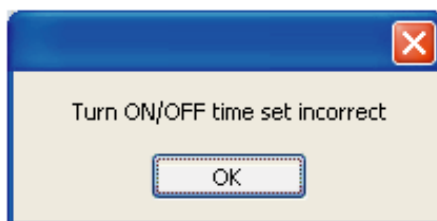

Fig.4-39

If no Timing Status has been set, a message box as Fig. 4-40 would pop up

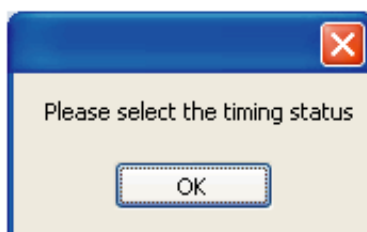

Fig.4-40

If no Control Mode has been set, a message box as Fig. 4-41 would pop up.

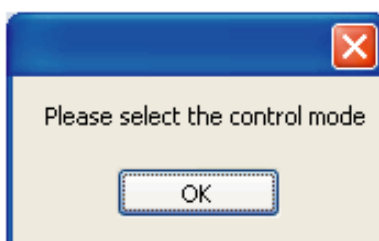

Fig.4-41

If no Mode set has been set, a message box as Fig. 4-42 would pop up.

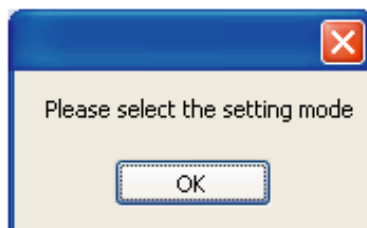

Fig.4-42

If no Setting temp. has been set, a message box as Fig. 4-43 would pop up.

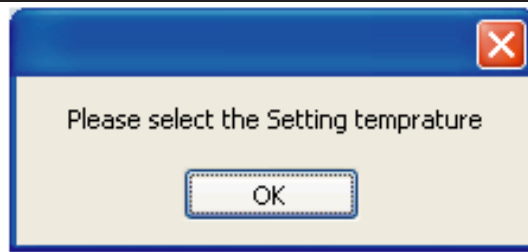

Fig.4-43

(2) Detail procedures of modify a Weekly Timing Schedule:

a、 Select a wired controller: By clicking the “System diagram for weekly timing AC” wired controller icon at the left side in the wired controller, or by selecting the wired controller at the drop-down box of “KJR Address” .

b、 Select a wired controller: By clicking the Period of the “System diagram for weekly timing AC” at the left side in the wired controller, or by selecting the wanted modified Period at the drop-down box of “Period” .

c、 Detail parameter for modifying weekly timing schedule:

Time On: Turn on time, when Time On selecting ” --: -- “ , then means do not turn on the unit , display as Fig 4-44.



Fig.4-44

Time Off: Turn off time, when Time Off selecting ” --: -- “ , then means do not turn off the unit , display as Fig 4-45.



Fig.4-45

Timing Status: Drive up the weekly timing function in the current period or not.

Control Mode: Automatically drive-up mode

Mode set: Heating、 Cooling、 Water Pump

Setting temp.: Setting temp.

If other parameters have been set, click “Save” key, a message box as the same as above” (1) Detail procedures of add a new Weekly Timing Schedule” will pop up.

Once the setting time is reach, system will set according to the setting parameter, window as Fig. 4-46 will display. When finish the set up, message box will close automatically.

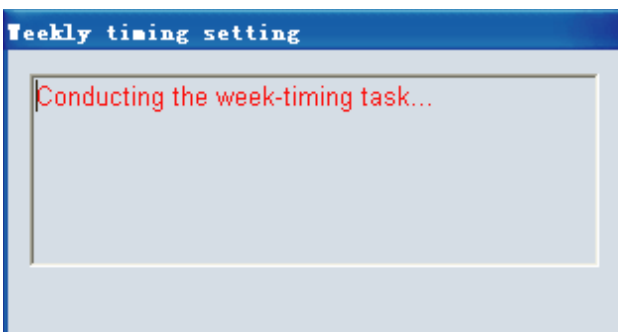
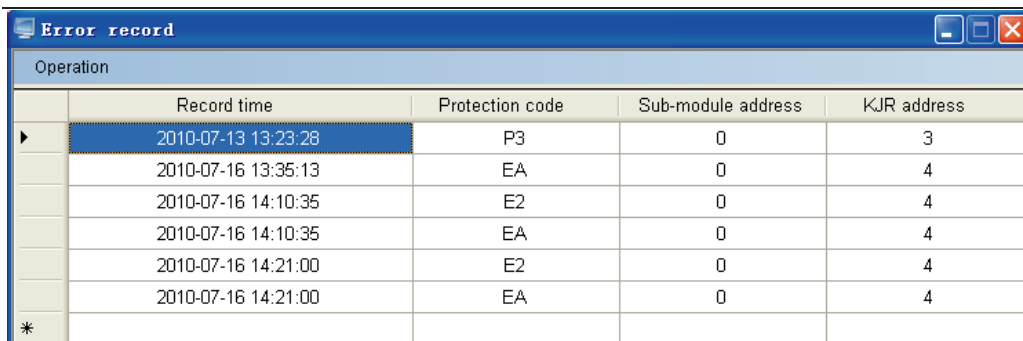

Fig.4-46

② “Error record” — Save the system operation error record, includes: Record time, Error prevented cord, Sub-module address and KJR address (see Fig. 4-47); click the “Record time”、“ Protection code”、“ Sub-module address”、“ KJR address” can proceed ordering(see Fig 4-48) ;“Clear all record ”in the Menu (See Fig. 4-49) could be used to delete all error records.



Operation				
	Record time	Protection code	Sub-module address	KJR address
▶	2010-07-13 13:23:28	P3	0	3
	2010-07-16 13:35:13	EA	0	4
	2010-07-16 14:10:35	E2	0	4
	2010-07-16 14:10:35	EA	0	4
	2010-07-16 14:21:00	E2	0	4
	2010-07-16 14:21:00	EA	0	4
*				

Fig.4-47

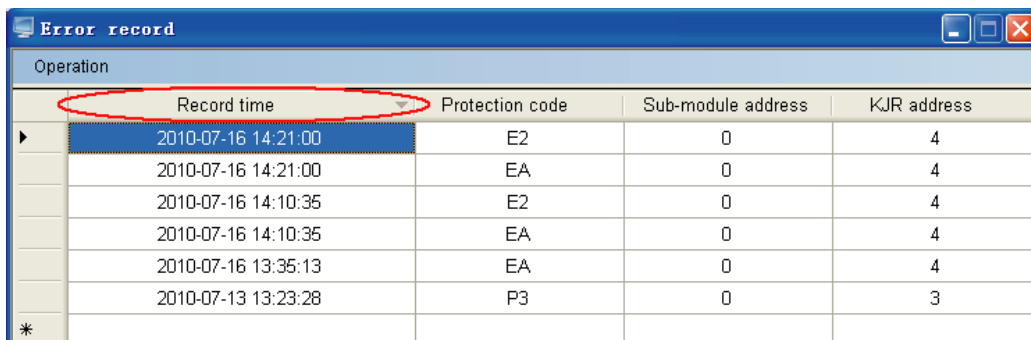

Operation				
	Record time	Protection code	Sub-module address	KJR address
▶	2010-07-16 14:21:00	E2	0	4
	2010-07-16 14:21:00	EA	0	4
	2010-07-16 14:10:35	E2	0	4
	2010-07-16 14:10:35	EA	0	4
	2010-07-16 13:35:13	EA	0	4
	2010-07-13 13:23:28	P3	0	3
*				

Fig.4-48



Fig.4-49

4) “Communication parameter” includes: “Serial port set” and “History set”. See Fig.4-50

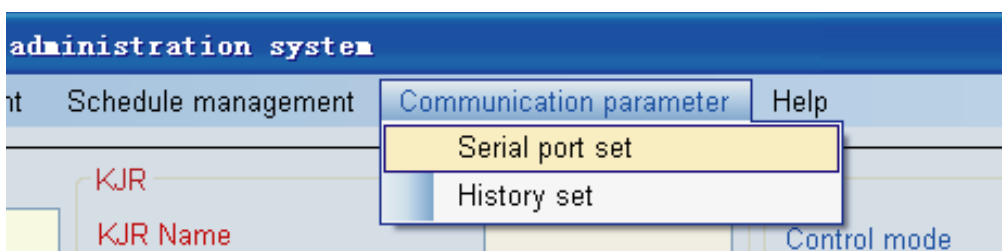

Fig.4-50

- ① Click “Serial port set”, window as Fig. 4-51 will pop up—— modify or select the serial port in computer. The available serial port source is captured by software, and saved at the optional list for user to select. Provided that the selected serial port has been occupied, once click “Apply” or “Enter”, a message box as Fig. 4-52 will pop up; if the serial port as is the current applying port, once click “Apply” or “Enter”, a message box as Fig. 4-53 will pop up.

Fig.4-51

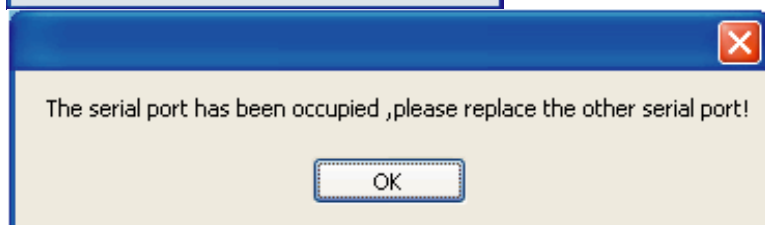
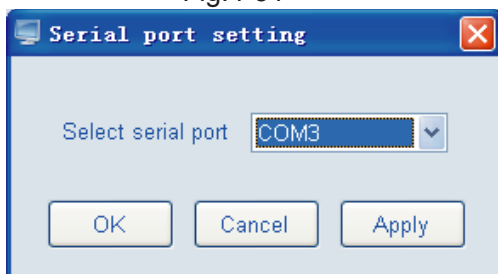

Fig.4-52

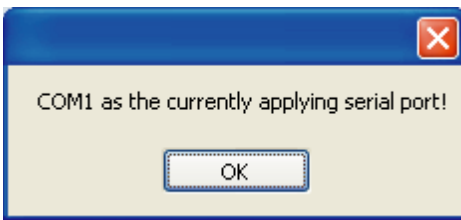

Fig.4-53

②Click “History set” , an interface as Fig. 4-54 displays — — —to modify or select the history error saving duration.

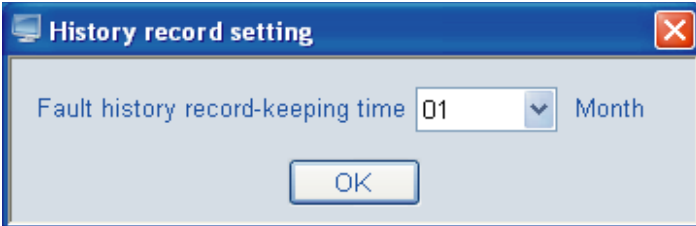

Fig.4-54

5) “Help” includes: “User guidance” and “About” . See Fig. 4-55

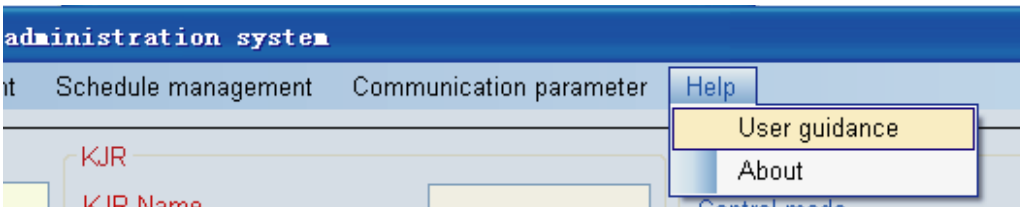

Fig.4-55

①Owner’s manual——Software application manual, i.e. this manual.

②About——some relevant software information

Wired controller lock/unlock

Provided that the selected wired controller in unlock status, the key would display “Lock KJR”(see Fig. 4-56), once successful lock the wired controller, the message box (see Fig. 4-57) would display, tells user that the setting is successful, then the key displays “Unlock KJR”(see Fig. 4-58); If the set failed, message box (Fig. 4-59) would display. If without select wired controller, message box as Fig. 4-60 will display.

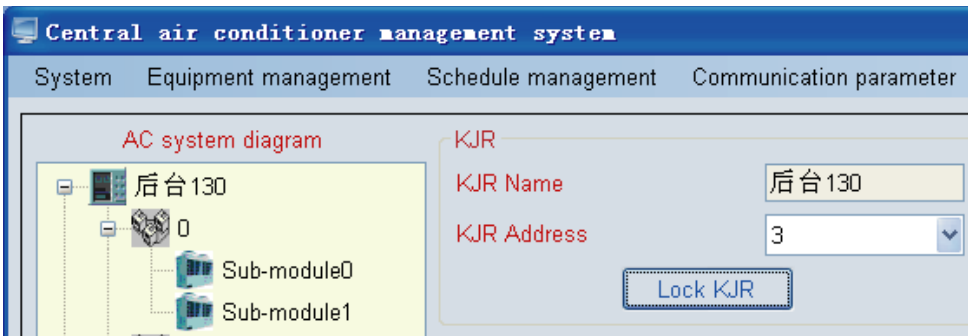

Fig.4-56



Fig.4-57

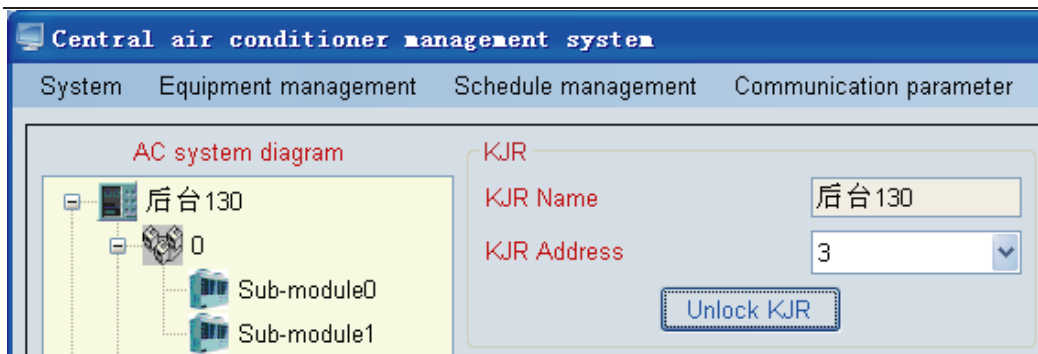

Fig.4-58

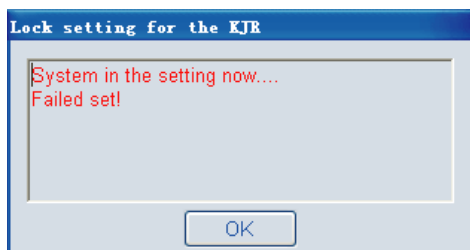

Fig.4-59

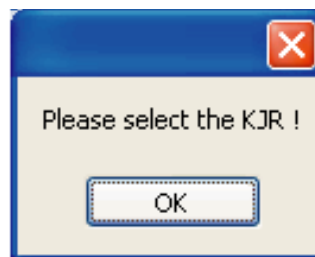

Fig.4-60

Provided that the selected wired controller in lock status, the key would display “Unlock KJR”(see Fig. 4-61), once successful unlock the wired controller, the message box (see Fig. 4-62) would display, then the key displays “Lock KJR”(see Fig. 4-63); if the set failed, message box (Fig. 4-64) would display, tells user that set failed because of timeout.

Fig.4-61

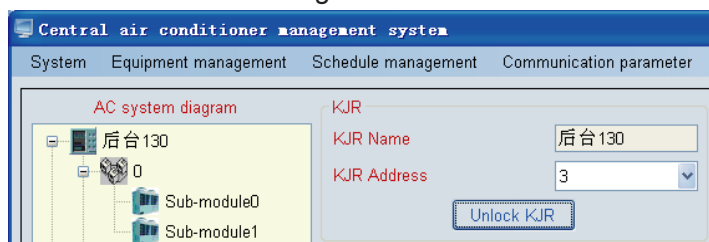

Fig.4-63

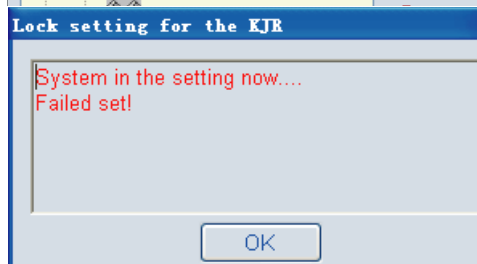
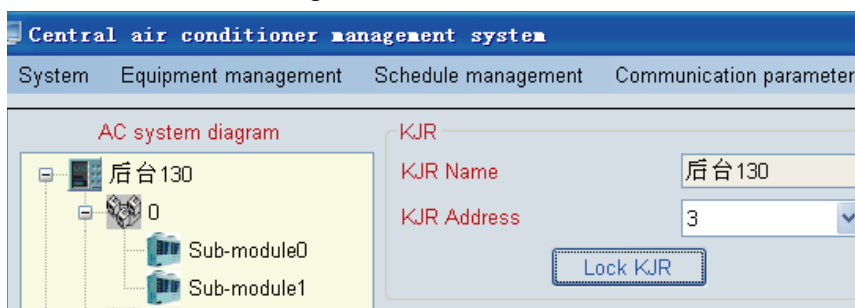

Fig.4-64

Query system parameter

Click “Query system parameter”, system will query the operating status (display the sub-module of 0 address’s operation status) and display the operative interface according to the selected wired controller (refrigeration system). In the querying, a message box (see Fig. 4-65) would pop up.

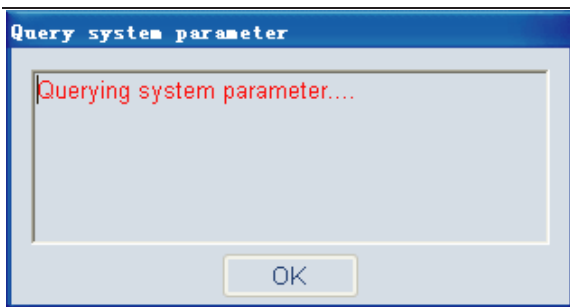

Fig.4-65

If successful query the system, a message box (see Fig. 4-66) will pop up and note you query success, and system parameter interface will update according to the query result. (Fig. 4-67)

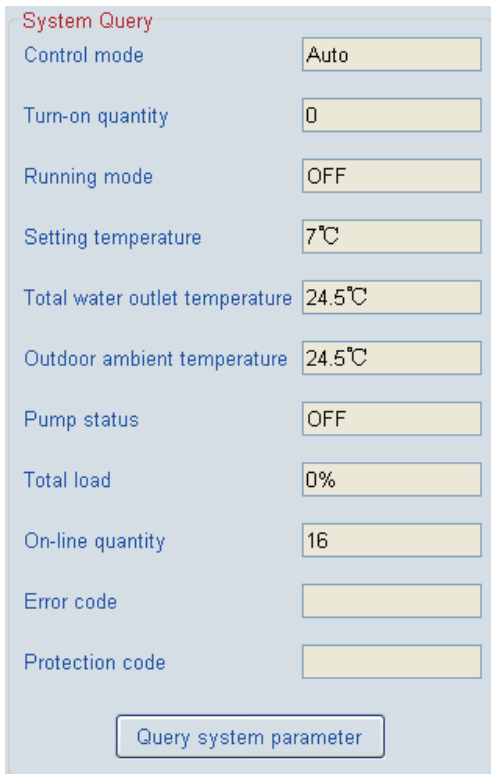
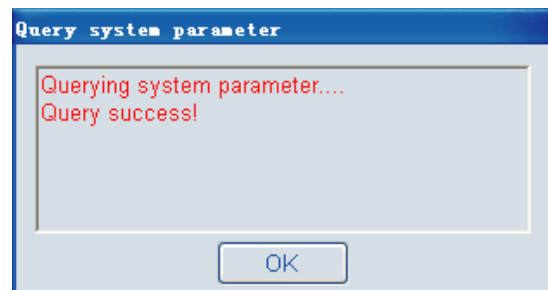

Fig.4-66

Fig.4-67



Whereas, "Query overtime" would display (see Fig. 4-68). Provided that the wired controller hasn't been selected, namely the wired controller address is empty, a message box as Fig 4-69 would pop up. The query performance failed.

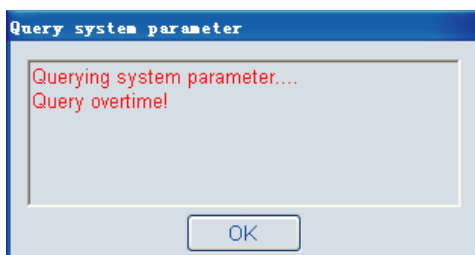
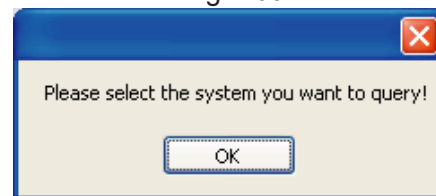

Fig.4-68

Fig.4-69



Provided that malfunction occur, the corresponding error code will show in the System Query; Provided that protection function perform, the corresponding protection code will show in the System Query; if move the mouse arrow to the these codes, a floating window as the follows Fig. 4-70 and 4-71 will appearance to giving the specific error or protection information.

System Query		Mode set	
Control mode	Auto	Setting temperature	
Turn-on quantity	0	Uniformly Set <input type="checkbox"/>	System operate set
Running mode	Heating	Sub-module Query	
Setting temperature	47°C	Air-chilling module	
Total water outlet temperature	—	Sub-module address	
Outdoor ambient temperature	25°C	Running mode	
Pump status	ON	Water outlet temperature of heat exchanger	
Total load	0%	Error code	
On-line quantity	8	Protection code	
Error code	E3	Total water outlet temperature sensor failure(Only for main unit)	
Protection code		Query	More parameters
Query system parameter			

Fig.4-70

System Query		Mode set	
Control mode	Auto	Setting temperature	
Turn-on quantity	4	Uniformly Set <input type="checkbox"/>	
Running mode	Heating	Sub-module Query	
Setting temperature	48°C	Air-chilling module	
Total water outlet temperature	25.5°C	Sub-module address	
Outdoor ambient temperature	25°C	Running mode	
Pump status	ON	Water outlet temperature of heat exchanger	
Total load	100%	Error code	
On-line quantity	4	Protection code	
Error code		System B Low-pressure protection	
Protection code	P3	Query	
Query system parameter			

Fig.4-71

Sub-module Query

Click the “Query”, system will query the operative status and display the information in the operation interface according to the current selected sub-module. In the querying, a message box (see Fig. 4-72) would pop up: “Querying sub-module parameter....” (see Fig. 4-73) to note you the query is successful and update the parameter interface (see Fig. 4-74) base on the query result; whereas, “Query overtime” (see Fig. 4-75) would display. Provided that sub-module hasn’t been selected, namely the sub-module address and the corresponding name are empty, a message box (see Fig. 4-76) would pop up. The query performance failed.

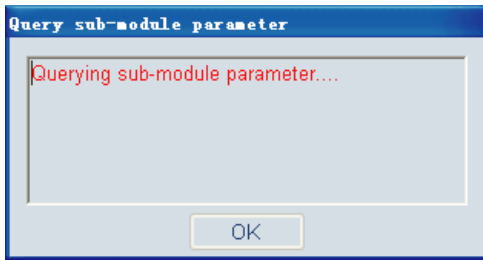

Fig.4-72

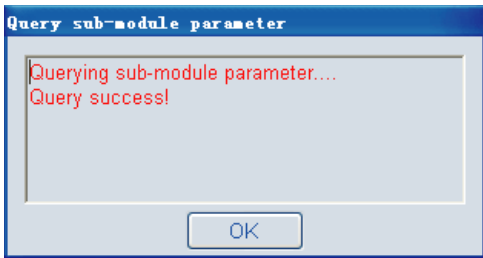

Fig.4-73

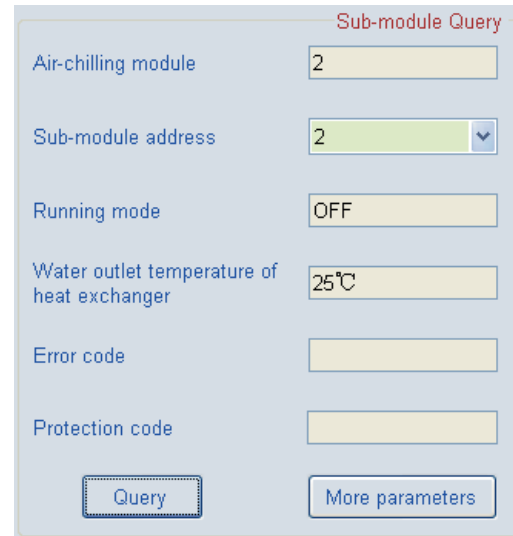

Fig.4-74

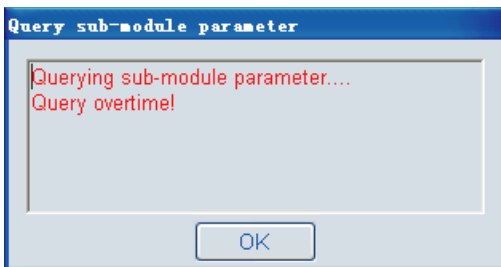

Fig.4-75

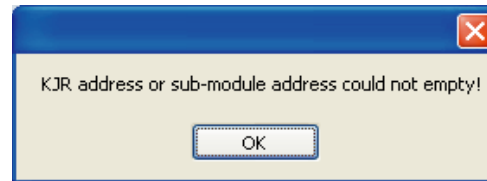

Fig.4-76

Provided that malfunction occur, the corresponding error code will show in the Sub-module query; Provided that protection function perform, the corresponding protection code will show in the Sub-module query; if move the mouse arrow to the these codes, a floating window as the follows Fig. 4-77 and 4-78 will appearance to giving the specific error or protection information.

Fig.4-77

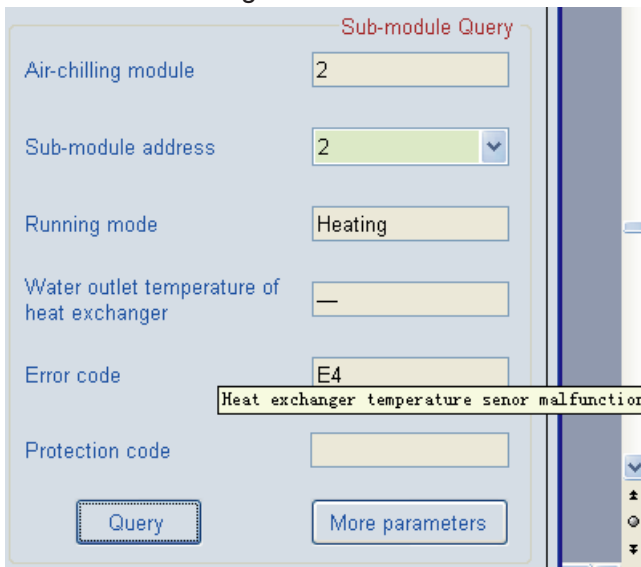
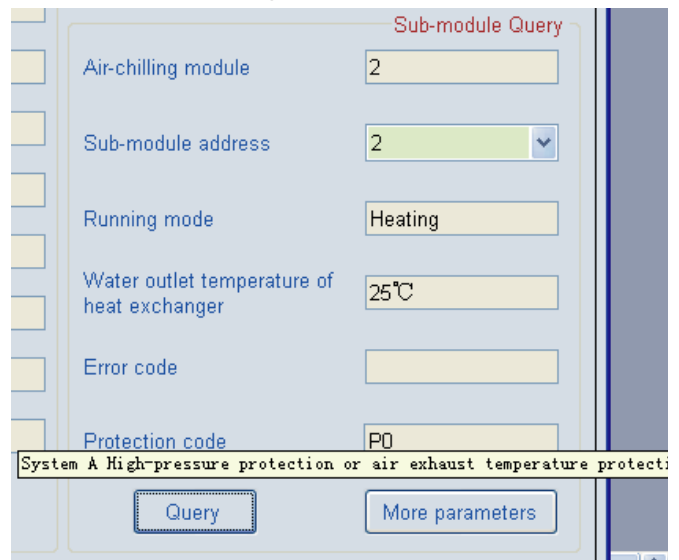

Fig.4-78



More parameters

Click More Parameters, you could query more data (See Fig.4-79). If the sub-module hasn't been selected, a message box as Fig. 4-80 would show. You must click a certain sub-module firstly, and then to click the "More parameters" key, more parameter could be queried; a message box (See Fig.4-81) will display informing more parameters are empty.

Fig.4-79

Parameter	Value
Condenser 1 temperature T3A	25°C
Condenser 2 temperature T3B	25°C
Compressor 1 current IA	0A
Compressor 1 current IB	0A
PMV 1 opening degree	80
PMV 2 opening degree	352
Outdoor fan	OFF
4-way valve 1	ON
4-way valve 2	ON
Electric auxiliary heater	OFF

Fig.4-80

Parameter	Value
Condenser 1 temperature T3A	
Condenser 2 temperature T3B	
Compressor 1 current IA	
Compressor 1 current IB	
PMV 1 opening degree	
PMV 2 opening degree	
Outdoor fan	
4-way valve 1	
4-way valve 2	
Electric auxiliary heater	

KJR address or sub-module address has to be non empty!

OK

Fig.4-81

System operate set

1) During setting, message boxes as following might display.

Click the "System operate set" in the conditioner of without wired controller has been selected, a message box as Fig. 4-82 would show.

Please select the system you want to set!

OK

Fig.4-82

Click the "System operate set" in the conditioner of although the wired controller has been set, all options in the System Set are empty (See Fig. 4-83), a message box as Fig. 4-84 would show.

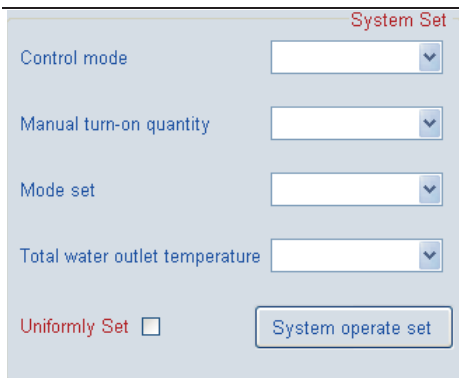

Fig.4-83

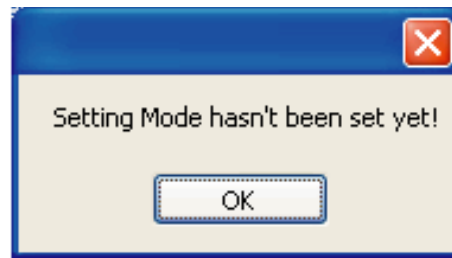

Fig.4-84

Click the “System operate set” in the conditioner of without Control Mode has been selected, a message box as Fig. 4-85 would show.

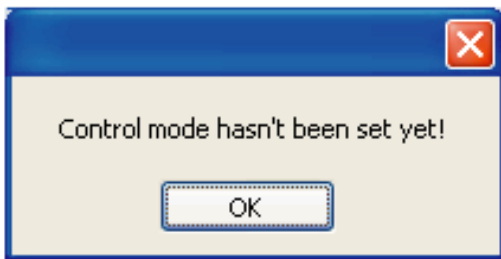

Fig.4-85

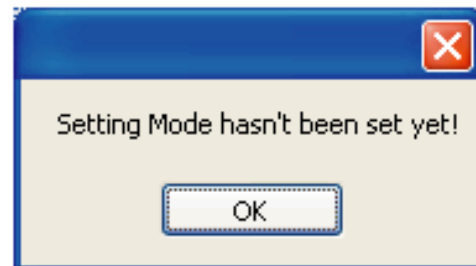

Fig.4-86

Click the “System operate set” in the conditioner of without Mode set has been selected, a message box as Fig. 4-86 would show.

Click the “System operate set” in the conditioner of without Setting temp. has been selected, a message box as Fig. 4-87 would show.

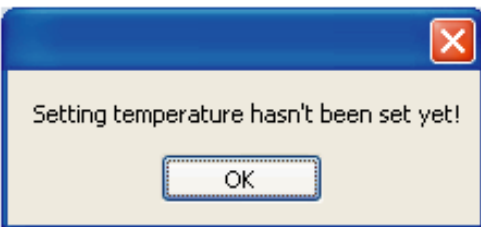

Fig.4-87

2) Set wired controller separately: Do not tick the “Uniformly Set” . Select the wanted set wired controller (refrigeration system) from the wired controller address column and select the corresponding set parameters, which include control Mode (Auto), Mode set (cooling/heating/Water pump/turn-off), Setting temp. (Cooling: 5~17°C; Heating:45~50°C). After set up all above parameters (See Fig. 4-88), please click the “System operate set” , system begins to set up. A message box (See Fig. 4-89) will pop up. Once successful setting, a message box as Fig. 4-90 will display to inform you Successful System Set, whereas, Failed System set as Fig. 4-91 will display.

Fig.4-88

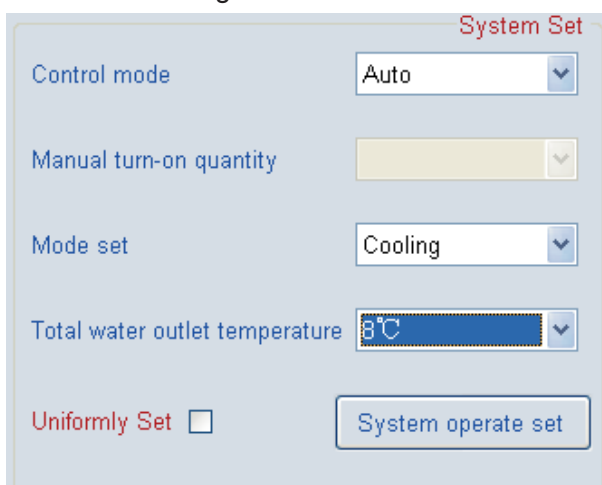

Fig.4-89

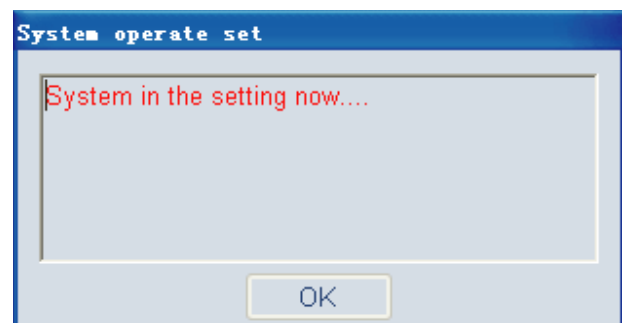

Fig.4-90

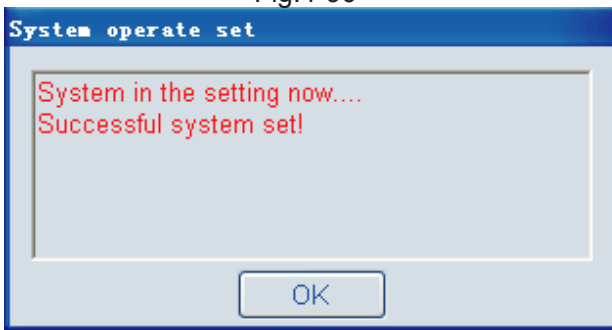
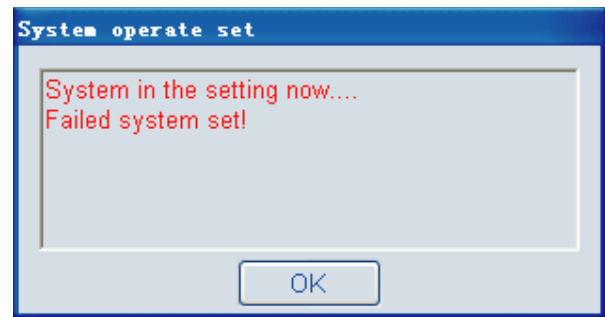

Fig.4-91



3) Uniformly set all wired controllers: Tick Uniformly Set as Fig. 4-92, and then select the corresponding parameters, click the System Operate Set, system starts to set up. A message box as Fig. 4-93 will display during the setting. Once successful setting, a message box as Fig. 4-94 will display to inform you Successful System Set, whereas, Failed System set as Fig. 4-95 will display. After all setting done, a message box (see Fig. 4-96) will display informing "Setting Finish".

Fig.4-92

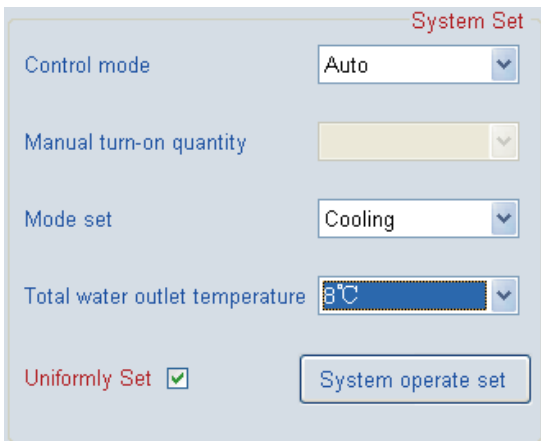

Fig.4-93

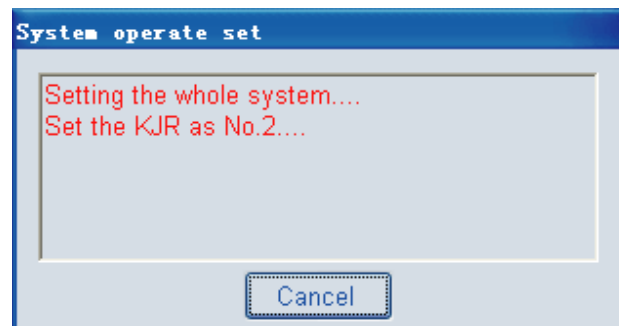

Fig.4-94

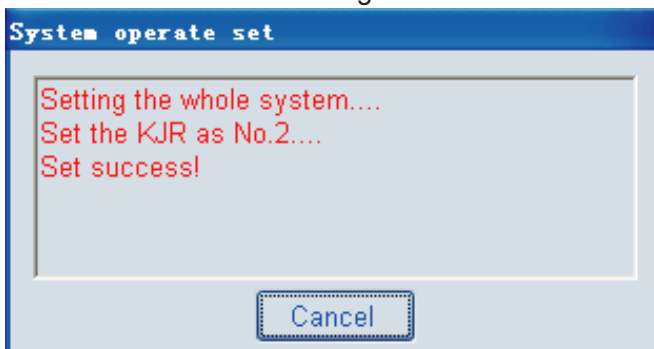

Fig.4-95

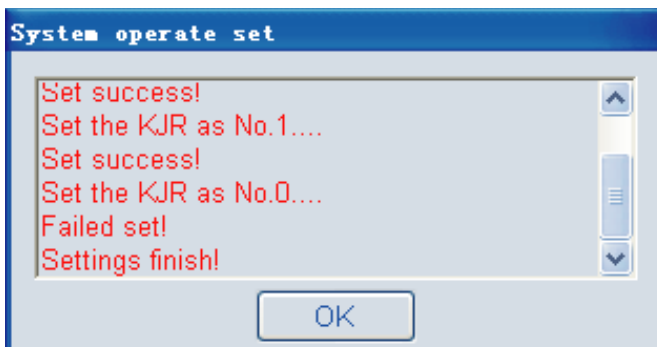
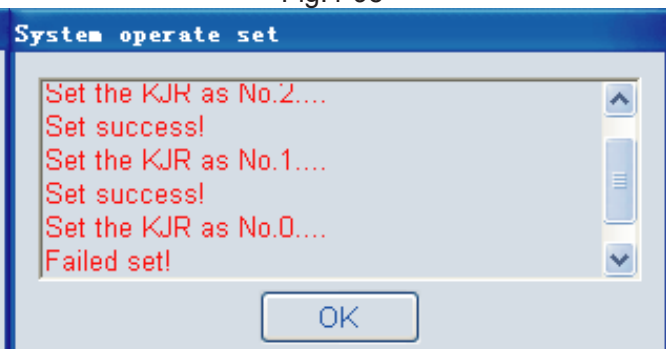

Fig.4-96

Remark :

The computer can use the names of serial ports for querying:

- 1、 Right-click the "My Computer" and select the "Properties" as Fig. 4-97.

Fig.4-98

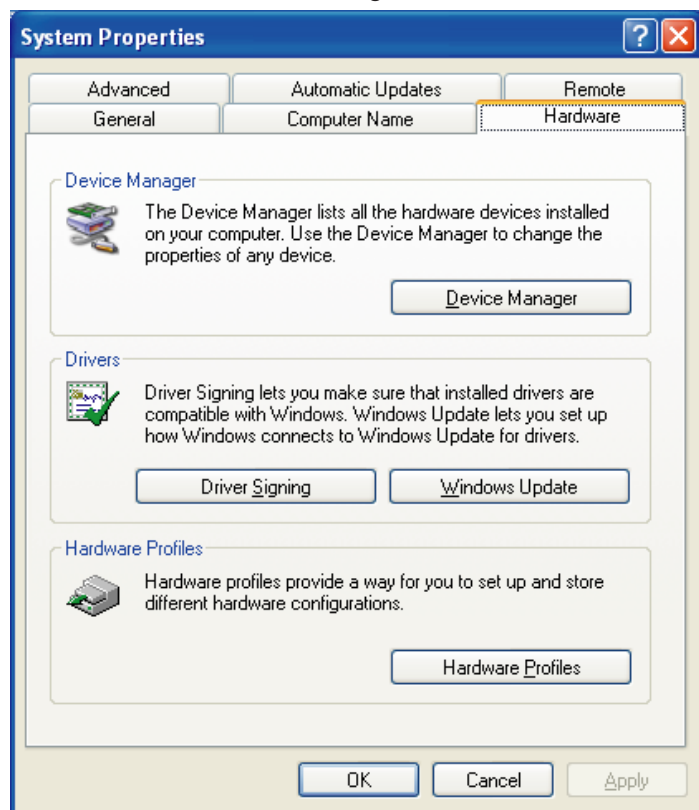
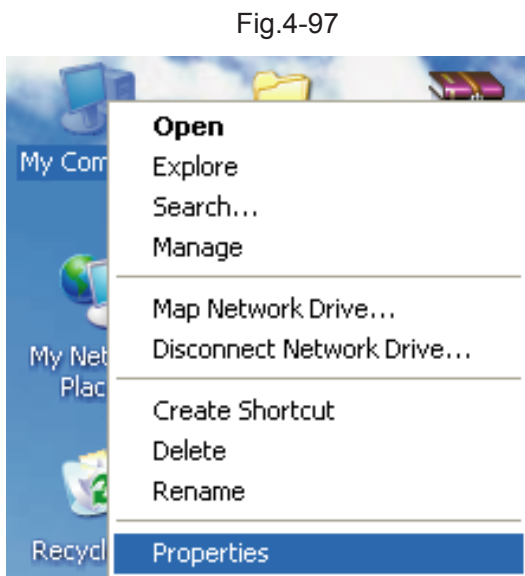

2、The window “System Properties” will be popped-up after selecting the “Properties”, and then select the “Device Manager” in the “Hardware” as Fig. 4-98

3、The window “Device Manager” will be showed up after clicking the “Device Manager, as Fig. 4-99.

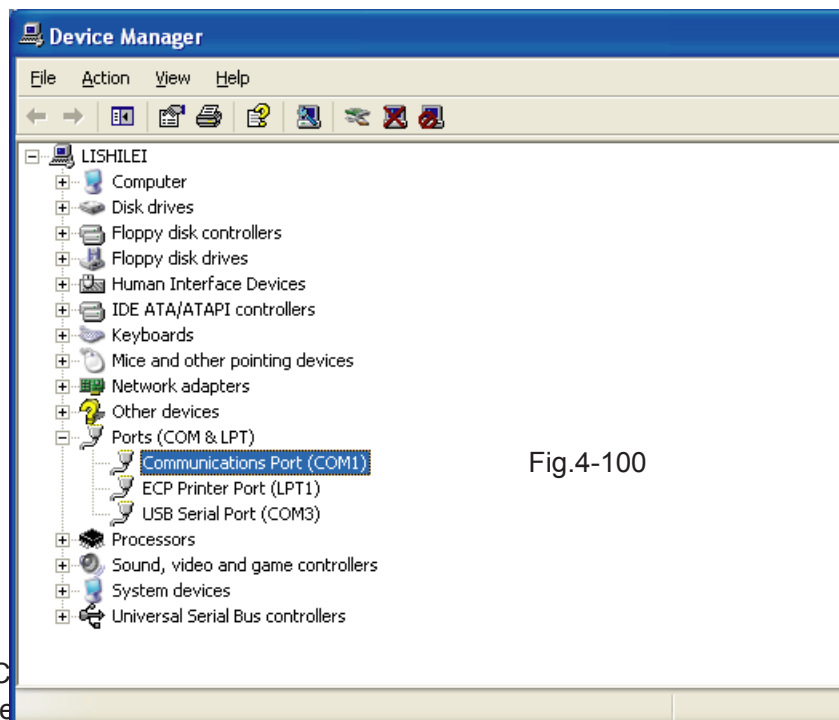
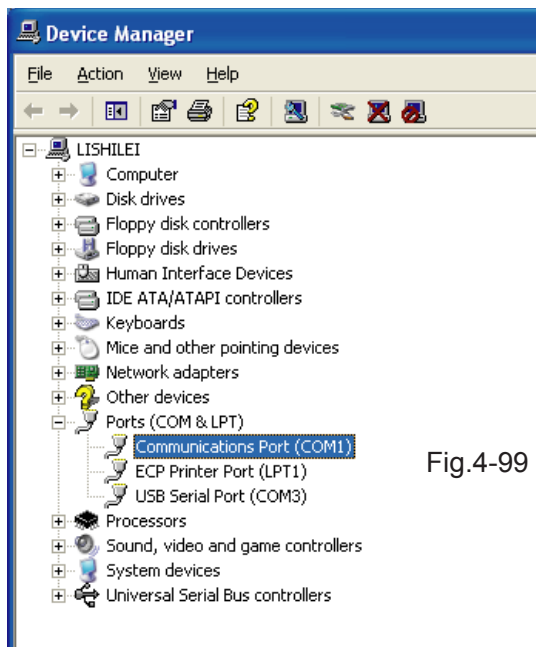

4、Click the icon “+” in front of the “Ports (COM & LPT)” as “COM” +number, these names are the usable may has more serial ports or no ports), as Fig. 4-100.

14.6 Lonworks (Optional)

14.6.1 Introduction

It is applied the central A/C system and the Building Management System (BMS) (namely Automated Building System) to realize the integration of A/C system and Building Management system.

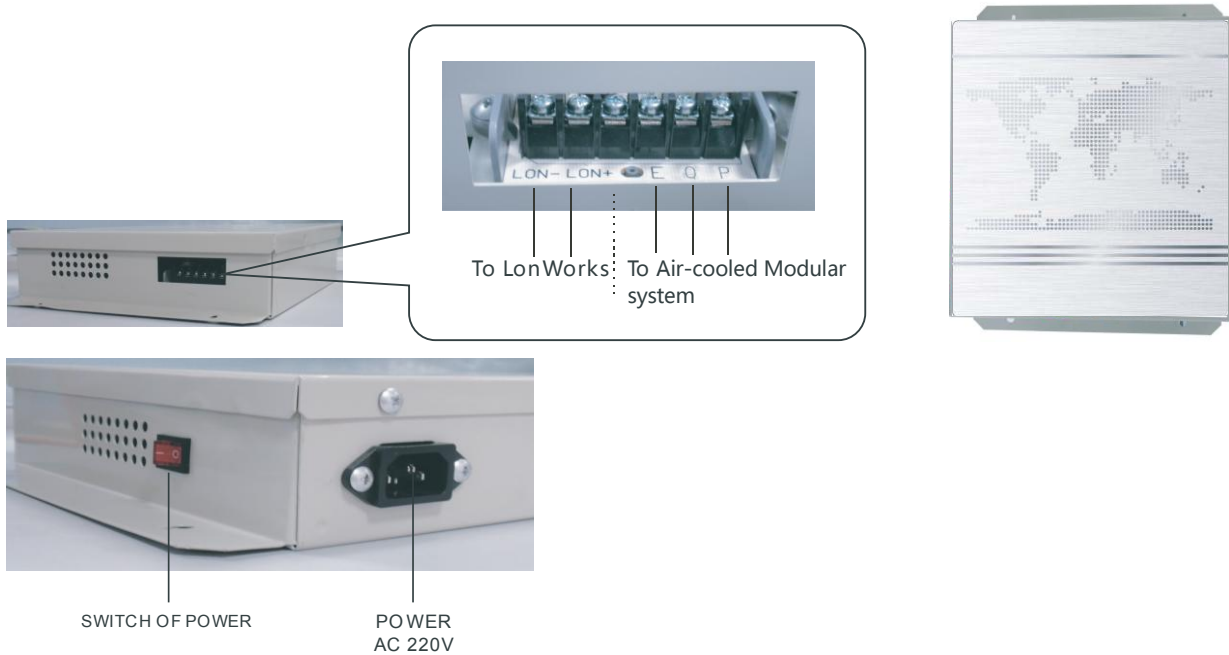

15.6.2 Features

Insert the central A/C system to LonWorks network.

Comply with LonMark Standard, gateways is an intelligent node base on LonWorks technique.

The core control module of node apply. Flash Memory, which application program could be downloaded on line.

Connect to LonWorks network by twisted pair wire, and the communication mode is nonpolar.

Provide with a LonWorks control interface for BMS by network variables complying with LonMark standard.

LonWorks interoperability Guidelines Version 3.4 Compliance LonWorks gateway between LonMark/LonTalk protocol andMDPP (Private protocol).

The gateway can convert the LonTalk protocol to the MDPP protocol.

Connection to 16(MAX) Air-cooled Modular units.

Valid address for each unit: 0x00~0x0F.

15.6.3 Specifications

NO.	FUNCTION	DESCRIPTION
1	Processor memorizer	Neure chip, 10MHz, 64K Flash memorizer
2	Functions	<ul style="list-style-type: none"> ● Hidden operation switch ● Operation LED (Red) ● Power LED(Green)
3	Transceiver	FTT-10A+isolating transformer
4	FTT-10A+isolating transformer	<ul style="list-style-type: none"> ● Voltage range: 177~254VAC ● MAX Current:2A
5	Operation ambient	<ul style="list-style-type: none"> ● temperature:0~70℃ ● Relative humidity:25~90%

6	Software configuration	<ul style="list-style-type: none"> ● LonMark standard allocative attribute ● Support Direct-Memory reading and writing by the LNS network management tool.
7	Communication port	Communication port
8	Size	31.9cm X 25.1cm X 6.1cm

14.6.4 External dimension

There are three installation methods as the following figure. Do not install the unit in any other orientation

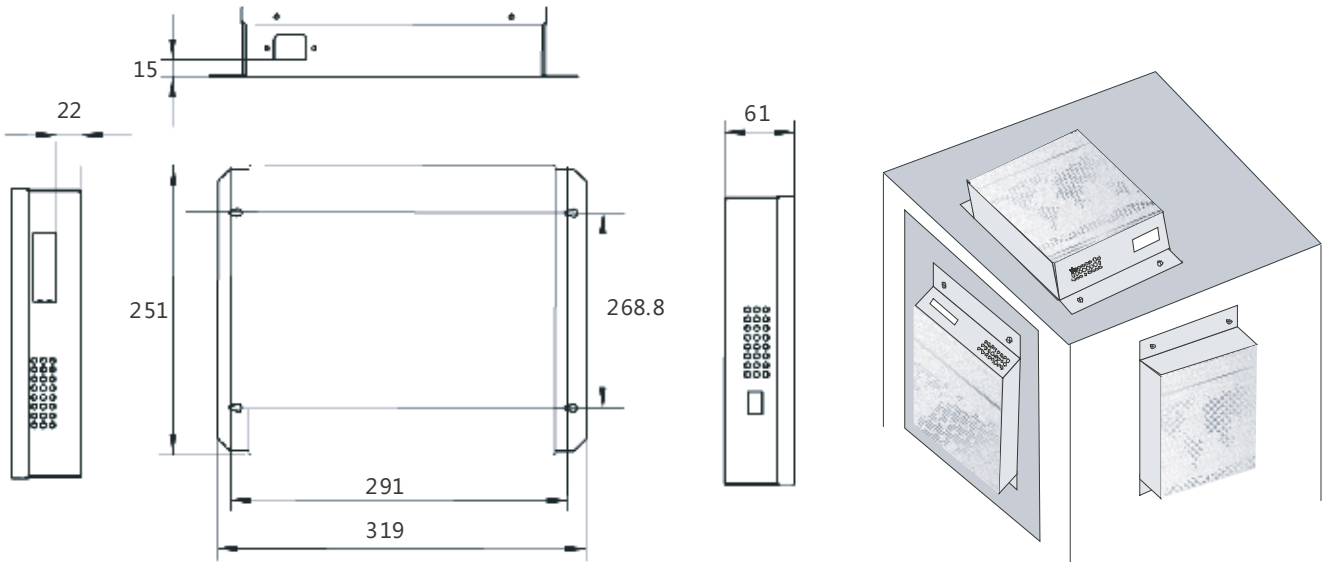

14.6.5 Connection Method

Connection Method 1

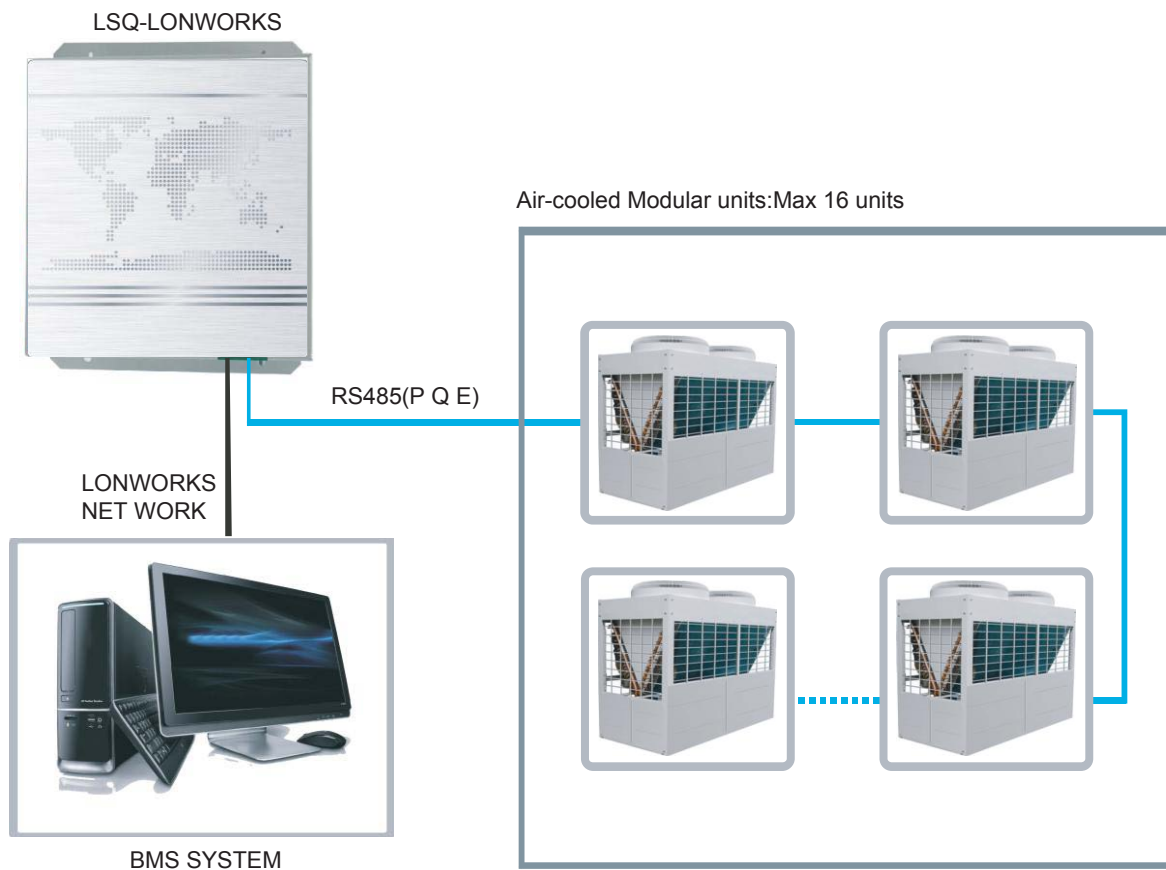

Connection Method 2:

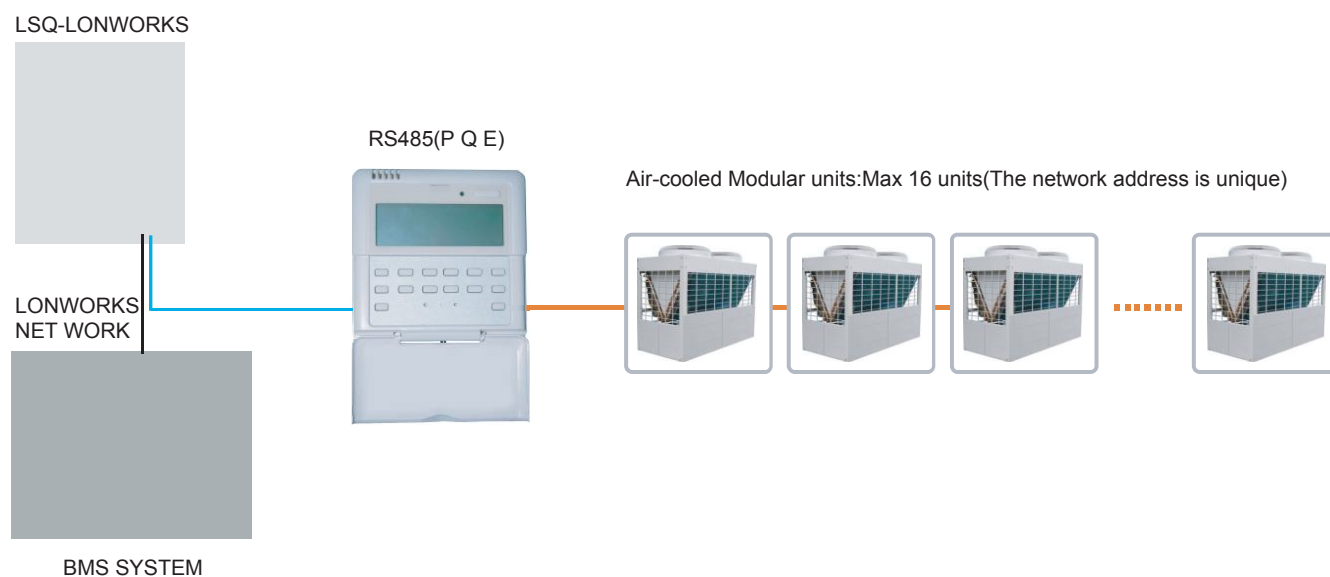

Caution

This system adopts the manner of shared network variable to manage A/C system, which cannot access the appointed A/C within central A/C system, until the co-responding network variable is modified to the one that is intended to access. This device consists of one transceivers (the following called Main controller for short). Main controller is responsible for querying and setting of 16 sets Air-cooled Modular units with addresses of 0~15 .

14.6.6 NetWork Variables of setting main controller

NO	Name	Network variable name	Network variable type	Data definition	Descriptions
1	Name	nciUARTBaud	SNVT_count	2:4800bps Initial value=2	Used for setting the baud rate of Rs485 port, and the gateway is used 4800 baud rate. The value is fixed to be 2.
2	Type	nciType	SNVT_count	0: KJR-120A/MBE 1: KJR-08B/BE Initial value=0	Gateway type, need to be set as the actual condition. The initial value is 0
3	Address	NciCtrl_Addr	SNVT_count	240,241...255 Initial value=240	The gateway address of the Air-cooled Modular unit system. "Address" must be set the corresponding value, as displayed in Table A. The initial value is 240.

nciCtrl_Addr	Corresponding address of wired controller
255	0
254	1
253	2
252	3
251	4
250	5
249	6
248	7
247	8
246	9
245	10
244	11
243	12
242	13
241	14
240	15

 **Caution**

First power on, it needs to set the gateway property as the actual conditioner, then connect the gateway which has been set to the Air-cooled Modular system.

* In a Air-cooled Modular system, there are wire controller and gateway, the address which the address variable of the gateway (nciCtrl_Addr) corresponds to the address of wire controller must be larger than all the wire controller addresses (As displayed in Table A).

Gateway address setting example: One Air-cooled Modular system, there are two wired controllers, the addresses are 0, 13, and as displayed in Table A, the gateway must be set to 241 or 240, for only 241 and 240 corresponding addresses of wired controller are larger than the wired controller address 13.

The Lonworks gateway can be used as a wired controller. If you have chosen our production, please check the wired controller in the Air-cooled Modular unit first before using the gateway.

if the wired controller in the Air-cooled Modular unit is KJR-120A/MBE, the nciType should be set as 0. This is very important.

15.6.7 The network variables which are assigned to the Air-cooled Modular system:

The network variable of Air-cooled Modular system: 4 input network variables, used for setting; 8 output network variables, used for query. As the following figure:

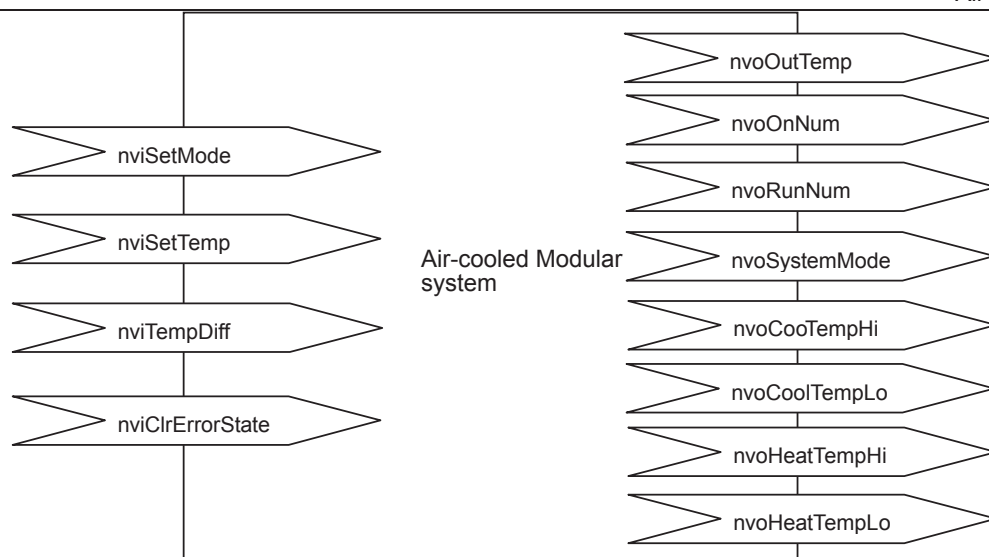

Input network variable of air-cooled modular system

NO	Name	Network variable name	Network variable type	Date definition	Descriptions
1	Mode setting	nviSetMode	SNVT_hvac_mode	HVAC_COOL: Cool Mode HVAC_HEAT: Heat Mode HVAC_FAN_ONLY: Water pump Mode HVAC_OFF: Off Mode	Setting the running mode of Air-cooled Modular system. Except the mode on the left side, the other mode will be executed according to Water pump Mode.
2	Total water outlet temperature setting	nviSetTemp	SNVT_temp_p	The cooling and heating effective temperature range fixing of old Air-cooled Modular: Cooling 5~17 Heating 45~50 The cooling and heating effective temperature range of new Air-cooled Modular must be set according to the "Output network variable of Air-cooled Modular system": Cooling: Max. cooling value: nvoCooTempHi Min. cooling value: nvoCoolTempLo Heating: Max. heating value: nvoHeatTempHi Min. heating vaule: nvoHeatTempLo	Setting the total water outlet temperature of air-cool heat pump unit sytem. * The setting value of temperature must strictly accord to the range displayed on the left side. Otherwise, it could bring a great damage to our Air-cooled Modular system. * Explanation: 1. old Air-cooled Modular means that the nciType should be set as 1. 2. new Air-cooled Modular means that the nciType should be set as 0.
3	Return difference temperature setting	nviTempDiff	SNVT_count	2, 3, 4, 5	Setting return difference temperature. The default value is 2 * Which are smaller than 2, then be setting as 2; which are bigger than 5, then be setting as 5. * This variable is only effective when the nciType being set as 0.
4	Manual clearing error	nviClrError State	SNVT_switch	0.0 0 None manual clearing error 0.0 1 Manual clearing error	Only for manual clearing error * This variable is only effective when the nciType being set as 0.

Output network variable of air-cooled modular chiller unit system

NO	Name	Network variable name	Network variable type	Date definition	Descriptions
1	Running state	nvoSystem Mode	SNVT_hvac_mode	HVAC_COOL: Cool Mode HVAC_HEAT: Heat Mode HVAC_FAN_ONLY: Water pump Mode HVAC_OFF:Off Mode	Display the running mode of Air-cooled Modular system. The initial value of first power on is HVAC_AUTO
2	Setting water outlet temperature	nvoOutTemp	SNVT_temp_p	Detail data refers to the nviSetTemp in the input variable of Air-cooled Modular system	Display the total water outlet temperature of Air-cooled Modular sytem.
3	Qty. of on-line units	nvoOnNum	SNVT_count	0~16	Display the qty. of on-line module unit of Air-cooled Modular units.
4	Qty. of operating unit module	nvoRunNum	SNVT_count	0~16	Display the qty. of operating module unit of Air-cooled Modular units.
5	Details of on-line unit module	nvoComState	SNVT_state	0: Off-line 1: On-line	Display the on-line state of unit module If No.0 unit module off-line, all bit of this network variable will change to be 0 after 1 min.
6	Setting the min. value of total water outlet under Cool mode	nvoCool TempLo	SNVT_count	It could have different values if the Air-cooled Modular units" model is different.	Under setting cool mode of Air-cooled Modular system, setting the min. value of the total water outlet temperature * This network variable only is effective when the nciType being set as 0. otherwise this network variable is invalid value.
7	Setting the max. value of total water outlet under Cool mode	nvoCool TempHi	SNVT_count	It could have different values if the Air-cooled Modular units" model is different.	Under setting cool mode of Air-cooled Modular system, setting the max. value of the total water outlet temperature * This network variable only is effective when the nciType being set as 0. Otherwise,this variable is invalid value.
8	Setting the min. value of total water outlet under Heat mode	nvoHeat TempLo	SNVT_count	It could have different values if the Air-cooled Modular units" model is different.	Under setting heat mode of Air-cooled Modular system, setting the min. value of the total water outlet temperature * This network variable only is effective when the nciType being set as 0. otherwise this network variable is invalid value.
9	Setting the max. value of total water outlet under Heat mode	nvoHeat TempHi	SNVT_count	It could have different values if the Air-cooled Modular units" model is different.	Under setting heat mode of Air-cooled Modular system, setting the max. value of the total water outlet temperature * This network variable only is effective when the nciType being set as 0. Otherwise,this variable is invalid value.

The network variable which is assigned to each unit module: 6 output network variable, used for displaying detail parameters of unit modules.



NO	Name	Network variable name	Network variable type	Date definition		Descriptions
1	Running mode	nvoRunModes[n]	SNVT_hvac_mode	HVAC_COOL: Cool Mode HVAC_HEAT: Heat Mode HVAC_FAN_ONLY: Water pump Mode HVAC_OFF: Off Mode		Operating mode of unit * n means the address of the unit, nvoRunMode S[1] means the running mode of unit which address is 1.
2	Error code	nvoErrorCode[n]	SNVT_lev_disc	bit0 : E0 bit8 : E8 bit1 : E1 bit9 : E9 bit2 : E2 bit10: EA bit3 : E3 bit11: EB bit4 : E4 bit12: EC bit5 : E5 bit13: ED bit6 : E6 bit14: EE bit7 : E7 bit15: EF		Error code of unit * n means the address of the unit, nvoErrorCode [1] means the error code of unit which address is 1.
3	Protection code	nvoProtectCode[n]	SNVT_temp_p	bit0 : P0 bit8 : P8 bit1 : P1 bit9 : P9 bit2 : P2 bit10: PA bit3 : P3 bit11: PB bit4 : P4 bit12: PC bit5 : P5 bit13: PD bit6 : P6 bit14: PE bit7 : P7 bit15: PF		Protection code of unit module * n means the address of the unit module, nvoProtectCode [1] means the protection code of unit which address is 1.
4	Unit module	nvoTemp[n]	UNVT_md	nvoOutTempS	Water outlet temperature of unit	Each temperature parameters of unit. *There are 6 temperature parameters in nvoTemp[n]. All the temperature type is signed long. * n means the address of the unit, nvoTemp [1] means the temperature parameters of unit which address is 1.
				nvoTempBackS	Water inlet temperature of unit. This variable is only effective when the nciType being set as 0.	
				nvoPreFrostTemp	Anti-Freezing temperature of unit. This variable is only effective when the nciType being set as 0.	
				nvoT3A	Condenser temp T3A	
				nvoT3B	Condenser temp T3B	
				nvoT4	Outdoor temperature T4. This variable is only effective when the nciType being set as 0.	

NO	Name	Network variable name	Network variable type	Date definition	Descriptions
5	Current of Compressor A	nvoCompA Current[n]	SNVT_count	0~250A	Compressor A current of unit. *n means the address of the unit, nvoCompACurrent[1] means the Compressor A current of unit which address is 1.
6	Current of Compressor B	nvoCompB Current[n]	SNVT_count	0~250A	Compressor B current of unit. *n means the address of the unit, nvoCompBCurrent[1] means the Compressor B current of unit which address is 1.

Operation instruction:

1. Some parameters setting range of the air-cooled modular chiller is smaller than the LNS setting range, please refers to the setting expected value of the operation manual of the Air-cooled Modular;
2. When use the LNS to operate the air-cooled modular chiller, it is suggested that set the mode, the setting temperature to reach the expected effect.

Appendix**1. Accessories**

Item	Name of accessory	Type	Qty	Shape	Usage
1	Installation and owner's manual	---	1		Installation and using instruction.
2	The total outlet water temperature test kit	LSQWRF65M/A-C.ZL.10	1		Inspection the temperature of total outlet water.
3	Wired controller	KJR -120A/MBE	1		Control the system.

2. Temperature-Resistance characteristic sheet for pipe temperature sensor, ambient temperature sensor, inlet water temperature sensor and outlet water temperature sensor.

Sensor characteristic sheet **Unit:** Temp:°C--K, Ratio:KΩ

Temp.	Ratio	Temp.	Ratio	Temp.	Ratio	Temp.	Ratio
-20	115.266	20	12.6431	60	2.35774	100	0.62973
-19	108.146	21	12.0561	61	2.27249	101	0.61148
-18	101.517	22	11.5	62	2.19073	102	0.59386
-17	96.3423	23	10.9731	63	2.11241	103	0.57683
-16	89.5865	24	10.4736	64	2.03732	104	0.56038
-15	84.219	25	10	65	1.96532	105	0.54448
-14	79.311	26	9.55074	66	1.89627	106	0.52912
-13	74.536	27	9.12445	67	1.83003	107	0.51426
-12	70.1698	28	8.71983	68	1.76647	108	0.49989
-11	66.0898	29	8.33566	69	1.70547	109	0.486
-10	62.2756	30	7.97078	70	1.64691	110	0.47256
-9	58.7079	31	7.62411	71	1.59068	111	0.45957
-8	56.3694	32	7.29464	72	1.53668	112	0.44699
-7	52.2438	33	6.98142	73	1.48481	113	0.43482
-6	49.3161	34	6.68355	74	1.43498	114	0.42304
-5	46.5725	35	6.40021	75	1.38703	115	0.41164
-4	44	36	6.13059	76	1.34105	116	0.4006
-3	41.5878	37	5.87359	77	1.29078	117	0.38991
-2	39.8239	38	5.62961	78	1.25423	118	0.37956
-1	37.1988	39	5.39689	79	1.2133	119	0.36954
0	35.2024	40	5.17519	80	1.17393	120	0.35982
1	33.3269	41	4.96392	81	1.13604	121	0.35042
2	31.5635	42	4.76253	82	1.09958	122	0.3413
3	29.9058	43	4.5705	83	1.06448	123	0.33246
4	28.3459	44	4.38736	84	1.03069	124	0.3239
5	26.8778	45	4.21263	85	0.99815	125	0.31559
6	25.4954	46	4.04589	86	0.96681	126	0.30754
7	24.1932	47	3.88673	87	0.93662	127	0.29974
8	22.5662	48	3.73476	88	0.90753	128	0.29216
9	21.8094	49	3.58962	89	0.8795	129	0.28482
10	20.7184	50	3.45097	90	0.85248	130	0.2777
11	19.6891	51	3.31847	91	0.82643	131	0.27078
12	18.7177	52	3.19183	92	0.80132	132	0.26408
13	17.8005	53	3.07075	93	0.77709	133	0.25757
14	16.9341	54	2.95896	94	0.75373	134	0.25125
15	16.1156	55	2.84421	95	0.73119	135	0.24512
16	15.3418	56	2.73823	96	0.70944	136	0.23916
17	14.6181	57	2.63682	97	0.68844	137	0.23338
18	13.918	58	2.53973	98	0.66818	138	0.22776
19	13.2631	59	2.44677	99	0.64862	139	0.22231

3. Temperature-Resistance characteristic sheet for discharge temperature sensor of digital compressor.

Sensor characteristic sheet

Unit: temp:°C--K, Ratio:KΩ

Temp	Ratio	Temp	Ratio	Temp	Ratio	Temp.	Ratio	Temp.	Ratio
-40	2889.60000	13	148.39300	66	17.29460	119	3.45032	172	0.97524
-39	2704.61400	14	141.59040	67	16.70980	120	3.35400	173	0.95632
-38	2532.87200	15	135.14040	68	16.13360	121	3.26198	174	0.93826
-37	2373.34200	16	129.00000	69	15.59180	122	3.17340	175	0.92020
-36	2225.07800	17	123.17780	70	15.06720	123	3.08740	176	0.90214
-35	2087.22000	18	117.65660	71	14.55980	124	3.00484	177	0.88494
-34	1957.44600	19	112.41060	72	14.07820	125	2.92400	178	0.86774
-33	1836.70200	20	107.43980	73	13.60520	126	2.85090	179	0.85054
-32	1724.38600	21	102.70120	74	13.15800	127	2.78038	180	0.83420
-31	1619.72400	22	98.19480	75	12.72800	128	2.71158	181	0.81614
-30	1522.20000	23	93.92060	76	12.30660	129	2.64450	182	0.79808
-29	1430.54120	24	89.86140	77	11.91100	130	2.58000	183	0.78088
-28	1345.07440	25	86.00000	78	11.52400	131	2.51636	184	0.76454
-27	1265.35240	26	82.31060	79	11.15420	132	2.45444	185	0.74820
-26	1190.94520	27	78.81040	80	10.79300	133	2.39424	186	0.73358
-25	1121.45720	28	75.47360	81	10.44900	134	2.33576	187	0.71982
-24	1056.14020	29	72.30020	82	10.12220	135	2.27900	188	0.70606
-23	995.10600	30	69.28160	83	9.80400	136	2.22396	189	0.69230
-22	938.04500	31	66.39200	84	9.49440	137	2.17150	190	0.67940
-21	884.66480	32	63.64860	85	9.20200	138	2.11990		
-20	834.71600	33	61.02560	86	8.91820	139	2.07002		
-19	787.65680	34	58.53160	87	8.64300	140	2.02100		
-18	743.58180	35	56.15800	88	8.37640	141	1.97370		
-17	702.29320	36	53.88760	89	8.11840	142	1.92812		
-16	663.59320	37	51.72040	90	7.86900	143	1.88340		
-15	627.28400	38	49.65640	91	7.64110	144	1.83954		
-14	593.03020	39	47.69560	92	7.40460	145	1.79740		
-13	560.88340	40	45.81220	93	7.18530	146	1.75354		
-12	530.71460	41	44.00620	94	6.97288	147	1.71140		
-11	502.36900	42	42.29480	95	6.76820	148	1.67012		
-10	475.74340	43	40.65220	96	6.57126	149	1.62970		
-9	450.57120	44	39.07840	97	6.38120	150	1.59100		
-8	426.90400	45	37.58200	98	6.19716	151	1.54886		
-7	404.64720	46	36.14580	99	6.02000	152	1.50844		
-6	383.70620	47	34.76120	100	5.84800	153	1.46888		
-5	363.98640	48	33.44540	101	5.68632	154	1.43018		
-4	345.31580	49	32.18980	102	5.52980	155	1.39320		
-3	327.73740	50	30.98580	103	5.37930	156	1.36224		
-2	311.16520	51	29.83340	104	5.23310	157	1.33214		
-1	295.55620	52	28.72400	105	5.09120	158	1.30290		
0	280.82440	53	27.66620	106	4.95360	159	1.27452		
1	266.85800	54	26.65140	107	4.82030	160	1.24700		
2	253.68280	55	25.67960	108	4.69216	161	1.21948		
3	241.24720	56	24.75080	109	4.56660	162	1.19368		
4	229.49960	57	23.85640	110	4.44620	163	1.16788		
5	218.40560	58	23.00500	111	4.32322	164	1.14208		
6	207.87060	59	22.17940	112	4.20454	165	1.11800		

7	197.91180	60	21.39680	113	4.08930	166	1.09650		
8	188.49480	61	20.64000	114	3.97750	167	1.07500		
9	179.59380	62	19.90900	115	3.87000	168	1.05436		
10	171.16580	63	19.22100	116	3.75992	169	1.03458		
11	163.15920	64	18.55020	117	3.65328	170	1.01480		
12	155.57400	65	17.91380	118	3.55008	171	0.99502		