

Installation, operating and maintenance



HYDROLEAN™ MWC™ - MRC

Water cooled liquid chillers



WATER COOLED CHILLERS AND SPLIT UNITS



INSTALLATION OPERATION MAINTENACE MANUAL

Ref: WC_CHILLER-IOM-1011-E

The present manual applies to the following Chiller versions :

HYDROLEAN™ Range: SWC-SWH-SWR

MWC™ Range: MWC-MRC

<p><i>Our company is a member of the Eurovent Certification Program, all LENNOX chillers are tested and rated in accordance with Eurovent certification program</i></p>	
<p><i>Our products comply with the European standards</i></p>	
<p><i>Product designed and manufactured under a quality management system certified to ISO 9001</i></p>	

All the technical and technological information contained in this manual, including any drawing and technical descriptions provided by us, remain the property of LENNOX and must not be utilised (except in operation of this product), reproduced, issued to or made available to third parties without the prior written agreement of LENNOX.

1 – PREFACE	3
2 – WARRANTY	5
2.1 - SAFETY	5
3 – INSTALLATION	6
3.1 - Transport - Handling	6
3.2 - LIFTING THE UNIT	7
3.3 - LAY-OUT AND INSTALLATION REQUIREMENTS	8
3.4 - WATER CONNECTIONS.....	10
3.5 - ELECTRICAL CONNECTIONS	14
3.6 - SOUND LEVELS.....	14
3.7 - CONNECTION OF SPLIT UNITS	14
4 – PRELIMINARY CHECKS	19
4.1 - LIMITS.....	19
4.2 - REFRIGERATION CIRCUIT CHECKS AND RECOMMENDATIONS.....	19
4.3 - INSTALLATION OF EXTERNAL HYDRAULIC COMPONENTS.....	19
4.4 – HYDRAULIC CONNECTIONS AND OPTIONS	20
4.5 - CHECK LIST BEFORE START-UP	21
4.6 MASTER-SLAVE CONFIGURATION (2 units or more) - For MWC™ units only	22
5 – UNIT START-UP	23
5.1 - CHECKS TO BE MADE DURING START UP.....	23
5.2 - WATER FLOW CHECKS.....	24
5.3 - FUNCTIONS AND MAIN REFRIGERANT COMPONENTS.....	25
5.4 - OIL CHARGE	25
5.5 - REFRIGERANT CHARGE	25
6 – OPERATION	26
6.1 – OPERATING LIMITS.....	26
6.2 - UNIT OPERATION: REFRIGERATION CIRCUIT	29
6.3 - UNIT OPERATION: ELECTRICAL AND CONTROL FEATURES.....	32
6.4 – OTHER FEATURES AND OPTIONS.....	37
7 – MAINTENANCE	38
7.1 WEEKLY MAINTENANCE	38
7.2 ANNUAL MAINTENANCE.....	39
7.3 PREVENTIVE MAINTENANCE	39
7.4 CLEANING THE CONDENSER.....	40
7.5 COMPRESSORS / OIL DRAINAGE	40
7.6 CORRECTIVE MAINTENANCE.....	41
7.7 IMPORTANT	41
8 – TROUBLESHOOTING – REPAIRS	42
8.1 LIST OF THE MOST COMMON PROBLEMS	42
8.2 CONTROL DEVICES	47
8.3 REGULAR CHECKS TO BE MADE - CHILLER UNIT ENVIRONMENT	48
8.4 MANUFACTURER’S RECOMMENDED INSPECTIONS	49
9 – CHECK LIST	55
APPENDIX 1: GENERAL REFRIGERATION CIRCUIT DIAGRAM: HYDROLEAN™ COOLING ONLY	58
APPENDIX 2: GENERAL REFRIGERATION CIRCUIT DRIAGRAM: HYDROLEAN™ HEAT PUMP	60
APPENDIX 3: GENERAL REFRIGERATION CIRCUIT DRIAGRAM: HYDROLEAN™ REMOTE CONDENSER. ..	62
APPENDIX 4: GENERAL REFRIGERATION CIRCUIT DRIAGRAM: MWC™	64
APPENDIX 5: GENERAL MECHANICAL DRAWING	66
CERTIFICATES – ISO 9001 : 2000	80
CERTIFICATES – PED	81
CERTIFICATES – DECLARATION OF CE CONFORMITY	82

1 – PREFACE

You must read and be familiar with this operating manual prior to commission the chiller. Please closely follow the instructions.

We would like to stress the importance of training with respect to the correct handling of the chiller. Please consult LENNOX on the options available in this field. It is important that this manual be stored in a permanent location in the vicinity of the chiller.



IMPORTANT GENERAL INSTRUCTION

This manual contains important instructions regarding the commissioning of the chiller. It also includes important instructions to prevent personal injury and damage to the machine during operation. Furthermore, in order to promote fault-free operation of the chiller, maintenance information has been included.

Please do not hesitate to contact one of our employees should you require further information on specific chiller subjects.

Order related documentation will be forwarded under separate cover.

This documentation consists of:

- **CE declaration.**
- **Operating manual for control system.**
- **Installation Operating manual**
- **Wiring diagram.**
- **Unit detail are given on unit nameplate.**

The data published in this manual is based on the most recent information available. It is supplied conditional to later modifications. We reserve the right to modify the construction and/or design of our chillers, at any time, without prior notification or obligation to adapt previous supplies accordingly.



Any work on the Chiller should be carried out by trained and licensed competent technician.

The following risks are present on the unit:

- ***Risk of electrical shock***
- ***Risk of injury from rotating parts***
- ***Risk of injury from sharp edges and heavy weight***
- ***Risk of injury from high pressure gas***
- ***Risk of injury from high and low temperatures components.***

It is expected that all works on equipment be carried out in accordance with all local standards and norms. It is expected that all works are carried out with good working practices.

All units are compliant with the following norms and standards:

- . DI 97/23/CE Pressure Equipment Directive.
- . DI 98/37/CE Machinery Directive.
- . DI 73/23/CE Low Voltage Directive.
- . DI 89/336/CE Electro Magnetic Compatibility Directive
- . EN 378-2 Safety and Environmental Directive.
- . The European Restriction of the Use of Certain Hazardous Substances (RoHS)

IMPORTANT NOTICE***All work on the unit must be carried out by a qualified and authorised employee.***

Non-compliance with the following instructions may result in injury or serious accidents.

Work on the unit:

- . The unit shall be isolated from the electrical supply by disconnection and locking using the main isolating switch.
- . Workers shall wear the appropriate personal protective equipment (helmet, gloves, glasses, etc.).

Work on the electrical system:

- . Work on electric components shall be performed with the power off (see below) by employees having valid electrical qualification and authorisation.

Work on the refrigerating circuit(s):

- . Monitoring of the pressures, draining and filling of the system under pressure shall be carried out using connections provided for this purpose and suitable equipment.
- . To prevent the risk of explosion due to spraying of coolant and oil, the relevant circuit shall be drained and at zero pressure before any disassembly or unbrazing of the refrigerating parts takes place.
- . There is a residual risk of pressure build-up by degassing the oil or by heating the exchangers after the circuit has been drained. Zero pressure shall be maintained by venting the drain connection to the atmosphere on the low pressure side.
- . The brazing shall be carried out by a qualified brazer. The brazing shall comply with the standard NF EN1044 (Minimum 30% silver).

Replacing components:

- . In order to maintain CE marking compliance, replacement of components shall be carried out using spare parts, or using parts approved by LENNOX.
- . Only the coolant shown on the manufacturer's nameplate shall be used, to the exclusion of all other products (mix of coolants, hydrocarbons, etc.).

CAUTION:

In the event of fire, refrigerating circuits can cause an explosion and spray coolant gas and oil.

2 – WARRANTY

The warranty of the chillers is subject to the warranty definitions as agreed upon in the order. It is expected that the design and installation of the unit utilises good working practices.

The warranty will be legally null and void if:

- ***Service and maintenance have not been executed in accordance with the regulations; repairs have not been carried out by LENNOX personnel or have been implemented without prior written permission by LENNOX.***
- ***Modifications have been made to the equipment without prior written permission by LENNOX.***
- ***Settings and protections have been modified without prior written permission by LENNOX.***
- ***Non-original or other than the prescribed refrigerants or lubricants are used.***
- ***The equipment has not been installed and/or connected in accordance with the installation instructions.***
- ***The equipment is being used improperly, incorrectly, negligently or not in accordance with its nature and/or purpose.***
- ***A flow protection device is not fitted.***

In these circumstances LENNOX is indemnified from any product liability claims from third parties.

In the event of a warranty claim the machine serial number and LENNOX order number must be quoted.

2.1 - SAFETY

The safety information contained in this manual is provided as a guide for the safe handling of this installation. LENNOX does not vouch for the completeness of this information and can therefore not accept liability for any possible omissions.

In the chillers, heat is being transported by a pressurised refrigerant, with changes in pressure and temperature. The protection of operating and maintenance personnel was central in the design of the chiller. Safety features have been included to prevent excessive pressure in the system. Sheet metal parts have been fitted to prevent inadvertent contact with (hot) pipes.

The electrical control panel is completely touch-proof. This excludes some parts operating at a safe voltage (< 50 Volt). The service panels can only be opened using tools.

Notwithstanding that the chillers are equipped with extensive safety and protection features, the utmost care and attention is needed when carrying out operations on the machine. Furthermore, ear protection should be worn when working on or in the vicinity of the chillers. Operations on the cooling circuit or electrical equipment should be carried out by authorised personnel.

2.1.1 - Safety Definition

The water cooled chillers meet the following safety definitions:

- Pr-EN-378-1.
- EU Directive 89/392/EG (“Machine Directive”).
- EN-60204-1.
- “EMC Directive”.
- Pressure Equipment Directive 97/23/CE.

And is provided with CE markings (on the condition that the necessary options are present) (for further information see II-A declaration).

2.1.2 - Warning labels

The chiller is marked with the following warning labels to alert to potential hazards (on or near the potentially hazardous part).



High temperatures



Electrical Voltage



Rotating parts



Sharp parts

Check regularly that the warning labels are still in the correct positions on the machine and replace them if necessary.

3 – INSTALLATION

3.1 - Transport - Handling

3.1.1 - Controls and delivery checks

After the unit has been received, when it is ready to be installed or reinstalled, and before it is started up, it must be inspected for damage.

On receipt of a new equipment please check the following points. It is the customer's responsibility to ensure that the products are in good working order (fill the check list page 50):

- The exterior has not been damaged in any way.
- The lifting and handling equipment are suitable for the equipment and comply with the specifications of the handling instructions enclosed here-in.
- Accessories ordered for on site installation have been delivered and are in good working order.
- If the unit is delivered with its operating charge of refrigerant, that there has been no leakage (use an electronic detector).
- The equipment supplied corresponds to the order and matches the delivery note.

If the product is damaged, exact details must be confirmed in writing by registered post to the shipping company within 48 hours of delivery (working days).

A copy of the letter must be addressed to LENNOX and the supplier or distributor for information purposes. Failure to comply will invalidate any claim against the shipping company. Please be reminded that LENNOX is not responsible for off-loading and positioning.

3.1.1.1: Unit Nameplate

The rating plate provides a complete reference for the model and ensures that the unit corresponds to the model ordered. It states the electrical power consumption of the unit on start-up, its rated power and its supply voltage.

The supply voltage must not deviate beyond +10/-10 %.

The start-up power is the maximum value likely to be achieved for the specified operational voltage. The customer must have a suitable electrical supply. It is therefore important to check whether the supply voltage stated on the unit's rating plate is compatible with that of the mains electrical supply. The rating plate also states the year of manufacture as well as the type of refrigerant used and the required charge for each compressor circuit.

LENNOX USINE LYON Z.I. LES MEURIERES Tel. 04 72 23 20 20 69780 MIONS - FRANCE	
Type / Unit type	SWR 135 DSK RE
N° Serie / Serial N.R.	130229/01
Annee / Year	07/2005
Refrigerant / Fluide	R407C
Nombre de circuits / Circuits N.R.	2
Kg/Circuit	C1 C2 C3 C4
Pression Max. service HP Max. operating pressure HP	27 bar
Pression Max. service BP Max. operating pressure BP	15 bar
Puissance frigo nominale Capacity	162 Kw
Alimentation Elec. principale Elec. supply	400/3/50 V/ph/Hz
Alimentation Elec. auxiliaire Elec. auxiliary	24/1/50 V/ph/Hz
Valeur alim. principale/auxiliaire Elec. value supply/auxiliary	KVA
Temp. Air ambiant Maxi Air ambiant temp. Maxi	+45 °C
Poids total Unit weight	1034 Kg
Type compresseur Compressor type	ZR/16-ZR310
Pression d'épreuve HP Test pressure HP	32 bar
Pression d'épreuve BP Test pressure BP	20 bar
Pression Max. service HP Max. operating pressure HP	27 bar
Pression Max. service BP Max. operating pressure BP	15 bar
CE 0062	

LENNOX Factory Mions Z.I. LES MEURIERES 69780 MIONS FRANCE		CE 0062					
Unit type : MRC 570D NM1M							
Serial NR : 146054/01							
	Voltage (V)	Phase (Ph)	Frequency (Hz)	Current (A)			
Elec supply	400	3	50	Nominal	Starting		
Elec auxiliary	24	1	50	417	668		
	Min		Max				
	LP	HP	LP	HP			
Pressure (PS) (bar)	-1	-1	29.5	42			
Temperature (TS) (°C)	-20	-20	50	110			
Storage Temperature (°C)	-30		50				
LP : Low Pressure side / HP : High Pressure side							
Capacities (kW)		Ref charge (kg)		Dates			
Cooling	Heating	C1	C2	C3	C4	Prod.	Test
494	0	0	0	0	0	2011	16/03/2011
Fluid		Fluid group		Weight (kg)			
R 410 A		2		1870			
This product is used for Air Conditioning. Contains fluorinated greenhouse gases covered by the Kyoto protocol. Hermetically sealed.							

3.1.2 - Storage

When units are delivered on site they are not always required immediately and are sometimes put into storage. In the event of medium to long-term storage, we recommend the following procedures:

- Ensure that there is no water in the hydraulic systems.
- Keep the heat exchanger covers in position.
- Keep protective plastic film in position.
- Ensure the electrical panels are closed.
- Keep all items and options supplied in a dry and clean place for future assembly before using the equipment.

It is strongly recommended to store units in a dry, sheltered place (in particular for units that will be installed indoor).

3.2 - LIFTING THE UNIT

3.2.1 - Safety instructions

Installation, start up and adjustment of this equipment can be dangerous if certain system specific factors are ignored, such as operating pressures, electrical components, locations (roofs, terraces and other structures located well above ground level).

Only highly qualified contractors and technicians with sound knowledge of this type of equipment, are authorised to install, start up and service it.

During any service operations, observe the recommendations given on labels or instructions sent with the equipment, as well as any other applicable safety procedures.

- Follow all safety rules and regulations
- Wear protective glasses and work gloves
- Handle heavy or bulky equipment carefully during lifting and moving operations, and when setting it on the ground.

CAUTION: BEFORE EACH SERVICE OPERATION MAKE SURE THAT THE UNIT POWER SUPPLY IS PROPERLY ISOLATED AND LOCKED OUT.

NOTE: SOME UNITS MAY HAVE A SEPARATE 230V CONTROL SUPPLY THAT REQUIRES SEPARATE ISOLATION. PLEASE CHECK THE WIRING DIAGRAM.

3.2.2 - Handling schemes

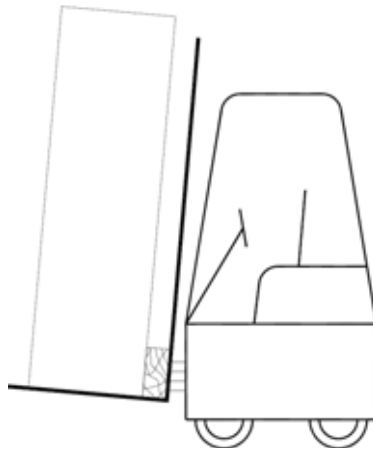

3.2.3 - Handling

Handling operations must be carried out by qualified personnel. Comply strictly with the lifting instructions as well as with any other applicable safety procedures. Wear protective glasses and work gloves. Unit handling operations must be carried out carefully to avoid jolting the frame, the panels, the electrical box, etc....

NOTE:

The machine is also wrapped in packing foil. It is recommended to leave this protection in place during any transport and lifting operations, and not to remove the plastic plates until commissioning (take care that the protecting foil wrapping is not blown away!).

NOTE:

Rubber anti-vibrations mountings (AVM) & factory accessories are to be found in the control panel or in an extra box for shipping. If the unit is mounted on anti-vibration mountings, these should be fitted to the unit before final positioning.

CAUTION: IN CASE OF REINSTALLATION OF THE UNIT, MAKE SURE THAT THE UNIT POWER SUPPLY IS PROPERLY ISOLATED AND LOCKED OUT.

NOTE: SOME UNITS MAY HAVE A SEPARATE 230V CONTROL SUPPLY THAT REQUIRES SEPARATE ISOLATION. PLEASE CHECK THE WIRING DIAGRAM.

WARNING: HYDROLEAN™ Size 120,135 and 165 are very narrow and high: there is a risk of the unit tipping over when being handled with a fork lift.

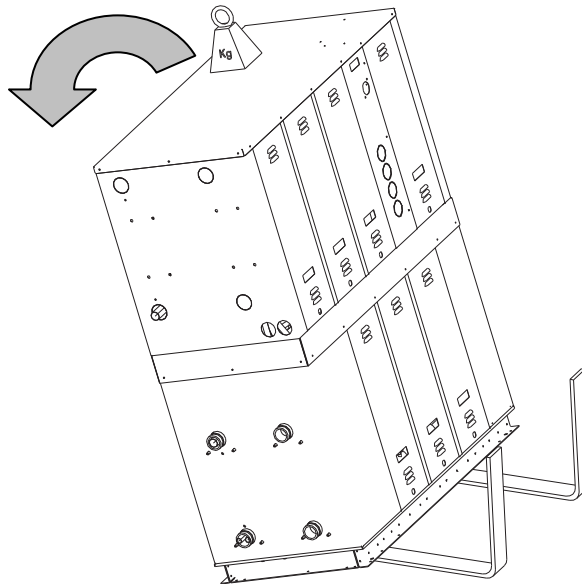
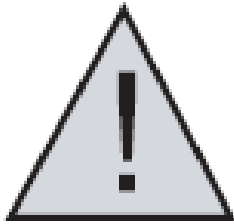

3.3 - LAY-OUT AND INSTALLATION REQUIREMENTS

The following preparations are important for the installation of the chiller:

- Water -cooled chillers such as HYDROLEAN™ or MCW are designed for indoor installation. Please consult LENNOX prior to implementing other types of installation.
- The ground beneath the unit must be flat, level and of sufficient strength to support the weight of the unit with its full liquid charge, and the occasional presence of the usual service equipment.
- In locations exposed to frost, the supporting surface, if the unit is installed on the ground, must be built on concrete stakes extending downwards beyond the normal depth of frost. It is always advisable to build a supporting surface detached from the general building structure to avoid transmission of vibrations.
- On normal applications, unit rigidity and point load positions enable installation to minimise vibrations. Vibration isolators may be used by contractors on installations requiring particularly low vibration levels.



Use of vibration isolators MUST be accompanied by installation of flexible connections in the unit water piping. Vibration isolators must also be secured to the unit BEFORE being attached to the ground. Selection of vibration absorbing isolator capacity is not LENNOX's responsibility.

- The unit must be bolted to the vibration isolators and the latter solidly secured into the concrete slab. Check that vibration isolator contact surfaces fit flush to the floor. If necessary, use spacers or re-surface the flooring, but in all events, make sure that the isolators seat flatly on the supporting surface.
- It is essential that the units be installed with sufficient free space around them to provide easy access to all unit components for servicing and maintenance.

It is important that units must be levelled. Failure to install unit correctly will void warranty.

CLEARANCES DRAWINGS

For more details, please consult our Application Guides or the drawings supplied with the unit.

HYDROLEAN™ 020 to 040

HYDROLEAN™ 050 to 100

HYDROLEAN™ 120 to 165

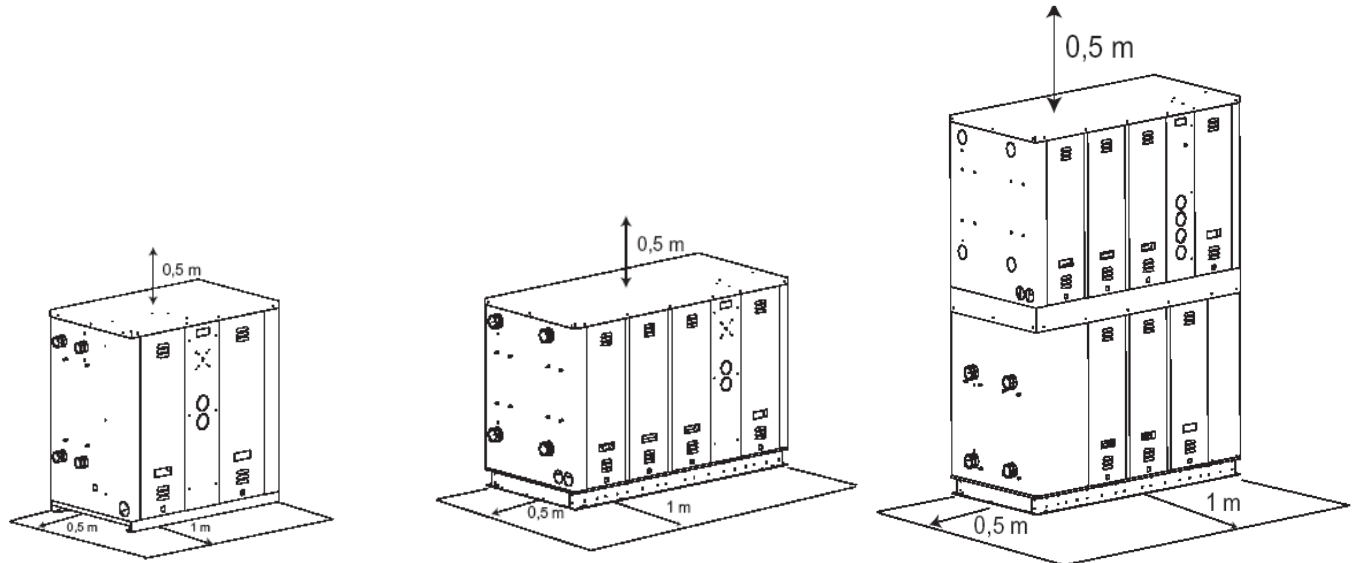

For any chiller, a minimum distance of 1 meter is required for the good opening and servicing of the electrical box. In case of a compressor replacement, 1m is also reasonable to remove it.

MWC 450 - 510 - 570 - 650 - 720

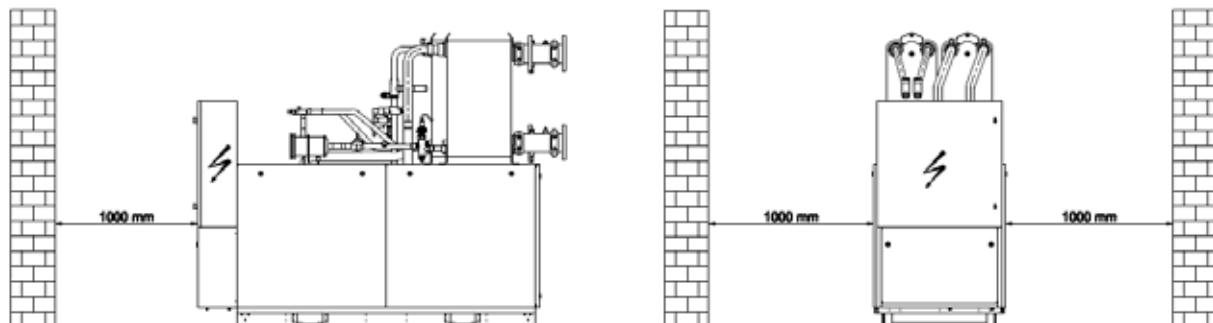
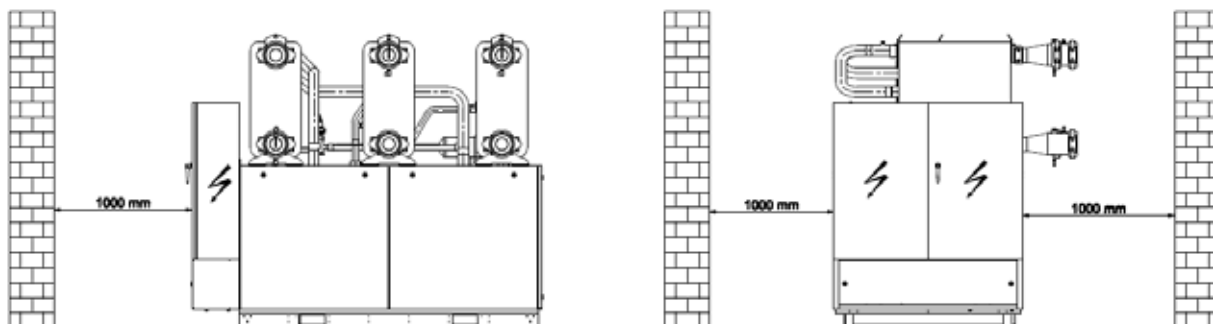

MWC 180 - 230 - 280 - 330 - 380

3.4 - WATER CONNECTIONS

3.4.1 - Water connections - Evaporator/Condenser

Before the system start-up check that the water circuits are connected to the right heat exchangers (e.g. no reversal between evaporator and condenser or between water in and outlets). The water circulating pump will be preferably installed upstream so that the evaporator/condenser will be subjected to positive pressure. Entering and leaving water connections are indicated on the certified drawing sent with the unit or shown in the sales brochure.

For shell and tube heat exchangers, a drainage plug is located at the base of the evaporator. A drainage pipe may be connected to this to enable drainage of evaporator water for service operations or for seasonal shut down.

The use of a water filter in the water circuit upstream of the heat exchanger is mandatory. These filters must remove all particles with a diameter greater than 1 mm, and must be positioned within 1 meter of the inlet of the exchanger. They may be supplied as an option by the manufacturer.



LACK OF FILTER AT THE INLET OF A PLATE HEAT EXCHANGER WILL MAKE WARRANTY VOID.

Hydraulic drawings in Appendices, or supplied with the unit.

Below some other important items about the water circuit:

- .The water pipes must not transmit any radial or axial force to the heat exchangers nor any vibration. (Use flexible connections to reduce the transmission of vibrations.)
- .Manual or automatic air bleeders must be installed at all high points in the circuit(s).
- .Drain connections must be installed at all low points to allow the whole circuit to be drained.
- .An expansion device must be installed to maintain pressure in the circuit(s) as well as a safety device

3.4.2 - Water analysis

The heat exchangers are made of copper brazed AISI304 stainless steel plates.

To avoid or at least to limit corrosion of the heat exchangers, to begin with, the water should be analyzed and the water characteristics should comply with the following points:

- .electrical conductivity > 50 μ S/cm
- .pH 7.5-9
- .Sulphate, SO₄²⁻ < 70ppm
- .[HCO₃³⁻]/[SO₄²⁻] > 1
- .Ammonia, NH₃ < 0.5ppm
- .Free CO₂ < 10ppm
- .Cl⁻ < 50ppm
- .Fe³⁺ < 0.5ppm

The actual corrosion however is a very complex process influenced by many factors in combination. The resistance guide below is an attempt of give a picture of the corrosion resistance of AISI 316 stainless steel and pure copper in water, with regards to a number of important chemical factors. The table below is therefore a considerable simplification and should not be overvalued.

Explanations:

- + : Good resistance under normal conditions
- 0 : Corrosion problems can occur especially when the factors are valued as 0
- : Use is not recommended.

WATER CONTAINING	CONCENTRATION mg/l ó ppm	AISI 316	COPPER
Alcalinity (HCNO ₃)	<70	+	0
	70-300	+	+
	>300	+	0
Sulfate (SO ₄ ²⁻)	<70	+	+
	70-300	+	-
	>300	0	-
HCO ₃ ⁻ / SO ₄ ²⁻	>1.0	+	+
	<1.0	+	-
Electrical conductivity	<10µS/cm	+	0
	10-500µS/cm	+	+
	>500µS/cm	+	0
pH	<6.0	0	0
	6.0-7.5	0/+	0
	7.5-9.0	+	+
	>9.0	+	0
Amonium (NH ₃)	<2	+	+
	2-20	+	0
	>20	+	-
Chloroides (Cl ⁻)	<50	+	+
	>50	0	0
Free chlorine (Cl ₂)	<1	+	+
	1-5	+	0
	>5	0/+	-
Hydrogen sulfide (H ₂ S)	<0.05	+	+
	>0.05	+	-
Free(aggressive) Carbon Dioxide (CO ₂)	<5	+	+
	5-20	+	0
	>20	+	-
Total hardness (°dH)	4.0-8.5	+	+
Nitrate (NO ₃)	<100	+	+
	>100	+	0
Iron (Fe)	<0.2	+	+
	>0.2	+	0
Aluminium (Al)	<0.2	+	+
	>0.2	+	0
Manganese (Mn)	<0.1	+	+
	>0.1	+	0

Caution: dissolved oxygen: any sudden change in water oxygenation conditions must be avoided. The disturbance of the oxygenation conditions encourages destabilisation of copper hydroxides and enlargement of particles.

The water circuit installed must include all items necessary for treatment of the water: Filters, additives, intermediate exchangers, bleed valves, vents, isolating valves, depending on the results of the analysis.



For these reasons, we do not advise operation of the units with open loops, or operation with untreated ground water (composition may change).

Use of untreated or improperly treated water can cause deposits of scale, algae and sludge or cause corrosion and erosion. It is advisable to call in a qualified water treatment specialist to determine what kind of

treatment will be necessary. The manufacturer cannot accept liability for damage caused by the use of untreated or improperly treated water, salt water or brine.

If the water circuit must be emptied for longer than one month, the complete circuit must be placed under nitrogen charge to avoid any risk of corrosion by differential aeration.

3.4.3 - Antifreeze protection

3.4.3.1: Use glycol/water solution

ADDITION OF GLYCOL IS THE ONLY EFFICIENT WAY TO PROTECT AGAINST FREEZING



The glycol/water solution must be sufficiently concentrated to ensure proper protection and prevent formation of ice at the lowest outdoor air temperatures expected on an installation. Take precautions when using non-passivated MEG antifreeze solutions (Mono Ethylene Glycol or MPG Mono Propylene Glycol). Corrosion can occur with these antifreeze solutions with oxygen.

3.4.3.2: Drain the installation



It is important to make sure that manual or automatic air bleeders are installed at all the high points of the water circuit. To enable drainage of the circuit, make sure that drain cocks are installed at all the low points of the circuit. To drain the circuit, the drain cocks must be opened and an air inlet ensured. Note: air bleeders are not designed to admit air.

FREEZING OF A HEAT EXCHANGER DUE TO COLD WEATHER CONDITIONS IS NOT COVERED BY LENNOX WARRANTY.

3.4.4 - Electrolytic corrosion



We would like to draw your attention to the problems of corrosion due to electrolytic corrosion caused by an imbalance between earthing points.

AN EXCHANGER THAT IS PUNCTURED BY ELECTROLYTIC CORROSION IS NOT COVERED BY THE UNIT WARRANTY

3.4.5 - Minimum water capacity

3.4.5.1: HYDROLEAN™



The minimum volume of the chilled water circuit must be calculated with the formula here under. If necessary, install a buffer tank. Proper operation of regulating and safety devices can only be ensured if the volume of water is sufficient. The theoretical volume of the water loop for a proper air conditioning operation can be calculated using the formula hereafter:

- Q → Cooling capacity of the chiller in kW
- N → Number of capacity stage of the chiller
- Dt → Water temperature Delta T.

$$V_t = 72 \times Q / (n \times dt) \text{ litres}$$

Example, for a chiller with 100kW, water conditions 12°C/7°C and 4 capacity stages, the minimum volume is: $V_t = 72 \times 100 / (5 \times 4) = 360 \text{ L}$

This formula will give the minimum water capacity of the installation that will ensure a temperature rise of the water loop of (dt/n)°C during anti short cycle of compressors.

This formula is only applicable for air-conditioning installation and must not be used for process cooling where temperature stability is required.

3.4.5.2: MWC™

Thanks to multi step capacity control and smart anti-short compressor cycling, MWC™ can work with minimum water loop volume as defined here below. This can eliminate the need for a buffer tank in most of air-conditioning applications (e.g. MWC™ application with fan-coil units). :

Whatever the system, the minimum water content for the complete installation depends on the application and is given by the following formula

$$V_{\text{mini}} = 86 \times Q / (n \times dt)$$

Where

- : V is the minimum water content of the installation
- Q is the cooling capacity of the chiller
- Nstage is the number of control steps available in the unit
- Dt is the maximum acceptable temperature rise (Dt = 6°C for an air conditioning application)

For MWC/MRC Chiller

Unit Size	Number of stages	Minimum Water volume (L)
180	4	645
230	5	659
280	6	669
330	5	946
380	4	1362
450	6	1075
510	6	1218
570	6	1362
650	6	1553
720	6	1720

Note : The volume of the condenser water loop has no impact on the chiller operation. In heat pump operation (with hot water set point control option), the minimum volume of the condenser water loop must be calculated based on the heating capacity using the same formula.

Glycol correction factors:

Minimum ambient temperature or water outlet temperature	Ethylene glycol %	pressure drop	water flow	CAPACITIES	
				Cooling	Heating
+5 --> 0°C	10%	1,05	1,02	0,99	0,994
0 --> -5°C	20%	1,1	1,05	0,98	0,993
+5 --> -10°C	30%	1,15	1,08	0,97	0,99
-10 --> -15°C	35%	1,18	1,1	0,96	0,987

example: 20% glycol instead of water -->: water flow x 1,05; Pressure drop x 1,1; Cooling capacity x 0,98

3.4.6 - Flow switch



A flow switch must be installed on the evaporator water inlet or outlet, so as to enable detection of water flow through the heat exchanger before the unit is started up. This will protect the compressors against any eventual liquid slugging during the starting phase and prevent accidental ice formation in the evaporator, if the flow of water is interrupted.

Flow switches are available as standard on certain units and always as option. The normally open contact of the flow switch should be connected to the terminals provided to that effect in the unit electrical box. (See the wiring diagram supplied with the unit). The normally closed contact can be used as an indication of a lack of flow condition.

Warranty is void if a flow detection device is not fitted and connected to the LENNOX control panel.

3.5 - ELECTRICAL CONNECTIONS

First of all, make sure that power supplies from the building to the place where the unit is installed are properly established and that wire gauges are in keeping with the start up and running currents. Check tightness of all electrical connections. You **MUST** make absolutely certain that the power supplies applied to the power and control circuits are those for which the electrical panel was manufactured.

A main isolator switch must be inserted between the end of the power supply cable and the unit to enable total isolation of the latter when necessary. Chillers are usually supplied with a main isolator switch. If not it is available as an option.

WARNING



Wiring must conform to applicable regulations. The type and location of fused isolators must also conform to regulations. For the sake of safety, install them where they can be seen and in easy reach of the unit. Units must have full earthing continuity.

IMPORTANT



Operation of a unit with the wrong power supply or with excessive phase imbalance constitutes abuse and is not covered by the LENNOX warranty. If phase imbalance exceeds 2 % for voltage and 1 % for current, contact your local electricity company immediately before powering up the unit.

3.6 - SOUND LEVELS

Liquid chillers can be a significant source of noise in refrigeration and air conditioning systems.

Account is taken of technical constraints, both in design and manufacturing, sound levels cannot be improved much further than specified.

Sound levels must therefore be accepted for what they are, and the area surrounding the chillers should be treated as necessary. The quality of installation can either improve or decrease initial sound characteristics: it may be necessary to provide further treatment such as sound-proofing or installation of screens around units installed externally.

The choice of the location for the installation can be of great importance: reflection, absorption, transmission of vibrations.

The type of unit support is also very important: inertia of the room and the structure of the walling, interfere with the installation and its behaviour.

Before taking any other steps, first determine whether the sound level is compatible or not with the environment, what it is perfectly justifiable and that these measures envisaged will not cause unreasonable cost.

Determine what level of sound proofing is necessary on the equipment, the installation (silencer, vibration isolators, and screens) and on the building (reinforcement of flooring, false ceilings, and wall coverings).

It may be necessary to contact an engineering office that specialises in sound abatement.

3.7 - CONNECTION OF SPLIT UNITS

Connections between the unit and the condenser must be made by a qualified refrigeration engineer and require several important precautions.

Especially, the shape and dimensions of the hot gas lines must be carefully designed to ensure proper oil return (Oil is carried off by entrainment) in all cases and prevent liquid from returning into the compressor when the compressor is stopped. All rising discharge lines must have oil traps installed as on the drawing below. Above 6m height difference, install additional oil traps.

If the unit is designed to run at reduced capacity, the pipe sizes must be calculated so that gas velocity is also sufficiently high when the unit is operating at capacity reduction. So double discharge lines must be installed with the best diameter size selections for about 2/3rd of the total capacity for the bigger line and about 1/3rd of the total capacity for the smaller line. Use enough pipe line supports and design the lines to avoid hydraulic rams. The total pressure drop in the liquid line must not result in a change in phase. The total liquid line pressure drop estimate must include those generated by the filter drier, moisture sight glass and the solenoid valve. Select remote condensers with at least 3°C subcooling.

Non application of these design precautions will cancel the compressor warranty.

We recommend following ASHRAE recommendations.

3.7.1 - Liquid line sizing

Determine the size of liquid lines using:

- 1) Operating conditions at full load.
- 2) Maximum pressure drop of 100 kPa
- 3) Liquid velocity under 2 m/s (to avoid liquid slugging).

4) For liquid risers, make sure that liquid sub cooling is sufficient to counteract the loss of static pressure and prevent gas flashing.

For MWC™ units:

If the refrigerant in the liquid line flashes to a gas because the pressure drops too low or because of an increase in elevation, then the refrigeration system will not operate correctly. Liquid sub-cooling is the only method that prevents refrigerant flashing to gas due to pressure drops in the line. Pressure drops corresponding to 1.5°C saturated temperature must not be exceeded. Special attention must be paid to the liquid line sizing when the expansion valve is positioned higher than the condenser: The total pressure drop in the liquid line is the sum of the friction loss, plus the weight ($g \cdot p \cdot \Delta h$) of the liquid refrigerant column. An additional subcooler may have to be installed to prevent a phase change in the liquid line if the total pressure drop is too high. At 45°C, the volume mass of refrigerant R-410A in the liquid phase is approximately 940 kg/m³. A pressure of 1 bar corresponds to a liquid head of: $100\,000 / (940 \times 9.81) = 10.8$ m. **The maximum recommended speed in the liquid lines is 1.5m/s** to avoid liquid hammering that may occur when the solenoid valve closes.

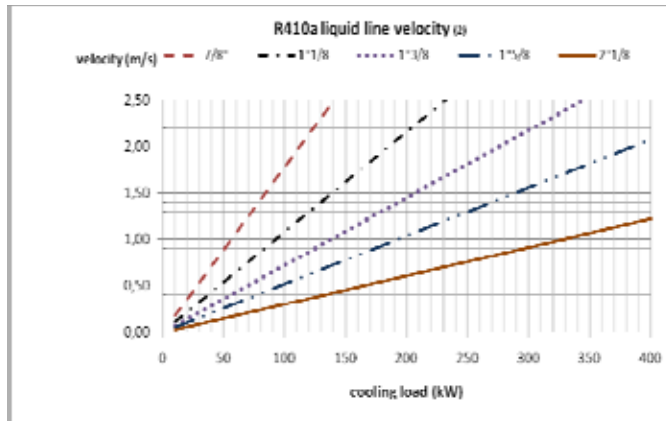

(2): at 45°C with 5°C subcooling and 8°C suction temperature; for other conditions, use the correction factor table.

3.7.2 - Discharge lines and suction lines

Calculate these to obtain a gas velocity in vertical sections that enables compressor oil migration and steady return to the compressor (tables C and D).

Determine the dimensions of vertical lines using the following tables.

Horizontal lines may be bigger in order to compensate pressure drop in vertical lines.

The total pressure drop in the piping has to be lower or equal to 1°C at saturation pressure on the suction side.

For MWC™ units:

The pressure drop at the compressor discharge (pipes linking the compressor outlet with the condenser inlet) must be as small as possible to limit system performance losses (At 50°C condensing temperature, with 1.5°C equivalent pressure drop (1.07bar), the compressor power input increases by 3% and the cooling capacity decreases by 2.5%). Maximum refrigerant speed: 15m/s; **minimum speed on horizontal lines: 3.5m/s; minimum speed on rising lines: 8m/s.**

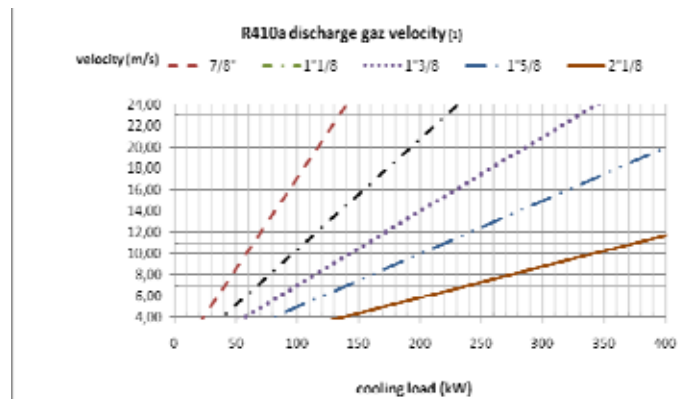

(1): at 50°C condensing temperature and 8°C suction temperature; for other conditions, use the correction factor table.

Units with remote condenser

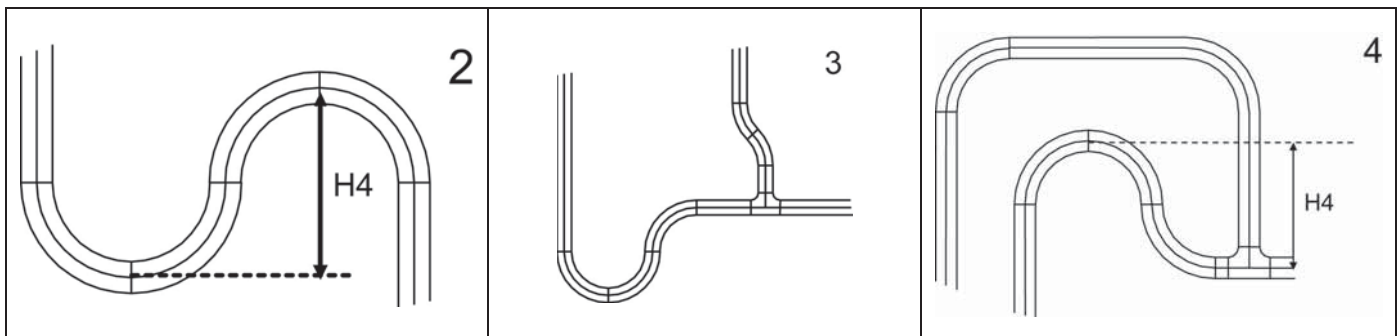
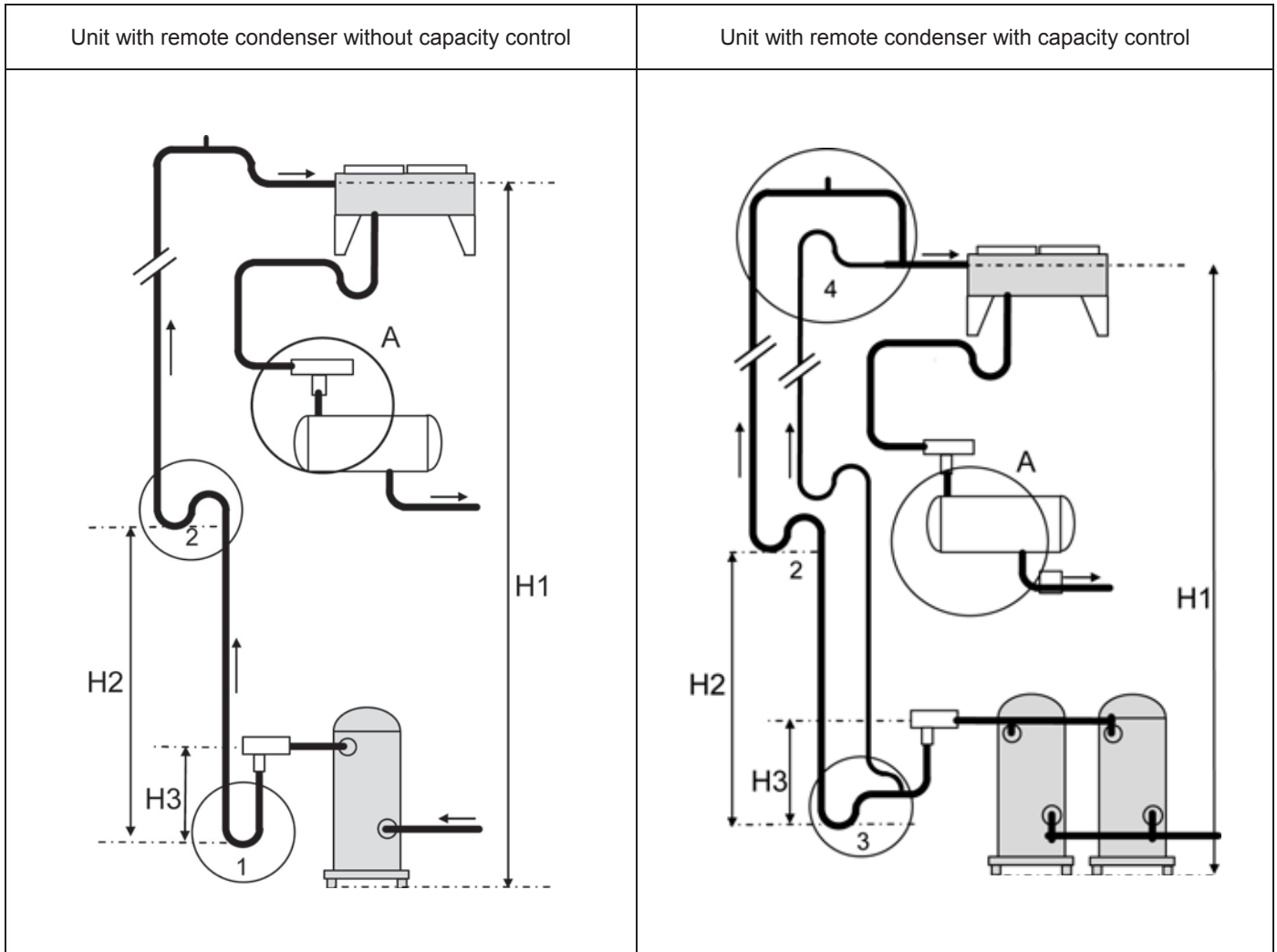

H1: 15 m. maxi
H2: 5 m. maxi
H3: 0,3 m. maxi
H4: 0,15 m. maxi

1 - Lower trap with single tube
2 - Clode coupled trap
3 - Lower trap with double tubes
4 - Higher trap with double tubes

WARNING: The liquid level between the condenser and the check valve A must compensate the check valve pressure drop

For HYDROLEAN™ units:

Minimum refrigeration capacity in kW for oil entrainments up Suction risers													
refrigerant R407C													
		Tubing Nominal OD, mm											
saturated temp °C	Suction gas temp °C	12	15	18	22	28	35	42	54	67	79	105	130
-5	0	0,39	0,71	1,20	2,04	3,88	6,88	11,11	21,31	36,85	55,86	115,24	199,30
	10	0,37	0,68	1,14	1,94	3,68	6,53	10,54	20,20	34,94	52,95	109,25	189,14
5	10	0,47	0,86	1,45	2,47	4,69	8,33	13,44	25,77	44,58	67,56	139,39	241,30
	20	0,44	0,81	1,36	2,31	4,39	7,79	12,58	24,13	41,73	63,25	130,49	225,90

Minimum refrigeration capacity in kW for oil entrainments up HOT-Gas risers													
refrigerant R407C													
		Tubing Nominal OD, mm											
saturated discharge temp °C	Discharge gas temp °C	12	15	18	22	28	35	42	54	67	79	105	130
30	70	0,60	1,09	1,84	3,13	5,95	10,55	17,03	32,65	56,47	85,59	176,59	305,70
	80	0,58	1,06	1,79	3,04	5,78	10,25	16,55	31,74	54,90	83,21	171,67	297,19
	90	0,57	1,04	1,74	2,96	5,64	10,00	16,14	30,95	53,53	81,13	167,39	289,77
40	80	0,62	1,13	1,90	3,24	6,16	10,93	17,65	33,85	58,55	88,73	183,07	316,92
	90	0,60	1,10	1,85	3,16	6,00	10,65	17,19	32,96	47,01	86,40	178,26	308,60
	100	0,58	1,07	1,80	3,07	5,83	10,34	16,70	32,02	55,38	83,94	173,17	299,79
50	90	0,63	1,16	1,94	3,31	6,29	11,16	18,02	34,55	59,77	90,58	186,88	323,52
	100	0,61	1,12	1,88	3,21	6,10	10,82	17,47	33,50	57,95	87,83	181,21	313,70
	110	0,60	1,09	1,83	3,13	5,94	10,54	17,02	32,63	56,44	85,53	176,47	305,49

Correction tables for MWC™ units:

Discharge gas velocity correction factors		condensing temperature °C							
		25	30	35	40	45	50	55	60
suction temperature °C	13	1,37	1,25	1,15	1,07	1,01	0,96	0,93	0,92
	8	1,41	1,30	1,20	1,11	1,05	1,00	0,97	0,96
	3	1,47	1,34	1,24	1,16	1,09	1,04	1,01	1,00

Liquid line velocity correction factors		liquid line temperature °C, 5°C subcooled							
		20	25	30	35	40	45	50	55
suction temperature °C	13	0,67	0,72	0,77	0,83	0,90	0,99	1,10	1,23
	8	0,67	0,72	0,78	0,84	0,91	1,00	1,11	1,24
	3	0,68	0,73	0,78	0,85	0,92	1,01	1,12	1,26

3.7.3 - Mechanical isolation of refrigerant lines

Isolate refrigerant lines from the building to prevent the vibrations normally generated by the lines to the building structure. Avoid bypassing the isolation system on the unit by securing refrigerant lines or electrical conduits too tightly. Any vibrations will be transmitted to the building by rigid piping. Lack of vibration isolation on refrigerant pipework will lead to early failure of copper pipe and loss of gas.

3.7.4 - Pressure test

To avoid formation of copper oxide during brazing operations, blow a little dry nitrogen through the pipes. Piping must be made with tubing that is perfectly clean, plugged during storage and between connections operations.

During these operations, observe the following precautions:

- 1) Do not work in a confined atmosphere, refrigerant fluid can cause asphyxiation. Make sure there is sufficient ventilation.
- 2) Do not use oxygen or acetylene instead of refrigerant fluid and nitrogen for leak testing : this could cause a violent explosion.
- 3) Always use a regulator valve, isolating valves and a pressure gauge to control test pressure in the system. Excessive pressure can cause lines to burst damage to the unit and/or cause an explosion with severe personal injury.

Ensure conduct liquid line and gas line pressure tests are in conformity with applicable legislation. Before starting up a unit on a receiver, the piping and the condenser must be dehydrated. Dehydration should be carried out using a double stage vacuum pump, capable of drawing 600Pa absolute pressure vacuum.

Best results are obtained with a vacuum down to 100 Pa.

To get down to this level at normal temperatures, i.e. 15 °C, it is often necessary to leave the pump running for 10 to 20 hours. The duration of pump operation is not a factor of efficiency. The pressure level must be checked before the unit is put into service.

3.7.5 - Refrigerant charge

For MWC™ units:

Chillers with R407C must be filled in the liquid phase. Never charge a machine operating on R407C in the vapour phase (vapour): the composition of the mixture could be modified. In liquid phase, connect either to a liquid isolating valve, or to the quick-connector on the liquid line at the valve outlet.

For unit using R22, the charging may be done in vapour phase in that case; connection will be made to the suction valve.

For HYDROLEAN™ units:

Self-contained units have a complete refrigerant charge at the time they are shipped. Split units need in most cases an additional charge. This charge may need to be topped up when the unit is installed or at other times during the service life of the unit. Chillers with R410a must be filled in the liquid phase. In liquid phase, connect either to a liquid isolating valve, or to the quick-connector (Shrader) on the liquid line at the valve outlet.

Note for all units:

Split units are supplied with a refrigerant or nitrogen holding charge. Before pulling down the vacuum for dehydration, completely purge the unit. Every time refrigerant is added, check the state of the charge with the sight glass if provided and also by the amount of liquid sub cooling at the condenser outlet according to the system design value. In all cases, do not top up the charge until the unit reaches a stable state of operation. Don't overcharge a system, this can adversely affect operation.

Overcharging causes:

- Excessive discharge pressure,
- A risk of damage for the compressor,
- Excessive power consumption.

3.7.6 - Oil charge

All units are delivered with a complete oil charge, and there is no need to add any oil before start up or afterwards. When a compressor is replaced and in the case of split units, it may be necessary, due to the length of piping installed, to add a certain amount of oil (RL32-3MAF or for refill MOBIL EAL Arctic 22CC for MWC™ units, and please refer to the following oil tables for HYDROLEAN™ units). Overcharging with oil can cause serious problems on an installation, particularly for the compressors.

3.7.7 PED CATEGORY

The PED Category of the entire MRC (and MWC) range is Category II.

4 – PRELIMINARY CHECKS



IMPORTANT

- Start up and commissioning must be conducted by LENNOX authorised engineer.
- Never shut off power to the crankcase heaters except for long service operations or seasonal shutdown

Check that all drain and purge plugs are in place and well tightened prior to fill the installation with water.

4.1 - LIMITS

Prior to any operation, please check the operation limits of the unit given in the «APPENDIX» at the end of the IOM, These tables will give you all necessary information concerning the operating envelop of the unit. Please consult the «Risk analysis and hazardous situations according to 97/123 directive» given in the «APPENDIX» at the end of the IOM, or supplied with the unit.

4.2 - REFRIGERATION CIRCUIT CHECKS AND RECOMMENDATIONS

In case of split units, check the installation has been made according to the recommendation described § Installation.

The unit refrigeration circuit sketch is given in the «APPENDICES» at the end of the IOM or supplied with the unit.

4.3 - INSTALLATION OF EXTERNAL HYDRAULIC COMPONENTS

Some hydraulic components may be supplied loose by LENNOX:

- | | |
|-----------------------------------|--|
| 01 Kit for groove lock Coupling | A Inlet Outlet water temperature probe |
| 02 Evaporator Water inlet Filter | hot water control option |
| 03 Condenser Water inlet Filter | B Heat exchangers |
| 04 Pressure regulated Water valve | 05 Paddle Flow Switch |

Refer to the “OPTIONS” section for information on connection and installation

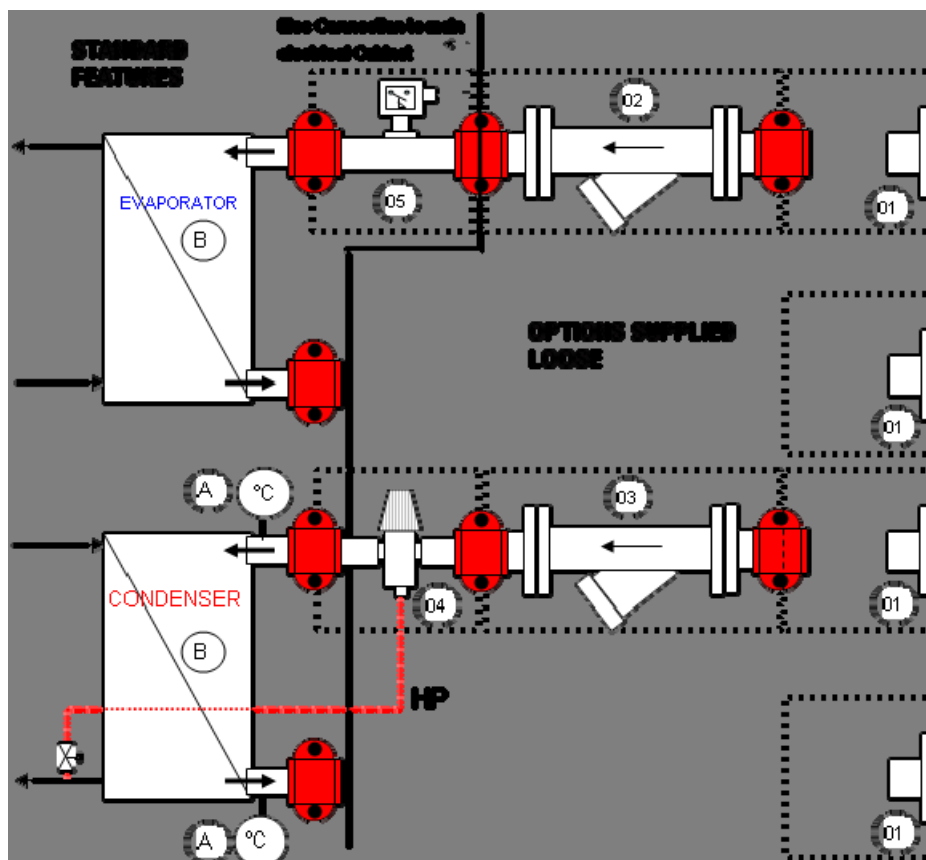



The components are located inside the units or in a separate box and must be installed by a qualified engineer.
 Note: In case of plate heat exchangers it is mandatory that a filter is installed at exchanger unit entrance.

These filters must remove all particles with a diameter greater than 1 mm.

4.4 – HYDRAULIC CONNECTIONS AND OPTIONS

Standard connections are Victaulic type, flange connections and filters are options

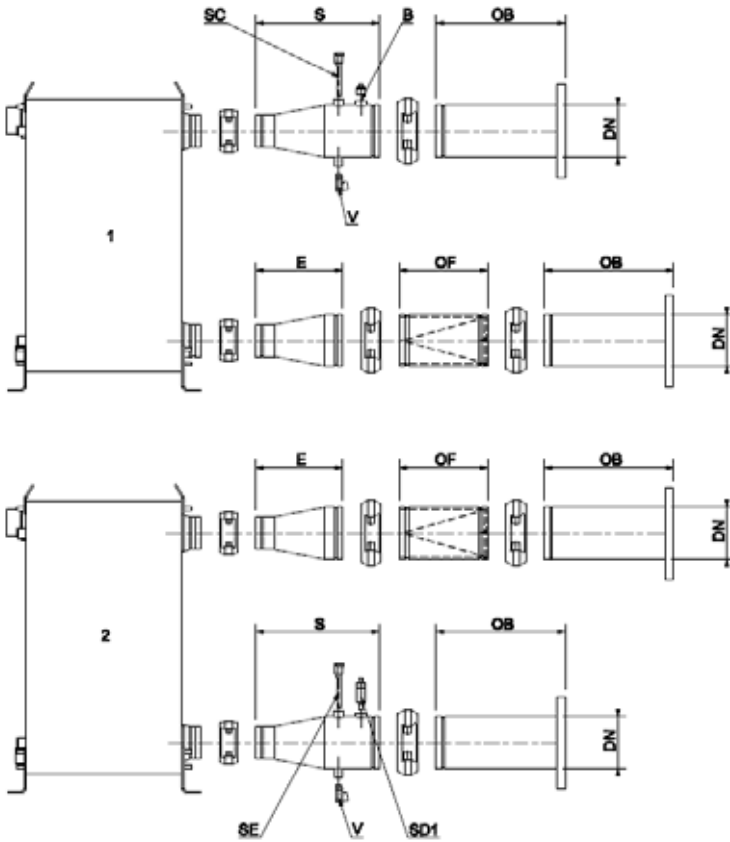

	E	S	OB	OF	SC	SE	DN
MWC 180							
MWC 230							
MWC 280	-	215	80				100
MWC 330						RT.WCOUT	
MWC 380				240		RT.WCOUT	
MWC 450							
MWC 510							
MWC 570	235	335	350				125
MWC 650					RT.WCOUT1 RT.WCOUT2		
MWC 720							

- | | |
|------|---------------------------------|
| 1: | condenser |
| 2: | evaporator |
| B: | plug |
| DN: | diameter |
| E: | water inlet |
| OB: | flange option |
| OF: | filter option |
| S: | water outlet |
| SE: | evaporator sensor + pocket bulb |
| SC: | condenser sensor + pocket bulb |
| SD1: | flow switch |
| V: | valve |

For the commissioning, the flow switch must be mounted on the pipe “S” for the evaporator and connected on the flow switch electrical cable via a special connector. And the outlet sensors must be mounted in the pocket bulbs. The flow switch cable and the outlet sensor cables are already connected to the electrical panel and attached on the frame. The filters are mounted on the heat exchanger inlets.

4.5 - CHECK LIST BEFORE START-UP

Check that all drain and purge plugs are in place and well tightened prior to fill the installation with water or brine. Before proceeding with start up, even for a test of short duration, check the following points, after having made sure that all the valves on the refrigeration circuit are fully open (discharge valves and liquid valves).

Starting up a compressor with the discharge valve closed will either trip the HP safety switch, or blow the cylinder head gasket or the internal pressure safety disc.

1) The liquid pump(s) and other apparatus interlocked with the unit (coils, air handling units, dry coolers, cooling towers, terminals such as fan coil units, etc.) are in working order as required by the installation and according to their own specific requirements.

Place all water valves and refrigerant valves in their operating positions and start the water circulating pumps. Ensure main power supply is isolated before any work is started. Ensure unit is correctly earthed and that earth continuity is correctly done.

Check that anti-vibration mountings are correctly installed and set.

2) **Check the cleanliness and the tightness of all electrical connections**, both the connections made at the factory and the connections made on site. Also make sure that all thermostat bulbs are correctly inserted and tightened in the various wells, if necessary add heat conducting paste to improve contact. Make sure all sensors are correctly fitted and that all capillary tubes are fastened. The technical data printed at the top of the wiring diagram should correspond with those indicated on the unit nameplate.

3) Make sure that the power supplied to the unit corresponds to its operating voltage and that **phase rotation corresponds to the direction of rotation of the compressors** (screw & scroll).

4) Ensure that the water circuits mentioned in 1 are completely filled with water or brine as the case may be; with the air bled out of all high points, including the evaporator ensuring they are perfectly clean and leaktight. In the case of machines with water cooled condensers, the condenser water circuit must be ready to operate, filled with water, pressure tested, bled, filter cleaned after 2 hours of operation of the water pump. Cooling tower in operating condition, water supply and overflow checked, fan in operating condition.

5) Reset all manually resetting safety devices (where necessary).
Open power circuits to all components: compressors, fans....

6) Power up the unit with the main disconnect switch (option). Visually check the oil level in the compressor crankcases (bullseyes). This level may vary from one compressor to another, but should never be higher than the first third of the way up the bullseyes.



CAUTION: Power up the compressor crankcase heaters at least 24 hours before starting the unit. This will enable the refrigerant in the crankcases to evaporate off, and prevents damage to compressors through lack of lubrication during start up.

7) Start the pump(s) check the flow of liquid to be cooled through the heat exchangers: note the inlet and outlet water pressures, and, using the pressure drop curves, calculate liquid flow by applying the following formula:

Actual flow _____

$$Q = Q1 \times \sqrt{(P2/P1)}$$

Where

P2 = pressure drop measured on site

P1 = pressure drop published by LENNOX for a liquid flow of Q1

Q1 = nominal flow

Q = real flow

Adjust the evaporator circuit and condenser circuit water flows (via regulating valves, pump speed position..) to come close to the designed conditions (LENNOX software)

8) Before making any electrical connections, check that insulation resistance between power supply connection terminals is in keeping with applicable regulations. Check the insulation of all electrical motors using a DC 500V megohmmeter, following the manufacturer's instructions.

CAUTION: Do not start any motor whose insulation resistance is lower than 2 mégohms.

Never start any motor while the system is under a vacuum.

4.6 MASTER-SLAVE CONFIGURATION (2 units or more) - For MWC™ units only

In case of 2 units or more that shall operate together, the controller allows several configurations: please consult the controller manual to enter the right parameters.

5 – UNIT START-UP

5.1 - CHECKS TO BE MADE DURING START UP

Before starting the unit, fill in the check list sheet of this manual and follow the instructions below to be sure that the unit is correctly installed and ready to operate.

- 1) Thermometers and pressure switches installed in the chilled water circuit and the condenser water circuit. Check these safety devices in this order: high pressure switch, low pressure switch, fan control pressure switches and thermostats, anti short cycle relay. Make sure all indicator lights operate correctly.
- 2) Run evaporator pump prior to start the chiller.
- 3) Flow switch installed and wired into the control box operates properly.

MWC™ units are fitted with an electronic flow switch as a standard. This flow switch is made of stainless steel and has no moving parts. It detects flow in the water loops by measuring the temperature difference between the heated tip and the base of the probe (With factory setting, it trips off if the speed in the pipe is below 0.6m/s). It is therefore absolutely mandatory to ensure that the base of the measuring element is correctly placed in the water flow.

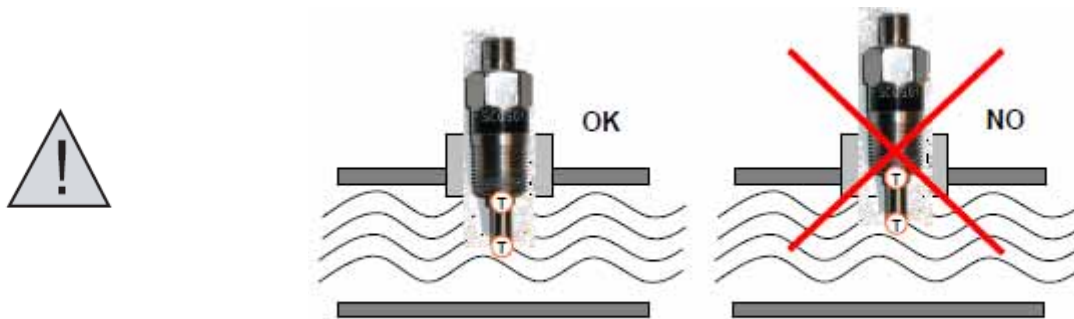

- 4) Check that there is sufficient cooling load on the day the start up is conducted (at least 50 % of the nominal load).

PROCEDURE TO FOLLOW WHEN STARTING THE UNIT

4-a) Press the power “ON-OFF” switch. The compressor will only start if the evaporating pressure is greater than the cut-in set point of the low pressure switch. Check immediately the good rotation of the compressor.



REMEMBER THAT THE COMPRESSOR IS A SCROLL TYPE COMPRESSOR ON MCW™ UNITS:

Before starting the unit, the compressor should be checked that rotates in the correct direction, through a three phase protection. Scroll type compressors only compress in one direction of the rotation. Therefore, it is essential that the phase connection for scroll-type three-phase compressors be carried out correctly (the correct direction of rotation can be checked when the pressure on the suction side decreases and the pressure on the discharge side increases when the compressor is activated). If the connection is wrong, the rotation will be reversed causing a high noise level and a reduction in the amount of current consumed. If this occurs, the compressor’s internal protection system will operate in shutting down the unit. The solution is to disconnect, switch the wires between two of the phases and connect the three again).

ASTP Protection is included with the unit compressors: This device protects the compressor against high discharge temperatures. When the temperature reaches critical values, ASTP protection causes "Scrolls" are separated. Compressor may stop pumping with motor running.

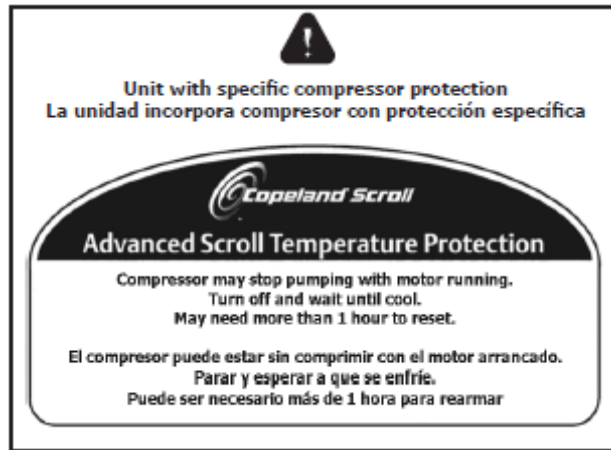

Evaporating pressure drops steadily, the evaporator empties itself of the liquid refrigerant accumulated in it during storage. After a few seconds, the solenoid valve opens if any.

4-b) Check on the sight glass (upstream of the expansion valve if available) that the bubbles disappear progressively, indicating a correct refrigerant charge and without non condensable gas. If the humidity indicator changes colour, indicating the presence of humidity, replace the filter-drier cartridge if the latter is of the replaceable type. The best practice recommends checking the sub cooling after the condenser.

4-c) Check that, when the cooling load has been balanced by the capacity of the unit, the chilled liquid is at design temperature.

5) With the compressor running, check the oil pressure. If there is a fault, do not restart the compressor again until the source of the problem has been located.

6) Check the current values per phase on each compressor motor.

7) Check the current values per phase on each fan motor (If available)

8) Check compressor discharge temperature.

9) Check suction and discharge pressures and compressor suction and discharge temperatures.

10) Check chilled liquid entering and leaving temperatures.

11) Check condenser entering and leaving water temperatures.

12) Check outdoor air temperature in case of split units

13) Check liquid refrigerant temperature at the condenser outlet.

These verifications should be made as quickly as possible with a stable cooling load, i.e. the cooling load of the installation should be the same as the capacity developed by the unit. Measurements taken without heeding this condition will result in unusable and probably wrong values.

These verifications can only be made once the proper operation of all safety devices and unit controls has been established.

5.2 - WATER FLOW CHECKS

The unit control system displays the inlet and water outlet temperature to be displayed. It is very important that the unit operates at the correct water flow rate. It is dangerous to leave the unit operating at a low flow rate as this could result in serious damage to components as well as the water exchanger (on the evaporator side, the flow switch will stop the unit at too low water flows). If the unit operates at too high a flow rate, this will also hinder optimum performance. The second way of determining the operating flow rates (evaporator and condenser side) is to measure the temperature difference between the water in and outlet at full or partial loads.

Checking the water flow rate (it is vital to measure the thermal peak) (Standard unit)

The nominal flows at design conditions and the delta T at design conditions must be used. Now, during start-up, the ambient conditions will often be different from the ambient design conditions, and therefore, the cooling

capacity and the heat rejection of the chiller will be different from those at design conditions. Use the chiller performance charts of the MWC AGU to find the right ΔT on the evaporator and condenser side. For a MWC selected at design conditions, this will give the nominal delta T on the evaporator side (ΔT_{en}), on the condenser side (ΔT_{cn}) and the nominal flows (den and dcn). At ambient start-up conditions, the charts will give start-up flows on the evaporator side (desu) and on the condenser side (dcsu). If the water flows are correct, for this start-up conditions, the delta T on the evaporator (ΔT_{esu}) should be $\Delta T_{esu} = \Delta T_{en} \cdot \text{desu} / \text{den}$ and the delta T on the condenser (ΔT_{csu}) should be $\Delta T_{csu} = \Delta T_{cn} \cdot \text{dcsu} / \text{dcn}$

5.3 - FUNCTIONS AND MAIN REFRIGERANT COMPONENTS

1) Compressor (scroll type): a compressor is a device driven by a motor to bring a refrigerant gas from a low pressure, low temperature phase to a high pressure, high temperature phase

2) Evaporator (brazed plate type): a heat exchanger in which on one side the refrigerant evaporates, thus extracting heat from the water or brine on the other side

3) Condenser (brazed plate type): a heat exchanger in which on one side the refrigerant condensates, thus releasing heat on the other side (water or brine or air if remote condenser)

4) Expansion valve (thermostatic or electronic type): a device that regulates the refrigerant flow to the evaporator

Very important:

The expansion valve fitted on each circuit of the unit has been selected for a given operating range; it must be replaced with a model with the same reference from the same manufacturer.

5) High Pressure switch: This pressure switch initiates unconditional stoppage of the unit if compressor discharge pressure exceeds the operating limits. Reset is automatic. HP setting=42bar

6) High pressure safety relief valve: the ultimate safety device that releases refrigerant if the pressure exceeds the service pressure.

7) Filter Dryer: This is designed to keep the circuit clean and to remove all traces of humidity from within the refrigeration circuit, since this can impair operation of the unit, by acidification of the oil, which causes slow disintegration of the varnish protecting of the compressor motor windings.

8) Oil level controller on MRC version: It prevents the circuit from starting with a too low oil level; it is not activated when the compressors are already running.

9) Crankcase heater: Every compressor is fitted with a single phase crankcase heater that is activated when the compressor stops to ensure separation of the refrigerant and the compressor oil. It is therefore powered up when the compressor is not running.

5.4 - OIL CHARGE

Monobloc units have a complete operating charge of oil when they are shipped, and there is no need to add any oil before start up or afterwards. Note that unit shutdowns by the differential oil pressure switch are usually caused by other problems than a lack of oil in the refrigeration circuits. Overcharging with oil can cause serious problems on an installation, particularly for the compressors. The only time any oil might need adding is when a compressor is replaced.

5.5 - REFRIGERANT CHARGE

Self-contained units have a complete refrigerant charge at the time they are shipped. This charge may need to be topped up when the unit is installed or at other times during the service life of the unit. Additional charge can be introduced through the Schrader valves on the suction line. Every time fluid is added, check the state of the charge with the sight glass if provided and also by the amount of liquid sub cooling at the condenser outlet.



IMPORTANT

- Start up and commissioning must be conducted by LENNOX authorised engineer.
- Never shut of power to the crankcase heaters except for lengthy service operations or seasonal shutdown

6 – OPERATION

6.1 – OPERATING LIMITS



WARNING: It is very important ensure the units operate well inside these envelopes.

6.1.1 –HYDROLEAN™ COOLING AND HEAT PUMP VERSION SIZE 20-25-35-40-50-65-80-90

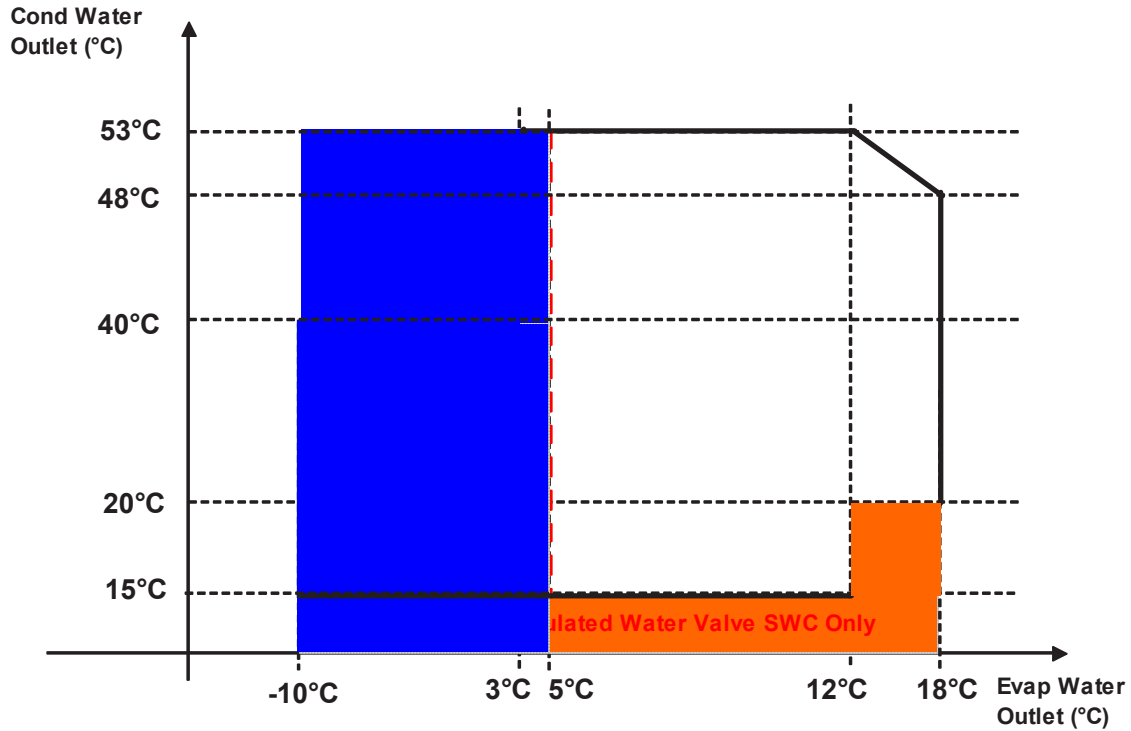

6.1.2 –HYDROLEAN™ COOLING AND HEAT PUMP VERSION SIZE 100-120-135-165

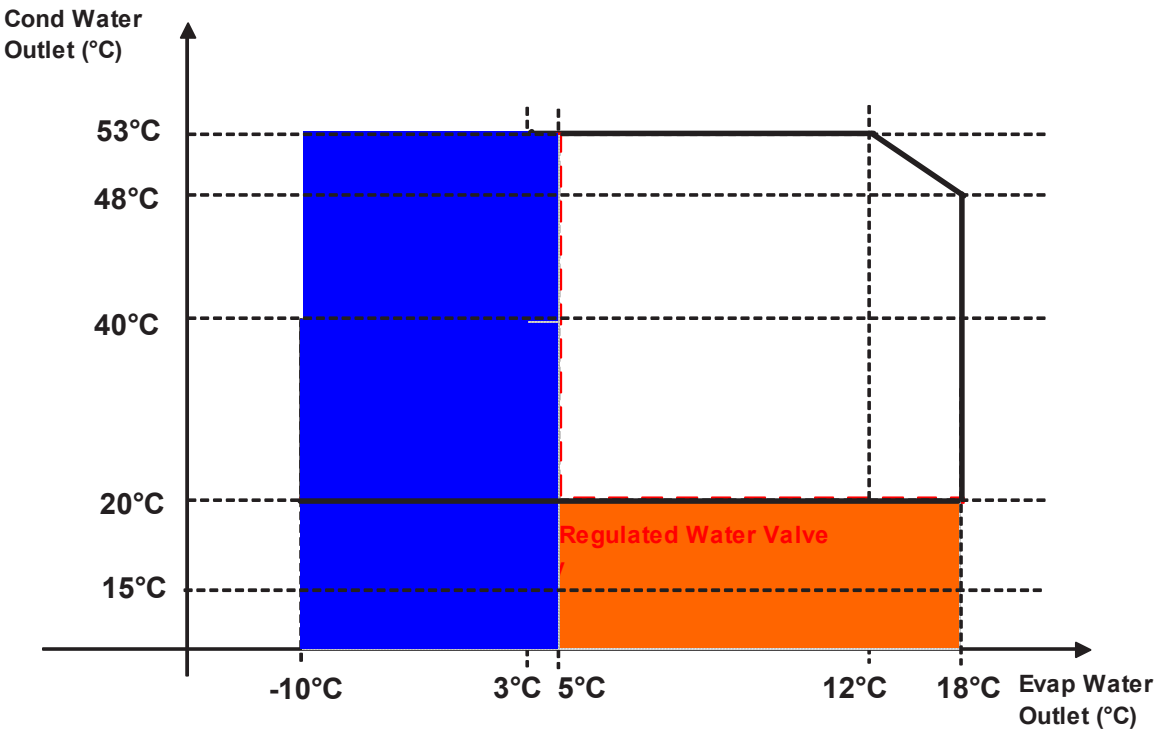

6.1.3 –HYDROLEAN™ WITH REMOTE CONDENSER (ALL SIZES)

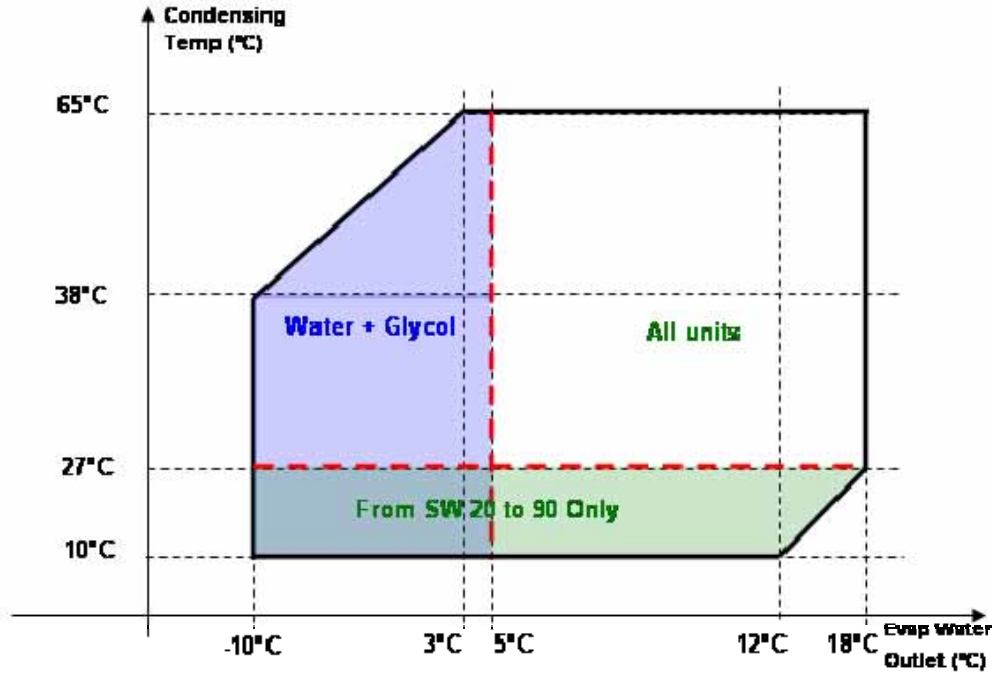

Indication on Pipe sizing for SWR type units

	Discharge Line				Liquid Line			
	Circuit 1		Circuit 2		Circuit 1		Circuit 2	
	Mini Dia. Inches	Min / Max Speed	Mini Dia. Inches	Speed m/s	Mini Dia. Inches	Speed m/s	Mini Dia. Inches	Speed m/s
020	7/8"	10 / 15 m/s	-	-	5/8"	0,5 / 1,5 m/s	-	-
025	7/8"	10 / 15 m/s	-	-	5/8"	0,5 / 1,5 m/s	-	-
035	7/8"	10 / 15 m/s	-	-	5/8"	0,5 / 1,5 m/s	-	-
040	1" 1/8	10 / 15 m/s	-	-	5/8"	0,5 / 1,5 m/s	-	-
050	1" 1/8	10 / 15 m/s	-	-	7/8"	0,5 / 1,5 m/s	-	-
065	1" 1/8	10 / 15 m/s	-	-	7/8"	0,5 / 1,5 m/s	-	-
080	1" 3/8	10 / 15 m/s	-	-	7/8"	0,5 / 1,5 m/s	-	-
090	1" 3/8	10 / 15 m/s	-	-	7/8"	0,5 / 1,5 m/s	-	-
100	1" 3/8	10 / 15 m/s	-	-	7/8"	0,5 / 1,5 m/s	-	-
120	1" 3/8	10 / 15 m/s	1" 3/8	10 / 15 m/s	7/8"	0,5 / 1,5 m/s	7/8"	0,5 / 1,5 m/s
135	1" 3/8	10 / 15 m/s	1" 3/8	10 / 15 m/s	7/8"	0,5 / 1,5 m/s	7/8"	0,5 / 1,5 m/s
165	1" 3/8	10 / 15 m/s	1" 3/8	10 / 15 m/s	7/8"	0,5 / 1,5 m/s	7/8"	0,5 / 1,5 m/s

6.1.4 –MWC™ (ALL SIZES)

MWC version		all sizes
Operating limits (Water Delta T on evap and cond: 5K)		
Min. evap. outlet water temperature	°C	5
Max evap. outlet water temperature	°C	20
Min. difference water inlet/outlet	°C	3
Max. difference water inlet/outlet	°C	8
Min. cond. outlet water temperature	°C	20
Max. cond outlet water temperature		
Operation at full capacity	°C	56

MRC version		all sizes
Operating limits (Water Delta T on evap: 5K)		
Min. evap. outlet water temperature	°C	5
Max evap. outlet water temperature	°C	20
Min. difference water inlet/outlet	°C	3
Max. difference water inlet/outlet	°C	8
Min condensing temperature	°C	25
Max condensing temperature		
Operation at full capacity	°C	62

MWC: Operating Limits

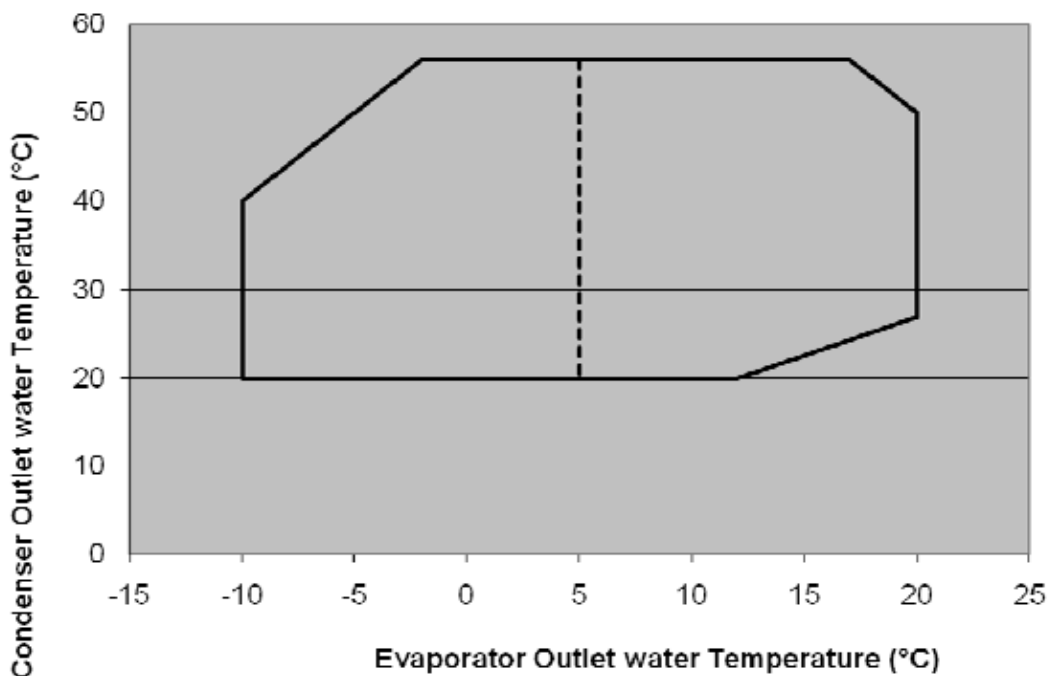

6.2 - UNIT OPERATION: REFRIGERATION CIRCUIT

6.2.1 –TANDEM SCROLL ASSEMBLIES

With “NEW” tandem assemblies the oil balancing is achieved through the use of a large two phase line tube.



It is **IMPERATIVE** that this tube is perfectly level during operation to ensure proper oil balancing between the two crankcases

It is also **IMPERATIVE** for the compressor to be mounted on a rigid base frame as there is no flexibility in the oil equalizing line. The whole assembly can then be mounted on silencers.

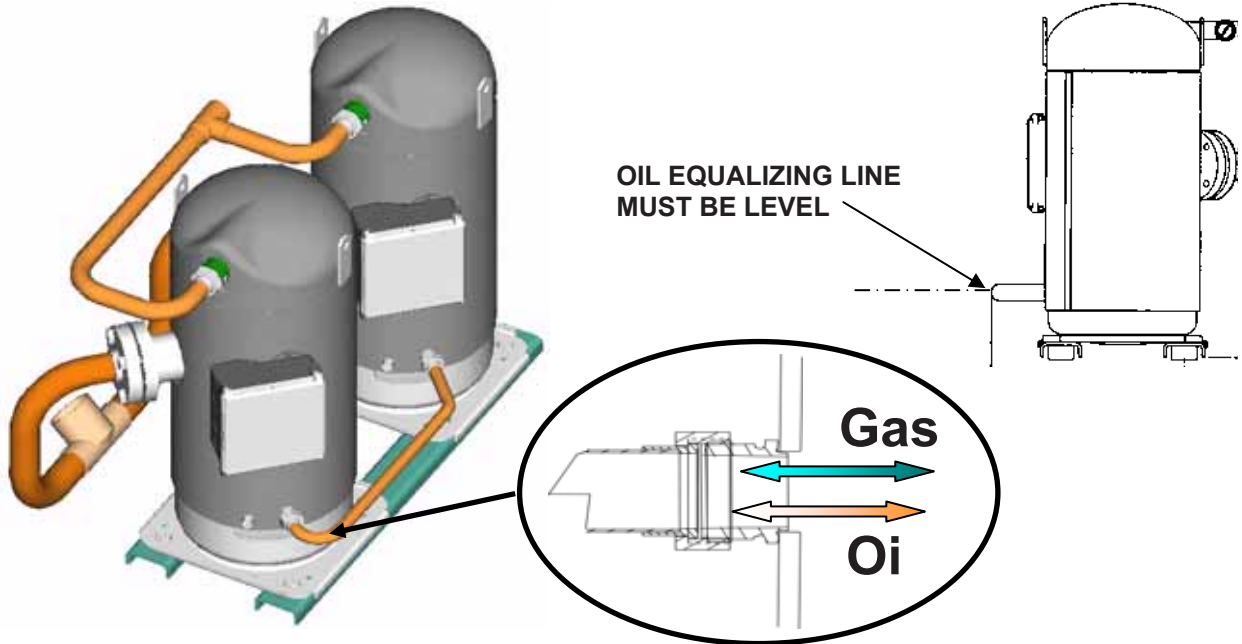

The oil equalizing Line is fitted with a sight glass which can be used to check the oil level in the compressor assembly. It is sometime better to stop both compressors to get a good reading of the oil level in the crankcase of the compressors.

There can be two types of tandem assemblies.

- EVEN TANDEM when both compressors are the same models
- UNEVEN TANDEM when compressors are different models

In the case of uneven tandem assemblies a restrictor is inserted in the suction of one of the two compressors.

The purpose of this restrictor is to equalize the suction pressure in order to ensure a better oil return to both compressors.

Contact LENNOX after sales offices for additional informations.



WARNING: THE UNIT CAN NOT OPERATE WITHOUT A RESTRICTOR IF IT IS REQUIRED

6.2.2 – COPELAND SCROLL DISCHARGE TEMPERATURE PROTECTION (STANDARD)

If the oil in the compressor gets too hot it will start to deteriorate and lose its ability to lubricate, and will eventually cause a compressor failure. LENNOX compressors are sometimes fitted with a specially designed sensor in the hottest part of the compression cycle, just above the discharge port of the scroll sets. This sensor is connected to the solid-state protection module in the terminal box. If the temperature rises above a pre-set value, the compressor will be shut down for **30 minutes before restarting the compressor**.

6.2.3 – THERMOSTATIC EXPANSION VALVE

The thermostatic expansion valve fitted on each machine has been selected for a given operating range; it must be replaced with a model with the same reference from the same manufacturer.

Very important:



The standard expansion valve fitted to the unit was selected for positive chiller water outlet temperatures

6.2.4 – KIT FOR LOW CHILLED WATER TEMPERATURE (OPTION):

This option can only be selected on HYDROLEAN™ Cooling only units SWC.



It is required for unit which operates constantly with chilled water outlet temperatures below 0°C

The Expansion Valve used in low temp applications can not be used with water temperatures over 0°C as the evaporating temperature will remain negative.

It is mandatory to use Glycol on such application.

Special Controller setting for antifreeze protection:

	Factory settings		Min	Max
	Standard	If Option		
A11 - Anti-freeze alarm activation set point	3	-10	-127	127
A12 - Hysteresis of anti-freeze alarm	2	2	0	25,5

6.2.5 – FILTER DRIER (STANDARD):

This is designed to remove all traces of humidity from within the refrigeration circuit, since this can impair operation of the unit, by acidification of the oil, which causes slow disintegration of the varnish protecting the compressor motor windings.

It is of the brazed type on cooling only and Heat pump unit and removable cartridge type on unit for remote condenser

6.2.6 – HIGH AND LOW PRESSURE GAUGES (OPTION):

They enable an instantaneous readout of suction and discharge pressures.

Liquid filled gauges that measure the evaporating Low pressure (LP) and condensing high pressure (HP) on each refrigerant circuit. Gauges are “glycerine” filled to damp gas pulsation and are mounted externally. The gauges are compound gauges that display the saturated refrigerant temperature for the refrigerant R407C.



6.2.7 –SIGHT GLASS (Standard on SWR Not available on Other Models)

This feature when fitted enables visual check of the state of the liquid refrigerant (phase liquid gas or both) in the liquid line, upstream of the thermostatic expansion valve. It also enables to some extent the detection of humidity in the circuit.

6.2.8- CRANKCASE HEATER (Standard)

Every compressor is fitted with a single phase crankcase heater that is activated when the compressor stops to ensure separation of the refrigerant and the compressor oil. It is also powered up when the compressor is not running.

6.2.9 – HIGH PRESSURE SWITCH (Standard)

This pressure switch initiates unconditional shut down of the unit if compressor discharge pressure exceeds the operating limits. Reset is automatic.

- Screw and reciprocating compressor with R407C high pressure switch equal 26.5 bars
- Scroll compressor with R407C high pressure switch equal 29 bars

On HYDROLEAN™ the High pressure switch is Auto reset. The controller will lock the fault preventing a new start up after three faults

6.2.10 - LOW PRESSURE SWITCH (Standard)

This pressure switch initiates unconditional shut down of the unit if evaporating pressure drops below the Low pressure set point value.

On HYDROLEAN™ the Low pressure switch is Auto reset. The controller will lock the fault preventing a new start up after three faults

6.2.11 – PRESSURE REGULATED WATER VALVE (Option)

This device is available as an option for low capacity water cooled condensing units (HYDROLEAN™ or MCW)

The PRESSURE REGULATED WATER VALVE should be installed on the condensing water system. It enables water flow through the heat exchanger to be adjusted so as to maintain condensing pressure at an appropriate value. On HYDROLEAN™ this feature is supplied loose as a kit with refrigerant high pressure line ready to be connected to the valve. An isolating valve is also provided on this high pressure line to isolate the valve in case of leak.



WARNING: It is imperative to avoid any air ingress into the refrigeration system during the connection of the refrigerant High Pressure line to the water valve. The connection to the water pressure regulating valve MUST be checked for refrigerant leaks after installation.

High pressure Lines ready to be connected to the valve

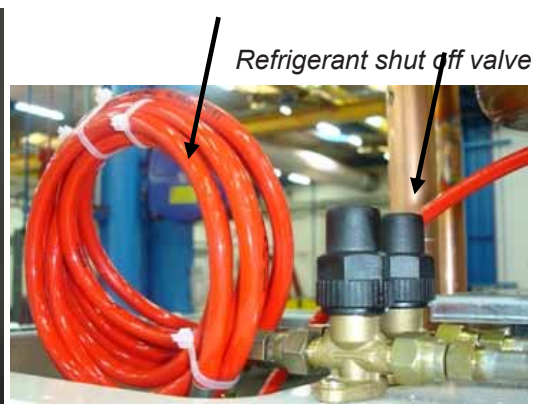
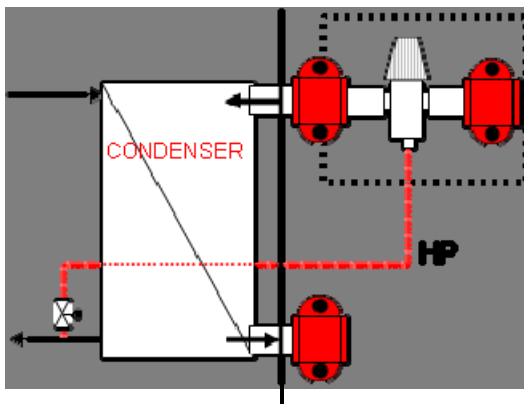

6.3 - UNIT OPERATION: ELECTRICAL AND CONTROL FEATURES

cf. See the specific «Basic CLIMATIC controller» manual

6.3.1 – ANTIFREEZE PROTECTION (Standard):

This feature is provided as standard by the climatic controller: and can be adjusted for brine or glycol/water chilling for which the freezing temperature depends on the concentration of the solution. The antifreeze protection provided causes an immediate shut down of the unit c The controller monitors the chilled water outlet temperature. It then triggers the fault if the temperature goes below the set point value (+ 4°C for water).

6.3.2 –ANTI SHORT CYCLE PROTECTION (Standard):

This device limits the number of compressor start ups. It is a standard feature provided by the controller and it is set to the following value

	Factory setting	Min	Max
C01 OFF- ON delay (x10 sec)	1	0	255
C02 ON - ON delay (x10 sec)	30	0	255
C06 COMP1 ON – COMP 2 ON Delay (x10 sec)	30	0	255
C07 COMP1 OFF – COMP 2 OFF Delay (x10 sec)	0	0	255

6.3.3 –COMPRESSOR MOTOR OVER CURRENT PROTECTION (Standard):

Each compressor is fitted with independent circuit breaker designed to protect each motor winding against accidental over current.

6.3.4 – FLOW SWITCH FOR THE CHILLED WATER (Standard):

This control device is supplied loose as standard on all HYDROLEAN™ and initiates unconditional unit shut down as soon as the flow of chilled liquid (water, brine, etc...) is too low. On HYDROLEAN™ units a cable is provided to connect the external flow switch to the control panel. If the user installs a flow switch himself, electrical connections should be made to the two remote interlock terminals (dry contact).

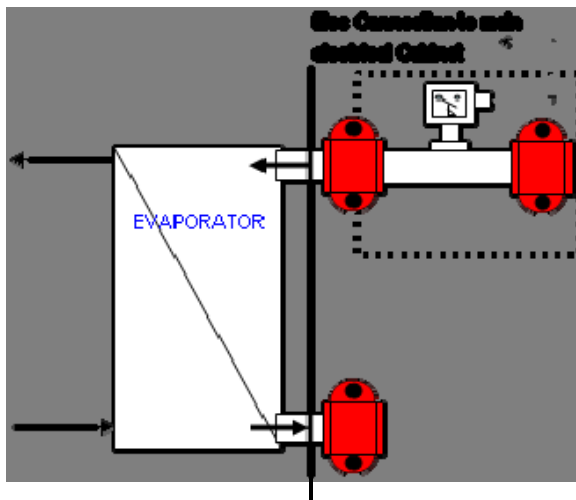

6.3.5 – CONTROL OF EXTERNAL SINGLE PUMP FOR EVAPORATOR (Option):

The optional control and protection of external pump for evaporator can be selected on all HYDROLEAN™ units.

It consists in the addition of a circuit breaker and contactor controlled by the climatic 30. The protection is located in the main electrical panel close to the compressor protections.

The pump parameters can be accessed using the password "38"

		Factory setting	Min	Max
Pump operation mode: Continuous operation "0"	P01	0	0	1
Pump ON - compressor ON delay (seconds)	P02	240	0	255
Compressor OFF - pump OFF delay (seconds)	P03	240	0	255

Size of the protections provided for both evaporator and condenser single pumps

	20 25 35 40	50 65 80 90 100	120	135	165
PMP1 (Max kW with 400V and Cosφ = 0,6)	1,0	1,7	1,7	2,6	4,2
Protection Range Provided (A)	1,6-->2,5	2,5-->4	2,5-->4	4-->6,3	6,0-->10
PMP2 (Max kW with 400V and Cosφ = 0,6)	1,0	1,7	1,7	2,6	4,2
Protection Range Provided (A)	1,6-->2,5	2,5-->4	2,5-->4	4-->6,3	6,0-->10

6.3.6 – CONTROL OF EXTERNAL SINGLE PUMP FOR CONDENSER (Option):

The optional protection of external pump for condenser can be selected on all HYDROLEAN™ units.

It consists in the addition of a circuit breaker and contactor which is switched ON when the unit is On and OFF when the unit is Off.

This contactor can also be controlled by an external signal from the customer's installation: 24V dry contact to be connect-ed directly on the pump 2 contactor.

This protection can be located in the main electrical panel or in an additional electrical cabinet inside the unit depending on the configuration of the Unit and Options.

Wiring for External Pump on Condenser

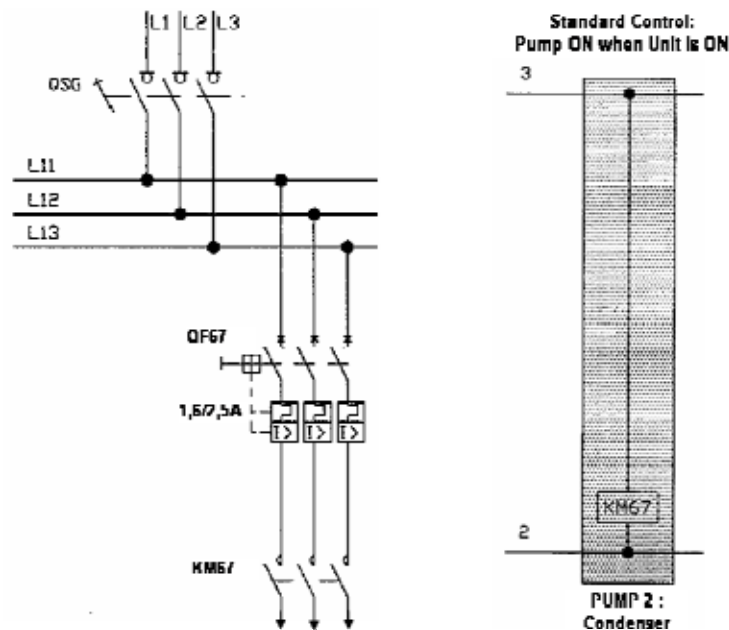

6.3.7 – CONTROL AND PROTECTION OF EXTERNAL FANS (Option)

The optional control and protection of external fans can be selected on all HYDROLEAN™ units.

It consists in the addition of a circuit breaker and contactor per fan and controlled as standard by adjustable pressure switches.

This protection can be located in the main electrical panel or in an additional electrical cabinet inside the unit depending on the configuration of the Unit and Options.

Size of the protection provided

	20 25 35 40	50 65 80 90 100	120 135 165
FAN1 (Max kW with 400V and Cosφ = 0,72)	2	2	2
Protection Range Provided (A)	2,5-->4	2,5-->4	2,5-->4
FAN2 (Max kW with 400V and Cosφ = 0,72)	2	2	2
Protection Range Provided (A)	2,5-->4	2,5-->4	2,5-->4
FAN3 (Max kW with 400V and Cosφ = 0,72)	-	2	2
Protection Range Provided (A)	-	2,5-->4	2,5-->4
FAN4 (Max kW with 400V and Cosφ = 0,72)	-	-	2
Protection Range Provided (A)	-	-	2,5-->4

Wiring for External Fan Protection

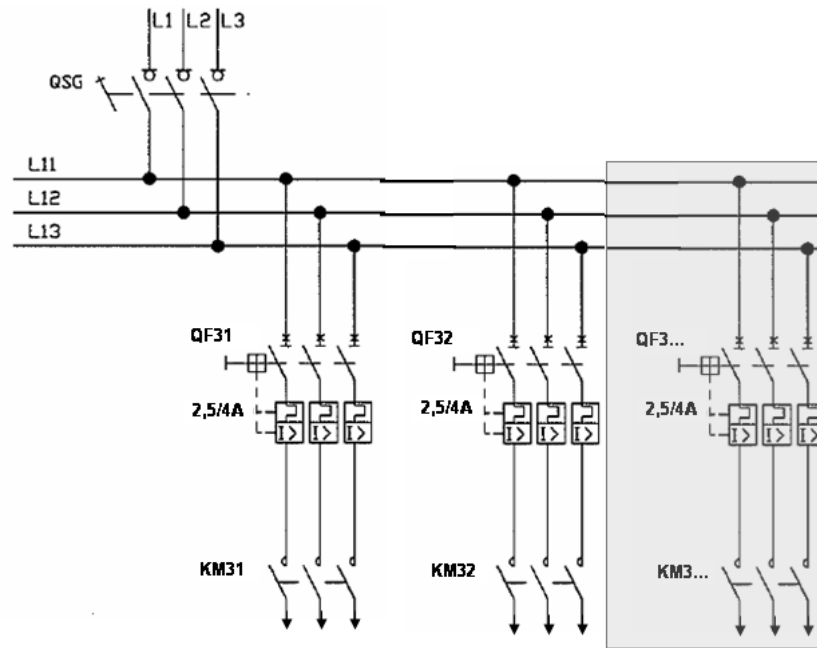

Wiring for Control of External Fan

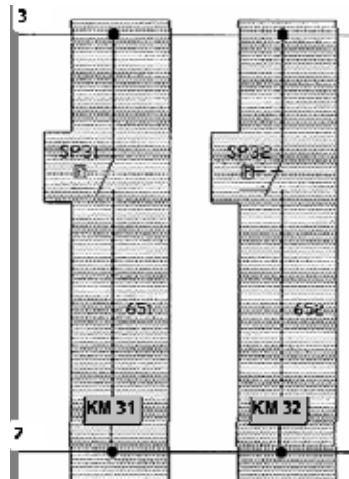



Incompatibilities between Options and Features on HYDROLEAN™

UNIT TYPE AND SIZE	SW 20 25 35 40	SW 50 65 80 90 100	SW 120 135 165
CONTROLLER MODEL	Energy 211B		Energy 620
AVAILABLE OPTIONS & FEATURES	Dynamic Set Point or Remote Heat/Cool or Control on Hot Water	Remote ON / OFF or Dynamic Set Point or Remote Heat/Cool or Control on Hot Water	Remote ON / OFF
	Remote ON / OFF or Control on Hot Water		Dynamic Set Point
			Control on Hot water
			Remote Heat/Cool

6.3.8 – DYNAMIC SET POINT (OPTION)

This option can be selected for all type of HYDROLEAN™ unit and consist in a special configuration of the program and an external temperature probe (provided)

The regulation algorithm can be used to modify the set point automatically on the basis of outdoor conditions. This modification is achieved by adding a positive or negative offset value to the set point depending on the temperature of the outdoor probe.

This function has two purposes: to save energy or to operate the machine under particularly harsh outdoor conditions.

The dynamic set point is active if:

	Factory setting	Min	Max
Probe ST4 is configured as an outdoor probe (Pa H14 = 3)	3	0	3
Pa H31 / H50 = Activation of Dynamic Set Point	1	0	1
Pa H32 / H51 = max offset during cooling	3	-50	80
Pa H33 / H52 = max offset during heating	-4	-50	80
Pa H34 / H53 = Outdoor temperature set point during cooling	35	-127	127
Pa H35 / H54 = Outdoor temperature set point during heating	6	-127	127
Pa H36 / H55 = delta of cooling temperature	-10	-50	80
Pa H37 / H56 = delta of Heating temperature	6	-50	80
Probe ST4 is configured as an outdoor probe (Pa H14 = 3)	3	0	3

Modification depending on outdoor Temperature with positive offset

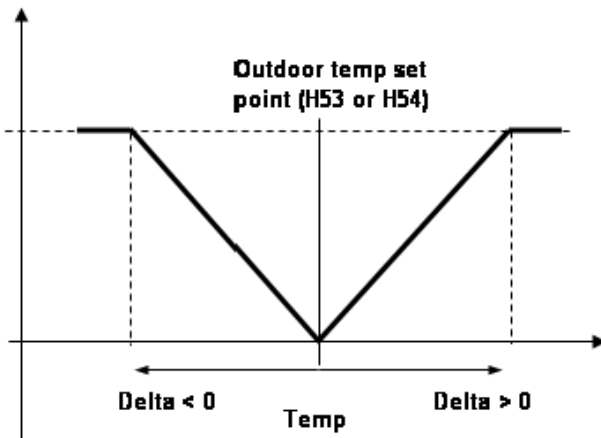

Modification depending on outdoor Temperature with negative offset

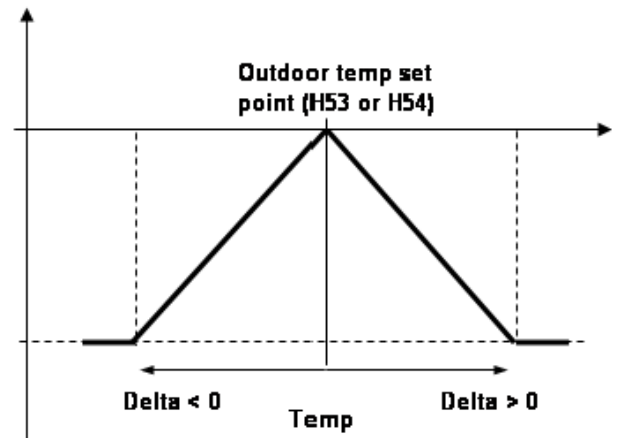

6.3.9 – HOT WATER CONTROL (OPTION)

This option can only be selected on HYDROLEAN™ Cooling only units SWC and consist in a special configuration of the program and temperatures probes fitted to the condenser



It is NOT recommended to use a Pressure Regulating Valve when the Control on Hot Water Option is selected

		20-25-35-40		50-65-80-90-100	120-135-165	
		Control on Hot Water only	Hot Water Ctrl + Dynamic set point	Control on Hot Water Only		Control on Hot Water only
ST4 configuration	H08	2	3	2	-	-
ID5 digital input polarity	H14	1	1	-	-	-
ID digital input configuration	H20	4	3	-	H20	15
ST4 configuration (If Digital)	H21	3	-	3	-	-
ID9 digital input configuration	-	-	-	-	H31	3
Operation mode selection	H27	1	1	1	H49	1
Heat pump presence	H28	1	1	1	H10	1
COMMENTS		Remote ON / OFF on input ID5	Remote ON / OFF Not Available	Remote ON/OFF & Dyn Set Point Not Available		-

6.3.10 – REMOTE HEAT COOL (Standard if no incompatibilities refer to previous page for details)

This option can only be selected on HYDROLEAN™ Heat Pump version SWH and consist in a special configuration of the program. It allows the remote change over from cooling to heating mode.

	Address	20-25-35-40	50-65-80-90-100	120-135-165	
		40	90-100		
ST4 configuration	H08	2	2	-	-
Digital input polarity	H17	1	1	H20	15
ST4 Input configuration (If Digital)	H21	3	3	-	-
ID9 digital input configuration	-	-	-	H31	3
Operation mode selection	H27	1	1	H49	1
Heat pump presence	H28	1	1	H10	1
COMMENTS		Remote ON / OFF on input ID5	Remote ON/OFF & Dyn Set Point Not Available		-

Refer to the unit electrical schematic diagram for information on how to connect the remote Heat Cool signal.

6.3.11 – REMOTE ALARM (Standard)

This feature can be installed on all HYDROLEAN™ units.



WARNING: On units between 20 and 100kW this feature requires the installation of dry contacts: This implies a modification of the customer electrical installation (Max 12V 500mA on the controller). On other sizes fitted with energy 620 controller the dry contacts are already available on the controller

Please find below one possible arrangement for dry contacts on units between 20 and 100kW

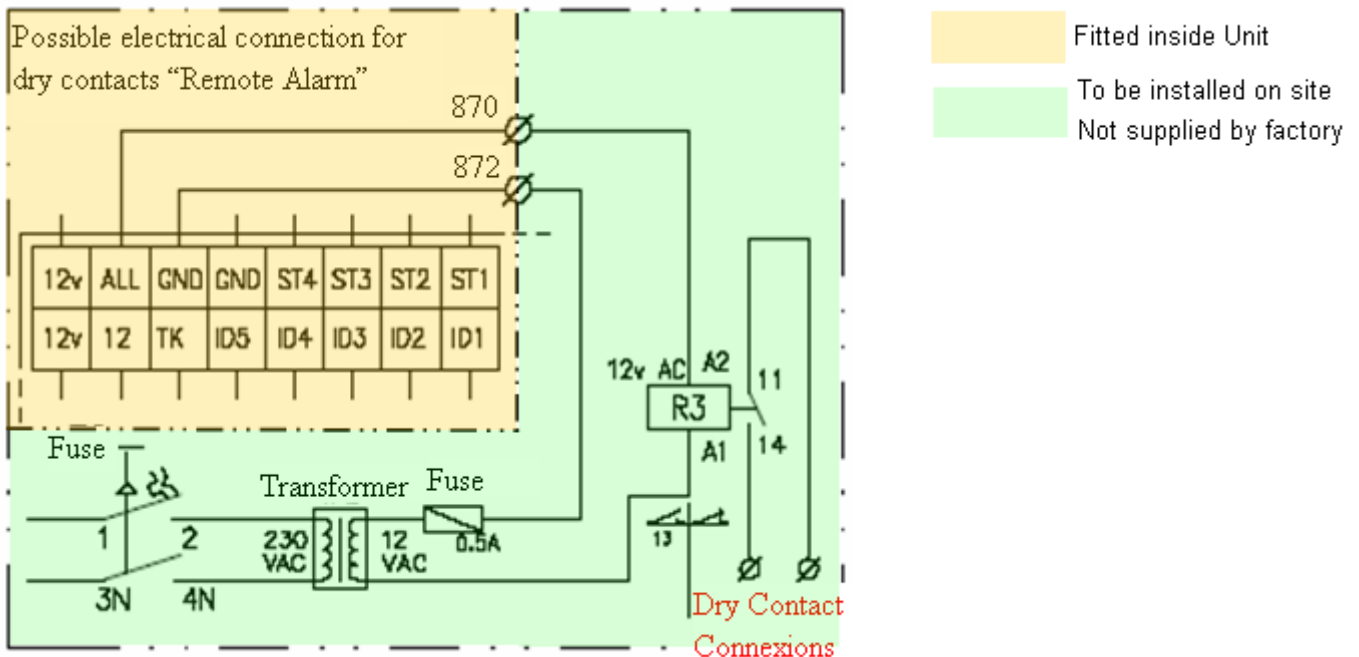

6.4 – OTHER FEATURES AND OPTIONS

6.4.1 –Differential oil pressure safety switch: (only on units with semi-hermetic compressors)

a) Reciprocating compressors:

This pressure switch initiates unconditional unit stoppage if differential oil pressure drops for more than two minutes below a pre-established minimum safety value. Differential oil pressure is the difference between the oil pump discharge pressure and the gas pressure inside the compressor crankcase (suction pressure). The differential oil pressure safety switch is factory set and is not modifiable on site.

b) Screw compressors:

This pressure switch initiates unconditional unit stoppage if differential oil pressure rises above a preset safety value. Differential oil pressure in this case is high pressure less the compressor oil injection pressure.

6. 4.2 - Loss of power supply:

There are no problems restarting the machine after a loss of power supply of short duration (up to about one hour). If loss of power supply lasts longer than this, when power supply is resumed set the unit to «OFF» with the compressor crankcase heaters activated for as long as it takes to bring sump oil back up to temperature, then restart the unit.

7 – MAINTENANCE

We recommend regular and thorough servicing of the LENNOX unit. The following maintenance instructions form a part of the operations required for this type of equipment.

However, it is not possible to give fixed and precise rules for permanent maintenance procedures capable of keeping all units in perfect operating condition since too many factors depending on local conditions specific to the installation, the way the machine is operated, the frequency of operation, climatic conditions, atmospheric pollution, etc. Only trained experienced personnel can establish strict maintenance procedures adapted to the conditions listed above.

Nonetheless, we recommend a regular maintenance schedule:

- 4 times a year for chillers operating all year long
- 2 times a year for chiller that only operate during the cooling season

All operations must be performed in conformity with the maintenance plan; this will extend the service life of the unit and reduce the number of serious and costly breakdowns.

It is essential to keep a «service log», for weekly records of operating conditions of the machine. This log will serve as an excellent diagnostic tool for maintenance personnel ; likewise, the machine operator, by noting down changes in machine operating conditions, will often be able to anticipate and avoid problems before they actually occur or worsen.

The manufacturer cannot be held responsible for any malfunctioning of any equipment it provides if it is caused by a lack of maintenance or by operating conditions beyond those recommended in this manual.

Shown below, and as an illustration only, are some of the most common rules applied for maintenance.

It is therefore advisable to ask your dealer about maintenance contracts. Local legislation must be respected.

7.1 WEEKLY MAINTENANCE

1) Check the compressor oil level. This should be half way up the sight glass with the machine running at full load. Let the compressor operate for 3 to 4 hours before adding any oil. Check the oil level every 30 minutes. If the level does not reach the level indicated above, contact a qualified refrigeration mechanic.

For uneven tandems and trios where the oil level sight glass is on the equalizing line, the control must be done after a complete stop of both compressors. The oil level should be half way up the sight glass.

2) Overcharging with oil can be as dangerous to a compressor as a lack of oil. Before topping up, contact a qualified technician. Only use oils recommended by the manufacturer.

3) Check the oil pressure for semi hermetic compressors.

4) The flow of liquid refrigerant through the sightglass should be steady and without bubbles. Bubbles are a sign of a low charge, a possible leak, or of a restriction in the liquid line. Contact a qualified technician.

Each sight glass is fitted with a humidity indicator. The colour of the element changes according to the level of humidity in the refrigerant, but also according to temperature. It should indicate «dry refrigerant. If it shows «wet» or «CAUTION», contact a qualified refrigeration technician.

CAUTION: When starting up the unit, run the compressor for at least 2 hours before taking a humidity reading. The humidity detector is also sensitive to temperature, and as a consequence, the system must be at normal operating temperature to give a meaningful reading.

5) Check if the operating pressures are higher or lower than those recorded when the machine was put into service.

6) Inspect the entire system so as to detect any eventual abnormality: noisy compressor, loose casing panels, leaky pipes or juddering contacts.

7) Record temperatures, pressures, date and times and any other observations in the service log.

8) Leak detection is recommended.

7.2 ANNUAL MAINTENANCE

On units with water cooled condensers, it is important that the unit be serviced regularly by a qualified technician, at least once every year or every 1000 hours of operation. Failure to observe this rule can lead to cancellation of the warranty and will clear LENNOX of whatever responsibility.

A service visit by a qualified technician is also recommended after the first 500 hours of operation after the unit is first put into service.

- 1) Inspect valves and piping.
- 2) Clean the chilled water piping filters.

CAUTION: The chilled water circuit may be pressurised. Observe the usual precautions when depressurising the circuit before opening it. Failure to observe these rules could lead to accidents and cause injury to service personnel.

- 3) Clean any corroded surfaces and repaint them.

- 4) Inspect the chilled water circuit for any signs of leakage.

Check operation of the water circulating pump and its ancillaries.

Check the percentage of antifreeze in the chilled water circuit, top up as necessary (if antifreeze is used).

- 5) Carry out all weekly maintenance duties.

The first and last inspection will include the seasonal shutdown procedure or the restarting procedure depending on the case.

These inspections should include the following operations:

- Check the contacts of motor contactors and control devices.
- Check the adjustment and operation of each control device.
- Conduct an oil analysis to determine the acidity. Record the results.
- Change the oil if necessary.

WARNING: Oil analyses should be carried out by a qualified technician. Misinterpretation of the results could cause damage to the equipment.

Also, analysis operations should be conducted according to the right procedures, so as to avoid accidents and potential injury of service personnel.

- Follow the recommendations given by LENNOX as concerns compressor oil (see the appropriate table).
- Conduct a refrigerant leak test.
- Check motor winding isolation.

Other operations may be necessary depending on the age and the number of hours of operation of the installation.

7.3 PREVENTIVE MAINTENANCE



PREVENTIVE MAINTENANCE SAVES COSTLY REPAIRS.

Record temperatures, pressures, date and times and any other observations in the service log book. Check maintenance of the following points.

- GENERAL STATE OF THE CASING:

Casing, paint, deterioration due to bumps, rust spots, leveling and supporting, state of the anti-vibration mounts, if installed, screwed panels, etc.

- ELECTRICAL CONNECTIONS:

State of cables, tightness of screws, grounding, current draw of the compressor and fans and checking that the unit is receiving the correct voltage.

- COOLING CIRCUIT:

Check that pressure values are correct and that there are no leaks. Check if the operating pressures are higher or lower than those recorded when the unit was put into service and take into account the impact of the ambient temperature on the operating pressures. Check that there is no damage on the pipe insulation

- COMPRESSOR:

Inspect the oil level. Oil for refrigeration equipment is clear and transparent. It keeps its colour over a long period of operation. Given that a correctly designed and installed refrigeration system will operate without any problems, there is no need to replace the compressor oil even after a very long period of operation. However, oil that has become dark in colour has been exposed to impurities in the refrigeration piping system or to excessive temperatures on the discharge side of the compressor, and this inevitably impairs the

quality of the oil. Darkening of the colour of the oil or degradation of its qualities can also be caused by the presence of humidity in the system. When the oil has changed colour or has been degraded, it must be changed. On request, LENNOX can carry out an oil analysis.

Inspect the state of the compressor mountings.

- CONTROL:

Check Set Points and normal operation.

- WATER:

If the installation contains anti-freeze, regularly check the state of the anti-freeze on the evaporator and condenser side as well as the cleanliness of the water.

- WATER FILTER:

Clean the water inlet filter(s) if necessary.

- WATER PUMP:

When the installation is going to work with percentages of glycol up to 20% and water temperatures below - 5°C, even do we use a specific closing for the water pump, it is advisable to clean the water pump's closing every year and a half, in order to avoid leaks by crystallization.

- PLATE HEAT EXCHANGER(S):

Prove the general isolation state and tightness of the water connections.

- CHECK FOR REFRIGERANT LEAKAGE AND WATER LEAKAGE.

- SIGHT GLASS on MRC version:

The liquid refrigerant flow through the sight glass should be steady and without bubbles. Bubbles are a sign of a low charge, a possible leak, or of a restriction in the liquid line. Each sight glass is fitted with a humidity indicator. The color of the element changes according to the level of humidity in the refrigerant, but also according to temperature. It should indicate «dry refrigerant. If it shows «wet» or «CAUTION», contact a qualified refrigeration technician.

CAUTION: When starting up the unit, run the compressor for at least 2 hours before taking a humidity reading. The humidity detector is also sensitive to temperature, and as a consequence, the system must be at normal operating temperature to give a meaningful reading.

7.4 CLEANING THE CONDENSER

7.4.1 Air cooled condensers

Clean the coils either with a vacuum cleaner, cold water, compressed air, or with a soft brush (non metallic). On units installed in a corrosive atmosphere, coil cleaning should be part of the regular maintenance program. On this type of installation, all dust gathered on the coils should be quickly removed by regular cleaning.

Caution: do not use high pressure cleaners that could cause permanent damage to the aluminium coil fins.

7.4.2 Shell and tube water cooled condensers

Use a cylindrical brush to remove sludge and other substances in suspension inside the condenser tubes. Use a non corrosive solvent to remove scale deposits.

The water circuit in the condenser is manufactured in steel and copper. A water treatment specialist, given the right information, will be able to recommend the right solvent for removing scale.

The equipment to be used for external water circulation, the quantity of solvent and the safety measures to be taken must be approved by the company supplying the cleaning products or by the company conducting these operations.

7.4.3 Plate heat exchanger condensers

Use a non corrosive solvent to remove scale deposits. The equipment to be used for external water circulation, the quantity of solvent and the safety measures to be taken must be approved by the company supplying the cleaning products or by the company conducting these operations.

7.5 COMPRESSORS / OIL DRAINAGE

Oil for refrigeration equipment is clear and transparent. It keeps its colour over a long period of operation.

Given that a correctly designed and installed refrigeration system will operate without any problems, there is no need to replace the compressor oil even after a very long period of operation.

Oil that has become dark in colour has been exposed to impurities in the refrigeration piping system or to excessive temperatures on the discharge side of the compressor, and this inevitably impairs the quality of the oil. Darkening of the colour of the oil or degradation of its qualities can also be caused by the presence of humidity in the system. When the oil has changed colour or has been degraded, it must be changed.

In this event, before putting the unit back into service, the compressor and the refrigeration circuit will have to be evacuated.

7.6 CORRECTIVE MAINTENANCE

! **MAKE SURE THAT THE UNIT IS COMPLETELY DISCONNECTED FROM THE POWER SUPPLY BEFORE CARRYING OUT ANY TYPE OF WORK ON THE UNIT.**

If some component in the cooling circuit must be replaced, follow these recommendations:

- Always use original replacement parts.
- Environment laws stipulate recovery of refrigerants and prohibit their release into the atmosphere.
- If cuts must be made in the pipe work, use pipe cutters. Do not use saws or any other tools that produce filings.
- All brazing must be carried out in a nitrogen atmosphere to prevent corrosion from forming.
- Use silver alloy brazing rod.
- Take special care that the flame from the torch is aimed in the opposite direction from the component to be welded and is covered with a wet rag in order to avoid overheating.

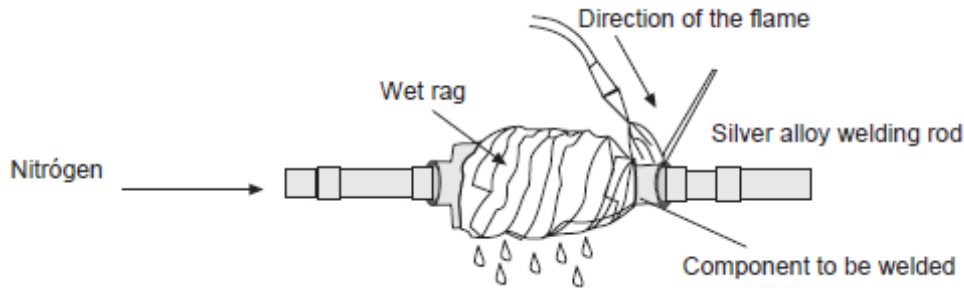

- If a compressor must be replaced, disconnect it electrically and un-braze the suction and discharge lines. Remove the securing screws and replace the old compressor with the new one. Check that the new compressor has the correct oil charge, screw it to the base and connect the lines and electrical connections.
- Carry out the vacuum above and below through the Schrader valves of the outdoor unit until -750 mm Hg is reached.
- Once this level of vacuum has been reached, keep the pump in operation for at least one hour. **DO NOT USE THE COMPRESSOR AS A VACUUM PUMP.** If the compressor runs in vacuum it will fail.
- Charge the unit with refrigerant according to the data on the Name Plate for the unit and check that there are no leaks.

! **PRECAUTIONS TO BE TAKEN IN THE USE OF R-410A REFRIGERANT**

The following precautions characteristic of this gas should be taken:

- The Vacuum Pump must have a Check Valve or Solenoid Valve.
- Pressure Gauges and Hoses for the exclusive use with R-410A Refrigerant should be used.
- The charge should be carried out in the Liquid Phase.
- Always use weighing scales to charge the refrigerant.
- Use the Leak Detector exclusive for R-410A Refrigerant.
- Do not use mineral oil, only synthetic oil to ream, expand or make connections.
- Keep pipes capped before using them and be very thorough about any possible moisture and dirt (dust, filings, burrs, etc.).
- Brazing should always be carried out in a nitrogen atmosphere.
- Reamers should always be well sharpened.
- The refrigerant bottle must contain at least 2 % of the total amount.

7.7 IMPORTANT

Before proceeding with any service operations, make sure that the power supply to the unit is switched off.

When the refrigeration circuit has been opened it will have to be evacuated, recharged, and inspected to ensure that it is perfectly clean (filter-drier) and leak tight. Remember that only trained and qualified personnel are authorised to operate on a refrigeration circuit.

Regulations stipulate recovery of refrigerants and forbid wilful discharge of refrigerants into the atmosphere.

8 – TROUBLESHOOTING – REPAIRS
8.1 LIST OF THE MOST COMMON PROBLEMS

PROBLEMS – SYMPTOMS	PROBABLE CAUSE	RECOMMENDED ACTION
----------------------------	-----------------------	---------------------------

A) THE COMPRESSOR DOES NOT START

- Motor control circuits established, the compressor does not run	- No power supply	- Check main power supply and switch positions
	- Compressor motor burnt out	- Replace
- The system does not start	- Breaker tripped or fuses blown	- Determine the cause. If the system is in running order, close the disconnect
		- Check condition of fuses
	- No water flow in the evaporator or condenser	- Measure flow, check the water pump and water circuitry and filters
	- Flow switch contacts open	- Find the cause of the trip out
		- Check circulation of liquid in the evaporator, and the condition of the flow switch
	- Anti short cycle relay action	- Wait until the anti short cycle time delay has expired
	- Faulty control thermostat	- Check for proper operation, set points, contacts
	- Oil pressure switch tripped	- Check the oil pressure switch and determine the cause of the trip out
	- Antifreeze thermostat or low pressure safety switch tripped	- Check evaporating pressure, the condition of the antifreeze thermostat and the low pressure safety switch
	- Compressor thermal protection relay tripped	- Check for proper operation of the relay
	- High pressure safety switch tripped	- Check the condensing pressure, and the condition of the high pressure safety switch
- (if any) Low pressure safety switch trip out	- Check low pressure safety switch differential	
-On MRC version, too low oil level	- Check the complete refrigerant circuits and search for oil traps and design mistakes - Add oil	

PROBLEMS – SYMPTOMS	PROBABLE CAUSE	RECOMMENDED ACTION
----------------------------	-----------------------	---------------------------

B) THE COMPRESSOR DOES NOT START

- Normal operation with too frequent starts and stoppages due to action of the low pressure safety switch. Bubbles in sight glass. Or, normal compressor operation, but the low pressure safety switch trips out and resets frequently	- Low refrigerant charge	- Check the charge through the Sight glass on the liquid line, carry out a leak test, then top up the refrigerant charge
- Suction pressure too low, Filter drier frozen up	- Filter-drier obstructed	- Check the state of the drier and replace the filter
	- Solenoid valve closed	- Check that the valve is operating properly
	- Expansion valve closed	- Check bulb and capillaries, operation of the valve
	- Compressor suction valve	- Check the filter

C) THE COMPRESSOR SHORT CYCLES ON HIGH PRESSURE SAFETY SWITCH TRIP OUT

	- High pressure safety switch trip out	- Check high pressure safety switch differential
	- Low air/water flow in condenser or dirty condenser coil (poor heat exchange)	- Check that pumps are operating correctly or the state of cleanliness of the coils / check fan operation
	- Incondensable substances in the refrigeration circuit	- Bleed from circuit and top up the refrigerant charge. Note : it is not permitted to discharge refrigerant to atmosphere

D) THE COMPRESSOR RUNS IN LONG CYCLES OR RUNS CONTINUOUSLY

	- Faulty control thermostat	- Check operation
- Temperature too low in the conditioned space	- Chilled water thermostat set too low	- Adjust it
- Bubbles in sight glass	- Low refrigerant charge	- Check the refrigerant charge in the sight glass and top up if necessary
	- Filter-drier partly obstructed	- Check the drier and replace as required, change the filter cartridge
	- Expansion valve partly closed	- Check expansion valve bulb and capillary, measure superheat
	- Liquid line valve not open far enough	- Open the valve completely
- Noisy compressor, or abnormally high suction pressure or low discharge pressure	- Leaky internal compressor valves/seals - Low oil level	- Contact LENNOX, compressor may have to be changed. - Add oil

PROBLEMS – SYMPTOMS	PROBABLE CAUSE	RECOMMENDED ACTION
---------------------	----------------	--------------------

E) THE COMPRESSOR CUTS OUT ON OIL PRESSURE SAFETY SWITCH

	- Oil pressure switch tripped	- Check operation of the oil pressure safety switch
- Oil level in sight glass is too low -	- Oil pressure too low	- Check the oil level in the sight glass on the crankcase, check the cleanliness of the oil filter, check the oil pump
- Visible oil leak / Oil level too low	- Low oil charge	- Check that there is no leakage and add oil
	- Leaky oil sump	- Repair and add oil
- Suction line unusually cold, compressor noisy	- Liquid refrigerant present in the compressor crankcase	- Check appearance of the oil in the sight glass. Measure temperature of the oil pump, measure superheat at the expansion valve, check that the valve bulb is tightly attached
	- Poor heat exchange in the evaporator	- Check water flow. Check fouling by measuring the water pressure drop. Excessive oil migration in the circuit : measure evaporating pressure, superheat and the temperature of the oil pump

F) THE COMPRESSOR CUTS OUT ON ANTIFREEZE PRESSURE SWITCH

	- Antifreeze pressure switch tripped	- Check that the pressure switch is operating properly
	- Low water flow in the evaporator	- Check the water pump
	- Evaporator obstructed	- Determine the degree of fouling by measuring water pressure drop
	- Evaporator frozen up	- Measure pressure drop in water circuit, keep water circulating until evaporator has thawed completely
	- Low refrigerant charge	- Check the refrigerant charge and add refrigerant if necessary
	- Liquid refrigerant in the compressor crankcase	- Check appearance of the oil in the sight glass. Measure superheat at the expansion valve, check that the valve bulb is tightly attached
	- Poor heat exchange in the evaporator	- Check water flow. Check fouling by measuring the evaporator pressure drop. Excessive oil migration in the circuit : measure evaporating pressure, superheat

PROBLEMS – SYMPTOMS	PROBABLE CAUSE	RECOMMENDED ACTION
---------------------	----------------	--------------------

G) THE COMPRESSOR CUTS OUT ON ITS MOTOR PROTECTION THERMAL RELAY

	- Thermal protection Tripped	- Check operation of thermal protection, change it if necessary
	- Motor windings are not being sufficiently cooled	- Measure superheat in the evaporator, adjust it if necessary
	-Compressor operating out of its application range	-Check operating conditions

H) COMPRESSOR CUTS OUT THROUGH ACTION OF THE MAIN POWER FUSE

	- Power supply on two phases only	- Check power supply voltage
	- Faulty motor windings	- Replace the compressor
	- Compressor seized	- Replace the compressor

I) THE COMPRESSOR STARTS WITH DIFFICULTY

	- Faulty windings	- Replace the compressor
	- Mechanical problem	- Replace the compressor

J) THE COMPRESSOR IS NOISY

	- If starting on a single winding on compressors fitted with part winding start or star-delta	- Check operation of the starter contacts, the start up time delay and the condition of the windings
- Compressor knocking	- Broken mechanical parts inside compressor	- Replace the compressor
- Suction line is unusually cold	- Liquid slugging	- Check superheat and that the expansion valve bulb is correctly installed
- High discharge pressure. The water regulating valve or the pressure operated water valve taps or knocks	- Liquid slugging	- Repair or replace
	- Broken suction valves	- Replace broken valves
	- Pressure operated water valve fouled, water pressure is too high or irregular	- Clean the valve. Install and expansion tank upstream of the valve
- Compressor shuts down through action of the oil pressure safety switch	- Low oil charge	- Add oil

PROBLEMS – SYMPTOMS	PROBABLE CAUSE	RECOMMENDED ACTION
----------------------------	-----------------------	---------------------------

K) DISCHARGE PRESSURE TOO HIGH

- Water is far too hot at condenser outlet	- Water flow too low or water temperature too high in the condenser	- Adjust the pressure operated water valve or the thermostat on the cooling tower
- Water is far too cold at the condenser outlet	- Condenser tubes fouled	- Clean the tubes
- Condenser abnormally hot	- Presence of air or incondensibles in the circuit, or excessive refrigerant charge	- Purge incondensibles and/or air, and recover excess refrigerant
- Chilled water leaving temperature too high	- Excessive cooling load	- Reduce load, reduce water flow if necessary

L) DISCHARGE PRESSURE IS TOO LOW

- Water is very cold at condenser outlet	- Condenser water flow too high or water temperature is too low	- Adjust the pressure operated water valve or the thermostat on the cooling tower/dry cooler
- Bubbles in sight glass	- Low refrigerant charge	- Repair the leak and add refrigerant

M) SUCTION PRESSURE IS TOO HIGH

- The compressor runs continuously	- Too much cooling demand on the evaporator	
- Suction line unusually cold. Liquid refrigerant returns to compressor	a) Expansion valve opened too far	a) Adjust superheat and check that the expansion valve bulb is correctly fitted in place. Check parameters for electronic expansion valve.
	b) Expansion valve blocked in open position	b) Repair or replace

N) SUCTION PRESSURE IS TOO LOW

- Bubbles in sight glass	- Low refrigerant charge	- Repair the leak and add refrigerant
- Excessive pressure drop across the filter-drier or the solenoid valve	- Filter-drier obstructed	- Replace the cartridge
- No refrigerant passing through the expansion valve	- Expansion valve bulb has lost its charge.	- Replace the bulb
- Loss of capacity	- Expansion valve obstructed	- Clean or replace
- Conditioned space too cold	- Control thermostat contacts stuck in closed position	- repair or replace
- Compressor short-cycling	- Capacity modulation setting too low	- Adjust
- Superheat value too high	- Excessive pressure drop in the evaporator	- Check the external equalizing line on the expansion valve
- Low pressure drop in the evaporator	- Low water flow	- Check water flow. Check the condition of the filters, look for obstructions in the chilled water circuit piping

8.2 CONTROL DEVICES

Operation

By reacting to compressor discharge pressure, the high pressure switch monitors efficiency of the condenser. Poor efficiency, the result of an excessive condensing pressure, is usually caused by :

- A dirty condenser
- Low water flow
- Low air flow

The low pressure switch monitors the pressure at which the refrigerant evaporates in the evaporator tubes.

Low evaporating pressure is usually caused by:

- Low refrigerant charge
- A faulty expansion valve
- An obstructed liquid line filter-drier
- A damaged compressor cylinder bank unloaded.

The control thermostat monitors chilled water temperature at the evaporator inlet. The most common causes of abnormal temperatures in this zone are:

- Low water flow
- Thermostat setting too low

The oil pressure switch monitors oil injection pressure on the compressor.

Low oil pressure is usually caused by:

- Low oil charge
- A worn or faulty oil pump
- A defective crankcase heater, causing condensation of refrigerant in the oil sump.

The above information does not represent a complete analysis of the refrigeration system. It is intended to familiarise the operator with unit operation and to provide him with the technical data required to enable him to recognise, correct or report a fault.



Only trained and qualified personnel is authorised to service and maintain this equipment.

8.3 REGULAR CHECKS TO BE MADE - CHILLER UNIT ENVIRONMENT

CHILLED WATER CIRCUIT VALUE

- Inlet / Outlet pressure gauges for pressure drop kPa
- Evaporator inlet temperature °C
- Evaporator outlet temperature °C
- Glycol concentration (1)%
- Flow switch operational at % débit
- Chilled water pump interlock []
- Filter on water circuit []

CONDENSER WATER CIRCUIT

- Inlet / Outlet pressure gauges for pressure drop kPa
- Condenser inlet temperature °C
- Condenser outlet temperature °C
- Regulation on condenser water inlet []
- Condenser pump interlock []
- Filter on water circuit []
- Unrestricted air flow on condenser coils (2) []

ELECTRICAL POWER SUPPLY

- Control circuit voltage V
- Power circuit power supply voltage L1/L2 V
- Power circuit power supply voltage L2/L3 V
- Power circuit power supply voltage L3/L1 V

(1) Depending on the application
 (2) According to the type of unit

8.4 MANUFACTURER’S RECOMMENDED INSPECTIONS

8.4.1 - LIQUID CHILLERS WITH RECIPROCATING COMPRESSOR(S)

8.4.1.1 - Number of recommended preventive maintenance visit:

NUMBER OF RECOMMENDED PREVENTIVE MAINTENANCE VISITS
--

Year	Start up	500/1000H visit	Major technical inspection	Inspection visit	15 000 h inspection	30000 h inspection	Tube analysis	
1	1	1		2				
2			1	3				
3			1	3				
4				3	1			
5			1	3			1 ⁽¹⁾	
6			1	3				
7				3		1		
8			1	3				
9			1	3				
10				3		1		1
+10					Every year	3 times a year	Every 15000 hours	Every 30000 hours

This table is published for units operating under normal conditions with an average annual runtime of 4000 hours.

In hostile industrial environments, a specific maintenance visit schedule must be planned.

(1) Depending on the quality of the water

8.4.1.2 - Description of inspection duties - Liquid chiller with reciprocating compressor(s)

START UP

- Check unit installation
- Check water flow and water circuit ancillaries
- Check safety devices
- Check leak tightness
- Configuration of the microprocessor based management system (if used)
- Verification of operating parameters and unit performance
- Transmission of the machine service log

500 H / 1000 H VISITS

- Post wear in inspection
- Oil acidity test, leak test
- Replacement of the filter-drier cartridges depending on the results of the test above.
- Monitor unit performance and any eventual variations linked to use of the installation.

INSPECTION VISIT

- Leak test
- Operating test with record of measurements taken and functional analysis.

MAJOR TECHNICAL INSPECTION

- Inspection visit
- Acid test
- Oil change if necessary
- Replacement of filter-drier cartridges if necessary
- Check up on the microprocessor based management system (if used)
- Adjustment of safety devices
- Verification of unit interlocks
- Lubrication of bearings / dampers if necessary

15 000 H VISIT

- Major technical inspection
- Inspection of the compressor and replacement of valves, springs and seals (depending on the type of compressor).

30 000 H VISIT

- Major technical inspection
- Inspection of the compressors with replacement of the valves, springs, seals and gaskets, bearings, oil discharge valve, piston rings.
- Dimensional inspection of the big ends and dudgeon pins, replacement of parts as required (quotation) (depending on the type of compressor).

TUBE ANALYSIS

- Inspection of water cooled evaporator and condenser tube bundles with an eddy current test to enable potentially serious problems to be anticipated.
- Frequency: Every 5 years up to 10 years (depending on the quality of water), then every 3 years.

8.4.2 - LIQUID CHILLERS WITH SCROLL COMPRESSOR(S)

8.4.2.1 - Number of recommended preventive maintenance visits :

NUMBER OF RECOMMENDED PREVENTIVE MAINTENANCE VISITS

Year	Start up	500/1000H visit	Major technical inspection	Inspection visit	Tube analysis
1	1	1		2	
2			1	3	
3			1	3	
4				3	
5			1	3	1 ⁽¹⁾
6			1	3	
7			1	3	
8			1	3	
9			1	3	
10			1	3	1
+10					Every year

This table is published for units operating under normal conditions with an average annual runtime of 4000 hours.

In hostile industrial environments, a specific maintenance visit schedule must be planned.

(1) Depending on the quality of the water

8.4.2.2 - Description of inspection duties - Liquid chiller with scroll compressor(s)

START UP

- Check unit installation
- Check water flow and water circuit ancillaries
- Check safety devices
- Check leak tightness
- Configuration of the microprocessor based management system (if used)
- Verification of operating parameters and unit performance
- Transmission of the machine service log

500 H / 1000 H VISITS

- Post wear in inspection
- Oil acidity test, leak test
- Replacement of the filter-drier cartridges depending on the results of the test above.
- Monitor unit performance and any eventual variations linked to use of the installation.

INSPECTION VISIT

- Leak test
- Operating test with record of measurements taken and functional analysis.

MAJOR TECHNICAL INSPECTION

- Inspection visit
- Acid test
- Oil change if necessary
- Replacement of filter-drier cartridges
- Check up on the microprocessor based management system (if used)
- Adjustment of safety devices
- Verification of unit interlocks
- Lubrication of bearings / dampers if necessary

TUBE ANALYSIS

- Inspection of water cooled evaporator and condenser tube bundles with an eddy current test to enable potentially serious problems to be anticipated.
- Frequency: Every 5 years up to 10 years (depending on the quality of water), then every 3 years.

8.4.3 - LIQUID CHILLERS WITH SCREW COMPRESSOR(S)

8.4.3.1 - Number of recommended preventive maintenance visits :

NUMBER OF RECOMMENDED PREVENTIVE MAINTENANCE VISITS

Year	Start up	500/1000H visit	Major technical inspection	Inspection visit	Tube analysis
1	1	1		2	
2			1	3	
3			1	3	
4				3	
5			1	3	1 ⁽¹⁾
6			1	3	
7			1	3	
8			1	3	
9			1	3	
10			1	3	1
+10					Every year

This table is published for units operating under normal conditions with an average annual runtime of 4000 hours.

In hostile industrial environments, a specific maintenance visit schedule must be planned.

(1) Depending on the quality of the water

8.4.3.2 - Description of inspection duties - Liquid chiller with screw compressor(s)

START UP

- Check unit installation
- Check water flow and water circuit ancillaries
- Check safety devices
- Check leak tightness
- Configuration of the microprocessor based management system
- Verification of operating parameters and unit performance
- Transmission of the machine service log

500 H / 1000 H VISITS

- Post wear in inspection
- Oil acidity test, leak test
- Replacement of the filter-drier cartridges depending on the results of the test above.
- Monitor unit performance and any eventual variations linked to use of the installation.

INSPECTION VISIT

- Leak test
- Operating test with record of measurements taken and functional analysis.

MAJOR TECHNICAL INSPECTION

- Inspection visit
- Acid test
- Oil change if necessary
- Replacement of filter-drier cartridges
- Check up on the microprocessor based management system
- Adjustment of safety devices
- Verification of unit interlocks
- Lubrication of bearings / dampers if necessary

30000 H VISIT

- Replacement of the compressor and return the old one for revision with replacement of bearing and inspection of compressor geometry
- Major technical inspection
- Start-up of the installation again

TUBE ANALYSIS

- Inspection of water cooled evaporator and condenser tube bundles with an eddy current test to enable potentially serious problems to be anticipated.
- Frequency: Every 5 years up to 10 years (depending on the quality of water), then every 3 years.

9 – CHECK LIST

Machine identifications :	
Year of manufacture :	

NORMAL CONDITIONS OF USE

Leaving chilled water temperature :°C
Outdoor air temperature :	Max :°C
Power supply voltage : V/Ph/Hz
Refrigerant type :	
Date and time measurements were taken :	
Outdoor air temperature :°C
Company responsible for measurements :	
Name of technician :	
Remarks :

		Circuit 1			Circuit 2			Circuit 3	Circuit 4
		Compr. 1	Compr. 2	Compr. 3	Compr. 1	Compr. 2	Compr. 3	Compr. 1	Compr. 1
Number of hours of operation									
Compressors in service per circuit									
Evaporating pressure	Bar								
Suction piping temperature	°C								
Condensing pressure	Bar								
Discharge piping temperature	°C								
Oil pump temperature	°C								
Oil pressure	Bar								
Oil level	A								
Current on phase 1 per compressor	A								
Current on phase 2 per compressor	A								
Current on phase 3 per compressor	°C								
Liquid line temperature	Bar								
Evaporator pressure drop	°C								
Chilled water temperature	°C								
Leaving chilled water temperature	Bar								
Condenser pressure drop	°C								
Condenser entering water	°C								
Condenser leaving water	Bar								
H.P. pressure switch cut-out	Bar								
H.P. pressure switch cut-in	Bar								
Low pressure switch cut-in	Bar								
Oil pressure switch cut-out	Bar								
Antifreeze pressure switch cut-out	Bar								

Fan pressure switch 1 : (cut-out / bar)	Fan 2 :	Fan 3 :	Fan 4 :
--	---------	---------	---------

This check list should be filled in by the contractor to make sure that unit installation takes place according to appropriate industry practices.

WARNING: Disconnect the power supply before carrying out any inspections on the unit. If the unit must be left powered up, proceed with precaution to avoid risk of electrocution.

Note: some units have a separate control circuit supply that is not isolated when the main power supply is OFF. This must be isolated separately.

RECEPTION

- ☒ Check absence of transport damage
- ☒ Check for missing items
- ☒ Availability of suitable lifting gear, slings and spacers

UNIT INSTALLATION

- ☒ Shipping crate removed
- ☒ Clearances checked
- ☒ Vibration isolators mounted
- ☒ Unit set in place
- ☒ Unit levelled

CHILLED WATER CIRCUIT

- ☒ All piping checked for leakage
- ☒ Thermometers installed
- ☒ Water pressure regulator installed
- ☒ Balancing valves installed
- ☒ Flow switch installed
- ☒ System rinsed, cleaned and filled before being connected to the unit. Check presence of filter on unit inlet and state of cleanliness of the filter.
- ☒ Checked operation of the pump and evaporator pressure drop

CONDENSER WATER CIRCUIT

- ☒ Checked order of power supply phases for scroll and screw compressor units
- ☒ All piping checked for leakage
- ☒ Thermometers installed
- ☒ Water pressure regulator installed
- ☒ System balancing valves installed
- ☒ System rinsed, cleaned and filled before being connected to the unit. Check presence of filter on unit inlet and state of cleanliness of the filter.
- ☒ Checked operation of the pump and condenser pressure drop

ELECTRICAL EQUIPMENT

- ☒ Check the main power supply matches the unit data plate.
- ☒ Check that the unit is correctly earthed
- ☒ Checked order of power supply phases for scroll and screw compressor units
- ☒ Checked correct direction of rotation of fan motors and proper operation of the latter.
- ☒ Direction of rotation of pump correct
- ☒ Control cabinet wired up.
- ☒ Power supply conforms with unit nameplate indications
- ☒ Pump starter and flow switch circuits complete and in working order
- ☒ Pipe heaters installed on all piping exposed to freezing temperatures
- ☒ All unions tightened with a torque wrench

GENERAL

- ☒ Cooling load available, minimum 50 %
- ☒ Coordination between different professions for final commissioning

CUSTOMER ORDER NUMBER: LENNOX REFERENCE:

DESIGNATION:

COMMENTS:

.....

NAME: SIGNATURE:

APPENDICIES

APPENDIX 1: GENERAL REFRIGERATION CIRCUIT DIAGRAM: HYDROLEAN™ COOLING ONLY

020 - 025 - 035 - 040

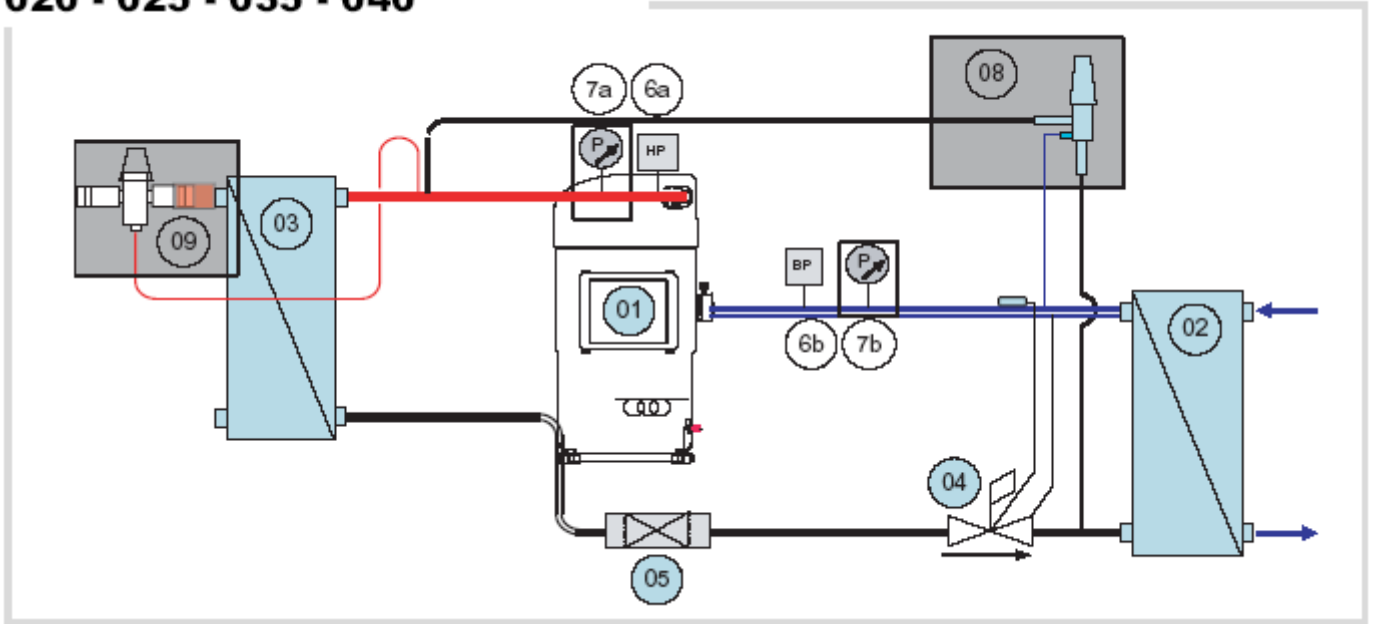

050 - 065 - 080 - 090 - 100

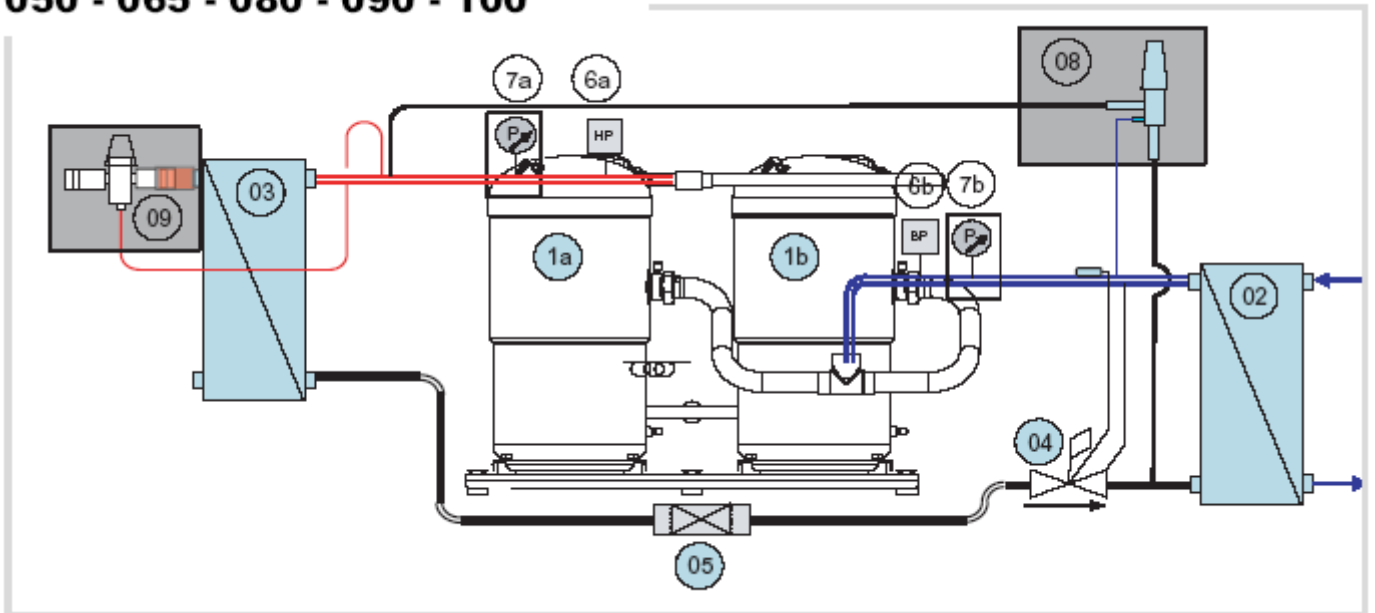

Standard Components		Options	
01.a/ 01.b/ 01.c	Compressors	07a/ 07b/	Low & high pressure gauges
02	Evaporator	08	Hot gas by-pass
03	Condenser	09	Pressure regulated water valve
04	Thermostatic expansion valve		
05	Filter drier		
06	Low & high pressure switch		

120 - 135 - 165

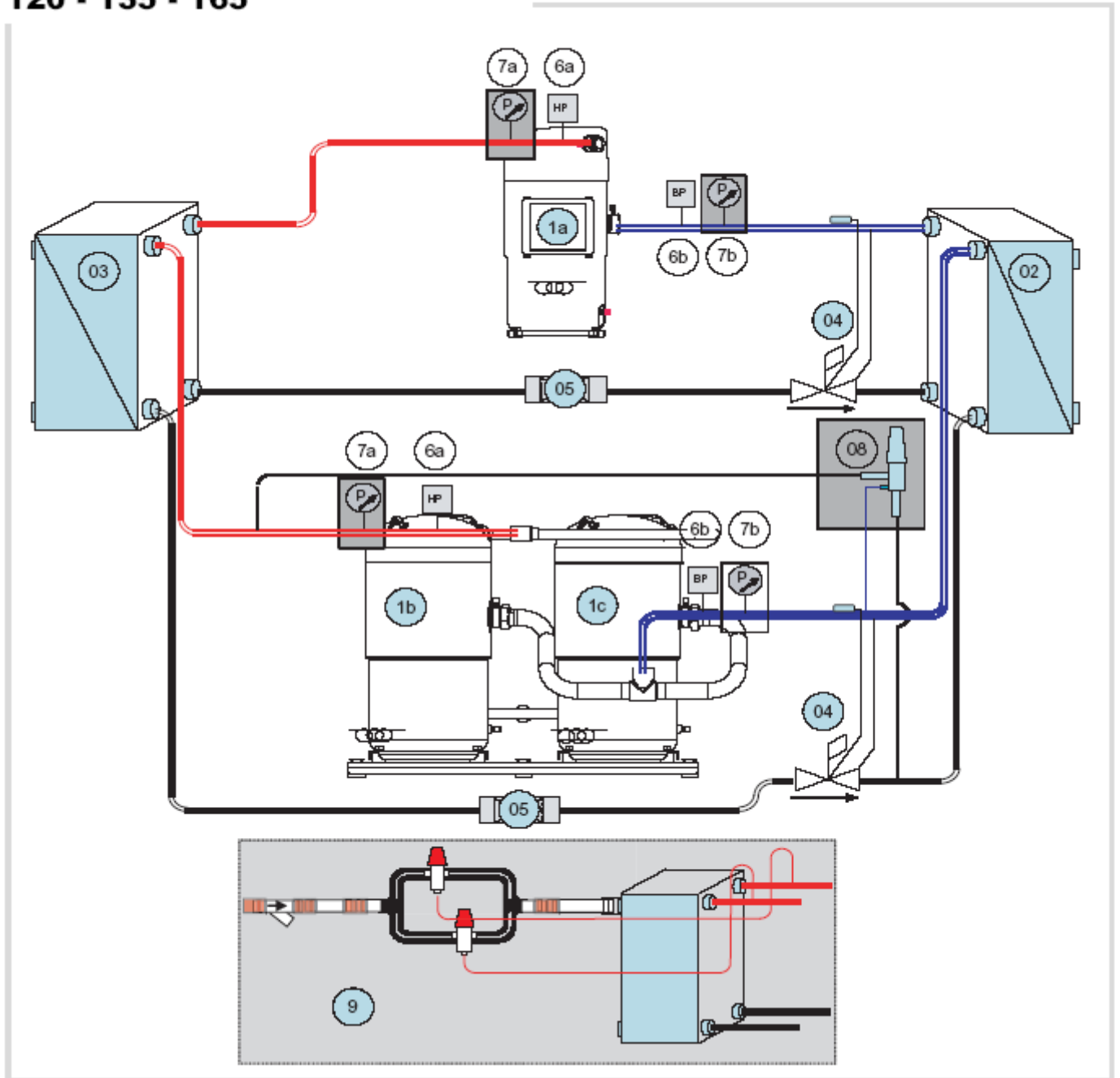

Standard Components		Options	
01.a/ 01.b/ 01.c	Compressors	07a/ 07b/	Low & high pressure gauges
02	Evaporator	08	Hot gas by-pass
03	Condenser	09	Pressure regulated water valve
04	Thermostatic expansion valve		
05	Filter drier		
06	Low & high pressure switch		

APPENDIX 2: GENERAL REFRIGERATION CIRCUIT DRIAGRAM: HYDROLEAN™ HEAT PUMP
020 - 025 - 035 - 040

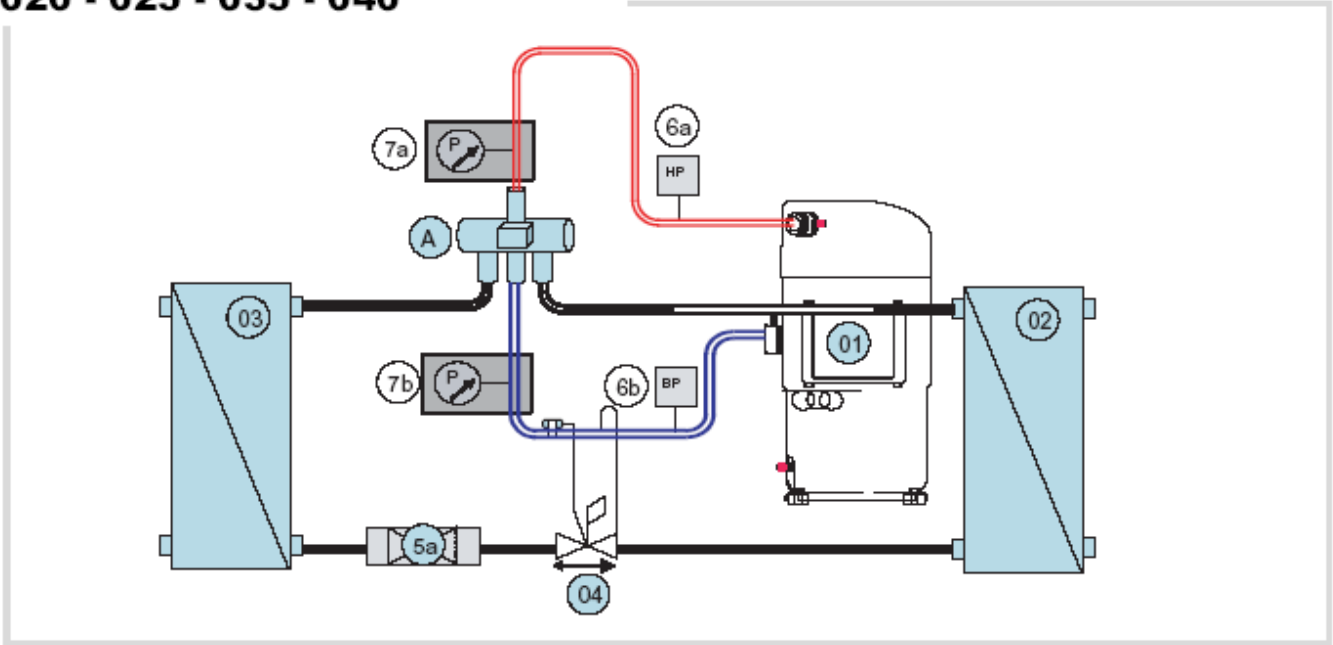

050 - 065 - 080 - 090 - 100

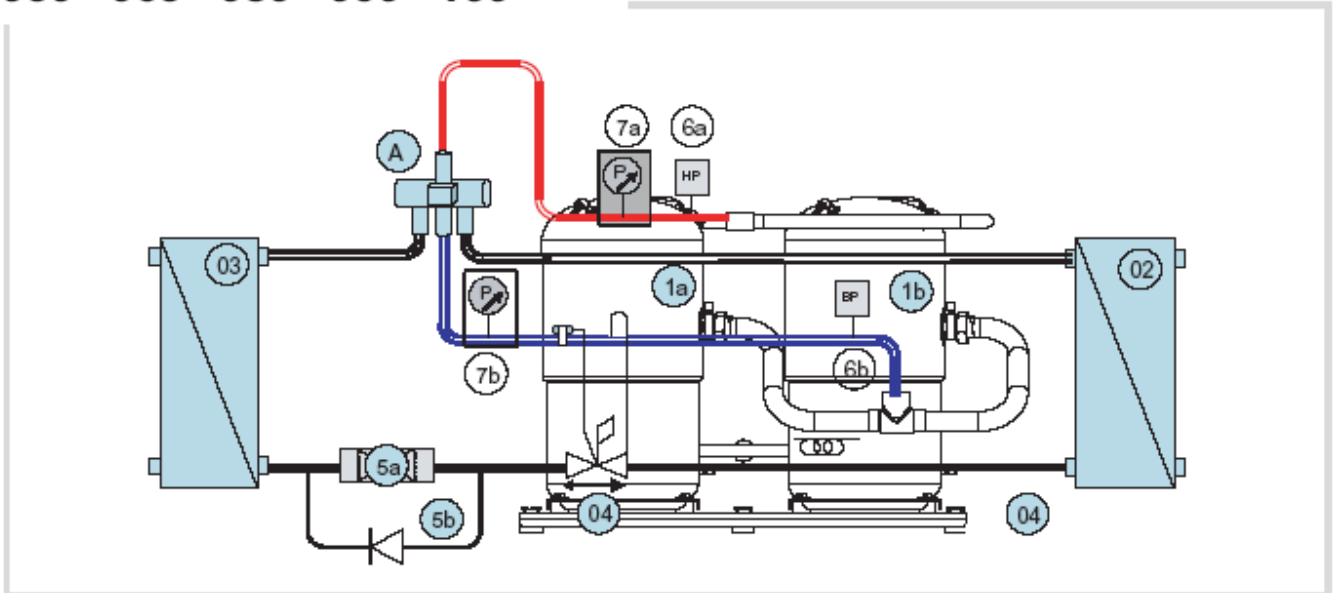

Standard Components		Options	
01.a/ 01.b/	Compressors	07a/ 07b/	Low & high pressure gauges
02	Evaporator		
03	Condenser		
04	Thermostatic expansion valve		
05.a 05.b	Filter drier & filter by-pass		
06.a 06.b	Low & high pressure switch		
A	4 way reversing valve		

120 - 135 - 165

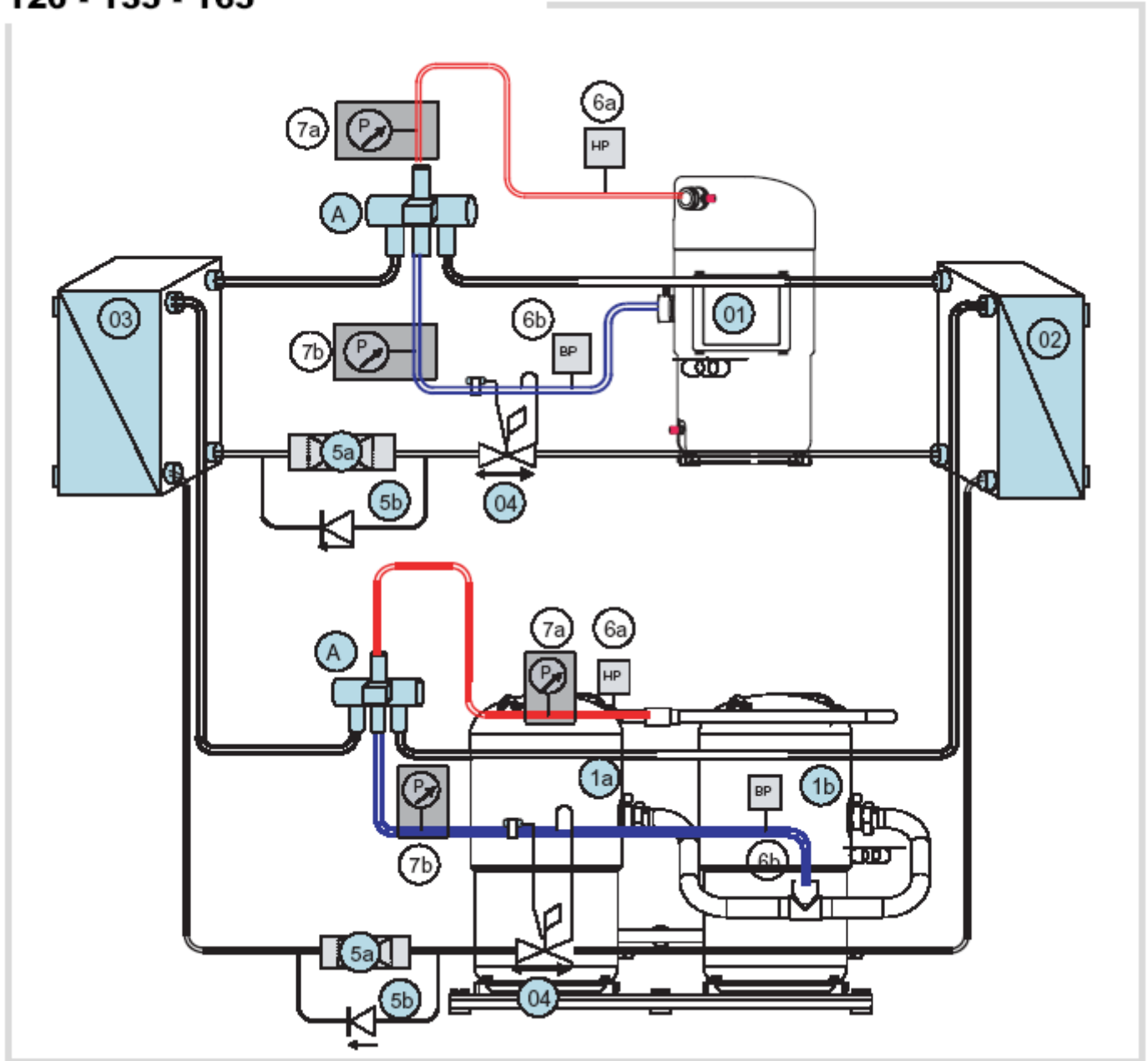

Standard Components		Options	
01.a/ 01.b/	Compressors	07a/ 07b/	Low & high pressure gauges
02	Evaporator		
03	Condenser		
04	Thermostatic expansion valve		
05.a 05.b	Filter drier & filter by-pass		
06.a 06.b	Low & high pressure switch		
A	4 way reversing valve		

**APPENDIX 3: GENERAL REFRIGERATION CIRCUIT DRIAMGRAM: HYDROLEAN™
REMOTE CONDENSER**

020 - 025 - 035 - 040

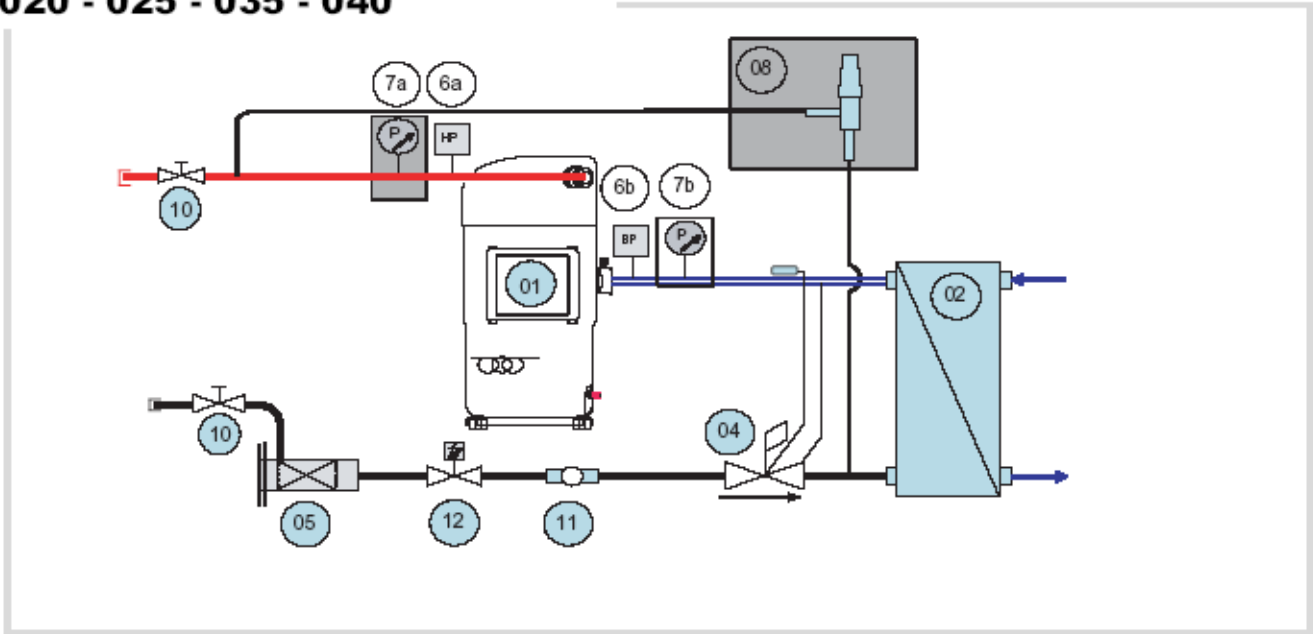

050 - 065 - 080 - 090 - 100

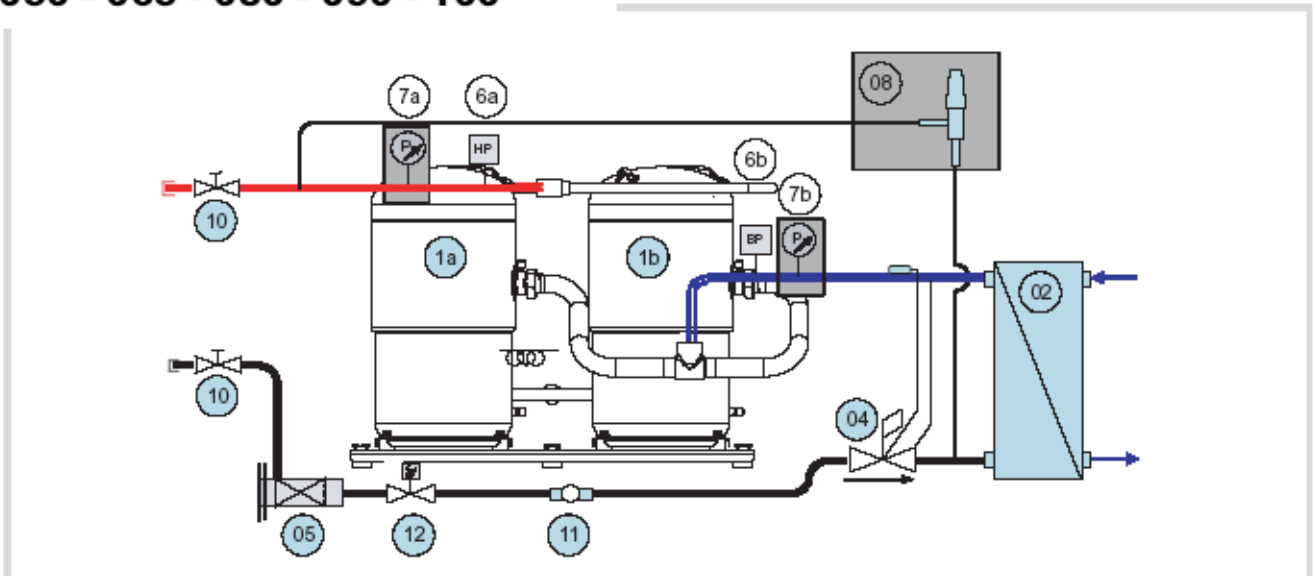

Standard Components		Options	
01.a/01.b/ 01.c	Compressors	07a/ 07b/	Low & high pressure gauges
02	Evaporator	08	Hot gas by-pass
03	Condenser		
04	Thermostatic expansion valve		
05	Removable cartridge drier filter		
06.a/06.b	Low & high pressure switch		
10	Manual shut-off valve		
11	Sight glass		
12	Liquid solenoid valve		

120 - 135 - 165

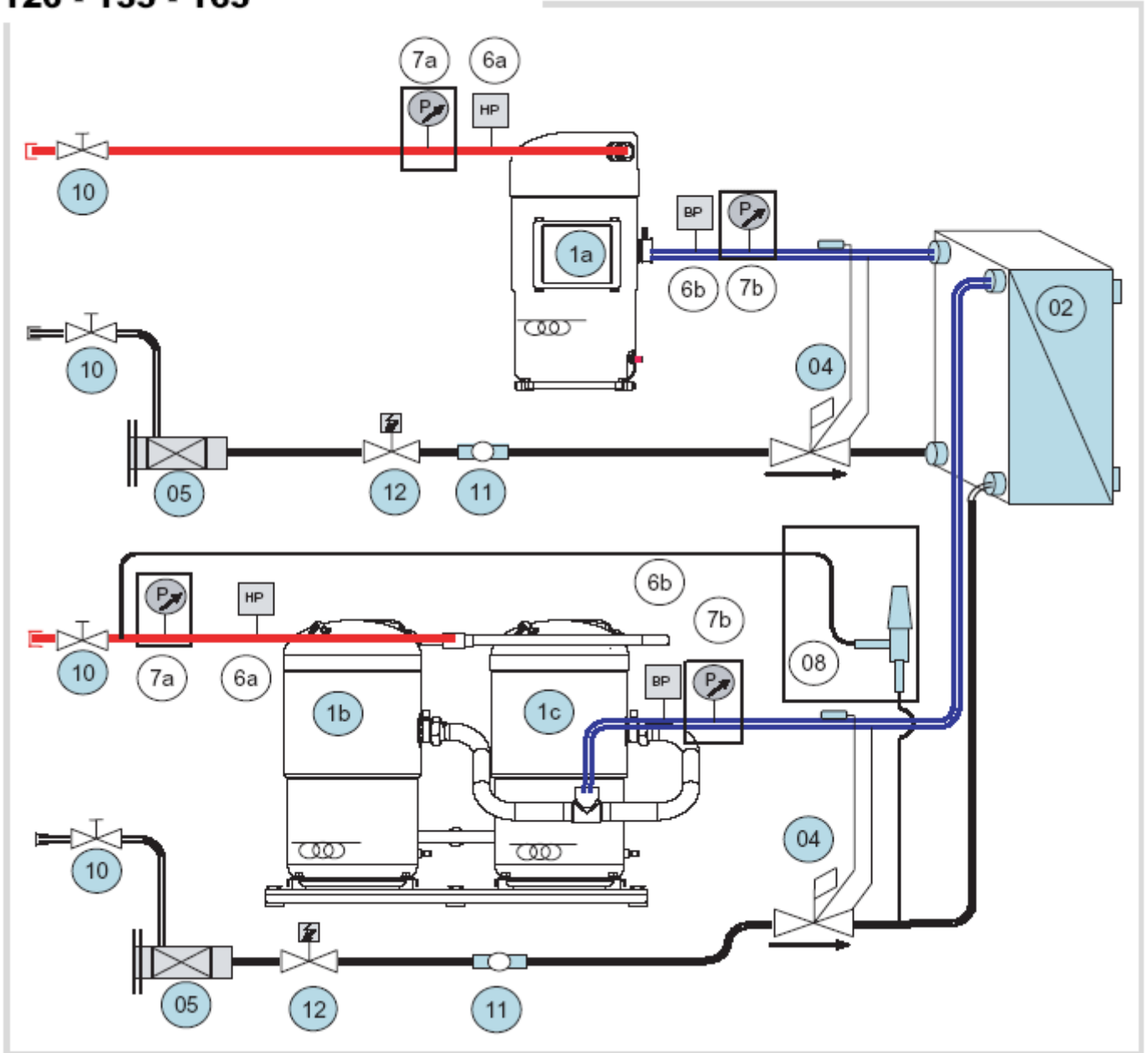

Standard Components		Options	
01.a/01.b/ 01.c	Compressors	07a/ 07b/	Low & high pressure gauges
02	Evaporator	08	Hot gas by-pass
03	Condenser		
04	Thermostatic expansion valve		
05	Removable cartridge drier filter		
06.a/06.b	Low & high pressure switch		
10	Manual shut-off valve		
11	Sight glass		
12	Liquid solenoid valve		

APPENDIX 4: GENERAL REFRIGERATION CIRCUIT DRIAGRAM: MWC™

Circuit 1 & 2: 2 or 3 compressors per circuit:

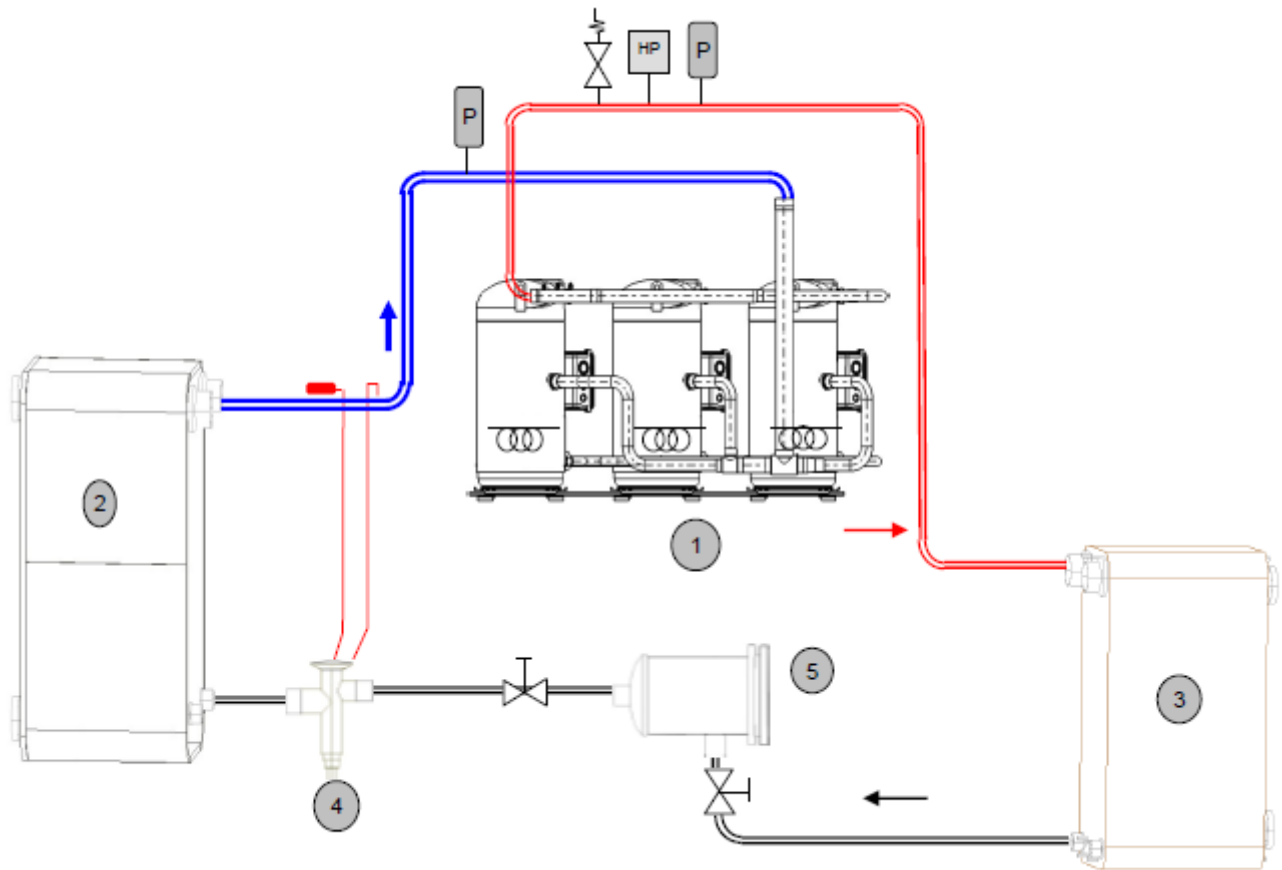

Main Components

- | | | |
|---------------------------|--|-----------------------------------|
| 1 Compressors | | High pressure relief valve |
| 2 Water cooled evaporator | | High pressure safety switch |
| 3 Water cooled condenser | | High and low pressure transducers |
| 4 Expansion valves | | Crankcase heaters |
| 5 Cartridge filter drier | | |

Circuit 1 & 2: 2 or 3 compressors per circuit:

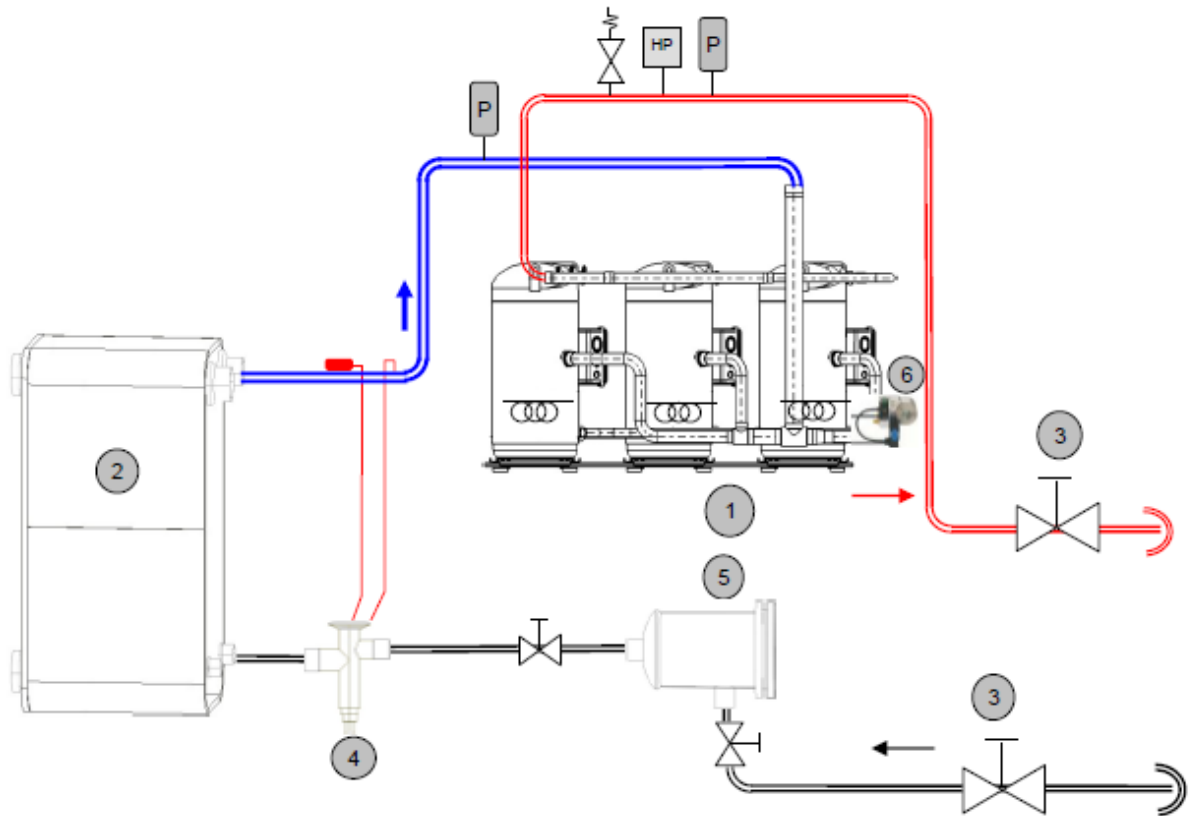

Main Components

- | | | |
|---------------------------|--|-----------------------------------|
| 1 Compressors | | High pressure relief valve |
| 2 Water cooled evaporator | | High pressure safety switch |
| 3 Manual shut off valve | | High and low pressure transducers |
| Expansion | | Crankcase heaters |
| 4 valves | | |
| Cartridge filter | | |
| 5 drier | | |
| Oil level | | |
| 6 controller | | |

APPENDIX 5: GENERAL MECHANICAL DRAWING

HYDROLEAN™ 20-25-35-40

	0	1	2	3	4	5	6	7	8	9
--	---	---	---	---	---	---	---	---	---	---

Load Distribution (Kg - Operating weights)

SWC		SWH		SWR	
G1	G2	G1	G2	G1	G2
020	31 31	020	31 31	020	29 29
025	48 48	025	49 49	025	47 47
035	53 53	035	54 54	035	50 50
040	60 60	040	60 60	040	57 57
D1	D2	D1	D2	D1	D2
020	31 31	020	31 31	020	29 29
025	48 48	025	49 49	025	47 47
035	53 53	035	54 54	035	50 50
040	60 60	040	60 60	040	57 57

Piping - A BOX (20/25/35/40)

	SWC/SWH	SWR
EVAPORATOR	All Units	All Units
Inlet Water (A)	1"1/4 - DN32	1"1/4 - DN32
Outlet Water (B)	1"1/4 - DN32	1"1/4 - DN32
CONDENSER	All Units	20>35 40
Inlet Water (C)	1"1/4 - DN32	
Liquid Line (D)		5/8" 5/8"
Outlet Water (D)	1"1/4 - DN32	
Discharge Line (C)		7/8" 1"1/8

Clearances

Dimensional Data

Option Rubber Antivibration Mounts

Hydrolean SWC	020	025	035	040
Rubber Mounts Type	APK80/45Sh A		APK80/60Sh A	
Number/machine	4		4	
Height (C) mm	27		27	
Thread dia (E) mm	M8		M8	
Max. Thread Length mm	10		11.8	

A BOX									
Indice	DATE	NOM	MODIFICATIONS						

MECHANICAL DATA

3

HYDROLEAN™ 50 65 80 90 100

Load Distribution
(Kg - Operating weights)

SWC		SWH		SWR	
G1	G2	G1	G2	G1	G2
050	98	050	99	050	95
065	106	065	108	065	101
080	111	080	113	080	102
090	121	090	122	090	110
100	133	100	135	100	122
D1	D2	D1	D2	D1	D2
050	98	050	99	050	95
065	106	065	108	065	101
080	111	080	113	080	102
090	121	090	122	090	110
100	133	100	135	100	122

Piping - B BOX (50/65/80/90/100)

	SWC/SWH	SWR
EVAPORATOR	All Units	All Units
Inlet Water (A)	2" - DN50	2" - DN50
Outlet Water (B)	2" - DN50	2" - DN50
CONDENSER	All Units	50>65 80>100
Inlet Water (C)	2" - DN50	
Liquid Line (D)		7/8" 7/8"
Outlet Water (D)	2" - DN50	
Discharge Line (C)		7/8" 1"1/8

Clearances

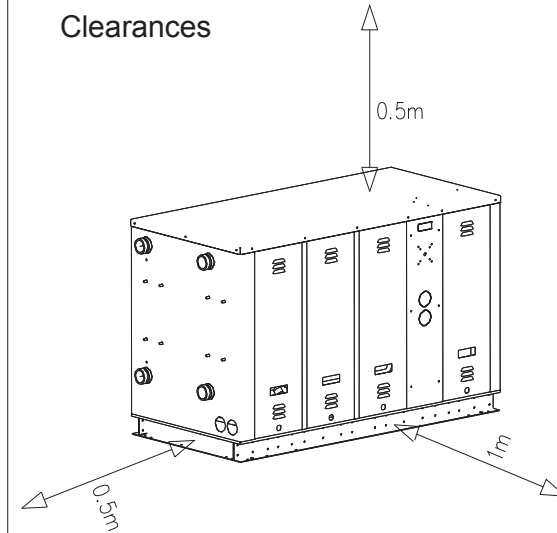

Dimensional Data

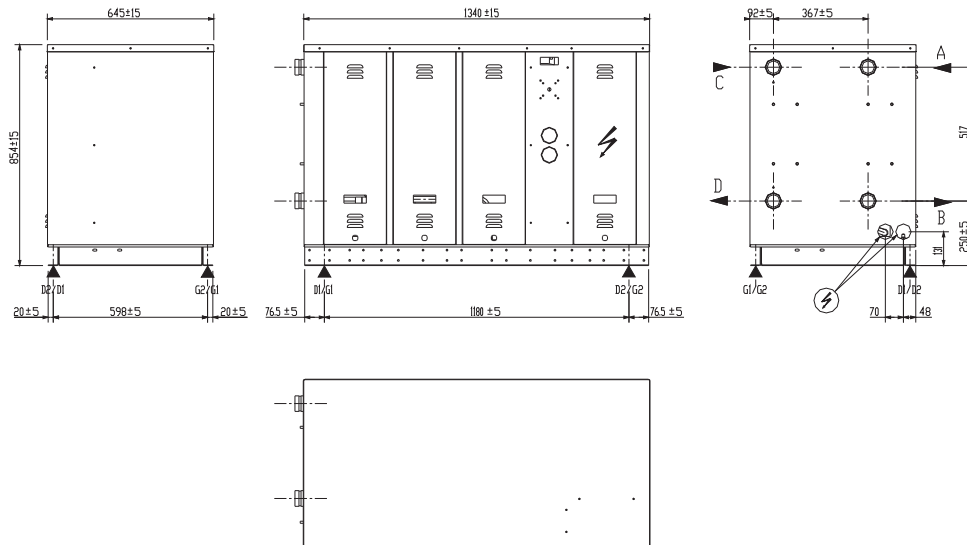

Option Rubber Antivibration Mounts



Hydrolean SWC	050	065	080	090	100
Rubber Mounts Type	APK80/75Sh A		APK100/60Sh A		
Number/machine	4		4		
Height (C) mm	27		27		
Thread dia (E) mm	M8		M10		
Max. Thread Length mm	12.8		10		

B BOX

Indice	DATE	NOM	MODIFICATIONS

MECHANICAL DATA

3

HYDROLEAN™ 120 135 165

Load Distribution
(Kg - Operating weights)

SWC		SWH		SWR	
G1	G2	G1	G2	G1	G2
120	172	120	174	120	160
135	190	135	192	135	173
165	201	165	203	165	184
D1	D2	D1	D2	D1	D2
120	172	120	174	120	160
135	190	135	192	135	173
165	201	165	203	165	184

Piping - C BOX (120/135/165)

	SWC/SWH	SWR
EVAPORATOR	All Units	All Units
Inlet Water (A)	2" - DN50	2" - DN50
Outlet Water (B)	2" - DN50	2" - DN50
CONDENSER	All Units	All Units
Inlet Water (C)	2" - DN50	
Liquid Line C1&C2 (D)		7/8"
Outlet Water (D)	2" - DN50	
Discharge Line C1 (E)		1"3/8
Discharge Line C2 (C)		1"3/8

Clearances

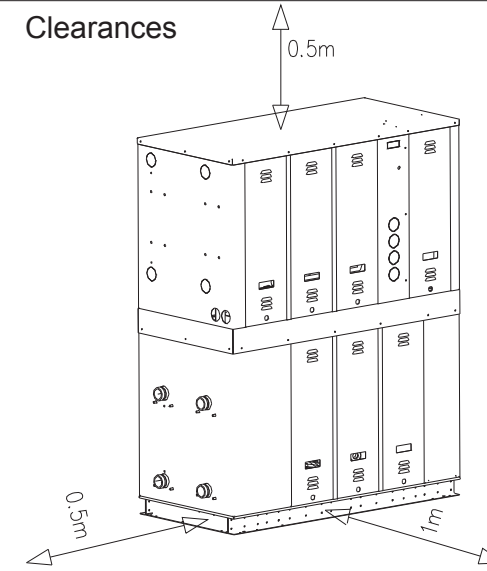

Dimensional Data

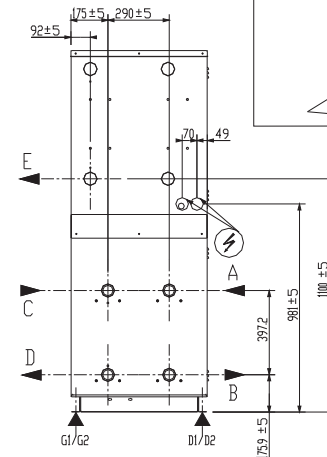
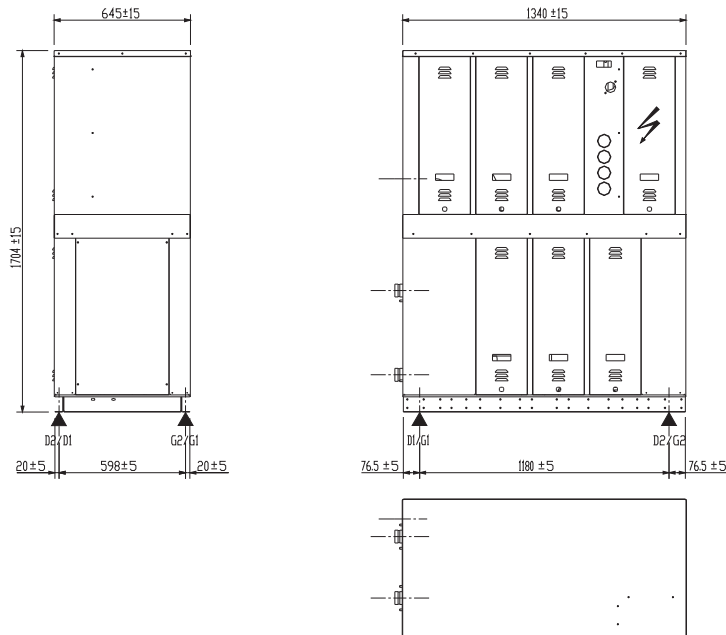

Option Rubber Antivibration Mounts



Hydrolean SWC	120	135	165
Rubber Mounts Type	APK100/75Sh A		
Number/machine	4		
Height (C) mm	27		
Thread dia (E) mm	M10		
Max. Thread Length mm	10		

C BOX

Indice	DATE	NOM	MODIFICATIONS

MECHANICAL DATA

3

MWC 180

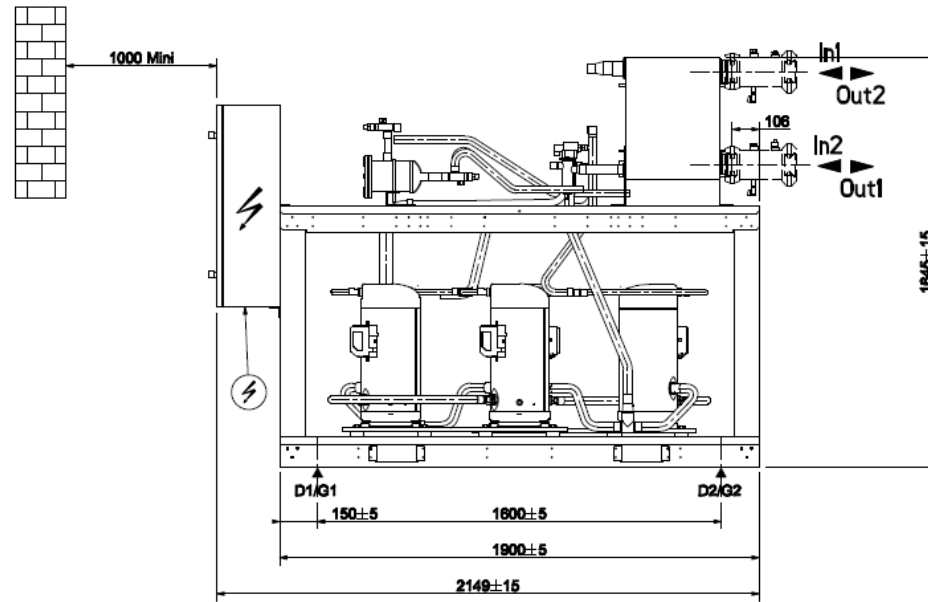
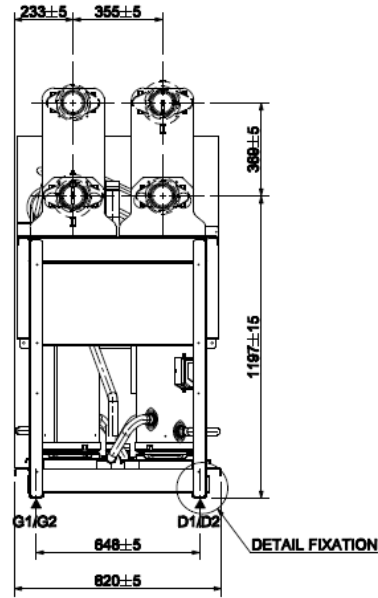

In / Out = \varnothing 4" Victaulic

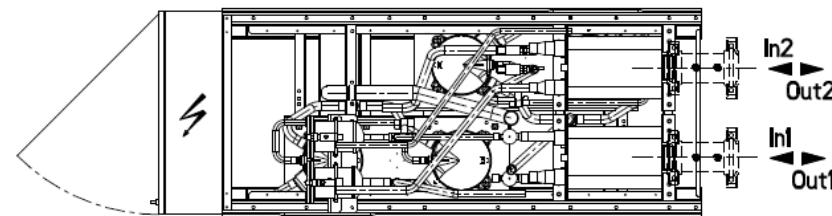
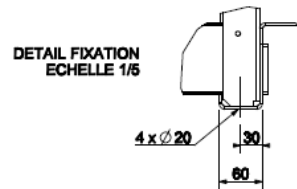

MWC 230-380

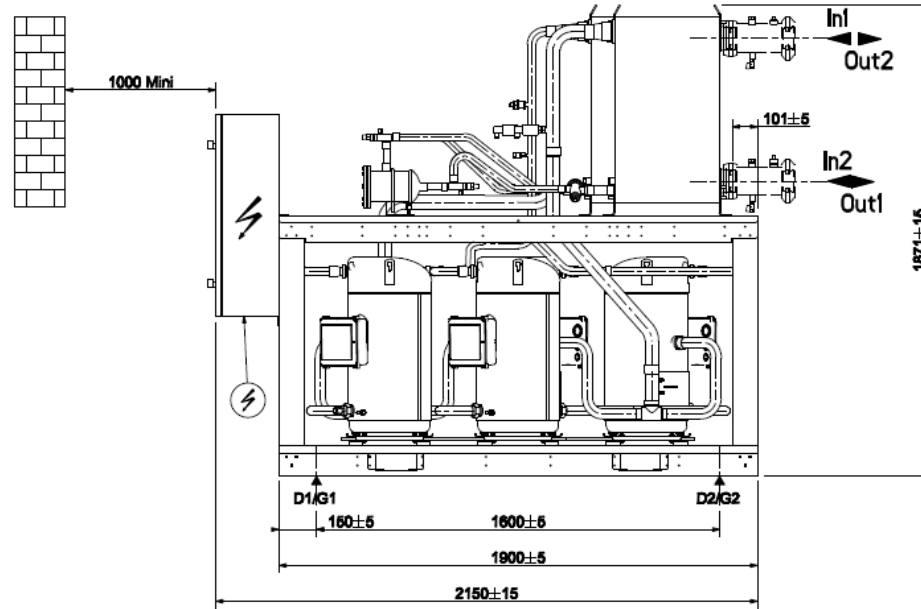
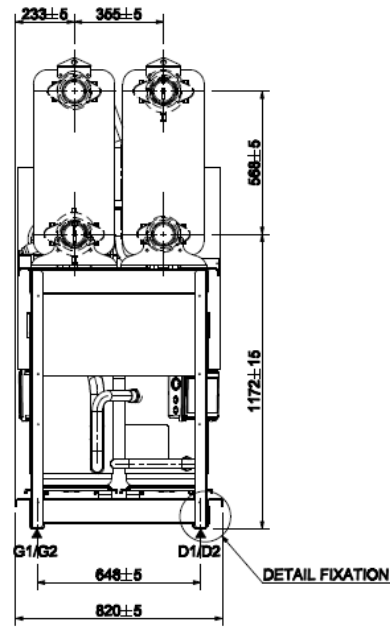

In / Out = \varnothing 4" Victaulic

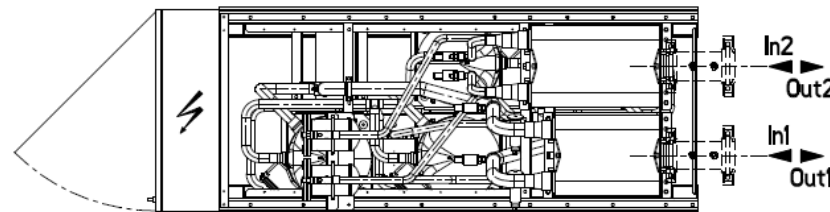
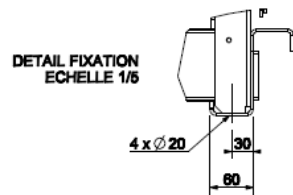

MWC 450-570

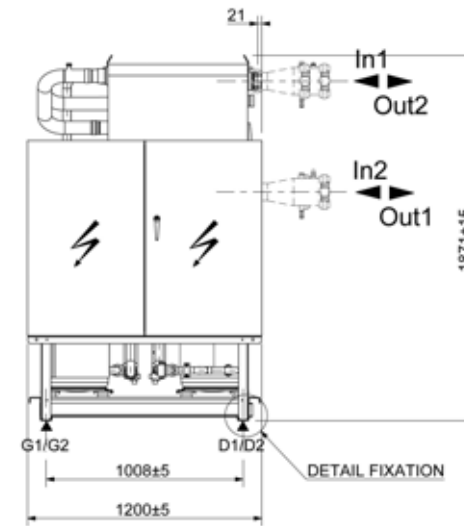
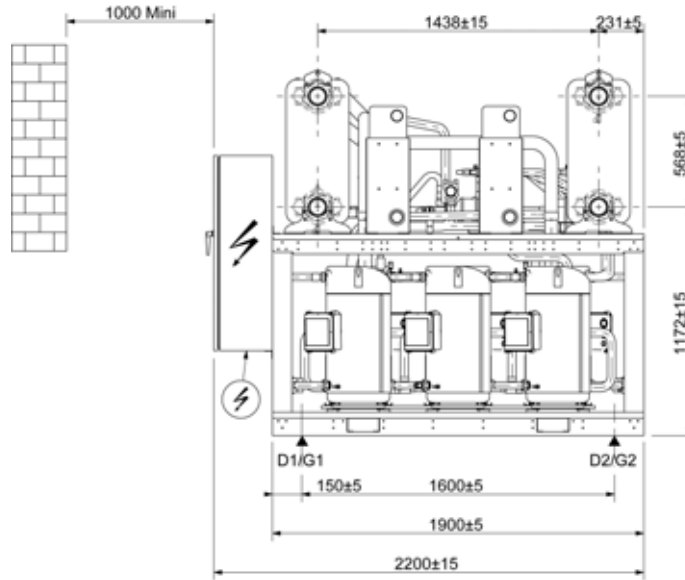

In / Out = \varnothing 5" Victaulic

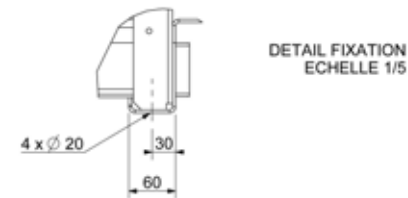
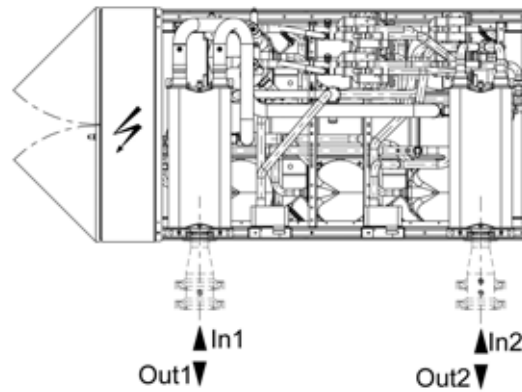

MWC 650-720

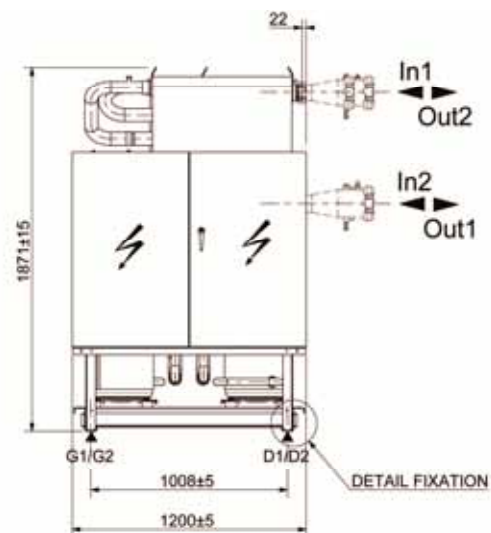
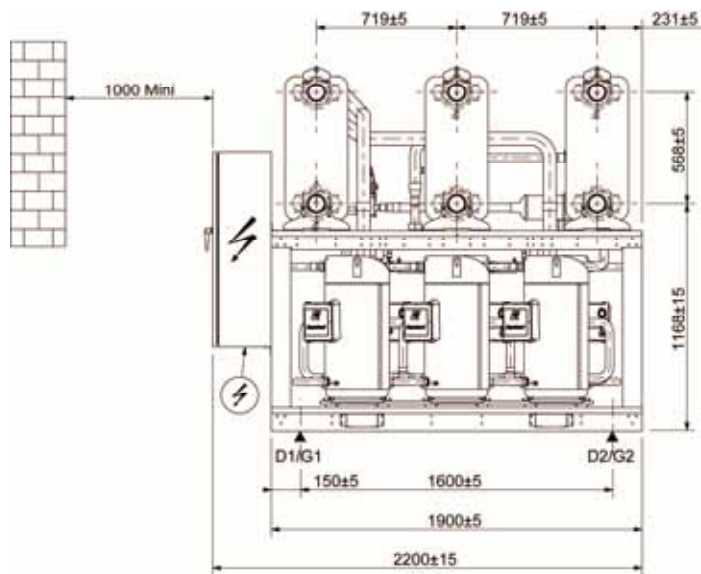

In / Out = \varnothing 5" Victaulic

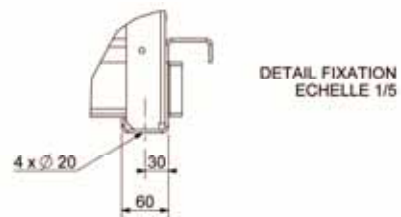
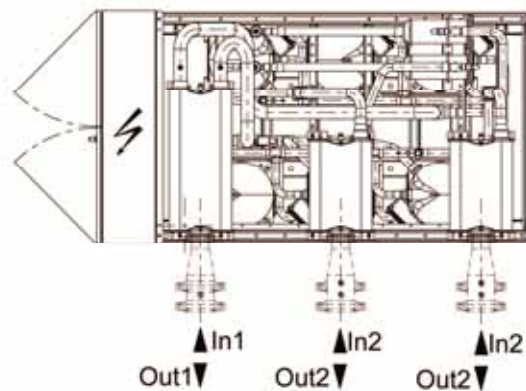

MRC 180

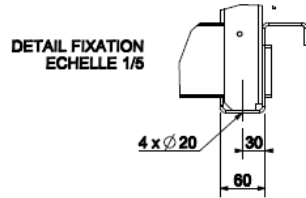
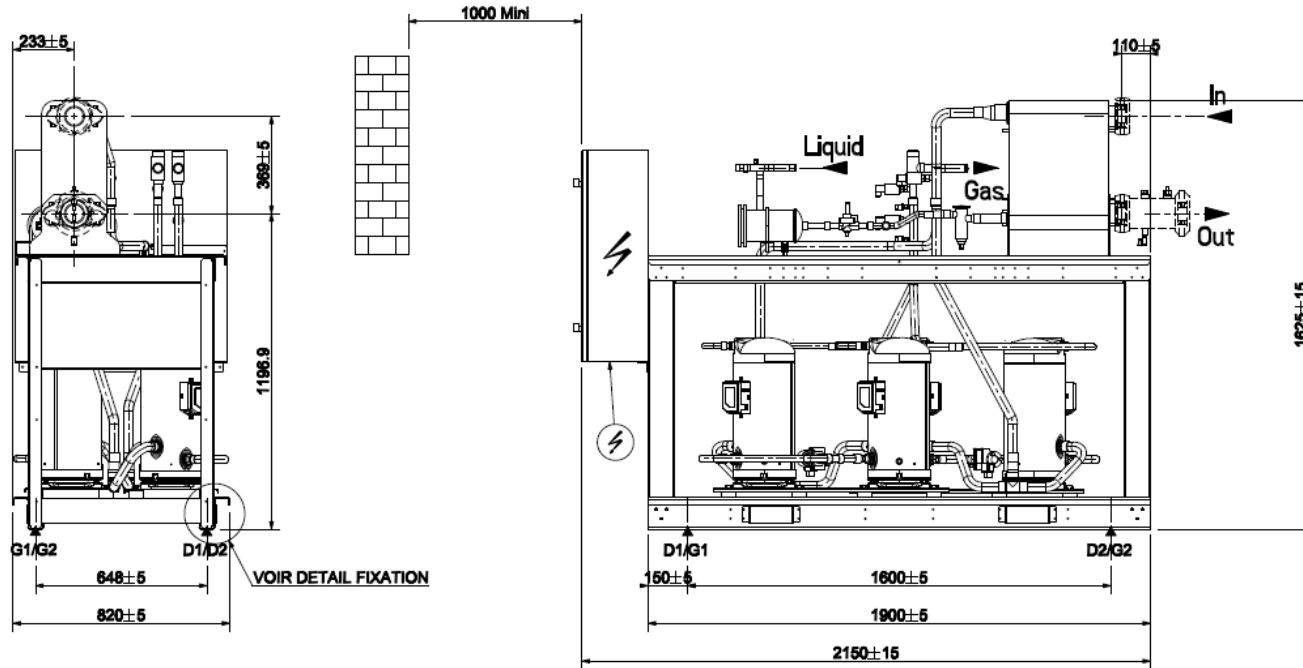

In / Out = \varnothing 4" Victaulic
 Gas = \varnothing 1" 1/8
 Liquid = \varnothing 7/8"

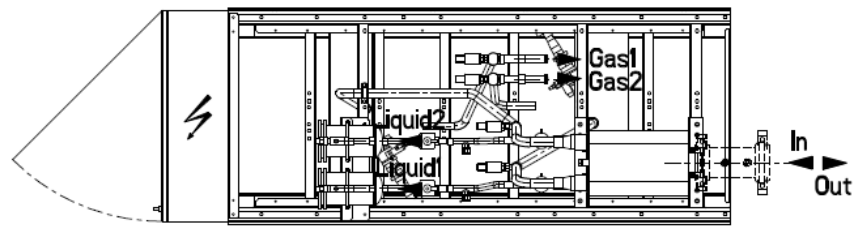

MRC 230-380

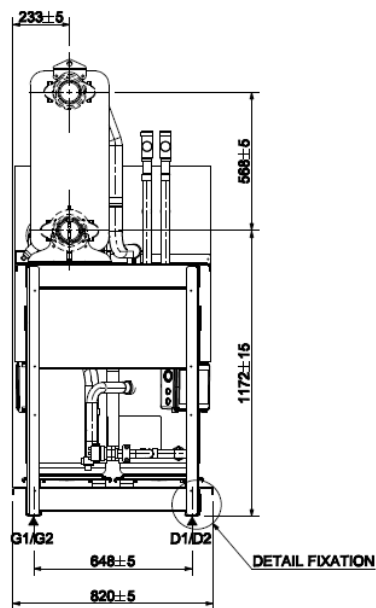

1000 Mini

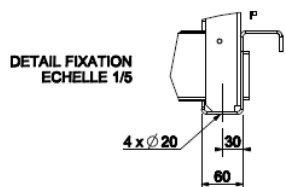
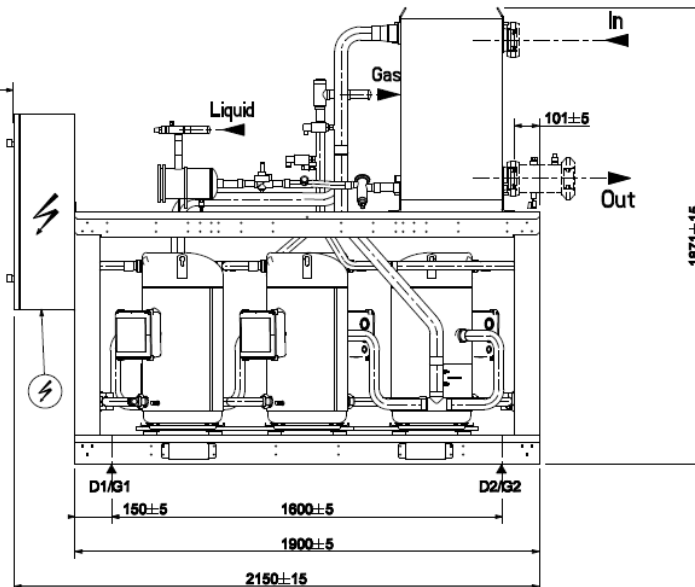

MRC 230	Ø 4" Victaulic	Ø 1"1/8	Ø 7/8"	Ø 1"3/8	Ø 1"1/8
MRC 280 / 330 / 380			Ø 1"1/8		Ø 1"3/8
	In / Out	Liquid1	Liquid2	Gas1	Gas2

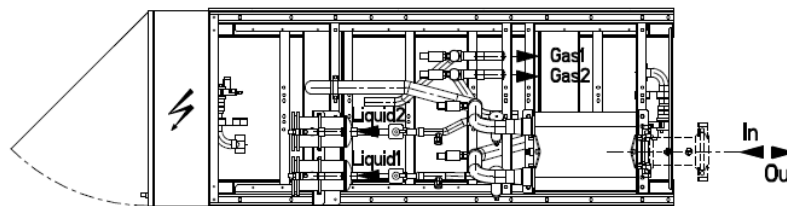

MRC 450-720

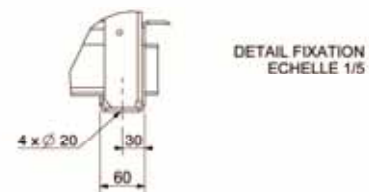
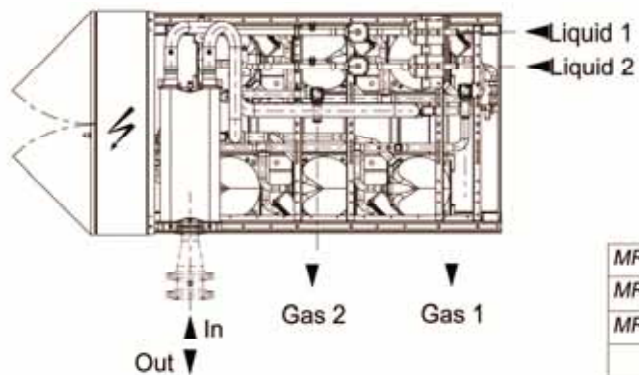
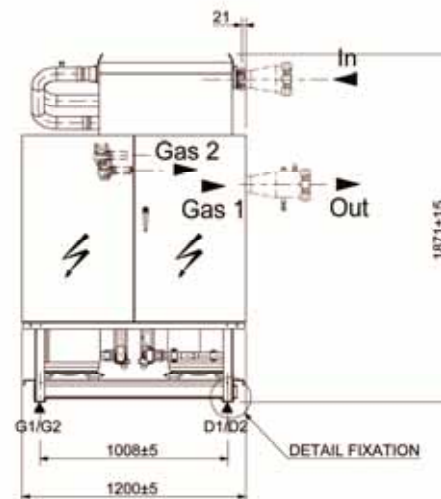
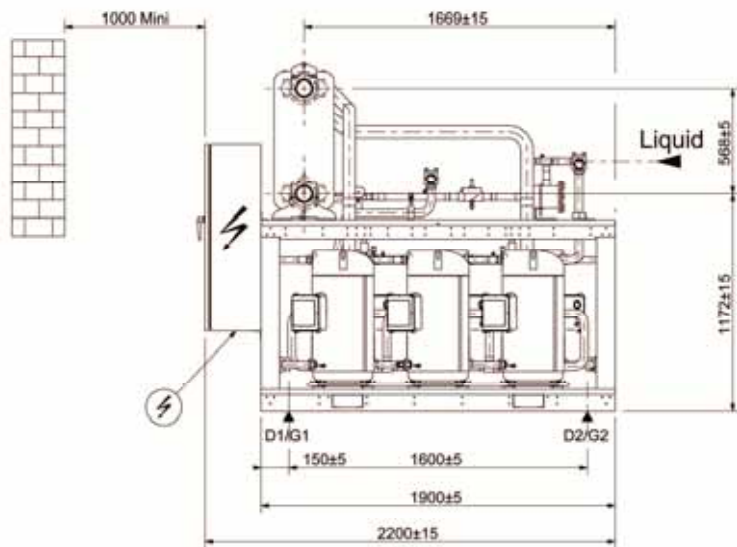

MRC 720	Ø 5" Vicaltic	Ø 1 5/8		Ø 2 1/8	
MRC 650		Ø 1 5/8	Ø 1 3/8	Ø 2 1/8	Ø 1 5/8
MRC 450 / 510 / 570		Ø 1 3/8		Ø 1 5/8	
	In / Out	Liquid1	Liquid2	Gas1	Gas2

APPENDIX 6: PRESSURE DROPS

HYDROLEAN™

HYDROLEAN™	020	025	035	040	050	065
Evaporator curve	A1	A1	A2	A3	B1	B2
Filter evaporator curve	X	X	X	X	Y	Y
Condenser curve	A1	A1	A2	A3	B1	B2
Filter condenser curve	X	X	X	X	Y	Y
Pressure regulated valve	WVFX20	WVFX20	WVFX20	WVFX20	WVFX25	WVFX25
HYDROLEAN™	080	090	100	120	135	165
Evaporator curve	B2	B3	B3	C1	C2	C2
Filter evaporator curve	Y	Y	Z	Z	Z	Z
Condenser curve	B2	B3	B3	C1	C2	C2
Filter condenser curve	Y	Y	Z	Z	Z	Z
Pressure regulated valve	WVFX32	WVFX32	WVFX32	2xWVFX32	2xWVFX32	2xWVFX32

PRESSURE DROP OF HYDROLEAN™ PLATE HEAT EXCHANGERS WITH CLEAR WATER

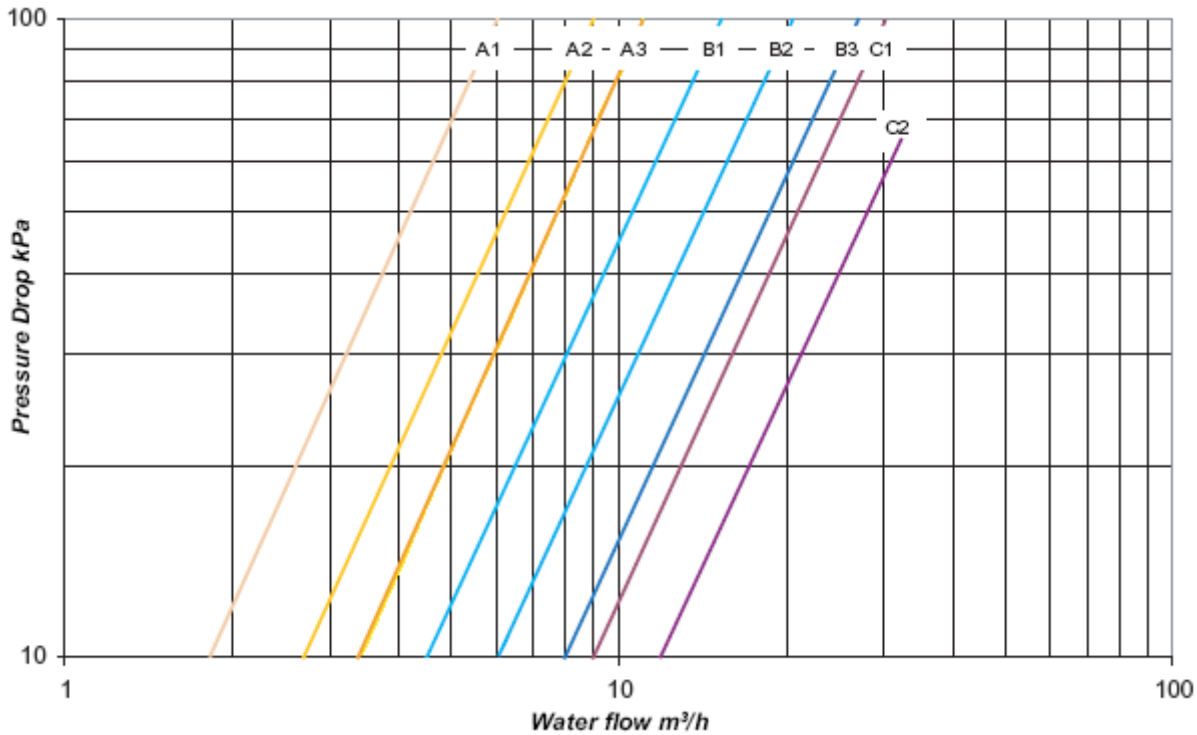

PRESSURE DROP OF HYDROLEAN™ PLATE HEAT EXCHANGERS WITH WATER AND ETHYLENE GLYCOL 30%

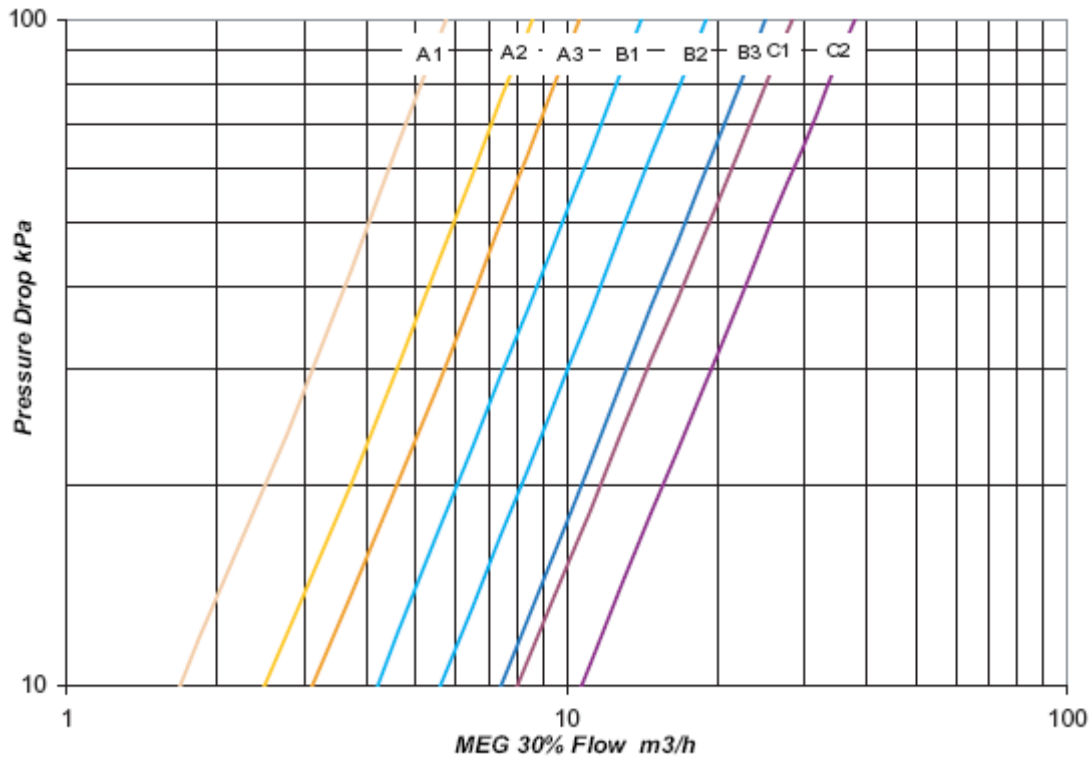

FILTERS PRESSURE DROP

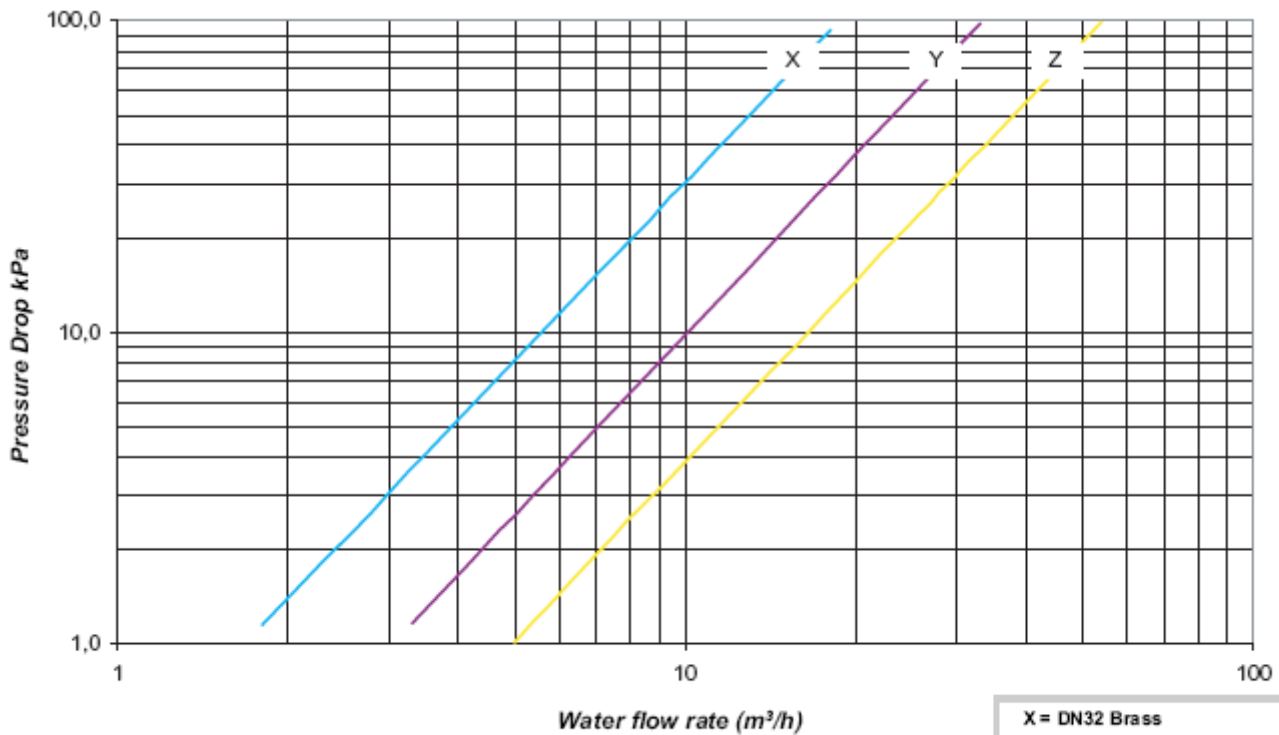

PRESSURE DROP OF PRESSOATIC CONTROL WATER VALVE «FULLY OPEN»

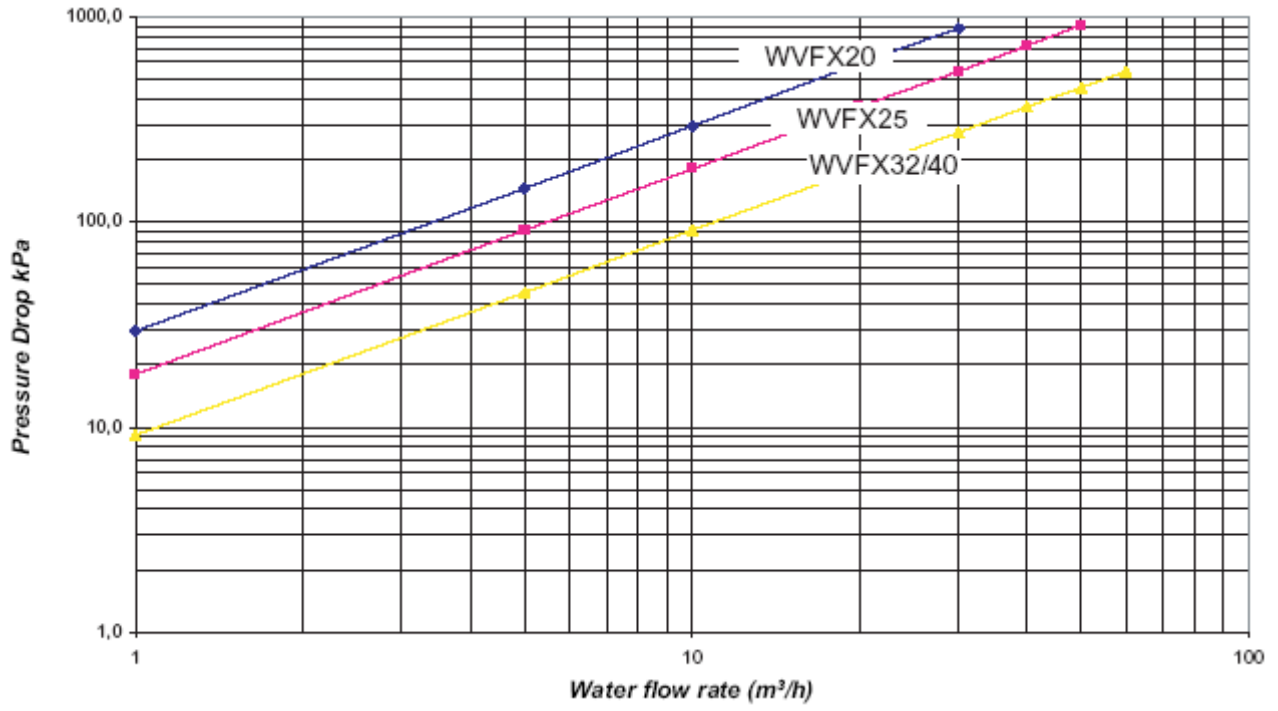

MWC™

EVAPORATORS CURVE

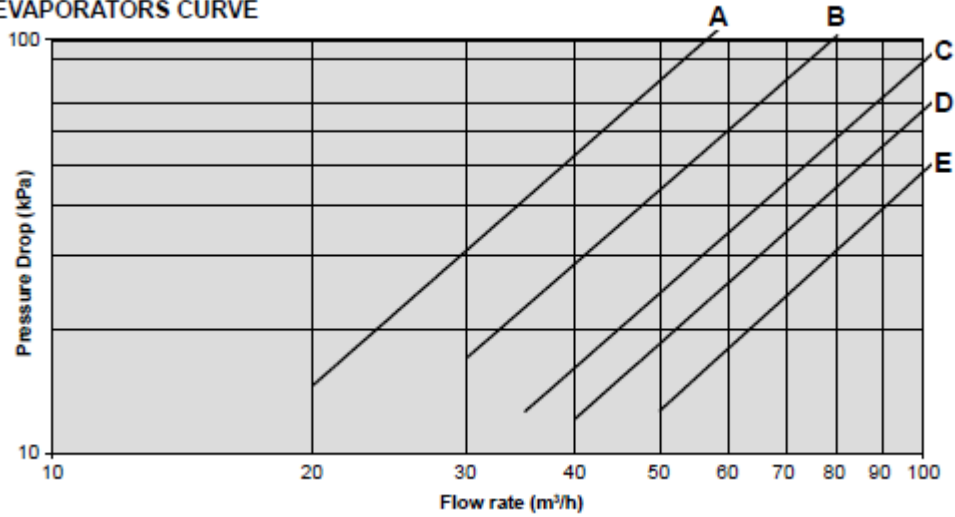

CONDENSER CURVE

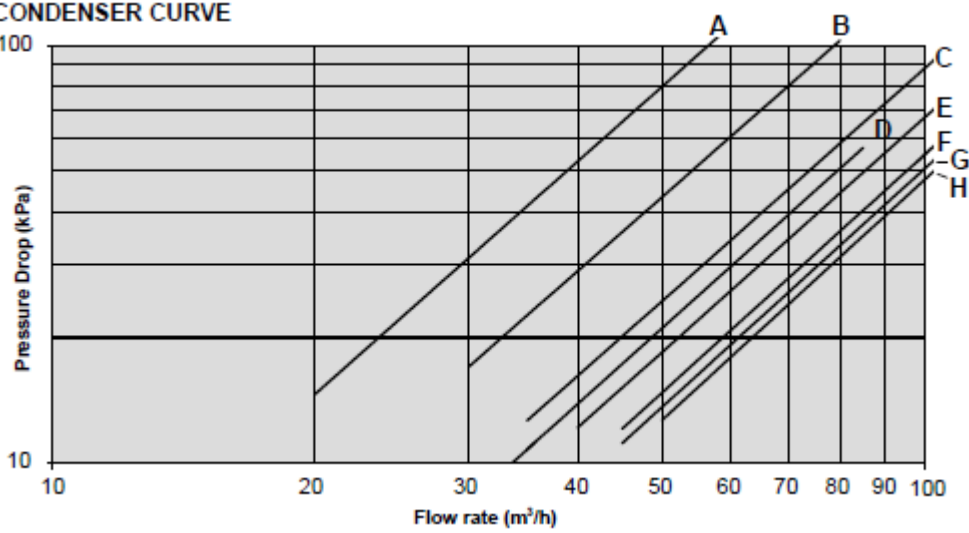

FILTER CURVE

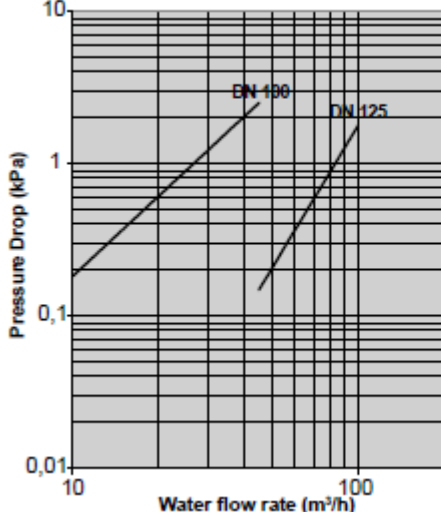

MWC	Curves		
	Evaporator	Condenser	Filter
180	A	A	DN100
230	B	B	DN100
280	B	C	DN100
330	C	C	DN100
380	C	D	DN100
450	D	E	DN125
510	D	F	DN125
570	E	G	DN125
650	E	H	DN125
720	E	H	DN125

Pressure drops are given for information only. A tolerance of +/- 20kPa must be considered when selecting water pumps.

CERTIFICATES – ISO 9001 : 2000



Certificat

Certificate

N° 2007/28674b

AFNOR Certification certifie que le système de management mis en place par :
 AFNOR Certification certifies that the management system implemented by:

LENNOX FRANCE - DIVISION DE LGL FRANCE

pour les activités suivantes :
 for the following activities:

FABRICATION ET CESSION INTERNE DE BIENS D'EQUIPEMENTS
 DESTINES AU CHAUFFAGE, AU CONDITIONNEMENT D'AIR,
 A LA REFRIGERATION ET A LA CLIMATISATION.

MANUFACTURING AND INTERNAL TRANSFER OF EQUIPMENT
 FOR HEATING, VENTILATION, REFRIGERATION AND AIR CONDITIONING.

a été évalué et jugé conforme aux exigences requises par :
 has been assessed and found to meet the requirements of:

ISO 14001 : 2004

et est déployé sur les sites suivants :
 and is developed on the following locations:

2, rue Lavoisier ZI de Longvic BP 60 FR-21602 LONGVIC CEDEX
 ZI Les Meurières BP 71 FR-69780 MIONS

Ce certificat est valable à compter du (année/mois/jour)
 This certificate is valid from (year/month/day)

2010-06-21

Jusqu'au*
 Until*

2012-04-19

Directrice Générale d'AFNOR Certification

Managing Director of AFNOR Certification



F. MÉAUX

Les informations relatives aux AFNOR Certification et ses sites web indiquées ci-dessus sont à titre indicatif. Seul le présent document est valide. Veuillez consulter le site internet de AFNOR Certification pour plus d'informations. This document is for information purposes only. For up-to-date information, the only official source is the certificate holder at <http://www.afnor.org>. AFNOR Certification complies with the international accreditation standards in force (recognition scope available on request).

*Sauf suspension notifiée écrite temps par AFNOR Certification à l'adresse désignée ci-dessus. Le présent document n'a qu'une valeur indicative. Seul le présent document est valide. Veuillez consulter le site internet de AFNOR Certification pour plus d'informations. This document is for information purposes only. For up-to-date information, the only official source is the certificate holder at <http://www.afnor.org>. AFNOR Certification complies with the international accreditation standards in force (recognition scope available on request).

CERTIFICATES – PED

Bureau Veritas S.A. is a Notified



Body under the number 0062

**BUREAU
VERITAS**

ATTESTATION D'APPROBATION DE SYSTEME DE QUALITE (module H1)
CERTIFICATE OF QUALITY SYSTEM APPROVAL (module H1)
N° CE-PED-H1- LEN001-02-FRA

BUREAU VERITAS S.A., agissant dans le cadre de sa notification (numéro d'organisme notifié 0062), atteste que le système de qualité appliqué par le fabricant pour la conception, la fabrication, l'inspection finale et les essais des équipements sous pression identifiés ci-après, a été examiné selon les prescriptions du module H1 de l'annexe III de la directive "Equipements sous pression" N° 97/23/CE et est conforme aux dispositions correspondantes de la directive.

BUREAU VERITAS S.A., acting within the scope of its notification (notified body number 0062), attests that the quality system operated by the manufacturer for design, manufacture, final inspection and testing of the pressure equipment identified hereunder has been examined against the provisions of annex III, module H1, of the Pressure Equipment directive n° 97/23/EC, and found to satisfy the provisions of the directive which apply to it.

Fabricant (nom) / Manufacturer (name): **LENNOX – France Usine de MIONS**

Adresse / Address: **Z.I. Les Meurières – BP 71 – F. 69780 - MIONS**

Marque commerciale / Trade mark: **LENNOX**

Description des équipements: **Ensemble sous pression**
Equipment description:

Identification des équipements concernés (liste en annexe le cas échéant) : **Suivant liste en annexe**
Identification of equipment concerned (list attached where necessary):

Numéro(s) d'attestation(s) d'examen CE de la conception émise(s), dans le cadre de l'application du module H1, par BUREAU VERITAS S.A. (organisme notifié n° 0062), concernée(s) par l'approbation du système de qualité:
Number(s) of the EC design-examination certificate(s) issued under the scope of module H1, by BUREAU VERITAS S.A. (notified body nr 0062), concerned by the approval of the quality system:

Cette attestation est valable jusqu'au **02/09/2005**
This certificate is valid until....

Le maintien de l'approbation est soumis à la réalisation par le Bureau Veritas des audits, essais et vérifications selon le contrat signé par le fabricant et le Bureau Veritas.
The approval is conditional upon the surveillance audits, tests and verifications to be carried out by Bureau Veritas, as per the provisions stated in the agreement signed by both the manufacturer and Bureau Veritas.

Cette attestation est présumée nulle et le fabricant supportera seul les conséquences de son utilisation, si les assurances - données par le fabricant lors de la demande d'intervention - en matière (a) d'application de son système qualité approuvé, (b) de conformité de son équipement à son approbation CE de la conception et (c) d'inspection et d'essais des produits finis se révèlent inexacts et, de manière générale, si le fabricant ne respecte pas l'une ou l'autre des obligations mises à sa charge par la directive n° 97/23/CE du 29 mai 1997 telle que transposée dans le(s) droit(s) national(aux) applicable(s).

This certificate shall be deemed to be void and the manufacturer shall alone bear any consequences pursuant to its use, where the manufacturer fails to comply with his undertakings as per the agreement in respect of (a) implementation of the approved quality system, (b) conformity of the equipment with the EC design-approval conditions and (c) inspection and tests on the final product, and generally where the manufacturer fails in particular to comply with any of his obligations under directive nr 97/23/EC of 29 may 1997 as transposed in the applicable law(s).

Etabli à / Made at	Le / On	Signé par / Signed by	Signature / Signature
LYON/DARDILLY	02 SEPTEMBRE 2002	P.BERIOU	
Code d'enregistrement / Registration code: 2002/3948/P			

La présente attestation est soumise aux Conditions Générales de Service de Bureau Veritas jointes à la demande d'intervention signée par le demandeur.
This certificate is subject to the terms of Bureau Veritas General Conditions of Service attached to the agreement signed by the applicant.

CERTIFICATES – DECLARATION OF CE CONFORMITY



Site Industriel de LONGVIC
ZI de LONGVIC – BP 60
21602 LONGVIC – France

Téléphone : +33 (0)3 80 77 41 41
Fax : +33 (0)3 80 66 66 35

Site industriel de MIONS
ZI Les MEURIERES – BP71
69780 MIONS

Téléphone : +33 (0)4 72 23 20 20
Fax : +33 (0) 4 78 20 07 76

DECLARATION DE CONFORMITE DU CONSTRUCTEUR
Conformément
à la Directive européenne « Equipement sous pression » 97/23/CE,

CE CONFORMITY DECLARATION
As defined by
« Pressure equipment » Directive 97/23/EC »

LGL France SA, ZI Les Meurières – 69780 Mions – France

La société soussignée certifie sous sa seule responsabilité que les fabrications de roof top et Chiller (ensembles sous pression) désignés par les types suivants :

The company hereby declare, under its own responsibility, that roof top and chiller (pressure equipment constituting the assembly) which are designated by :

ROOFTOP du type BALTIC à condensation à air de 22 à 85 KW BAC, BAH, BAM, BAG, BCK, BHK, BGK, BDK BWH, BWM, Taille 045-055-065-075	CHILLER du type NEOSYS de 200 Kw à 1080 kW NAC de la taille 200 à 1080 kW NAH de la taille 200 à 480 Kw
ROOFTOP du type FLEXY de 80 à 200 KW FCM, FHM, FGM, FDM FWH, FWM, FGM, FDM Taille 085 à 230	CHILLER du type MWC de 200 Kw à 700 kW MWC de la taille 180 à 720 kW MRC de la taille 180 à 720 kW
ROOFTOP du type FXK Taille 025 à 170	CHILLER du type Hydrolean de 20 Kw à 165 kW SWC de la taille 20 à 165 kW SWR de la taille 20 à 165 kW SWH de la taille 20 à 165 kW

Qui contiennent des fluides frigorigènes classés en groupe 2 (R407C ou R410A),
Which are containing refrigerating fluids classified in group 2 (R407C or R410A),

1. Sont conformes aux dispositions de la Directive « Equipements sous pression », 97/23/CE
Is in compliance with the requirements of « Under pressure equipments » directive, 97/23/EC :

Module d'évaluation *Evaluation Module* : H
CE- PED- H- LGL- 001-11- FRA
Catégorie ; I , II et III

Organisme notifié *Notified body* : Bureau VERITAS (CE0062)
67-71 Boulevard du château 92571 Neuilly sur Seine.

2. Sont conformes aux dispositions de la Norme EN 378
Are in compliance with the requirements of EN 378
3. Sont conformes aux dispositions de la Directive - *Are in compliance with the requirements of*
- « Machines », 2006/42/CE - « Machinery », 2006/42/EC
 - « CEM », 2004/108/CEE - « EMC », 2004/108/EEC
 - « Appareils à gaz », 90/396/CEE modifiée - « Gas machines », 90/396/EEC amended
 - « Basse Tension » 2006/95/CE, « Low voltage », 2006/95/EC

Ces produits sont fournis avec un marquage de conformité.
The products are provided with a marking of conformity.



Date : 14 avril 2011
Vincent Heydecker
Directeur des opérations Europe
European Operation Director

LENNOX France, Division climatisation de LGL France

Siège social : LGL France – ZI « Les Meurières » - BP71 – 69780 MIONS – France
Société anonyme au capital de 309.615.120F – RCS LYON B 309 528 115 – N° IDENTIFICATION TVA FR 59 309 528 115 – APE 292F

www.lennox europe.com

SALES OFFICES :

BELGIUM AND LUXEMBOURG

☎ + 32 3 633 3045

RUSSIA

☎ +7 495 626 56 53

FRANCE

☎ +33 1 64 76 23 23

SPAIN

☎ +34 902 533 920

GERMANY

☎ +49 (0) 6071 3915919

UKRAINE

☎ +380 44 461 87 79

ITALY

☎ + 39 02 495 26 200

UNITED KINGDOM AND IRELAND

☎ +44 1604 669 100

NETHERLANDS

☎ + 31 332 471 800

POLAND

☎ +48 22 58 48 610

OTHER COUNTRIES :

PORTUGAL

☎ +351 229 066 050

LENNOX DISTRIBUTION

☎ +33 4 72 23 20 00



WC_CHILLER-IOM-1011-E

Due to Lennox's ongoing commitment to quality, the specifications, ratings and dimensions are subject to change without notice and without incurring liability. Improper installation, adjustment, alteration, service or maintenance can cause property damage or personal injury. Installation and service must be performed by a qualified installer and servicing agency