

Installation, operating and maintenance

FLATAIR R410A FMC-H/ FIC-H/ FSC-H

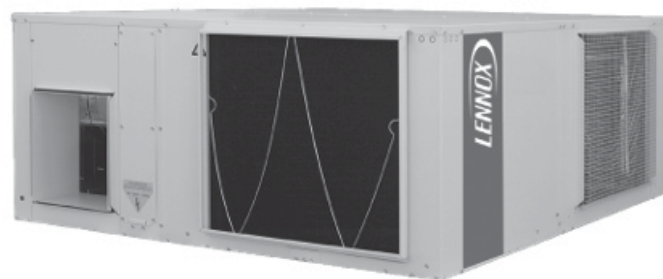

- Providing indoor climate comfort



WARNING: Read this manual before installation, reparation o maintenance works.

TABLE OF CONTENTS

POINTS TO BEAR IN MIND	PAGE 2
DATA PAGE FOR COMMISSIONING UNIT	PAGE 3
1.- GENERAL CHARACTERISTICS	PAGE
1.1.- PHYSICAL DATA	4
1.2.- ELECTRICAL DATA	4-5
1.3.- OPERATING LIMITS	5
1.4.- FAN PERFORMANCES	6
1.5.- PIPING DRAWINGS	7-8
1.6.- UNIT DIMENSIONS	9-14
1.7.- DUCT POSITION	15
2.- INSTALLATION	PAGE
2.1.- PRELIMINARY PREPARATIONS	16
2.2.- UNIT ACCEPTANCE	16
2.3.- OPTIONAL OPERATIONS PRIOR TO UNIT INSTALATION	18
2.4.- UNIT LOCATION	18
2.5.- INSTALLATION CLEARANCES	18
2.6.- DRAINS	19-20
2.7.- REFRIGERANT CONNECTIONS	21
2.8.- ELECTRICAL CONNECTIONS	
3.- COMMISSIONING AND OPERATION	PAGE
3.1.- PRELIMINARY CHECKS	22
3.2.- PRELIMINARY CHECKS AT FIRST INSTALLATION	22-23
4.- MAINTENANCE	PAGE
4.1.- PREVENTIVE MAINTENANCE	24
4.2.- CORRECTIVE MAINTENANCE	24-25
4.3.- FAILURE DIAGNOSIS	26
4.4.- REGULATION	27

Lennox have been providing environmental solutions since 1895, our COMPACTAIR range continues to meet the standards that have made LENNOX a household name. Flexible design solutions to meet YOUR needs and uncompromising attention to detail. Engineered to last, simple to maintain and Quality that comes as standard. For information on local contacts at www.lennox europe.com.

All the technical and technological information contained in this manual, including any drawing and technical descriptions provided by us, remain the property of Lennox and must not be used (except in the operation of this product), reproduced, issued to or made available to third parties without the prior written agreement of Lennox.

DANGER AND WARNING SIGNS



Abrasive surfaces



Low temperatures



High temperatures

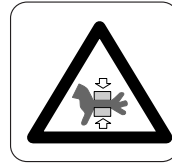

Risk of injury by moving objects

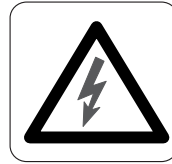

Electrical voltage



Risk of injury by rotating objects

ELECTRICAL CONNECTIONS



Make sure to switch off the power before installing, repairing or carrying out maintenance on the unit, in order to prevent serious electrical injury.

Keep local and national legislation in mind when installing the unit.

Standard Guidelines to Lennox equipment

All technical data contained in these operating instructions, including the diagrams and technical description remains the property of Lennox and may not be used (except for the purpose of familiarizing the user with the equipment), reproduced, photocopied, transferred or transmitted to third parties without prior written authorization from Lennox.

The data published in the operating instructions is based on the latest information available. We reserve the right to make modifications without notice.

We reserve the right to modify our products without notice without obligation to modify previously supplied goods.

These operating instructions contain useful and important information for the smooth operation and maintenance of your equipment.

The instructions also include guidelines on how to avoid accidents and serious damage before commissioning the equipment and during its operation and how to ensure smooth and fault-free operation. Read the operating instructions carefully before starting the equipment, familiarize yourself with the equipment and handling of the installation and carefully follow the instructions. It is very important to be properly trained in handling the equipment. These operating instructions must be kept in a safe place near the equipment.

Like most equipment, the unit requires regular maintenance. This section concerns maintenance and management personnel.

If you have any queries or would like to receive further information on any aspect relating to your equipment, do not hesitate to contact us.

DATA PAGE FOR UNIT COMMISSIONING

UNIT: _____ SERIAL Nr: _____

CONTROL PANEL IDENTIFICATION CODE: _____

INSTALLATION ADDRESS: _____

INSTALLER: _____ INSTALLER TEL: _____

INSTALLER ADDRESS: _____

DATE OF COMMISSIONING: _____

CHECKS:

SUPPLY VOLTAGE: _____ RATED VOLTAGE OF THE UNIT: _____

YES NO

- UNIT ON SHOCK ABSORBERS YES NO
- DRAINAGE WITH TRAP YES NO
- MAIN POWER SUPPLY CONNECTION YES NO
- CONTROL PANEL CONNECTION YES NO
- COMPRESSOR OIL LEVEL INDICATOR YES NO

DATA INPUT:

COOLING CYCLE

HEATING CYCLE

Air intake temperature to the outdoor coil: < 1 ___ °C / 2 ___ °C

Air intake temperature to the outdoor coil: < 1 ___ °C / 2 ___ °C

Air output temperature to the outdoor coil: < 1 ___ °C / 2 ___ °C

Air output temperature to the outdoor coil: < 1 ___ °C / 2 ___ °C

High pressure: < circuit 1 _____ / circuit 2 _____

High pressure: < circuit 1 _____ / circuit 2 _____

Low pressure: < circuit 1 _____ / circuit 2 _____

Low pressure: < circuit 1 _____ / circuit 2 _____

ELECTRIC POWER CONSUMPTION (Amps)

Compressor 1 ___/___/___ Compressor 2 ___/___/___

Compressor 1 ___/___/___ Compressor 2 ___/___/___

Compressor 3 ___/___/___

Compressor 3 ___/___/___

Outdoor fan section 1 ___/___/___

Outdoor fan section 1 ___/___/___

Outdoor fan section 2 ___/___/___

Outdoor fan section 2 ___/___/___

Options installed: _____

Comments: _____

1.- GENERAL CHARACTERISTICS

1.1.- PHYSICAL DATA

F	M	C	015	S	N	M	1	M
Unit FLATAIR		C: Cooling only H: Heat pump X: Cooling only / Heat pump	Approximate cooling capacity in kW	S: One Circuit	---	Type of refrigerant M: R-410A	Number of revision	M: 400V/3/50
	M: Compact unit S: Outdoor unit I: Indoor unit							



FMC: Cooling only unit R-410A.
FMH: Heat pump unit R-410A.

WEIGHTS OF THE UNITS AND OPTIONS

MODELS		010	012	015	020	025	030
Net weight Kg.	<i>Package unit</i>						
	Cooling only FMC	170	174	250	268	322	338
	Heat pump FMH	175	179	255	273	327	343
	<i>Outdoor unit</i>						
	Cooling only FSC	112	116	165	159	202	208
	Heat pump FSH	117	121	170	164	207	213
	<i>Indoor unit</i>						
	Cooling only FIC	58	58	85	109	121	131
	Heat pump FIH	58	58	85	109	121	131
	<i>Options</i>						
	Free-cooling 1 damper	12	12	12	14	15	15
	Free-cooling 2 dampers	24	24	24	28	30	30
Electrical heater	7	7	7	7	8	8	

1.2.- ELECTRICAL DATA

ELECTRICAL CONSUMPTION

	UNIT	10 230V I	10	12	15	20	25	30
PACKAGE UNIT (INDOOR+ OUTDOOR)	Maximum power (KW)	5,5	5,3	6,6	7,8	10,4	12,6	14,2
	Maximum current (A)	31,7	34,1	39,7	49,0	75,3	82,3	86,9
	Starting current (A)	90,2	34,1	39,7	49,0	75,3	82,3	86,9
INDOOR UNIT	Maximum power (KW)	0,4	0,4	0,4	0,8	1,0	1,3	1,3
	Maximum current (A)	2,6	2,6	2,6	2,8	4,3	4,3	4,3
	Starting current (A)	1,7	1,7	1,7	1,8	2,8	2,8	2,8
OUTDOOR UNIT	Maximum power (KW)	5,1	4,9	6,1	7,0	9,4	11,3	13,0
	Maximum current (A)	29,1	11,1	13,4	15,8	19,3	25,7	26,7
	Starting current (A)	87,6	31,5	37,1	46,2	71,0	78,0	82,6

1.- GENERAL CHARACTERISTICS

1.2.- ELECTRICAL DATA

Electrical consumptions to add to the unit indoor and to the set

ELECTRICAL HEATER		10 230V I	10	12	15	20	25	30
Maximum power (KW)	Standard	3	3	4,5			7,5	
	Medium	6	6	6			9	
	High		9	9			12	
Maximum current (A)	Standard	13,0	7,5	11,3			18,8	
	Medium	26,1	15	15			22,5	
	High	-	22,5	22,5			30	

1.3.- OPERATING LIMITS

OPERATING LIMITS (COOLING ONLY)		MAXIMUM TEMPERATURES	MINIMUM TEMPERATURES
COOLING CYCLE OPERATION	INDOOR TEMPERATURE	32°C BS / 23°C BH	21°C BS / 15°C BH
	OUTDOOR TEMPERATURE	Table 1	+15°C UNIDAD ESTÁNDAR 0°C (*) -15°C (**)

(*) With option kit low temperature 0°C.

(**) With option kit low temperature -15°C.

OPERATING LIMITS (HEAT PUMP)		MAXIMUM TEMPERATURES	MINIMUM TEMPERATURES
COOLING CYCLE OPERATION	INDOOR TEMPERATURE	32°C BS / 23°C BH	21°C BS / 15°C BH
	OUTDOOR TEMPERATURE	Table 1	+15°C STANDARD UNIT 0°C (*) -15°C (**)
HEATING CYCLE OPERATION	INDOOR TEMPERATURE	27°C BS	15°C BS
	OUTDOOR TEMPERATURE	25°C (With 20° indoor temperature. Models 10-15-20-30) 23°C (With 20° indoor temperature. Models 12-25)	-12°C

DB: Dry bulb temperature

WB: Wet bulb temperature

(*) Active CL40 parameter to operate at 0°

(**) With option kit low temperature -15°C.

Table 1	10	12	15	20	25	30
Maximum outdoor temperature	45	43	45	44	44	41

1.- GENERAL CHARACTERISTICS

1.4.- FAN PERFORMANCES INDOOR UNITS

	UNITS	Airflow (m3/h)					
		10	12	15	20	25	30
Available static pressure (Pa)	0	2350	2300	3575	4850	5750	5500
	10	2275	2250	3495	4785	5730	5455
	20	2240	2200	3410	4715	5705	5405
	30	2190	2150	3330	4645	5670	5350
	40	2140	2100	3250	4575	5630	5285
	50	2080	2040	3170	4500	5580	5220
	60	2025	1975	3095	4425	5530	5140
	70	1975	1925	3020	4345	5470	5060
	80	1925	1860	2945	4260	5405	4965
	90	1840	1800	2875	4175	5330	4870
	100	1775	1730	2800	4090	5250	4765
	110	1625	1650	2735	4000	5165	4655
	120	1500		2665	3910	5075	4540
	130			2600	3815	4975	4415
	140			2535	3720	4870	4285
	150			2470	3620	4755	4150
	160			2410	3520	4640	4005
	170				3415	4515	3855
	180				3310	4380	3695
	190				3200	4245	
	200				3090	4100	
	210					3945	
	220					3790	
	230					3625	
240					3455		

OUTDOOR UNITS

	UNITS	Airflow (m3/h)					
		10	12	15	20	25	30
Available static pressure (Pa)	0	3500	3400	4500	5650	6000	5850
	10	3410	3325	4460	5550	5920	5755
	20	3300	3160	4410	5450	5840	5665
	30	3190	3075	4360	5350	5760	5575
	40	3080	2980	4310	5250	5680	5485
	50	2970	2890	4250	5150	5600	5400
	60	2840	2790	4190	5050	5520	5315
	70	2700	2690	4125	4945	5445	5235
	80	2560	2580	4055	4840	5365	5155
	90	2410	2400	3980	4735	5290	5075
	100	2350		3905	4630	5210	5000
	110			3825	4525	5135	
	120			3740	4420	5060	
	130				4315	4985	
	140				4205	4910	
	150				4095	4835	
	160					4760	

 Nominal airflow

1.- GENERAL CHARACTERISTICS

1.8.- PIPING DRAWINGS

COOLING ONLY UNITS 10-12-15

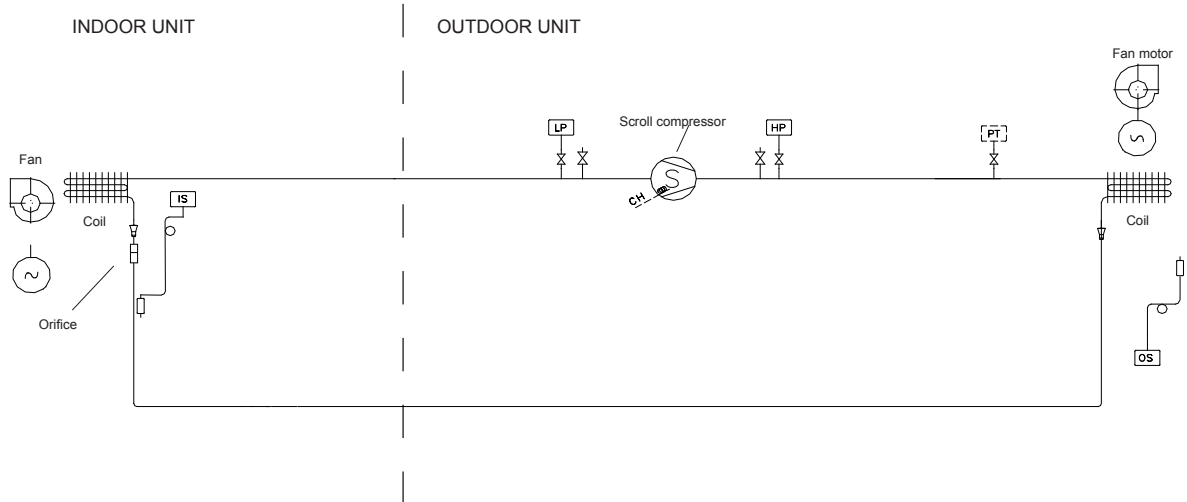

— — OPTION ELEMENT

HEAT PUMP UNITS 10-12-15

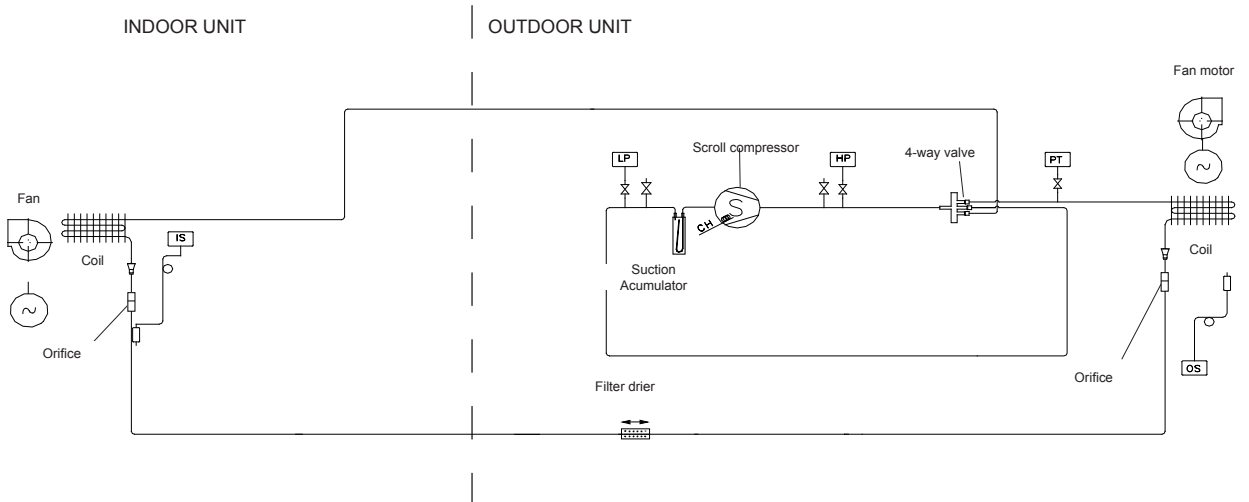

 Pressure gauge. (5/16" to be fitted by the installer).

 Liquid-gas pipe sensor

 Low pressure switch

 High pressure switch

 Crank case heater. (Low ambient 0°C or -15°C option for cooling only units).

 Pressure transducer (Low ambient 0°C or -15°C option for cooling only units).

 Outdoor temperature sensor

1.- GENERAL CHARACTERISTICS

1.8.- PIPING DRAWINGS

HEAT PUMP UNITS 20-25-30

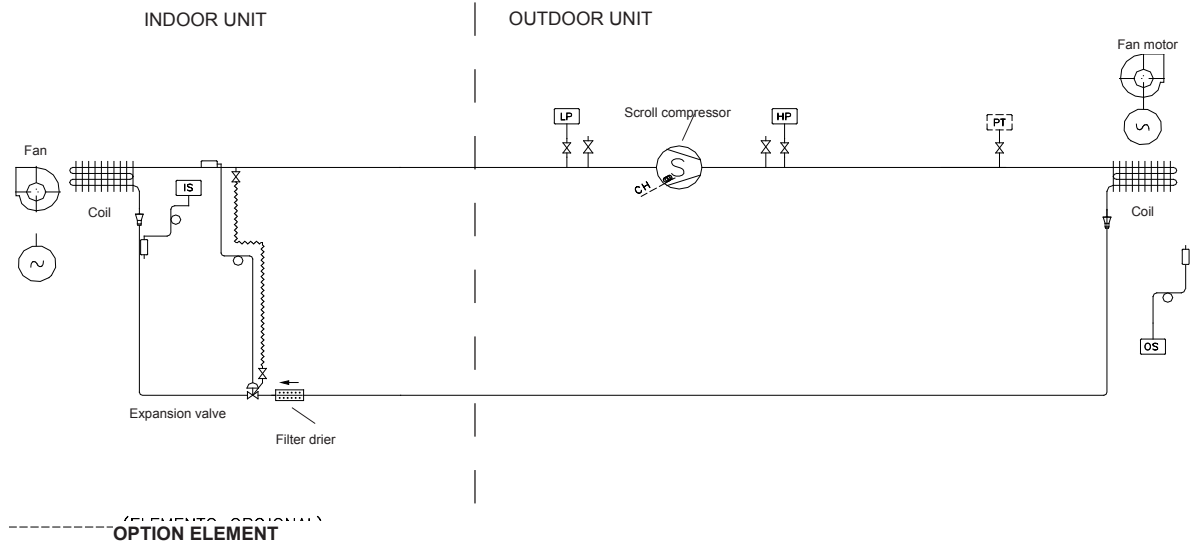

HEAT PUMP UNITS 20-25-30

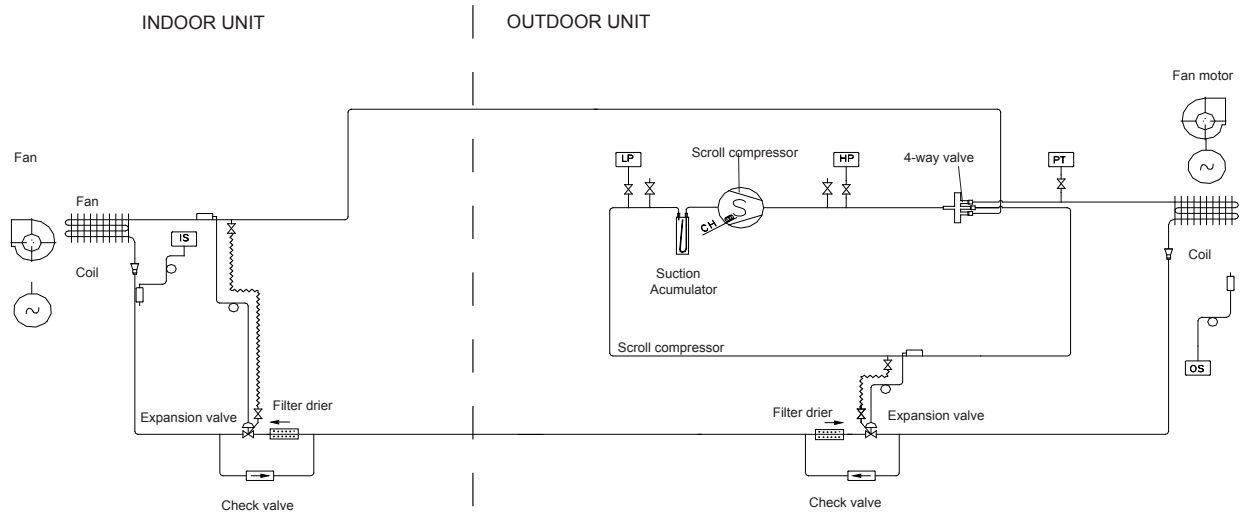

 Pressure gauge. (5/16" to be fitted by the installer).

 Liquid-gas pipe sensor.

 Low pressure switch.

 High pressure switch.

 Crank case heater. (Low ambient 0°C or -15°C option for cooling only units).

 Pressure transducer, circuit 1. (Low ambient 0°C or -15°C option for cooling only units).

 Outdoor temperature sensor

1.- GENERAL CHARACTERISTICS

1.5.- UNIT DIMENSIONS

FIX 10-12

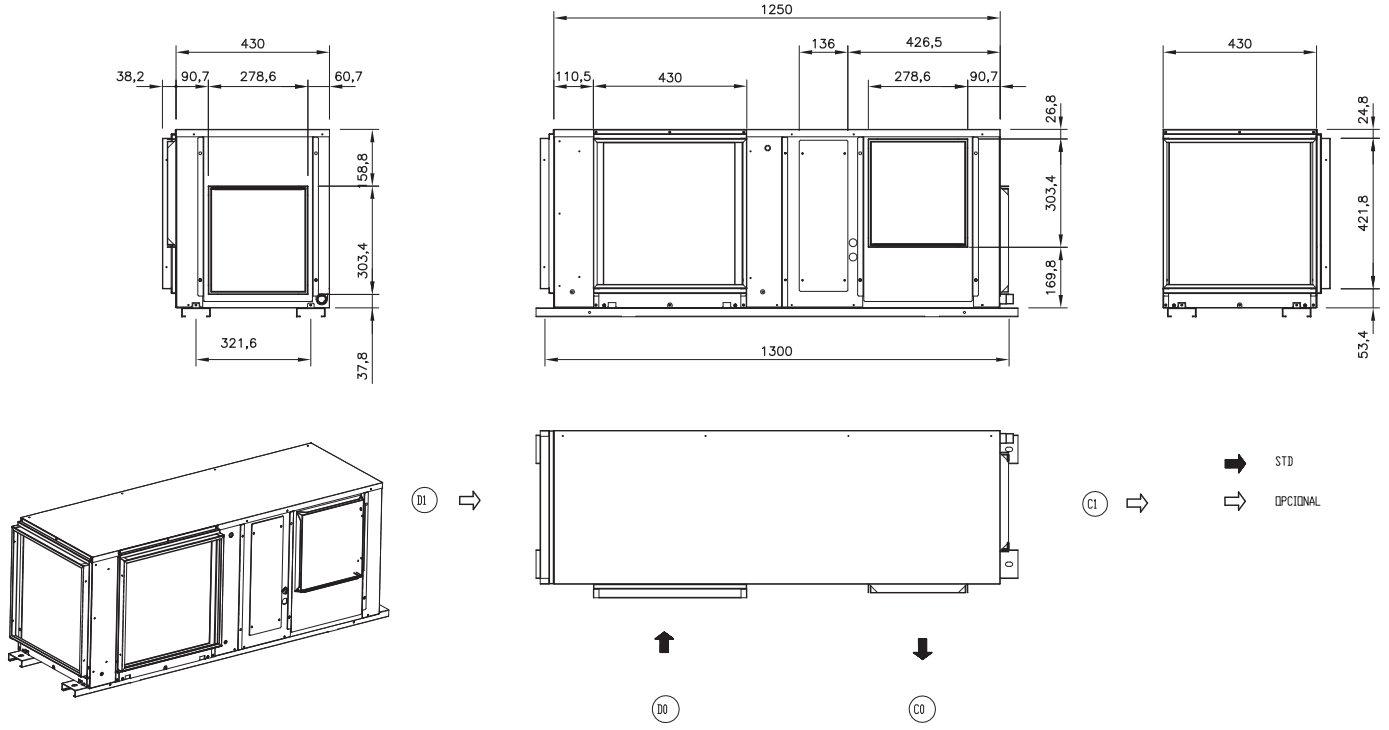

FSC / FSH 10-12

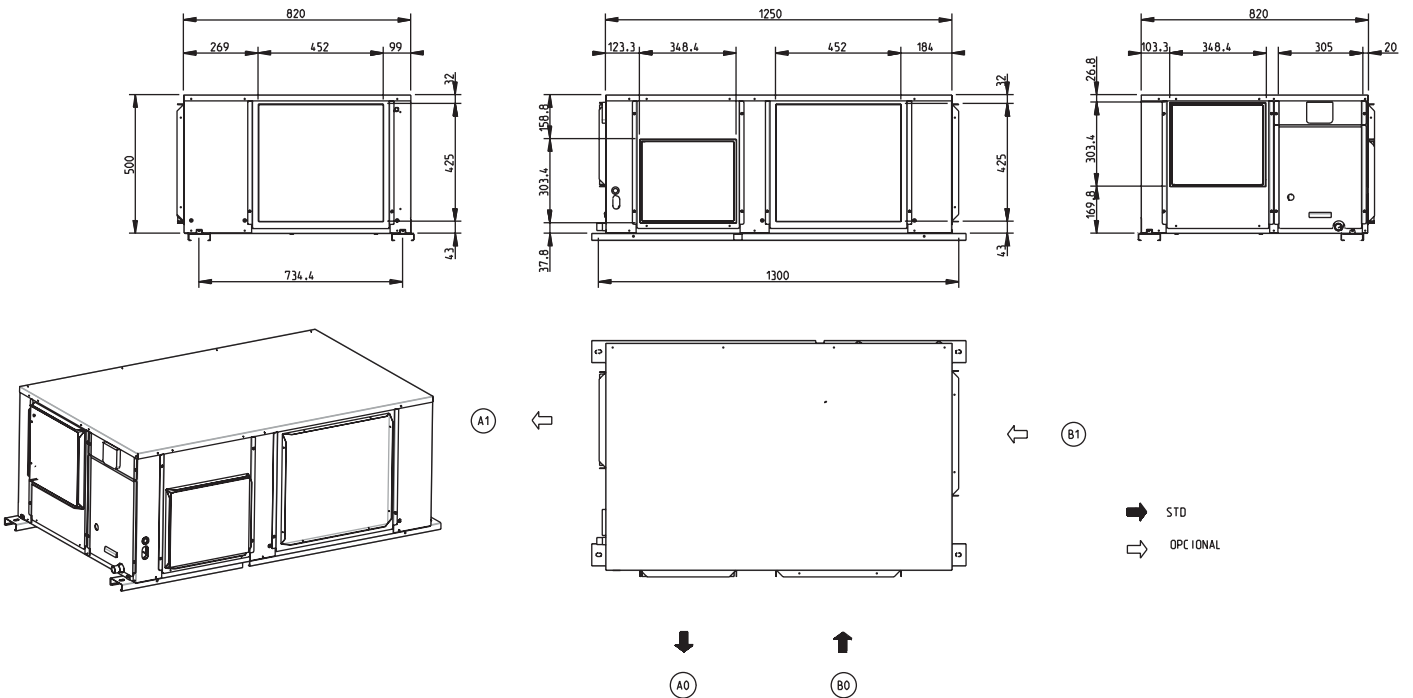

1.- GENERAL CHARACTERISTICS

1.5.- UNIT DIMENSIONS

FIX 15

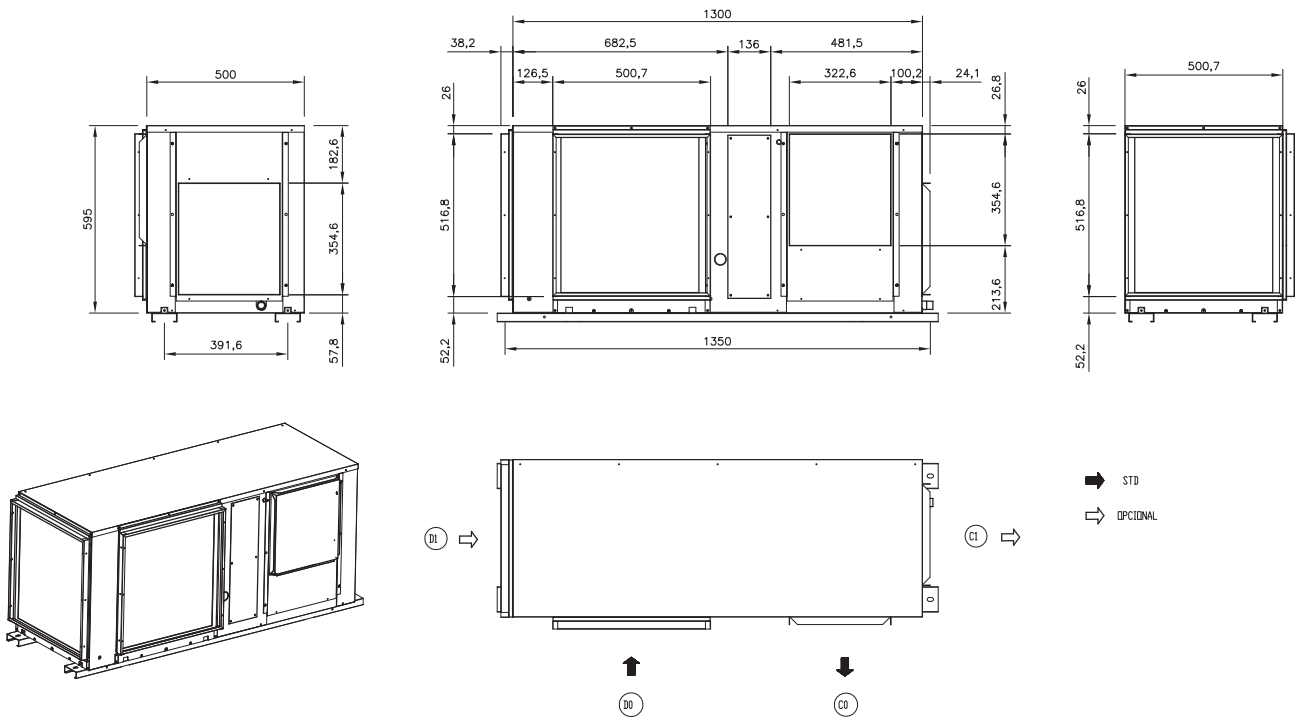

FSC / FSH 15

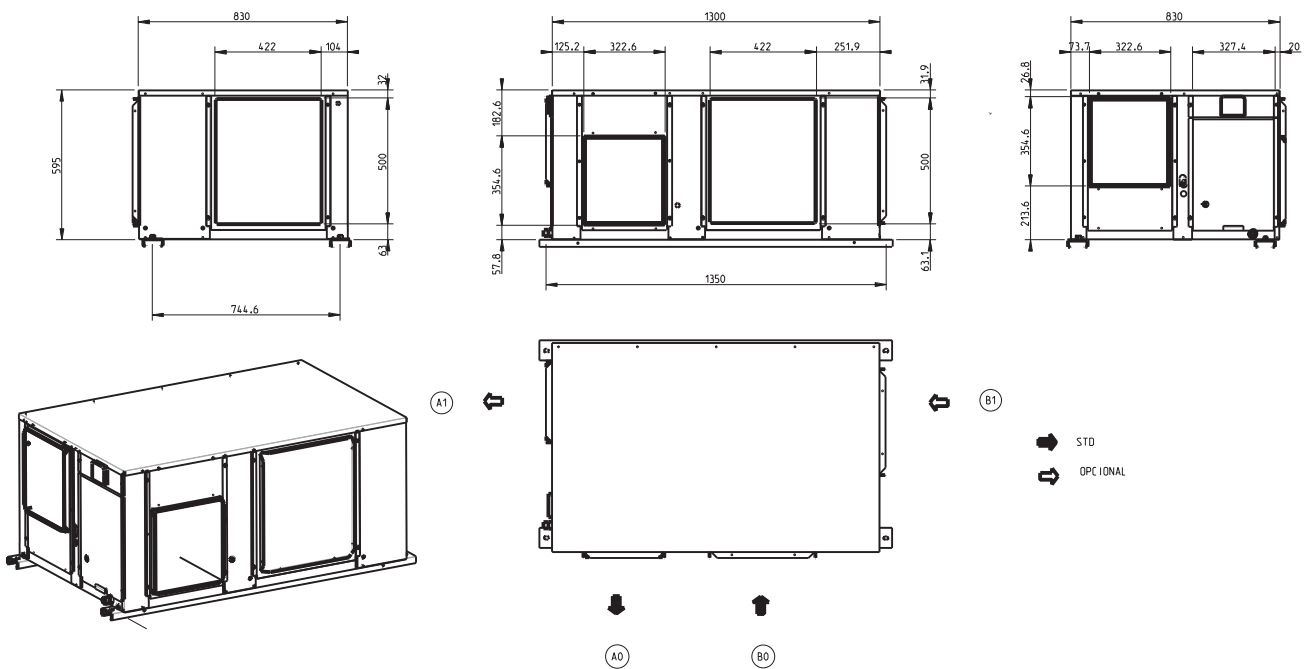

1.- GENERAL CHARACTERISTICS

1.5.- UNIT DIMENSIONS

FIC / FIH 20

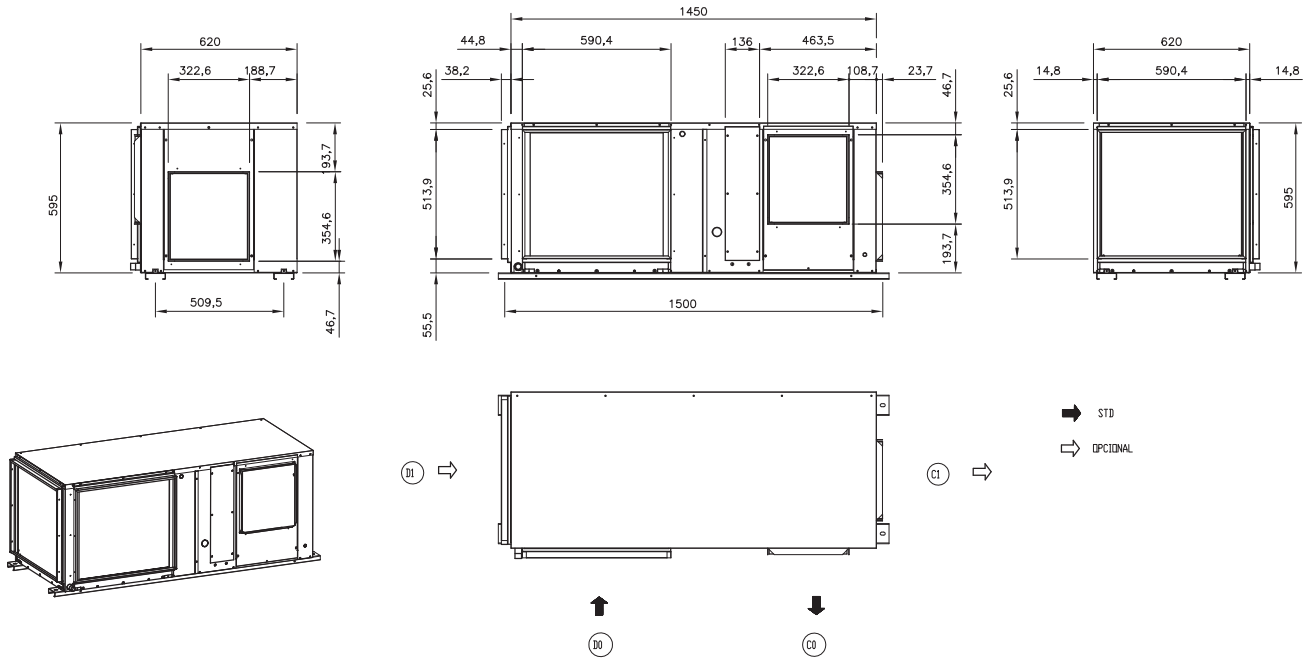

FSC / FSH 20

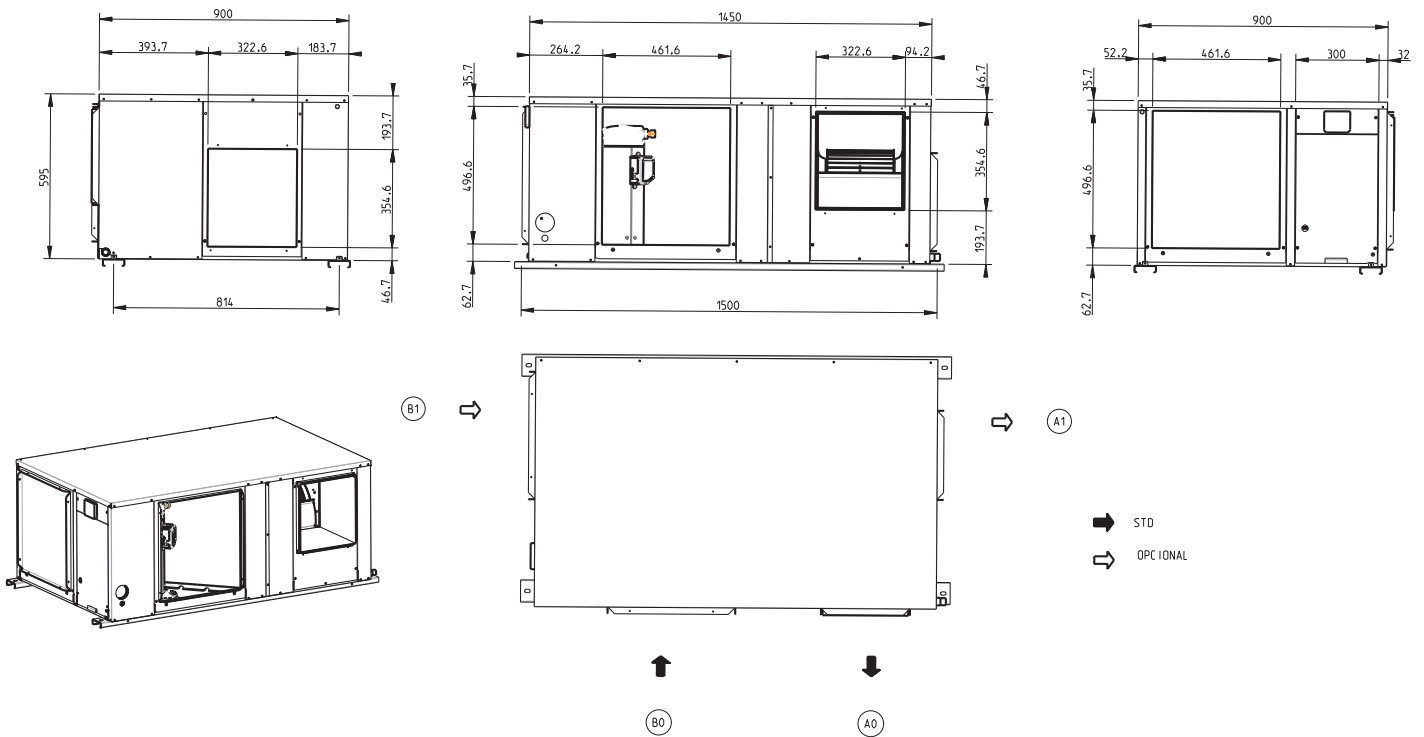

1.- GENERAL CHARACTERISTICS

1.5.- UNIT DIMENSIONS

FIC / FIH 25-30

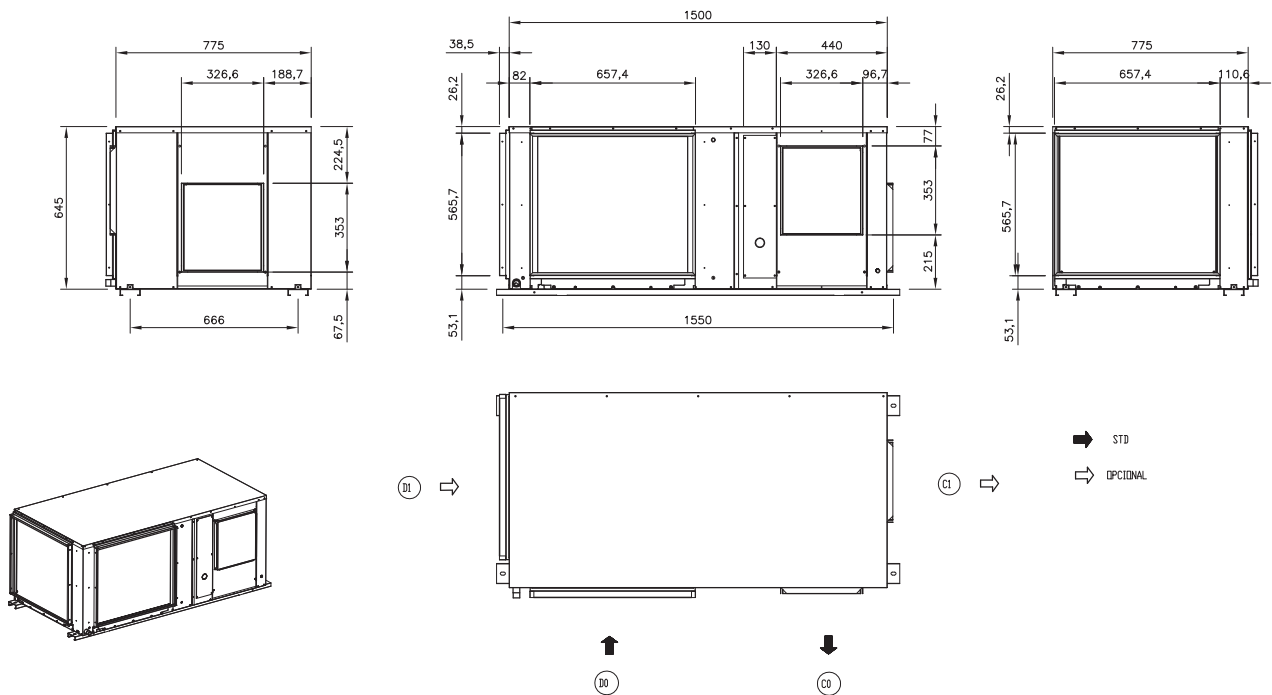

FSC / FSH 25-30

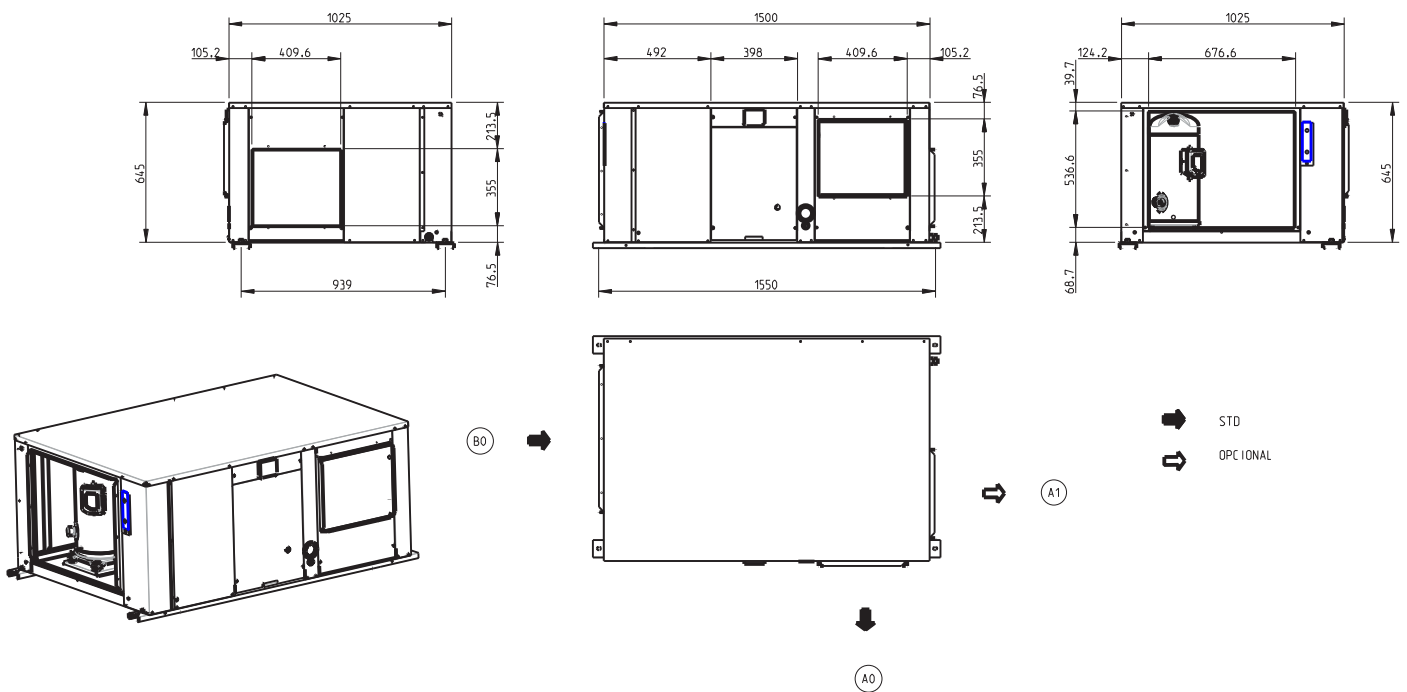

1.- GENERAL CHARACTERISTICS

1.5.- UNIT DIMENSIONS

FMC/FMH 10-12

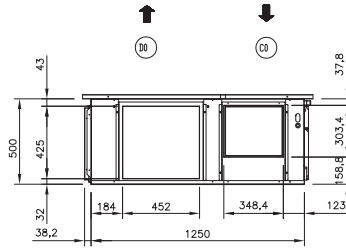
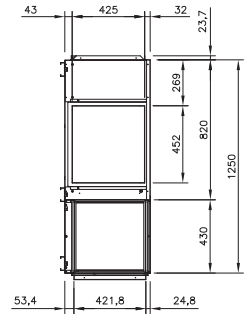
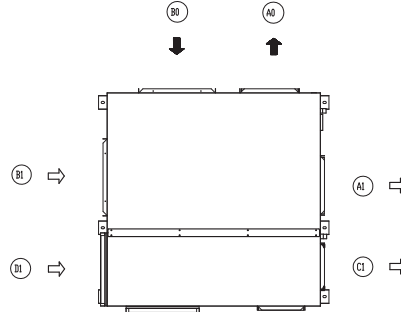
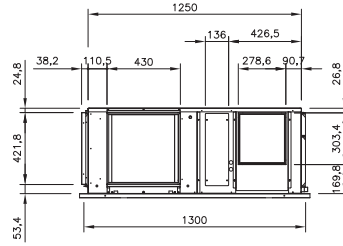
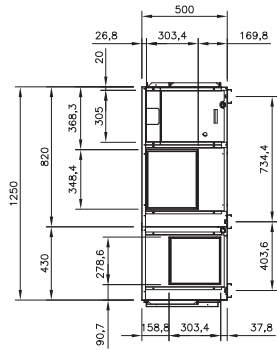
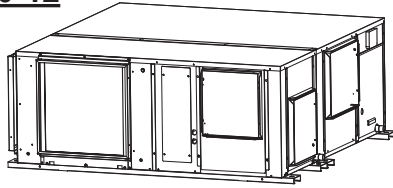

→ STD
⇌ OPCIONAL

FMC/FMH 15

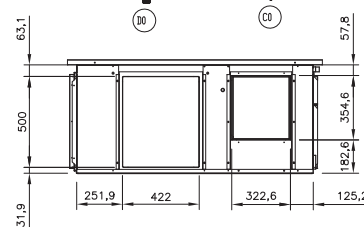
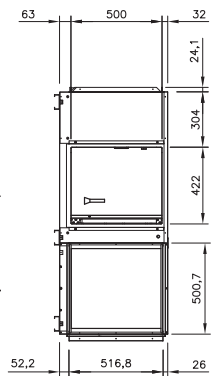
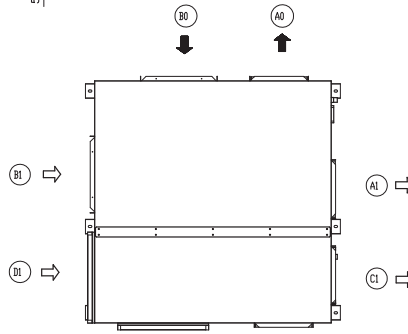
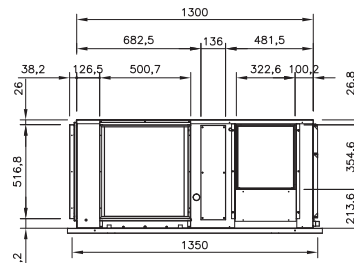
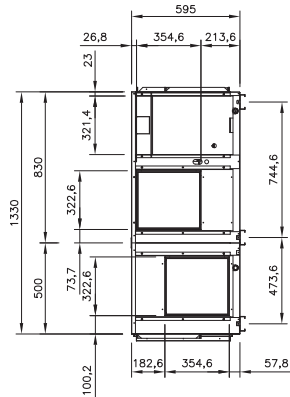
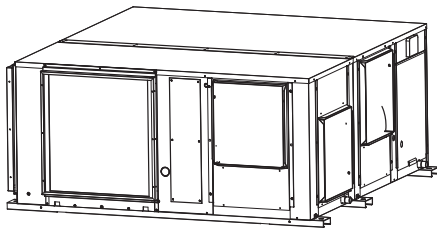

→ STD
⇌ OPCIONAL

1.- GENERAL CHARACTERISTICS

1.5.- UNIT DIMENSIONS

FMC/FMH 20

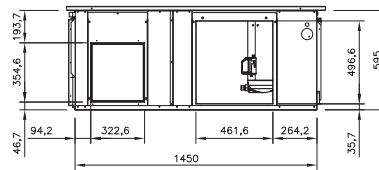
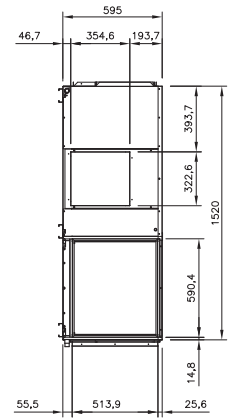
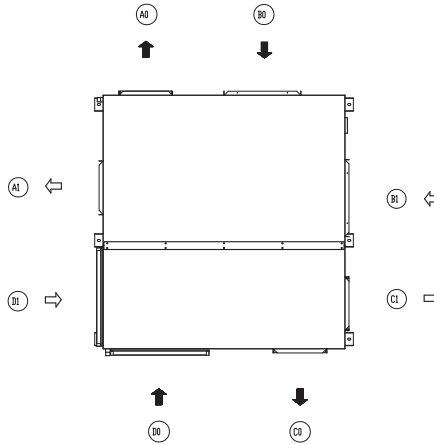
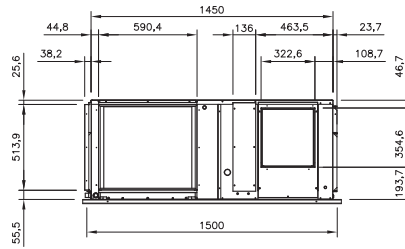
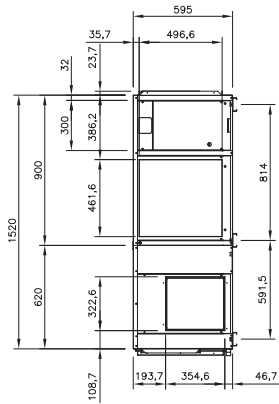
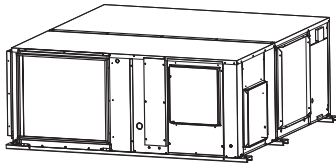

→ STD
⇌ OPTIONAL

FMC/FMH 25-30

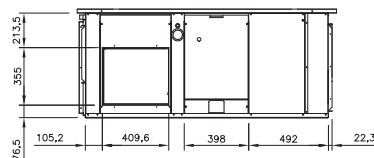
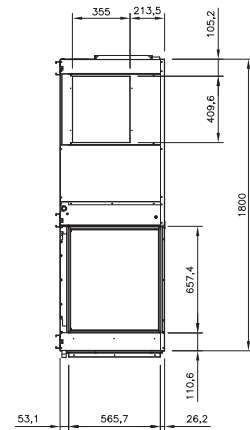
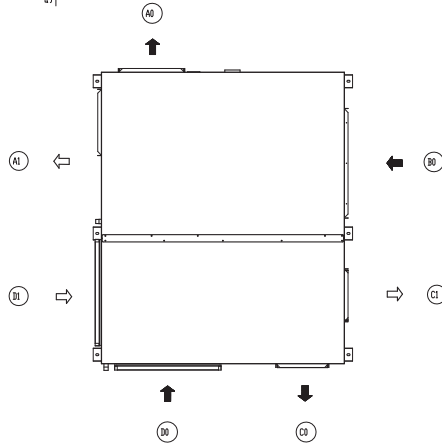
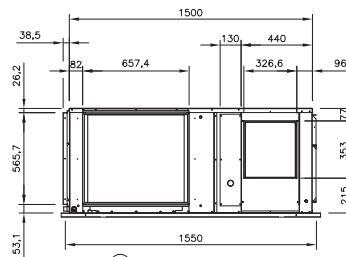
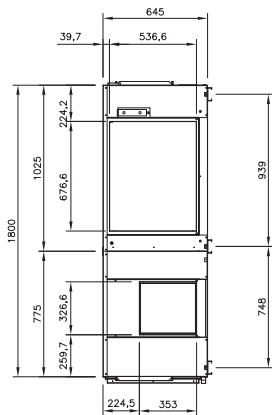
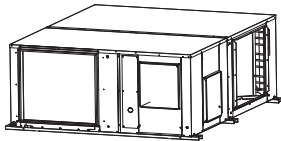

→ STD
⇌ OPTIONAL

1.- GENERAL CHARACTERISTICS

1.5.- DUCT POSITION

MODELS 10-12-15

PACKAGE UNIT

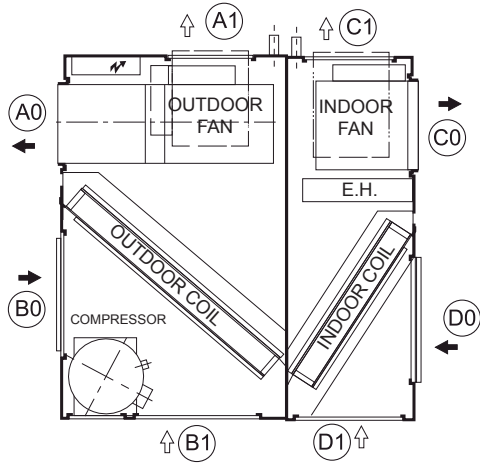

MODEL 20

SPLIT UNIT

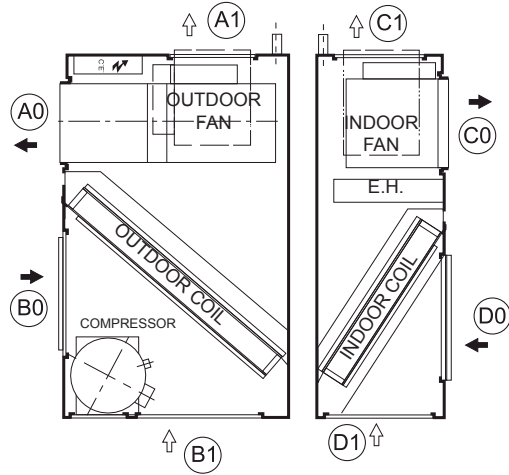

PACKAGE UNIT

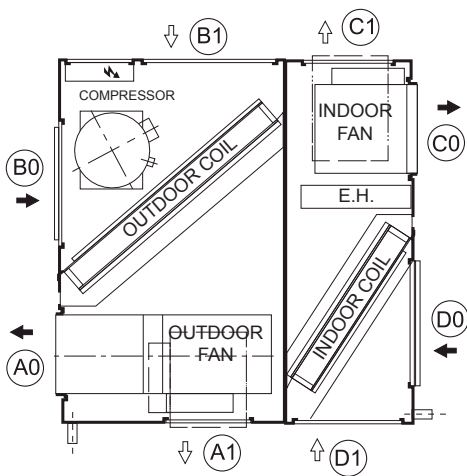

MODELS 25-30

SPLIT UNIT

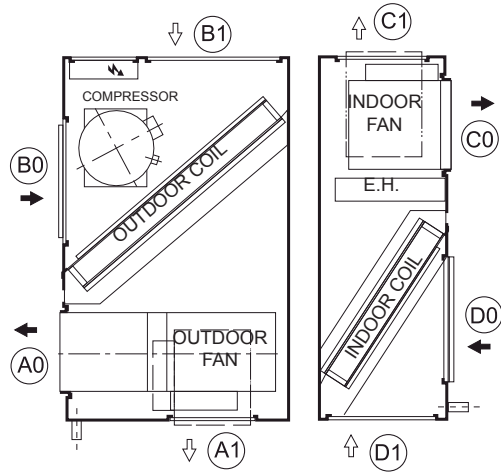

PACKAGE UNIT

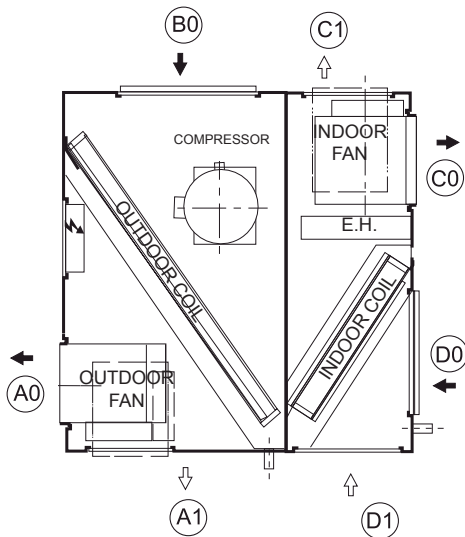

SPLIT UNIT

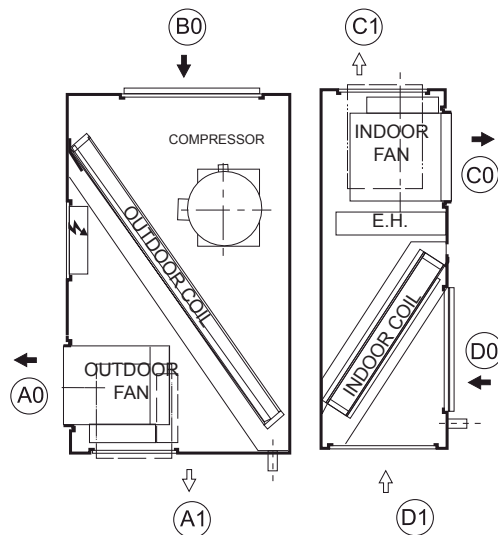

← STANDARD ←

OPTION ← ELECTRICAL BOX ←

2.- INSTALLATION

2.1.- PRELIMINARY PREPARATIONS



All INSTALLATION, SERVICE and MAINTENANCE work must be carried out by QUALIFIED PERSONNEL.

The unit must be transported in a HORIZONTAL POSITION on its metal mounting frame. Any other position may cause serious damage to the machine. When the unit is received, it should be checked to assure that it has received no shocks or other damage, following the instructions on the packaging. If there is damage, the unit may be rejected by notifying the LENNOX Distribution Department and stating why the machine is unacceptable on the transport agent's delivery note. Any later complaint or claim made to the LENNOX Distribution Department for this type of damage cannot be considered under the Guarantee.

Sufficient space must be allowed to facilitate installation of the unit.



When positioning the unit, be sure that the Rating Plate is always visible since this data will be necessary to ensure correct maintenance.

The units are designed to be installed with ducts designed by qualified technical staff. The joints to be used between ducts and openings in the unit should be Elastic Joints. Avoid the use of BYPASS joints between the extraction air and input air. The structure where the unit is placed must be able to support the weight of the unit during operation.



Defrosting:

To avoid ice accumulation in the drip tray, it may be necessary to install an electrical heater and inside the drainage connection, to drain correctly the water

The drainage must be always accessible through the indoor part, in order to remove easily the dirty than may be accumulated.

2.2.- UNIT ACCEPTANCE

All the units have metal bedplate profiles and wooden blocks for transportation.

These wooden blocks must be removed when positioning the unit in its final position.

PLACEMENT OF
BEDPLATE AND
TRANSPORTATION
BLOCKS

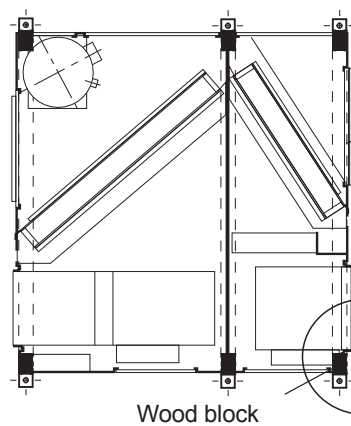

Para extraer los tacos de transporte, quite el tornillo y deslice el taco por el perfil metálico

Bedplate profile

Securing screw

Wood block

Wood block

Use separators

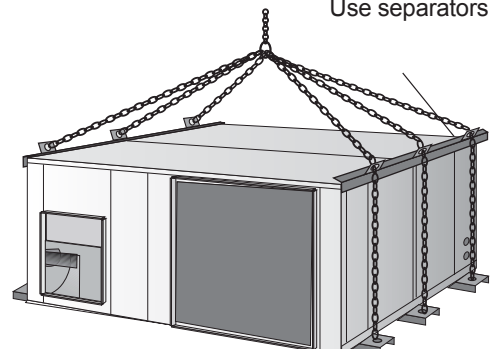

How to hoist the unit

If unloading and placement require the use of a crane, then secure the suspension cables as shown in the figure.

2.- INSTALLATION

2.3.- OPTIONAL OPERATIONS PRIOR TO UNIT INSTALATION

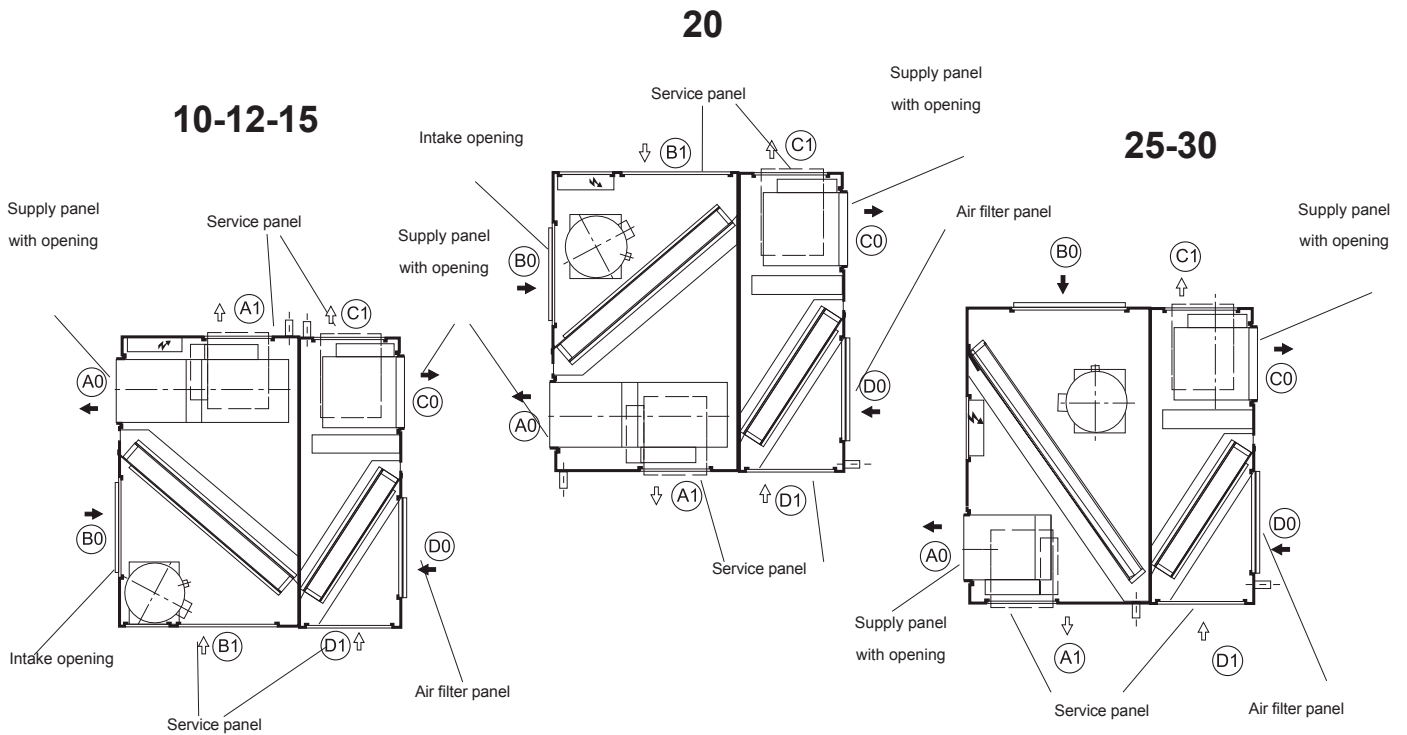

OUTDOOR SECTION

SUPPLY

From the position A0 to the position A1

- 1.-Remove the ceiling of the unit, the supply panel with opening and the service panel.
- 2.-Remove the motor-fan assembly from the unit unscrewing the supports from the base, and throwing away the extension collar, if there is one.
- 3.-Unscrew the supports that have been left on the fan-motor assembly.
- 4.-Turn the fan-motor assembly to its new position 90° horizontally and 180° on its shaft. The motor should now be accessible from the service panel in this new position.
- 5.-Screw down the fan-motor assembly in its new position using the supports.
- 6.-Assembly the supply panel with opening and the service panel in its new position, taking special care with the weather stripping.

INLET:

From the position B0 to the position B1

- 1.-Remove the intake opening and the service panel.
- 2.-Switch the position of the intake opening and service panels.

INDOOR SECTION

SUPPLY

From the position C0 to the position C1

- 1.-Remove the ceiling of the unit, the supply panel with opening and the service panel.
- 2.-Remove the motor-fan assembly from the unit unscrewing the supports from the base, and throwing away the extension collar, if there is one.
- 3.-Unscrew the supports that have been left on the fan-motor assembly.
- 4.-Turn the fan-motor assembly to its new position 90° horizontally and 180° on its shaft. The motor should now be accessible from the service panel in this new position.
- 5.-Screw down the fan-motor assembly in its new position using the supports.
- 6.-Assembly the supply panel with opening and the service panel in its new position, taking special care with the weather stripping.

INLET:

From the position D0 to the position D1

- 1.-Remove the intake air filter and the service panel.
- 2.-Switch the position of the air filter and service panels.

2.- INSTALLATION

2.4.- UNIT LOCATION

The bedplate is made up of three galvanized metal channels, capable of withstanding the weight of the units whether hung from the ceiling or mounted on the floor.

If the unit is floor mounted, then the profiles should be isolated with shock absorbing material such as anti-vibration or pads. Keep in mind that fans rotate at approximately 850 rpm.

If the unit is hung, M-10 threaded rods should be used along with shock absorbing ceiling supports.

UNIT HUNG WITH RODS

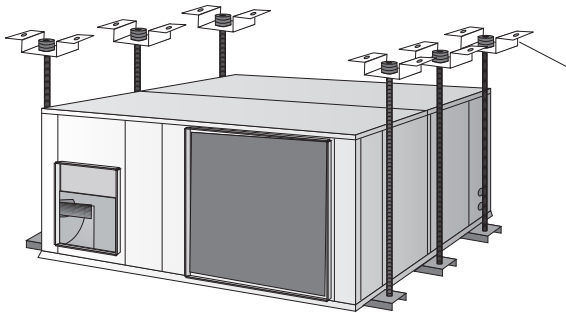

Ceiling supports
(shock absorbers)

Floor supports
(shock absorbers)

UNIT INSTALLED ON SHOCK ABSORBERS

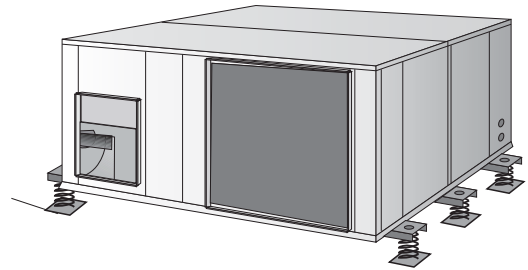

2.5.- INSTALLATION CLEARANCES

Clearance around the unit for service and maintenance

SERVICE SPACE

Space should be left free for access or servicing, to ease the installation of cables, drainage connections, electric installation and cleaning filters, as well as easy access to the unit.

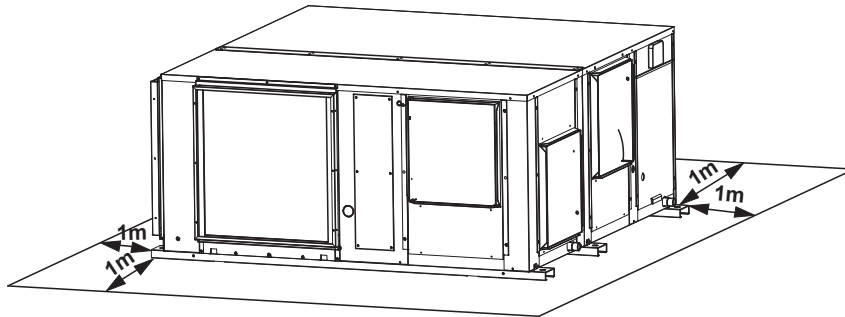

For the unit with option FREECOOLING, it should be kept in mind that bedplate anchors cannot be used to hang the unit.

2.6.- DRAINS

All the indoor and outdoor sections of these units have a 3/4" steel threaded drain pipe welded to the condensation tray.

Drainage pipes will be fitted for each tray through a siphon with a height difference of 80 mm. to avoid drainage problems from the depression formed by the fans. The pipes should have an inclination of 2% to ease drainage of condensation.

Also slightly tip the unit (2%) toward the drainage side. Check that the condensation trays are clean and free from dirt and other debris from the works and that water drains correctly.

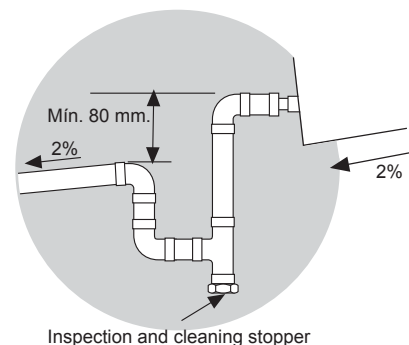

2.- INSTALLATION

2.7.- REFRIGERANT CONNECTIONS

Split units are supplied with gas and liquid lines sealed with copper covers, and located 60mm from casing.

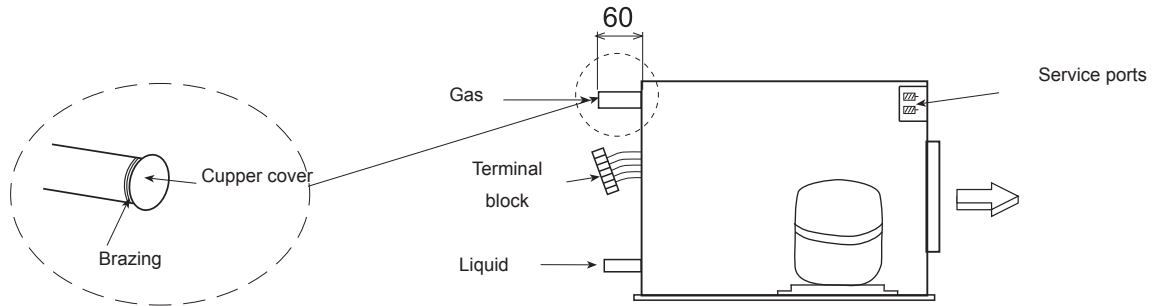

Split units are supplied with nitrogen gas, this must be removed and then proceed as follow:

1. Remove the nitrogen gas through the high and low 5/16" service ports located inside and provide a low vacuum for safety.
2. Remove the caps from the connecting lines.
3. Braze the piping connection lines. Select piping diameter from table 2.7.1.
(When brazing refrigerant pipes, nitrogen gas must be supplied into the pipes through the service ports to remove the air).
4. Leak test:
Add nitrogen gas, check that a pressure of 5 kg/cm² has been reached and that there are no leaks in the circuit or brazing by applying soapy water to the pipes which will cause the bubbles to form where there are leaks.
To detect small leaks, proceed as follows:
Add nitrogen gas and check that a pressure of 25 kg/cm² has been reached, there are no leaks if the pressure remains the same for at least 24 hours and the final pressure is not less than 10% below the initial pressure.
5. Ensure that the gas line is insulated.
6. Evacuation:
Remove the nitrogen gas, connect the gauge manifold and vacuum pump to both the liquid and gas lines, fully open the gauge manifold valve and switch on the vacuum pump. Check to make sure the gauge shows a pressure of -750mm Hg. Once a level of -750mm Hg is reached, keep the vacuum pump running for at least one hour.
7. Refrigerant charge:
 - Check TABLE 3.1. and 3.2. for the amount of refrigerant charge, depending on the length and size of the pipe connections.
 - Disconnect the vacuum pump and connect to the refrigerant-charging bottle. Open the charging pump and purge the air from the hose at the pressure gauge manifold.
 - Set up the amount of additional refrigerant on the weighing scale, open the high pressure and charged in the liquid state. If the total amount of refrigerant charge has not been reached because the pressure is balanced, turn off the high side of the gauge manifold, turn on the unit, and add the remaining amount of the refrigerant charge required slowly through the low side of the pressure gauge. (With R-410A refrigerant, the charging bottle must be in a vertical position and charged in the liquid state). Close the pressure gauge, disconnect it from the from the service port of the unit and fit caps on the service ports. The unit is then ready to operate.



**During installation operations, keep gas and liquid pipes covered, in order to prevent humidity and dirt, get into them.
Take special concern about refrigerant pipes are isolated.
Avoid collapse on line installation.**

2.- INSTALLATION

2.7.- REFRIGERANT CONNECTIONS

To locate the outdoor and the indoor units, refer to the following information:

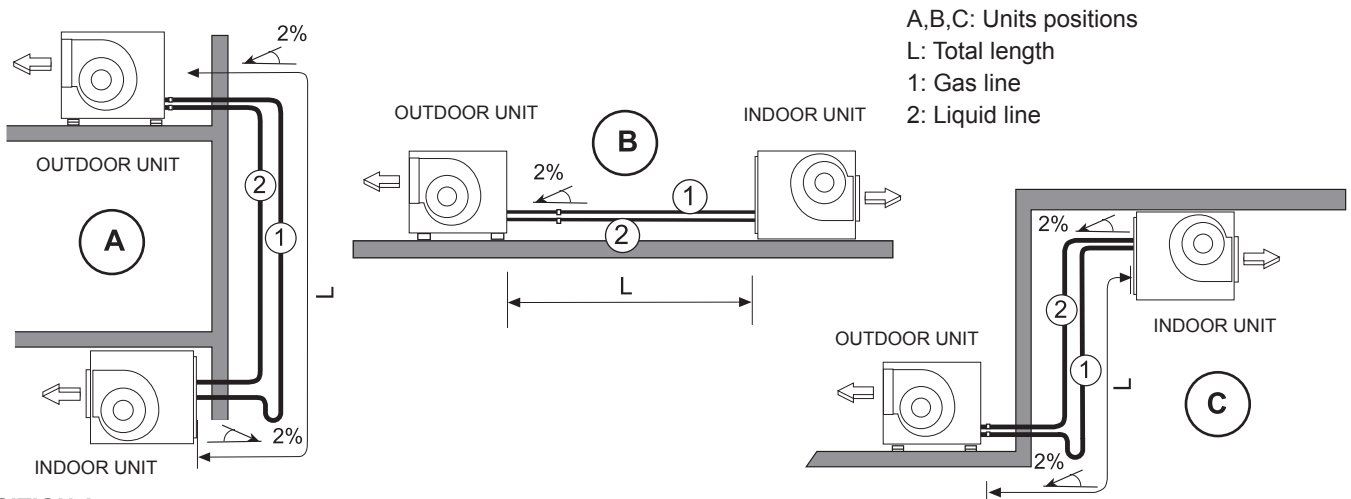

POSITION A:

A syphon suction must be installed on the vertical line of the gas line 1, and syphons must be installed every 8 meters upward. The minimum speed suction must not be below 6 m/s.

POSITION B:

Tip the lines toward the outdoor unit. Make special attention to the line length longer than 10m and avoid collapse on pipe lines installation.

DISPOSICIÓN C:

Install a syphon at the base of the vertical line, no more syphons are necessary.

TABLE 2.7.1.: REFRIGERANT LINES

REFRIGERANT LINES			UNIT-MODEL					
			10	12	15	20	25	30
Total length	0 to 30m	Liquid	3/8"	3/8"	1/2"	1/2"	5/8"	5/8"
		Gas	3/4"	3/4"	7/8"	7/8"	1 1/8"	1 1/8"
Maximum vertical line length (m)			15	15	15	15	15	15
Maximum number of bends			12	12	12	12	12	12



For other positions and lines lengths between 30 and 50m or longer, consult the commercial-technical department, pipe dimensions, syphon suction, isolations, refrigerant load, line lengths.

Split units are supplied with nitrogen gas. The installer should remove this gas and charge the units with the charge of refrigerant R410A, shown in the table 2.7.2 plus the charge by additional meter shown in the table 2.7.3.

TABLE 2.7.2.: REFRIGERANT CHARGE

MODELS		10	12	15	20	25	30
Refrigerant charge R-410A	Cooling only	2,14	2,57	3,55	4,46	5,38	6,15
	Heat pump	2,5	2,93	4	4,9	6,3	7

TABLE 2.7.3.: EXTRA REFRIGERANT CHARGE R410A BY METER

Liquid	Gas	g/m
3/8"	3/4"	57
1/2"	7/8"	108
5/8"	1 1/8"	177

2.- INSTALLATION

2.7.- ELECTRICAL CONNECTIONS



- BEFORE MAKING ANY ELECTRICAL CONNECTIONS, ENSURE THAT ALL CIRCUIT BREAKERS ARE OPEN.
- IN ORDER TO MAKE THE ELECTRICAL CONNECTIONS, FOLLOW THE ELECTRICAL DIAGRAM SUPPLIED WITH THE UNIT.

POWER SUPPLY

POWER SUPPLY 230V SINGLE PHASE UNITS  1N ~ 230V - 50 Hz + PE	UNIDAD MODELO	Nº DE CABLES X SECCIÓN (mm2)	
		Alimentación sin batería eléctrica	Alimentación con batería eléctrica
	10	3 x 4	3 x 16

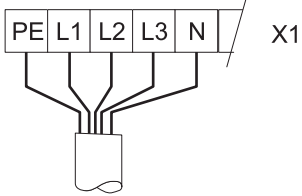
POWER SUPPLY 400V THREE-PHASE UNITS  3N ~ 400V - 50 Hz + PE	UNIDAD MODELO	Nº DE CABLES X SECCIÓN (mm2)	
		Alimentación sin batería eléctrica	Alimentación con batería eléctrica
	10	5 x 2,5	5 x 4
	12	5 x 2,5	5 x 4
	15	5 x 4	5 x 6
	20	5 x 4	5 x 10
	25	5 x 6	5 x 10
	30	5 x 6	5 x 10

VOLTAGE OPERATING LIMITS: 342-462V

MODELS	VOLTAGE	LIMIT
10	230V-1Ph-50 Hz	198-264 V
	400V-3Ph-50 Hz	342-462 V
12-15-20-25-30	400V-3Ph-50 Hz	

2.7.- ELECTRICAL CONNECTIONS

DC 40 THERMOSTAT, ELECTRICAL CONNECTION

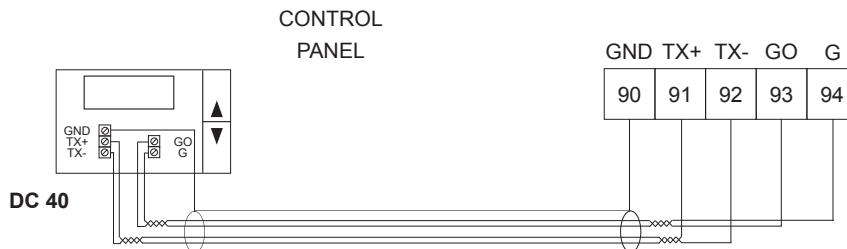

- 2 x Shielded twisted pairs AWG 20. 100 m maximum.
- 1x Shielded twisted pair AWG20 + 2 x 1,5 mm. 200m maximum.



IMPORTANT

THE SHIELDED CONNECTING CABLE BETWEEN THE CONTROL PANEL AND THE UNIT MUST BE SEPARATED FROM ANY OTHER TYPE OF ELECTRICAL WIRING. CONNECT IT TO THE ELECTRIC PANEL LOCATED IN THE OUTDOOR UNIT.

NOTES:

- For securing and connecting the Control Panel, consult the control panel Manual supplied with the unit.
- Connection between the DC40 and the unit must be made using shielded twisted pair cables (where the screens are connected to the control panel and the unit Electrical box).
- The Tx+ and Tx- polarity must strictly comply with the electrical diagram supplied with the unit.

3.- COMMISSIONING AND OPERATION

3.1.- PRELIMINARY CHECKS

1. Check that drain pipe connections and their fixtures are secure and that the level of the unit is tipped toward the drain.
2. Inspect the state of the ducts and grilles (clean and open grilles, no breaks in the duct, etc.)
3. Check that the power supply is the same as stated on the firm plate which is in agreement with the electrical diagram for the unit and that cable sizes are correct. Check that tightness of the electrical connections to their terminals and to ground.
4. Inspect the air filter, which should be in its housing and correctly positioned (the metal grille should be toward the inside)
5. Check with your hand that the fans turn freely.

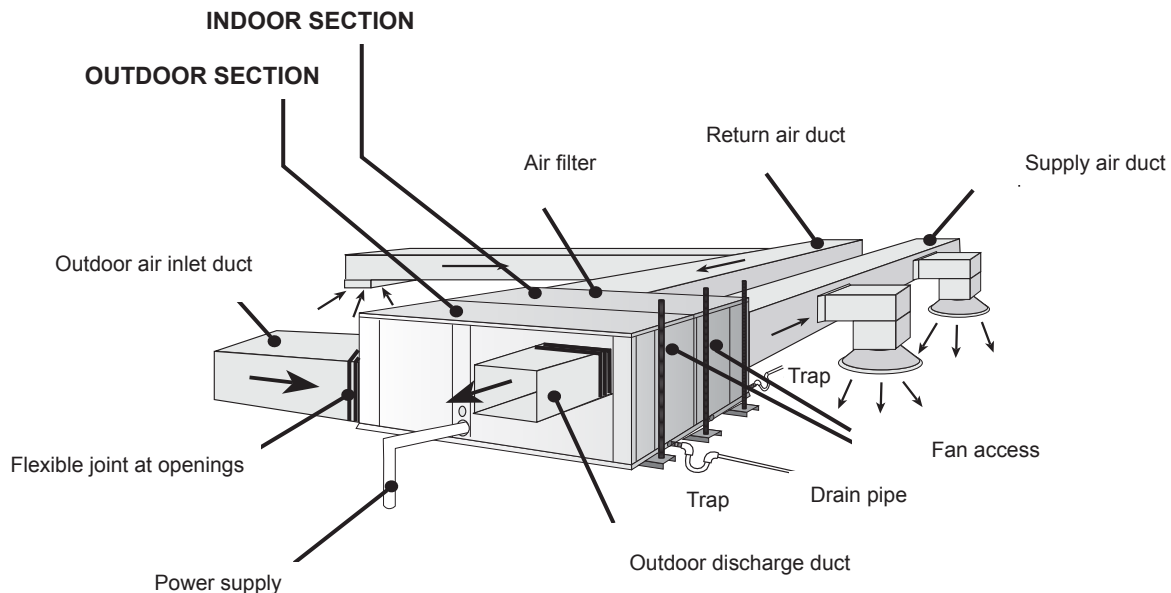

3.2.- PRELIMINARY CHECKS AT STARTUP

To start the unit, **follow the instructions given in the User Manual for the control** supplied with the unit (requiring operation in any of the modes, cooling, heating, or automatic).

After a time delay, the unit will start.

With the unit operating, check that the **fans are turning freely and in the correct direction.**

CHECK THAT THE COMPRESSOR IS ROTATING IN THE CORRECT DIRECTION.

- If you have the option phase rotation indicator, use it to check the correct rotation.
- If you do not have three phase return lock, check the correct direction of rotation. The suction pressure decreases and the discharge pressure increases when the compressor is started.
- If the connection is incorrect, rotation will be reversed, causing a high noise level and a reduction in the amount of current consumed. If this occurs, the compressor's internal protection system will operate to shut down the unit. The solution is to disconnect, reverse two of the phases and connect again.

WITH OPERATING UNIT, CHECK:

- Low pressure and high pressure.
- Use the evaporating and liquid temperature to calculate superheat and subcooling.
- Adjust the refrigerant charge and/or expansion valve according to the preceding values.

COMPRESSOR OIL LEVEL

The oil level must always be checked. When the compressor is at rest, the level should be between 1/4 and 3/4 in the sight glass, while when running the level should be between 3/4 and full.

In the event of having to add oil, remember the type of oil is synthetic POE.

The original oil charge in the compressor is ICI Emkarate RL32-3MAF. This type of oil must also be used when replacing the oil completely.

When only topping up, RL32-3MAF or Mobil EAC Artic 22C can be used.

3.- COMMISSIONING AND OPERATION

3.2.- PRELIMINARY CHECKS AT FIRST INSTALLATION



The unit must be installed in accordance with local safety codes and regulations and can only be used in a well ventilated area. Please read carefully the manufacturer's instructions before starting this unit

All work on the unit must be carried out by a qualified and authorised employee.

Non-compliance with the following instructions may result in injury or serious accidents.

Work on the unit:

The unit shall be isolated from the electrical supply by disconnection and locking using the main isolating switch. Workers shall wear the appropriate personal protective equipment (helmet, gloves, glasses, etc.).

Electrical system:

Electrical connections can become loose during transport. Please check them before starting-up the unit. Compressors with specific rotation direction. Check the correct rotation direction of the fan before closing the compressor circuit breakers. If the direction is incorrect, the phases must be reversed at the head of the main switch. Work on electric components shall be performed with the power off (see below) by employees having valid electrical qualification and authorisation.

Refrigerating circuit(s):

After more than 12 hours of power cut, the crankcase heater (compressor) should be powered for 5 hours before any return to service. Non-compliance with this instruction can cause deterioration of the compressors.

Monitoring of the pressures, draining and filling of the system under pressure shall be carried out using connections provided for this purpose and suitable equipment.

To prevent the risk of explosion due to spraying of coolant and oil, **the relevant circuit shall be drained and at zero pressure** before any disassembly or unbrazing of the refrigerating parts takes place.

There is a residual risk of pressure build-up by degassing the oil or by heating the exchangers after the circuit has been drained. **Zero pressure shall be maintained** by venting the drain connection to the atmosphere on the low pressure side.

The brazing shall be carried out by a qualified brazier. The brazing shall comply according to code ASME section IX following the procedures specific. In order to maintain CE marking compliance, replacement of components shall be carried out using spare parts, or using parts approved by Lennox.

Only the coolant shown on the manufacturer's nameplate shall be used, to the exclusion of all other products (mix of coolants, hydrocarbons, etc.).

CAUTION:

In the event of fire, refrigerating circuits can cause an explosion and spray coolant gas and oil.



4.- MAINTENANCE

4.1.- PREVENTIVE MAINTENANCE



**PREVENTIVE MAINTENANCE PREVENTS COSTLY REPAIRS.
THIS REQUIRES PERIODIC INSPECTIONS:**

- AIR FILTER :

The air filter can be removed through the side by sliding it over the rail or downwards.
(See figure).

For downwards removal, remove the two profiles that support it (depending on the model) which are under the filter guide rail and screwed onto the unit.

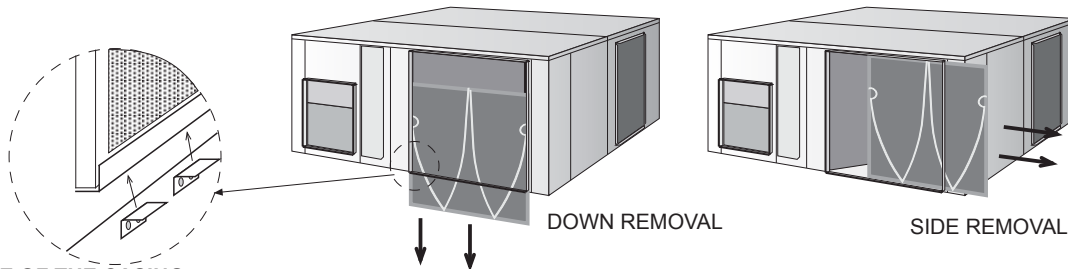

- GENERAL STATE OF THE CASING:

Furniture, paint, damage due to shocks, rust spots, levelling and supporting, condition of the shock absorbers, if installed, screwed panels, etc.

- ELECTRICAL CONNECTIONS:

State of hoses, tightness of screws, earthing, current consumption of the compressor and fans and check that the unit is receiving the correct voltage.

- COOLING CIRCUIT:

Check that the pressures are correct and that there are no leaks. Check that there is no damage to the pipe insulation, that the condition of the coils is good and that they are not blocked by bits of paper or plastic drawn in by the air flow, etc.

- COMPRESSOR:

If a sight glass is fitted, check the oil level.

Check the condition of the silentbloc mountings.

- FANS:

Check that fans turn freely and in the correct direction without excessive noise.

- CONTROL:

Check Set Points and normal operation.

4.2.- CORRECTIVE MAINTENANCE



**IMPORTANT
MAKE SURE THAT THE UNIT IS FULLY DISCONNECTED FROM THE POWER SUPPLY WHEN CARRYING OUT
ANY TYPE OF WORK ON THE MACHINE.**

If any **component** in the cooling circuit **is to be replaced**, follow these recommendations:

- Always **use original replacement parts**.
- If the component can be isolated, it is not necessary to remove the entire **refrigerant charge**, if the component cannot be isolated and the refrigerant charge is removed, it should be removed through the Schrader valves located in the outdoor section. Create a slight vacuum as a safety measure.
- Regulation **prohibits the release of refrigerant into the atmosphere**.
- If cuts must be made in the pipe work, use pipe cutters. **Do not use saws or any other tools that produce filings**.
- **All brazing must be carried out in a nitrogen atmosphere** to prevent corrosion forming.
- Use **silver alloy brazing rod**.
- **Take special care that the flame** from the torch is directed away from the component to be welded and cover with a wet rag to prevent overheating.

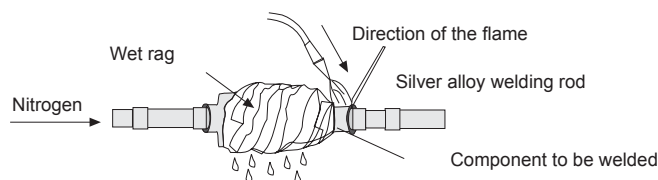

4.- MAINTENANCE

4.2.- CORRECTIVE MAINTENANCE

- **Take very special care if 4-way or check valves are to be replaced** since these have internal components that are very heat-sensitive such as plastic, teflon, etc.
- If a **compressor is to be replaced**, disconnect it electrically and un-braze the suction and discharge lines. Remove the securing screws and replace the old compressor with the new one. Check that the new compressor has the correct oil charge, screw it to the base and connect the lines and electrical connections.
- **Evacuate above and below through the Schrader valves** of the outdoor unit until -750 mm Hg is reached. Once this level of vacuum has been reached, keep the pump running for at least one hour.
DO NOT USE THE COMPRESSOR AS A VACUUM PUMP.
- **Charge the unit with refrigerant** according to the data on the Rating Plate for the unit and **check that there are no leaks.**



PRECAUTIONS TO BE TAKEN WHEN USING OF R-410A Refrigerant:

R-410A refrigerant is used in the unit; the following standard precautions for this gas should therefore be taken:

- The Vacuum Pump must have a Check Valve or Solenoid Valve fitted.
- Pressure Gauges and Hoses for exclusive use with R-410A Refrigerant should be used.
- Charging should be carried out in the Liquid Phase.
- Always use scales to weigh-in charge
- Use the Leak Detector exclusive for R-410A Refrigerant.
- Do not use mineral oil, only synthetic oil to ream, expand or make connections.
- Keep pipes wrapped before using them and be very thorough about any possible dirt (dust, filings, burrs, etc.).
- When there is a leak, collect what remains of the charge, create a vacuum in the unit and completely recharge with new R-410A Refrigerant.
- Brazing should always be carried out in a nitrogen atmosphere.
- Reamers should always be well sharpened.

4.- MAINTENANCE

4.3.- FAILURE DIAGNOSIS

In case of failure or malfunction of the unit, the display on the control panel will show an error or alarm warning which is explained in the control panel manual. Nevertheless, whenever there is a unit fault, the unit should be shut down and our service technicians consulted.

FAULT	POSSIBLE CAUSES	POSSIBLE SOLUTIONS
UNIT DOES NOT START	Fault in the power supply or insufficient voltage.	Connect the power supply or check the voltage.
	Circuit breakers have opened.	Reset.
	Power cable or control panel cable is defective.	Inspect and correct.
UNIT STOPS DUE TO HIGH PRESSURE DURING THE COOLING CYCLE	High pressure switch is defective.	Check cut-off pressure switch or replace pressure switch if necessary.
	Outdoor fan is not working.	Check for voltage, inspect the motor and turbine or replace if necessary..
	Outdoor fan turns in the wrong direction.	Reverse the power phases.
	Outdoor coil is dirty or clogged for passing air.	Inspect and clean.
	Excess refrigerant charge.	Remove the charge and charge according to the data on the rating plate.
UNIT STOPS DUE TO HIGH PRESSURE DURING THE HEATING CYCLE	The same causes and solutions as the cold cycle but with reference to the coils and indoor fan.	
UNIT STOPS DUE TO LOW PRESSURE	Low pressure switch defective.	Check the cut-off pressure with a pressure gauge and replace the pressure switch if necessary.
	Indoor fan is not working.	Check for voltage and inspect the motor, turbine and replace if necessary.
	Indoor fan turns in the wrong direction.	Reverse the power phases.
	Lack of refrigerant. Leak.	Correct leak, create vacuum and charge.
	Dirty air filter.	Inspect and clean
	Clogged cooling circuit. Dirty filter drier.	Inspect and correct or change the filter drier.
UNIT STARTS AND STOPS IN SHORT CYCLES	Compressor overcharged.	Inspect suction and discharge pressure values and correct.
	Compressor cuts off due to Klixon.	Check input voltage and voltage drop.
	Lack of refrigerant.	Correct leak and replace.
LOAD AND ABNORMAL NOISE IN THE COMPRESSOR (SCROLL)	Power supply phases inverted. (three-phase compressor).	Check and reverse power phases.

4.- MAINTENANCE

4.4.- REGULATION

	COOLING		HEATING	
	RESET	SET	SET	RESET
LP	3,5	4,5	1,7	2,7
HP	43	34	43	34
PT	outdoor fan speed regulation		defrost	

Tables values in bar g.

1.- OUTDOOR FAN SPEED REGULATION

(Low ambient 0°C or -15°C option)

CMC,CMH

LOW AMBIENT 0°C OPTION

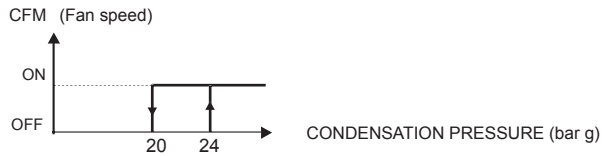

LOW AMBIENT -15°C OPTION

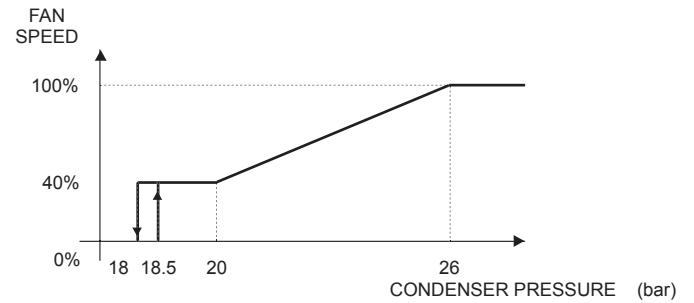

2.- DEFROST

- Start: suction pressure < pressure of starting defrost, for 60 sec.
- End: 30 bar or more than 8 minutes from the beginning of defrost.

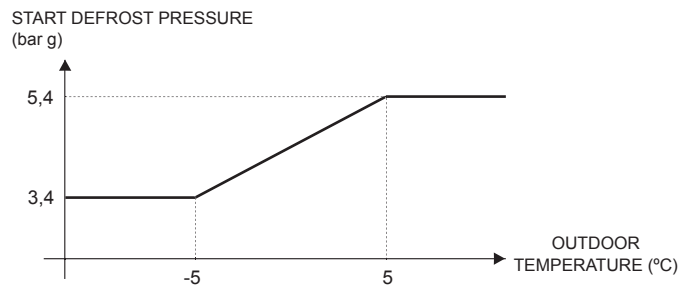

www.lennox europe.com

BELGIUM, LUXEMBOURG
www.lennoxbelgium.com

CZECH REPUBLIC
www.lennox.cz

FRANCE
www.lennoxfrance.com

GERMANY
www.lennoxdeutschland.com

GREAT BRITAIN
www.lennoxuk.com

NETHERLANDS
www.lennoxnederland.com

POLAND
www.lennoxpolska.com

PORTUGAL
www.lennoxportugal.com

RUSSIA
www.lennoxrussia.com

SLOVAKIA
www.lennoxdistribution.com

SPAIN
www.lennoxspain.com

UKRAINE
www.lennoxrussia.com

OTHER COUNTRIES
www.lennoxdistribution.com

Due to Lennox's ongoing commitment to quality, the Specifications, Ratings and Dimensions are subject to change without notice and without incurring liability.

Improper installation, adjustment, alteration, service or maintenance can cause property damage or personal injury.

Installation and service must be performed by a qualified installer and servicing agency.

