

NOBO

COMFORT YOU DESERVE

NOBO 'E' SERIES SLIMLINE RADIANT PANEL HEATERS
WITH LIFETIME PRODUCT WARRANTY

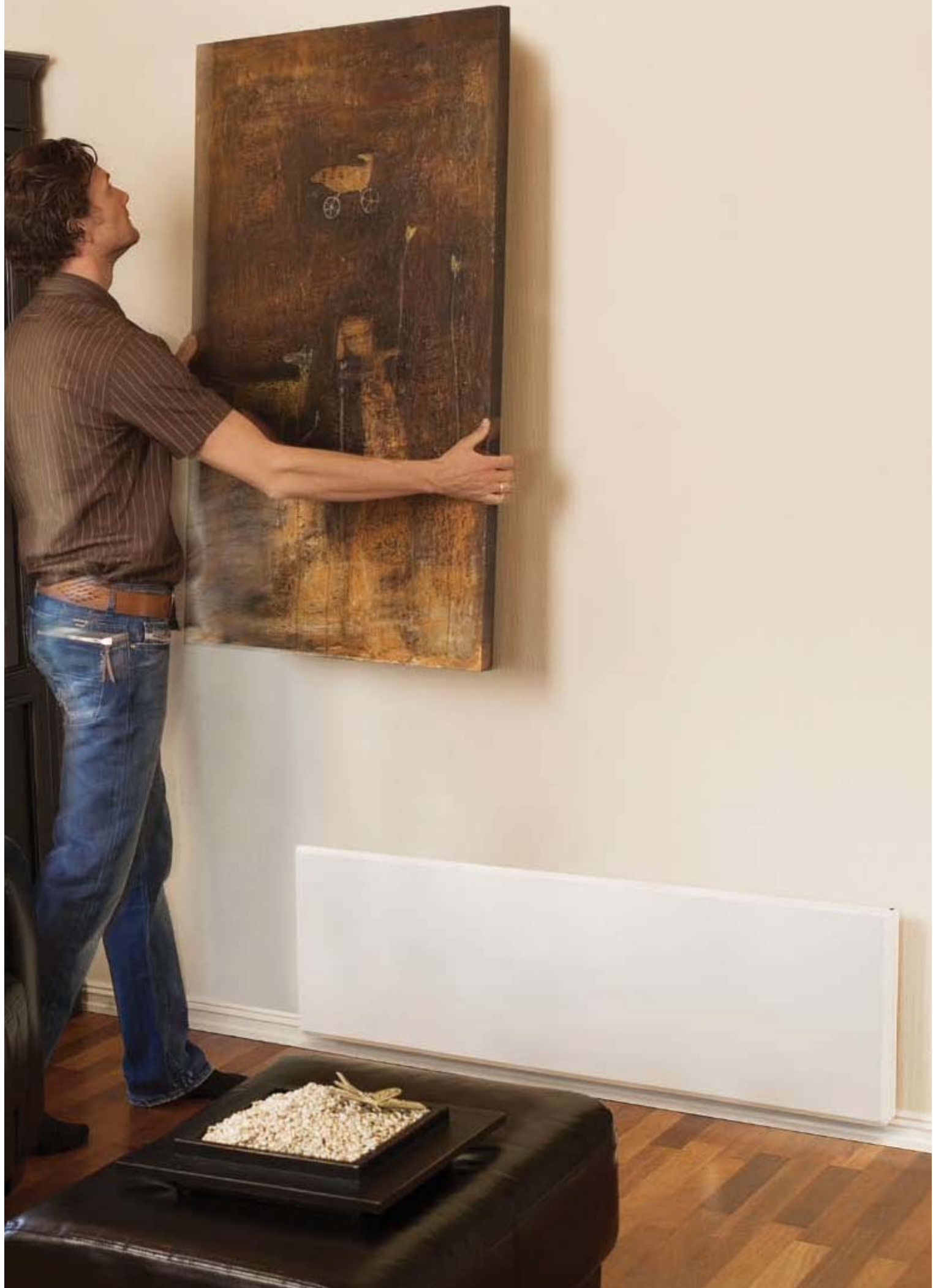



CHOOSE NOBO HEATING

The Norwegian company NOBO commenced making panel heaters in 1949 and is one of Europe's largest manufacturers of panel heaters. The company is well known for its innovative products, high quality and modern design. NOBO's clever design, incorporating a top mounted heat outlet, sets it apart from other panel heaters and enables them to be used in circumstances (for example behind furniture) where other panel heaters are not as effective or practical.

NOBO Slimline Radiant Panel Heaters have the following advantages over other brands of panel heaters:

- Attractive, modern clean face with no front grill
- Cheap to run – independent running costs documented and available
- Safer, low surface temperature on the front panel
- Power point and cable out of sight behind the heater
- Slimline – only 50mm thick
- Large panel surface area equals greater radiant heat, and more comfort
- Can be located close to or behind furniture

DUAL HEAT

NOBO Radiant Slimline Panel Heaters warm your room with a combination of both radiant and convection heat.

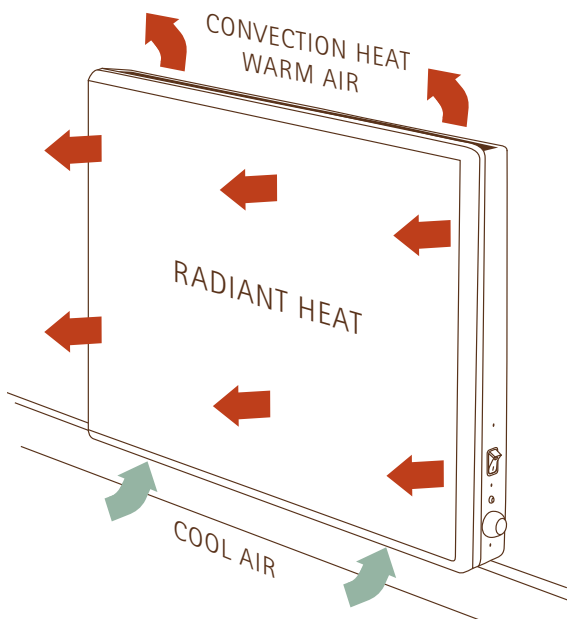

Just like the sun, radiant heat is multi-directional, and works on the principle of warming surfaces and objects within a room. Radiant heat is universally regarded as a very efficient, healthy and comfortable method of heating.

- **Efficiency:** In a typical room, there are more objects down low at people level. When these objects are heated, they have the ability to maintain the heat in the room for longer periods of time.
- **Health:** Radiant heat does not create air movement, therefore dust and air borne particles are not distributed around the room.
- **Comfort:** The absence of air movement helps to maintain your own body temperature.

Convection heat is gently distributed throughout the room through the top of the panel heater. NOBO's unique design draws in cold air across the entire width of the panel, heating it as it passes over the element, producing natural convection (without a fan).

With NOBO both types of heat happen simultaneously – resulting in the dual process of heating the room from the floor up (with radiant heat), and from the ceiling down (with convection heat), ensuring a quick start up, effective performance, and economical operation.

ENERGY EFFICIENCY

NOBO Slimline Radiant Panel Heaters are rated as 100% efficient because all energy used is converted to heating your room. There are no fans, or mechanical moving parts to waste energy or break down.

Accurate electronic thermostats also ensure efficiency. Further economies and convenience can be achieved by installing timer models for automatic on/off operation. Due to their rapid start up, it is recommended to operate your NOBO panel heaters only for the hours heating is required. Or with the convenience of the timer models, preheat your room by programming it to switch on 15 - 30 minutes before use.

ROOM ZONING

The most efficient, economical and comfortable way to heat your home is on a room by room basis. NOBO Slimline Radiant Panel Heaters can provide independent zoning for every room or living area.

NOBO Slimline Radiant Panel Heaters are often used in conjunction with other heating systems. This typically applies when a large or open living area has its own heat source, for example a reverse cycle heating and air conditioning system or gas fireplace, complemented with NOBO panels in the bathrooms and smaller rooms such as studies. This results in an integrated, flexible and fully zoned system.

'E' SERIES PRODUCT RANGE



E4E07 - without timer E4EU07 - with timer

Dimensions (W×H×D) 625mm × 400mm × 50mm

Approx. area heated* 7.5m² - Small En Suite

Watts 750

Running Cost* 5 cents / hour as tested



E4E10 - without timer E4EU10 - with timer

Dimensions (W×H×D) 775mm × 400mm × 50mm

Approx. area heated* 10m² - Bathroom / Bedroom 3 or 4

Watts 1000

Running Cost* 6 cents / hour as tested



E4E12 - without timer E4EU12 - with timer

Dimensions (W×H×D) 975mm × 400mm × 50mm

Approx. area heated* 12m² - Study / Bedroom 2
/ Smaller Bedroom 1

Watts 1250

Running Cost* 8 cents / hour as tested



E4E15 - without timer E4EU15 - with timer

Dimensions (W×H×D) 1125mm × 400mm × 50mm

Approx. area heated* 15m² - Average Bedroom 1

Watts 1500

Running Cost* 9 cents / hour as tested

LIFETIME PRODUCT WARRANTY: NOBO E Series panel heaters are warranted for their lifetime.



E4E20C Compact - without timer
E4EU20C Compact - with timer

Dimensions (W×H×D)	1125mm × 400mm × 50mm
Approx. area heated*	20m ² - Living Area / Larger Bedroom
Watts	2000
Running Cost*	13 cents / hour as tested



E4E24 - without timer E4EU24 - with timer

Dimensions (W×H×D)	1525mm × 400mm × 50mm
Approx. area heated*	24m ² - Larger Living Area
Watts	2400
Running Cost*	15 cents / hour as tested

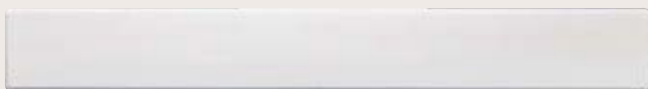

E2E12 Skirting Model - without timer

Dimensions (W×H×D)	1525mm × 200mm × 50mm
Approx. area heated*	12m ² - Study / Bedroom 2 / Smaller Bedroom
Watts	1200
Running Cost*	8 cents / hour as tested

* Running cost calculated using a tariff rate of 12.5 cents per kilowatt hour.

See the next two pages for information on panel heater selection, installation (permanent and portable) and running costs.

SIZING CHART AND PANEL HEATER SELECTION

For effective and efficient performance of your heating system, it is essential to size the heating system's output to the area, or room size being heated. Factors which impact the heating effectiveness, such as insulation, building construction etc. must also be allowed for by applying the "Correction Factors" below.

Step 1 – Determine the correct wattage needed for a room built to current construction standards

- Ceiling insulation rated at minimum R2.5
- Ceiling height up to 3.0 metres
- Window coverings with insulating properties
- External wall insulation rated at minimum R1.5
- Window area up to 35% of external wall area

Measure the width (W) and length (L) of the room in metres and use the Sizing Chart below to determine the wattage needed to heat the room. Rooms with an irregular shape, or with an adjoining open space such as an entry/hallway, can be sized by "squaring" them off to make several rectangles, and totalling the wattage required. Wattage required is typically 100 watts per square metre of floor area of the room.

W × L	2.0 M	2.5 M	3.0 M	3.5 M	4.0 M	4.5 M	5.0 M	5.5 M	6.0 M	6.5 M	7.0 M	7.5 M	8.0 M
1.0 M	200	250	300	350	400	450	500	550	600	650	700	750	800
1.5 M	300	375	450	525	600	675	750	825	900	975	1050	1125	1200
2.0 M	400	500	600	700	800	900	1000	1100	1200	1300	1400	1500	1600
2.5 M	500	625	750	875	1000	1125	1250	1375	1500	1625	1750	1875	2000
3.0 M	600	750	900	1050	1200	1350	1500	1650	1800	1950	2100	2250	2400
3.5 M	700	875	1050	1225	1400	1575	1750	1925	2100	2275	2450	2625	2800
4.0 M	800	1000	1200	1400	1600	1800	2000	2200	2400	2600	2800	3000	3200
4.5 M	900	1125	1350	1575	1800	2025	2250	2475	2700	2925	3150	3375	3600
5.0 M	1000	1250	1500	1750	2000	2250	2500	2750	3000	3250	3500	3750	4000

Step 2 – Apply Correction Factors if applicable

Add 40% to wattage for one or more of these factors	Add 20% to wattage for one or more of these factors	Deduct 20% from wattage for one or more of these factors
<ul style="list-style-type: none"> - Bathrooms or en suites - Solid brick - Living area with void or stairway to upper level 	<ul style="list-style-type: none"> - Ceiling height above 3.0 metres - Window area more than 35% of external wall area - No ceiling insulation or insulation rated less than R2.5 - No wall insulation 	<ul style="list-style-type: none"> - Ceiling insulation rated at R3 and above - Double glazed windows

Note: In some instances, several "Correction Factors" are required.

Eg: A solid brick room with 3.3m ceilings, requires a "Correction Factor" of an Extra 60%.

Step 3 – Panel Heater Selection

Once the required wattage has been determined, simply refer to the available NOBO models in the chart below and select the most suitable size heater or combination of heaters to suit your determined wattage. Note that it is always safer to "upsized" the wattage output. If the required wattage exceeds 2400 watts (the largest panel size), more than one NOBO must be installed. A combination of any size NOBO panel heaters can be selected, providing the total installed wattage matches or exceeds the determined wattage.

Model (without timer / with timer)	Watts	Amps	Dimensions (LxHxW mm)	Approx. Area Heated (m ²)	Approx. Running Cost* (cents per hour)				Suggested Placement
					Tariff c/kWH				
					12.5	17	20	24	
E4E07 / E4EU07	750	3.12	625x400x50	7.5	5	6	8	9	Small En Suite
E4E10 / E4EU10	1000	4.16	775x400x50	10	6	9	10	12	Bathroom / Bedroom 3 or 4
E4E12 / E4EU12	1250	5.20	975x400x50	12	8	11	13	15	Study / Bedroom 2 / Smaller Bedroom 1
E4E15 / E4EU15	1500	6.25	1125x400x50	15	9	13	15	18	Average Bedroom 1
E4E20C / E4EU20C	2000	8.33	1125x400x50	20	13	17	20	24	Larger Bedroom / Living Area
E4E24 / E4EU24	2400	10.00	1525x400x50	24	15	20	24	29	Larger Living Area
E2E12	1250	5.20	1525x200x50	12	8	11	13	15	Study / Bedroom 2 / Smaller Bedroom 1

* See opposite page for more information on running costs.

PERMANENT AND PORTABLE INSTALLATION

Each NOBO panel heater comes complete with a wall mounting bracket, and is easily installed on a plaster, timber or masonry wall by following the instructions provided. Four fixing points are required. Wall mates or toggles straight into plaster is sufficient – locating a stud is not essential. For a clean appearance, NOBO panel heaters can be installed in front of a standard power outlet.

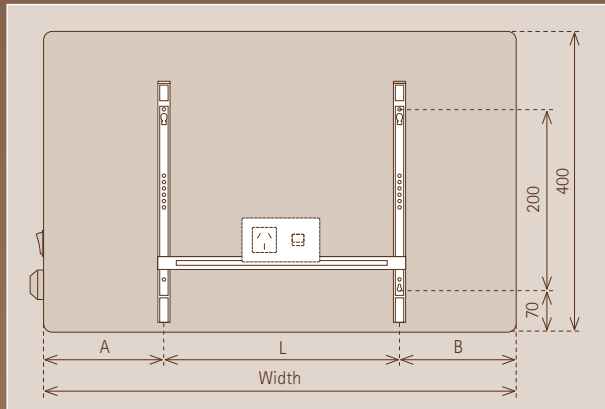

E SERIES DIMENSIONS					
Model (without timer / with timer)	Watts	Width (mm)	A (mm)	L (mm)	B (mm)
E4E07 / E4EU07	750	625	162.5	300	162.5
E4E10 / E4EU10	1000	775	187.5	400	187.5
E4E12 / E4EU12	1250	975	187.5	600	187.5
E4E15 / E4EU15	1500	1125	262.5	600	262.5
E4E20C / E4EU20C	2000	1125	262.5	600	262.5
E4E24 / E4EU24	2400	1525	262.5	1000	262.5

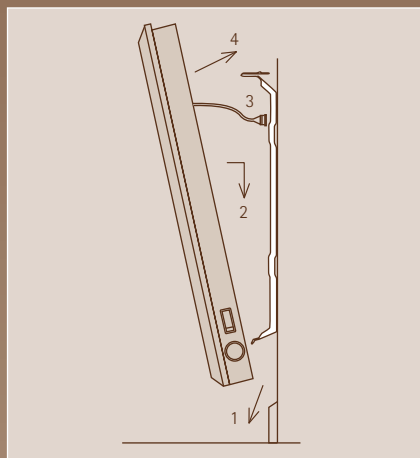

The bracket design allows the panel heater to be unclipped and tilted forward for cleaning and access to the power point.

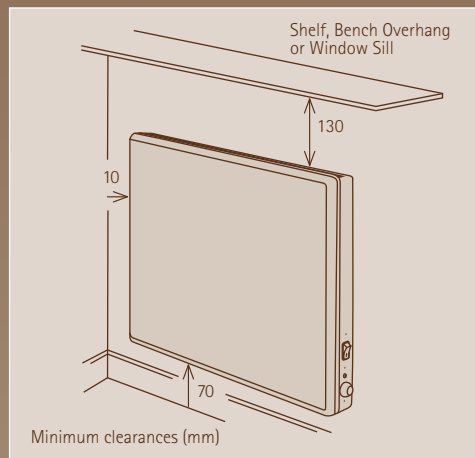

The recommended height off the floor is a minimum of 70mm. The sides of the panel heater can be installed within 10mm of a corner or furniture located against a wall. Directly under windows is an ideal location.

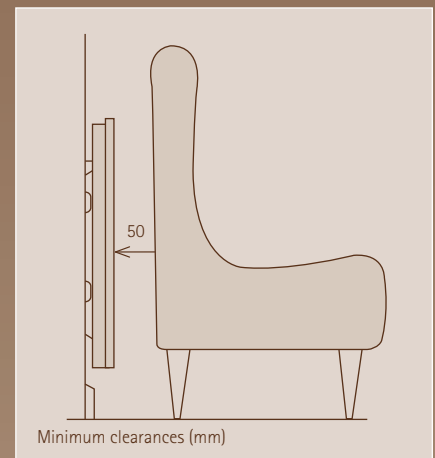

They can also be installed behind low furniture with a minimum 50mm clearance.

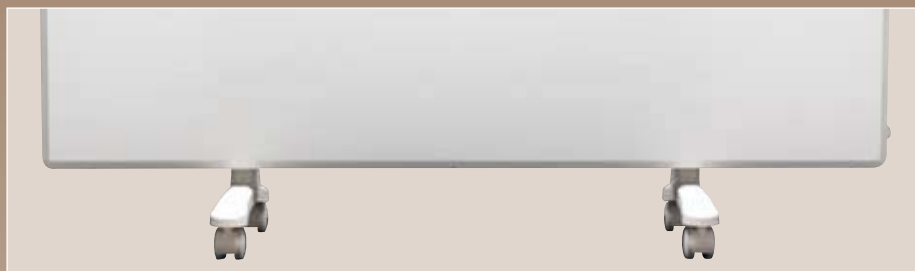

Legs - with castors. Available as an option for portable use. The heater can be easily moved from room to room.

***RUNNING COSTS:** NOBO panel heaters are available in various wattages (sizes) which correspond to the power used when the heater is operating. To achieve economical running costs they must be sized correctly for the room to be heated, and the thermostat set at 18-20 degrees Celsius. On initial start-up when the room is cold, the panel heater will heat continuously until the desired comfort temperature is reached. To maintain this temperature the electronic thermostat will switch the heater on and off and only draw power for 50% of the time, called "Cycling at 50%".

Electricity is charged in cents per kW per hour. To calculate the hourly running cost after initial warm up, check your latest power bill for the tariff in cents per kW per hour, determine the size of your panel heater in kW (1,000 watts = 1 kW or kilowatt) and substitute this value in the formula:

Cents per hour running cost after warm up = Cycle rate (50%) x tariff (cents per kW hour) x kW (size of heater).

See the table on the left for approximate hourly running costs for a range of tariffs. Your tariff rate and hourly running costs may be different to the ones stated.

Undersizing (using a lower wattage than recommended by NOBO to heat the area concerned) will result in cycling at a lesser %. In the worst case this could result in a doubling of hourly running costs.



ALSO AVAILABLE FROM NOBO...

THE POLO RANGE OF SPECIALISED HEATING
AND COOLING PRODUCTS

POLO

COMFORT YOU DESERVE

POLOCOOL

COMFORT YOU DESERVE



POLO Radiant Ceiling Panel Heaters

- Perfect for difficult to heat areas – large open plan areas (inside and out), high ceilings
- Can be wall mounted
- Available in sizes from 900 Watts to 4500 Watts



POLO Stainless Steel Heated Towel Ladders

- High quality polished stainless steel
- Concealed wiring
- Available in 2 sizes for small or large bathrooms / en suites



POLOCOOL Portable Refrigerated Air Conditioners

- Largest cooling capacity on the market (19,000 BTU)
- Cool areas up to 39 m²
- Simple installation and operation

Please talk to your retailer or contact NOBO for more information on these products.

NOBO AUSTRALIA ABN 80 749 103 558

17 Brett Drive, Carrum Downs, VIC 3201

Free Call 1800 MY NOBO (1800 69 6626)

Fax (03) 9775 1400

www.nobo.com.au

NOBO NEW ZEALAND

P.O. Box 6032, Upper Riccarton, Christchurch 8442

Free Call 0800 088 100

Fax 0800 088 200

www.nobo.co.nz

NOBO

COMFORT YOU DESERVE

DISTRIBUTORS OF NOBO AND POLO HEATING AND COOLING PRODUCTS

