

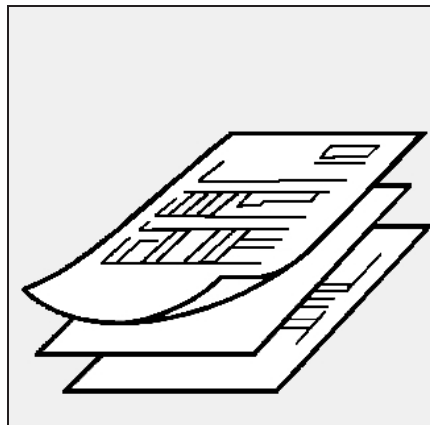

C43, C54 GX507/8



Données techniques
Brûleurs gaz..... 2-7



Dati tecnici
Bruciatori di gas 2-7



Datos técnicos
Quemadores de gas 2-7



Technical data
Gas burners 2-7



Technische Daten
Gasbrenner 2-7



Технические характеристики
Газовые горелки..... 2-7



Pièces de rechange
Pezzi di ricambio
Piezas de recambio
Spare parts list
Ersatzteilliste
Запчасти..... 9-17



Schémas électrique et hydraulique
Schemi elettrico e idraulico
Esquema eléctrico y hidráulico
Electric and hydraulic diagrams
Elektro- und Hydraulikschema
Электрические и гидравлические схемы19-23



Principaux composants / Caratteristiche d'utilisation

Componenti principali / Caratteristiche d'impiego

Componentes principales / Características de utilización

Main components / Characteristics of use

Wichtigste Komponenten / Betriebsdaten

Основные комплектующие / Рабочие характеристики

Principaux composants:

- Coffret de commande et sécurité: SG 513
- Détecteur de flamme: sonde d'ionisation
- Moteur de ventilation: 230V-50Hz, 2800tr/min 480W monophasé condensateur 12µF
- Turbine du ventilateur: Ø180 x 75
- Transformateur d'allumage: 1x11kV
- Commande du volet d'air: servomoteur STA 19
- Manostat d'air: LGW 10 A2

Componenti principali

- Programmatore di comando: SG 513.
- Rilevatore di fiamma: sonda di ionizzazione
- Motore del ventilatore: 230V-50Hz, 2800giri/min 480W monofase condensatore 12µF
- Turbina del ventilatore: Ø180 x 75
- Trasformatore d'accensione: 1x11kV
- Comando serranda aria: servomotore STA 19
- Pressostato dell'aria: LGW 10 A2

Principales componentes

- Cajetín de control y seguridad: SG 513
- Detector de llama: sonda de ionización
- Motor de ventilación: 230V-50Hz, 2800 min⁻¹ 480W monofásico condensador 12µF
- Turbina del ventilador: Ø180 x 75
- Transformador de encendido: 1x11kV
- Control trampilla de aire: servomotor STA 19
- Presostato de aire: LGW 10 A2

Caractéristiques d'utilisation

Température ambiante:

- d'utilisation: -5 ... 40°C
- de stockage: - 20 ..70°C

Tension / Fréquence:

- 230 VAC -15...+10% - 50Hz^{±1%} monophasé

Degré de protection: IP 21

▲ Dans le cas d'une alimentation électrique sans neutre à la terre, installer un transformateur d'isolement de 3.0A/630 VA.

Caratteristiche d'impiego

Temperatura ambiente :

- d'utilizzazione : -5 ...40° C
- di stoccaggio : -20 ...70° C

Tensione / Frequenza :

- 230 VAC -15...+10% - 50 Hz^{±1%} monofase

Grado di protezione : IP 21

▲ In caso di alimentazione elettrica senza neutro collegato a terra, installare un trasformatore d'isolamento di 3.0A/630 VA.

Características de utilización

Temperatura ambiente :

- de utilización : - 5 ...40° C
- de almacenamiento : - 20 ...70° C

Tensión eléctrica / Frecuencia :

- 230 VAC -15...+10% - 50 Hz^{±1%} monofásico

Grado de protección : IP 21

▲ En caso de alimentación eléctrica sin neutro a tierra instalar un transformador de aislamiento de 3.0A/630 VA.

Principaux composants / Caractéristiques d'utilisation
Componenti principali / Caratteristiche d'impiego
Componentes principales / Características de utilización
Main components / Characteristics of use
Wichtigste Komponenten / Betriebsdaten
Основные комплектующие / Рабочие характеристики

Main components

- Control unit :
SG 513
- Flame detector :
ionization probe
- Fan motor:
230V-50Hz, 2800rpm
480W single-phase
capacitor 12µF
- Fan turbine : Ø180 x 75
- Ignition transformer :
1x11kV
- Air flap control :
servomotor STA 19
- Air pressure switch:
LGW 10 A2

Wichtigste Komponenten:

- Feuerungsautomat:
SG 513
- Flammenwächter:
Ionisationssonde
- Gebläsemotor:
230V-50Hz, 2800U/min
480W einphasig
Kondensator 12µF
- Lüfterrad: Ø180 x 75
- Zündtransformator:
1x11kV
- Luftklappensteuerung:
Stellantrieb STA 19
- Luftdruckwächter:
LGW 10 A2

Основные компоненты

- Блок управления
SG 513
- Детектор факела:
ионизационный зонд
- Двигатель воздуходувки:
230В - 50 Гц, 2800 об./мин.
480 Вт одна фаза
конденсатор 12 µF
- Турбина воздуходувки: Ø 180 x 75
- Трансформатор розжига:
1 x 11 кВ
- Управление воздушной заслонкой:
серводвигатель STA 19
- Реле давления воздуха:
LGW 10 A2

Characteristics of use

Ambient temperature :
- for use : - 5... 40° C
- for storage : - 20... 70° C
Voltage / Frequency :
- 230 VAC -15...+10% - 50 Hz^{±1%}
single-phase
Protection level : IP 21

▲With an electrical power supply
without an earthed neutral, install a
3.0 A/630 VA isolation transformer

Betriebsdaten

Umgebungstemperatur :
- Betriebstemperatur : -5...40°C
- Lagerungstemperatur : -20...70°C
Spannung/Frequenz :
- 230 VAC -15...+10% - 50 Hz^{±1%}
einphasig
Schutzart : IP 21

▲Bei einer Stromversorgung ohne
geerdeten Nullleiter einen Isoliertrafo
mit 3.0 A/630 VA installieren.

Рабочие характеристики

Температура окружающего воздуха:
- при эксплуатации: -5 ... 40 °C
- при хранении: - 20 ... 70 °C
Напряжение/Частота:
- 230 В переменного тока -15 ...+10 %
- 50 Гц^{±1%} однофазный
Уровень электрозащиты: IP 21

▲При использовании
электропитания без
заземленной нейтрали
установите изолирующий
трансформатор 3.0 А/630 ВА.

Courbes de puissance
Curve di potenza
Diagramas de potencia
Power graphs
Arbeitsfelder
Рабочие кривые

Composition de la rampe gaz
Composizione della rampa gas
Composiçión de la rampa de gas
Gas manifold composition
Zusammensetzung der Gasarmatur
Состав газовой рампы

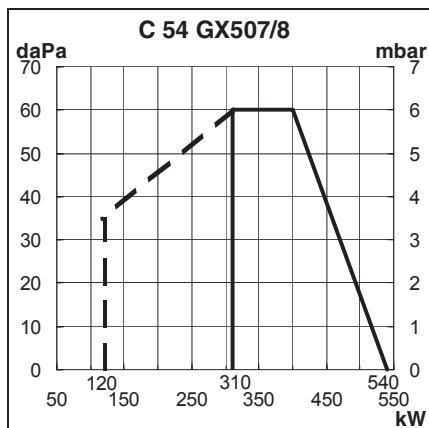
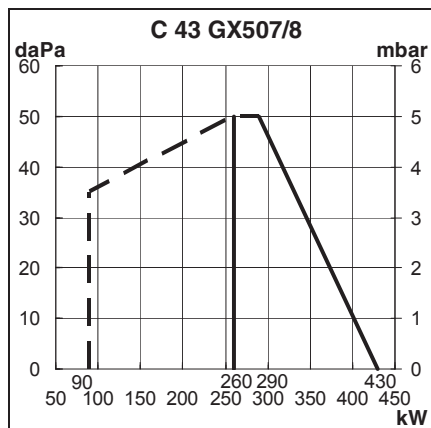

Brûleur Bruciatore Queimador Burner Brenner Горелка	P max P макс. kW кВт	Gaz Gas Gas Gas Gas Газ	P gaz P Gas P Gas P Gas P Gas P Газ	Vanne Valvola Válvula Valve Ventil Клапан	Filtre Filtro Filtro Filter Filter Фильтр			Manostat Manostato Manóstato Press. Switch Druckwächter Регулятор
					MB VEF...	Ø bride Ø flangia Ø brida Ø flange Ø Flansch Ø фланца Rp	Intégré Incorp. Integrado Integrated Interner внутр. FI	
C 43	430	G20	300	407	3/4	FI	1	150A5
		G25	300					
		G31	148					
		G20	20	412	1" 1/4	FI		
		G25	25					
		G31	37					
C 54	540	G20	300	407	3/4	FI	1	
		G25	300					
		G31	148					
		G31	37	420	1" 1/2	FI		
		G20	20					
		G25	25					

Type Tipo Tipo Tipo Type Art Тип	Groupe Gruppo Grupo Group Gruppe Группа	Pression de distribution Pressione di distribuzione Presión de distribución Distribution pressure Eingangsdruk Давление на входе			Hi à 0°C et 1013 mbar Hi a 0°C e 1013 mbar Hi à 0°C y 1013 mbar Hi at 0°C and 1013 mbar Hi bei 0°C und 1013 mbar Hi при 0°C и 1013 мбар		Gaz Gas Gas Gas Gas Газ
		Pn mbar мбар	Pmin mbar мбар	Pmax mbar мбар	min (kWh/m ³) (кВтч/м ³)	max (kWh/m ³) (кВтч/м ³)	
Gaz H Gas H	2H	20 300	17 240	25 360	9,5	11,5	G20
Gaz L Gas L	2L	25 300	20 240	30 360	8,5	9,5	G25
Gaz P Gas P	3P	37 148	25 100	45 180	24,5	26,5	G31

Puissance kW Potenza kW Potencia kW Power kW Leistung kW Мощность кВт		C43GX507/8				C54GX507/8			
		min	G20 p20/p300 max	G25 p25/p300 max	G31 p37/p148 max	min	G20 p20/p300 max	G25 p25/p300 max	G31 p37/p148 max
		мин.	макс.	макс.	макс.	мин.	макс.	макс.	макс.
Brûleur	(kW)	260	430	430	430	310	540	540	540
Min. 1 ^{ère} allure	(kW)	90	---	---	---	120	---	---	---
Générateur	(kW)	239	396	396	396	285	497	497	497
Débit nominal réel de gaz à 15°C et 10.13 mbar									
Naturel groupe H Hi =9,45	m³/h (kWh/m³)	27,5	45,5	---	---	32,8	57,1	---	---
Naturel groupe L Hi =8,13	m³/h (kWh/m³)	32,0	---	52,9	---	38,1	---	66,4	---
Propane P Hi =24,44	m³/h (kWh/m³)	10,6	---	---	17,6	12,7	---	---	22,1
Masse volumique kg/m³ = 1,98									
Bruciatore	(kW)	260	430	430	430	310	540	540	540
Min. 1. stagio	(kW)	90	---	---	---	120	---	---	---
Generatore	(kW)	239	396	396	396	285	497	497	497
Portata nominale eff. di gas a 15°C e 10.13 mbar									
Naturale gruppo H Hi =9,45	m³/h (kWh/m³)	27,5	45,5	---	---	32,8	57,1	---	---
Naturale gruppo L Hi =8,13	m³/h (kWh/m³)	32,0	---	52,9	---	38,1	---	66,4	---
Propano P Hi =24,44	m³/h (kWh/m³)	10,6	---	---	17,6	12,7	---	---	22,1
Massa volumica kg/m³ = 1,98									
Quemador	(kW)	260	430	430	430	310	540	540	540
Min. 1a etapa	(kW)	90	---	---	---	120	---	---	---
Generador	(kW)	239	396	396	396	285	497	497	497
Caudal nominal real de gas a 15°C y 10.13 mbar									
Natural grupo H Hi =9,45	m³/h (kWh/m³)	27,5	45,5	---	---	32,8	57,1	---	---
Natural grupo L Hi =8,13	m³/h (kWh/m³)	32,0	---	52,9	---	38,1	---	66,4	---
Propano P Hi =24,44	m³/h (kWh/m³)	10,6	---	---	17,6	12,7	---	---	22,1
Densidad kg/m³ = 1,98									
Burner	(kW)	260	430	430	430	310	540	540	540
Min. 1 st stage	(kW)	90	---	---	---	120	---	---	---
Generator	(kW)	239	396	396	396	285	497	497	497
Actual gas flow rate at 15°C and 10.13 mbar									
Natural group H Hi =9.45	m³/h (kWh/m³)	27,5	45,5	---	---	32,8	57,1	---	---
Natural group L Hi =8.13	m³/h (kWh/m³)	32,0	---	52,9	---	38,1	---	66,4	---
Propane P Hi =24.44	m³/h (kWh/m³)	10,6	---	---	17,6	12,7	---	---	22,1
Voluminal mass kg/m³ = 1,98									
Brenner	(kW)	260	430	430	430	310	540	540	540
Min. 1. Stufe	(kW)	90	---	---	---	120	---	---	---
Kessel	(kW)	239	396	396	396	285	497	497	497
Effektiver Gasdurchsatz bei 15°C und 10.13 mbar									
Erdgas Gruppe H Hi =9,45	m³/h (kWh/m³)	27,5	45,5	---	---	32,8	57,1	---	---
Erdgas Gruppe L Hi =8,13	m³/h (kWh/m³)	32,0	---	52,9	---	38,1	---	66,4	---
Flüssiggas P Hi =24,44	m³/h (kWh/m³)	10,6	---	---	17,6	12,7	---	---	22,1
Dichte kg/m³ = 1,98									
Горелка	(кВт)	260	430	430	430	310	540	540	540
Мин. Мощность розжига	(кВт)	90	---	---	---	120	---	---	---
Котел	(кВт)	239	396	396	396	285	497	497	497
Эффект. расход газа при 15°C									
Природный газ группы H Hi =9,45	m³/ч (кВтч/м³)	27,5	45,5	---	---	32,8	57,1	---	---

**Encombrement Dimensions
Dimensioni d'ingombro
Dimensiones Medidas
Space requirements and dimensions
Maßbild und Abmessungen
Занимаемый объем Размеры**

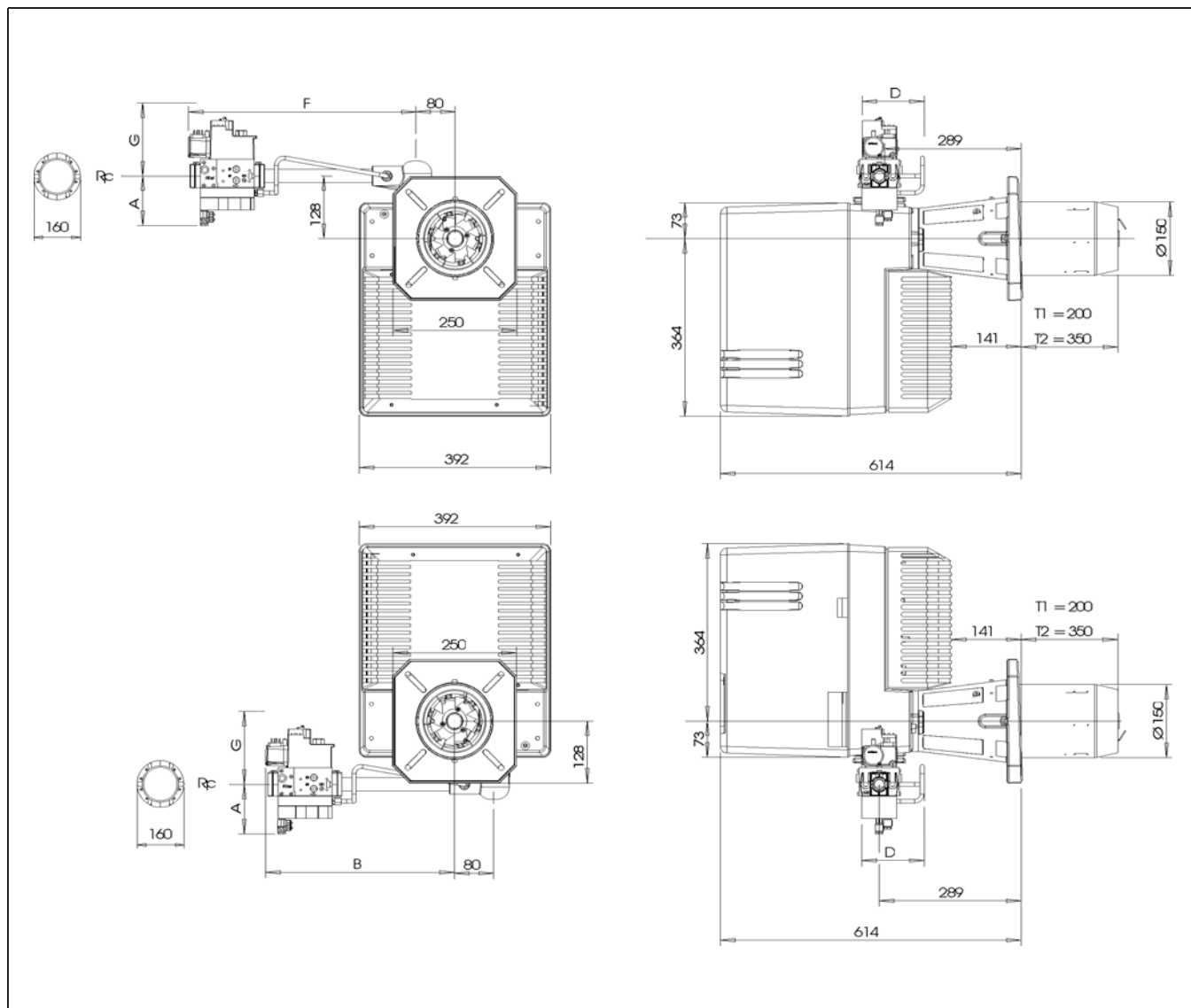

	A	B	D	F	G	Rp
p148-300	105	390	125	470	150	3/4"
p20-25-37	100	420	145	500	170	1" 1/4
p20-25	125	440	145	520	220	1" 1/2

Pour l'implantation volute en bas :

lire les informations complémentaires au paragraphe "Installation" montage du brûleur.

Per l'installazione con la voluta verso il basso:

leggere le informazioni complementari al paragrafo "Installazione", montaggio del bruciatore.

Para colocar la voluta hacia abajo :

leer las informaciones complementarias en el párrafo "Instalación" montaje del quemador.

For setting-up with the spiral at bottom :

read the additional information in the "Assembly" paragraph of the burner installation instructions.

Für den Einbau mit nach unten gerichtetem Lüfterrad :

Die ergänzenden Informationen des Kapitels "Installation" "Montage des Brenners beachten.

При установке спирали снизу:

см. дополнительную информацию в разделе "Установка" Монтаж горелки.

Encombrement Dimensions Dimensioni d'ingombro Dimensiones Medidas Space requirements and dimensions Maßbild und Abmessungen Занимаемый объем Размеры

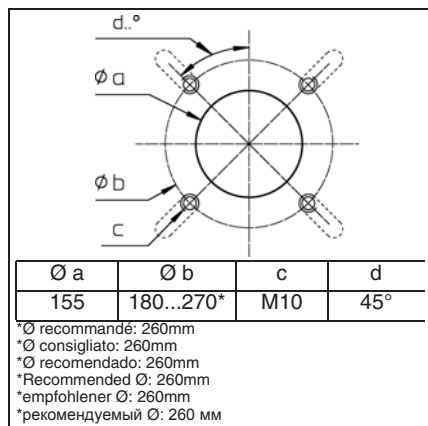

Encombrement et dimensions

Respecter une distance libre minimum de 0,6 mètre de chaque côté du brûleur pour permettre les opérations de maintenance.

Ventilation chaufferie

Le volume d'air neuf requis est de 1,2 m³/kWh produit au brûleur.

Rampe gaz

S'implante uniquement à l'horizontale à **droite** ou à gauche.

Dimensioni d'ingombro

Lasciare uno spazio libero minimo di 0,6 metri su ogni lato del bruciatore per consentire le operazioni di manutenzione.

Ventilazione locale caldaia

La portata dell'aria di ricambio del locale deve essere almeno di 1,2 m³/kWh bruciatore.

Rampa gas

Deve essere installata unicamente in orizzontale a **destra** o a sinistra.

Dimensiones y medidas

Respetar una distancia libre mínima de 0,6 metros a ambos lados del quemador para permitir las operaciones de mantenimiento.

Ventilación calentador

El volumen de aire nuevo requerido es de 1,2 m³/kWh producido en el quemador.

Rampa de gas

Sólo se coloca en horizontal a la **derecha** o a la izquierda.

Space requirements and dimensions

Leave a space of at least 0.6 metres on each side of the burner for maintenance purposes.

Boiler-house ventilation

Volume of fresh air required is 1.2 m³/kWh produced at the burner.

Gas manifold

Can only be installed horizontally, on the **right** or on the left.

Maßbild und Abmessungen

Für Servicearbeiten ist ein freier Abstand von min. 0,6 m auf jeder Seite des Brenners sicherzustellen.

Heizraumbelüftung

Die nötige Frischluftzufuhr beträgt 1,2 m³/kWh am Brenner.

Gasarmaturgruppe

Montage waagrecht **rechts** oder links möglich.

Занимаемый объем и размеры

Обеспечьте свободное пространство минимум 0,6 м с каждой стороны горелки для осуществления работ по ее обслуживанию.

Вентиляция котла

Требуемый объем приточного воздуха для производительности горелки 1,2 м³/кВтч.

Газовая рампа

Устанавливается только в горизонтальном положении с **правой** или левой стороны.



Pièces de rechange
Pezzi di ricambio
Piezas de recambio
Spare parts list
Ersatzteilliste
Запчасти

C43, C54 GX507/8



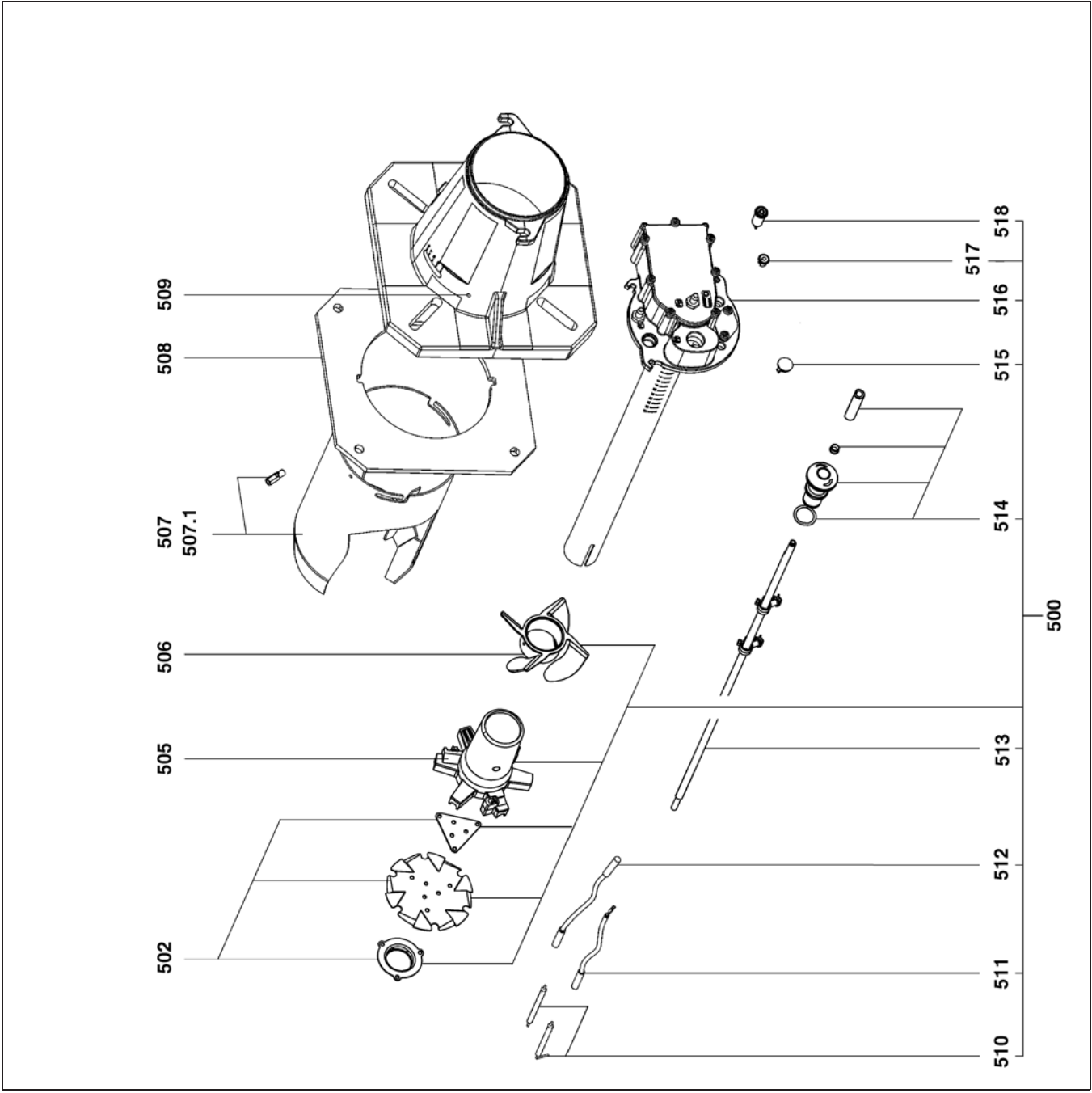

Pos.	Désignation	Denominazione	Designación	Description	Bezeichnung	Назначение	N° Art.
500	Ligne gaz complète C43 GX 507/8 T1 T2	Linea gas completa	Linea gas	Complete gas line	Lanzengaskopf	Газовая линия к соплу	
502	Kit défl.+ diffus.+ obturateur	Set deflectore + diffusore + otturatore	Kit de defl. + difus. + obturador	Set turbulator+ diffuser + shutter	Set Defl. + Diffus.+ Verschluss	Комплект дефлектор + диффузор + заслонка	13 016 251
505	Etoile répart. gaz	Ripartitore gas	Estrella gas	Star gas head	Sterngaskopf	Звездочка распределения газа	
506	Turbulateur	Turbulatore	Turbulador	Helic.turbulator	Stauscheibe	Турбулизатор	
507	Embout + vis	Imbuto + viti	Cañon + Tornillo	Blast tube + screws	Brennerrohr + Schrauben	Комплект + винтов	
	C43 x 268 T1 x 418 T2						13 015 919 13 015 920
	C54 x 268 T1 x 418 T2						13 015 879 13 015 881
507.1	Levier rotation embout	Leva rotazione imbuto	Palanca de rotación de la contera	Blast tube rotat. lever	Hebel Flammrohrdrehung	Рычаг поворота насадки	
508	Joint/façade chaudière	Guarnizione/ sportello della caldaia	Junta/frontal de la caldera	Flange klangerit	Dichtung/ Kesselanschlusßplatte	Уплотнительная прокладка/внешняя сторона котла	13 016 214
509	Vis M6 (à gauche) fixation embout 3x	Vite M6 (alla sinistra) fissazione imbuto	3 tornillos M6 (a izquierda) para la fijación de la contera	Screw M6 (left hand thread) flame tube	Schraube M6 (linksgewinde) Befestigung Flammrohr 3x	Винт M6 (слева) крепления насадки 3x	13 016 777
510	Sonde d'ionisation + électrode allu.	Sonda di ionizzazione + elettrodo di accens.	Sonda de ionización + electrodo de encendido	Ionisation probe + ignition electrode	Ionisationssonde + Zündelektrode	Ионизационный + запальный электрод	13 015 841
511	Câble d'ionisation L.700	Cavo di ionizzazione	Cable sonda de ionización	Ionisation cable	Ionisationskabel	Кабель ионизационного	13 015 625
512	Câble d'allumage L.1050	Cavo accensione	Cable de encendido	Ignition lead	Zündkabel	Кабель розжига	13 015 610
513	Tige de réglage Lg. 646 T1 Lg. 796 T2	Asta di regolazione	Varilla de ajuste	Adjust linkage	Regulierstange	Регулировочный стержень	
514	Bouton de cde ligne gaz	Bottone di comando linea porta gas	Botón de mando de la línea de gas	Adjust knob	Bedienungsknopf Lanzengaskopf	Кнопка управления газовым трактом	13 016 854
515	Voyant de flamme	Spia di fiamma	Testigo de llama	Sight glass	Schauglas	Глазок для контроля пламени	
516	Coude gaz Lg. 496 T1 Lg. 646 T2	Curva gas	Codo gas	Lance gas head	Messnippel-Winkel Gas	колено газ	
517	Passerelle	Passacavo	Capuchón de goma	Rubber funnel	Tülle	Насадка	
518	Douille BI 6.3	Manicotto	Casquillo	Measure socket	Hülse	Втулка	



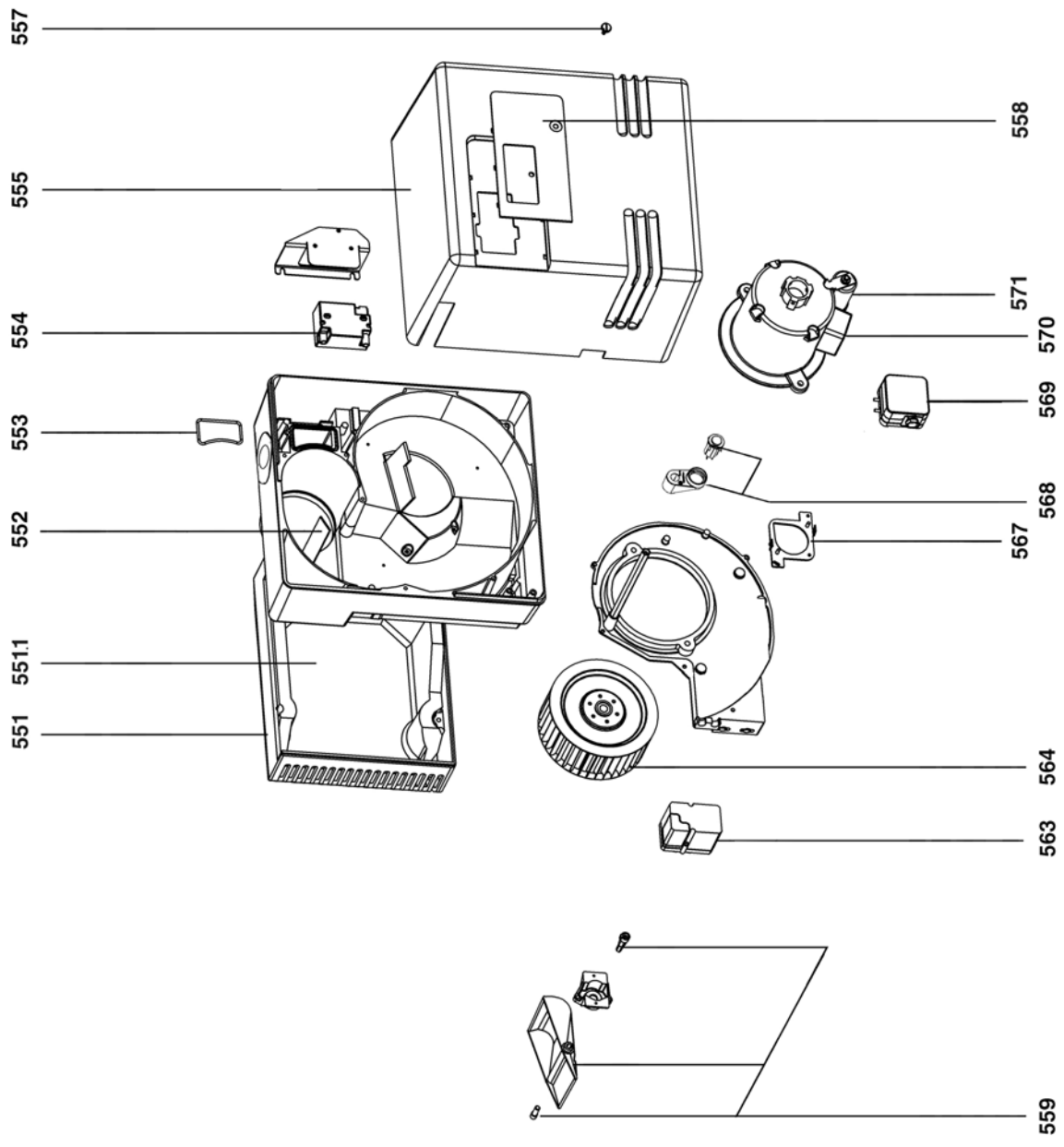

Pos.	Désignation	Denominazione	Designación	Description	Bezeichnung	Назначение	N° Art.
550	Corps	Corpo	Bloque	Body	Körper	Корпус	
551	Boîte à air	Scatola d'aria	Caja de aire	Air damper	Luftkasten	Воздушная коробка	
552	Guide d'air	Guida d'aria	Guía de aire	Air guiding piece	Luftführung	Воздуховод	
553	Joint O'Ring / raccord. gaz	O'Ring / raccordo gas	Junta O'Ring / conex. de gas	Flange / gas connection	O'Ring / Gasanschluss	Кольцевой уплотнитель / газовый штуцер	
554	Transformateur EBI - 1x11kV	Trasformatore d'accensione	Transformador	Ignition transformer	Zündtrafo	Трансформатор розжига	13 016 668
555	Capot orange équipé	Coperchio arancio	Tapa naranja	Orange cover cpl.	Schützhaube	Оранжевый кожух	13 015 653
557	Vis / capot	Vite / coperchio	Tornillo / tapa	Oval head screw	Befestigungsschraube	Крепежный винт	13 016 776
558	Plaque frontale	Marchio frontale	Placa frontal	Front plate	Beschriftungsplatte	Лицевая панель	13 016 399
559	Volet air + axes	Serranda aria + assi	Trampilla de aire + ejes	Air flap + axes	Luftklappen + Achsen	Воздушная заслонка + стержни	13 016 780
560	Support servomoteur	Supporto servomotore	Soporte del servomotor	Servomotor stand	Halter für Stellantrieb	Опора серводвигателя	
563	Servomoteur air C43/54 GX 507/8 STA 19	Servomotore aria	Servomotor aire	Servomotor air	Servomotor Luft	Воздушная серводвигатель	13 016 568
564	Turbine Ø 180/75	Ventilatore	Turbina	Air fan	Ventilatorrad	Турбина	13 016 705
567	Support pressostat	Supporto pressostato	Soporte del presostato	Press.contr. device stand	Halter Druckwächter	Кронштейн реле давления	
568	Ensemble réarmement	Riarmo	Conjunto de reinicio	Release system	Entriegelungsset	Узел приведения в рабочее положение	13 016 250
569	Pressostat LGW 10 A2	Pressostato	Presostato	Pressure control device	Luftdruckwächter	Реле давления	13 016 342
570	Moteur de ventilation C43/54	Motore di ventilazione	Motor de ventilación	Fan motor	Gebälsemotor	Двигатель воздухоудвки	13 016 377
571	Condensateur 12µF	Condensatore	Condensador	Condensator	Kondensator	Конденсатор	13 015 715



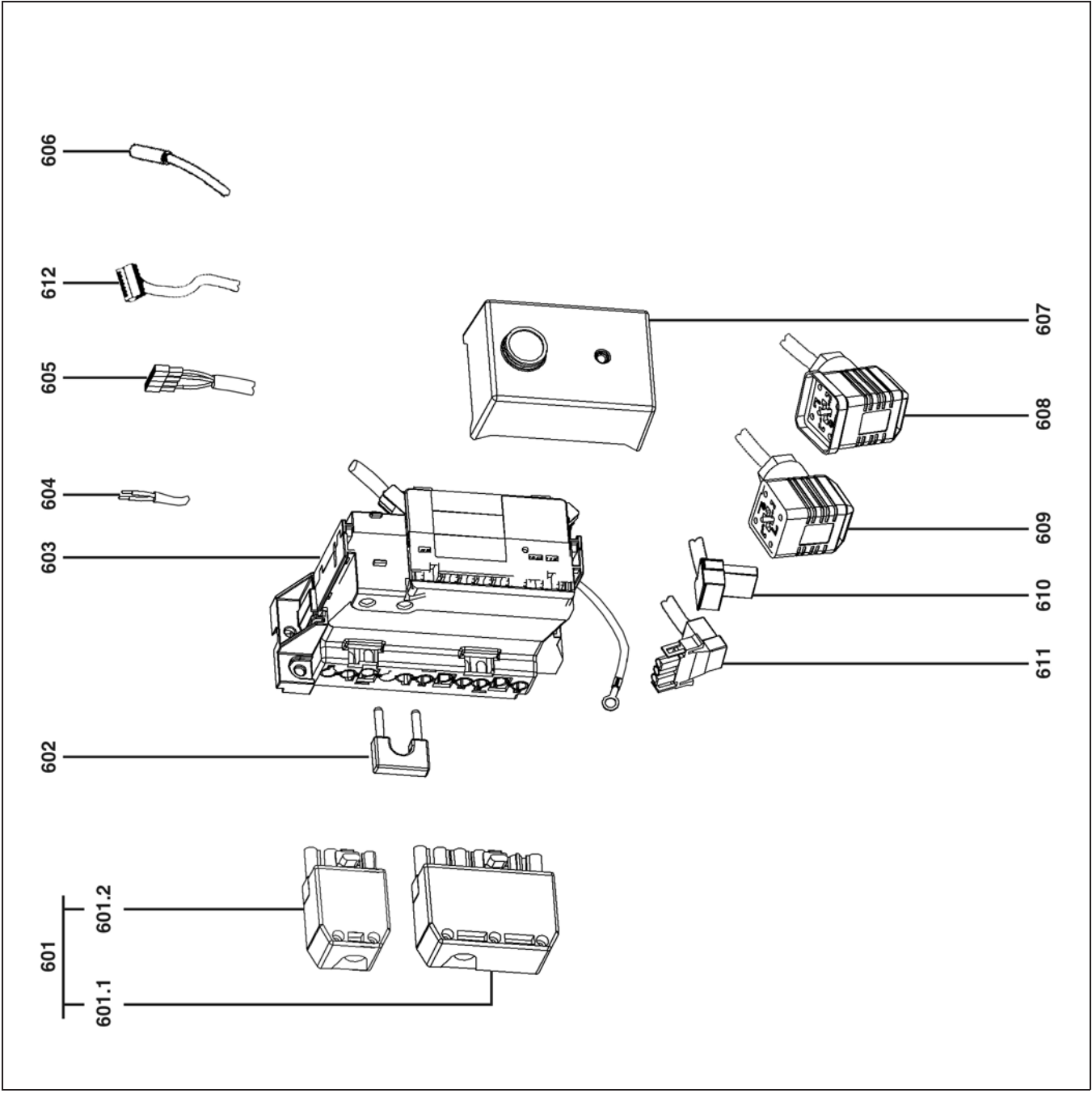

Pos.	Désignation	Denominazione	Designación	Description	Bezeichnung	Назначение	N° Art.
601	Prise Wieland 4P.+ 7P	Presa Wieland 4P. + 7P.	Toma Wieland 4P. + 7P.	Plug Wieland 4P. + 7P.	Kabel m. Stecker 4P. + 7P.	Кабель со штекером 4P. + 7P.	13 016 496
601.1	Prise Wieland 7P.	Presa Wieland 7P.	Toma Wieland 7P.	Plug Wieland 7P.	Kabel m. Stecker 7P.	Кабель со штекером 7P.	13 016 494
601.2	Prise Wieland 4P.	Presa Wieland 4P.	Toma Wieland 4P.	Plug Wieland 4P.	Kabel m. Stecker 4P.	Кабель со штекером 4P.	13 016 489
602	Pont de ionisation	Punto di misura	Puente de ionización	Connection for ionisation	Verbindungsstecker	Ионизационный мост	13 016 455
603	Cassette raccord. G1/2/5	Cassetta de collegamento	Cassete de conexión	Elec. connection box	Anschlußkasten mit Relaissockel ohne Kabel	Кабельная коробка для подключения различных электроприборов к горелке	13 015 684
604	Câble manostat air	Cavo manostato aria	Cable manostato aire	Press. cont. devise cable	Kabel Luftdruckwächter	Кабель воздушная регулятора	13 015 627
605	Câble/bouton réarmement	Cavo/riarmo	Cable torta/ cajetín de control	Cable / release	Kabel m. Stecker / Entriegelung	Кабель со штекером для кнопки сброса	13 015 613
606	Câble ionisation/cassette	Cavo ionizzazione/cassetta	Cable ionización/cassete	Ionisation cable / box plug	Ionisationskabel/ Anschlußkasten	Кабель ионизационного/ ионизационного/	13 016 467
607	Coffret SG5xx	Programmatore	Cajetín	Control unit	Feuerungsautomat	Блок безопасности	13 015 700
608	Câble vanne gaz	Cavo valvola gas	Cable válvula gas	Gas valve cable	Kabel Gasventil ohne Trennrelais	Кабель газового клапана	13 015 642
609	Câble manostat gaz	Cavo manostato gas	Cable manostato gas	Pressure control device cable	Kabel Gasdruckwächter	Кабель газового регулятора	13 015 628
610	Câble transfo éq. C43/C54	Cavo trasformatore	Cavo transformador	Transformer cable	Kabel Zündtrafo	Кабель Трансформатор розжига	13 015 639
611	Câble moteur	Cavo motore	Cavo motor	Motor cable	Kabel Motor	Кабель двигатель	13 015 629
612	Câble servomoteur éq.	Cavo servomotore	Cavo servomotor	Cable 9P servomotor eq.	Kabel Servomotor	Кабель Серводвигатель	13 015 634



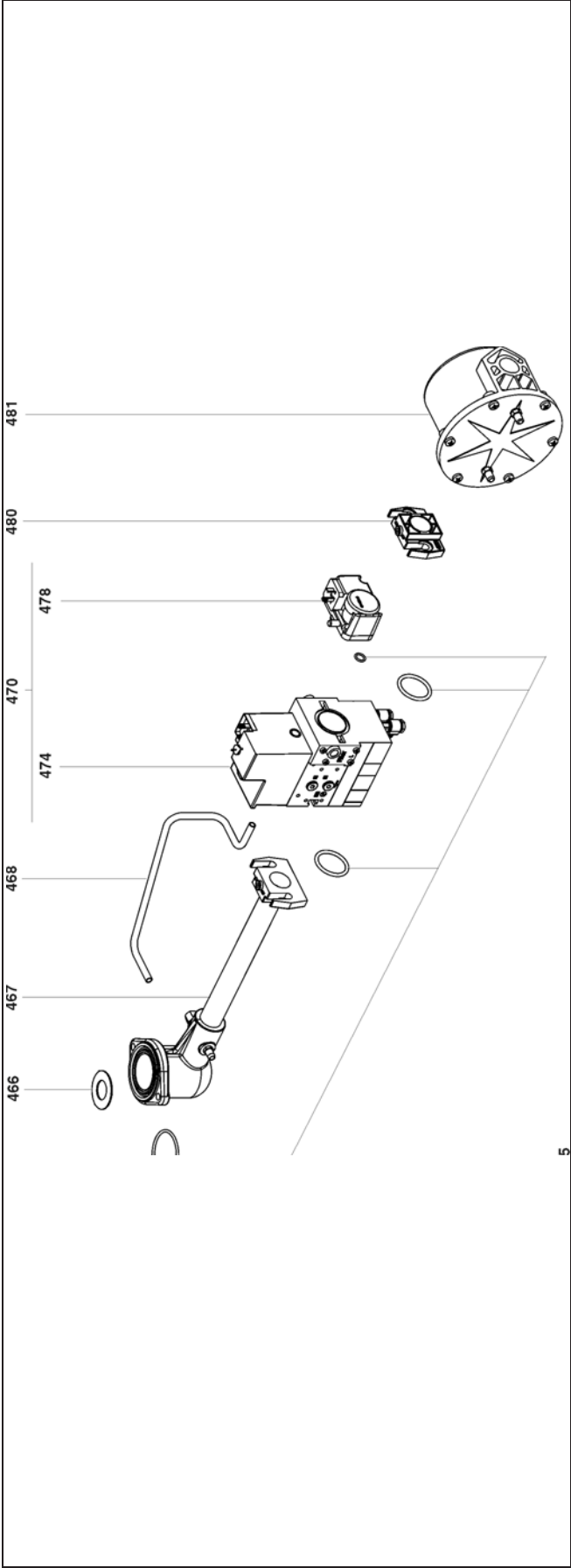

5

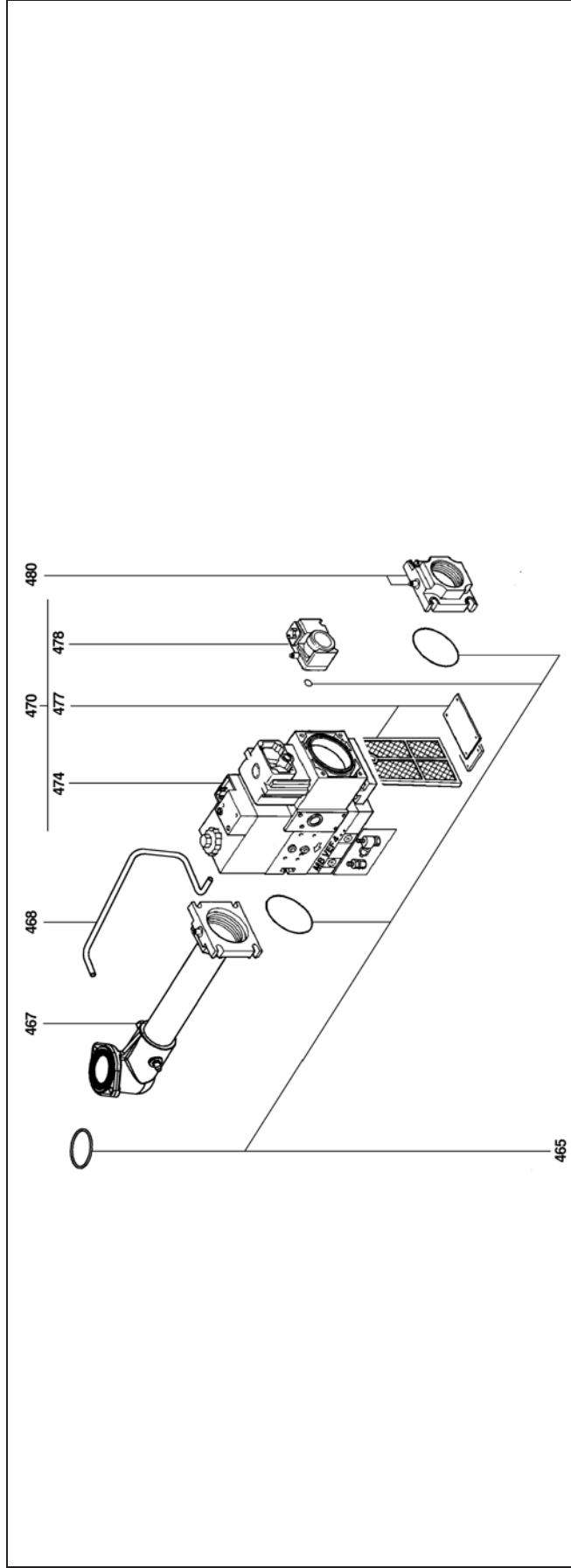

465

Pos.	Désignation	Denominazione	Designación	Description	Bezeichnung	Назначение	N° Art.
400	Rampe gaz	Rampa gas	Rampa de gas	Gas valve assembly	Gasarmatur	Газовая рампа	
1	MBVEF 407						
2	MBVEF 412						
3	MBVEF 420 FI						
4	MBVEF 420 FP						
465	Kit joints O'Ring	Set O'Ring	Kit juntas O'Ring	O'Ring set	O'Ring-set	Кольцо круглого сечения / фланец	
1	MBVEF 407						13 011 313
2	MBVEF 412						13 011 314
3, 4	MBVEF 420						13 016 259
466	Diaphragme	Diaframma	Diafragma	Orifice restricting piece	Blende	Перегородка	
467	Collecteur monté	Collettore	Colector	Gas tube eq.	Gasanschlussrohr Kpl.	Коллектор в сборе	
1	Rp 3/4						
2	Rp 1"1/4						
3, 4	Rp 1"1/2						
468	Tube pression gaz	Tubo pressione gas	Tubo presión gas	Gas pressure tube	Gasrohr	Газовая трубка	
470	Vanne	Valvola	Válvula	Valve	Gasventil	Задвижка основного обмена	
1	MBVEF 407 B01S30						13 016 763
2	MBVEF 412 B01S10						13 016 720
3	MBVEF 420 B01S10 +FI						13 016 723
4	MBVEF 420 B01S10 +FP						13 016 725
474	Bobine VS+ VA	Bobina	Bobina	Magnetic coil	Magnetspule	Катушка	
1	N°1105						13 015 555
2	N°1205						13 015 560
3, 4	N°1215						13 015 561
477	Élément filtrant pour filtre poche	Elemento filtrante per filtro tasca	Elemento filtrante para el filtro bolsillo	Filter medium for pocket filter	Filterelement für Taschenfilter	Фильтрующий элемент встроенного фильтра	13 015 859
478	Pressostat gaz GW150A5	Pressostato gas	Presostato gas	Gas pressure switch	Gasdruckwächter	Газового реле давления	13 016 461
480	Bride/MB	F langia/MB	Brida/MB	Flange/MB	Flansch/MB	Фланец/MB	
1	407 Rp 3/4'						13 015 585
2	412 Rp 1"1/4						13 015 586
3, 4	420 Rp 1"1/2						13 015 587
481	Filtre extérieur Rp1	Filtro esterno Rp1	Filtro exterior Rp1	External filter Rp1	ausseres Filter Rp1	Наружный фильтр Rp 1	13 016 006
481.1	Élément filtrant Rp1	Elemento filtrante Rp1	Elemento filtrante Rp1	Filter medium Rp1	Filterelement Rp1	Фильтрующий элемент Rp1	13 015 863



Schémas électrique et hydraulique
Schemi elettrico e idraulico
Esquema eléctrico y hidráulico
Electric and hydraulic diagrams
Elektro- und Hydraulikschemata
Электрические и гидравлические схемы

C43, C54 GX507/8



Y12 Sicherheitshauptgasventil
Vanne gaz de sécurité
Safety valve

Y13 Hauptventil (Gas)
Vanne gaz principale
Main gas valve

F4 Gasdruckwaechter min.
Manostat gaz mini
Min. gas pressure switch

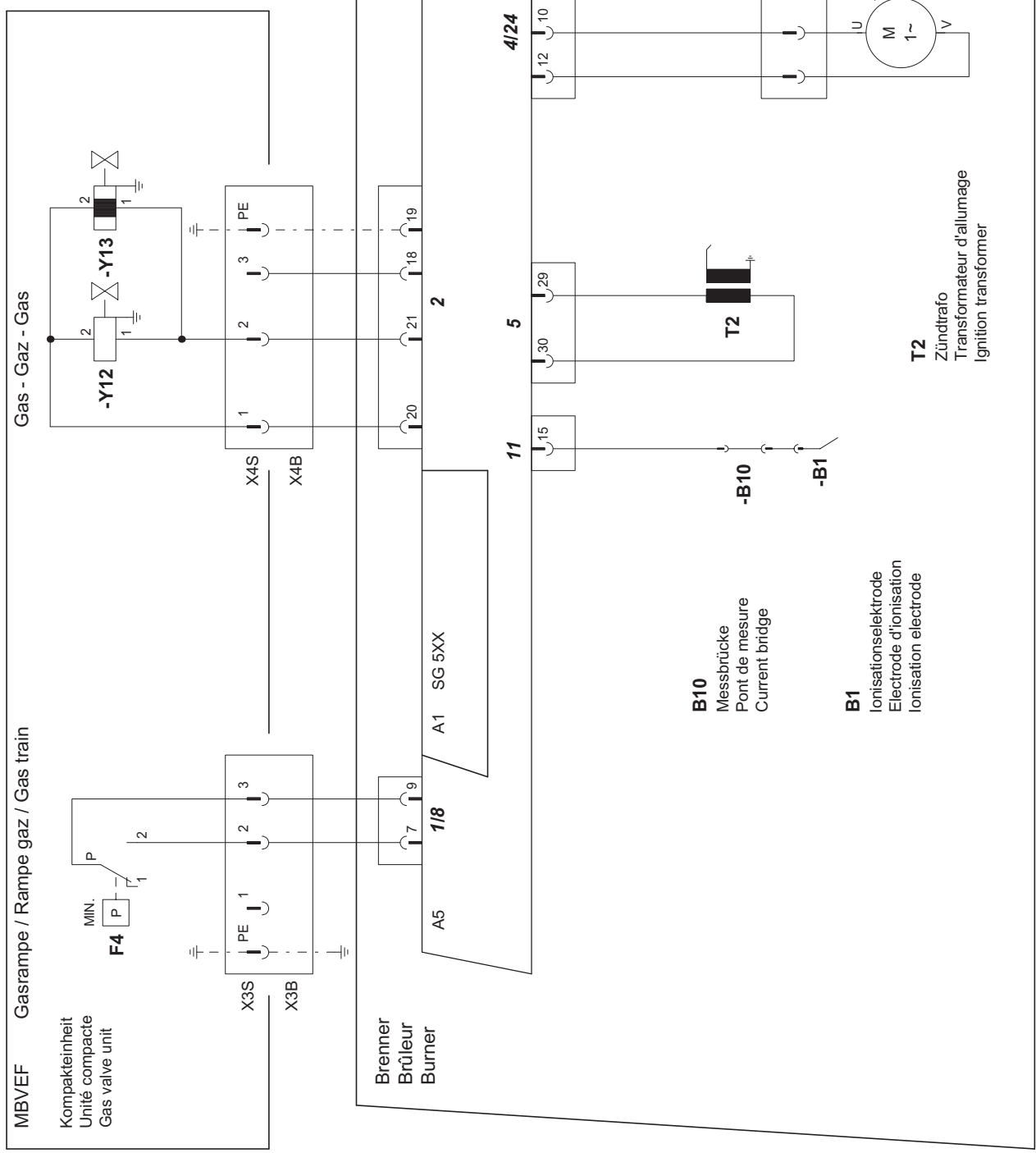

B10 Messbrücke
Pont de mesure
Current bridge

B1 Ionisationselektrode
Electrode d'ionisation
Ionisation electrode

T2 Zündrafo
Transformateur d'allumage
Ignition transformer

M1 Brennemotor
Moteur du brûleur
Burner motor

Aend./Modification	Dat.	Vis.	Dat.	Vis.	Art. N°:	Type	Blatt / Page
a	AM 9554	03.01.02			13010803.D	C 43/54 GX507/8	2
b	AM 9695	03.07.02	gez. des.	cod	Bez./Des.1	Schéma électrique	Tot. Bl / Pg
c	AM 9890	27.03.03	gepr. Contr.		Bez./Des.2	Brûleur gaz AGP	3
d	AM 10859	05.09.07	Miz			G03.1.0242	



A

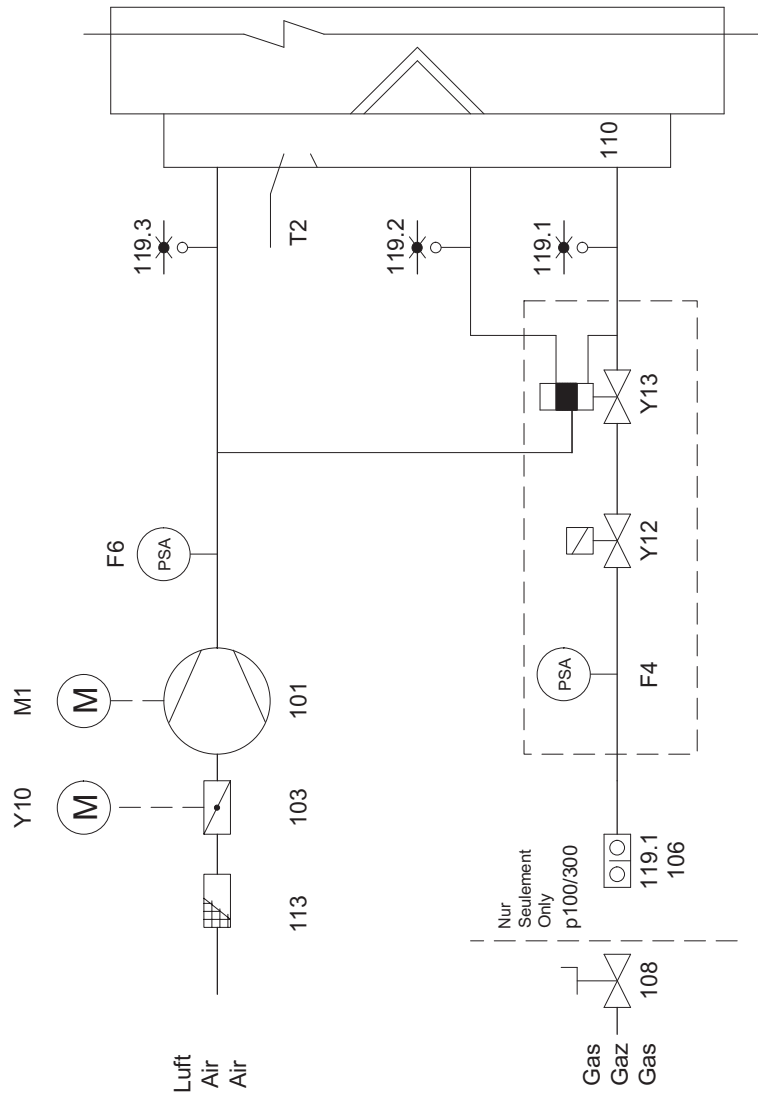

Code	Gasdruckwächter min.	Manostat gaz min.	Manostat d'air	Min gas pressure switch
F4	Luftdruckwächter	Manostat gaz min.	Manostat d'air	Air pressure switch
M1	Brennermotor	Moteur du brûleur	Moteur du brûleur	Burner motor
T2	Zündtrafo	Transfo.	Transfo.	Ignition transfo.
Y10	Stellantrieb	Servomoteur	Servomoteur	Damper motor
Y12	Sicherheitsgasventil	Vanne gaz de sécurité	Vanne gaz de sécurité	Safety gas valve
Y13	Gasventil gassetig	Vanne gaz principale	Vanne gaz principale	Gas valve burner side
101	Ventilator	Ventilateur	Ventilateur	Impeller
103	Luftklappe	Volet d'air	Volet d'air	Air-damper
106	Filter	Filtere	Filtere	Filter
108	Handventil	Vanne manuelle quart de tour	Vanne manuelle quart de tour	Manual valve
110	Gasinjektor	Injecteur gaz	Injecteur gaz	Gas injector
113	Ansauggitter	Grille d'aspiration	Grille d'aspiration	Protection
119.1	Messnippel Gas	Prise pression gaz	Prise pression gaz	Pressure pickup Gas
119.2	Messnippel Feuerraum	Prise pression foyer	Prise pression foyer	Pressure pickup furnace
119.3	Messnippel Luft	Prise pression air	Prise pression air	Pressure pickup air







CUENOD
18 rue des Buchillons
F – 74100 Annemasse