

GCS9 SERIES UNITS

I - INTRODUCTION

GCS9 units were introduced in 1979. They are designed for rooftop installation with optional roof mounting frame and power saver. PG9-120 and PG9-150 power burners are used. Unit options are listed in Table 1. Figure 1 shows a GCS9 cutaway.

If a hard start kit is necessary on single phase units, refer to the "Cross Reference Section" of the Lennox Repair Parts Handbook.

TABLE 1

Description	Model No.
Optional Roof Mounting Frame	RMFG9-65
Optional Power Saver & Controls	PSDG9-65
Optional Ceiling Supply & Return Transitions	SRTG9-65
Optional Ceiling Supply & Return Step-Down Diffuser	RTD9-65
Optional Ceiling Supply & Return Flush Diffuser	FD9-65
Optional Minimum Fresh Air Dampers (Manual and no. & size of filters (in.))	OADG9-65 - (1 26 x 31 x 1)
Optional Automatic Fresh Air Damper Kit	41C55
Optional Ceiling Supply & Return Plenum	SRPG9-65

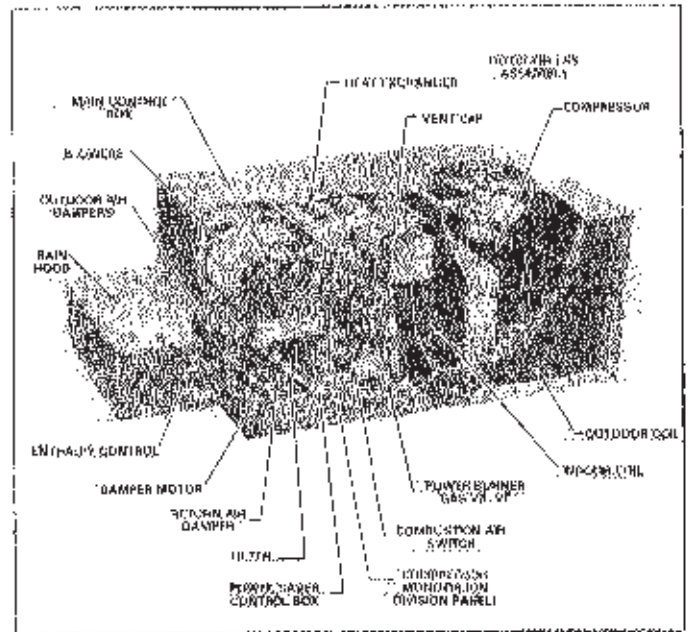

FIGURE 1

II - UNIT INFORMATION

A - Specifications

Model No.	GCS9-411-90	GCS9-411-120	GCS9-461-90	GCS9-461-120
	GCS9-413-90	GCS9-413-120	GCS9-463-90	GCS9-463-120
Heating capacity input (Btu/h)	90,000	120,000	90,000	120,000
Heating capacity burner output (Btu/h)	69,500	93,000	69,600	93,000
★ARI Standard 270 SRN		20		20
*ARI Standard 210		34,000		41,000
Total cooling capacity (Btu/h)		4100		4700
†SEER (Btu/Watts)		8.3		8.8
Dehumidifying capacity		24%		24%
Refrigerant (R-22) charge		6 lbs.		9 lbs. 2 oz.
Evaporator Blower	Blower wheel nominal diam. x width (in.)	(2) 9 x 7		(2) 9 x 7
	Motor horsepower	1/2		1/2
Evaporator Coil	Net face area (sq. ft.)	4.69		5.21
	Tube diam. (in.) & No. of rows	1 1/2 - 3		1 1/2 - 3
	Fins per inch	13		13
Condenser Coil	Net face area (sq. ft.)	15.0		15.0
	Tube diam. (in.) & No. of rows	3/8 - 1		3/8 - 2
	Fins per inch	20		20
Condenser Fan	Diameter (in.) & No. of blades	24 - 4		24 - 4
	Air volume (cfm) (factory setting)	4000		4000
	Motor horsepower	1/4		1/4
	Motor watts (factory setting)	350		375
Number & size of filters (in.)		(2) 20 x 20 x 1		(2) 20 x 20 x 1
Gas piping connection mpt (in.) Natural		1/2		1/2
Recommended gas supply pressure (w.c. - in.) Natural		6		6
Condensate drain size mpt (in.)		3/4		3/4
Net weight of basic unit (lbs.) — 1 Package		735		775

* As defined by Department of Energy Thermal Efficiency Test

† Rated in accordance with ARI Standard 270.

* Rated in accordance with ARI Standard 210; 450 cfm (maximum) evaporator air volume per ton of cooling capacity, 95F outdoor air temperature and 85F db/67F wb entering evaporator air.

Model No.		GCS9-511-120	GCS9-511-150	GCS9-651-120	GCS9-651-150
Heating capacity input (Btuh)		120,000	150,000	120,000	150,000
Heating capacity netnet output (Btuh)		93,000	119,000	93,000	119,000
★ARI Standard 270 SRN					
*ARI Standard 210 Ratings	Total cooling capacity (Btuh)	21	20	21	20
	Total unit watts	47,000	56,000	47,000	56,000
	1*SEER (Btuh/Watts)	5.800	6.900	5.800	6.900
	Dehumidifying capacity	8.3	8.2	8.3	8.2
Refrigerant (R 22) charge		26%	23%	26%	23%
Evaporator Blower		10 lbs	14 lbs	10 lbs	14 lbs
Evaporator Coil	Blower wheel nominal diam. x width (in.)	(21.10 x 6	(21.10 x 6	(21.10 x 6	(21.10 x 6
	Motor horsepower	3/4	3/4	3/4	3/4
	Net face area (sq. ft.)	5.73	6.51	5.73	6.51
Condenser Coil	Tube diam. (in.) & No. of rows	1/2 - 3	1/2 - 3	1/2 - 3	1/2 - 3
	Fins per inch	13	13	13	13
	Net face area (sq. ft.)	15.0	15.0	15.0	15.0
Condenser Fan	Tube diam. (in.) & No. of rows	3/8 - 2	3/8 - 3	3/8 - 2	3/8 - 3
	Fins per inch	20	20	20	20
	Diameter (in.) & No. of blades	24 - 4	24 - 4	24 - 4	24 - 4
Number & size of filters (in.)	Air volume (cfm) (factory setting)	4000	4000	4000	4000
	Motor horsepower	1/4	1/4	1/4	1/4
	Motor watts (factory setting)	375	375	375	375
Gas piping connection mpt (in.) Natural		1/2	1/2	1/2	1/2
Recommended gas supply pressure (wc - in.) Natural		6	6	6	6
Condensate drain size mpt (in.)		3/4	3/4	3/4	3/4
Net weight of basic unit (lbs) - 1 Package		785	835	785	835

† As defined by Department of Energy Thermal Efficiency Test.

* Rated in accordance with ARI Standard 270.

† Rated in accordance with ARI Standard 210, 450 cfm (maximum) evaporator air volume per ton of cooling capacity, 95F outdoor air temperature and 80F db/67F wb entering evaporator air.

B - Electrical Data

Model No.		GCS9-411	GCS9-413	GCS9-461	GCS9-463
Line voltage data		1208-230V	208-230V	1208-230V	208-230V
		60hz/1ph	60hz/3ph	60hz/1ph	60hz/3ph
Compressor	Rated load amps	16.8	10.8	20.2	12.8
	Locked rotor amps	75.6	65.0	93.0	74.0
	Power factor	.96	.88	.93	.88
Condenser Fan Motor	Full load amps	1.9	1.9	1.9	1.9
	Locked rotor amps	3.3	3.3	3.3	3.3
Evaporator Blower Motor (230 volt)	Full load amps	4.0	4.0	4.0	4.0
	Locked rotor amps	7.8	7.8	7.8	7.8
Recommended maximum fuse size (amps)		40.0	30.0	60.0	30.0
*Minimum Circuit Ampacity		26.9	19.4	31.2	21.9

Model No.		GCS9-511	GCS9-513	GCS9-651	GCS9-653	
Line voltage data		1208-230V	208-230V	460V	1208-230V	208-230V
		60hz/1ph	60hz/3ph	60hz/3ph	60hz/1ph	60hz/3ph
Compressor	Rated load amps	24.3	15.1	7.4	27.5	16.4
	Locked rotor amps	95.4	78.2	38.7	145.0	120.0
	Power factor	.94	.88	.88	.93	.88
Condenser Fan Motor	Full load amps	1.9	1.9	1.9	1.9	1.9
	Locked rotor amps	3.3	3.3	3.3	3.3	3.3
2 KVA Transformer (FLA)		---	---	4.35	---	---
Evaporator Blower Motor (230 volt)	Full load amps	6.0	6.0	6.0	6.0	6.0
	Locked rotor amps	12.8	12.8	12.8	12.8	12.8
Recommended maximum fuse size (amps)		60.0	40.0	20.0	60.0	40.0
*Minimum Circuit Ampacity		38.3	26.8	17.2	42.3	28.4

* Refer to National Electrical Code manual to determine wire, fuse and disconnect size requirements.

NOTE: Extremes of operating range are plus and minus 10% of line voltage. † Plus 10% and minus 5% of line voltage.

E - RMFG9 With Combination Supply and Return
 Combination ceiling and return applications require the installation of the SRTG9 transitions to the RMFG9 roof mount-

ing frame. The SRTG9 actually consists of both a return transition and a supply transition. Use round duct to connect the transitions to the diffuser.

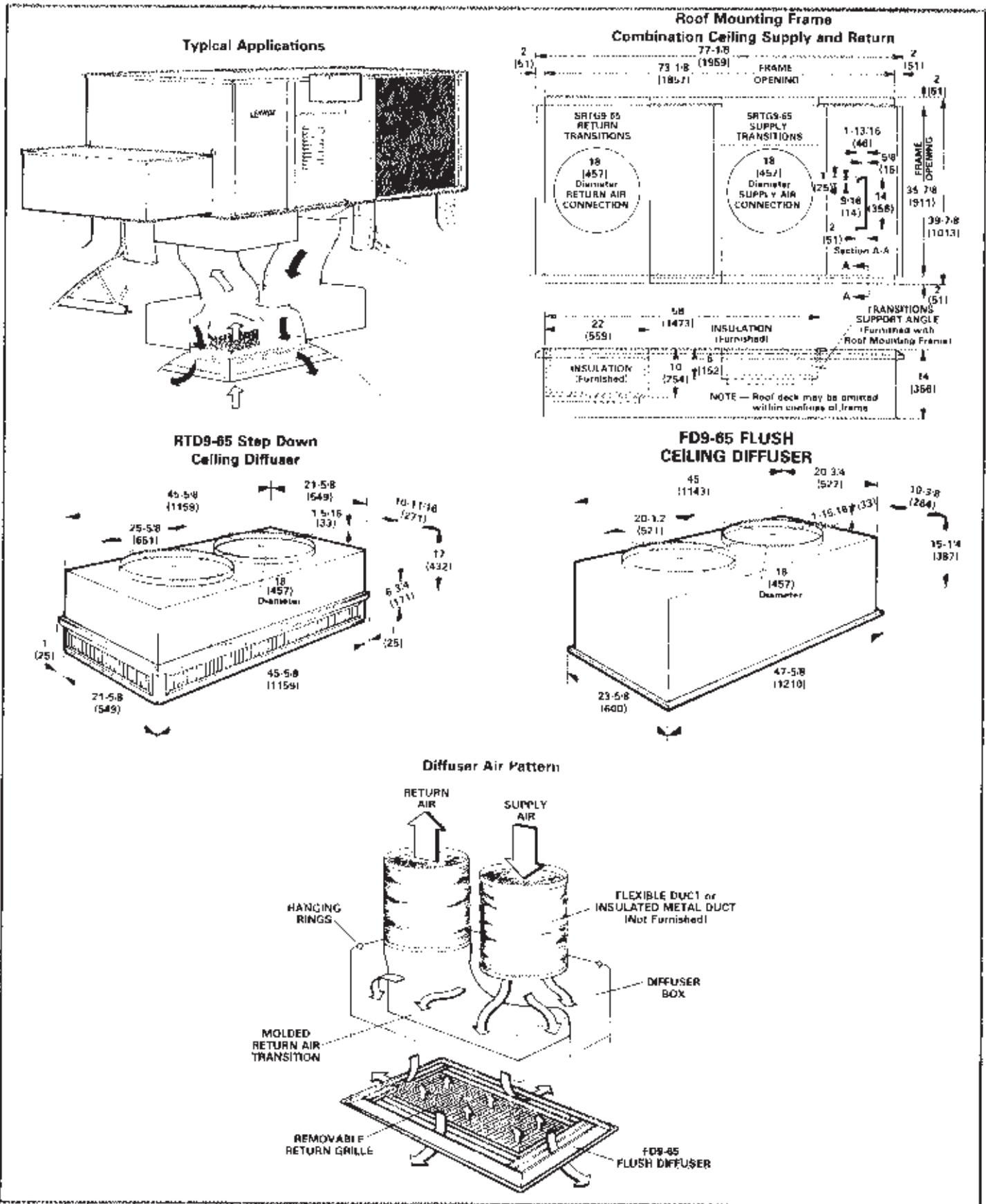

F - Blower Data

GCS9-411-413 BLOWER PERFORMANCE

External Static Pressure (in. wg)	Air Volume (cfm) @Various Speeds		
	High	Medium	Low
0	1960	1725	1610
.05	1910	1700	1585
.10	1865	1660	1550
.15	1815	1620	1515
.20	1760	1575	1475
.25	1710	1535	1440
.30	1660	1485	1395
.40	1545	1390	1300
.50	1425	1285	1200
WITH PSDG9-65 AND DUCT DISTRIBUTION			
0	1860	1640	1530
.05	1815	1615	1505
.10	1770	1575	1470
.15	1725	1540	1440
.20	1670	1495	1400
.25	1625	1460	1370
.30	1575	1410	1325
.40	1470	1320	1235
.50	1355	1220	1140

NOTE — All Cfm is measured external to the unit with the air filter in place.

GCS9-461-463 BLOWER PERFORMANCE

External Static Pressure (in. wg)	Air Volume (cfm) @Various Speeds		
	High	Medium	Low
0	2050	1770	1600
.05	2005	1745	1575
.10	1960	1710	1555
.15	1900	1670	1530
.20	1845	1630	1505
.25	1790	1585	1475
.30	1735	1545	1440
.40	1620	1450	1360
.50	1500	1335	1230
WITH PSDG9-65 AND DUCT DISTRIBUTION			
0	1950	1680	1520
.05	1905	1660	1495
.10	1860	1625	1475
.15	1805	1585	1455
.20	1755	1550	1430
.25	1700	1505	1400
.30	1650	1470	1370
.40	1540	1380	1290
.50	1425	1270	1170

NOTE — All Cfm is measured external to the unit with the air filter in place.

GCS9-651-653 BLOWER PERFORMANCE

External Static Pressure (in. wg)	Air Volume (cfm) @Various Speeds		
	High	Medium	Low
0	2450	1930	1590
.05	2410	1910	1585
.10	2370	1890	1580
.15	2330	1870	1575
.20	2280	1850	1565
.25	2240	1820	1545
.30	2190	1790	1520
.40	2100	1720	1430
.50	2000	1640	1320
WITH PSDG9-65 AND DUCT DISTRIBUTION			
0	2350	1830	1510
.05	2310	1810	1505
.10	2270	1800	1500
.15	2240	1780	1495
.20	2190	1760	1490
.25	2150	1730	1470
.30	2100	1700	1440
.40	2020	1630	1360
.50	1920	1550	1250

NOTE — All Cfm is measured external to the unit with the air filter in place.

GCS9-511-513 BLOWER PERFORMANCE

External Static Pressure (in. wg)	Air Volume (cfm) @Various Speeds		
	High	Medium	Low
0	2345	1865	1560
.05	2305	1850	1555
.10	2270	1830	1550
.15	2230	1810	1545
.20	2185	1790	1535
.25	2145	1760	1515
.30	2095	1730	1490
.40	2010	1665	1400
.50	1915	1585	1295
WITH PSDG9-65 AND DUCT DISTRIBUTION			
0	2250	1770	1480
.05	2210	1750	1475
.10	2175	1740	1470
.15	2145	1720	1465
.20	2095	1700	1460
.25	2060	1675	1440
.30	2010	1645	1410
.40	1935	1575	1335
.50	1835	1500	1225

NOTE — All Cfm is measured external to the unit with the air filter in place.

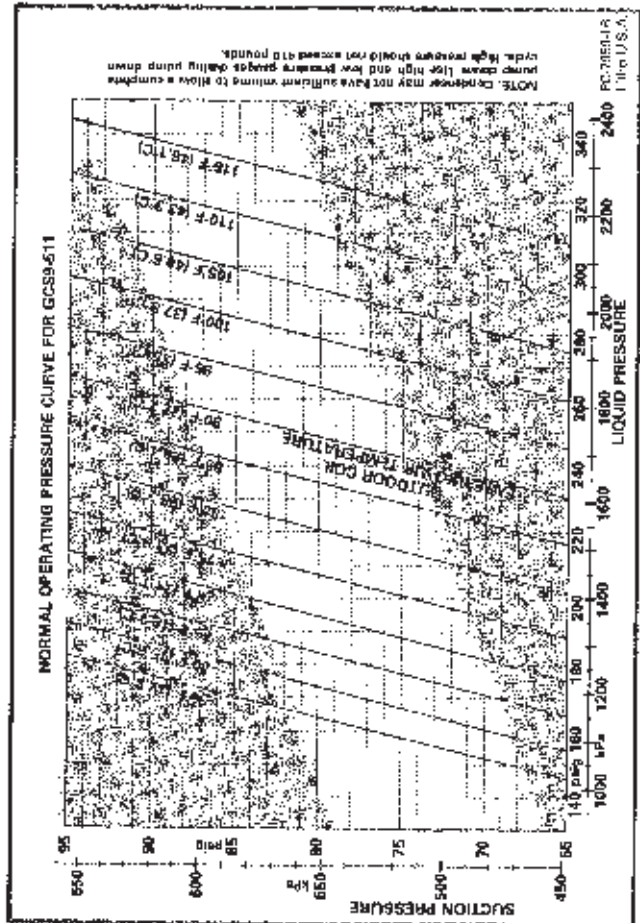
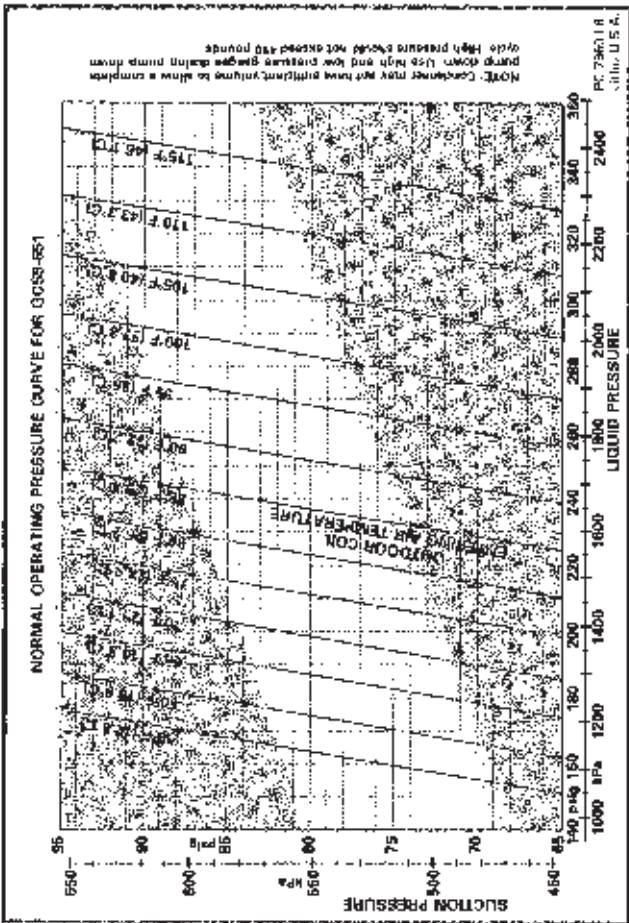
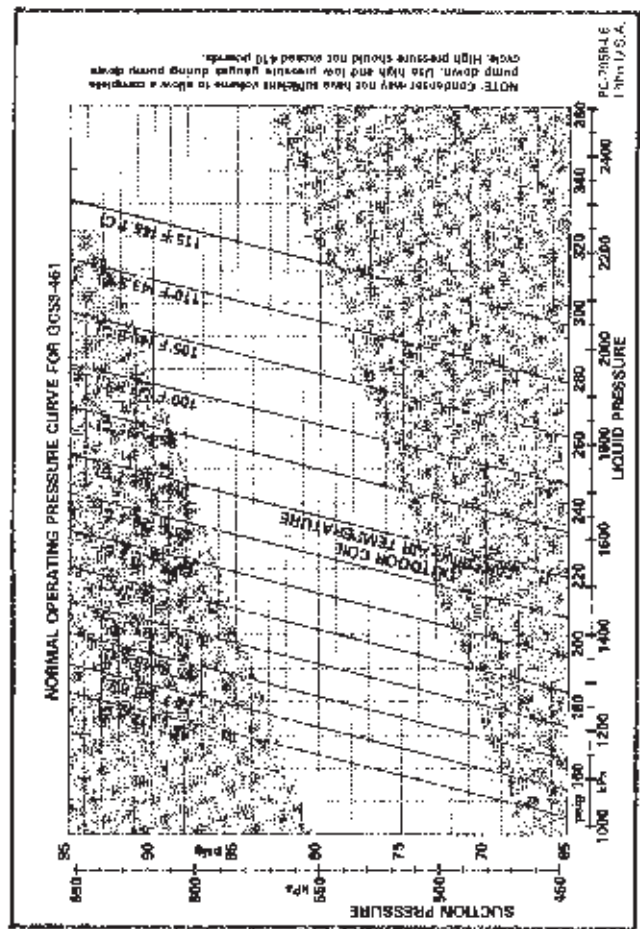
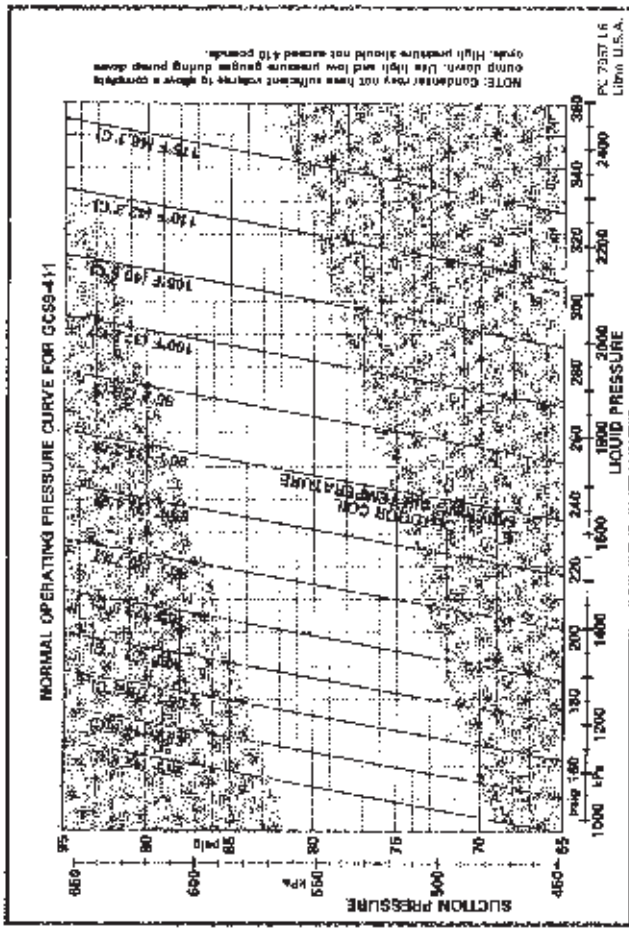

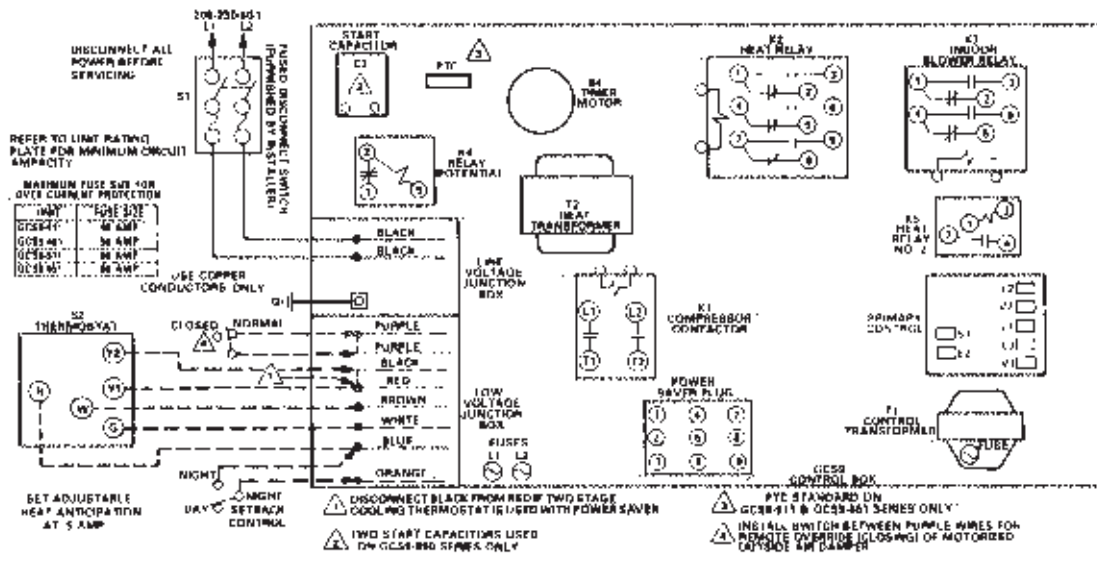

208-230 VOLT SINGLE PHASE UNITS

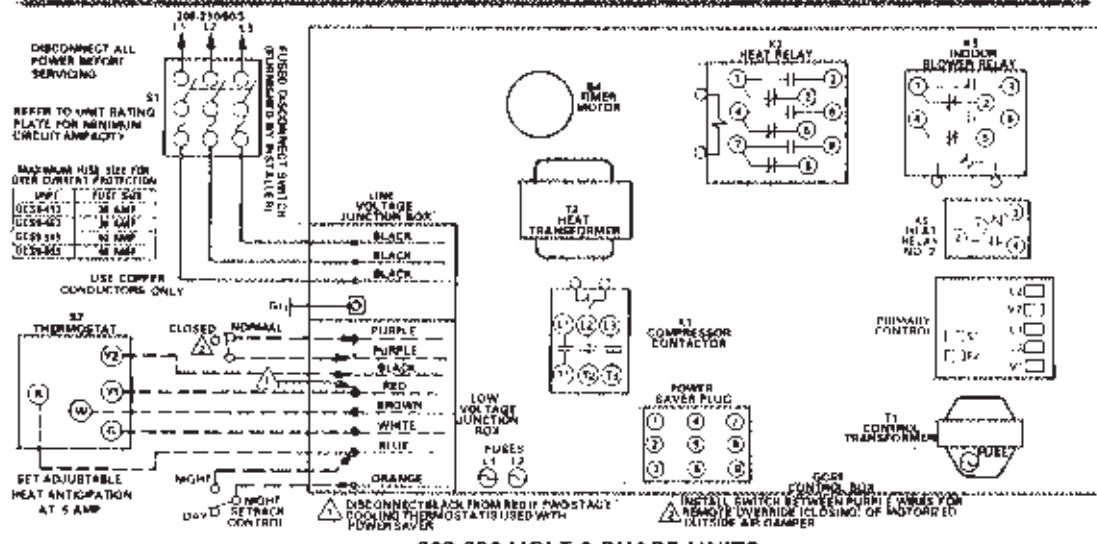

208-230 VOLT 3 PHASE UNITS

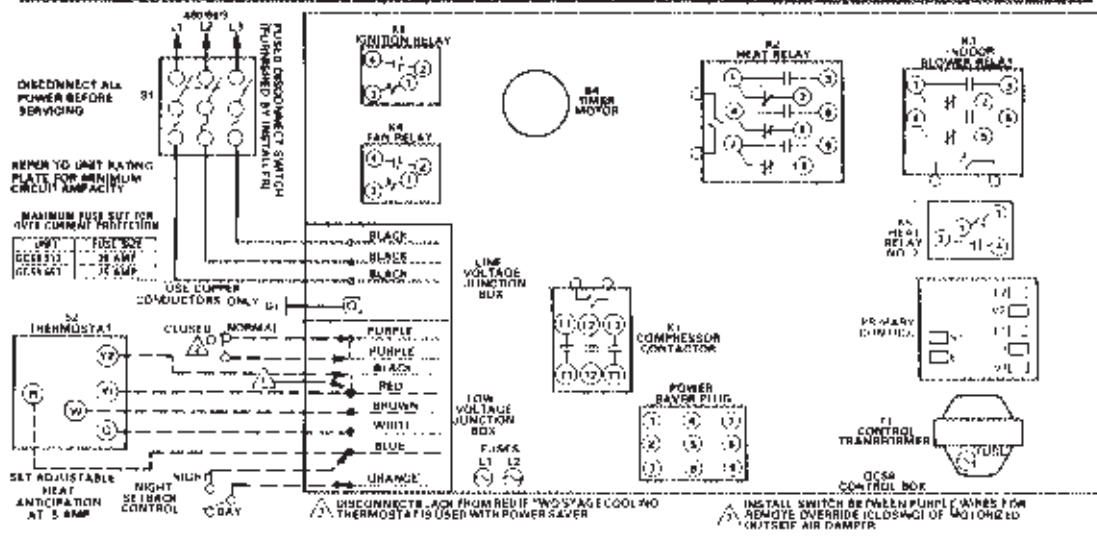

460 VOLT 3 PHASE UNITS

NOTE: IF ANY WIRE IN THIS APPLIANCE IS REPLACED IT MUST BE REPLACED WITH WIRE OF LIKE SIZE RATING AND INSULATION THICKNESS IF RATING AND INSULATION IS UNKNOWN, USE SAME SIZE THERMOPLASTIC 18 C WIRE WITH 46" INSULATION THICKNESS

GCS9 FIELD WIRING

--- LINE VOLTAGE FIELD INSTA-110
 - - - - - LOW VOLTAGE FIELD INSTALLED
 REF. CLASS 2

FIGURE 2

F - PG9 Burner Ratings

BURNER USED	INPUT		OUTPUT	
	BTUH	Kcal/hr	BTUH	Kcal/hr
PG9-120-1	90,000	22700	74,000	78600
PG9-120-1	120,000	30200	95,000	23900
PG9-150-1	120,000	30200	93,000	23400
PG9-150-1	150,000	37800	119,000	30000

G - Field Wiring (Figure 2)

The PSDG9 power saver is available factory or field installed. Power saver connections are made at jack plug located at bottom of unit control box. If a two stage cooling thermostat is used, separate black and red leads at low voltage junction box. The power saver transformer must be wired for correct voltage. See Figure 3.

The OADG9 intake hood is a field option. If a motorized damper is desired, make jack plug connections at low voltage junction box. The transformer must be wired for correct voltage. An overriding switch may be wired through the purple leads to drive dampers completely closed whenever desired.

A night setback control can be wired through the blue and orange leads at low voltage junction box.

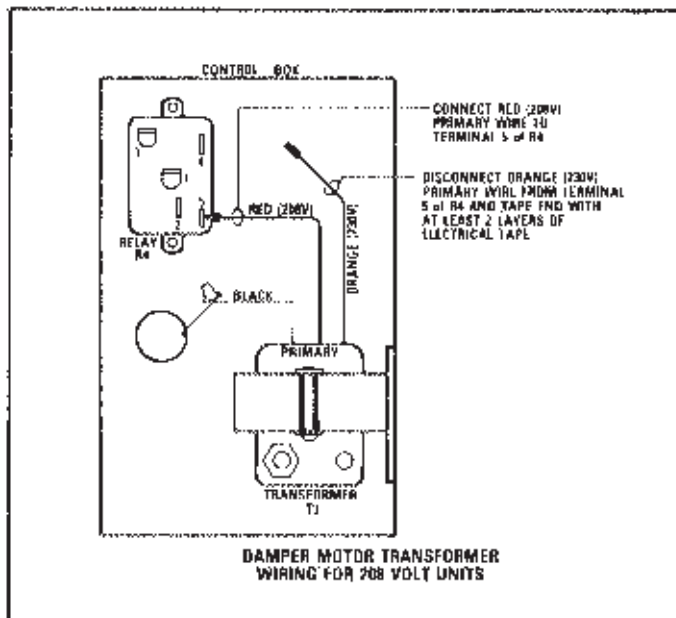

FIGURE 3

III - COMPONENTS

Figure 4 shows an exploded view of a GCSB.

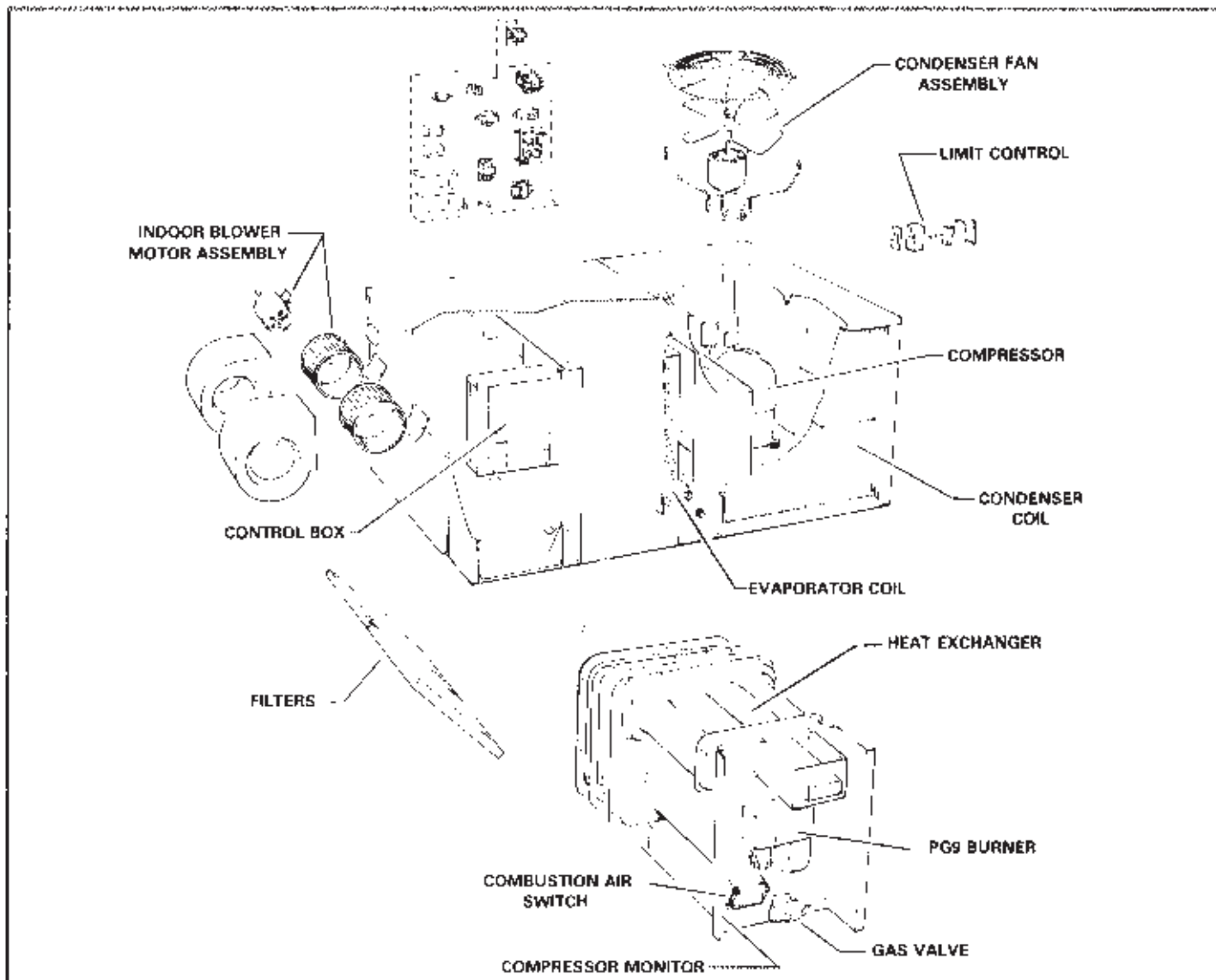

FIGURE 4

A - Control Box

Refer to Field Wiring Diagram for parts arrangement.

- 1 - Compressor Contactor (K1)**
Energizes compressor on a cooling demand. On "P" and "Y" voltage units it also powers condenser fan motor.
- 2 - Heat Relay (K2)**
This relay is energized by "W" leg of thermostat. Initiates blower motor and timer motor (B5) operation. Also energizes heat relay 2 (K5) and ignition relay (K6 - "G" voltage only)
- 3 - Indoor Blower Relay (K3)**
Energizes indoor blower motor.
- 4 - Potential Relay (K4) & Start Capacitor(s) (S2)**
On GCS9-511 and GCS9-651, hard start components may come factory installed in place of the PTC start assist device.
Fan Relay (K4)
On "G" voltage units this relay powers the condenser fan motor. This motor operates on 220V single phase.
- 5 - Heat Relay 2 (K5)**
This relay is energized by K2. It powers the combustion blower motor (B4) and heat transformer (T2 - "P" and "Y" voltage units only).
- 6 - Ignition Relay (K6)**
On "G" voltage units, this relay powers the Primary Control.
- 7 - PTC Start Assist Device**
On GCS9-511 and GCS9-651 units, this solid-state PTC provides extra starting torque to solve most compressor starting problems.
- 8 - 10 Amp Fuses**
Provide protection for control circuits. "P" & "Y" voltage units have two fuses while "G" voltage units have three.
- 9 - Timer Motor (B4)**
This timer keeps the indoor blower motor operating approximately 3 minutes at the end of a heating or cooling cycle.

10 - Primary Control (Figure 5)

The GCS9 uses a Fenwal (style 05-14) direct spark ignition control. The ignition system is solid state, capacitive-discharge and includes an output relay to control the 24V gas valve. Upon a heating call, the control simultaneously energizes the gas valve and generates a spark between the electrodes for the ignition trial period (5-10 seconds). Sparking stops once flame is established. If ignition is not achieved, the control will close valve and lockout. To re-establish trial for ignition, move thermostat switch to "off" for a few seconds and then return to "heat" position.

If the control locks out and can not be reset at thermostat, push the manual reset button at control board. Rapid switching at the thermostat will trip the reset.

An electronic flame sensor monitors flame conditions through flame rectification. In the event of flame outage during a heating cycle, the ignitor will provide one retry for ignition before going into lockout. The flame current range is 2-20 micro-amps.

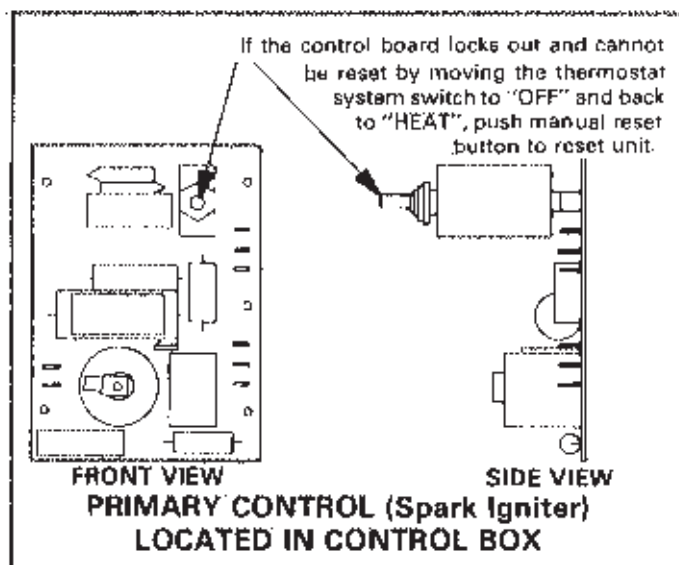

FIGURE 5

- 11 - Control Transformer (T1)**
Provides 24V control circuit. It includes a 2.5 amp fuse.
- 12 - Heat Transfer (T2)**
On "P" and "Y" voltage units this transformer provides 120V to Primary Control.

B - Compressor Compartment

- 1 - Low Pressure Switch (S5)**
This switch is located in the suction line. It cuts out at 25 psig \pm 5 and automatically resets at 55 psig \pm 5.
- 2 - Compressor**
Compressor has internal overload protection and a pressure relief valve. The relief valve opens at a discharge and suction differential of 450 psig \pm 50. Compressors have crankcase heaters which are energized continuously.

C - Heating Section

- 1 - Compressor Monitor (S10)**
The manually adjustable compressor monitor locks out compressor operation at outdoor temperatures below the monitor setting. Factory setting for units without optional power saver is 35°F. Refer to Power Saver settings to adjust compressor monitor if Power Saver option is added.
- 2 - Combustion Air Switch (S4)**
This switch proves blower operation before allowing an ignition trial. The switch is factory set and no field adjustment is necessary.
- 3 - Gas Valve**
The GCS9 uses a redundant main gas valve. This valve incorporates two internal solenoids which are both energized on a heating demand. Should one solenoid stick open, the other assures gas shut off.
- 4 - PG9 Power Burner (Figure 6)**
The PG9 burner comes in two basic sizes. Each of these sizes is further rated at a minimum and maximum Btuh input. The PG9-90/120 burner has a single venturi and installs in GCS9-410 and GCS9-460 models. The PG9-120/150 burner has two venturis and installs in GCS9-510 and GCS9-650 models.

The 1/20 H.P. blower motor provides air for combustion. It prepurges heat exchanger (through combustion air switch proving) before ignition trial period. The venturi mixes air and gas in correct proportion for proper combustion. The fuel mixture is ignited by sparking at the electrodes which is initiated by the primary control. The flame spreader fits flame to combustion chamber for uniform heat distribution. An electronic flame sensor system monitors flame condition. In the event of flame out age, the primary control locks out the gas valve.

The burner has an inspection window to view flame.

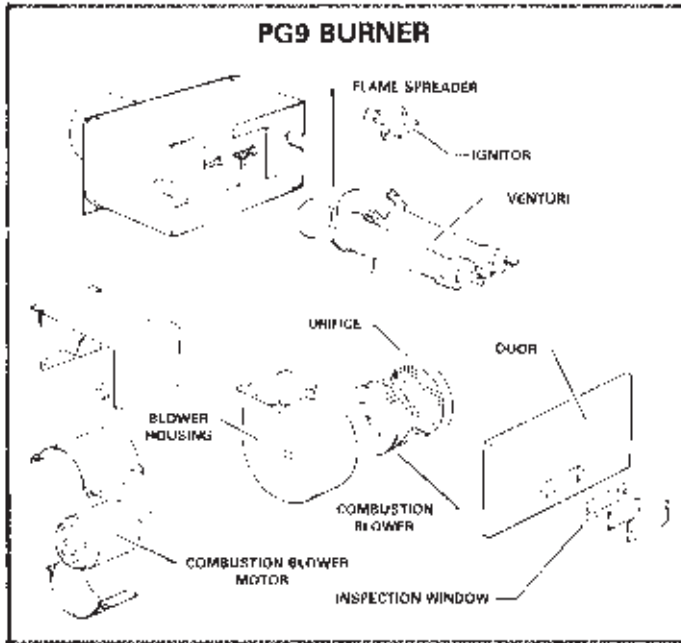

FIGURE 6

5 - Limit (S3) & Auxiliary Limit

At excessive unit temperatures these controls de-energize the 24V circuit to primary control and heat relay. The gas valve is also de-energized at primary control.

D - Condenser Coil

Air draws through the coil and is discharged out the top of unit. The ball bearing condenser fan motor is permanently lubricated, and has thermal cutout protection. For fan motor service access, remove the bolts securing fan motor assembly. Figure 7 illustrates the condenser fan and motor assembly.

IV - REFRIGERANT SYSTEM

GCS9 units have a single compressor in a single refrigeration system. The expansion valve used changes super heat setting in response to the affects of low ambient conditions on the outdoor coil. The suction and discharge line service ports are located in compressor compartment. See Figure 8. The head pressure given on operating curves is based on discharge pressure.

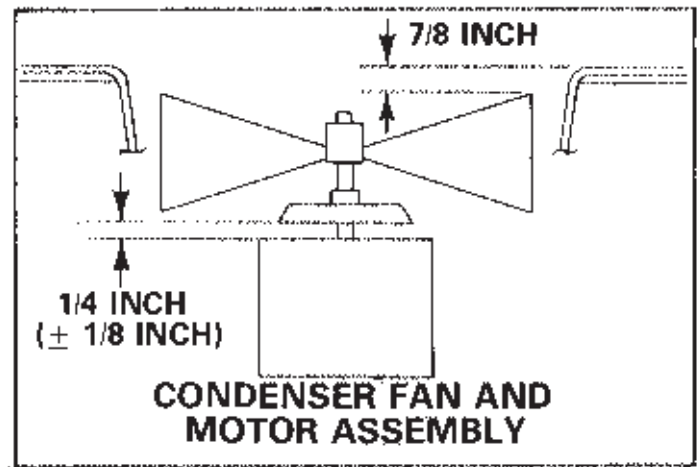

FIGURE 7

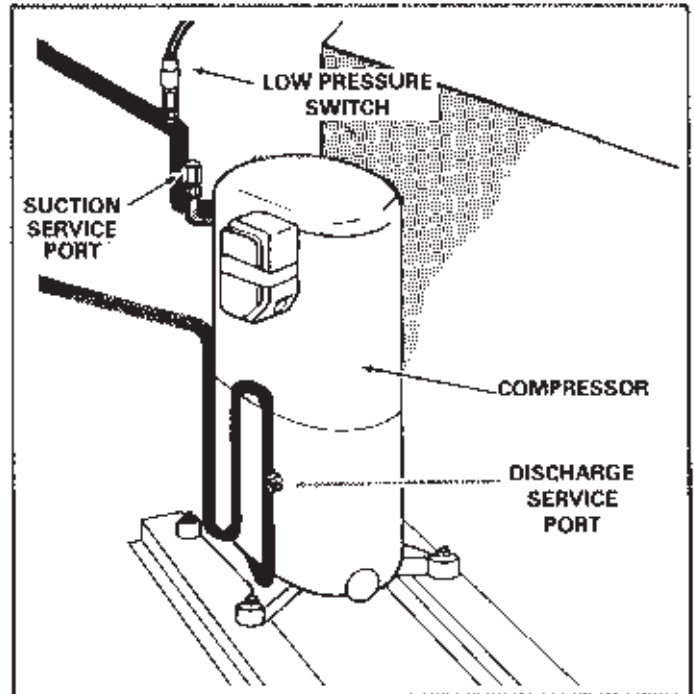

FIGURE 8

V - POWER SAVER OPTION

During power saver operation the outdoor air dampers open and the return air dampers close. Refer to Figure 9. Outdoor air provides first stage cooling when the thermostat requires cooling. Figure 10 shows the PSDG9 control box. Controls affecting power saver operation include:

1 - Power Saver Relay (K7)

This relay initiates power saver operation with a first stage cooling demand.

2 - Enthalpy Control (at outdoor air hood)

The recommended set point is "A". If power saver allows air which is too warm or too humid to enter system, control may be adjusted to a lower set point. Refer to Chart A.

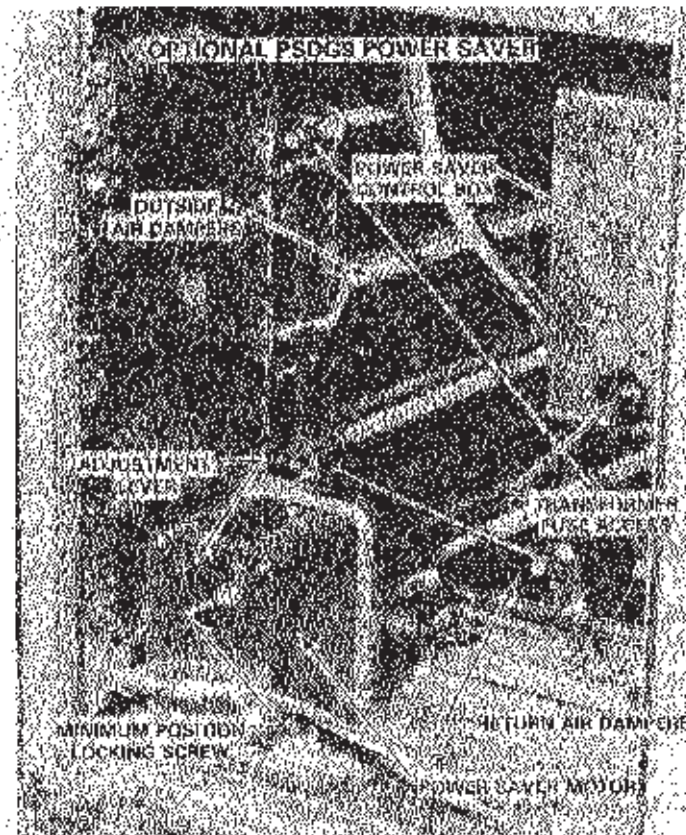

FIGURE 9

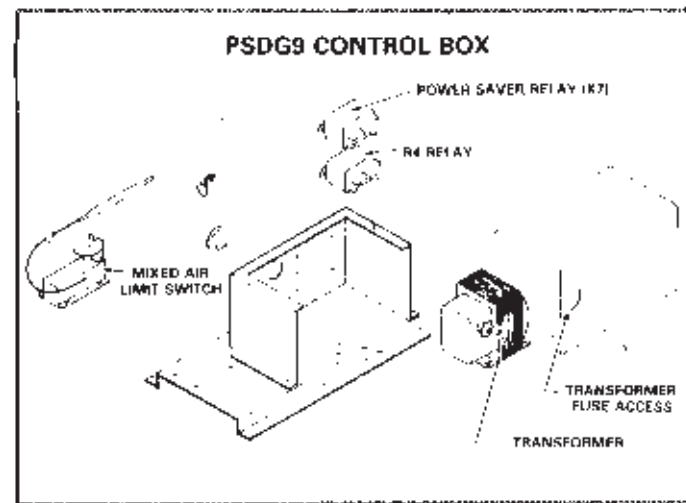
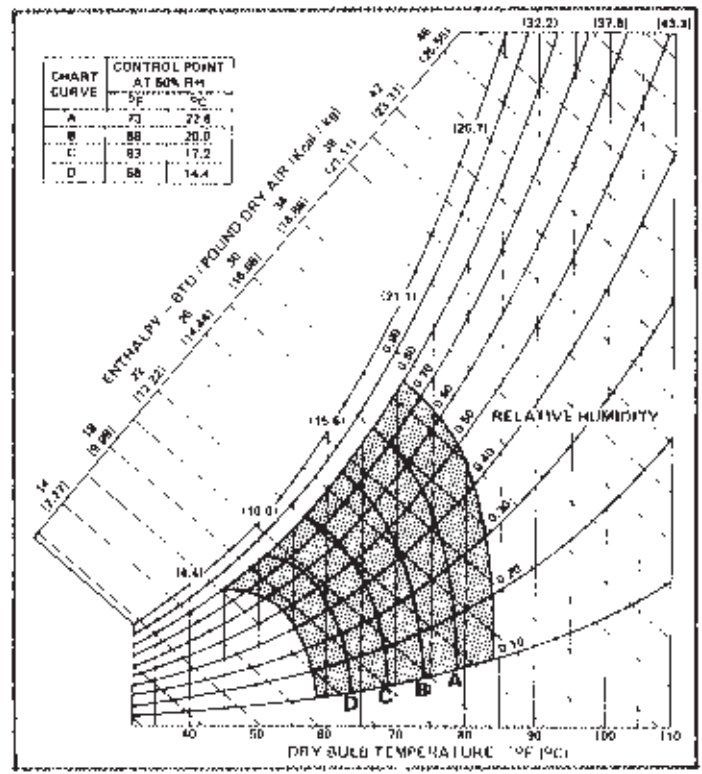

FIGURE 10

- 3 - Mixed Air Limit Switch (in power saver control box)**
The recommended setting is 55°F. The mixed air limit senses the temperature in the unit return air section. Outdoor air blades will close to minimum position when temperature drops below the limit setting.
- 4 - Compressor Monitor Limit Switch (control adjustment in burner compartment)**
The recommended setting is 58°F when power saver is used. At outdoor temperatures below the limit setpoint, the compressors (mechanical cooling) are locked out. If power saver is field installed be sure to reset the limit setpoint from its factory setting of 35°F.

CHART A



- 5 - Minimum Positioner (at damper blades)**
Using steps "a" through "f" listed below, set blades in minimum position.
 - a - Check to make sure all wiring is connected properly.
 - b - Set thermostat switch to "OFF" and fan switch to "ON". Turn on power to unit to power damper motor.
 - c - Refer to Table 2 for desired minimum blade setting.
 - d - Loosen screw on damper motor.
 - e - Set blades, by adjusting lever to desired position.
 - f - Tighten screw on damper motor.

IMPORTANT - After adjustment is completed, return enthalpy control to desired setting.

TABLE 2

Damper Blade Angle	FRESH AIR PERCENTAGE (%)		
	Return Air Duct Static Pressure		
	0" (0mm)	.25" (6mm)	.5" (13mm)
5°	13	20	30
10°	26	34	46
15°	37	46	57
20°	48	57	66
25°	58	66	74
30°	69	75	81
35°	79	84	88
40°	90	92	94

VI - OUTDOOR AIR HOOD OPTION

- Units with optional OADG9 intake hood may contain motor driven or manually set fresh air dampers. Refer to Table 2 for dimensional blade opening and resulting fresh air percentage.
- 1. Set damper blades in open position.

- 2 - Motor driven blades will open to the set minimum position when blower is on. To set blades to desired minimum position, use steps "a" through "f" listed below.
 - a - Check to make sure all wiring is connected properly.
 - b - Set thermostat switch to "OFF" and fan switch to "ON". Turn power on to unit to power damper motor.
 - c - Refer to Table 2 for desired minimum blade setting.
 - d - Loosen screw on damper motor.
 - e - Set blades, by adjusting lever, to desired position.
 - f - Tighten screw on damper motor.
- 3 - An override switch may be installed to close damper when desired. See Field Wiring section.

VII - HEATING SYSTEM

GCS9 input and output ratings are listed on page 5.

A - Gas Pressure Adjustment

- 1 - Check gas line pressure with unit fired. A minimum of 6" w.c. should be maintained. On multiple unit installations, each unit should be checked in sequence, beginning with the one closest to the supply gas main and progressing to the one furthest from main.
- 2 - After line pressure has been checked and adjusted, check manifold pressure. Refer to Figure 11 for location to take reading. Manifold pressure should be 4.0" w.c.

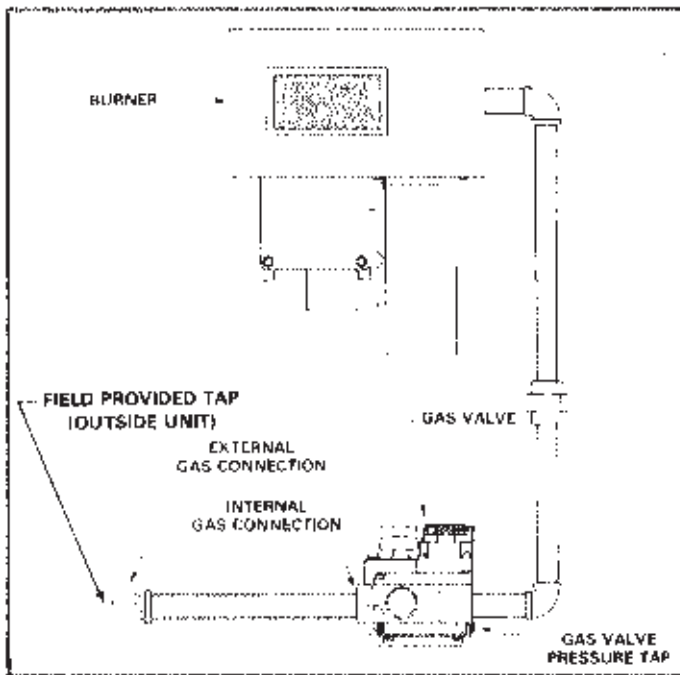

FIGURE 11

B - High Altitude Derate

If the heating value of the gas does not exceed values listed in Table 3, derating of the unit is not required. Should the heating value of the gas exceed the table values, or if the elevation is greater than 6,000 feet above sea level it will be necessary to derate the unit. Lennox requires that derate conditions be 4% per thousand feet above sea level. Thus at an altitude of 4000 feet, if the heating value of the gas exceeds 1000 Btu/ft³, unit will require a 16% derate.

TABLE 3

Elevation Above Sea Level (Feet)	Maximum Heating Value (Btu/ft ³)
5001 — 6000	900
4001 — 5000	950
3001 — 4000	1000
2001 — 3000	1050
Sea Level — 2000	1100

C - Combustion Air Adjustment

The combustion air is factory set for normal operation. Minor adjustments for flame lifting, burner noise, and etc., will be necessary. Refer to Figure 12. Figure 13 depicts proper burner flame.

The flame appearance will be basically blue, but there will be clear yellow streaking in the flame. It will not be all blue.

The combustion air adjustment on each PG9 burner has a minimum set point as determined by stop nuts. Dimension "A" in Figure 14 reflects each burners setting.

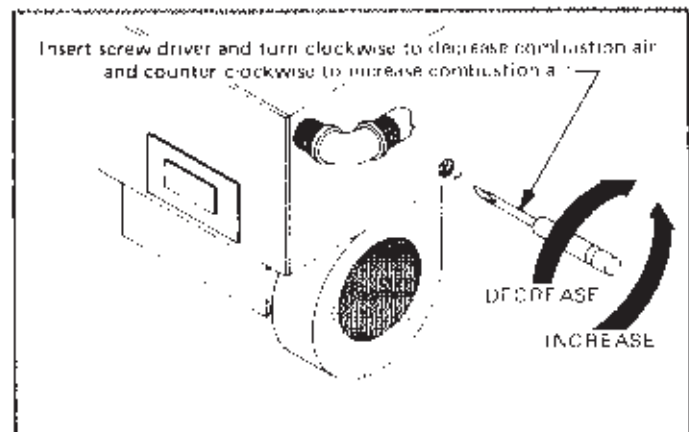

FIGURE 12

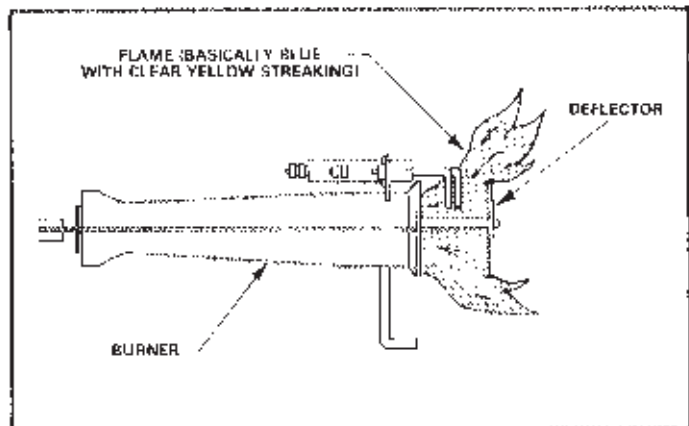

FIGURE 13

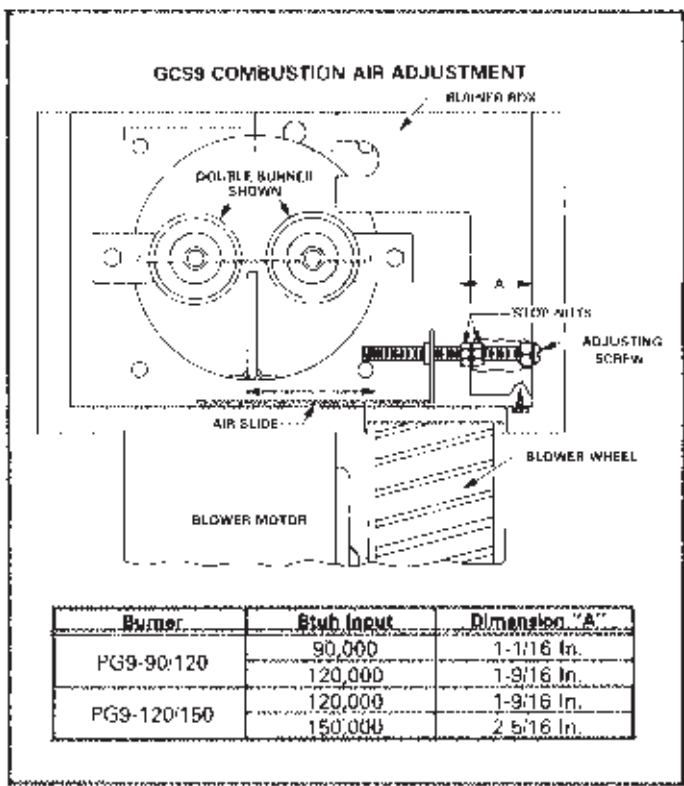

FIGURE 14

D - Electrode Setting

The correct electrode gap must be maintained for proper operation. See Figure 15.

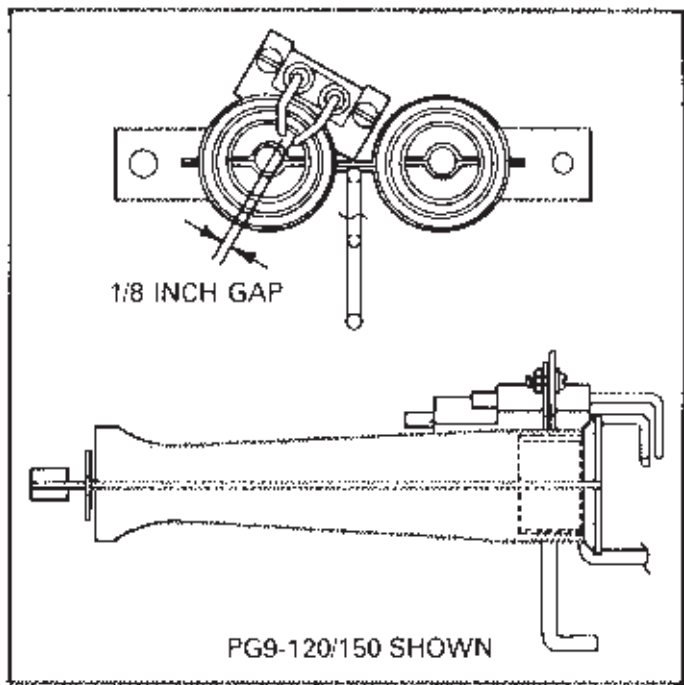

FIGURE 15

E - Cleaning Combustion Air Blower

To insure efficient operation the combustion air blower must be kept clean.

- 1 Shut off power to unit.
- 2 - Remove (2) screws securing combustion air blower motor assembly. See Figure 16.
- 5 - Slide combustion air blower housing and motor assembly

- 6 - Remove screen covering blower wheel.
- 7 - Using a small brush clean blower blades. See Figure 17. **IMPORTANT** - If blower wheel must be removed, loosen allen screw and pull wheel out of housing. When replacing wheel make sure flat on motor shaft lines up with flat on blower wheel, and that allen screw is tightened securely.

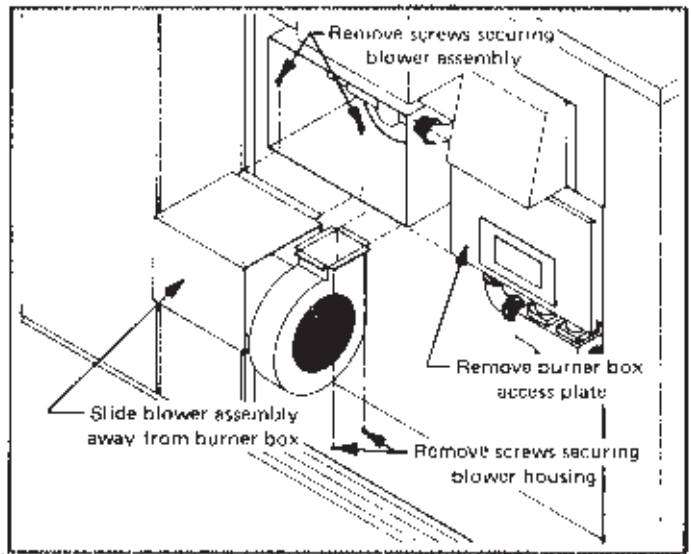

FIGURE 16

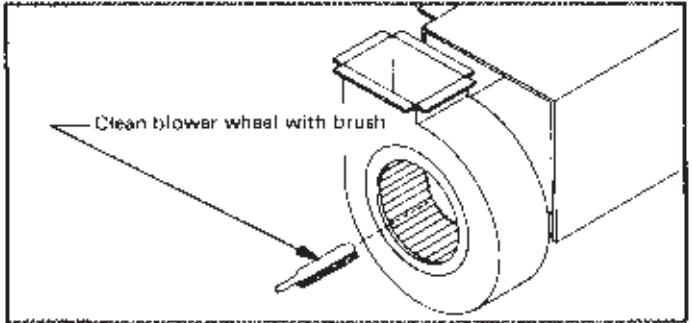

FIGURE 17

F - Checking Vent Cap

The vent cap should be inspected at the beginning of the heating season and monthly thereafter. Look for signs of sooting, corrosion and any obstruction such as leaves, bird nest, insect nest or other material. Remove any obstruction. Table 4 lists a maintenance frequency chart.

TABLE 4

MAINTENANCE FREQUENCY CHART	
Item	Time Schedule
Check & Clean Blower Wheel	Annually
Lubricate Blower Motor	Annually (if Necessary)
Clean Filters	Monthly
Clean Combustion Air Blower	Annually
Inspect Flue Passages	Annually
Check Burner Flame	Periodically
Check Vent Cap	Monthly (During Heating Season)

F - Inspecting Flue Passages

If it should be necessary to clean the flue gas passageways, use the following steps.

- 1 - Remove the rear cabinet panel. To do this remove sheet metal screws holding the panel in place and the corner

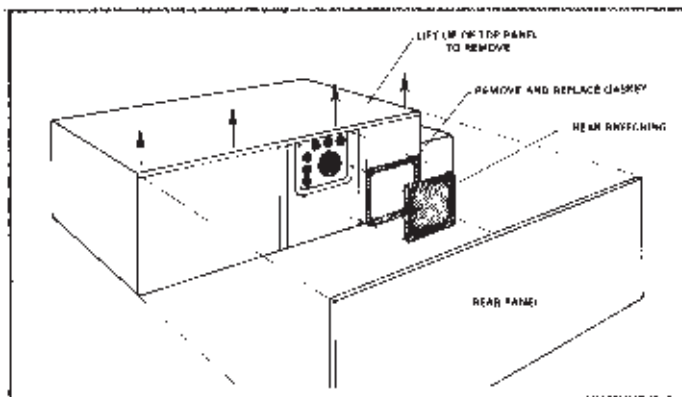

FIGURE 18

screws holding the top panel at the mullions. Lift top panel to clear the rear panel and remove rear panel.

- 2 - Unscrew the cap screws and remove the rear breaching of the heat exchanger.
- 3 - Slide the flue restrictors from the heat exchanger tubes.
- 4 - Clean the flue gas passageways, using a wire brush.
- 5 - Re-assemble the unit. It is recommended that the rear breaching gasket be replaced when re-assembling the heat exchanger. Refer to Figure 18.

VIII - BLOWER SPEED ADJUSTMENT

GCS9 units are equipped with direct drive blowers. Table 5 shows the speed selection chart for these units.

A - Temperature Rise

Adjust blower speed for proper air temperature rise listed on unit nameplate. To measure this temperature rise, place plenum thermometers in warm air and return air plenums. Turn thermostat high as possible to start unit. After plenum thermometers have reached their highest and steadiest readings, subtract the readings. The difference should be within range listed on unit rating plate. If this temperature is low, decrease blower speed; if temperature is high, increase blower speed. Refer to unit wiring diagram to wire blower motor to higher or lower speeds.

TABLE 5

BLOWER SPEED SELECTION	
SPEED	RIFINER AND/OR LEAD
LOW	RED
MEDIUM LOW	...
MEDIUM	YELLOW
MEDIUM HI	...
HIGH	BLACK

B - Checking Evaporator Coil Air Pressure Drop

- 1 - The air test hole on the air inlet side of the coil is located in the burner compartment vestibule panel. See Figure 19. The air test hole on the outlet side of the coil is located in evaporator mullion.
- 2 - Remove the snaphold plugs and insert an awl or screwdriver to open up the insulation behind the holes.
- 3 - Insert the hoses from the draft gauge into the air test holes so about 1/4" extends inside cabinet. Seal around the holes with Permaquim. Connect zero end of draft gauge to the air entering side of coil.
- 4 - To start evaporator blower motor, move thermostat heat selector to the lowest setting. Place the system switch in the "COOL" or "AUTO" position and the fan switch in the

"CONT." position. Turn on the power supply. Evaporator blowers only will operate.

- 5 - Table 6 lists a range of air volumes and equivalent draft gauge readings for this unit. Observe draft gauge readings with evaporator blowers running. If reading is below air volume required, increase blower speed. If reading is above air volume required, decrease blower speed. Refer to unit diagram.
- 6 - After required draft gauge reading is obtained, remove draft gauge lines and replace snaphold plugs. Turn off blower motors.

TABLE 6

UNIT	DRAFT GAUGE READINGS (DRY EVAPORATOR)			
	AIR VOLUME		READING	
	CFM	m ³ /hr	in. w.c.	mm. w.c.
GCS9-411	1100	1870	090	2.29
	1200	2040	105	2.67
	1300	2210	120	3.05
	1400	2380	135	3.43
	1500	2550	150	3.81
	1600	2720	165	4.19
GCS9-461	1200	2040	077	1.96
	1300	2210	086	2.18
	1400	2380	095	2.41
	1500	2550	104	2.64
	1600	2720	116	2.95
	1700	2890	128	3.25
GCS9-511	1500	2550	078	1.98
	1600	2720	088	2.24
	1700	2890	098	2.49
	1800	3060	108	2.74
	1900	3230	118	3.00
	2000	3400	128	3.51
GCS9-65*	1800	3060	053	1.35
	1900	3230	058	1.47
	2000	3400	062	1.57
	2100	3570	066	1.68
	2200	3740	071	1.80
	2300	3910	077	1.96
	2400	4080	083	2.11

NOTE These are pressure drops across the coil.

*Coil tap probe must extend into coil compartment 12 3/4"

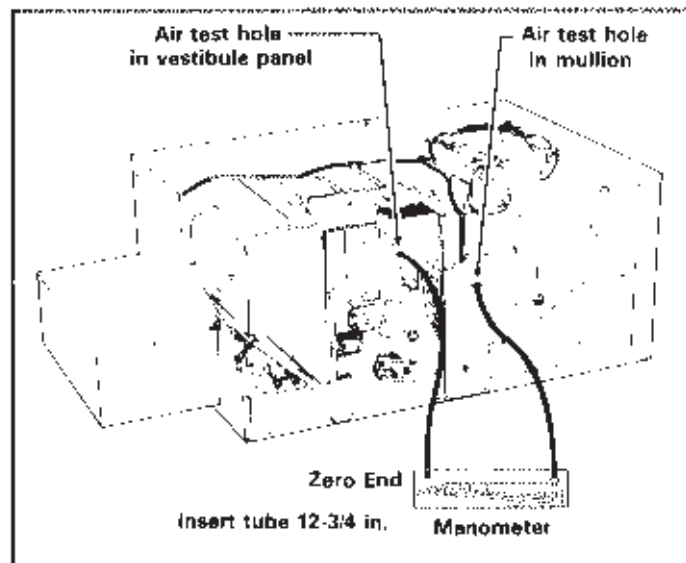
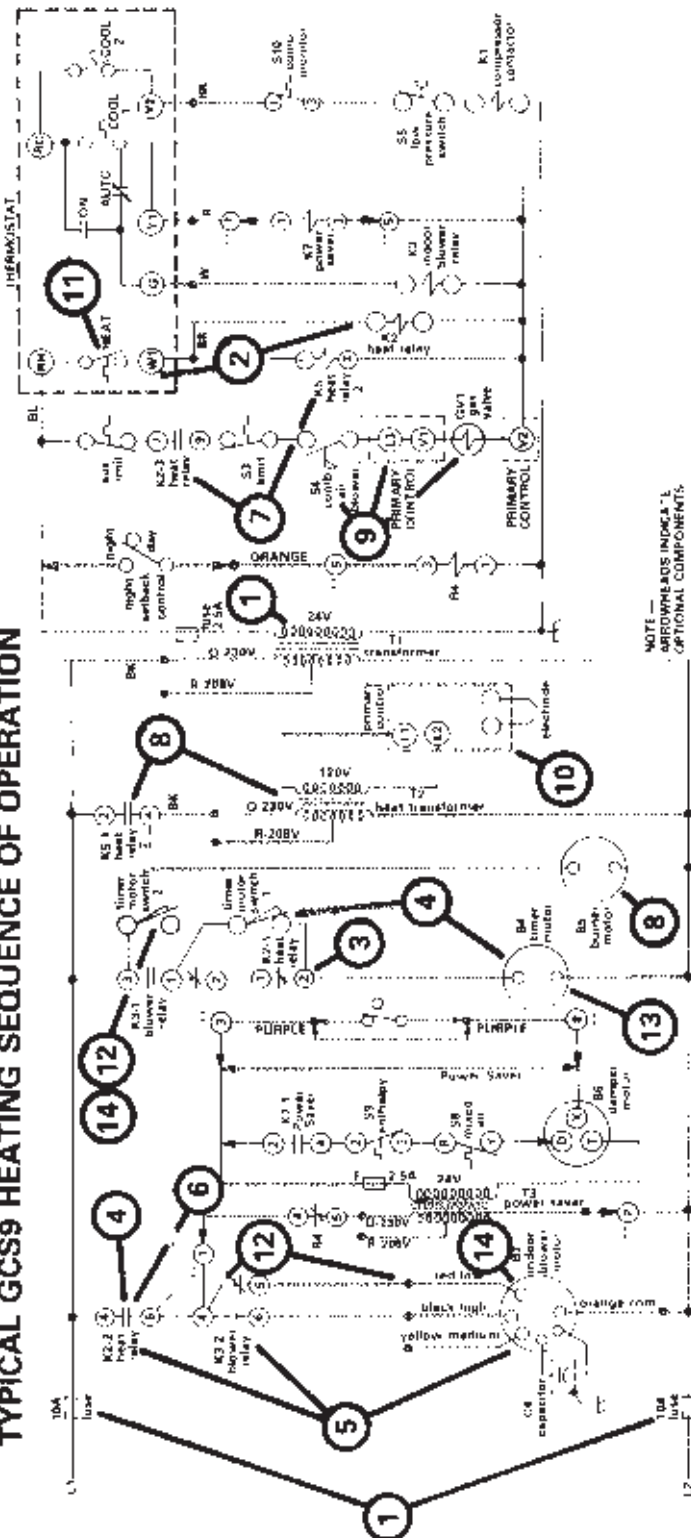

FIGURE 19

IX - SCHEMATIC WIRING DIAGRAM OPERATING SEQUENCE

Figure 20 illustrates the heating sequence of operation for a typical GCS9 while Figure 21 explains cooling operation.

TYPICAL GCS9 HEATING SEQUENCE OF OPERATION



NOTE -
ARROWHEADS INDICATE
OPTIONAL COMPONENTS.

- 1 - The control circuits are protected by 10 amp fuses. The control transformer (T1) provides the 24 volt thermostat circuit.
- 2 - On a heating demand the thermostat heating bulb makes to energize Heat Relay (K2).
- 3 - N.C. K2-1 contacts open. During the heating cycle Timer Motor (B4) can only be run through its number 1 switch.
- 4 - N.O. K2-2 contacts close. This completes a circuit to B4 through switch 1. B4 rotates 24 before switch 1 breaks to stop motor. Switch 2 makes at 13.
- 5 - As K2-2 contacts make, the Indoor Blower Motor (B3) is powered on low speed through N.C. K3-2 contacts.
- 6 - If the installation includes power saver or motorized damper options, K2-2 also completes a circuit to Power Saver Transformer (T3) through R4 relay. The outside dampers are held at minimum position.
- 7 - N.O. K2-3 contacts also make. This completes a circuit to Heat Relay 2 (K5) coil through the Auxiliary Limit and Limit (LS).
- 8 - N.O. K5-1 contacts close to power Combustion Blower Motor (B5) and Heat Transformer (T2). T2 provides a 120V circuit to Primary Control. The Primary Control starts sparking.
- 9 - With B5 running the Combustion Air Blower Switch (S4) makes. This completes a circuit through the Primary Control to energize the gas valve.
- 10 - With sparking and gas flow, ignition should take place. If ignition is not achieved during the trial period (5 - 10 seconds), the Primary Control will lockout. Should there be flame-out during an "on" cycle, the Primary Control will again lockout.
- 11 - As the demand is satisfied, the heating bulb opens. This de-energizes K2, K5, B5, T2, Primary Control and Gas Valve.
- 12 - The Indoor Blower Motor continues running through switch 2 and N.C. K3-2 contacts.
- 13 - With N.C. K2-1 contacts again closed, Timer Motor (B4) is powered through switch 2. B4 revolves from 24 to 360 before switch 2 breaks to stop motor. It takes approximately 3 minutes to travel the distance. Switch 1 makes at 349 in preparation for next cycle.
- 14 - With switch 2 open the Indoor Blower Motor and T3 are de-energized. Damper blades return to the closed position.

STEP 4
DETAIL

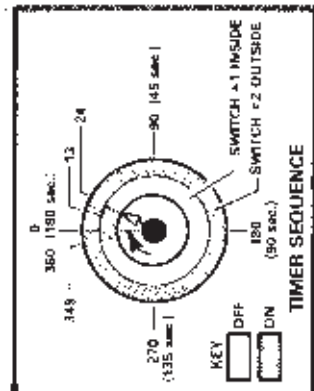

STEP 13
DETAIL

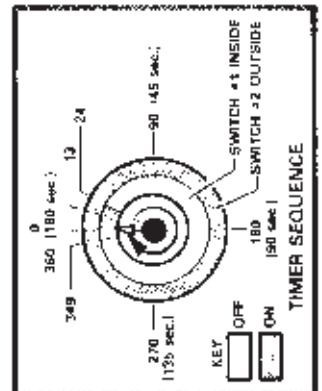
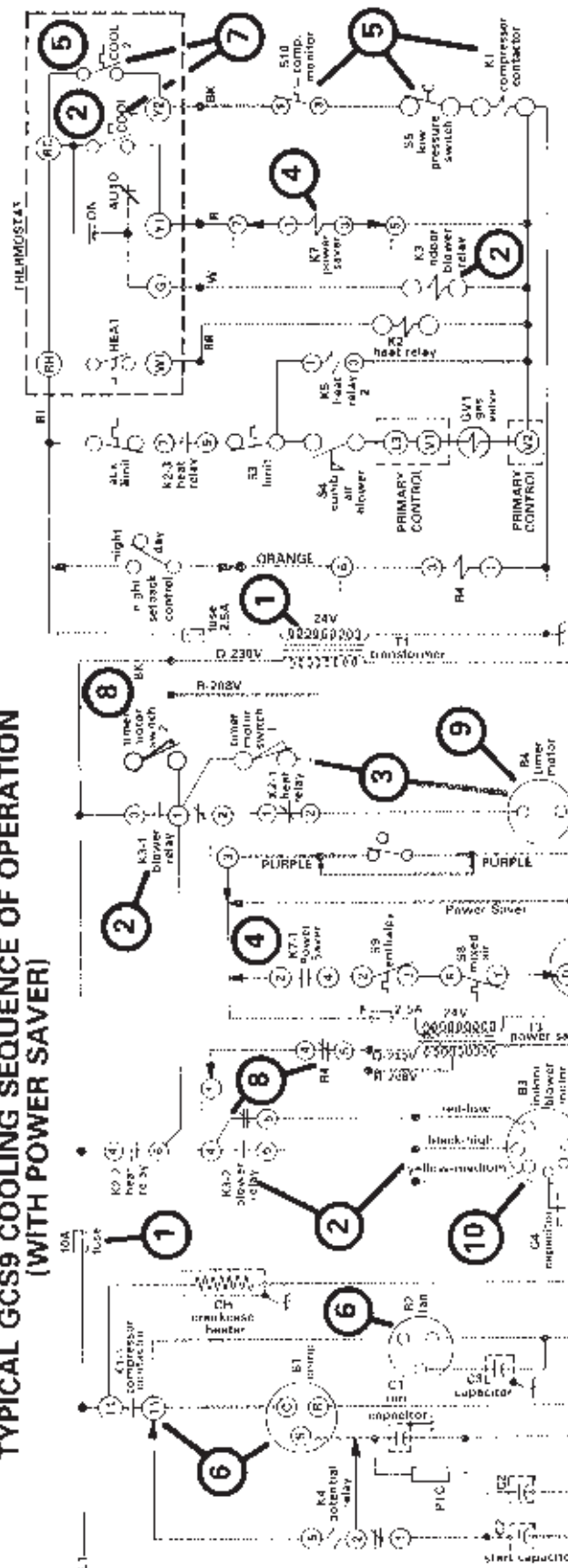

FIGURE 20

TYPICAL GCS9 COOLING SEQUENCE OF OPERATION (WITH POWER SAVER)



••• DENOTES POWER SAVER PLUG

NOTE - ARROWHEADS INDICATE OPTIONAL COMPONENTS

- 1 - The control circuits are protected by 10 amp fuses. The control transformer (T1) provides the 24 volt thermostat circuit.
- 2 - On a cooling demand the first stage cooling makes. If the thermostat fan switch is set on "Auto", the indoor blower relay (K3) is energized. N.O. K3-1 and N.O. K3-2 contacts close to energize the indoor blower motor on high speed. And also to energize the power saver relay (T3).
- 3 - As N.O. K3 1 makes it also powers the timer motor (B4) through switch 1. B4 rotates 24° before switch 1 breaks to stop motor. Switch 2 makes at 13°, but cannot power B4 since N.C. K3-1 contacts are now open.
- 4 - As the first stage cooling bulb makes, it also energizes the power saver relay (K7). N.O. K7-1 contacts make to energize the power saver damper motor (B6) providing the enthalpy control (S9) and mixed air control (S8) are made. Should S8 or S9 open the damper motor goes to minimum position.
- 5 - On a further cooling demand the second stage cooling bulb makes. This energizes the compressor contactor (K1) providing that the compressor monitor (S10) and low pressure switch contacts are made.
- 6 - N.O. K1-1 contacts make to power the compressor and the condenser fan motor. On "G" voltage an addition fan relay is used to activate condenser fan motor.
- 7 - As the cooling demand is satisfied the cooling thermostat bulbs close in reverse order. This de-energizes K1, compressor, condenser fan motor, K7 and K3.
- 8 - The indoor blower motor continues running through switch 2 and N.C. K3-2 contacts. Damper motor will drive to minimum position.
- 9 - With N.C. K3-1 contacts again closed, timer motor (B4) is powered through switch 2 and N.C. K2-1. B4 revolves from 24° to 360° before switch breaks to stop motor. It takes approximately 3 minutes to travel the distance. Switch 1 makes at 349° in preparation for next cycle.
- 10 - With switch 2 open the Indoor Blower Motor and T3 are de-energized. Damper blades return to the closed position.

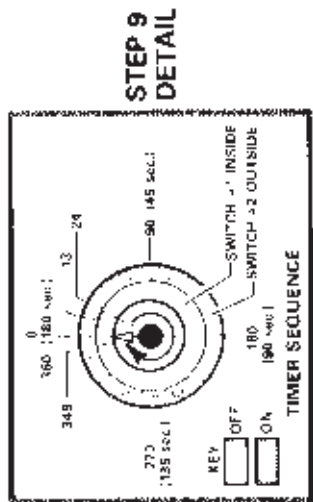
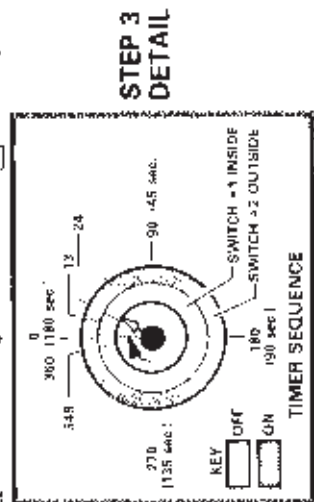

FIGURE 21
Page 16