

11. CEILING SUSPENSION TYPE PACKAGED AIR-CONDITIONER

**(Split system, Air cooled)
cooling only type**

Alternative refrigerant R407C use models

FDENP208CEN-S

258CEN-S

308CEN-S

308CES-S

408CES-S

508CES-S

CONTENTS

11.1 GENERAL INFORMATION	443
11.1.1 Specific features	443
11.1.2 How to read the model name	443
11.2 SELECTION DATA.....	444
11.2.1 Specifications	444
11.2.2 Range of usage & limitations	450
11.2.3 Exterior dimensions	451
11.2.4 Exterior appearance	457
11.2.5 Piping system	458
11.2.6 Selection chart	460
11.2.7 Noise level	462
11.3 ELECTRICAL DATA.....	463
11.3.1 Electrical wiring	463
11.4 OUTLINE OF OPERATION CONTROL BY MICROCOMPUTER	467
11.5 APPLICATION DATA	467
11.6 MAINTENANCE DATA.....	467

11.1 GENERAL INFORMATION

11.1.1 Specific features

- (1) Less refrigerant charge amount due to use of double phase refrigerant flow system. The total refrigerant charge amount has been reduced by more than 50%.
- (2) The indoor outdoor interconnection signal wiring has been done away with. The microcomputer chip is installed in the indoor unit. There is no need for the unit to communicate between the outdoor and indoor units so the unit is more resistant to electromagnetic noise thus the incidence of microcomputer malfunction has been reduced. The compressor in the outdoor unit has its own self protection function, that reacts according to abnormal high pressure and excessive high temperature.
- (3) There are only four power lines between the outdoor and indoor unit. As no signal wire is used there is no need to separate the power line from the signal line. One cable with 4 wires encased in one sheath is enough for conducting the wiring work between the outdoor unit and the indoor unit. This contributes to simpler wiring work in the field.
- (4) The operation modes are only cooling and fan operation for easier control.
- (5) All air supply ports have auto swing louvers. The indoor fan motor has two speeds of high and low.
- (6) The controls are wireless residential split air conditioner type remote controller with 4 malfunction modes.
- (7) All models have service valves protruding from the outdoor unit for faster flare connection work in the field.

(8) Simple design

With the model change, the design has been completely renewed. A simple and modern form with curves harmonizes more with the interior. The suction grill also comes in two segments, simplifying the maintenance.

(9) Amazingly quiet operation

Due to adoption of a newly developed silent stream fan, unpleasant operation sound, such as sound made when the fan runs against the air, has been minimized, thus achieving the trade's lowest noise level in the weak flow mode.

(10) "Aerowing" louver

In order to make air conditioning more comfortable, an "aerowing" louver has been newly developed by applying MHI's advanced aerodynamics, leading to improved air directivity and air conditioning feeling. In the auto swing mode, the louver angle is optimum from 0 (level) to 75°, thus distributing the refreshing air evenly throughout your room. By working the remote controller, you can also set the louver angle easily. The sideways blowout angle can also be set manually up to 45° either right or left side.

11.1.2 How to read the model name

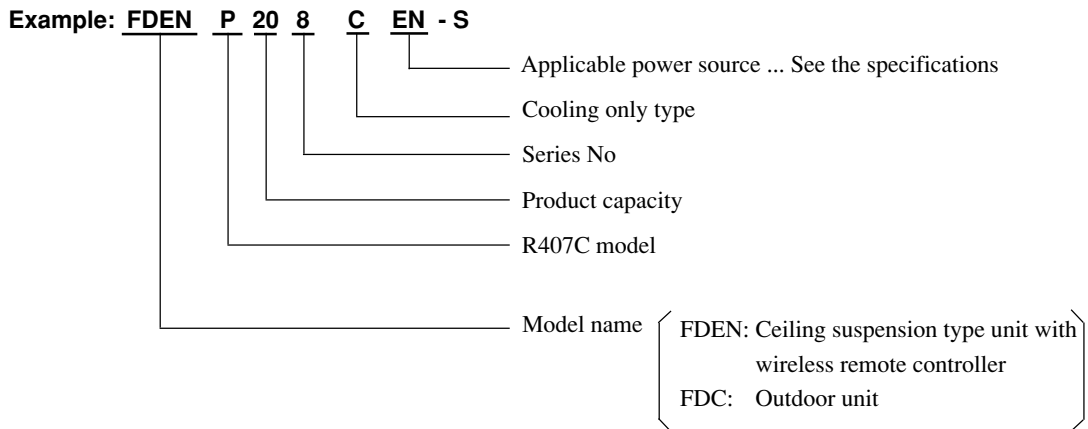

11.2 SELECTION DATA

11.2.1 Specifications

Model **FDENP208CEN-S**

Item		Model	FDENP208CEN-S	
			FDEN208C	FDCP208CEN3
Nominal cooling capacity⁽¹⁾		W	5000	
Power source			1 Phase, 220/240V, 50Hz	
Operation data⁽²⁾	Cooling input	kW	2.04/2.10	
	Running current (Cooling)	A	9.4/9.5	
	Power factor (Cooling)	%	99/92	
	Inrush current (L.R.A)	A	55	
	Noise level ⁽⁴⁾	dB(A)	Hi:43 Lo:38	52
Exterior dimensions				
Height × Width × Depth		mm	184 × 1000 × 650	690 × 880 × 290
Net weight		kg	22	49
Refrigerant equipment				
Compressor type & Q'ty			–	RM5523HNE5 × 1
Motor		kW	–	1.7
Starting method			–	Line starting
Heat exchanger			Louver fins & inner grooved tubing	Slitted fins & bare tubing
Refrigerant control			–	Capillary tube
Refrigerant			R407C	
Quantity		kg	Holding charged	0.87 [Pre-charged up to the piping length of 0m]
Refrigerant oil		ℓ	–	0.7 (MA32)
High pressure control			–	
Air handling equipment				
Fan type & Q'ty			Multiblade centrifugal fan × 2	Propeller fan × 1
Motor		W	40 × 1	55 × 1
Starting method			Line starting	Line starting
Air flow (Standard)		CMM	Hi:14 Lo:10	55
Fresh air intake			Unavailable	–
Air filter, Q'ty			Polypropylene net × 2 (washable)	–
Shock & vibration absorber			Rubber sleeve (for fan motor)	Rubber mount (for compressor)
Electric heater		W	–	20 (Crank case heater)
Operation control				
Operation switch			Wireless remote control switch	– (Indoor unit side)
Room temperature control			Thermostat by electronics	–
Safety equipment				
			Internal thermostat for fan motor. Frost protection thermostat.	Internal thermostat for fan motor. Thermistor for discharge temperature. High pressure switch for protection.
Installation data		mm		
Refrigerant piping size		(in)	Liquid line: φ6.35 (1/4") Gas line: φ15.88 (5/8")	
Connecting method			Flare piping	
Drain hose			(Connectable with VP20)	–
Insulation for piping			Necessary (both Liquid & Gas lines)	
Accessories			Mounting kit. Wireless remote controller.	
Optional parts			–	

Notes (1) The data are measured at the following conditions.

Item	Indoor air temperature		Outdoor air temperature		Standards
	DB	WB	DB	WB	
Cooling	27°C	19°C	35°C	24°C	ISO-T1, JIS B8616

- (2) This packaged air-conditioner is manufactured and tested in conformity with the following standard.
JIS B8616 "UNITARY AIR-CONDITIONERS"
- (3) The operation data indicate when the air-conditioner is operated at 220/240V 50Hz.
- (4) Indicates the value at mild mode.

Model F DENP258CEN-S

Item		Model	F DENP258CEN-S	
			F DEN258C	F DCP258CEN3
Nominal cooling capacity⁽¹⁾		W	5700	
Power source			1 Phase, 220/240V, 50Hz	
Operation data⁽³⁾	Cooling input	kW	2.35/2.54	
	Running current (Cooling)	A	11.3/12.4	
	Power factor (Cooling)	%	95/85	
	Inrush current (L.R.A)	A	63	
	Noise level ⁽⁴⁾	dB(A)	Hi:44 Lo:39	52
Exterior dimensions				
Height × Width × Depth		mm	184 × 1260 × 650	845 × 880 × 340
Net weight		kg	27	55
Refrigerant equipment				
Compressor type & Q'ty			–	RM5526HNE5 × 1
Motor		kW	–	1.9
Starting method			–	Line starting
Heat exchanger			Louver fins & inner grooved tubing	Slitted fins & bare tubing
Refrigerant control			–	Capillary tube
Refrigerant			R407C	
Quantity		kg	Holding charged	1.07 [Pre-charged up to the piping length of 5m]
Refrigerant oil		ℓ	–	0.7 (MA32)
High pressure control			–	
Air handling equipment				
Fan type & Q'ty			Multiblade centrifugal fan × 4	Propeller fan × 1
Motor		W	25 × 2	55 × 1
Starting method			Line starting	Line starting
Air flow (Standard)		CMM	Hi:16 Lo:10.5	56
Fresh air intake			Unavailable	–
Air filter, Q'ty			Polypropylene net × 2 (washable)	–
Shock & vibration absorber			Rubber sleeve (for fan motor)	Rubber mount (for compressor)
Electric heater		kW	–	20 (Cank case heater)
Operation control				
Operation switch			Wireless remote control switch	– (Indoor unit side)
Room temperature control			Thermostat by electronics	–
Safety equipment				
			Internal thermostat for fan motor. Frost protection thermostat.	Internal thermostat for fan motor. Thermistor for discharge temperature. High pressure switch for protection.
Installation data				
Refrigerant piping size		mm (in)	Liquid line: φ9.52 (3/8") Gas line: φ15.88 (5/8")	
Connecting method			Flare piping	
Drain hose			(Connectable with VP20)	–
Insulation for piping			Necessary (both Liquid & Gas lines)	
Accessories			Mounting kit. Wireless remote controller.	
Optional parts			–	

Notes (1) The data are measured at the following conditions.

Item	Indoor air temperature		Outdoor air temperature		Standards
	DB	WB	DB	WB	
Operation					
Cooling	27°C	19°C	35°C	24°C	ISO-T1, JIS B8616

- (2) This packaged air-conditioner is manufactured and tested in conformity with the following standard.
JIS B8616 "UNITARY AIR-CONDITIONERS"
- (3) The operation data indicate when the air-conditioner is operated at 220/240V 50Hz.
- (4) Indicates the value at mild mode.

Model FDENP308CEN-S

Item		Model	FDENP308CEN-S	
			FDEN308C	FDCP308CEN3
Nominal cooling capacity⁽¹⁾		W	7100	
Power source			1 Phase, 220/240V, 50Hz	
Operation data⁽³⁾	Cooling input	kW	3.22/3.37	
	Running current (Cooling)	A	14.9/15.3	
	Power factor (Cooling)	%	98/92	
	Inrush current (L.R.A)	A	95	
	Noise level ⁽⁴⁾	dB(A)	Hi:45 Lo:39	52
Exterior dimensions				
Height × Width × Depth		mm	184 × 126 × 650	845 × 880 × 340
Net weight		kg	27	73
Refrigerant equipment				
Compressor type & Q'ty			-	GT-A5534HN41 × 1
Motor		kW	-	2.5
Starting method			-	Line starting
Heat exchanger			Louver fins & inner grooved tubing	Slitted fins & bare tubing
Refrigerant control			-	Capillary tube
Refrigerant			R407C	
Quantity		kg	Holding charged	1.63 [Pre-charged up to the piping length of 5m]
Refrigerant oil		ℓ	-	1.45 (MA32)
High pressure control			-	
Air handling equipment				
Fan type & Q'ty			Multiblade centrifugal fan × 4	Propeller fan × 1
Motor		W	35 × 2	55 × 1
Starting method			Line starting	Line starting
Air flow (Standard)		CMM	Hi:16.5 Lo:11.5	58
Fresh air intake			Unavailable	-
Air filter, Q'ty			Polypropylene net × 2 (washable)	-
Shock & vibration absorber			Rubber sleeve (for fan motor)	Rubber mount (for compressor)
Electric heater		W	-	33 (Crank case heater)
Operation control				
Operation switch			Wireless remote control switch	- (Indoor unit side)
Room temperature control			Thermostat by electronics	-
Safety equipment				
			Internal thermostat for fan motor. Frost protection thermostat.	Internal thermostat for fan motor. Thermistor for discharge temperature. High pressure switch for protection.
Installation data				
Refrigerant piping size		mm (in)	Liquid line: φ9.52 (3/8") Gas line: φ15.88 (5/8")	
Connecting method			Flare piping	
Drain hose			(Connectable with VP20)	-
Insulation for piping			Necessary (both Liquid & Gas lines)	
Accessories			Mounting kit. Wireless remote controller.	
Optional parts			Decorative Panel	

Notes (1) The data are measured at the following conditions.

Operation	Item	Indoor air temperature		Outdoor air temperature		Standards
		DB	WB	DB	WB	
Cooling		27°C	19°C	35°C	24°C	ISO-T1, JIS B8616

- (2) This packaged air-conditioner is manufactured and tested in conformity with the following standard.
JIS B8616 "UNITARY AIR-CONDITIONERS"
- (3) The operation data indicate when the air-conditioner is operated at 220/240V 50Hz.
- (4) Indicates the value at mild mode.

Model F DENP308CES-S

Item		Model	F DENP308CES-S	
			F DEN308C	F DCP308CES3
Nominal cooling capacity⁽¹⁾		W	7100	
Power source			3 Phase, 380/415V, 50Hz	
Operation data⁽³⁾	Cooling input	kW	3.14/3.29	
	Running current (Cooling)	A	5.5/5.8	
	Power factor (Cooling)	%	87/79	
	Inrush current (L.R.A)	A	45	
	Noise level ⁽⁴⁾	dB(A)	Hi:45 Lo:39	52
Exterior dimensions				
Height × Width × Depth		mm	184 × 1260 × 650	845 × 880 × 340
Net weight		kg	27	73
Refrigerant equipment				
Compressor type & Q'ty			–	GT-A5534HS41 × 1
Motor		kW	–	2.5
Starting method			–	Line starting
Heat exchanger			Louver fins & inner grooved tubing	Slitted fins & bare tubing
Refrigerant control			–	Capillary tube
Refrigerant			R407C	
Quantity		kg	Holding charged	1.63 [Pre-charged up to the piping length of 5m]
Refrigerant oil		ℓ	–	1.45 (MA32)
High pressure control			–	
Air handling equipment				
Fan type & Q'ty			Multiblade centrifugal fan × 4	Propeller fan × 1
Motor		W	35 × 2	55 × 1
Starting method			Line starting	Line starting
Air flow (Standard)		CMM	Hi:16.5 Lo:11.5	58
Fresh air intake			Unavailable	–
Air filter, Q'ty			Polypropylene net × 2 (washable)	–
Shock & vibration absorber			Rubber sleeve (for fan motor)	Rubber mount (for compressor)
Electric heater		W	–	33 (Crank case heater)
Operation control				
Operation switch			Wireless remote control switch	– (Indoor unit side)
Room temperature control			Thermostat by electronics	–
Safety equipment				
			Internal thermostat for fan motor. Frost protection thermostat.	Internal thermostat for fan motor. Thermistor for discharge temperature. High pressure switch for protection.
Installation data				
Refrigerant piping size		mm (in)	Liquid line: φ9.52 (3/8") Gas line: φ15.88 (5/8")	
Connecting method			Flare piping	
Drain hose			(Connectable with VP20)	–
Insulation for piping			Necessary (both Liquid & Gas lines)	
Accessories			Mounting kit. Wireless remote controller.	
Optional parts			Decorative Panel	

Notes (1) The data are measured at the following conditions.

Operation	Item	Indoor air temperature		Outdoor air temperature		Standards
		DB	WB	DB	WB	
Cooling		27°C	19°C	35°C	24°C	ISO-T1, JIS B8616

- (2) This packaged air-conditioner is manufactured and tested in conformity with the following standard.
JIS B8616 "UNITARY AIR-CONDITIONERS"
- (3) The operation data indicate when the air-conditioner is operated at 380/415V 50Hz.
- (4) Indicates the value at mild mode.

Model FDENP408CES-S

Item		Model	FDENP408CES-S	
			FDEN408C	FDCP408CES3
Nominal cooling capacity⁽¹⁾		W	10000	
Power source			3 Phase, 380/415V, 50Hz	
Operation data⁽³⁾	Cooling input	kW	4.51/4.63	
	Running current (Cooling)	A	7.8/8.2	
	Power factor (Cooling)	%	88/79	
	Inrush current (L.R.A)	A	53	
	Noise level ⁽⁴⁾	dB(A)	Hi:49 Lo:43	54
Exterior dimensions				
Height × Width × Depth		mm	239 × 1260 × 650	1050 × 920 × 340
Net weight		kg	34	96
Refrigerant equipment				
Compressor type & Q'ty			-	GU-A5550HS41 × 1
Motor		kW	-	2.8
Starting method			-	Line starting
Heat exchanger			Louver fins & inner grooved tubing	Slitted fins & bare tubing
Refrigerant control			-	Capillary tube
Refrigerant			R407C	
Quantity		kg	Holding charged	2.12 [Pre-charged up to the piping length of 5m]
Refrigerant oil		ℓ	-	1.6 (MA32)
High pressure control			-	
Air handling equipment				
Fan type & Q'ty			Multiblade centrifugal fan × 3	Propeller fan × 2
Motor		W	35 + 55	40 × 2
Starting method			Line starting	Line starting
Air flow (Standard)		CMM	Hi:26 Lo:19	70
Fresh air intake			Unavailable	-
Air filter, Q'ty			Polypropylene net × 3 (washable)	-
Shock & vibration absorber			Rubber sleeve (for fan motor)	Rubber mount (for compressor)
Electric heater		W	-	40 (Crank case heater)
Operation control				
Operation switch			Wireless remote control switch	- (Indoor unit side)
Room temperature control			Thermostat by electronics	-
Safety equipment				
			Internal thermostat for fan motor. Frost protection thermostat.	Internal thermostat for fan motor. Thermistor for discharge temperature. High pressure switch for protection.
Installation data				
Refrigerant piping size		mm (in)	Liquid line: φ9.52 (3/8") Gas line: φ19.05 (3/4")	
Connecting method			Flare piping	
Drain hose			(Connectable with VP20)	-
Insulation for piping			Necessary (both Liquid & Gas lines)	
Accessories			Mounting kit. Wireless remote controller.	
Optional parts			Decorative Panel	

Notes (1) The data are measured at the following conditions.

Operation	Item	Indoor air temperature		Outdoor air temperature		Standards
		DB	WB	DB	WB	
Cooling		27°C	19°C	35°C	24°C	ISO-T1, JIS B8616

- (2) This packaged air-conditioner is manufactured and tested in conformity with the following standard.
JIS B8616 "UNITARY AIR-CONDITIONERS"
- (3) The operation data indicate when the air-conditioner is operated at 380/415V 50Hz.
- (4) Indicates the value at mild mode.

Model F DENP508CES-S

Item		Model	F DENP508CES-S	
			F DEN508C	F DCP508CES3
Nominal cooling capacity⁽¹⁾		W	12500	
Power source			3 Phase, 380/415V, 50Hz	
Operation data⁽³⁾	Cooling input	kW	5.36/5.43	
	Running current (Cooling)	A	9.5/9.8	
	Power factor (Cooling)	%	86/77	
	Inrush current (L.R.A)	A	74	
	Noise level ⁽⁴⁾	dB(A)	Hi:50 Lo:44	55
Exterior dimensions				
Height × Width × Depth		mm	239 × 1470 × 650	1250 × 920 × 340
Net weight		kg	40	105
Refrigerant equipment				
Compressor type & Q'ty			–	GU-A5560HS41 × 1
Motor		kW	–	3.75
Starting method			–	Line starting
Heat exchanger			Louver fins & inner grooved tubing	Slitted fins & bare tubing
Refrigerant control			–	Capillary tube
Refrigerant			R407C	
Quantity		kg	Holding charged	2.58[Pre-charged up to the piping length of 5m]
Refrigerant oil		ℓ	–	1.6 (MA32)
High pressure control			–	
Air handling equipment				
Fan type & Q'ty			Multiblade centrifual fan × 4	Propeller fan × 2
Motor		W	55 × 2	65 × 2
Starting method			Line starting	Line starting
Air flow (Standard)		CMM	Hi:28 Lo:20	110
Fresh air intake			Unavailable	–
Air filter, Q'ty			Polypropylene net × 3 (washable)	–
Shock & vibration absorber			Rubber sleeve (for fan motor)	Rubber mount (for compressor)
Electric heater		W	–	33 (Crank case heater)
Operation control				
Operation switch			Wireless remote control switch	– (Indoor unit side)
Room temperature control			Thermostat by electronics	–
Safety equipment				
			Internal thermostat for fan motor. Frost protection thermostat.	Internal thermostat for fan motor. Thermistor for discharge temperature. High pressure switch for protection.
Installation data				
Refrigerant piping size		mm (in)	Liquid line: φ9.52 (3/8") Gas line: φ19.05 (3/4")	
Connecting method			Flare piping	
Drain hose			(Connectable with VP25)	–
Insulation for piping			Necessary (both Liquid & Gas lines)	
Accessories			Mounting kit. Wireless remote controller.	
Optional parts			Decorative Panel	

Notes (1) The data are measured at the following conditions.

Item	Indoor air temperature		Outdoor air temperature		Standards
	DB	WB	DB	WB	
Cooling	27°C	19°C	35°C	24°C	ISO-T1, JIS B8616

- (2) This packaged air-conditioner is manufactured and tested in conformity with the following standard.
JIS B8616 "UNITARY AIR-CONDITIONERS"
- (3) The operation data indicate when the air-conditioner is operated at 380/415V 50Hz.
- (4) Indicates the value at mild mode.

11.2.2 Range of usage & limitations

Models	FDENP208, 258 type	FDENP308, 408, 508 type
Item		
Indoor return air temperature (Upper, lower limits)	Refer to the selection chart	
Outdoor air temperature (Upper, lower limits)	Refer to the selection chart	
Refrigerant line (one way) length	Max. 30m	Max. 50m
Vertical height difference between outdoor unit and indoor unit	Max. 20m (Outdoor unit is higher) Max. 15m (Outdoor unit is lower)	Max. 30m (Outdoor unit is higher) Max. 15m (Outdoor unit is lower)
Power source voltage	Rating \pm 10%	
Voltage at starting	Min. 85% of rating	
Frequency of ON-OFF cycle	Max. 10 times/h	
ON and OFF interval	Max. 3 minutes	

11.2.3 Exterior dimensions

(1) Indoor unit

Models **FDEN208C, 258C, 308C**

Unit: mm

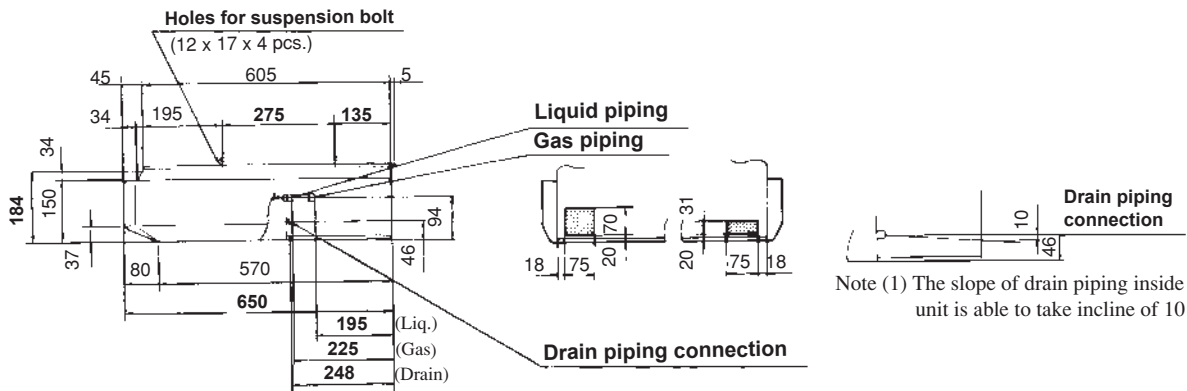
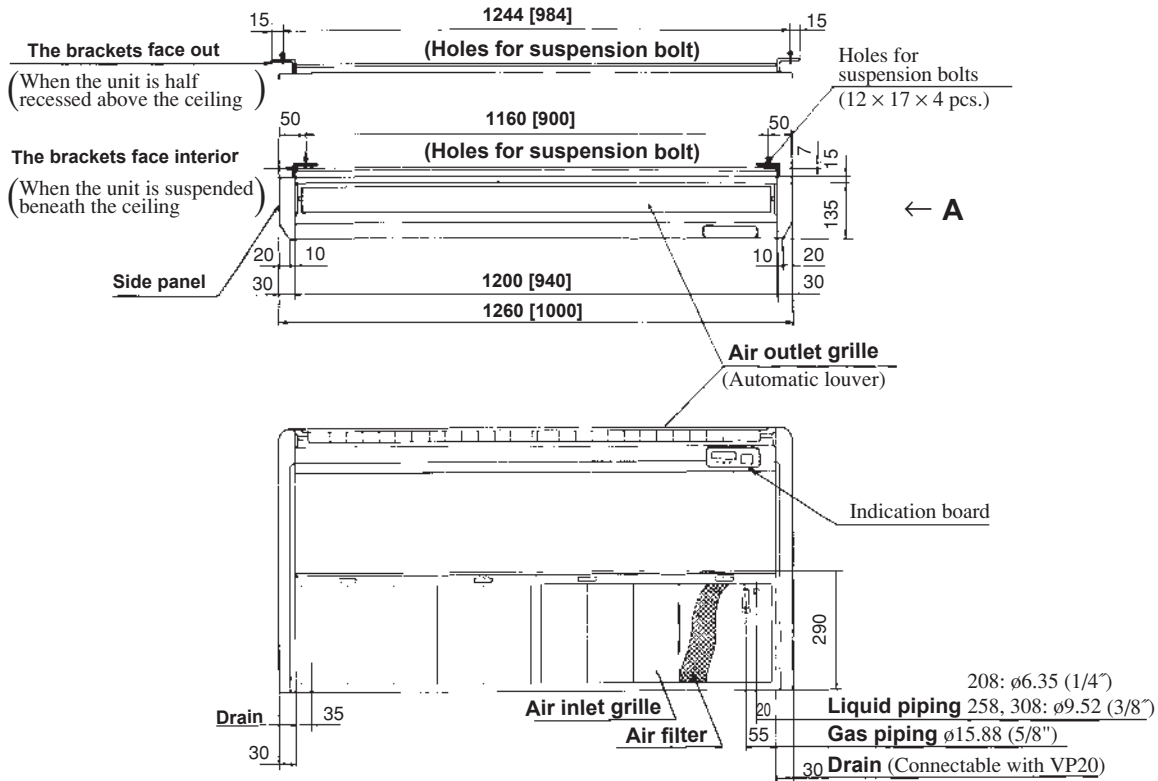

VIEW A

Space for installation & servicing

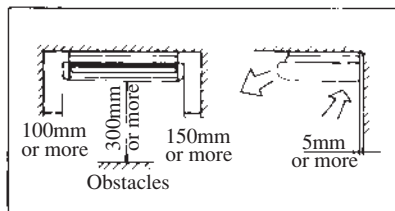

Piping & wiring draw out holes

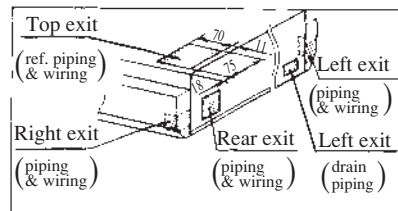

Note (1) The [] value dimension for models FDEN208C.

Models FDEN408C, 508C

Unit: mm

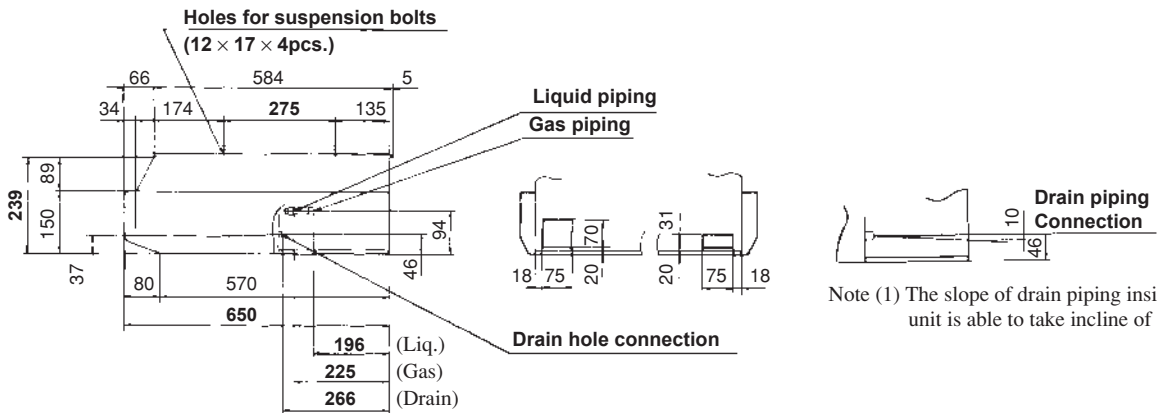
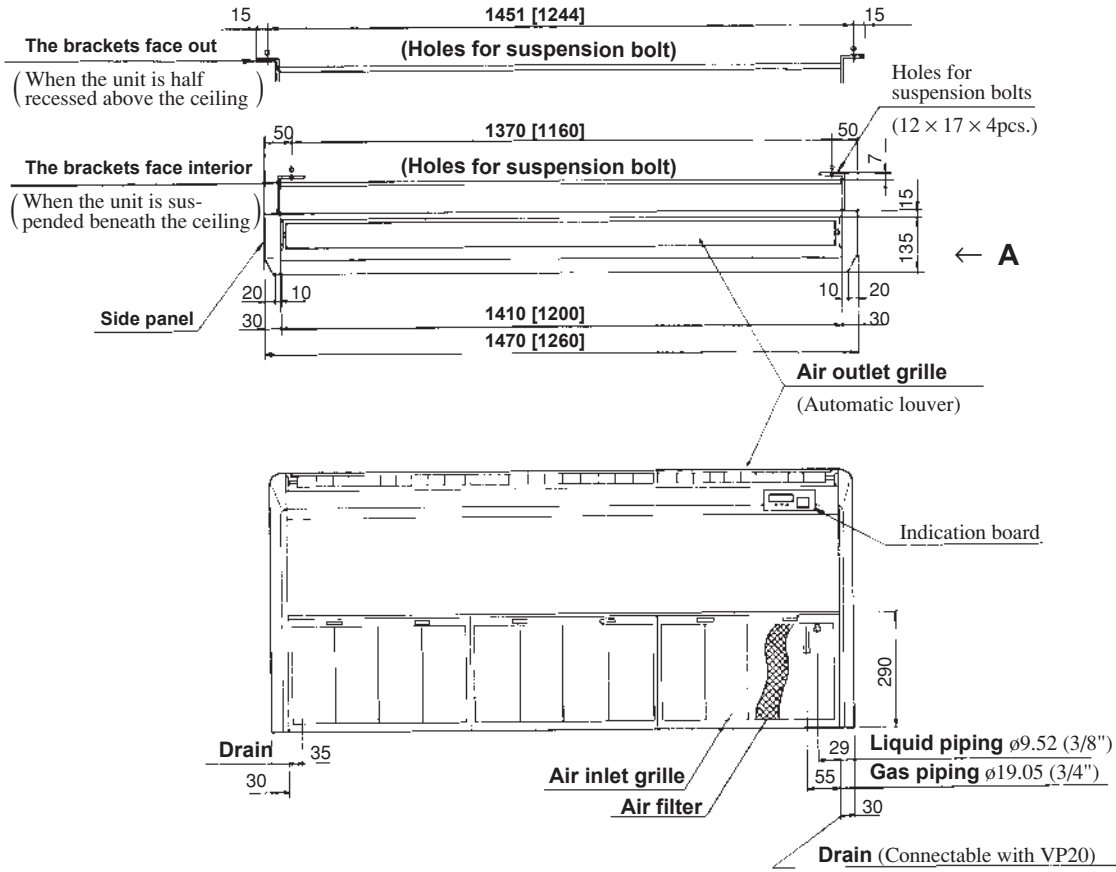

VIEW A

Note (1) The slope of drain piping inside the unit is able to take incline of 10 mm.

Space for installation & servicing

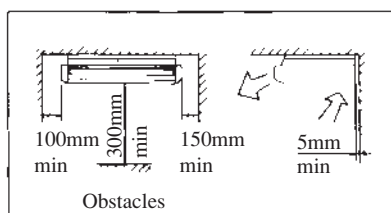

Piping & wiring draw out holes

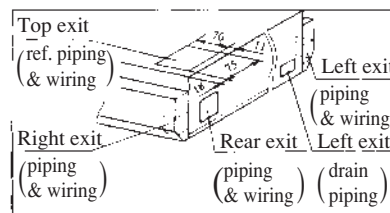

Note (1) The [] value dimension for models FDEN408C

(2) Remote controller

(a) Wireless remote controller

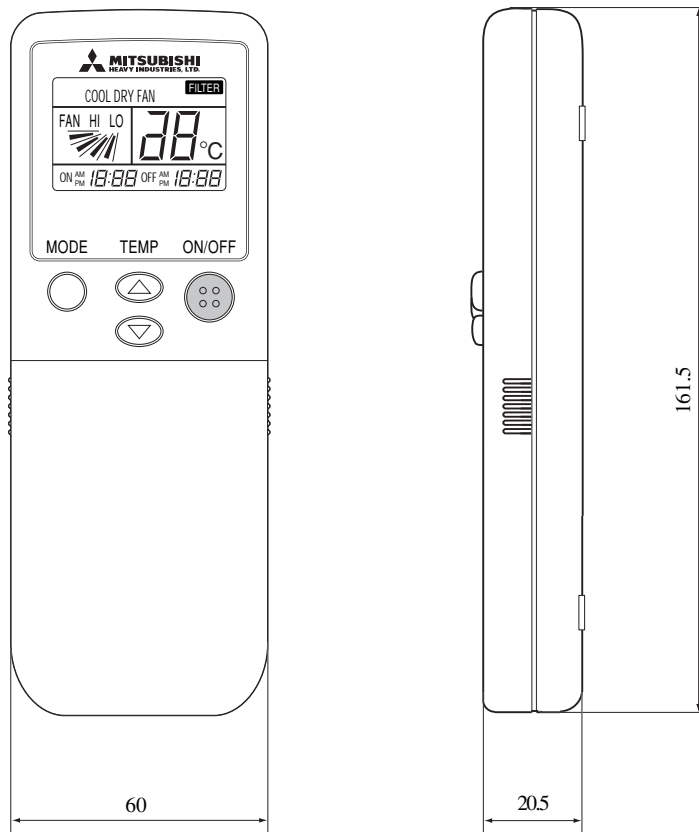

(b) Indication board of indoor unit

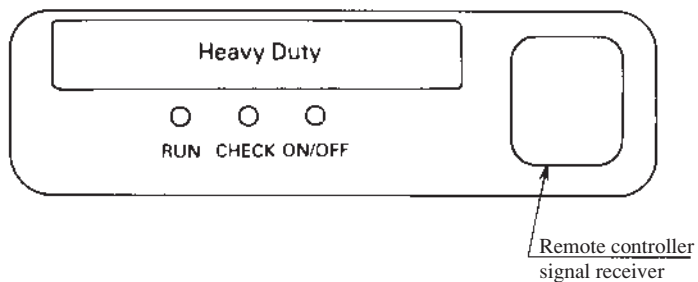

(3) Outdoor unit
Model FDCP208CEN3

Unit: mm

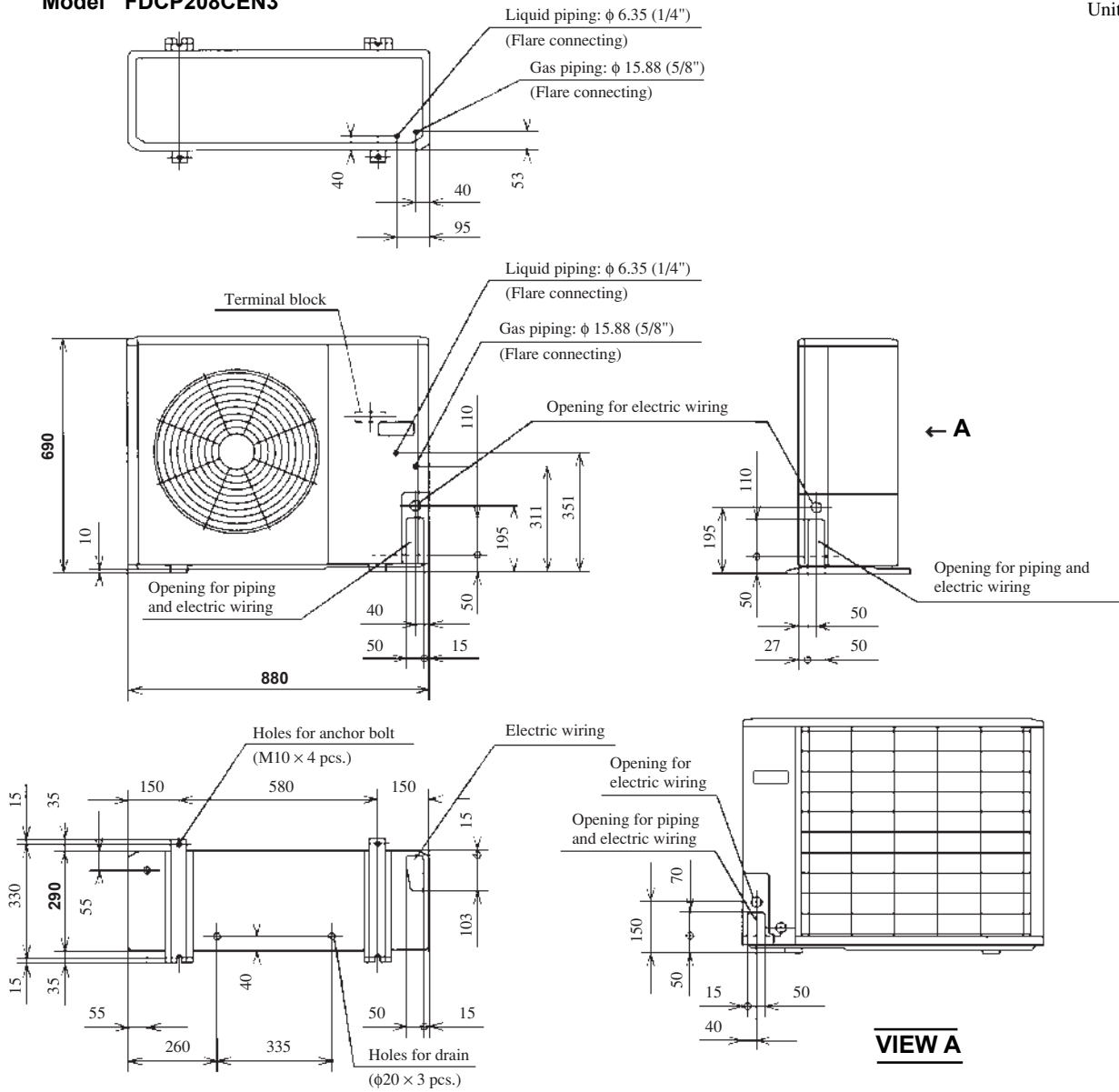

Required space for maintenance and air flow

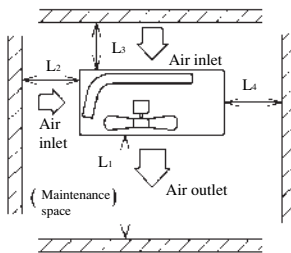

Minimum allowable space to the obstacles

Unit:mm

Mark	Installation type		
	I	II	III
L1	Open	Open	500
L2	300	5	Open
L3	100	150	100
L4	5	5	5

Notes

- (1) Avoid the location where four sides are entirely surrounded by walls.**
- (2) Fix the unit by anchor bolts without fail. Restrict the protrusion length of anchor bolt to 15 mm and under.**
- (3) When strong wind blows against the unit, direct the discharge port at a right angle to the wind direction.**
- (4) Secure the space of 1 m and over at the top of unit.**
- (5) Make the height of obstruction wall in front of discharge port lower than the height of unit.**

Models FDCP258CEN3, 308CEN3, 308CES3

Unit: mm

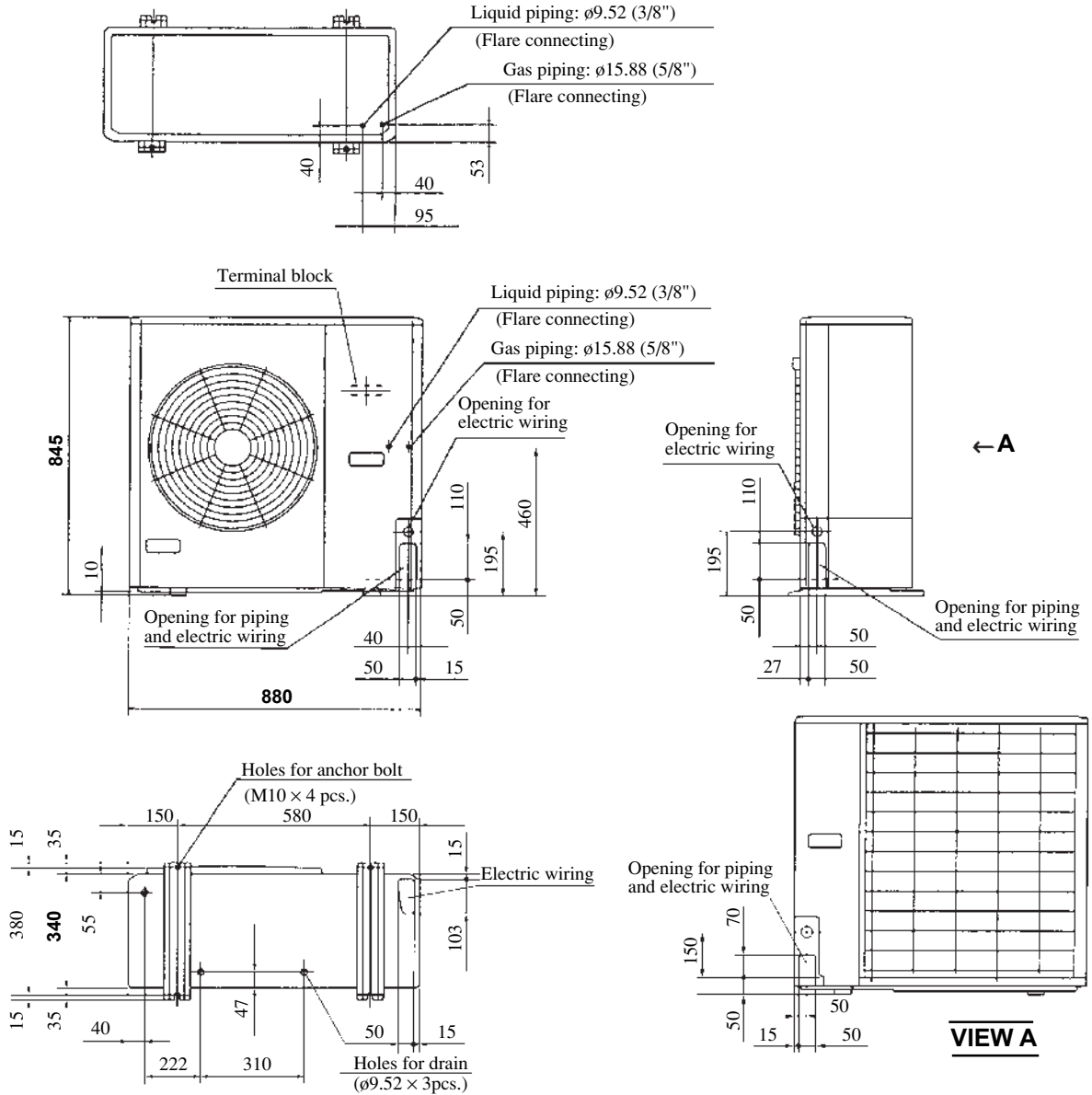

Required space for maintenance and air flow

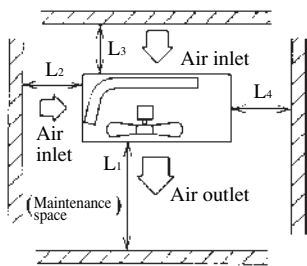

Minimum allowable space to the obstacles

Unit:mm

Mark	Installation type		
	I	II	III
L ₁	Open	Open	500
L ₂	300	5	Open
L ₃	100	150	100
L ₄	5	5	5

Notes

- (1) Avoid the location where four sides are entirely surrounded by walls.
- (2) Fix the unit by anchor bolts without fail. Restrict the protrusion length of anchor bolt to 15 mm and under.
- (3) When strong wind blows against the unit, direct the discharge port at a right angle to the wind direction.
- (4) Secure the space of 1 m and over at the top of unit.
- (5) Make the height of obstruction wall in front of discharge port lower than the height of unit.

Models FDCP408CES3, 508CES3

Unit: mm

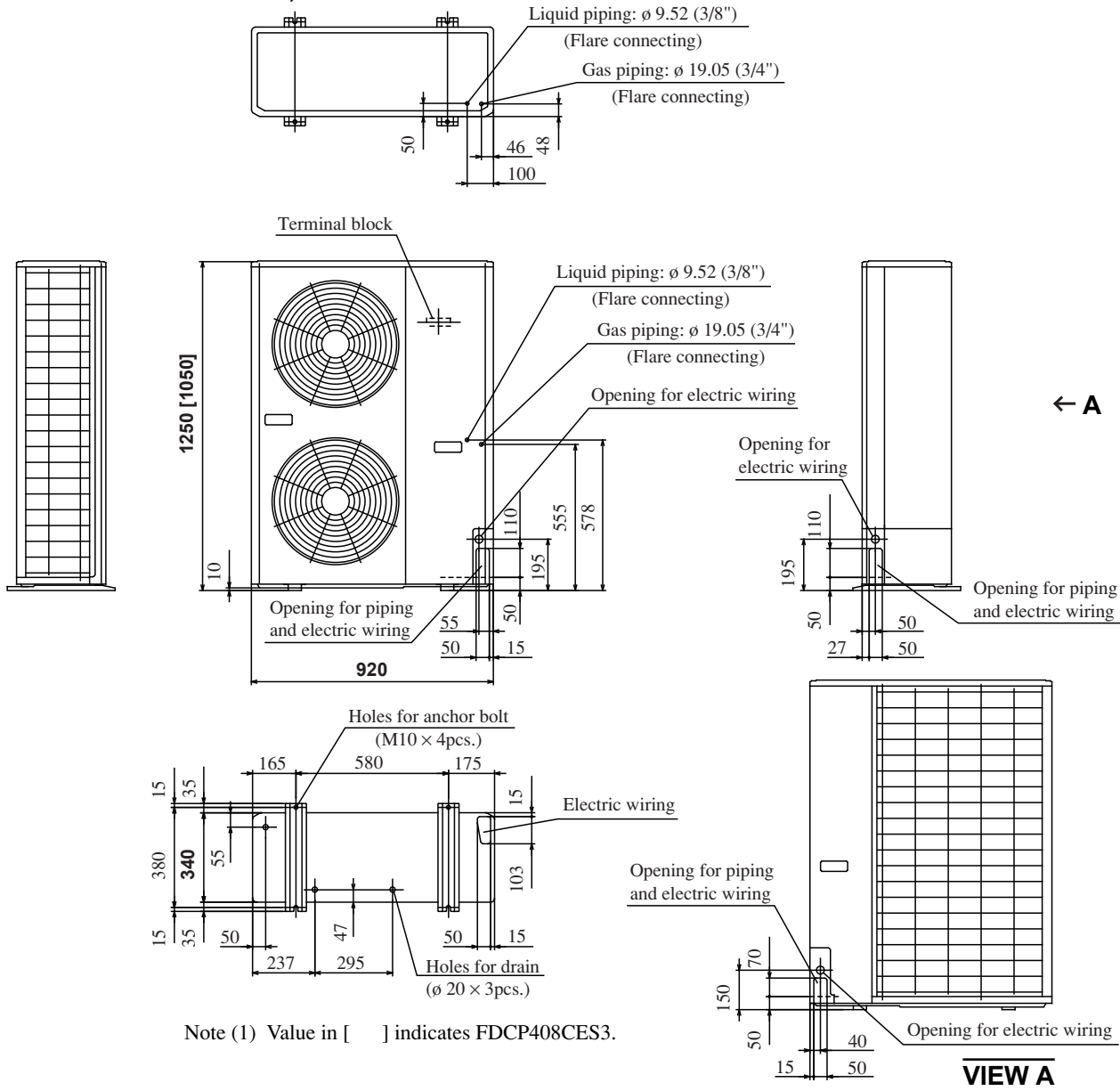

Note (1) Value in [] indicates FDCP408CES3.

VIEW A

Required space for maintenance and air flow

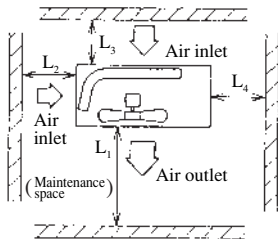

Minimum allowable space to the obstacles

Unit:mm

Installation type	I	II	III
Mark			
L ₁	Open	Open	500
L ₂	300	5	Open
L ₃	150	300	150
L ₄	5	5	5

Notes

- (1) Avoid the location where four sides are entirely surrounded by walls.
- (2) Fix the unit by anchor bolts without fail. Restrict the protrusion length of anchor bolt to 15 mm and under.
- (3) When strong wind blows against the unit, direct the discharge port at a right angle to the wind direction.
- (4) Secure the space of 1 m and over at the top of unit.
- (5) Make the height of obstruction wall in front of discharge port lower than the height of unit.

11.2.4 Exterior appearance

- (1) Indoor unit
Models All models

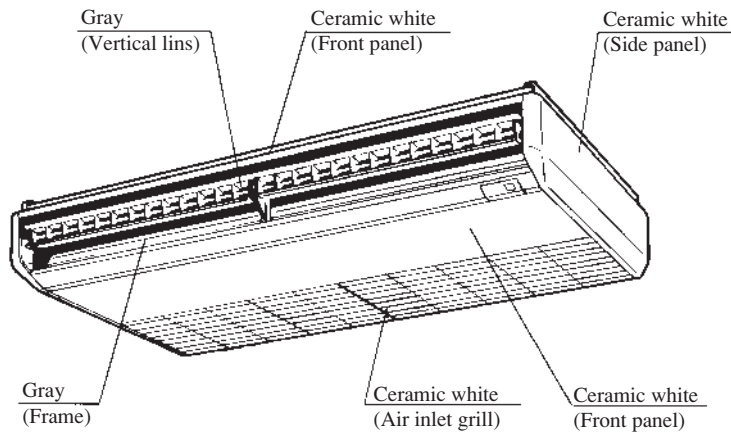

- (2) Outdoor unit
Model FDCP208CEN3

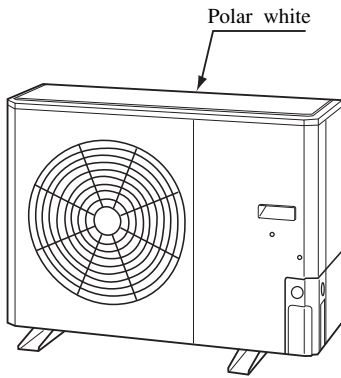

- Models FDCP258CEN3, 308CEN3, 308CES3**

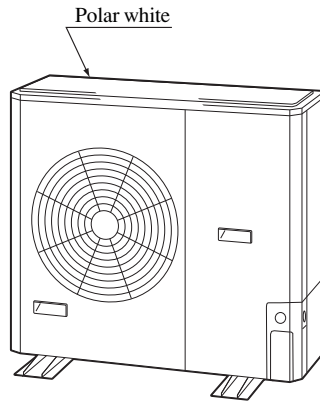

- Models FDCP408CES3, 508CES3**

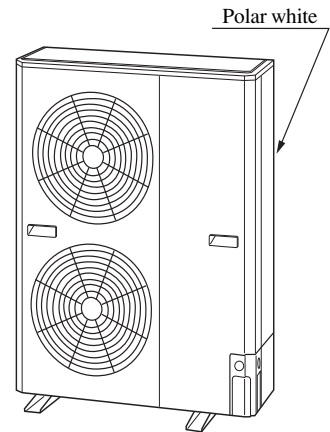

11.2.5 Piping system

Models **FDENP208CEN-S, 258CEN-S**

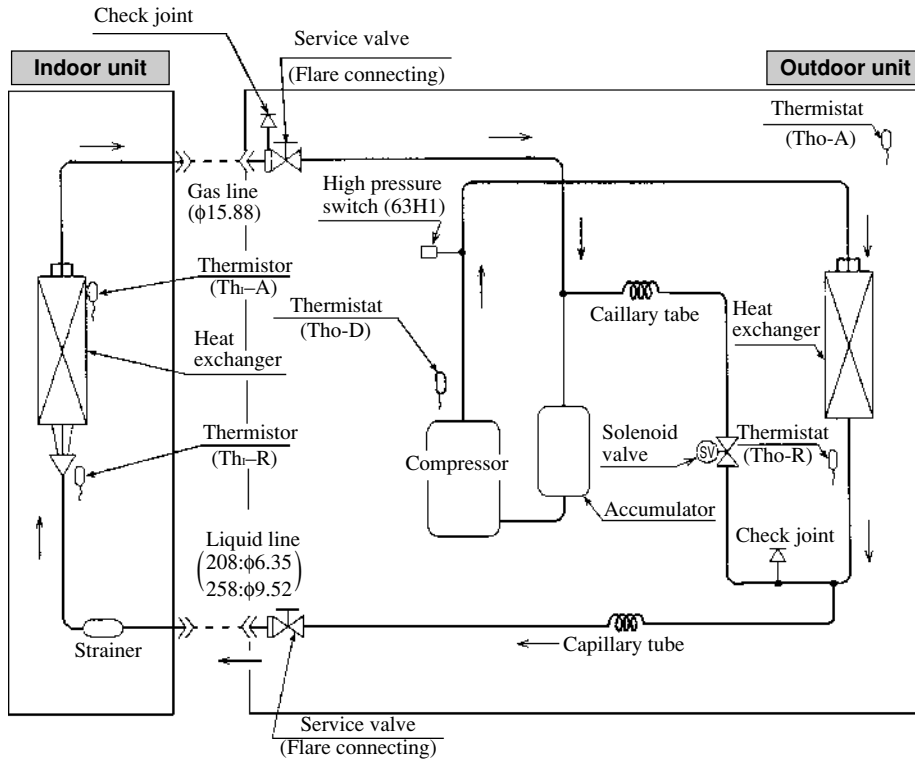

Models **FDENP308CEN-S, 308CES-S, 408CES-S**

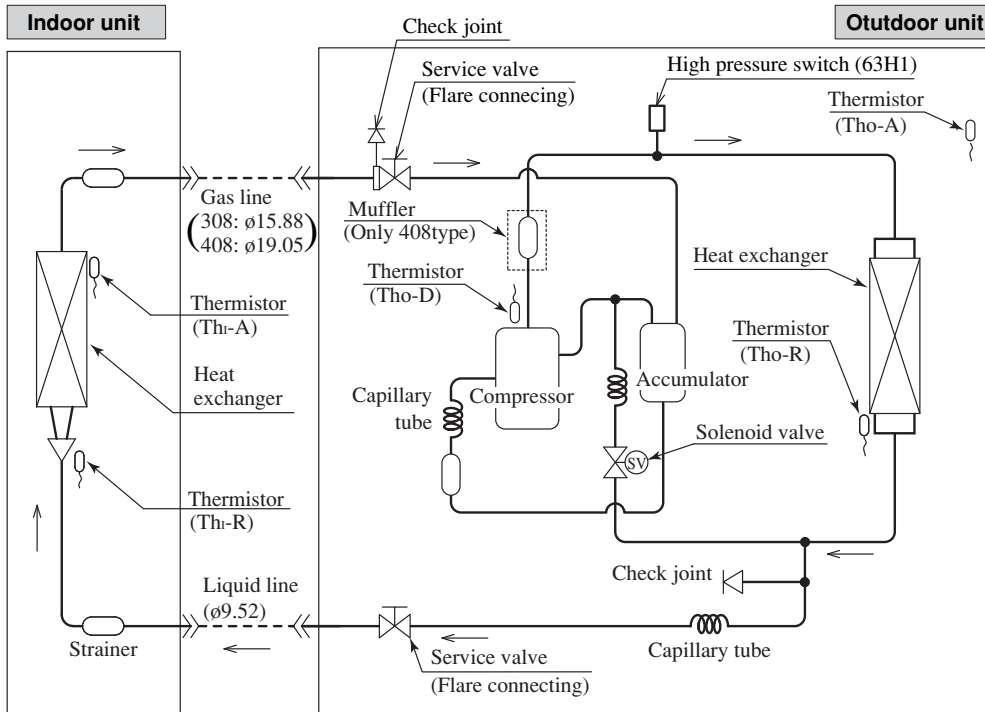

Model **FDENP508CES-S**

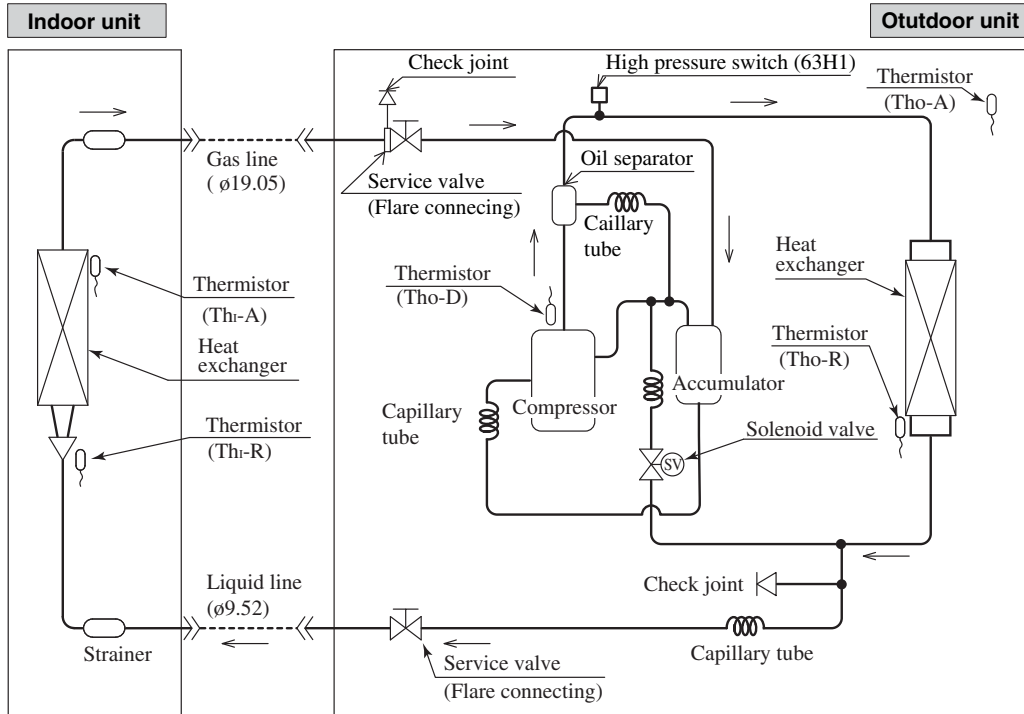

Preset point of the protective devices

Parts name	Mark	Equipped unit	All models
Thermistor (for frost prevention)	Thi-R	Indoor unit	OFF 2.5°C ON 10°C
Thermistor (for detecting discharge pipe temp.)	Tho-D	Outdoor unit	OFF 135°C ON 90°C
Thermistor (for detecting heat exchanger temp.)	Tho-R	Outdoor unit	OFF 70°C ON 60°C
High pressure switch (for protection)	63Hi	Outdoor unit	OFF 3.24MPa (33 Kgf/cm ²) ON 2.65MPa (27 kgf/cm ²)

11.2.6 Selection chart

Correct the cooling capacity in accordance with the conditions as follows. The net cooling capacity can be obtained in the following way.

Net capacity = Capacity shown on specification × Correction factors as follows.

(1) Coefficient of cooling capacity in relation to temperatures

Models FDENP208CEN-S, 258CEN-S

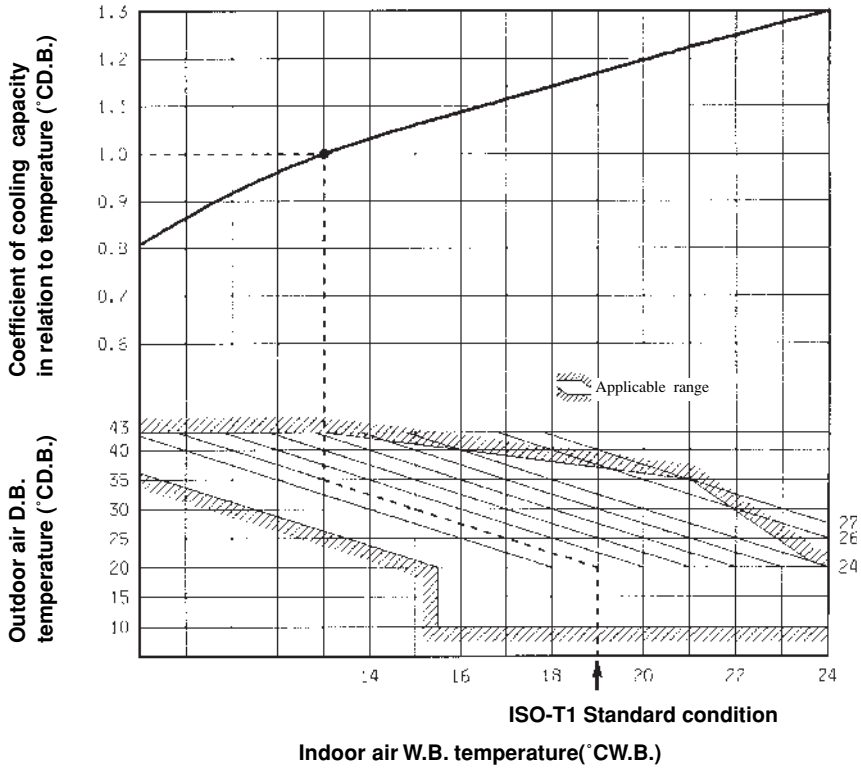

Models FDENP308CEN-S, 408CEN-S, 508CEN-S

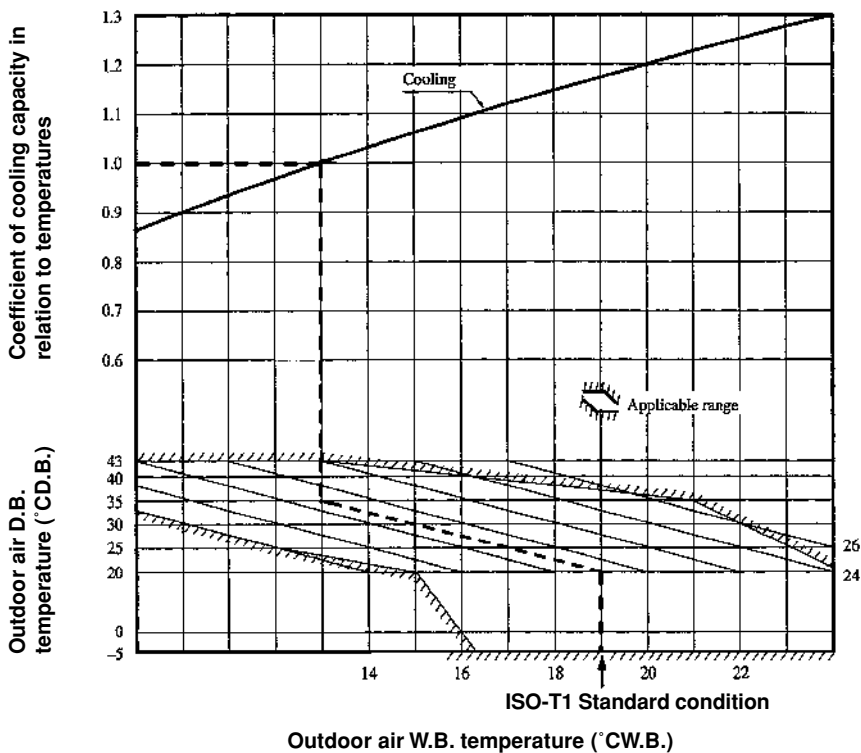

Table of bypass factor

Item \ Model		FDEN208C	FDEN258C	FDEN308C	FDEN408,508C
Air flow	Hi	0.031	0.030	0.036	0.018
	Lo	0.016	0.013	0.018	0.010

(2) Correction of cooling capacity in relation to flow rate control (fan speed)

Coefficient: 1.00 at High, 0.95 at Low

(3) Correction of cooling capacity in relation to one way length of refrigerant piping

It is necessary to correct the cooling capacity in relation to the one way equivalent piping length between the indoor and outdoor units.

Equivalent length ⁽¹⁾ m		5	10	15	20	25	30	35	40	45	50	55
Cooling	FDEN208 type	1.0	0.995	0.995	0.99	0.985	0.985	0.98	-	-	-	-
	FDEN258 type	1.0	0.995	0.99	0.985	0.98	0.975	0.97	-	-	-	-
	FDEN308 type	1.0	0.99	0.98	0.97	0.96	0.95	0.94	0.93	0.92	0.91	0.9
	FDEN408 type	1.0	0.995	0.985	0.98	0.97	0.965	0.955	0.95	0.94	0.935	0.925
	FDEN508 type	1.0	0.99	0.975	0.965	0.95	0.94	0.925	0.915	0.9	0.89	0.875

Note (1) Equivalent piping length can be obtained by calculating as follows.

208, 258, 308 series [φ15.88(5/8")]: Equivalent piping length = Real piping length + (0.10 × Number of bends in piping)

408, 508, series [φ19.05(3/4")]: Equivalent piping length = Real piping length + (0.15 × Number of bends in piping)

[Equivalent piping length < Limitation length of piping + 5m]

(4) When the outdoor unit is located at a lower height than the indoor unit in cooling operation, the following values should be subtracted from the values in the above table.

Height difference between the indoor unit and outdoor unit in the vertical height difference	5m	10m	15m
Adjustment coefficient	0.01	0.02	0.03

Piping length limitations

Item \ Model	FDEN208, 258 type	FDEN308, 408, 508 type
Max.one way piping length	30m	50m
Max.vertical height difference	20m(Outdoor unit is higher) 15m(Outdoor unit is lower)	30m(Outdoor unit is higher) 15m(Outdoor unit is lower)

Note (1) Values in the table indicate the one way piping length between the indoor and outdoor units.

How to obtain the cooling capacity

Example : The net cooling capacity of the model FDENP308CEN-S with the air flow "High", the piping length of 15m, the outdoor unit located 5m lower than the indoor unit, indoor wet-bulb temperature at 19.0 °C and outdoor dry-bulb temperature 35 °C is

$$\text{Net cooling capacity} = \underset{\substack{\uparrow \\ \text{FDENP308CEN-S}}}{7100} \times \underset{\substack{\uparrow \\ \text{Air flow "High"}}}{1.00} \times \underset{\substack{\uparrow \\ \text{Length 15m.} \\ \text{Height difference 5 m}}}{(0.98 - 0.01)} \times \underset{\substack{\uparrow \\ \text{Factor by air} \\ \text{temperatures}}}{1.0} = 6887 \text{ w}$$

11.2.7 Noise level

Notes (1) The data are based on the following conditions.
 Ambient air temperature: Indoor unit 27°C DB, 19°C WB. Outdoor unit 35°C DB.

Indoor unit
 Measured based on JIS B 8616
 Mike position as below

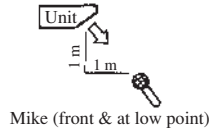

Outdoor unit
 Measured based on JIS B 8616

Mike position: at highest noise level
 in position as below

Distance from front side 1 m
 Height 1 m

- (2) The data in the chart are measured in an anechoic room.
- (3) The noise levels measured in the field are usually higher than the data because of reflection.

(1) Indoor unit

Model FDEN208C

Noise level 43 dB (A) at HIGH
 38 dB (A) at LOW

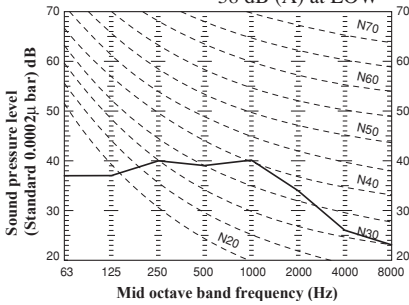

Model FDEN258C

Noise level 44 dB (A) at HIGH
 39 dB (A) at LOW

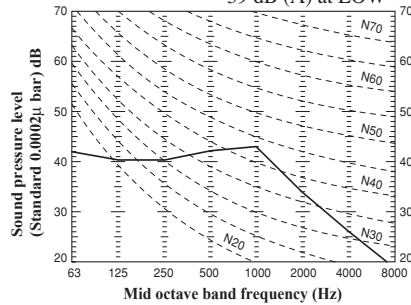

Model FDEN308C

Noise level 45 dB (A) at HIGH
 39 dB (A) at LOW

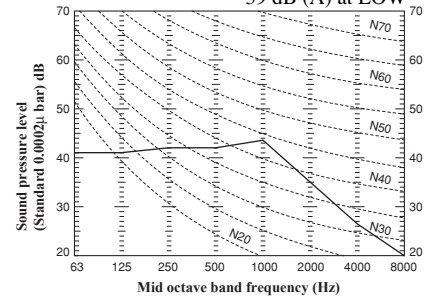

Model FDEN408C

Noise level 49 dB (A) at HIGH
 43 dB (A) at LOW

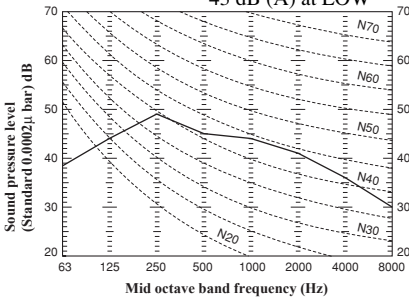

Model FDEN508C

Noise level 50 dB (A) at HIGH
 44 dB (A) at LOW

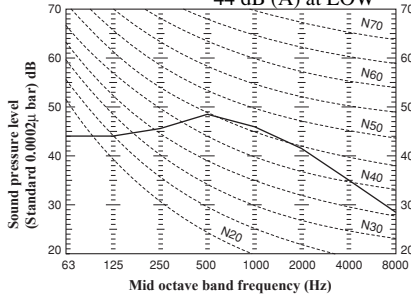

(2) Outdoor unit

Model FDCP208CEN3

Noise level 52dB (A)

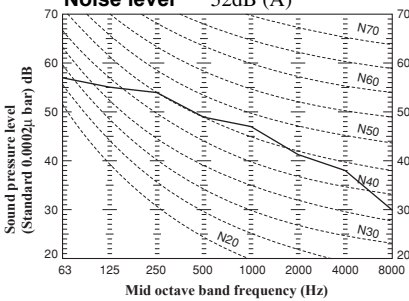

Model FDCP258CEN3

Noise level 52dB (A)

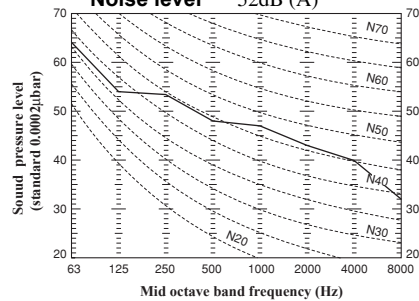

Models FDCP308CEN3, 308CES3

Noise level 52dB (A)

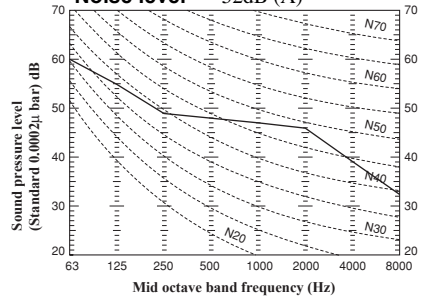

Model FDCP408CES3

Noise level 54dB (A)

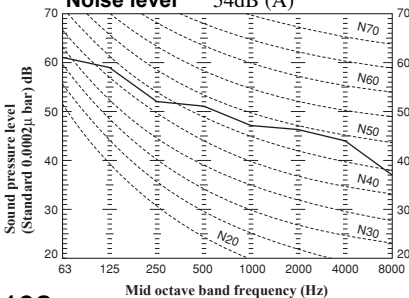

Model FDCP508CES3

Noise level 55dB (A)

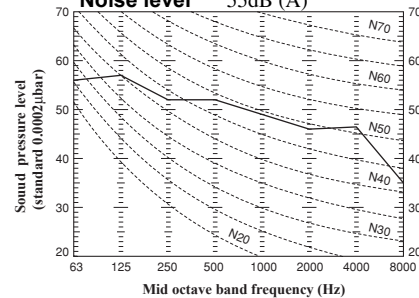

11.3 ELECTRICAL DATA

11.3.1 Electrical wiring

Model **FDENP208CEN-S**

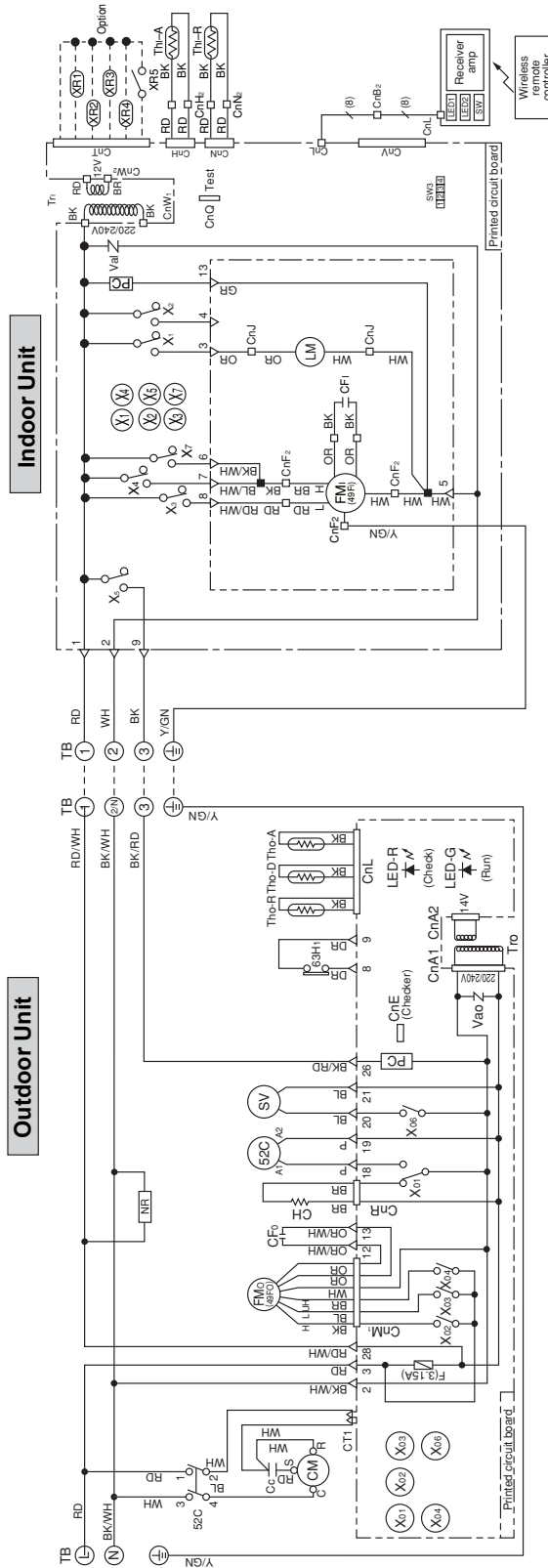

Power Source
1 Phase 220/240V 50Hz

Meaning of marks

Mark	Parts name	Mark	Parts name
Cc	Capacitor for CM	Thi-A	Thermistor
CF1, 2	Capacitor for FMi	Thi-R	Thermistor
CF01, 2	Capacitor for FMo	Tho-A	Thermistor
CH	Crankcase heater	Tho-D	Thermistor
CM	Compressor motor	Tho-R	Thermistor
CnA-W	Connector	Tri, Tro	Transformer
F	Fuse	Vai, Vao	Variator
FMi, 2	Fan motor (Indoor unit)	CT1, 2	Current sensor
FMo1, 2	Fan motor (Outdoor unit)	49Fi	Internal thermostat for FMi
LED1	Indication lamp (Green-Run)	49Fo1, 2	Internal thermostat for FMo
LED2	Indication lamp (Yellow-Check)	63H1	High pressure switch (for protection)
LED-G	Indication lamp (Green)	52C	Magnetic contactor for CM
LED-R	Indication lamp (Red)	X1-7, X01-06	Auxiliary relay
LM	Louver motor	PC	Photo coupler
SV	Solenoid coil (for control)	NR	Surge suppressor
SW	Back up switch (ON/OFF)	▽	Terminal (F)
TB	Terminal block (O mark)	■	Connector

Color mark

Mark	Color	Mark	Color
BK	Black	BK/RD	Black/Red
BL	Blue	BK/WH	Black/White
BR	Brown	OR/WH	Orange/White
GR	Gray	RD/WH	Red/White
OR	Orange	Y/GN	Yellow/Green
P	Pink		
RD	Red		
WH	White		

Models FDENP258CEN-S, 308CEN-S

Power Source
1 Phase 220/240V 50Hz

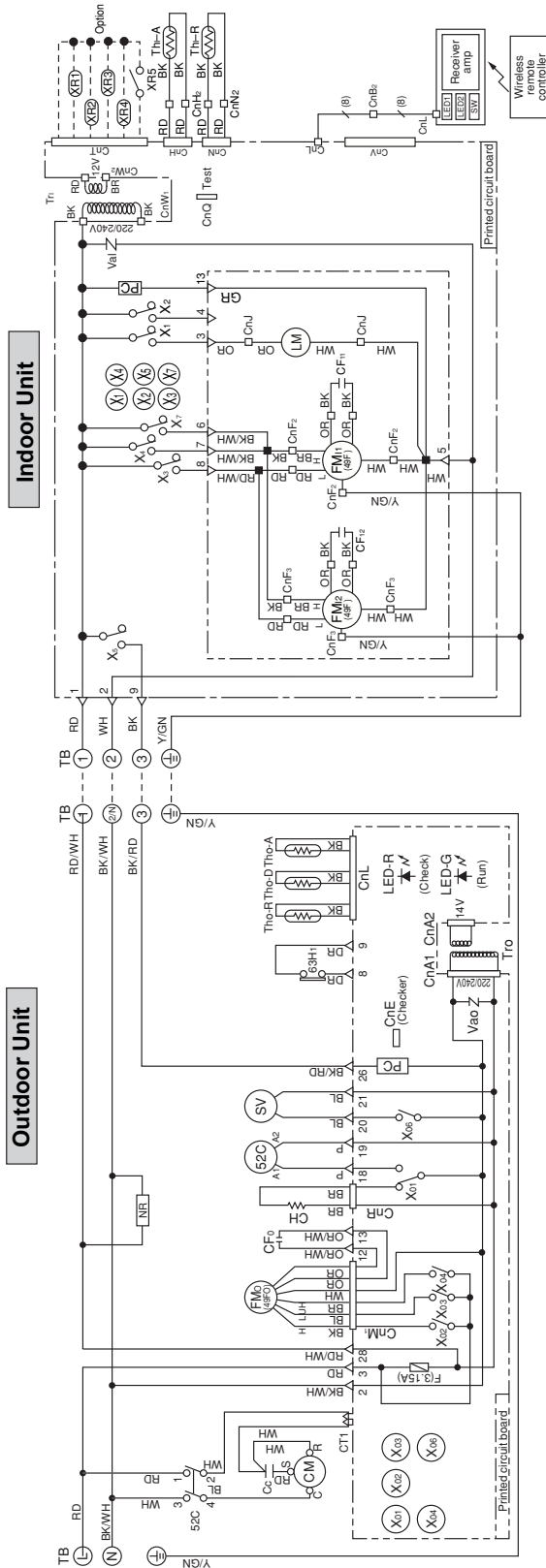

Meaning of marks

Mark	Parts name	Mark	Parts name
CC	Capacitor for CM	Th-A	Thermistor
CF1, 2	Capacitor for FMi	Th-R	Thermistor
CFo	Capacitor for FMo	Th-A	Thermistor
CH	Crankcase heater	Th-D	Thermistor
CM	Compressor motor	Th-R	Thermistor
CnA-W	Connector	Tri, Tro	Transformer
F	Fuse	Vai, Vao	Variator
FM1, 2	Fan motor (Indoor unit)	CT1	Current sensor
FMo	Fan motor (Outdoor unit)	49Fi	Internal thermostat for FMi
LED1	Indication lamp (Green-Run)	49Fo	Internal thermostat for FMo
LED2	Indication lamp (Yellow-Check)	63Hi	High pressure switch (for protection)
LED-G	Indication lamp (Green)	52C	Magnetic contactor for CM
LED-R	Indication lamp (Red)	X1-7, X01-06	Auxiliary relay
LM	Louver motor	PC	Photo coupler
SV	Solenoid coil (for control)	NR	Surge suppressor
SW	Back up switch (ON/OFF)	▽	Terminal (F)
TB	Terminal block (Omark)	■	Connector

Color mark

Mark	Color	Mark	Color
BK	Black	BK/RD	Black/Red
BL	Blue	BK/WH	Black/White
BR	Brown	OR/WH	Orange/White
GR	Gray	RD/WH	Red/White
OR	Orange	Y/GN	Yellow/Green
P	Pink		
RD	Red		
WH	White		

Model FDENP308CES-S

Power Source
3 Phase 380/415V 50Hz

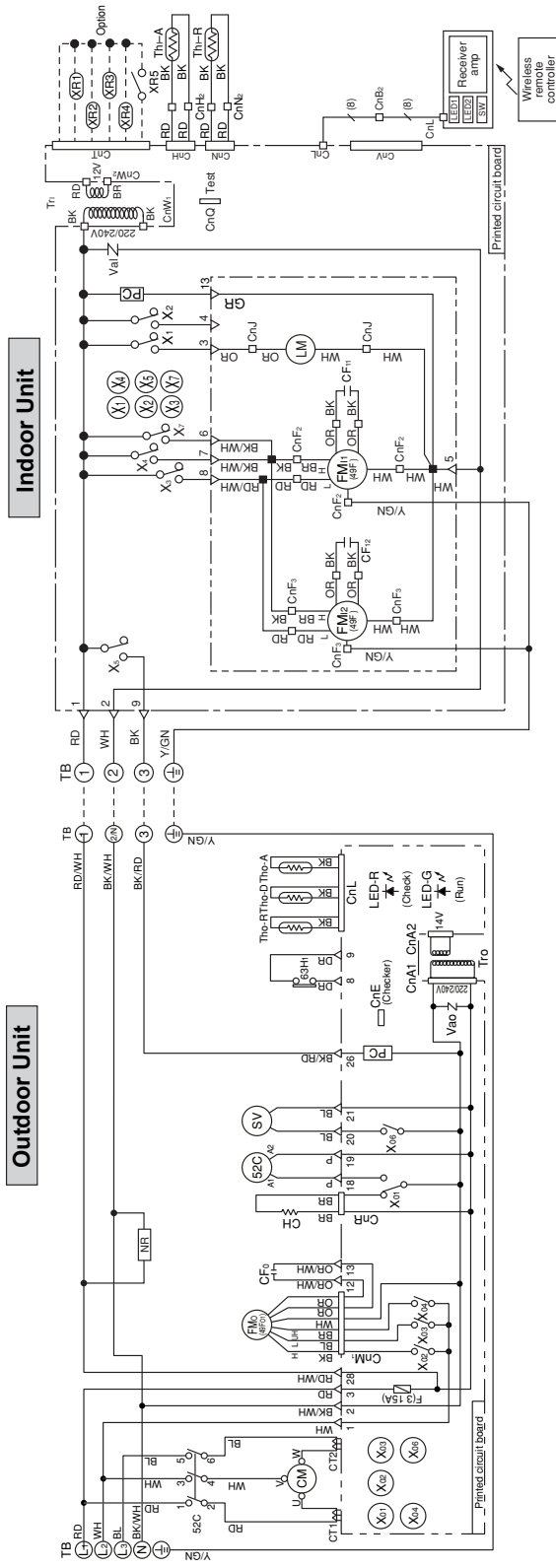

Meaning of marks

Mark	Parts name	Mark	Parts name
CF1, 2	Capacitor for FMi	Thi-R	Thermistor
CFo	Capacitor for FMo	Tho-A	Thermistor
CH	Crankcase heater	Tho-D	Thermistor
CM	Compressor motor	Tho-R	Thermistor
CnA-W	Connector	Tri, Tto	Transformer
F	Fuse	Vai, Vao	Varistor
FMi1, 2	Fan motor (Indoor unit)	CT1, 2	Current sensor
FMo	Fan motor (Outdoor unit)	49Fi	Internal thermostat for FMi
LED1	Indication lamp (Green-Run)	49Fo	Internal thermostat for FMo
LED2	Indication lamp (Yellow-Check)	63Hi	High pressure switch (for protection)
LED-G	Indication lamp (Green)	52C	Magnetic contactor for CM
LED-R	Indication lamp (Red)	X1-7, X01-06	Auxiliary relay
LM	Louver motor	PC	Photo coupler
SV	Solenoid coil (for control)	NR	Surge suppressor
SW	Back up switch (ON/OFF)	Terminal (F)	Terminal (F)
TB	Terminal block (Omark)	Connector	Connector
Thi-A	Thermistor		

Color mark

Mark	Color	Mark	Color
BK	Black	BK/RD	Black/Red
BL	Blue	BK/WH	Black/White
BR	Brown	OR/WH	Orange/White
GR	Gray	RD/WH	Red/White
OR	Orange	Y/GN	Yellow/Green
P	Pink		
RD	Red		
WH	White		

Models FDENP408CES-S, 508CES-S

Power Source
3 Phase 380/415V 50Hz

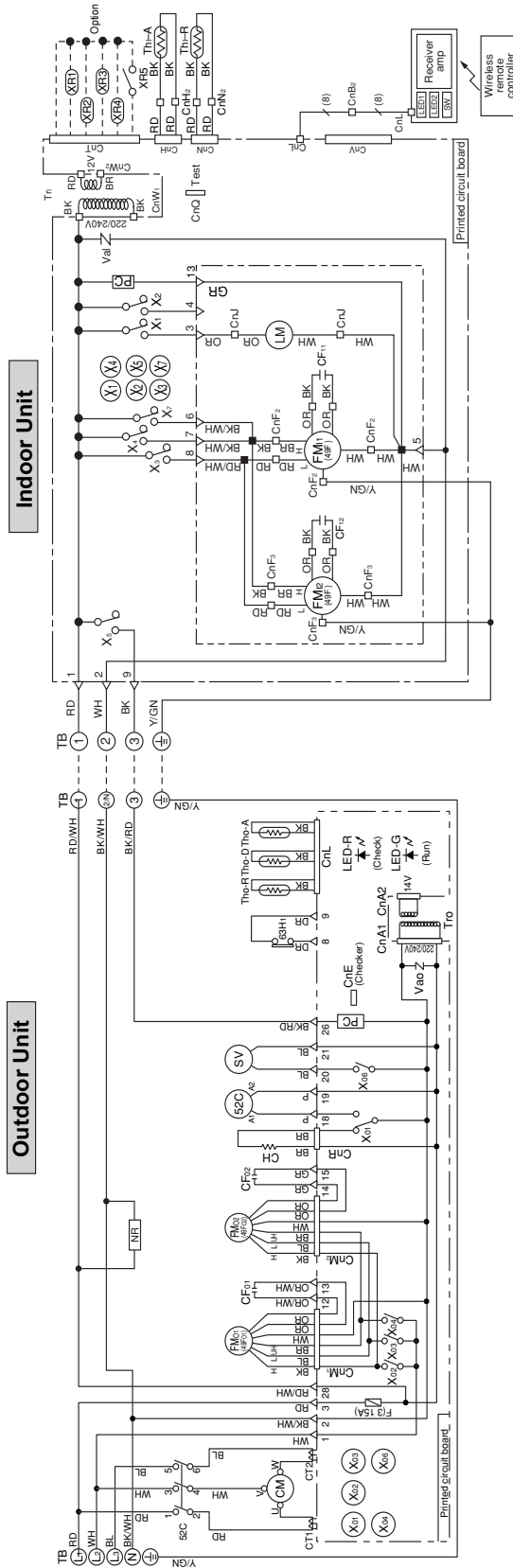

Meaning of marks

Mark	Parts name	Mark	Parts name
CF1, 2	Capacitor for FMI	Thi-R	Thermistor
CF01, 2	Capacitor for FMO	Tho-A	Thermistor
CH	Crankcase heater	Tho-D	Thermistor
CM	Compressor motor	Tho-R	Thermistor
CnA-W	Connector	Tri, Tro	Transformer
F	Fuse	Vai, Vao	Varistor
FM1, 2	Fan motor (Indoor unit)	CT1, 2	Current sensor
FM01, 2	Fan motor (Outdoor unit)	49Fi	Internal thermostat for FMI
LED1	Indication lamp (Green-Run)	49Fo1, 2	Internal thermostat for FMO
LED2	Indication lamp (Yellow-Check)	63H1	High pressure switch (for protection)
LED-G	Indication lamp (Green)	52C	Magnetic contactor for CM
LED-R	Indication lamp (Red)	X1-7, X01-06	Auxiliary relay
LM	Louver motor	PC	Photo coupler
SV	Solenoid coil (for control)	NR	Surge suppressor
SW	Back up switch (ON/OFF)	Terminal (F)	Terminal (F)
TB	Terminal block (Cmark)	■	Connector
Thi-A	Thermistor		

Color mark

Mark	Color	Mark	Color
BK	Black	BK/RD	Black/Red
BL	Blue	BK/WH	Black/White
BR	Brown	OR/WH	Orange/White
GR	Gray	RD/WH	Red/White
OR	Orange	Y/GN	Yellow/Green
P	Pink		
RD	Red		
WH	White		

11.4 OUTLINE OF OPERATION CONTROL BY MICROCOM-PUTER

Except for function relating to heating, same as the unit for FDT(N) heat pump type. See page 317.

11.5 APPLICATION DATA

The application data for the cooling only models are similar to those for the heat pump models. (See page 435.)

11.6 MAINTENANCE DATA

Same as the cooling /heating equipment for FDT(N) heat pump type. Refer to page 348.