

VHF 01, 05, 10 & 12

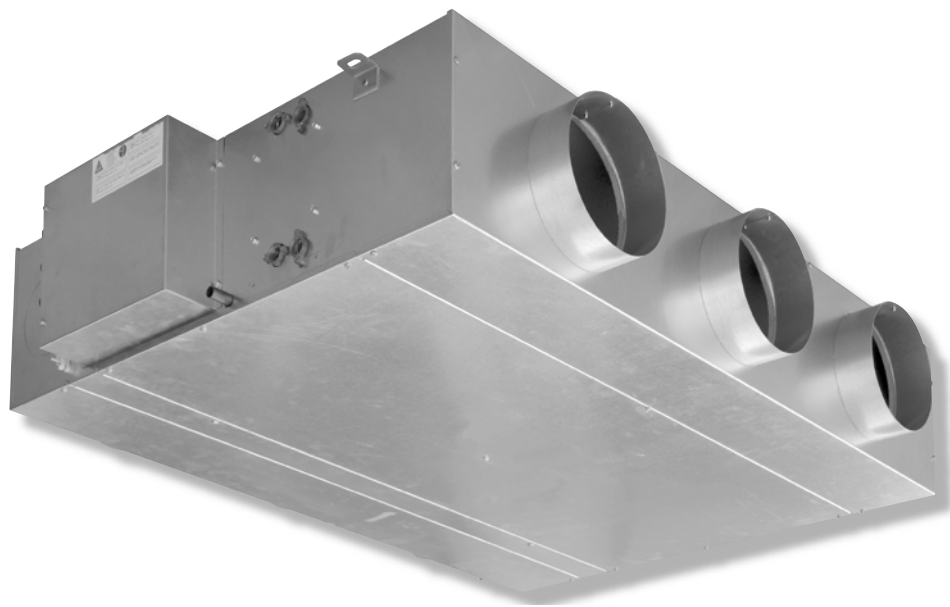

English

Français

Static pressure fan coil units

Ventilo-convecteurs à pression statique

IOM VHF-N.5GBF

Date : **March / Mars 2006**

Supersedes / Annule et remplace : **IOM VHF-N.4GBF/10.05**



INSTALLATION INSTRUCTION

NOTICE D'INSTALLATION

INSTALLATIONSHANDBUCH

ISTRUZIONI INSTALLAZIONE

INSTRUCCIONES DE INSTALACIÓN

English

Français

Deutsch

Italiano

Español

CONTENTS

1 - INTRODUCTION	3
2 - SAFETY PRECAUTIONS	3
3 - DESCRIPTION	4
3.1 - INSPECTION AND STORAGE	4
3.2 - ELECTRICAL CHARACTERISTICS	4
3.3 - OPERATING LIMITS	4
4 - DIMENSIONS AND WEIGHTS	5
4.1 - VHF 01 (APSA/APS/SP)	5
4.2 - VHF 05 (APSA/APS/SP)	6
4.3 - VHF 10 (APSA/APS/SP)	7
4.4 - VHF 12 (APSA/APS/SP)	8
5 - INSTALLATION	9
5.1 - UNIT HANDLING	9
5.2 - LOCATION.....	9
5.3 - INSTALLATION INSTRUCTIONS	10
6 - HYDRAULIC CONNECTIONS	10
6.1 - COIL WATER CONNECTIONS.....	10
6.2 - COIL WATER VOLUME	11
6.3 - CONDENSATE DRAIN CONNECTION.....	11
6.4 - INSTALLATION OF THERMOSTAT OR TEMPERATURE SENSOR (CHANGE OVER)	12
7 - ELECTRICAL CONNECTIONS	13
7.1 - UNIT CONNECTIONS	13
7.2 - REGULATION	13
7.3 - ELECTRIC HEATING RESISTANCES	13
7.4 - WIRING DIAGRAM.....	13
8 - AERAULIC CONNECTIONS	14
9 - PRELIMINARY CHECKS BEFORE COMMISSIONING	16
10 - OPERATION	16
10.1 - AQUANET	16
10.2 - TRM-FA AND TRM-VP	16
10.3 - TAE 20	17
11 - MAINTENANCE	18
11.1 - AIR FILTER.....	18
11.2 - CONDENSATE TRAY	18
11.3 - COILS	18
11.4 - FAN MOTOR ASSEMBLY	19
11.5 - ELECTRICAL CONNECTIONS	19
11.6 - WATER PIPES.....	19
12 - IN-WARRANTY RETURN MATERIAL PROCEDURE	20
13 - SERVICE AND SPARE PARTS ORDER	20

1 - INTRODUCTION

The purpose of this Manual is to provide users with instructions for installing, commissioning, using and maintaining the VHF units.

It does not contain the complete description of all the maintenance operations guaranteeing the unit's long life and reliability. Only the services of a qualified technician can guarantee the unit's safe operation over a long service life.

2 - SAFETY PRECAUTIONS

Please read the following safety precautions very carefully before installing the unit.

Warning

The installation, commissioning and maintenance of these units should be performed by qualified personnel having a good knowledge of standards and local regulations, as well as experience of this type of equipment.

Warning

Any wiring produced on site must comply with the corresponding national electrical regulations.

Warning

Ensure that the electrical supply voltage corresponds to the specification indicated on the unit's maker's plate before proceeding with the connection in accordance with the wiring diagram supplied.

Warning

The unit must be EARTHED to avoid any risks caused by insulation defects.

Warning

No wiring must come in contact with the heat source or the fan rotating parts.

Take care

The unit should be handled using lifting and handling equipment appropriate to the unit's size and weight.

Take care

Before conducting any maintenance operations, check that all electrical supply to the unit is disconnected (230 V single phase and 400 V three phase if additional electric heating resistances of over 3000 W are fitted).

Take care

It is forbidden to start any work on the electrical components if water or high humidity is present on the installation site.

Take care

When making the hydraulic connections, ensure that no impurities are introduced into the pipe work.

THE MANUFACTURER'S WARRANTY WILL NOT APPLY IF THE INSTALLATION INSTRUCTIONS LISTED IN THE PRESENT MANUAL ARE NOT FOLLOWED.

3 - DESCRIPTION

3.1 - INSPECTION AND STORAGE

At the time of receiving the equipment carefully cross check all the elements against the shipping documents in order to ensure that all the crates and boxes have been received. Inspect all the units for any visible or hidden damage.

In the event of shipping damage, write precise details of the damage on the shipper's delivery note and send immediately a registered letter to the shipper within 48 hours, clearly stating the damage caused. Forward a copy of this letter to the manufacturer or their representative.

Never store or transport the unit upside down. It must be stored indoors, completely protected from rain, snow etc. The unit must not be damaged by changes in the weather (high and low temperatures). Excessively high temperatures (above 60 °C) can harm certain plastic materials and cause permanent damage. Moreover, the performance of certain electrical or electronic components can be impaired.

3.2 - ELECTRICAL CHARACTERISTICS

Current absorbed by the motors - 230 V / 1 ph / 50 Hz

Unit size		VHF 01		VHF 05		VHF 10		VHF 12	
		Current absorbed (A) *	Power absorbed (w)*	Current absorbed (A) *	Power absorbed (w)*	Current absorbed (A) *	Power absorbed (w)*	Current absorbed (A) *	Power absorbed (w)*
SPEED	V1	0.19	40	0.37	80	0.60	132	0.60	132
	V2	0.30	68	0.40	85	0.70	152	0.70	152
	V3	0.44	100	0.42	90	0.80	177	0.80	177
	V4	0.61	138	0.45	100	0.91	205	0.93	210
	V5	0.70	160	0.49	105	1.17	267	1.21	278
	V6	0.85	190	0.60	130	/	/	/	/

(*) Maximum current absorbed by the motors operating with 230 V / 1 ph / 50 Hz and with a static pressure of 0 Pa with aspiration filter G2.

VHF 01 equipped with 2 spygots Ø160mm.

VHF 10 equipped with 3 spygots Ø200mm.

VHF 05 equipped with 2 spygots Ø200mm.

VHF 12 equipped with 3 spygots Ø250mm.

Electric heating resistances - 230 V / 1 ph / 50 Hz

Unit size	Capacity (W)					
	BE1	BE2	BE3	BE4	BE5	BE6
VHF 01	600	800	1200	1400	1600	-
VHF 05	500	750	1000	1500	2000	3000
VHF 10 - VHF 12	1000	1200	1500	2000	2400	3600 *

3.3 - OPERATING LIMITS

Water pipes	Maximum operating pressure	10 bar
	Minimum inlet temperature	+ 4 °C
	Maximum inlet temperature	+ 90 °C
Premises air temperature	Minimum temperature	5 °C
	Maximum temperature	32 °C
Supply voltage	230 V ± 10 % / 1 ph / 50 Hz (*)	

(*) In the event that the unit is equipped with electric heating resistances with a capacity greater than 3000 W, a power supply of 400 V three phase + neutral + ground is required.

required. It should be noted that the contactor of power is provided with the electric heating resistances.

4 - DIMENSIONS AND WEIGHTS

4.1 - VHF 01 (APSA/APS/SP)

Dimensions in mm.



21 kg

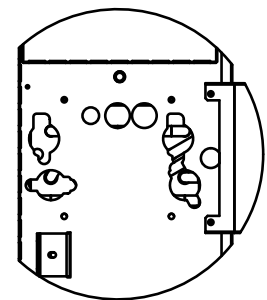
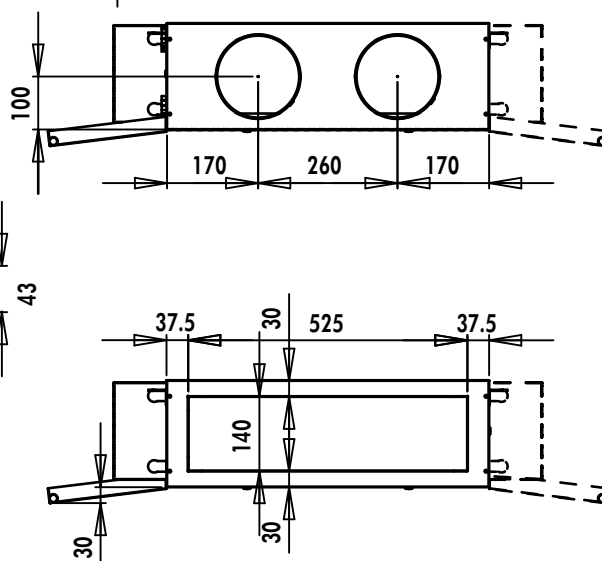
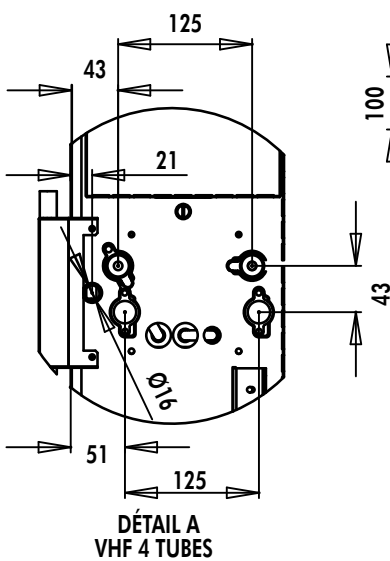
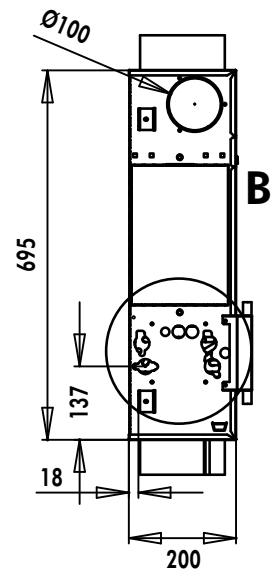
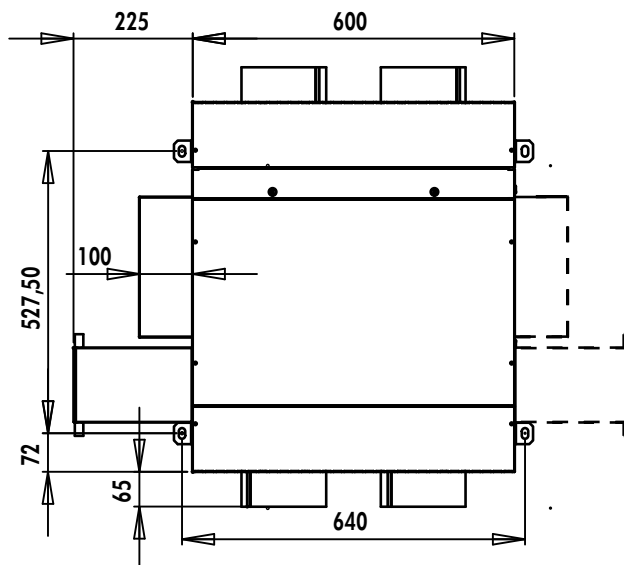
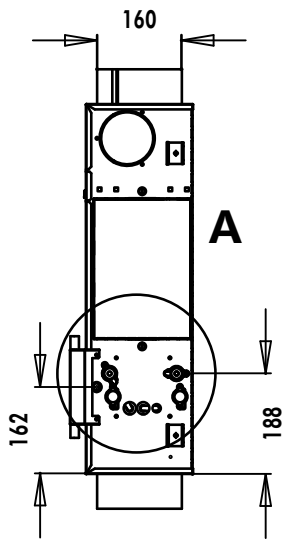
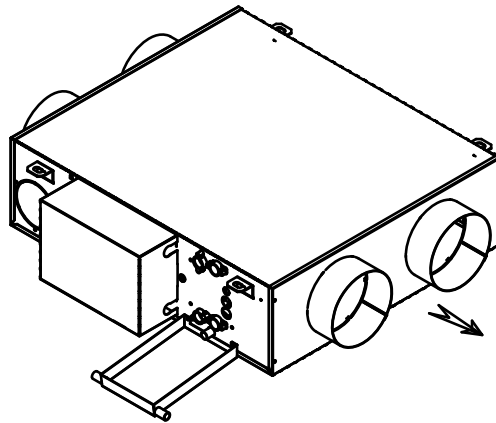

Note : The coil connections are of female threaded type $\text{Ø}1/2''$.

Weight (VHF01 APSA) in functioning order, without valve, regulation and 4 rows coil.

4 - DIMENSIONS AND WEIGHTS (CONTINUED)

4.2 - VHF 05 (APSA/APS/SP)

Dimensions in mm.

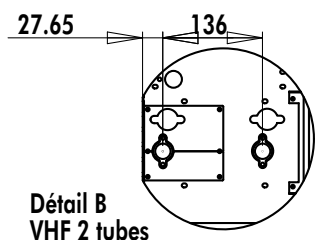
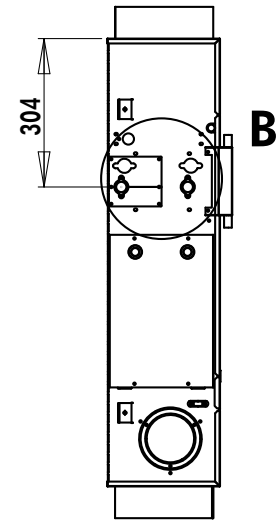
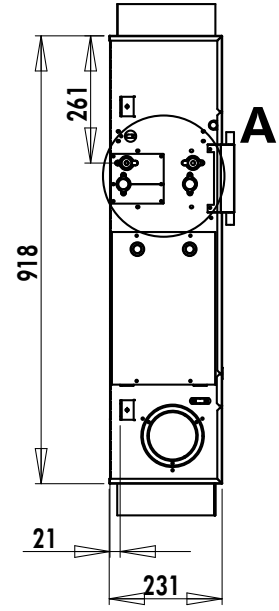
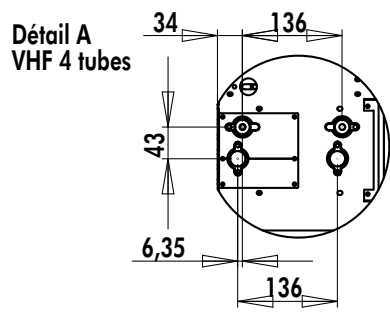
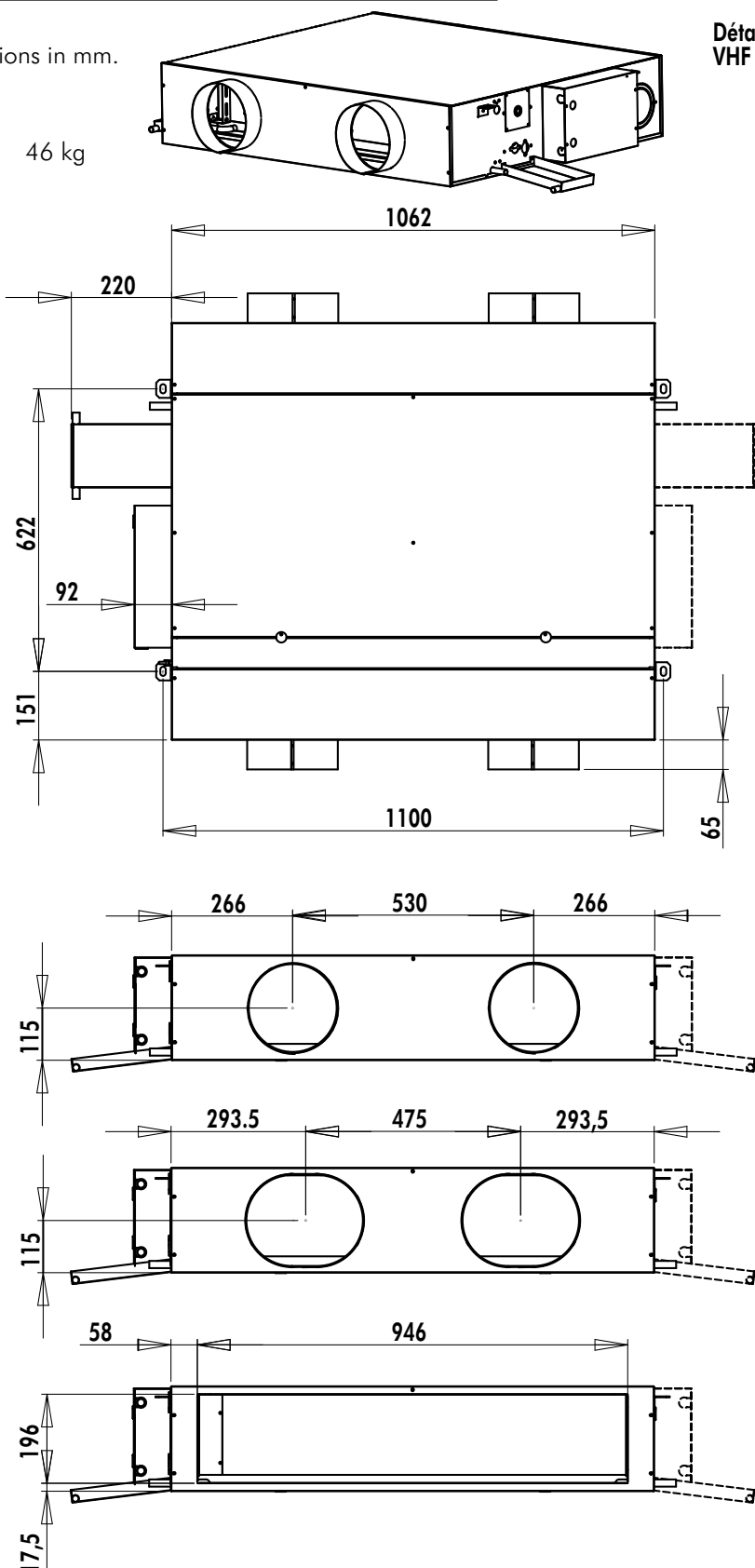

Note : The coil connections are of female threaded type $\text{Ø}1/2"$.

Weight (VHF05 APSA) in functioning order, without valve, regulation and 4 rows coil.

4 - DIMENSIONS AND WEIGHTS (CONTINUED)

4.3 - VHF 10 (APSA/APS/SP)

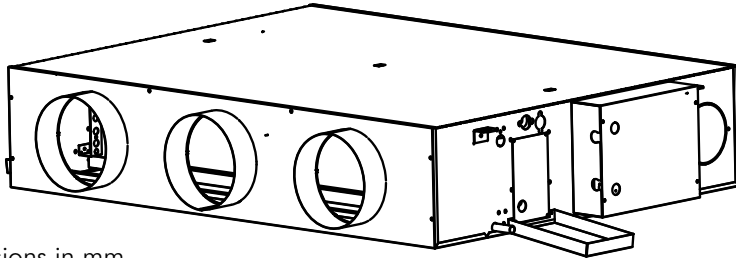

Dimensions in mm.



55 kg

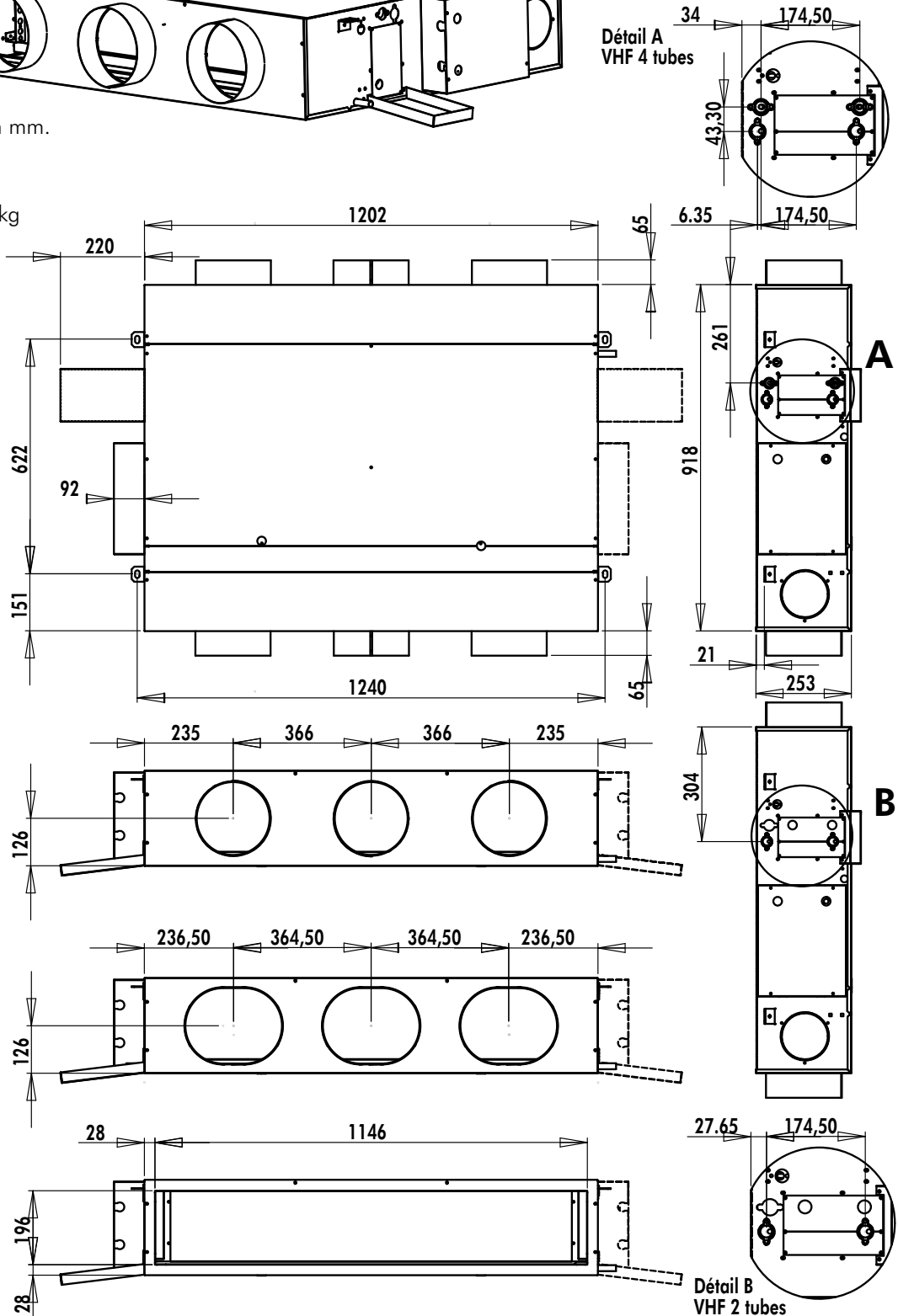

Note : The coil connections are of female threaded type $\text{Ø}1/2"$.

Weight (VHF10 APSA) in functioning order, without valve, regulation and 4 rows coil.

4 - DIMENSIONS AND WEIGHTS (CONTINUED)

4.4 - VHF 12 (APSA/APS/SP)

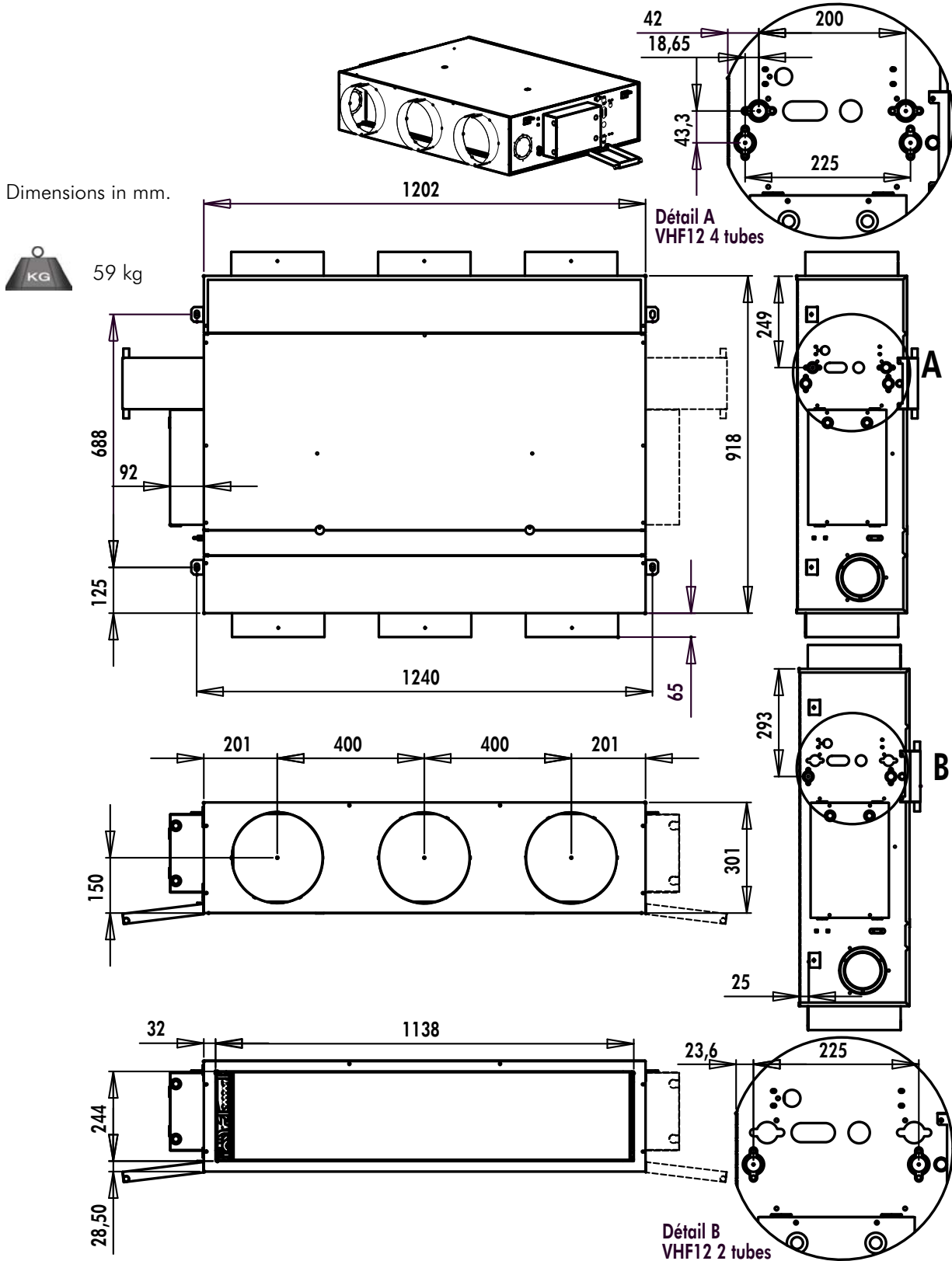

Note : The coil connections are of female threaded type $\varnothing 1/2"$.

Weight (VHF12 APSA) in functioning order, without valve, regulation and 5 rows coil.

5 - INSTALLATION

5.1 - UNIT HANDLING

Always take great care when handling the unit. **Do not lift the unit by the condensate outlet or by the water pipe connectors.** Use a fork lift truck to make it easier to install the unit.



Warning

Avoid contact with the coil surfaces and their sharp edges as they can be dangerous.

5.2 - LOCATION

1. The units are designed for installation above a suspended ceiling.
2. Install the unit in a location where the structure is capable of withstanding the weight of the unit.
3. Install the unit in a location which enable the unit's aeraulic inlet and outlet connections to be made.

Minimum free clearance for maintenance

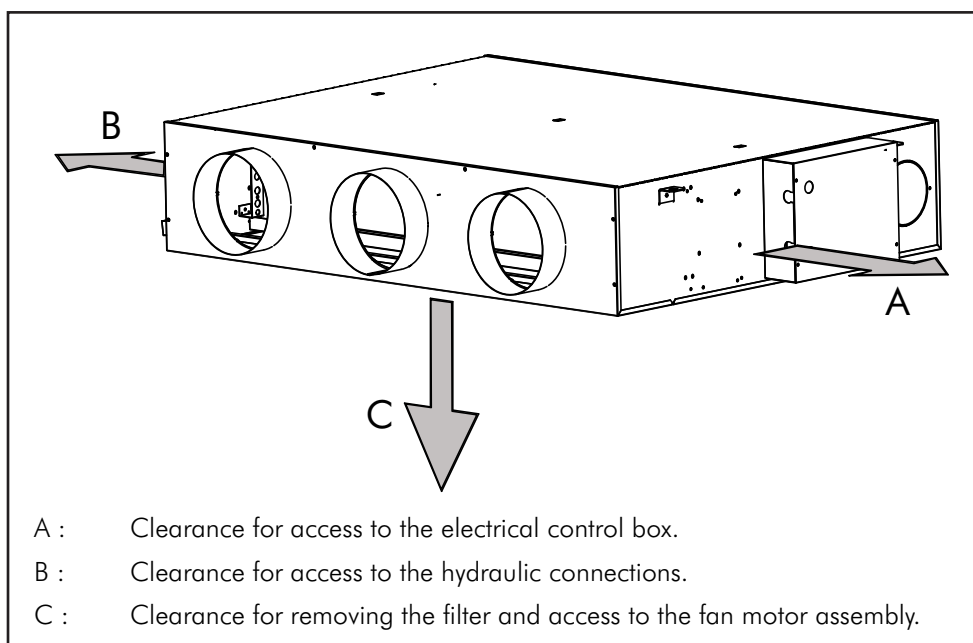

	VHF 01	VHF 05	VHF 10	VHF 12
A	300 mm			
B	500 mm			
C	250 mm	300 mm	350 mm	

4. Install the unit in a location providing for easy condensate evacuation.
5. Ensure that there is sufficient free space between the suspended ceiling and the solid ceiling for the unit to be located.
6. Take care to leave adequate space around the unit for maintenance access (refer to the illustration below for minimum free space on the service elevation for access to the filter and the fan motor assembly).



Warning

Do not install the unit in a machinery room or a kitchen where vapours or oil mist could pass through the unit.



Warning

Do not install the unit in a laundry or in very damp areas (bathroom, sauna, etc.).

5 - INSTALLATION (CONTINUED)

5.3 - INSTALLATION INSTRUCTIONS

1. The unit is designed to be suspended on threaded rods or screw-spikes to be supplied by the installer. The mounting lugs with slot type holes are fitted to the upper part of the unit.
2. Attach the 4 threaded rods or spike-screws to the solid ceiling in accordance with the diagram opposite. Place 4 nuts and washers on each threaded rod.
3. Lift up the unit and slide the 4 threaded rods through the mounting lugs slots (the unit casing must not touch the ceiling).
4. Attach the unit with 4 further firmly tightened washers, nuts and lock nuts. We recommend fitting rubber blocks to prevent any risks of vibration be transmitted to the structure.
5. Lock the unit in its final location and **level it off with a spirit level** in order to guarantee correct operation and condensate evacuation.
6. The unit must be installed so that the water drains towards the evacuation connection.

Mounting lugs

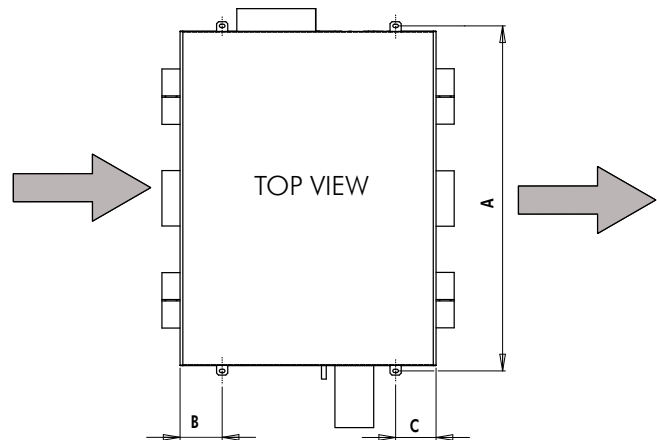

Sizes	VHF 01	VHF 05	VHF 10	VHF 12
A (mm)	640	1100	1240	
B (mm)	96	151		125
C (mm)	72	145		105

6 - HYDRAULIC CONNECTIONS

6.1 - COIL WATER CONNECTIONS

The units are equipped, in their standard 2-pipe configuration, with a main chilled water coil with 4 rows and 5 rows for VHF 12.

In the 4-pipe configuration, the unit is equipped, in the same finned block, with a 3 rows or 4 rows (VHF 12) chilled water coil and an additional 1 row for the heating function (on an independent circuit).

All the coils are fitted with headers with 1/2" gas threaded brass female unions.

The coil headers are equipped with air vent and drain plug. To vent the air from the coil, use the air vent located on the upper part of the upper header. To drain the water, use the drain plug located on the lower part of the lower header. The coil(s) **MUST** be drained of fluid in the event of the unit being kept out of service in buildings subjected to negative ambient temperatures with the possibility of the coil icing.



Take care

The supply water (2-pipe and 4-pipe coils) should pass through the bottom header.

The coil(s) is/are equipped with bleed valves for this purpose. To drain the coil, use the bleed valves located on the lower part of the lower collector.*

Flexible pipes are recommended for connecting the coils. Take care not to over-tighten the water connections. Over-tightening can lead to excessive strains on the materials in the event of major temperature variations.

All the water pipes must be insulated to avoid sweating and heat loss.



Take care

* The 3 or 4 lower pipes located at the level of the collector cannot be drained. However, the hydraulic connections on the lower part of the coil should be vented to the atmosphere by disconnecting all connectors, valves and pipes from the main hydraulic circuit.

6 - HYDRAULIC CONNECTIONS (CONTINUED)

⚠ Take care

For 4-pipe fan coil units with a hydraulic connection left side, the hot coil is located after the cold coil, in relation to the direction of the air (except for the VHF01).

However, if a right hand hydraulic connection is selected, the hot coil is then located before the cold coil.

⚠ Take care

To avoid damaging the coil, tighten the water pipe connectors on each header using a counter-wrench.

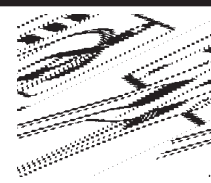

⚠ Take care

When installing the unit, take care not to push the coils headers towards the inside of the unit when tightening the connections.

6.2 - COIL WATER VOLUME

Sizes	Water volume (in liters)		
	2-pipe	4-pipe	
		Cooling	Heating
VHF 01	0,9	0,8	0,2
VHF 05	1,9	1,6	0,5
VHF 10	2,3	1,9	0,6
VHF 12	4.2	3.2	1,1

Note : The 2-pipe system is equipped with a 4 row or 5 row for VHF 12 coil whereas the 4-pipe system is equipped with 3 row or 4 row for VHF 12 and 1 row coils.

6.3 - CONDENSATE DRAIN CONNECTION

A condensate tray is supplied with a 7/8" exterior diameter copper drain hole.

Ensure that the condensed water will drain properly from the tray, which must be connected to the main evacuation pipe.

The evacuation pipe must be installed with a downhill angle. Check that the evacuation pipe work has a siphon which must be made in accordance with the illustration below. Moreover, the evacuation pipe must be insulated to prevent condensation forming on the outside of the pipe.

⚠ Take care

Check that there is no uphill section in the pipe run which might prevent condensate evacuation.

⚠ Warning

All foreign bodies must be removed from the condensate tray.

Siphon for condensate evacuation

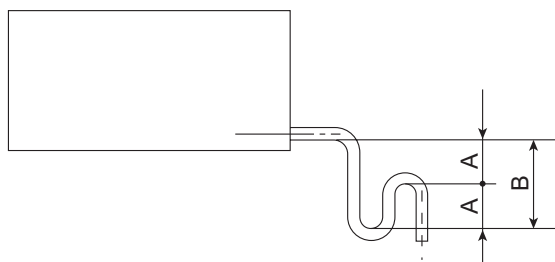

The height A must be equal to **2 times** the value of the negative pressure present in the condensate reception zone

Example : negative pressure = 40 mm, height A = 80 mm, height B = 160 mm).

6 - HYDRAULIC CONNECTIONS (CONTINUED)

6.4 - INSTALLATION OF THERMOSTAT OR TEMPERATURE SENSOR (CHANGE OVER)

TRM-FA or TRM-VP

The thermostat (change-over switch) supplied is to be mounted on the water supply pipe.

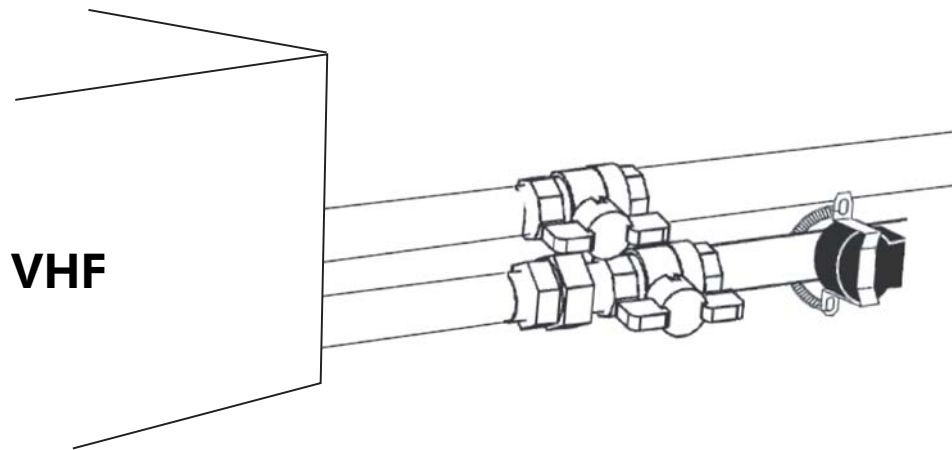

TAE20 or AQUANET

The temperature sensor (change over) supplied is to be fitted to the water inlet tube.

Before assembling the change over sensor, coat the tube with heat conducting paste to guarantee that the real temperature is recorded.

The M and B2 change over sensor inputs can be connected to the mains power supply. If it is necessary to extend the sensor wires, ensure that wires appropriate for this voltage are used.

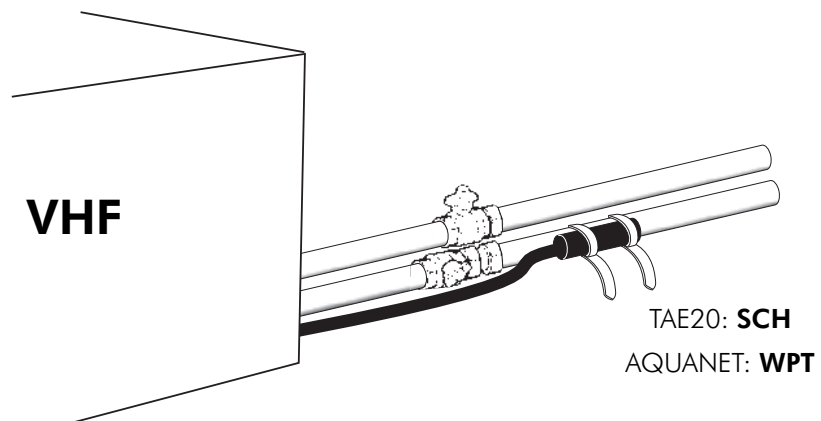

7 - ELECTRICAL CONNECTIONS

7.1 - UNIT CONNECTIONS

All units are intended to be connected to a 230 V \pm 10 % - 1 Ph - 50 Hz + Earth power supply network. For electrical heaters of a capacity greater than 3000W, a power supply of 400V – 3 Ph – 50 Hz + neutral + Earth is required.

Before starting any electrical connection, check information given on the fan motor label. All units are fitted with terminals.

Connection to the electrical network must comply with current electrical standards.

7.2 - REGULATION

As standard, the units are supplied without regulation equipment.

However, certain control devices (fan speed selector, remote thermostat, etc.) can be supplied according to request.

In all events, these regulation devices are only intended to control **a single unit**.

7.3 - ELECTRIC HEATING RESISTANCES

Factory mounted electrical heaters incorporate a self-resetting thermal cut-out and a non-self-resetting thermal cut-out which cut the power supply to the heaters in the event of an abnormal airflow reduction.

The wiring diagram affixed to the unit illustrates the connections to be made.

7.4 - WIRING DIAGRAM



Take care

The unit must be earthed.

The manufacturer and their representatives decline all responsibility for any accidents caused by inadequate or non-existent earthing of the installation.



Take care

Do not connect several units to a single ventilation speed selector or regulation thermostat without using auxiliary relays.

Check that the current absorbed by the motors and the electrical heaters is compatible with the cut-out capacity of the control device contacts.



Take care

The electric heating resistances must never operate without ventilation.

SEE APPENDIX

8 - AERAILIC CONNECTIONS

Only the supply air plenum is insulated. In option the plenum of aspiration can be isolated (in standard for the VHF01).

The return air plenum is fitted with a pre-cut inlet for fresh air intake:

Ø100mm (VHF 01)

Ø100mm or 125mm (VHF05 - VHF10 - VHF12).



Warning

In no event should one or more of the apertures be blocked.

If one of these apertures were to be blocked, it would create a drop in unit available static pressure, and poor air irrigation on the coil surface, leading to a significant drop in unit performance and possible fan motor damage.

OBLONG PLENUM equivalent Ø250

VHF 05

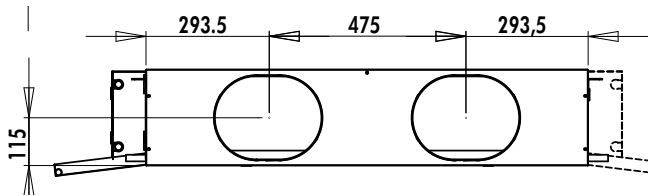

VHF 10

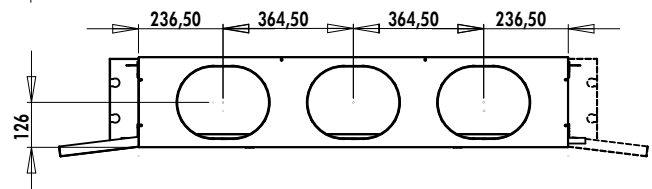

PLENUM Ø 160

VHF 01

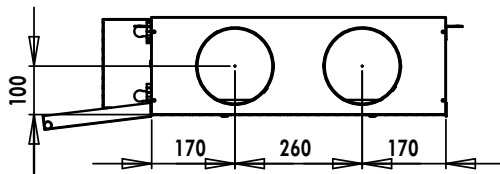

PLENUM Ø 200

VHF 05

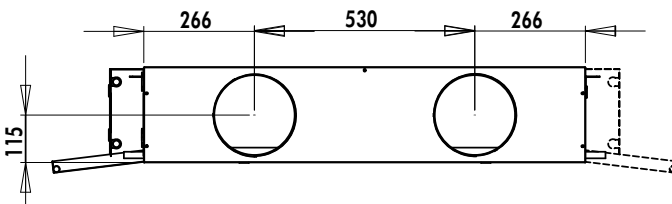

VHF 10

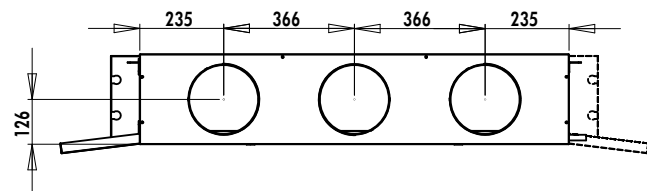

Dimensions in mm.

8 - AERUALIC CONNECTIONS (CONTINUED)

PLENUM Ø 250

VHF 12

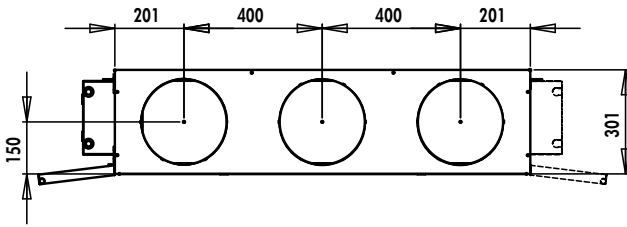

VHF 10

VHF 01

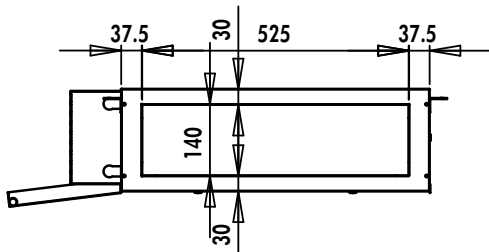

VHF 05

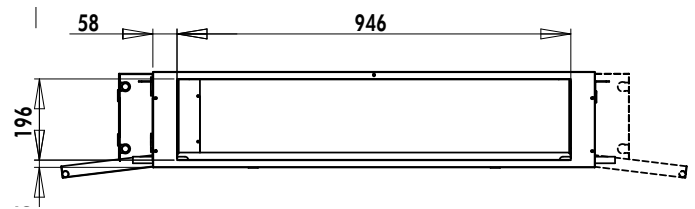

RECTANGULAR PLENUM

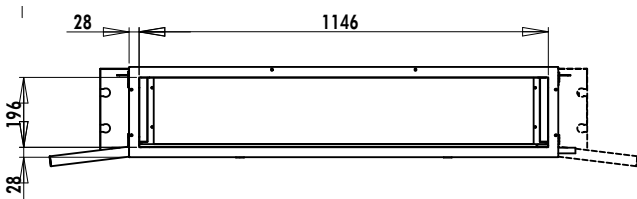

VHF 12

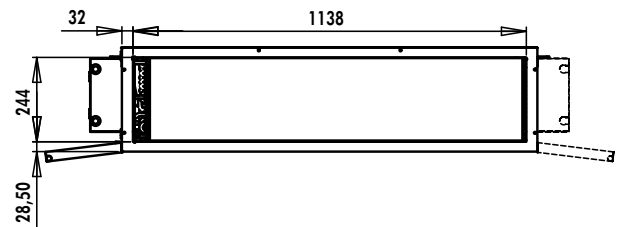

FRESH AIR INTAKE

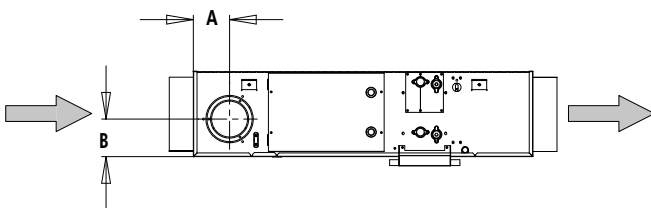

Sizes	VHF 01	VHF 05	VHF 10	VHF 12
A (mm)	64	98	98	98
B (mm)	77	102	123	127

Dimensions in mm.

9 - PRELIMINARY CHECKS BEFORE COMMISSIONING

1. Check that the system pipe work has been cleaned and that all the air has been bled from the system before starting the unit.
2. Check that the condensate evacuation pipe is connected, and provides proper evacuation, and is connected to a siphon.
3. Check that the air filter is clean and correctly installed.
4. Check that the fan turns freely.
5. Check that all the electrical and water connections have been correctly tightened.

10 - OPERATION

The unit operates in different ways, depending of the control options that have been installed:

AQUANET

TRM-VP

TRM-FA

TAE 20

SEE APPENDIX

10.1 - AQUANET





SEE SPECIFIC MANUAL



10.2 - TRM-FA AND TRM-VP

On the remote control (illustrated below) the unit is controlled by :

- 1) An "I/O" On/Off switch ;
- 2) A manual selector for 3 speeds of ventilation indicated by a "Turbine" symbol :

-  low speed,
-  medium speed,
-  high speed ;

- 3) A thermostat for setting and maintaining the desired ambient temperature ;

- 4) A manual Summer / Winter changeover switch indicated by " and " symbol.

Cooling mode 

Heating mode 





TRM-FA and TRM-VP

10 - OPERATION (CONTINUED)

10.3 - TAE 20

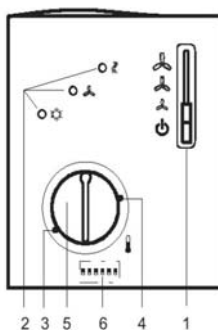
ADJUSTMENT AND CONTROL ELEMENTS



- 1 Operating mode switch (Standby , heating or cooling with manual fan speed selection).
- 2 Electro-luminescent diodes for displaying the heating and cooling modes and the fan.
- 3 Minimum temperature setting limiter (adjustable by increments of 1 K). Mechanical stop accessible by removing the button 5.
- 4 Maximum temperature setting limiter (adjustable by increments of 1 K). Mechanical stop accessible by removing the button 5.
- 5 Ambient temperature setting adjustment button.
- 6 Set of DIP switches (intern).

DIP switch ref. 6	Function N°	"ON" position	"OFF" position
1	Fan control	Fan control is temperature dependent in all modes	In normal mode, the fan control is independent of the temperature 1)
2	Mode changing via an external switch	Switching between normal mode and energy saving mode	Switching between normal mode and stand by 1)
3	Switch action direction for external mode switching	Switch activated when the switch is closed (N.O. «Normally open» 1)	Switching activated when the switch is open (N.C. «Normally close»)
4	Stand by	Antifreeze control deactivated	Antifreeze control activated 1)
5	Differential	1 K in heating mode ¹⁾ 0,5 K in cooling mode	4 K in heating mode 2 K in cooling mode
6	Neutral zone in normal mode	2 K 1)	5 K
7	Temperature setting variance	2 K 1)	4 K
8	Electric heating	Activated in cooling mode ¹⁾	Deactivated in cooling mode

¹⁾ Factory setting

11 - MAINTENANCE

To guarantee correct unit operation, the following maintenance operations are recommended.

Take care

Disconnect the power supply before undertaking any maintenance operations.

11.1 - AIR FILTER

The filters must be cleaned frequently in order to prevent clogging. They should be inspected every 3 or 4 months in normal operating conditions and replaced if necessary.

To remove the air filter, unscrew by halves the 2 fixing screws (C) and turn round the two washers to open the access panel (B).

Watch out, the air filter could possibly fall during opening of the access panel.

11.2 - CONDENSATE TRAY

The condensate tray must be checked regularly to ensure that the evacuation pipe is not blocked. If required, it can be cleaned and washed with water.

To remove the condensate tray :

- 1) Remove the filter access panel (B) as described above.
- 2) Unscrew and remove the bottom panel (screws D).

Watch out, the condensate drain pan could possibly fall during removing of the bottom panel.

11.3 - COILS

Check that the fins are not clogged or damaged.

To avoid the coils becoming mouldy with an accumulation of tiny impurities, it is recommended that they are cleaned regularly. If necessary, brush the coils with an appropriate tool.

Take care not to damage the fins during cleaning.

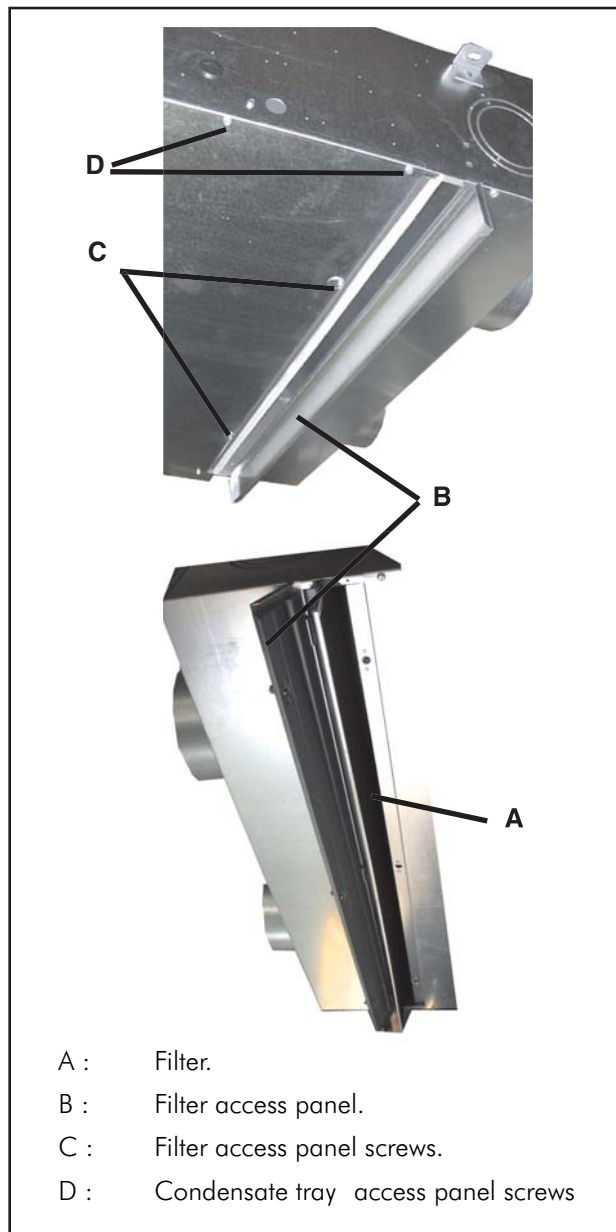

11 - MAINTENANCE (CONTINUED)

11.4 - FAN MOTOR ASSEMBLY

The fan motor assembly does not require any particular maintenance. The motors are equipped with sliding bearing. Adding oil is not necessary. However, each time regular maintenance is performed, the fan should be inspected to check that it turns freely without friction.

In the event of the fan motor overload protection device engaging, wait for the automatic protection to reset itself and seek out the cause of the protection device being triggered.

To remove the fan motor assembly :

- Open the trap door of access to the filter and to withdraw the lower central panel.
- Disconnect the fan motor assembly power supply starting from the electric box.
- Unscrew the 4 fan motor assembly retaining screws (2 on each side of the unit).

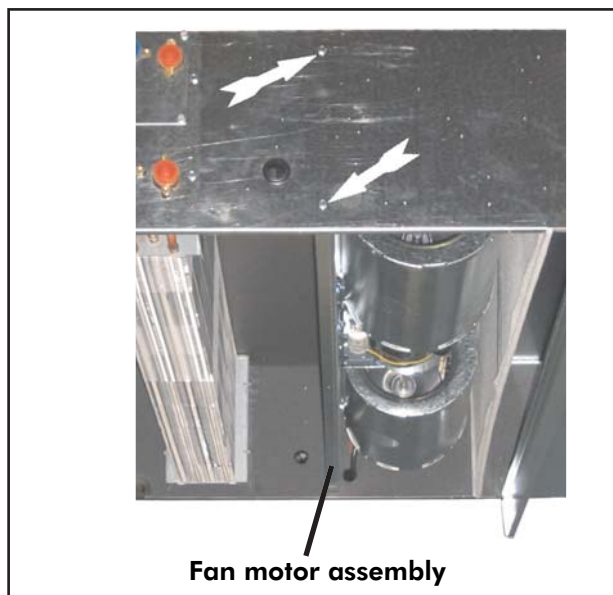

11.5 - ELECTRICAL CONNECTIONS

Periodically retighten the electrical connections.

11.6 - WATER PIPES

Once a year, drain the water pipes and check for scale formation. De-scale the pipes if required.

Take care

If the water pipes are exposed to temperatures below 0 °C, take the necessary precautions (draining, antifreeze, etc.) to avoid the coils freezing. Adding antifreeze to the circuit reduces the unit's performance (if necessary, please contact our sales network).

Take care

It is not the manufacturer's policy to make recommendations in terms of water treatment (please contact a specialised water treatment company).

However, given the critical nature of this subject, particular care should be taken to ensure that, if treatment is required, it works effectively.

Using untreated or unsuitable water leads to excessive clogging inside the coil tubes (earth and mud deposits, corrosion, etc.) with major consequences on the thermal efficiency of the unit and irreversible damage to the equipment.

The manufacturer and its representative decline all responsibility in the event of untreated or incorrectly treated water being used.

12 - IN-WARRANTY RETURN MATERIAL PROCEDURE

Material must not be returned without permission of our After Sales Department.

To return the material, contact your nearest sales office and ask for a "return voucher". This return voucher shall be sent out with the returned material and shall contain all necessary information concerning the problem encountered.

The return of the part does not constitute an order for replacement. Therefore, a purchase order must be entered through your nearest distributor or regional sales office. The order should include part name, part number, model number and serial number of the unit involved.

Following our personal inspection of the returned part, and if it is determined that the failure is due to faulty material or workmanship, and in warranty, credit will be issued on customer's purchase order. All parts shall be returned to our factory, transportation **charges prepaid**.

13 - SERVICE AND SPARE PARTS ORDER

The model number, the confirmation number and the unit serial number indicated on the name plate must be provided whenever service works or spare parts are ordered.

For any spare part order, indicate the date of unit installation and date of failure. Use the part number provided by our service spare parts, if it not available, provide full description of the part required.

APPENDIX
ANNEXE
ANLAGE
ALLEGATO
ANEXO

APPENDIX

PRINCIPAL WIRING DIAGRAM.....III

ANNEXE

SCHEMAS ELECTRIQUES PRINCIPAUXIII

ANLAGE

STROMLAUFPLANS WICHTIGIII

ALLEGATO

SCHEMAS ELETRICI PRINCIPALI.....III

ANEXO

ESQUEMAS ELÉCTRICOS PRINCIPALES.....III

PRINCIPAL WIRING DIAGRAM

SCHEMAS ELECTRIQUES PRINCIPAUX

STROMLAUFPLANS WICHTIG

SCHEMAS ELETRICI PRINCIPALI

ESQUEMAS ELÉCTRICOS PRINCIPALES

TAKE CARE!

These wiring diagrams are correct at the time of publication. Manufacturing changes can lead to modifications. Always refer to the diagram supplied with the product.

ATTENTION

Ces schémas sont corrects au moment de la publication. Les variantes en fabrication peuvent entraîner des modifications. Reportez-vous toujours au schéma livré avec le produit.

ACHTUNG!

Diese Stromlaufplans sind zum Zeitpunkt der Veröffentlichung gültig. In Herstellung befindliche Varianten können Änderungen mit sich bringen. In jedem Fall den mit dem Produkt gelieferten Stromlaufplan hinzuziehen.

ATTENZIONE !

Questi schemi sono corretti al momento della pubblicazione. Le varianti apportate nel corso della fabbricazione possono comportare modifiche. Far sempre riferimento allo schema fornito con il prodotto.

ATENCIÓN !

Esto esquemas son correctos en el momento de la publicación. Pero las variantes en la fabricación pueden ser motivo de modificaciones. Remítase siempre al esquema entregado con el producto.

POWER SUPPLY MUST BE SWITCHED OFF BEFORE STARTING TO WORK IN THE ELECTRIC CONTROL BOXES!



MISE HORS TENSION OBLIGATOIRE AVANT TOUTE INTERVENTION DANS LES BOITIERS ELECTRIQUES.

VOR JEDEM EINGRIFF AN DEN ANSCHLUßKÄSTEN UNBEDINGT DAS GERÄT ABSCHALTEN!

PRIMA DI OGNI INTERVENTO SULLE CASSETTE ELETTRICHE ESCLUDERE TASSATIVAMENTE L'ALIMENTAZIONE !

PUESTA FUERA DE TNESIÓN OBLIGATORIA ANTES DE CUALQUIER INTERVENCIÓN EN LAS CAJAS ELÉCTRICAS!

2T

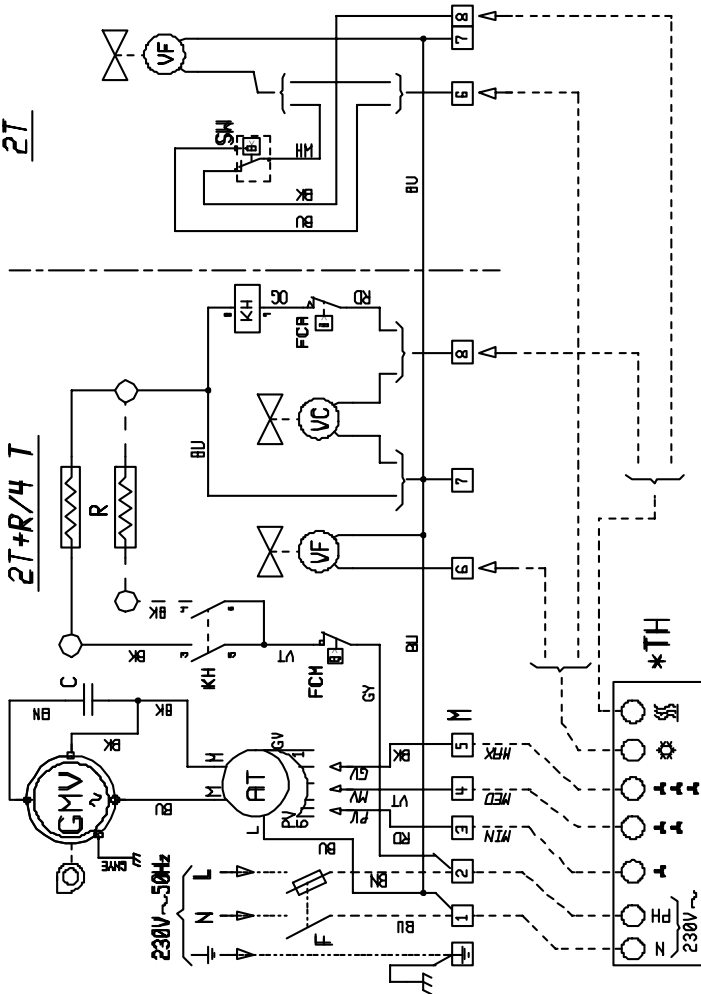

VHF Ø1/VH2N Ø3 STANDARD

- GMV GROUPE MOTEUR VENTILATEUR
- C CONDENSATEUR
- AT AUTOTRANSFORMATEUR
- PV PETITE VITESSE
- MV MOYENNE VITESSE
- GV GRANDE VITESSE
- M BORNIER DE RACCORDEMENT

OPTIONS

- KH RELAIS CHAUFFAGE ELECTRIQUE
- R ELEMENT(S) CHAUFFANT(S)
- FCA SECURITE AUTOMATIQUE
- FCH SECURITE MANUELLE
- VF SERVOMOTEUR-EAU FROIDE
- VC SERVOMOTEUR-EAU CHAUDE (4 tubes)
- F PROTECTION GENERALE
- SH THERMOSTAT CHANGE-OVER

VERDE/RM.	VERT./R.	GRUN/G.
VIOLET	PURPLE	VIOLETT
BLAU	BLUE	AZUL
ROT	RED	ROJO
SCHWARZ	BLACK	NERO
GRUN/YELL.	VERT./Y.	GRUN/G.
GIALLO/V.	PURPLE	VIOLETT
	BLAU	AZUL
	ROT	ROJO
	ROSSO	
	NEGRO	

- GMV FAN MOTOR
- C CONDENSATOR
- AT AUTO TRANSFORMER
- PV LOW SPEED
- MV MEDIUM SPEED
- GV HIGH SPEED
- M TERMINAL STRIP

OPTIONS

- KH ELECTRIC HEATING RELAY
- R ELECTRIC HEATER
- FCA AUTOMATIC THERMOSTAT
- FCH MANUAL THERMOSTAT
- VF COOLING VALVE
- VC HEATING VALVE (4 pipes)
- SH CHANGE-OVER THERMOSTAT
- F GENERAL PROTECTION

- GMV GROUPE MOTO VENTILATOR
- C CONDENSATORE
- AT AUTO TRANSFORMATORE
- PV VELOCITA MINIMA
- MV VELOCITA MEDIA
- GV VELOCITA MASSIMA
- M MORSETTI SCATOLA ELECT.

OPZIONI

- KH RELE RISCALDAMENTO ELETTRICO
- R RESIST. RISCALDAMENTO
- FCA THERMOSTATO AUTOMATICA
- FCH THERMOSTATO MANUALE
- VF VALVOLA ESTATE
- VC VALVOLA INVERNO (4 tubi)
- SH THERMOSTATO CHANGE-OVER
- F GENERAL PROTECTION

- GMV MOTOR VENTILACION
- C CONDENSADOR
- AT AUTO TRANSFORMADOR
- PV BAJA VELOCIDAD
- MV MEDIANA VELOCIDAD
- GV ALTA VELOCIDAD
- M BORNERA DE CONEXION

OPCIONES

- KH RELE CALEFACCION ELECTRICO
- R RESISTANCIA CALEFACCION
- FCA THERMOSTATO AUTO.
- FCH SEGURIDAD MANUAL
- VF VALVULA FRIO
- VC VALVULA CALD (4 tubos)
- SH THERMOSTATO CHANGE-OVER
- F GENERAL PROTECTION

- GMV VENTILATORMOTOREINHEIT
- C KONDENSATOR
- AT AUTO TRANSFORMATOR
- PV NIEDRIGE DREHZAHL
- MV MITTLERE DREHZAHL
- GV HOCH DREHZAHL
- M KLEMMLEISTE

OPTIONEN

- KH RELAIS ELEKTROHEIZUNG
- R HEIZUNGSWIDERSTAND
- FCA UBERHEIZUNGSSCHUTZ
- FCH HANDBERHEIZUNGSSCHUTZ
- VF KALTWASSERSCHIEBER
- VC WARMWASSERSCHIEBER (4 rohren)
- SH THERMOSTATE CHANGE-OVER
- F GENERAL PROTECTION

***TH**
 vers thermostat
 to thermostat
 verso termostato
 hacia termostato
 in richtung des
 thermostat

CODE : 399842

230V ~	50 Hz
SE 3404 B	

VHF 05-10-12 STANDARD
VH2N 05-07-10 STANDARD

GMV GROUPE MOTEUR VENTILATEUR
 VI à V6 PETITE à GRANDE VITESSE
 M BORNIER DE RACCORDEMENT

OPTIONS

KH RELAIS CHAUFFAGE
 R ELEMENT(S) CHAUFFANT(S)
 FCM SECURITE MANUELLE
 FCA SECURITE AUTOMATIQUE
 VF VANNE FROID
 VC VANNE CHAUD (4 tubes)
 SH THERMOSTAT CHANGE-OVER
 F PROTECTION GENERALE

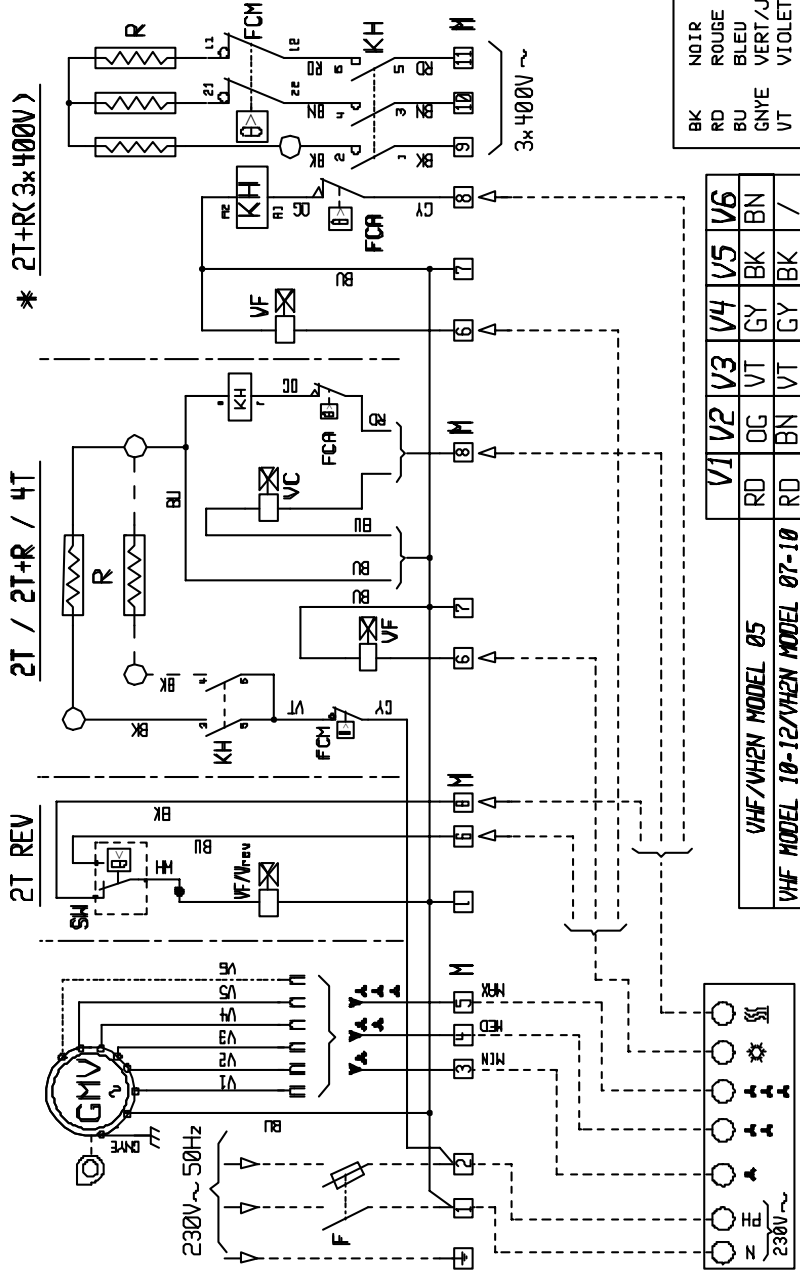

BK	NOIR	BLACK	NEGRD	SCHWARTZ	NERD
RD	ROUGE	RED	ROSSD	ROT	ROJUD
BLU	BLEU	BLUE	BLU	BLAU	AZUL
GYE	VERT./JA.	GREEN/YELL.	GIALLO/V.	GRUN/G.	VERDE/AM.
VT	VIOLET	PURPLE	VIOLA	VIOLETT	VIOLETA

V1	V2	V3	V4	V5	V6
RD	OG	VT	GY	BK	BN
RD	BN	VT	GY	BK	/

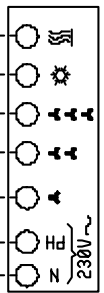

POUR VHF
 FOR VHF
 PER VHF
 PARA VHF
 FÜR VHF

GMV VENTILATORMOTOREINHEIT
 VI-V6 NIEDRIGE-HOCH DREHZAHL
 M KLEMMLEISTE

GMV MOTOR VENTILACION
 VI-V6 BAJA-ALTA VELOCIDAD
 M BORNERA DE CONEXION

GMV GROUPE MOTO VENTILATOR
 VI-V6 MINIMA-MASSIMA VELOCITA
 M MORSETTI SCATOLA ELECT.

GMV FAN MOTOR
 VI-V6 LOW-MAX SPEED
 M TERMINAL STRIP

OPZIONEN

KH RELAIS ELEKTROHEIZUNG
 R HEIZUNGWIDERSTAND
 FCM HANDBERHITZUNGSSCHUTZ
 VF KALTWASSERSCHIEBER
 VC WARMWASSERSCHIEBER (4 röhren)
 SH THERMOSTATE CHANGE-OVER
 F ALLGEMEINER SCHUTZ

OPCIONES

KH RELE CALEFACCION ELECTRICO
 R RESISTANCIA CALEFACCION
 FCA TERMOSTATO AUTO
 FCH SEGURIDAD MANUAL
 VF VALVULA FRIO
 VC VALVULA CALO (4 tubos)
 SH THERMOSTATO CHANGE-OVER
 F PROTECCION GENERAL

OPZIONI

KH RELE RISCALDAMENTO ELETTRICO
 R RESIST. RISCALDAMENTO
 FCA TERMOSTATO AUTOMATICA
 FCH SICUREZZA MANUALE
 VF VALVOLA ESTATE
 VC VALVOLA INVERNO (4 tubi)
 SH THERMOSTATO CHANGE-OVER
 F PROTEZIONE GENERALE





OPTIONS



KH ELECTRIC HEATING RELAY
 R ELECTRIC HEATER
 FCM MANUAL THERMOSTAT
 FCA AUTO THERMOSTAT
 VF COOLING VALVE
 VC HEATING VALVE (4 pipes)
 SH CHANGE-OVER THERMOSTAT
 F GENERAL PROTECTION

CODE : 300707

230V/400V	50 Hz
SE 3267 D	

APPENDIX / ANNEXE / ANLAGE / ALLEGATO / ANEXO

	2T	4T					
GB	2-PIPE COILS	4-PIPE COILS	COOLING	HEATING	LOW SPEED	MEDIUM SPEED	HIGH SPEED
F	BATTERIES 2 TUBES	BATTERIES 4 TUBES	FROID	CHAUD	PETITE VITESSE	VITESSE MOYENNE	GRANDE VITESSE
D	BATTERIEN 2 ROHREN	BATTERIEN 4 ROHREN	KÜHLUNG	HEIZUNG	KLEINE GESCHWINDIGKEIT	MITTLERE GESCHWINDIGKEIT	HOHE GESCHWINDIGKEIT
I	BATTERIE 2 TUBI	BATTERIE 4 TUBI	FREDDO	RISCALDO	BASSA VELOCITÀ	VELOCITÀ MEDIA	ALTA VELOCITÀ
E	BATERÍAS 2 TUBOS	BATERÍAS 4 TUBOS	FRIO	CALOR	VELOCIDAD BAJA	VELOCIDAD MEDIA	VELOCIDAD ALTA

			SCH	SW
GB	ELECTRIC HEATING	CONTROL VALVE	CHANGE OVER (TAE 20)	CHANGE OVER (TRM-FA TRM-VP)
F	CHAUFFAGE ELECTRIQUE	VANNE DE REGULATION	CHANGE OVER (TAE 20)	CHANGE OVER (TRM-FA TRM-VP)
D	ELEKTROHEIZUNG	REGELVENTIL	CHANGE OVER (TAE 20)	CHANGE OVER (TRM-FA TRM-VP)
I	RISCALDAMENTO ELETRICO	VALVOLA DI REGOLAZIONE	CHANGE OVER (TAE 20)	CHANGE OVER (TRM-FA TRM-VP)
E	CALEFACCION ELECTRICA	VÁLVULA REGULADORA	CHANGE OVER (TAE 20)	CHANGE OVER (TRM-FA TRM-VP)

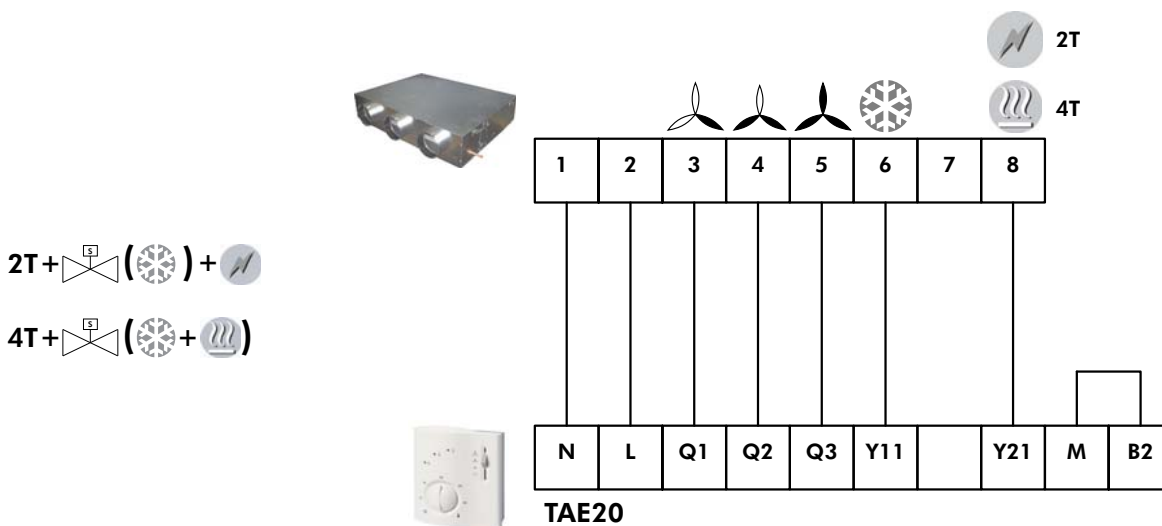
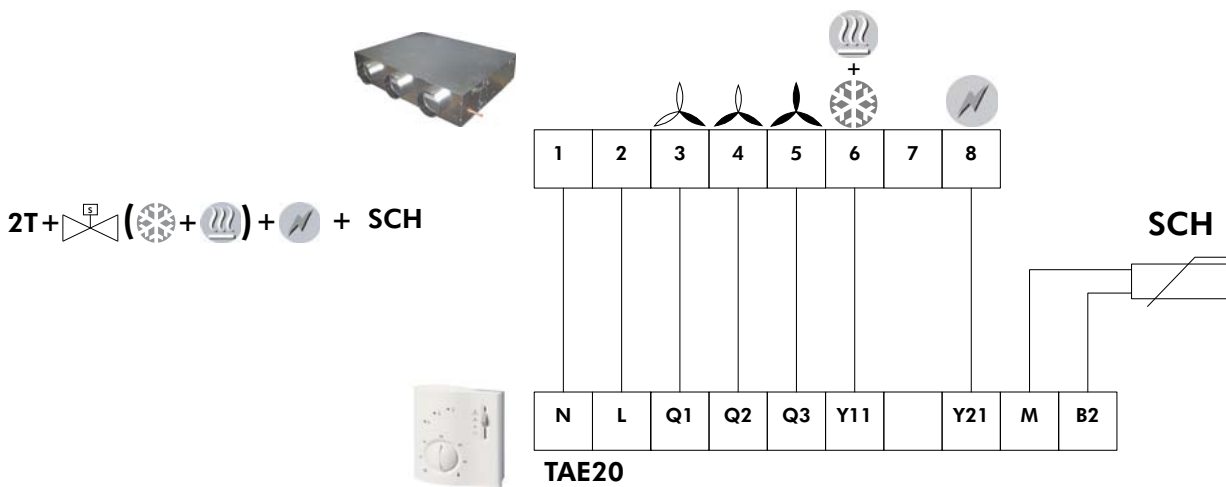

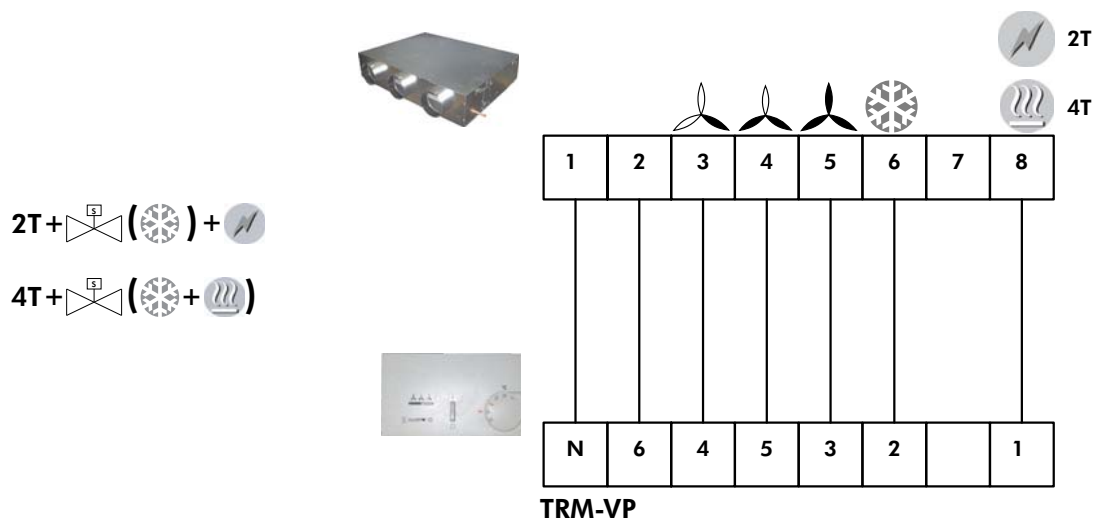
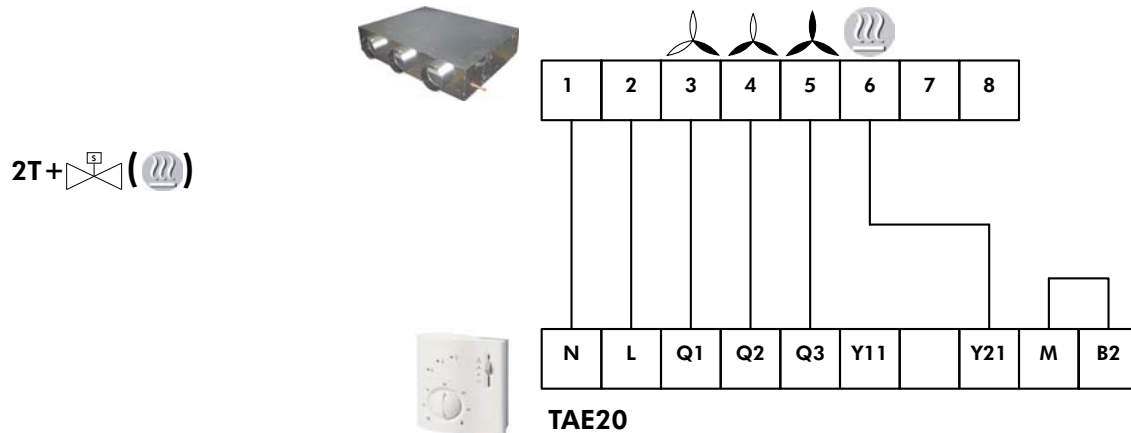
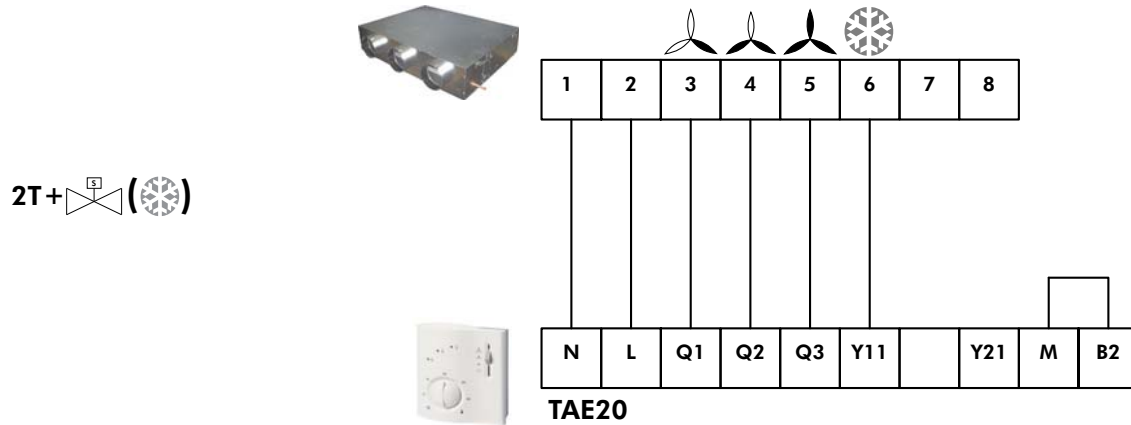
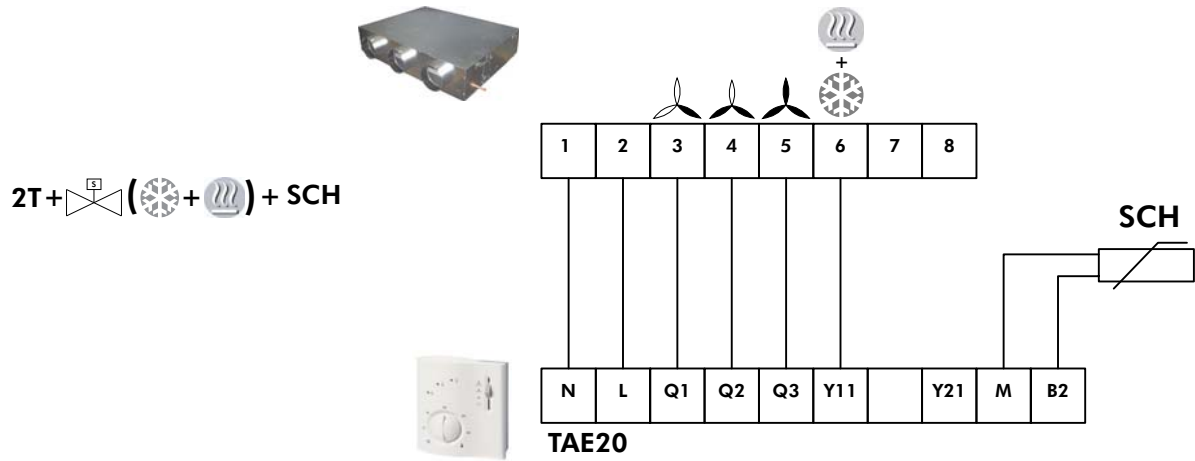

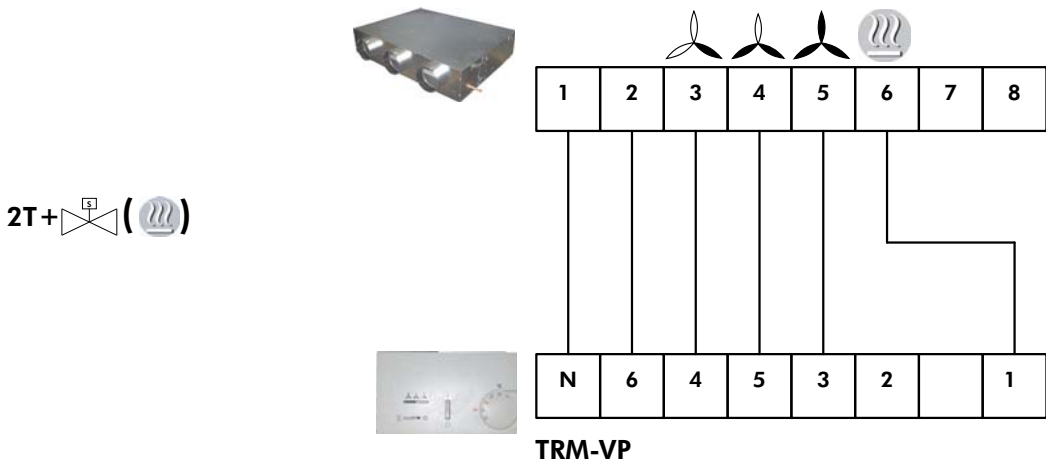
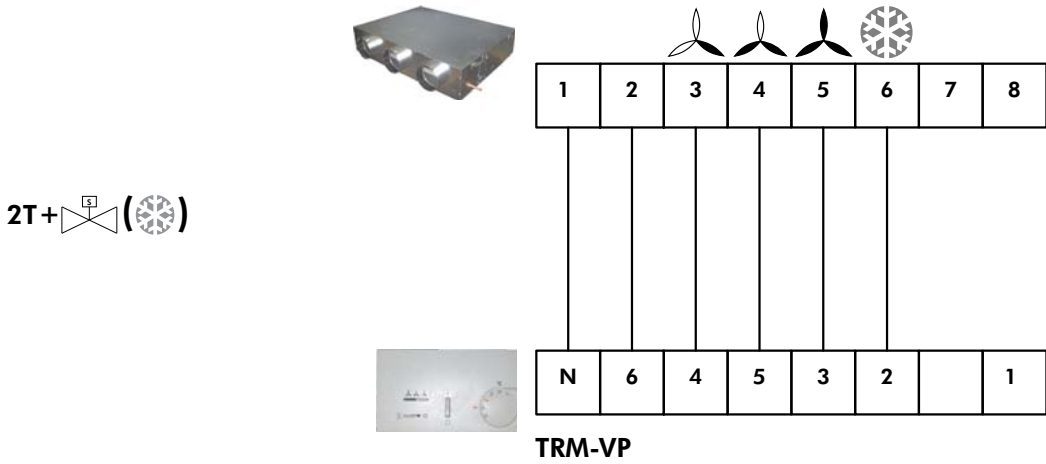
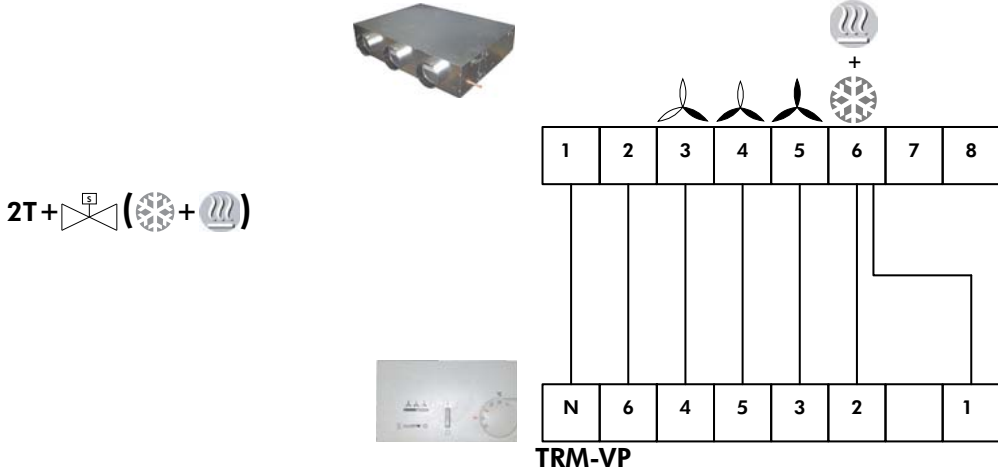
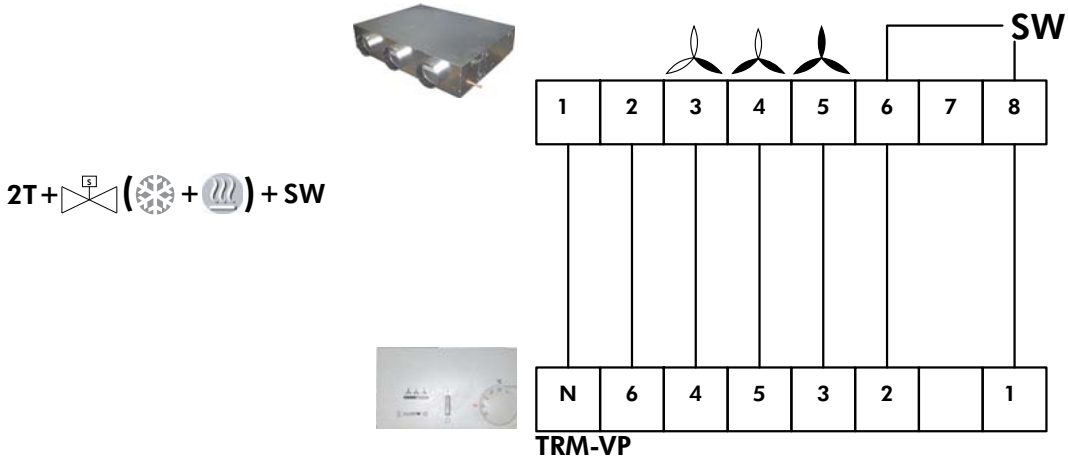

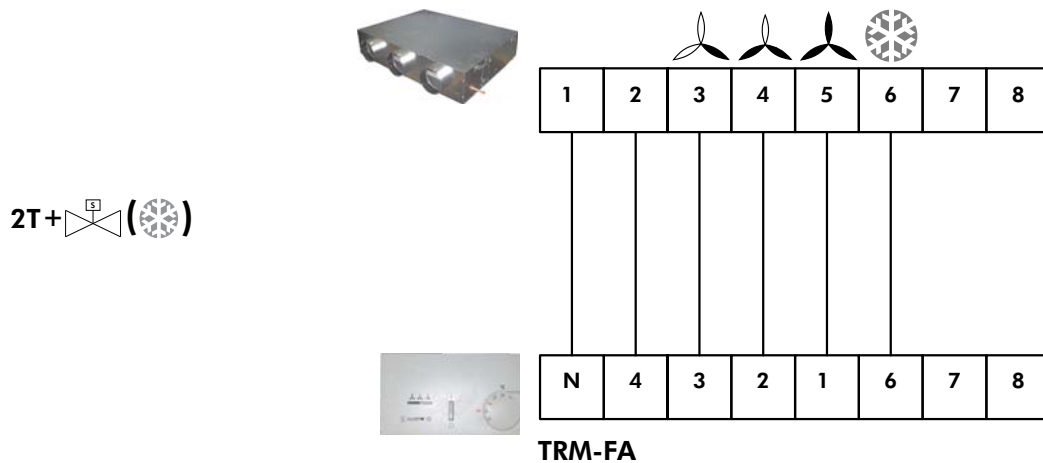
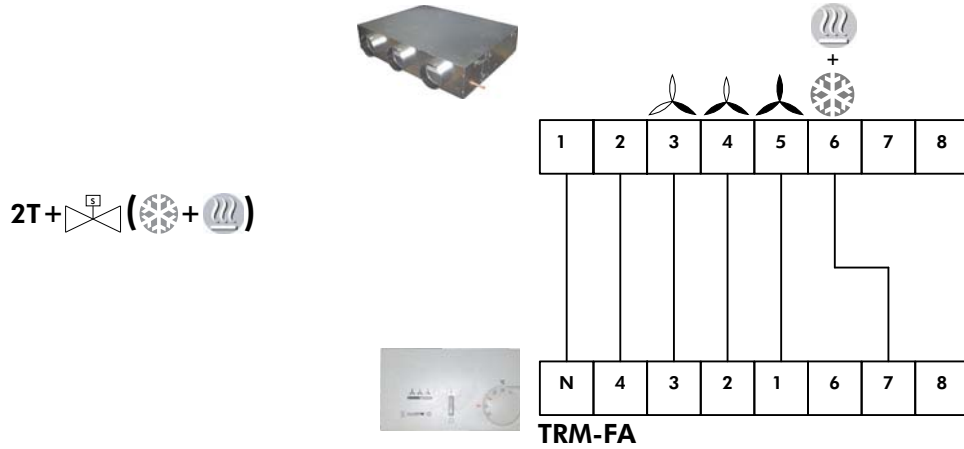
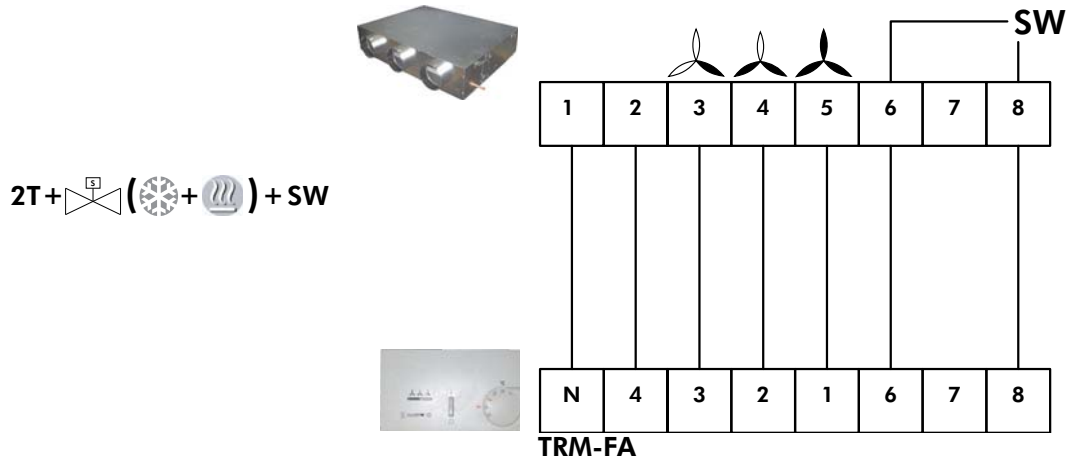
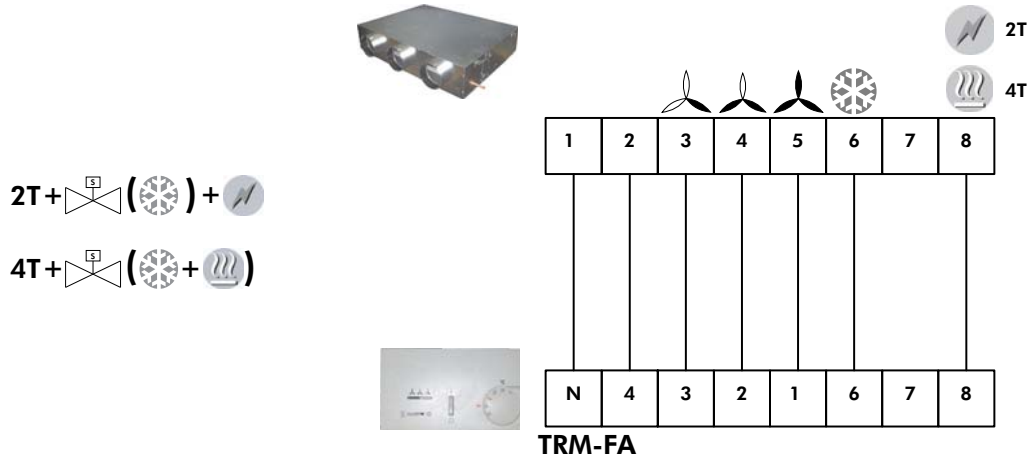

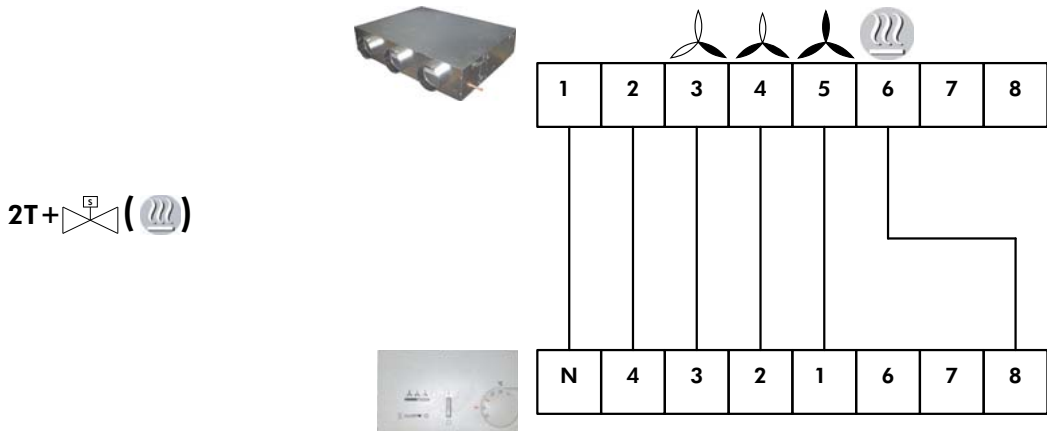

TRM-FA

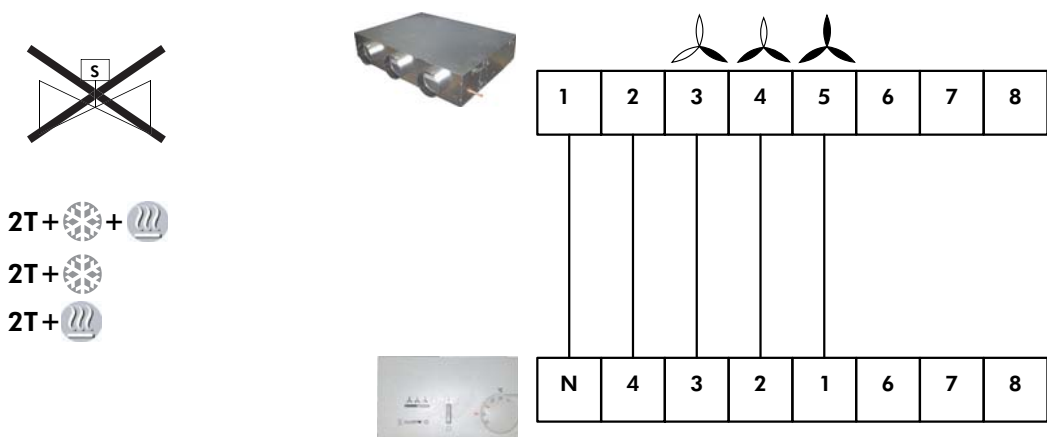

TRM-FA

CE Compliance declaration

Under our own responsibility, we declare that the product designated in this manual comply with the provisions of the EEC directives listed hereafter and with the national legislation into which these directives have been transposed.

Déclaration CE de conformité

Nous déclarons sous notre responsabilité que les produits désignés dans la présente notice sont conformes aux dispositions des directives CEE énoncées ci-après et aux législations nationales les transposant.

EG-Konformitätserklärung

Wir erklären in eigener Verantwortung, das die in der vorliegenden Beschreibung angegebenen Produkte den Bestimmungen der nachstehend erwähnten EG-Richtlinien und den nationalen Gesetzesvorschriften entsprechen, in denen diese Richtlinien umgesetzt sind.

Dichiarazione CE di conformità

Dichiariamo, assumendone la responsabilità, che i prodotti descritti nel presente manuale sono conformi alle disposizioni delle direttive CEE di cui sott e alle legislazioni nazionali che li recepiscono

Declaración CE de conformidad

Declaramos, bajo nuestra responsabilidad, que los productos designados en este manual son conformes a las disposiciones de las directivas CEE enunciadadas a continuación, así como a las legislaciones nacionales que las contemplan.

VHF 01 - 05 - 10 - 12
REF:

MACHINERY DIRECTIVE 98 / 37 / CEE
LOW VOLTAGE DIRECTIVE (DBT) 73 / 23 / CEE AMENDED BY DIRECTIVE 93 / 68 CEE
ELECTROMAGNETIC COMPATIBILITY DIRECTIVE 89 / 336 / CEE
PRESSURISE EQUIPMENT DIRECTIVE (DESP) 97 / 23 / CEE
SUB-MODULE A CATEGORY I

DIRECTIVE MACHINES 98 / 37 C.E.E.
DIRECTIVE BASSE TENSION (DBT) 73 / 23 C.E.E. , AMENDEE PAR DIRECTIVE 93 / 68 C.E.E.
DIRECTIVE COMPATIBILITE ELECTROMAGNETIQUE 89 / 336 / C.E.E.
DIRECTIVE DES EQUIPEMENTS SOUS PRESSION (DESP) 97 / 23 C.E.E.

MODULE **A** CATEGORIE **I**

RICHTLINIE MASCHINEN 98 / 37 / EG
RICHTLINIE NIEDERSpannung (DBT) 73 / 23 / EG ABGEÄNDERT DURCH DIE RICHTLINIE 93 / 68 EG
RICHTLINIE ELEKTROMAGNETISCHE VERTRÄGLICHKEIT 89 / 336 / EG
RICHTLINIE FÜR AUSTRÜSTUNGEN UNTER DRUCK (DESP) 97 / 23 / EG

UNTER MODUL **A**, KATEGORIE **I**

DIRETTIVA MACHINE 98 / 37 / CEE
DIRETTIVA BASSA TENSIONE (DBT) 73 / 23 / CEE EMENDATA DALLA DIRETTIVA 93 / 68 CEE
DIRETTIVA COMPATIBILITA ELETTROMAGNETICA 89 / 336 / CEE
DIRETTIVA DEGLI IMPIANTI SOTTO PRESSIONE (DESP) 97 / 23 / CEE

SOTTOMODULO **A**, CATEGORIA **I**

DIRETTIVA MAQUIAS 98 / 37 / CEE
DIRECTIVA BAJA TENSION (DBT) 73 / 23 / CEE ENMENDATA POR LA DIRECTIVA 93/ 68 CEE
DIRECTIVA COMPATIBILIDAD ELECTROMAGNETICA 89 / 336 / CEE
DIRECTIVA DE LOS EQUIPOS A PRESION (DESP) 97 / 23 / CEE

BAJA MODULO **A**, CATEGORIA **I**

And that the following paragraphs of the harmonised standards have been applied.
Et que les paragraphes suivants les normes harmonisées ont été appliqués.
Und dass die folgenden Paragraphen der vereinheitlichten Normen Angewandt wurden.
E che sono stati applicati i seguenti paragrafi delle norme armonizzate.
Y que se han aplicado los siguientes apartados de las normas armonizadas.

EN 60 204-1
EN 55 014-1
EN 378

EN 60 335-1
EN 50 014-2
EN 255

EN 60 335-2-40
EN 814

A Tillières Sur Avre
27570 - FRANCE
Le: 19/05/2004
Franck Bailly
Responsable Qualité

*As part of our ongoing product improvement programme, our products are subject to change without prior notice. Non contractual photos.
Dans un souci d'amélioration constante, nos produits peuvent être modifiés sans préavis. Photos non contractuelles.*

