





















Transfer



Lindab	1
General information and theory	2
Safe	3
Silencers	4
Dampers & Measure units	5
Fire dampers & Smoke evacuation	6
Air valves	7
Roof hoods	8
Other circular products	9
Transfer	10
Rectangular	11
Flexible ducting	12
Isol	13
Access doors	14
Smart tools	15
Duct suspensions & Support systems	16
Fastening material	17
Index	18

Content – Transfer

1	Ducts	SRTR..... 479 TSRTR..... 480		Take-off	ILTR 511	
2	Slide-on stub			End cover	EPTR 512	
3	Telescopic duct	ILRTR 481 LRTR 482 PTR 483 TLTR1 484 TLTR2 485		Transition pieces	OUTR..... 513 MFTR..... 514 OTR 515 LORTR..... 516	
4	Bends	BTR 90° 487 BTR 60° 488 BTR 45° 489 BTR 30° 490 BTR 15° 491		Extraction hoods	SH..... 517 SHTR 518 SPTR 519	
5		BSTR 90° 492 BSTR 60° 493 BSTR 45° 494 BSTR 30° 495 BSTR 15° 496		Waste extractor	GSTR 520	
6		BSFTR 90° 497 BSFTR 60° 498 BSFTR 45° 499 BSFTR 30° 500 BSFTR 15° 501		Flexible hoses	THTR 521 THVTR 522	
7	Reducer	RCLTR 502		Transition piece (to hose)	OTRTH..... 523	
8	T-piece	TVTR30° 504		Clips	SB..... 524 SB1 525 SB-2 526	
9	X-piece	XVTR30° 505		Sealing clamp	MFK 527	
10	Y-piece	YVTR30° 506		Sliding dampers	See chapter Dampers and Measure units SKMTR 325 SKPTR 326	
11	Saddle	PSVTR30° 507 PSTR..... 508				
12	Collar saddle					
13						
14						
15						
16						
17						
18						

Description

Transfer – the duct system which is quick and easy to assemble and take apart

Transfer is the circular duct system with tension clips for quick assembly and disassembly. The system is supplied as standard with clips in dimensions Ø80 to Ø500 and with FL flanges in dimensions Ø560 to Ø900. Please refer to page 491.

Dust explosions

There is always a risk of dust explosion in installations where finely-divided material is transported.

A dust explosion occurs when a critical mixture of finely divided material and air is ignited and burns rapidly with consequent rapid expansion and pressure rise. A common cause of ignition is a spark from electrostatic discharge. Dust and sawdust extraction installations must be designed to minimise sources of fire and explosion.

Noise

In particle transport systems, where the pressure differs between in- and outside is big and where a little leakage may cause noise, the joints ought to be taped if low noise levels are required.

Applications

The duct system is suitable for

- Particle transportation from woodworking, such as saw mills, carpenters, furniture manufacturers and craft workshops.
- Comfort ventilation.
- Extraction systems for better working environment.
- Plasma cutters.
- Specially designed ventilation plants where you have extra demands for form, colour and appearance.

Please contact Lindab if you need other applications or to transport other materials, and if there are special operation circumstances.

Mountings

The types of mountings and their distances shall be chosen so that no sagging occurs in the system, and as justified for safe installation.

Maintenance

The duct system does not normally need any maintenance, but regular checks for wear should be made.

Advantages of the Transfer system

- Facilitates inspection and cleaning thanks to quick and simple disassembly.
- Facilitates environmental checking of the duct system.
- Rational joining, without screws or blind rivets.
- Has well-protected seal mouldings inside the clips.
- Can be twisted and adjusted after installation.
- Gives straight assembly.
- Does not have any sharp edges in the joints, since the bead is swaged directly on the fittings.
- Is highly suitable for transporting light material by means of air (chip extraction).
- Thanks to the bead, components are round and stiff.
- Does not require couplings.
- Transition pieces available for the Safe systems etc.
- Has lower pressure drop than the Safe system.
- Quick and easy to assemble and disassemble.

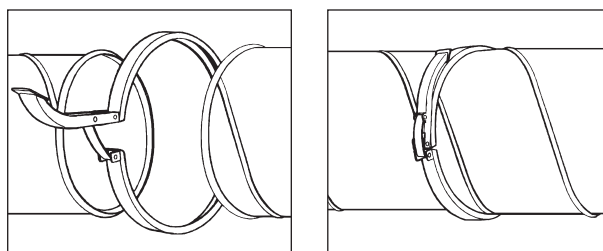

General

Dimensions of ducts and fittings

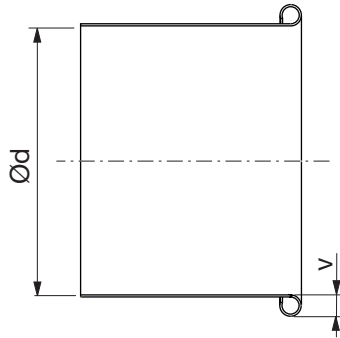

$\varnothing d$ nom	$\varnothing d$ mm	v mm
80	78	6
100	98	6
125	123	6
140	138	6
150	148	6
160	158	6
180	178	8
200	198	8
224	224	8
250	250	8
300	300	10
315	315	10
350	350	10
400	400	10
450	450	10
500	500	10
560–900 with flanges		

Angle tolerances

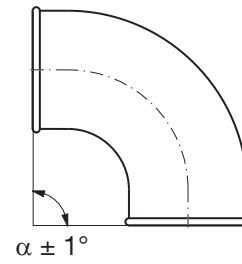



Description

Circular spiral swaged duct with projecting seam.

The duct has end stubs swaged on, with Transfer beads at each end.

Please refer to page 56 for technical data about ducts.

Please refer to pages 56 for technical data about ducts.

Dimensions

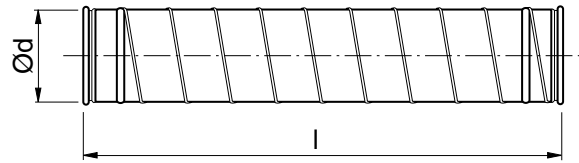

Ød nom	t std mm	500 mm	1000 mm	1500 mm	2000 mm	3000 mm	6000 mm
Weight for standard lengths, kg							
80	0,45	0,55	1,10	1,65	2,20	3,30	6,60
100	0,45	0,74	1,37	2,11	2,74	4,11	8,22
125	0,45	0,82	1,64	2,46	3,28	4,92	9,84
140	0,5	1,00	2,00	3,00	4,00	6,00	12,0
150	0,5	1,10	2,20	3,30	4,40	6,60	13,2
160	0,5	1,20	2,30	3,50	4,60	6,90	13,8
180	0,5	1,30	2,60	3,90	5,20	7,80	15,6
200	0,5	1,40	2,90	4,30	5,80	8,70	17,4
224	0,6	1,90	3,80	5,80	7,70	11,5	23,0
250	0,5	1,80	3,60	5,40	7,20	10,8	21,6
300	0,6	2,60	5,20	7,80	10,4	15,6	31,2
315	0,6	2,80	5,50	8,30	11,0	16,5	33,0
350	0,6	3,10	6,20	9,30	12,4	18,6	37,2
400	0,6	3,50	7,00	10,5	14,0	21,0	42,0
450	0,6	3,90	7,80	11,7	15,6	23,4	46,8
500	0,7	5,10	10,2	15,2	20,3	30,5	60,9
560 *	0,8	11,7	18,2	24,7	31,2	44,2	83,3
600 *	0,8	12,5	19,5	26,5	33,4	47,4	89,2
630 *	0,7	11,3	17,6	23,9	30,2	42,8	80,6
710 *	0,8	14,8	23,0	31,2	39,4	55,9	105
800 *	0,8	16,5	25,7	35,1	44,4	63,0	119
900 *	0,8	17,8	28,3	38,8	49,2	70,2	133

* Supplied with flange FL

Ordering example

	SRTR	200	3000
Product			
Dimension Ød			
Length l			



Dimensions

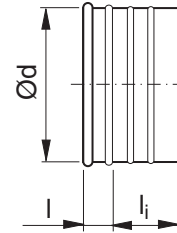

Description

Slide-on stub for installation in ducts of type SR.

After the duct has been shortened/fitted, add sealant etc between the swaged seams on the slide-on stub, after which the slide-on stub is inserted into the duct. The two swaged seams guide and retain the slide-on stub.

To finish off, the edge of the stub is swaged, both to remove the sharp edge of the transition and to fix the slide-on stub.

Please refer to the shortening instruction on page 486.

Is also used as transition piece OTRTH between Transfer and flexible hose THVTR. See page 522.

Please refer to the shortening instruction on page 486.

Is also used as transition piece OTRTH between Transfer and flexible hose THVTR. See page 522.

Ød nom	t mm	l mm	li mm	m kg
80	0,7	18	44	0,10
100	0,7	18	44	0,10
125	0,7	18	44	0,20
140	0,7	18	44	0,20
150	0,7	18	44	0,20
160	0,7	18	44	0,20
180	0,7	20	37	0,30
200	0,7	20	37	0,30
224	0,7	20	37	0,30
250	0,7	20	37	0,30
300	0,9	22	32	0,40
315	0,9	22	32	0,50
350	0,9	22	32	0,50
400	0,9	22	32	0,70
450	0,9	22	32	0,80
500	0,9	22	32	0,90

Ordering example

Product	TSRTR	200
Dimension Ød		



Description

Slide-on stub for installation in ducts of type SR in dimension range Ø560–900 where flange FL is used for joining.

After the duct has been shortened/fitted, add sealant etc between the swaged seams on the slide-on stub, after which the slide-on stub is inserted into the duct. The two swaged seams guide and retain the slide-on stub.

To finish off, the edge of the stub is swaged to both remove the sharp edge of the transition, and to fix the slide-on stub.

Please refer to the shortening instruction on page 486.

Please refer to the shortening instruction on page 486.

Dimensions

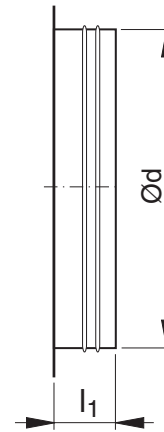

Ød nom	l ₁ mm	m kg
560	80	0,90
600	80	1,00
630	80	1,00
710	100	1,40
800	100	2,00
900	100	2,20

Ordering example

Product	ILRTR	800
Dimension Ød		

1

2

3

4

5

6

7

8

9

10

11

12

13

14

15

16

17

18



Dimensions

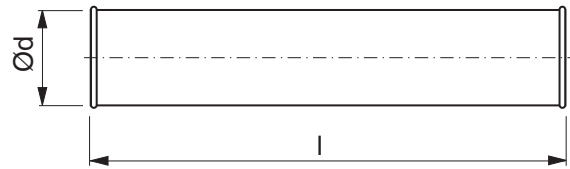

Description

Circular lengthways swaged duct with external seam.

Ød nom	t std mm	1000 mm Max permissible static negative pressure, kPa	2000 mm	3000 mm
80	0,6	36,0		
100	0,6	34,0	25,0	
125	0,6	32,0	24,0	
140	0,6	29,0	21,0	
150	0,6	25,0	18,0	
160	0,6	22,0	16,0	
180	0,7	21,0	15,5	
200	0,7	21,0	15,0	
224	0,7	20,0	14,5	
250	0,7	19,5	14,0	10,0
300	0,7	18,5	13,5	9,5
315	0,7	18,0	13,0	9,0
350	0,7	16,0	12,0	8,0
400	0,9	19,0	14,0	8,5
450	0,9	16,0	12,0	7,0
500	0,9	14,0	10,0	6,0
560	0,9			
600	0,9			
630	0,9			
650	0,9			
710	0,9			
750	0,9			
800	0,9			
900	0,9			

Ød nom	t std mm	500 mm	1000 mm	1500 mm	2000 mm	2960** mm
Weight for standard lengths, kg						
80	0,6	0,70	1,30			
100	0,6	0,80	1,68	2,50	3,40	
125	0,6	1,00	2,09	3,10	4,20	
140	0,6	1,10	2,29	3,40	4,60	
150	0,6	1,20	2,49	3,70	5,00	
160	0,6	1,30	2,69	4,00	5,40	
180	0,7	1,80	3,6	5,40	7,20	
200	0,7	1,90	3,89	5,80	7,80	
224	0,7	2,20	4,4	6,60	8,80	
250	0,7	2,40	4,88	7,30	9,80	14,6*
300	0,7	2,90	5,88	8,80	11,8	17,6**
315	0,7	3,10	6,2	9,30	12,4	18,6**
350	0,7	3,50	7	10,5	14,0	21,0**
400	0,9	4,70	9,4	14,1	18,8	28,2**
450	0,9	5,30	10,6	15,9	21,2	31,8**
500	0,9	5,90	11,8	17,7	23,6	35,4**
560***	0,9	11,8	18,4	25,0		
600***	0,9	12,6	19,7	26,7		
630***	0,9	13,2	20,7	27,1		
650***	0,9	13,6	21,3	28,9		
710***	0,9	14,9	23,3	31,6		
750***	0,9	15,7	24,6	33,4		
800***	0,9	16,6	26,1	35,5		
900***	0,9	18,8	29,4	40,0		

* t = 0,9; l = 2970

** t = 0,9

*** Supplied with flange FL

Ordering example

Product	LRTR	200	2000
Dimension Ød			
Length l			



Description

Slide-on stub for installation in ducts of type LRTR.

After the duct has been shortened/fitted the slide-on stub is inserted into the duct, after which the slide-on stub is sealed and fixed with putty or an sealing clamp such as MFK.

Turn the join during assembly, to face away from the direction of air flow.

Please refer to the shortening instruction on page 486.

Please refer to the shortening instruction on page 486.

Dimensions

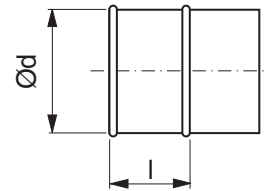

Ød nom	t mm	l mm	m kg
80	0,5	58	0,20
100	0,5	58	0,20
125	0,5	58	0,30
140	0,5	58	0,30
150	0,5	58	0,40
160	0,6	58	0,40
180	0,6	53	0,40
200	0,6	53	0,40
224	0,6	53	0,40
250	0,6	53	0,30
300	0,6	49	0,60
315	0,6	49	0,40
350	0,6	49	0,80
400	0,7	49	1,20
450	0,7	49	1,30
500	0,7	49	1,50

Folded design

Ordering example

Product	PTR	200
Dimension Ød		

- 1
- 2
- 3
- 4
- 5
- 6
- 7
- 8
- 9
- 10**
- 11
- 12
- 13
- 14
- 15
- 16
- 17
- 18



Description

Used together with telescopic duct TLTR 2 where it is necessary to adjust duct length when the standard lengths are not sufficient.

Fits also inside ducts of type SRTR Ø 80–200 and LRTR Ø 80–500.

For SRTR Ø 224–500 use the special duct TLSR.

Dimensions

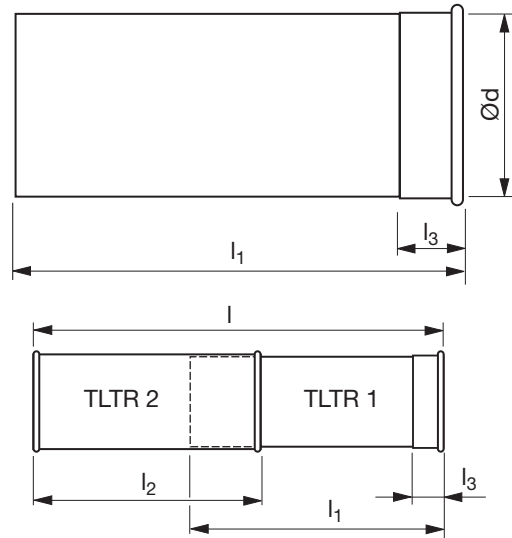

Ød nom	t mm	l ₁ , l ₂ mm	l ₃ mm	l _{min} mm	l _{max} mm	m kg
80	0,7	220	30	250	410	0,40
100	0,7	220	30	250	410	0,45
125	0,7	220	30	250	410	0,55
140	0,7	220	60	280	410	0,60
150	0,7	220	30	250	410	0,65
160	0,7	220	30	250	410	0,70
180	0,7	220	30	250	410	0,80
200	0,7	350	30	380	670	1,35
224	0,7	350	30	380	670	1,50
250	0,7	350	30	380	670	1,70
300	0,7	350	60	410	670	2,05
315	0,7	350	30	380	670	2,15
350	0,7	350	60	410	670	2,40
400	0,9	350	60	410	670	3,30
450	0,9	350	60	410	670	3,70
500	0,9	350	60	410	670	4,10

Seal the joint after assembly by using either:

- Mastic or tape
- O-ring ORINGTR + clip SB or SB-2

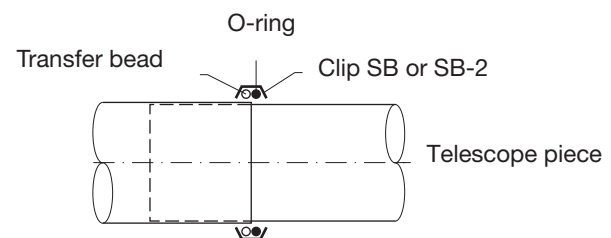

Ordering example

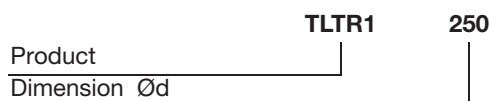



Description

Used together with telescopic duct TLTR 1 where it is necessary to adjust duct length when the standard lengths are not sufficient.

Can also be used as an ordinary duct.

Dimensions

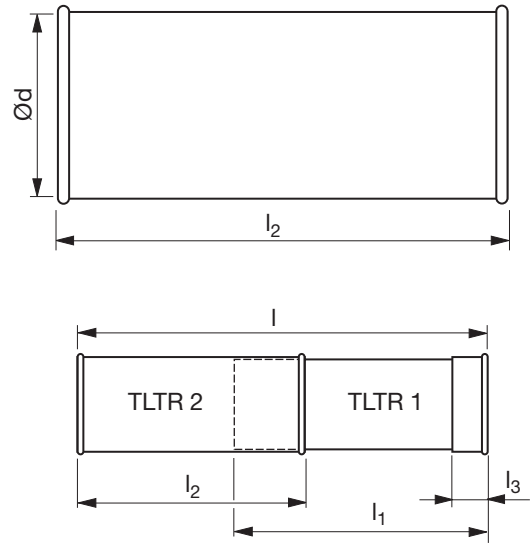

$\varnothing d$ nom	t mm	l_1, l_2 mm	l_3 mm	l_{min} mm	l_{max} mm	m kg
80	0,7	220	30	250	410	0,40
100	0,7	220	30	250	410	0,45
125	0,7	220	30	250	410	0,55
140	0,7	220	60	280	410	0,60
150	0,7	220	30	250	410	0,65
160	0,7	220	30	250	410	0,70
180	0,7	220	30	250	410	0,80
200	0,7	350	30	380	670	1,35
224	0,7	350	30	380	670	1,50
250	0,7	350	30	380	670	1,70
300	0,7	350	60	410	670	2,05
315	0,7	350	30	380	670	2,15
350	0,7	350	60	410	670	2,40
400	0,9	350	60	410	670	3,30
450	0,9	350	60	410	670	3,70
500	0,9	350	60	410	670	4,10

Seal the joint after assembly by using either:

- Mastic or tape
- O-ring ORINGTR + clip SB or SB-2

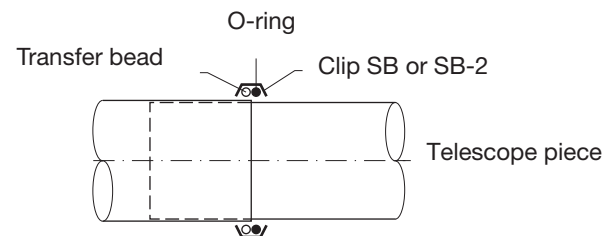

Ordering example

Product	TLTR2	250
Dimension $\varnothing d$		

Instruction for shortening for length adaptation of Transfer ducts

1

Spiral swaged duct SRTR

Adaption with fixed length

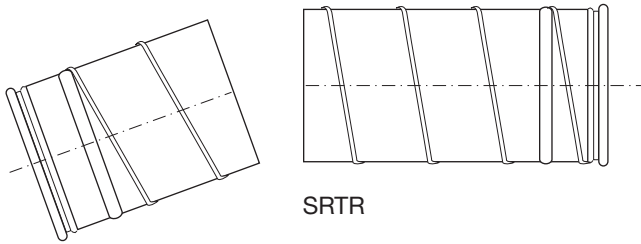

SRTR

Shorten the duct to the desired length. Also consider the installation length of the slide-on stub.

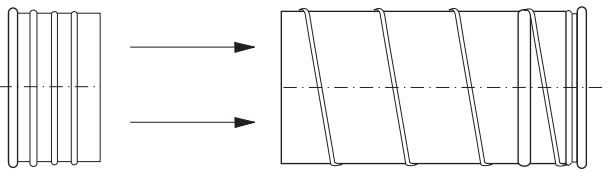

TSRTR

SRTR

Install slide-on stub TSRTR (please refer to page 480).

Adaption with flexible length

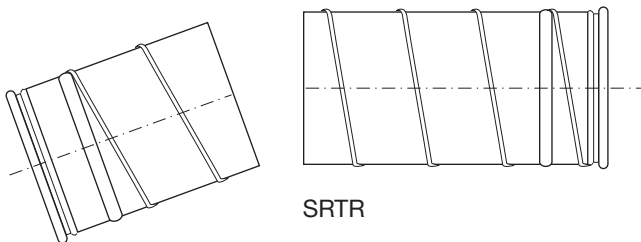

SRTR

Shorten the duct to the desired length. Also consider the installation length of the slide-on stub.

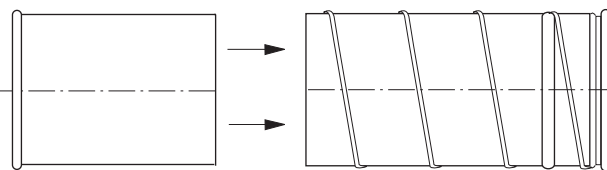

TLTR 1/TLSR

SRTR

Install telescopic duct

For Ø80–200 use TLTR-1 (page 484)

For Ø224–500 use TLSR (page 484)

Remember to

Turn the duct so that the joint does not point towards the direction of the air flow.

2

3

4

5

6

7

8

9

10

11

12

13

14

15

16

17

18

Lengthways swaged duct LRTR

Adaption with fixed length

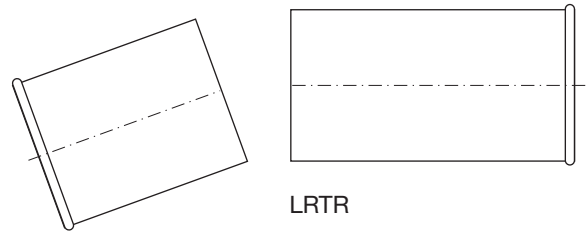

LRTR

Shorten the duct to the desired length. Also consider the installation length of the slide-on stub.

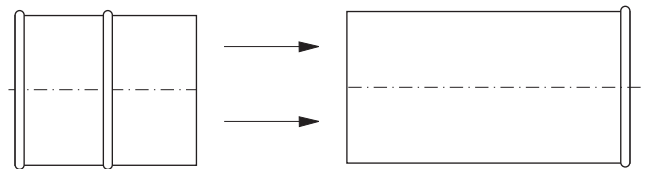

PTR

LRTR

Install slide-on stub PTR (please refer to page 483).

Adaption with flexible length

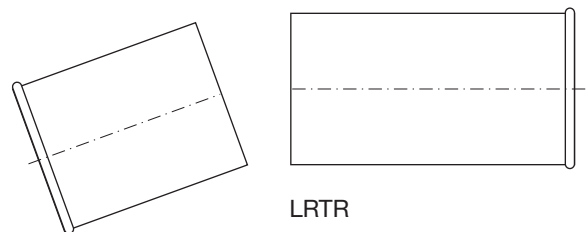

LRTR

Shorten the duct to the desired length. Also consider the installation length of the slide-on stub.

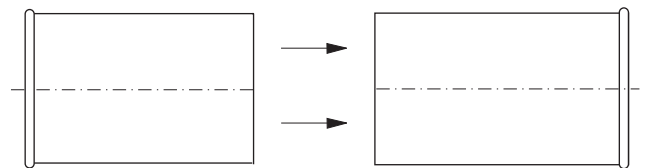

TLTR 1

LRTR

Install telescopic duct

Use TLTR-1 (page 484)

Remember to

Turn the duct so that the joint does not point towards the direction of the air flow.



Description

Pressed and seam welded bend.

Dimensions

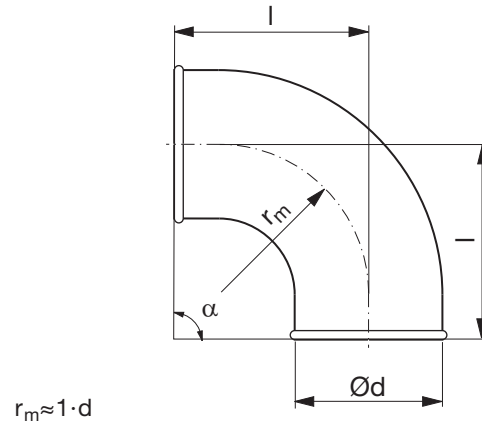

Ød nom	t mm	r _m mm	l mm	m kg
80	0,5	100	135	0,31
100	0,5	100	130	0,30
125	0,5	125	155	0,50
140	0,7	135	165	0,70
150	0,7	150	180	0,80
160	0,6	160	190	0,65
180	0,7	180	205	1,00
200 **	0,7	200	252	1,20
224 **	0,7	225	277	1,37
250 **	0,7	250	302	1,71

** 2 swaged-on ends

Ordering example

	BTR	125	90
Product			
Dimension Ød			
Angle α			





Dimensions

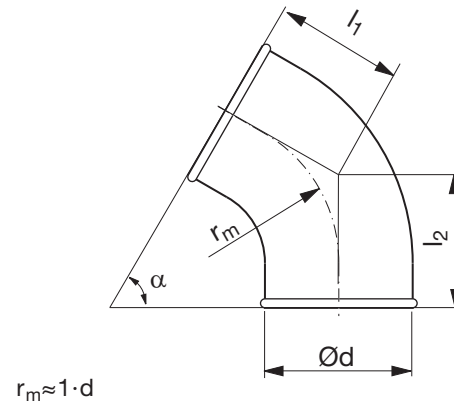

Description

Pressed and seam welded bend.

Ød nom	t mm	r _m mm	l ₁ mm	l ₂ mm	m kg
80 *	0,5	100	88	114	0,20
100	0,5	100	108	108	0,20
125	0,6	125	122	122	0,25
140 *	0,7	135	108	134	0,50
150 *	0,7	150	117	143	0,51
160 *	0,6	160	122	148	0,51
180 *	0,7	180	129	156	0,80
200 **	0,7	200	167	167	0,86
224 **	0,7	225	182	182	1,03
250 **	0,7	250	196	196	1,20

* 1 swaged-on end

** 2 swaged-on ends

Ordering example

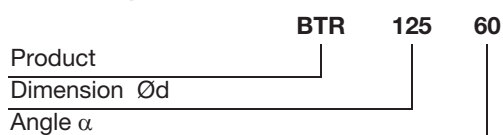



Description

Pressed and seam welded bend.

Dimensions

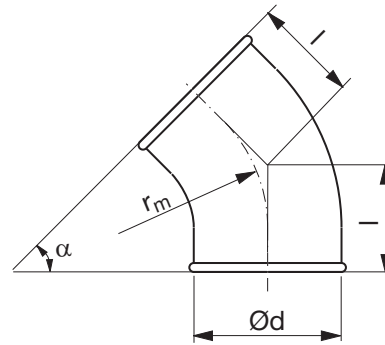

$$r_m \approx 1 \cdot d$$

$\varnothing d$ nom	t mm	r_m mm	l mm	m kg
80	0,5	100	71	0,20
100	0,5	100	71	0,30
125	0,5	125	82	0,30
140	0,7	135	86	0,40
150	0,7	150	92	0,43
160	0,6	160	96	0,43
180	0,7	180	110	0,68
200 **	0,6	200	135	0,80
224 **	0,7	225	145	0,86
250 **	0,7	250	156	0,86

** 2 swaged-on ends

Ordering example

	BTR	125	45
Product			
Dimension $\varnothing d$			
Angle α			





Dimensions

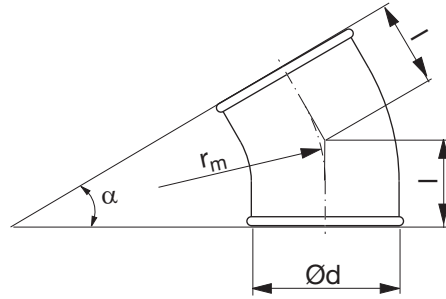

$$r_m \approx 1 \cdot d$$

Description

Pressed and seam welded bend.

Ød nom	t mm	r _m mm	l mm	m kg
80	0,5	100	57	0,20
100	0,5	100	57	0,20
125	0,6	125	63	0,25
140	0,7	140	68	0,40
150	0,7	150	70	0,34
160	0,7	160	73	0,50
180	0,7	180	73	0,60
200 **	0,7	200	106	0,80
224 **	0,7	225	112	0,77
250 **	0,7	250	119	1,10

** 2 swaged-on ends

Ordering example

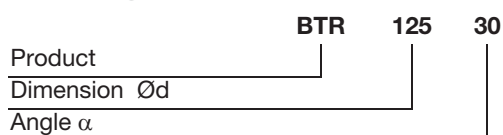



Description

Pressed and seam welded bend.

Dimensions

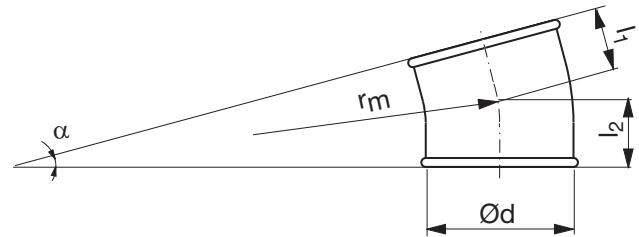

$$r_m \approx 1 \cdot d$$

Ød nom	t mm	r _m mm	l ₁ mm	l ₂ mm	m kg
80 *	0,5	100	43	69	0,10
100	0,5	100	43	43	0,20
125	0,5	125	46	46	0,14
140 **	0,7	140	74	74	0,30
150 **	0,6	150	76	76	0,26
160	0,5	160	51	51	0,14
180 **	0,7	180	76	76	0,40
200 **	0,7	200	78	78	0,43
224 **	0,7	225	81	81	0,60

* 1 swaged-on end

** 2 swaged-on ends

Ordering example

	BTR	125	15
Product			
Dimension Ød			
Angle α			





Dimensions

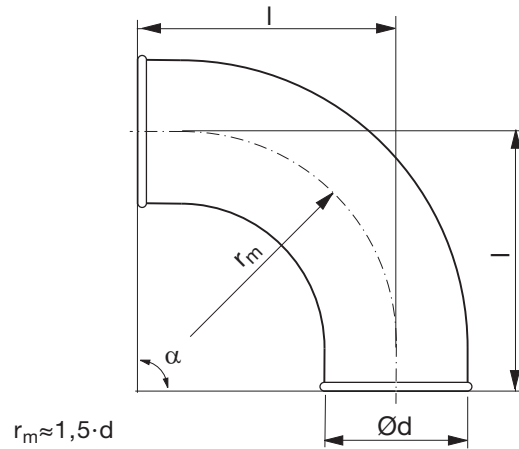

Description

Pressed and seam welded bend.

Ød nom	t mm	r_m mm	l mm	m kg
100	0,6	150	180	0,50
125	0,7	190	220	0,80
150	0,7	225	255	1,10
160	0,7	240	270	1,20
180	0,7	270	295	1,60
200 **	0,6	300	352	1,63

** 2 swaged-on ends

Ordering example

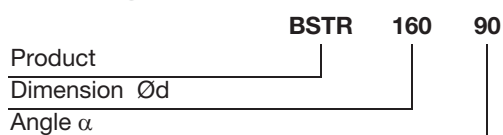



Description

Pressed and seam welded bend.

Dimensions

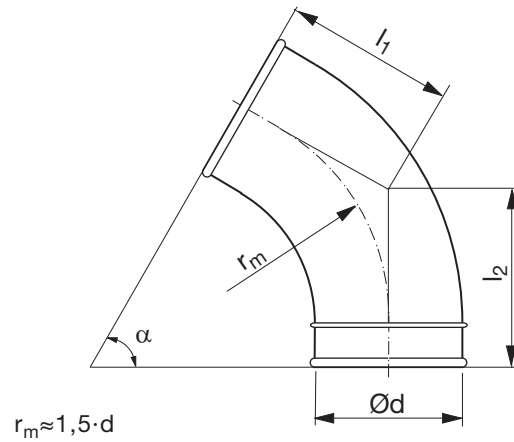

Ød nom	t mm	r _m mm	l ₁ mm	l ₂ mm	m kg
100 *	0,6	150	117	143	0,40
125 *	0,7	190	140	166	0,60
150 *	0,7	225	160	186	0,70
160 *	0,7	240	169	195	0,80
180 *	0,7	270	181	208	1,20
200 **	0,7	300	225	225	1,13

* 1 swaged-on end

** 2 swaged-on ends

Ordering example

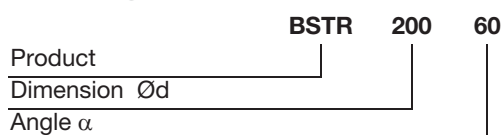



Dimensions

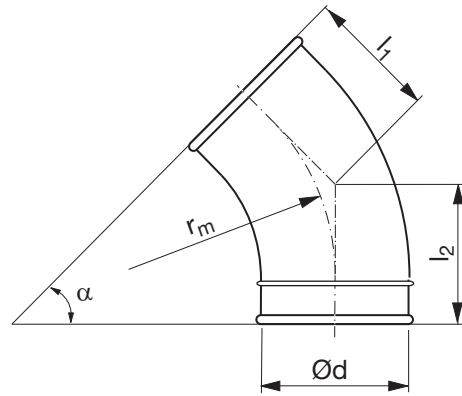

$$r_m \approx 1,5 \cdot d$$

Description

Pressed and seam welded bend.

Ød nom	t mm	r _m mm	l ₁ mm	l ₂ mm	m kg
100 *	0,6	150	92	118	0,30
125 *	0,7	190	109	135	0,40
150 *	0,7	225	123	149	0,50
160 *	0,7	240	129	155	0,60
180 *	0,7	270	137	164	0,90
200 **	0,6	300	176	176	0,88

* 1 swaged-on end

** 2 swaged-on ends

Ordering example

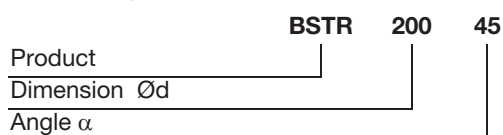



Description

Pressed and seam welded bend.

Dimensions

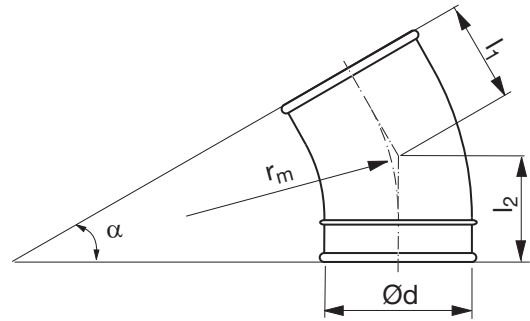

$$r_m \approx 1,5 \cdot d$$

$\varnothing d$ nom	t mm	r_m mm	l_1 mm	l_2 mm	m kg
100 *	0,6	150	70	96	0,30
125 *	0,7	190	81	107	0,30
150 *	0,7	225	90	116	0,50
160 *	0,7	240	94	120	0,50
180 *	0,7	270	97	124	0,70
200 **	0,7	300	132	132	0,79

* 1 swaged-on end

** 2 swaged-on ends

Ordering example

	BSTR	160	30
Product			
Dimension $\varnothing d$			
Angle α			





Dimensions

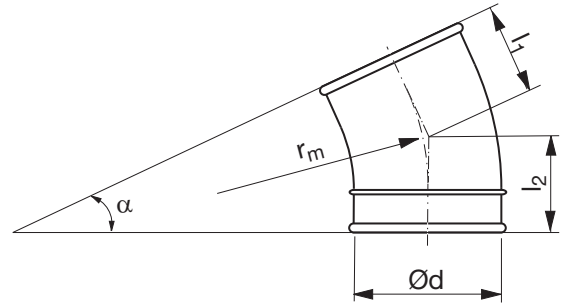

$$r_m \approx 1,5 \cdot d$$

Description

Pressed and seam welded bend.

Ød nom	t mm	r _m mm	l ₁ mm	l ₂ mm	m kg
100 *	0,6	150	50	76	0,20
125 *	0,7	190	55	81	0,40
150 *	0,7	225	60	86	0,40
160 *	0,7	240	62	88	0,40
180 *	0,7	270	61	88	0,50
200 **	0,7	300	91	91	0,62

* 1 swaged-on end

** 2 swaged-on ends

Ordering example

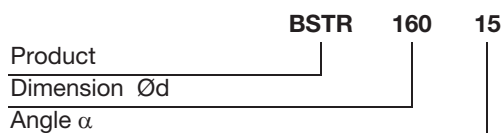

Bend

BSFTR 90°



Description

Segmented and swaged bend.

Dimensions

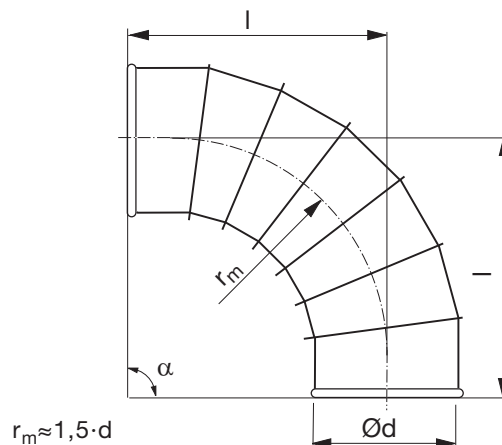

Ød nom	t mm	r _m mm	l mm	m kg
200	0,7	300	387	3,40
224	0,7	336	423	4,20
250	0,7	375	462	4,90
300	0,7	450	531	6,40
315	0,7	472	553	7,10
350	0,7	525	606	9,00
400	0,9	600	681	13,1
450	0,9	675	756	16,2
500	0,9	750	831	19,5
560 *	0,9	840	875	29,3
600 *	0,9	900	935	32,7
630 *	0,9	945	980	37,3
650 *	0,9	975	1010	41,4
710 *	0,9	1065	1100	47,0
750 *	0,9	1125	1160	51,1
800 *	0,9	1200	1235	54,5
900 *	0,9	1350	1385	74,8

* Supplied with flange FL

Ordering example

	BSFTR	250	90
Product			
Dimension Ød			
Angle α			



Dimensions

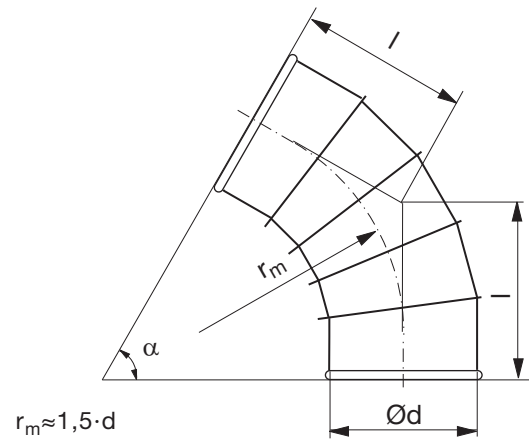

Description

Segmented and swaged bend.

Ød nom	t mm	r _m mm	l mm	m kg
200	0,7	300	260	2,30
224	0,7	336	281	2,70
250	0,7	375	304	3,10
300	0,7	450	341	4,20
315	0,7	472	354	4,60
350	0,7	525	384	5,60
400	0,9	600	427	8,10
450	0,9	675	471	10,1
500	0,9	750	514	12,1
560 *	0,9	840	520	20,8
600 *	0,9	900	555	23,5
630 *	0,9	945	581	24,6
650 *	0,9	975	598	27,2
710 *	0,9	1065	650	36,4
750 *	0,9	1125	685	40,4
800 *	0,9	1200	728	42,3
900 *	0,9	1350	814	45,1

* Supplied with flange FL

Ordering example

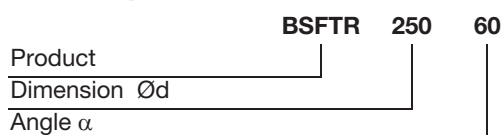



Description

Segmented and swaged bend.

Dimensions

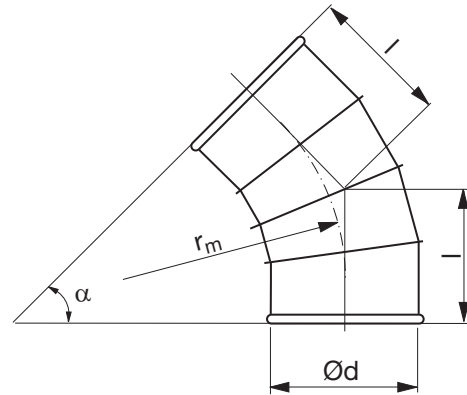

$$r_m \approx 1,5 \cdot d$$

Ød nom	t mm	r _m mm	l mm	m kg
200	0,7	300	211	1,90
224	0,7	336	226	2,20
250	0,7	375	242	2,50
300	0,7	450	267	3,40
315	0,7	472	277	3,70
350	0,7	525	298	4,50
400	0,9	600	330	6,50
450	0,9	675	361	7,90
500	0,9	750	392	9,40
560 *	0,9	840	383	16,7
600 *	0,9	900	408	18,5
630 *	0,9	945	426	20,1
650 *	0,9	975	439	22,3
710 *	0,9	1065	476	26,4
750 *	0,9	1125	501	28,6
800 *	0,9	1200	532	31,8
900 *	0,9	1350	594	34,9

* Supplied with flange FL

Ordering example

Product	BSFTR	250	45
Dimension Ød			
Angle α			





Dimensions

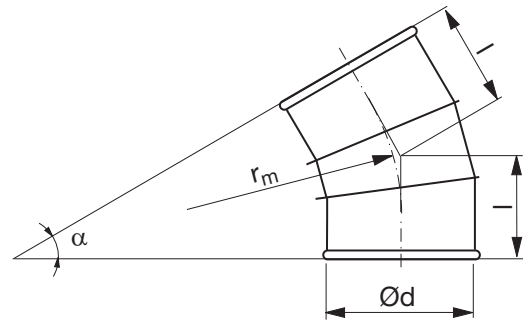

$$r_m \approx 1,5 \cdot d$$

Description

Segmented and swaged bend.

Ød nom	t mm	r _m mm	l mm	m kg
200	0,7	300	167	1,50
224	0,7	336	177	1,70
250	0,7	375	187	1,90
300	0,7	450	202	2,50
315	0,7	472	208	2,80
350	0,7	525	222	3,40
400	0,9	600	242	4,90
450	0,9	675	262	5,80
500	0,9	750	282	6,80
560 *	0,9	840	260	12,7
600 *	0,9	900	276	14,5
630 *	0,9	945	288	15,7
650 *	0,9	975	296	18,4
710 *	0,9	1065	320	20,2
750 *	0,9	1125	336	21,5
800 *	0,9	1200	357	24,9
900 *	0,9	1350	397	29,6

* Supplied with flange FL

Ordering example

	BSFTR	250	30
Product			
Dimension Ød			
Angle α			



Description

Segmented and swaged bend.

Dimensions

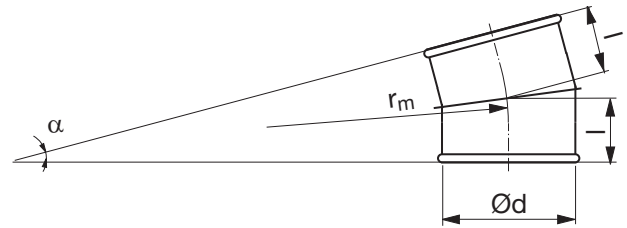

$$r_m \approx 1,5 \cdot d$$

Ød nom	t mm	r _m mm	l mm	m kg
200	0,7	300	126	1,10
224	0,7	336	131	1,30
250	0,7	375	136	1,50
300	0,7	450	140	2,00
315	0,7	472	143	2,40
350	0,7	525	150	2,90
400	0,9	600	160	4,50
450	0,9	675	170	5,40
500	0,9	750	180	6,20
560 *	0,9	840	146	11,8
600 *	0,9	900	153	13,4
630 *	0,9	945	159	15,6
650 *	0,9	975	163	16,4
710 *	0,9	1065	175	18,3
750 *	0,9	1125	183	19,6
800 *	0,9	1200	193	22,4
900 *	0,9	1350	213	26,3

* Supplied with flange FL

Ordering example

	BSFTR	250	15
Product			
Dimension Ød			
Angle α			





Description

Long, concentric reducer with about 18° angle.

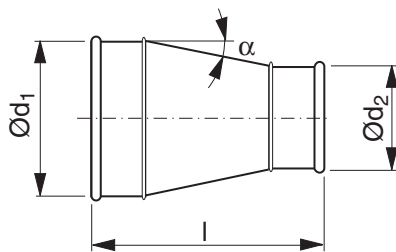

Dimensions

Ød ₁ nom	Ød ₂ nom	t mm	l mm	m kg
100	80	0,7	162	0,30
125	80	0,7	196	0,40
125	100	0,7	168	0,40
140	80	0,7	216	0,60
140	100	0,7	189	0,40
140	125	0,7	155	0,40
150	80	0,7	230	0,60
150	100	0,7	203	0,60
150	125	0,7	168	0,40
150	140	0,7	148	0,40
160	80	0,7	244	0,70
160	100	0,7	216	0,60
160	125	0,7	182	0,50
160	140	0,7	161	0,60
160	150	0,7	148	0,40
180	100	0,7	239	0,60
180	125	0,7	205	0,60
180	140	0,7	184	0,60
180	150	0,7	170	0,60
180	160	0,7	157	0,50
200	125	0,7	232	0,80
200	140	0,7	211	0,70
200	150	0,7	198	0,70
200	160	0,7	184	0,60
200	180	0,7	152	0,50
224	140	0,7	244	1,00
224	150	0,7	231	1,00
224	160	0,7	217	0,80
224	180	0,7	184	0,80
224	200	0,7	157	0,70
250	140	0,7	280	1,30
250	150	0,7	266	1,30
250	160	0,7	253	1,10
250	180	0,7	220	1,00
250	200	0,7	193	1,00
250	224	0,7	160	1,00
300	150	0,7	332	1,70
300	160	0,7	318	1,70
300	180	0,7	286	1,70
300	200	0,7	258	1,50
300	250	0,7	190	1,40
315	160	0,7	339	1,60
315	180	0,7	307	1,60
315	200	0,7	279	1,50
315	224	0,7	246	1,40

Ordering example

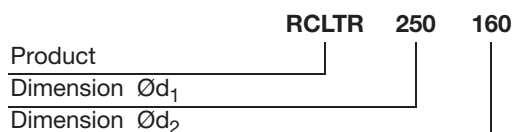

Ød ₁ nom	Ød ₂ nom	t mm	l mm	m kg
315	250	0,7	210	1,40
315	300	0,7	139	1,30
350	180	0,7	361	2,00
350	200	0,7	334	2,00
350	224	0,7	301	2,10
350	250	0,7	265	1,90
350	300	0,7	194	1,70
350	315	0,7	173	1,40
400	180	0,7	428	2,80
400	200	0,7	401	2,80
400	224	0,7	368	3,00
400	250	0,7	332	2,60
400	300	0,7	260	2,70
400	315	0,7	240	2,30
400	350	0,7	185	2,00
450	200	0,7	469	3,50
450	224	0,7	437	3,80
450	250	0,7	401	3,30
450	300	0,7	329	3,40
450	315	0,7	309	2,90
450	350	0,7	254	2,60
450	400	0,9	197	2,80
500	224	0,7	505	4,30
500	250	0,7	469	4,00
500	300	0,7	398	4,00
500	315	0,7	377	3,80
500	350	0,7	322	3,40
500	400	0,9	265	3,60
500	450	0,9	197	3,20
560 *	250	0,7	578	8,20
560 *	300	0,9	506	8,00
560 *	315	0,7	485	7,80
560 *	350	0,7	431	7,60
560 *	400	0,9	374	7,40
560 *	450	0,9	305	7,00
560 *	500	0,9	236	6,50
600 *	300	0,9	561	8,60
600 *	315	0,7	541	8,60
600 *	350	0,7	486	8,20
600 *	400	0,9	429	8,20
600 *	450	0,9	360	7,70
600 *	500	0,9	291	7,20
600 *	560	0,9	235	6,40
630 *	315	0,7	582	8,60
630 *	350	0,7	527	8,00
630 *	400	0,9	470	7,90
630 *	450	0,9	401	7,40
630 *	500	0,9	333	7,00

Ød ₁ nom	Ød ₂ nom	t mm	l mm	m kg
630 *	560 *	0,9	276	9,30
630 *	600	0,9	221	8,80
650 *	350	0,9	547	8,40
650 *	400	0,9	490	8,30
650 *	450	0,9	421	7,80
650 *	500	0,9	353	7,40
650 *	560 *	0,9	296	9,70
650 *	600 *	0,9	241	9,20
650 *	630 *	0,9	221	9,00
710 *	400	0,9	605	9,60
710 *	450	0,9	536	9,20
710 *	500	0,9	467	8,70
710 *	560 *	0,9	411	11,1
710 *	600 *	0,9	356	10,6
710 *	630 *	0,9	315	10,2
750 *	450	0,9	566	9,60
750 *	500	0,9	497	9,10
750 *	560 *	0,9	441	11,5
750 *	600 *	0,9	386	11,0
750 *	630 *	0,9	345	10,6
750 *	650 *	0,9	325	10,4
750 *	710 *	0,9	290	10,0
800 *	500	0,9	591	11,0
800 *	560 *	0,9	535	13,4
800 *	600 *	0,9	480	12,9
800 *	630 *	0,9	439	12,5
800 *	650 *	0,9	419	12,1
800 *	710 *	0,9	354	11,6
800 *	750 *	0,9	325	11,2
900 *	560 *	0,9	697	17,7
900 *	600 *	0,9	642	17,0
900 *	630 *	0,9	601	16,5
900 *	650 *	0,9	570	16,1
900 *	710 *	0,9	516	15,3
900 *	750 *	0,9	450	14,9
900 *	800 *	0,9	392	13,8

* Supplied with flange FL





Dimensions

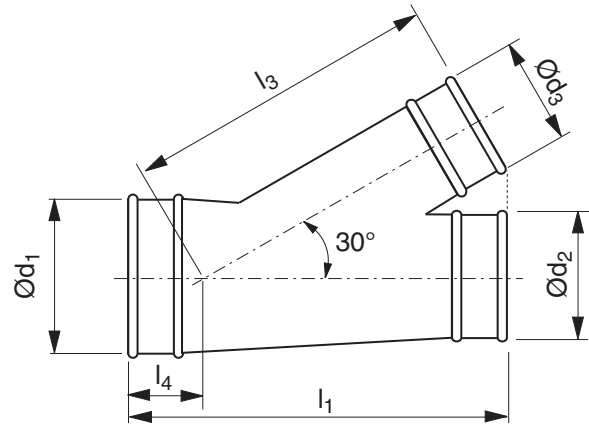

Description

T-piece.

NB

To save space, the adjacent table only contains a limited selection from our range the T-pieces where all dimensions d_1 , d_2 and d_3 are equal in size. Other dimensions are available to special order.

In all combinations, the installation length l_1 is only governed by the branch diameter d_3 . For example, all T-pieces with $d_3 = 200$ have installation length $l_1 = 589$ mm.

$\text{Ø}d_1$ nom	$\text{Ø}d_2$ nom	$\text{Ø}d_3$ nom	t mm	l_1 mm	l_3 mm	l_4 mm	m kg
80	80	80	0,7	358	263	109	0,90
100	100	100	0,7	398	301	112	1,20
125	125	125	0,7	448	347	116	1,60
140	140	140	0,7	478	375	118	1,80
150	150	150	0,7	498	394	119	2,00
160	160	160	0,7	518	413	120	2,30
180	180	180	0,7	549	445	119	2,80
200	200	200	0,7	589	482	121	3,40
224	224	224	0,7	637	527	124	4,20
250	250	250	0,7	689	576	128	4,90
300	300	300	0,7	777	662	129	7,00
315	315	315	0,7	807	690	131	7,30
350	350	350	0,7	960	755	177	9,00
400	400	400	0,9	1060	848	184	14,0
450	450	450	0,9	1160	842	190	16,9
500	500	500	0,9	1260	1035	197	20,1
560*	560*	560*	0,9	1520	1245	275	26,0
600*	600*	600*	0,9	1600	1320	280	29,0
630*	630*	630*	0,9	1660	1376	284	31,0
650*	650*	650*	0,9	1700	1413	287	34,0
710*	710*	710*	0,9	1820	1525	295	41,0
750*	750*	750*	0,9	1900	1600	301	45,0
800*	800*	800*	0,9	2000	1693	307	51,0
900*	900*	900*	0,9	2200	1879	321	64,0

* Supplied with flange FL

Ordering example

	TVTR30	315	200	200
Product				
Dimension $\text{Ø}d_1$				
Dimension $\text{Ø}d_2$				
Dimension $\text{Ø}d_3$				



Description

X-piece.

NB

To save space, the adjacent table only contains a limited selection from our range the X-pieces where all dimensions d_1 , d_2 and d_3/d_4 are equal in size. Other dimensions are available to special order.

In all combinations, the installation length l_1 is only governed by the larger branch diameter d_3/d_4 . For example, all X-pieces with $d_3 = 160$ and $d_4 = 200$ have installation length $l_1 = 589$ mm.

Dimensions

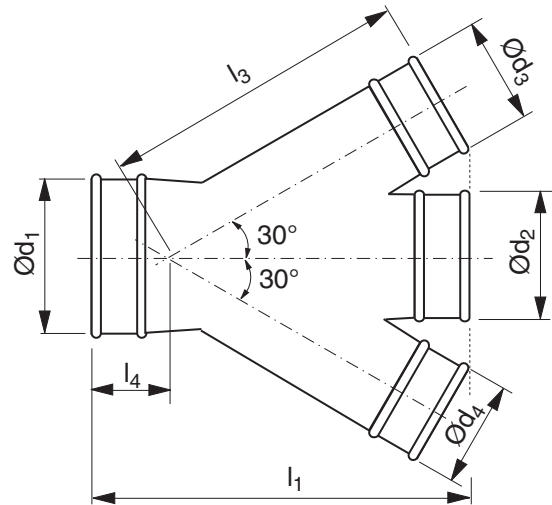

Ød ₁ nom	Ød ₂ nom	Ød ₃ Ød ₄ nom	t mm	l ₁ mm	l ₃ mm	l ₄ mm	m kg
80	80	80	0,7	358	263	109	1,10
100	100	100	0,7	398	301	112	1,40
125	125	125	0,7	448	347	116	1,80
140	140	140	0,7	478	375	118	2,10
150	150	150	0,7	498	394	119	2,30
160	160	160	0,7	518	413	120	2,60
180	180	180	0,7	549	445	119	3,20
200	200	200	0,7	589	482	121	4,00
224	224	224	0,7	637	527	124	4,90
250	250	250	0,7	689	576	128	5,80
300	300	300	0,7	777	662	129	8,80
315	315	315	0,7	807	690	131	9,30
350	350	350	0,7	960	755	177	11,2
400	400	400	0,9	1060	848	184	18,8
450	450	450	0,9	1160	842	190	22,2
500	500	500	0,9	1260	1035	197	26,8
560 *	560 *	560 *	0,9	1520	1245	275	34,0
600 *	600 *	600 *	0,9	1600	1320	280	39,0
630 *	630 *	630 *	0,9	1660	1376	284	41,0
650 *	650 *	650 *	0,9	1700	1413	295	46,0
710 *	710 *	710 *	0,9	1820	1525	295	54,0
750 *	750 *	750 *	0,9	1900	1600	301	60,0
800 *	800 *	800 *	0,9	2000	1693	307	68,0
900 *	900 *	900 *	0,9	2200	1879	321	85,0

* Supplied with flange FL

Ordering example

Product	XVTR30	400	200	160	160
Dimension Ød ₁					
Dimension Ød ₂					
Dimension Ød ₃					
Dimension Ød ₄					





Dimensions

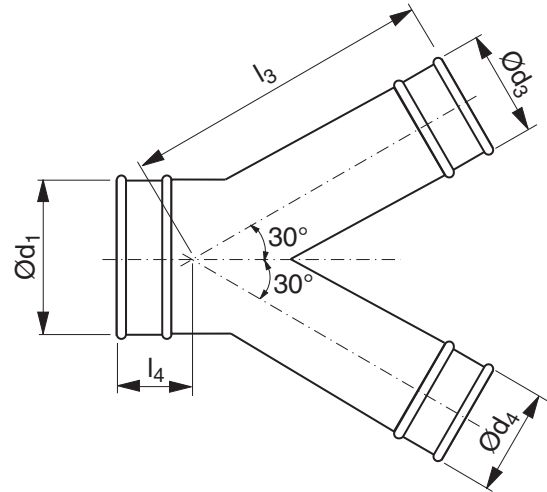

Description

Y-piece.

NB

To save space, the adjacent table only contains a limited selection from our range the Y-pieces where all dimensions d_1 , d_3 and d_4 are equal in size. Other dimensions are available to special order.

$\text{Ø}d_1$ nom	$\text{Ø}d_3$ $\text{Ø}d_4$ nom	t mm	l_3 mm	l_4 mm	m kg
80	80	0,7	191	65	0,70
100	100	0,7	213	67	0,80
125	125	0,7	242	71	0,90
140	140	0,7	259	73	1,10
150	150	0,7	270	74	1,20
160	160	0,7	281	75	1,30
180	180	0,7	304	73	1,60
200	200	0,7	327	76	2,00
224	224	0,7	354	79	2,50
250	250	0,7	383	82	2,90
300	300	0,7	440	82	4,40
315	315	0,7	457	84	4,70
350	350	0,7	497	89	5,40
400	400	0,9	554	96	9,00
450	450	0,9	610	102	10,8
500	500	0,9	667	109	13,1
560 *	560 *	0,9	735	155	17,0
600 *	600 *	0,9	780	160	19,5
630 *	630 *	0,9	814	164	20,5
650 *	650 *	0,9	837	167	23,0
710 *	710 *	0,9	905	195	27,0
750 *	750 *	0,9	951	201	30,0
800 *	800 *	0,9	1007	207	38,0
900 *	900 *	0,9	1121	221	47,0

* Supplied with flange FL

Ordering example

	YVTR30	400	160	160
Product				
Dimension $\text{Ø}d_1$				
Dimension $\text{Ø}d_2$				
Dimension $\text{Ø}d_3$				

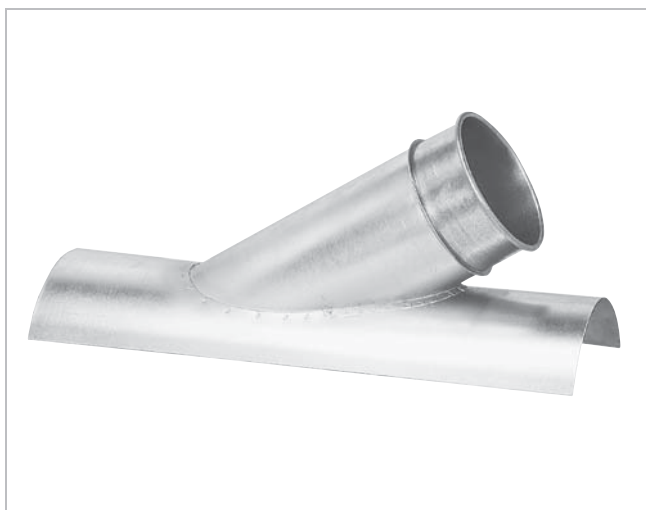

Description

Saddle.

The saddle is fixed with two sealing clamps MFK.

This product should not be installed with screws or blind rivets when used in chip extraction installations.

NB

To save space, the adjacent table only contains a limited selection from our range the saddles where all dimensions d and d_3 are equal in size. Other dimensions are available to special order.

Dimensions

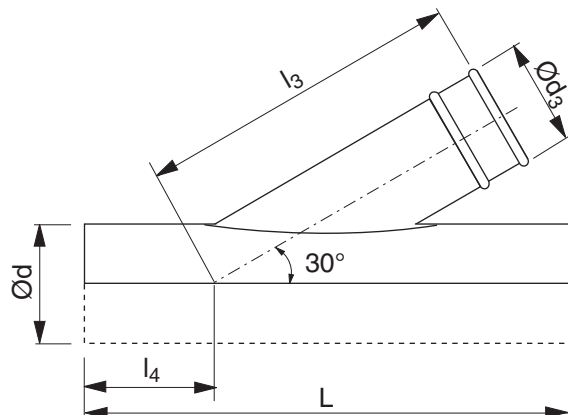

Ød nom	Ød ₃ nom	t mm	L mm	l ₃ mm	l ₄ mm	m kg
80	80	0,7	410	221	136	0,50
100	100	0,7	450	263	138	0,60
125	125	0,7	500	317	142	0,80
140	140	0,7	530	349	144	0,90
150	150	0,7	550	370	145	1,00
160	160	0,7	570	391	146	1,20
180	180	0,7	610	434	149	1,50
200	200	0,7	650	477	152	1,70
224	224	0,7	700	528	156	2,10
250	250	0,7	750	584	159	2,40
300	300	0,7	850	690	165	3,10
315	315	0,7	880	722	167	3,60
350	350	0,7	950	797	172	5,60
400	400	0,9	1050	904	179	6,50
450	450	0,9	1150	1010	185	8,20
500	500	0,9	1250	1117	192	9,80
560	560 *	0,9	1370	1245	200	11,2
600	600 *	0,9	1450	1330	205	13,8
630	630 *	0,9	1510	1394	209	14,0
650	650 *	0,9	1550	1437	212	16,0
710	710 *	0,9	1670	1565	220	18,0
750	750 *	0,9	1750	1651	225	21,0
800	800 *	0,9	1850	1757	232	24,0
900	900 *	0,9	2050	1971	245	28,0

* Supplied with flange FL

Ordering example

Product	PSVTR30	400	160
Dimension Ød			
Dimension Ød ₃			



Dimensions

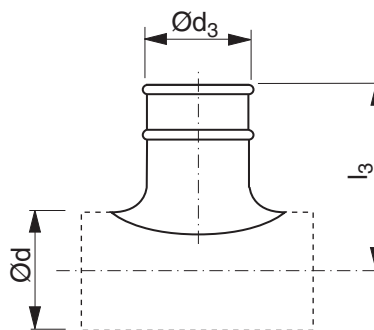

Description

Collar saddle.

Ød nom	Ød ₃ mm	t mm	l ₃ mm	m kg
80	80	0,6	143	0,20
100	80	0,6	156	0,20
100	100	0,6	131	0,30
125	80	0,6	166	0,20
125	100	0,6	144	0,30
125	125	0,6	149	0,40
140	80	0,6	173	0,20
140	100	0,6	176	0,40
140	125	0,6	121	0,30
140	140	0,6	181	0,50
150	80	0,6	178	0,20
150	100	0,6	181	0,40
150	125	0,6	186	0,50
150	140	0,6	186	0,50
150	150	0,6	186	0,50
160	80	0,6	183	0,20
160	100	0,6	161	0,30
160	125	0,6	166	0,40
160	140	0,6	191	0,50
160	150	0,6	191	0,50
160	160	0,6	171	0,50
180	80	0,6	193	0,20
180	100	0,6	196	0,40
180	125	0,6	201	0,50
180	140	0,6	201	0,50
180	150	0,6	201	0,50
180	160	0,6	206	0,60
180	180	0,6	202	0,90
200	80	0,6	203	0,20
200	100	0,6	181	0,30
200	125	0,6	181	0,40
200	140	0,6	211	0,50
200	150	0,6	211	0,50
200	160	0,6	191	0,50

Ordering example

Product	PSTR	400	160
Dimension Ød			
Dimension Ød ₃			

Ød nom	Ød ₃ mm	t mm	l ₃ mm	m kg
200	180	0,6	212	0,90
200	200	0,6	212	1,00
224	80	0,6	215	0,20
224	100	0,6	218	0,40
224	125	0,6	223	0,50
224	140	0,6	223	0,50
224	150	0,6	223	0,50
224	160	0,6	228	0,60
224	180	0,6	224	0,80
224	200	0,6	224	0,80
224	224	0,6	224	1,00
250	80	0,6	228	0,30
250	100	0,6	206	0,40
250	125	0,6	211	0,40
250	140	0,6	236	0,50
250	150	0,6	236	0,50
250	160	0,6	241	0,60
250	180	0,6	237	0,90
250	200	0,6	237	0,90
250	224	0,6	237	1,20
250	250	0,6	257	1,30
300	80	0,6	201	0,20
300	100	0,6	201	0,20
300	125	0,6	201	0,30
300	140	0,6	201	0,40
300	150	0,6	201	0,40
300	160	0,6	201	0,40
300	180	0,6	197	0,60
300	200	0,6	197	0,60
300	224	0,6	197	0,70
300	250	0,6	197	0,80
315	80	0,6	261	0,30
315	100	0,6	264	0,40
315	125	0,6	244	0,40
315	140	0,6	269	0,50
315	150	0,6	269	0,50
315	160	0,6	273	0,50
315	180	0,6	273	0,90
315	200	0,6	269	0,90
315	224	0,6	269	0,90
315	250	0,6	289	1,10
315	300	0,6	259	1,50
315	315	0,6	283	1,90
350	100	0,6	226	0,30
350	125	0,6	226	0,30
350	140	0,6	226	0,40
350	150	0,6	226	0,40
350	160	0,6	226	0,40
350	180	0,6	222	0,60
350	200	0,6	222	0,70

Ød nom	Ød ₃ mm	t mm	l ₃ mm	m kg
350	224	0,6	222	0,70
350	250	0,6	222	0,80
350	300	0,6	216	0,90
350	315	0,6	216	1,10
350	350	0,6	216	1,60
400	125	0,6	311	0,40
400	140	0,6	251	0,30
400	150	0,6	311	0,40
400	160	0,6	316	0,50
400	180	0,6	247	0,40
400	200	0,6	312	0,90
400	224	0,6	312	0,90
400	250	0,6	332	1,10
400	300	0,6	301	1,10
400	315	0,6	326	1,60
400	350	0,6	326	1,90
400	400	0,7	321	2,40
450	100	0,6	331	0,40
450	125	0,6	336	0,50
450	140	0,6	276	0,40
450	150	0,6	336	0,40
450	160	0,6	341	0,50
450	180	0,6	272	0,40
450	200	0,6	337	0,90
450	224	0,6	337	0,90
450	250	0,6	357	1,10
450	300	0,6	266	1,00
450	315	0,6	351	1,50
450	400	0,7	371	2,30
450	450	0,7	266	1,40
500	100	0,6	356	0,40
500	125	0,6	361	0,50
500	140	0,6	301	0,30
500	150	0,6	361	0,40
500	160	0,6	366	0,50
500	180	0,6	297	0,50
500	200	0,6	362	0,90
500	224	0,6	322	0,70
500	250	0,6	382	1,10
500	300	0,6	291	0,90
500	315	0,6	376	1,50
500	350	0,7	291	1,70
500	400	0,7	396	2,30
500	450	0,7	291	1,50
500	500	0,7	291	1,70
560	250	0,7	412	1,50
560	300	0,7	321	1,30
560	315	0,7	406	1,90
560	350	0,7	381	2,00
560	400	0,9	426	3,10

1

Ød nom	Ød ₃ mm	t mm	l ₃ mm	m kg
560	450	0,9	321	2,70
560	500	0,9	321	3,10
560	560 *	0,9	321	5,70
600	300	0,7	341	1,40
600	315	0,7	426	1,90
600	350	0,7	341	1,70
600	400	0,9	446	3,10
600	450	0,9	341	2,70
600	500	0,9	341	3,30
600	560 *	0,9	341	5,80
600	600 *	0,9	341	6,30
630	315	0,7	441	2,10
630	350	0,7	356	1,80
630	400	0,9	461	3,30
630	450	0,9	356	2,80
630	500	0,9	356	3,50
630	560 *	0,9	356	5,90
630	600 *	0,9	356	6,40
630	630 *	0,9	356	6,80
650	350	0,7	366	1,90
650	400	0,9	366	2,60
650	450	0,9	366	2,90
650	500	0,9	366	3,60
650	560 *	0,9	366	6,00
650	600 *	0,9	366	6,50
650	630 *	0,9	366	6,90
650	650 *	0,9	366	7,20
710	400	0,9	396	3,00
710	450	0,9	396	3,10
710	500	0,9	396	3,80
710	560 *	0,9	396	6,10
710	600 *	0,9	396	6,70
710	630 *	0,9	396	7,10
710	650 *	0,9	396	7,40
710	710 *	0,9	396	8,50
750	450	0,9	416	3,20
750	500	0,9	416	3,80
750	560 *	0,9	416	6,20
750	600 *	0,9	416	6,70
750	630 *	0,9	416	7,10
750	650 *	0,9	416	7,40
750	710 *	0,9	416	8,60
750	750 *	0,9	416	9,00
800	500	0,9	441	3,80
800	560 *	0,9	441	6,30
800	630 *	0,9	441	7,30
800	650 *	0,9	441	7,70
800	710 *	0,9	441	8,70
800	750 *	0,9	441	9,20
800	800 *	0,9	441	10,1

2

3

4

5

6

7

8

9

10

11

12

13

14

15

16

17

18

Ød nom	Ød ₃ mm	t mm	l ₃ mm	m kg
900	560 *	0,9	491	6,60
900	600 *	0,9	491	7,20
900	630 *	0,9	491	7,60
900	650 *	0,9	491	8,00
900	710 *	0,9	491	9,10
900	750 *	0,9	491	9,70
900	800 *	0,9	491	10,6
900	900 *	0,9	491	12,2

* Supplied with flange FL



Description

Take-off.

Dimensions

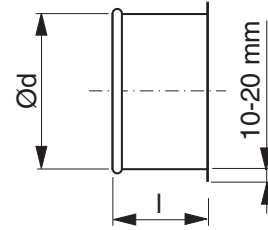

Ød nom	t mm	l mm	m kg
80	0,7	50	0,10
100	0,7	50	0,10
125	0,7	50	0,20
140	0,7	50	0,20
150	0,7	50	0,20
160	0,7	50	0,20
180	0,7	45	0,30
200	0,7	45	0,30
224	0,7	45	0,30
250	0,7	45	0,40
300	0,7	40	0,40
315	0,7	40	0,50
350	0,7	40	0,50
400	0,9	40	0,70
450	0,9	40	0,80
500	0,9	40	0,90

Ordering example

Product	ILTR	315
Dimension Ød		

- 1
- 2
- 3
- 4
- 5
- 6
- 7
- 8
- 9
- 10
- 11
- 12
- 13
- 14
- 15
- 16
- 17
- 18



Dimensions

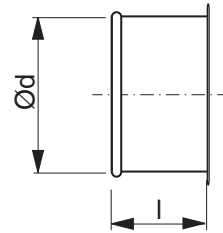

Description

End cover.

Ød nom	t mm	l mm	m kg
80	0,7	56	0,30
100	0,7	56	0,40
125	0,7	56	0,40
140	0,7	56	0,40
150	0,7	56	0,50
160	0,7	56	0,60
180	0,7	52	0,60
200	0,7	52	0,80
224	0,7	52	0,80
250	0,7	52	0,80
300	0,9	46	0,90
315	0,9	46	1,00
350	0,9	46	1,00
400	0,9	46	1,40
450	0,9	46	1,60
500	0,9	46	1,80
560 *	0,9	70	5,40
600 *	0,9	70	6,10
630 *	0,9	70	6,30
650 *	0,9	70	6,70
710 *	0,9	90	7,80
750 *	0,9	90	8,30
800 *	0,9	90	9,00
900 *	0,9	90	10,7

* Supplied with flange FL

Ordering example

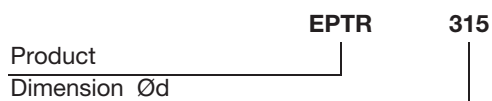



Description

Coupling between Transfer and Safe systems.

Dimensions

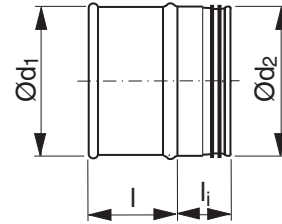

Ød ₁ nom	Ød ₂ nom	t mm	l mm	l _i mm	m kg
80	80	0,7	40	40	0,15
100	100	0,7	40	40	0,15
125	125	0,7	40	40	0,20
140	140	0,7	40	40	0,20
150	150	0,7	40	40	0,30
160	160	0,7	40	40	0,30
180	180	0,7	40	40	0,30
200	200	0,7	40	40	0,30
224	224	0,7	40	40	0,40
250	250	0,7	60	60	0,40
300	300	0,7	46	60	0,70
315	315	0,7	46	60	0,50
350	350	0,9	46	60	0,80
400	400	0,9	46	80	1,20
450	450	0,9	46	80	1,40
500	500	0,9	46	80	1,60
560	560	0,9	80	80	4,6
600	600	0,9	80	80	4,9
630	630	0,9	80	80	5,1
650	650	0,9	80	80	5,4
710	710	0,9	100	100	6,1
750	750	0,9	100	100	6,8
800	800	0,9	100	100	7,5
900	900	0,9	125	125	8,5

Ordering example

Product	OUTR	315
Dimension Ød		

- 1
- 2
- 3
- 4
- 5
- 6
- 7
- 8
- 9
- 10**
- 11
- 12
- 13
- 14
- 15
- 16
- 17
- 18



Dimensions

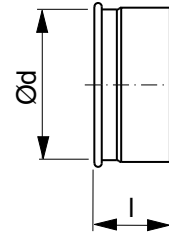

Description

Coupling with female end between Transfer and Safe systems.

Ød nom	t mm	l mm	m kg
80	0,7	62	0,10
100	0,7	62	0,10
125	0,7	62	0,20
140	0,7	62	0,20
150	0,7	62	0,20
160	0,7	62	0,20
180	0,7	58	0,20
200	0,7	58	0,20
224	0,7	58	0,30
250	0,7	79	0,30
300 *	0,9	106	0,70
315	0,9	73	0,30
350 *	0,9	115	0,9
400 *	0,9	126	1,20
450 *	0,9	126	1,40
500 *	0,9	126	1,60

* Folded design

Ordering example

Product	MFTR	315
Dimension Ød		



Dimensions

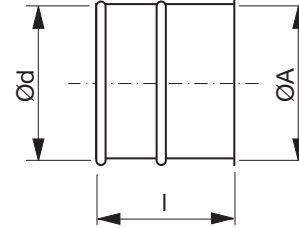

Description

Coupling between Transfer and other joining system.

As standard the length is 100 mm. If a specific length is desired it can be stated when order. The length depends on dimensions and joining system. Minimum length is 50 mm.

Ød : dimension for Transfer

ØA : dimension for other system

At order state the type of the other joining system.

Ød nom	t mm
80	0,7
100	0,7
125	0,7
140	0,7
150	0,7
160	0,7
180	0,7
200	0,7
224	0,7
250	0,7
300	0,9
315	0,9
350	0,9
400	0,9
450	0,9
500	0,9

Ordering example

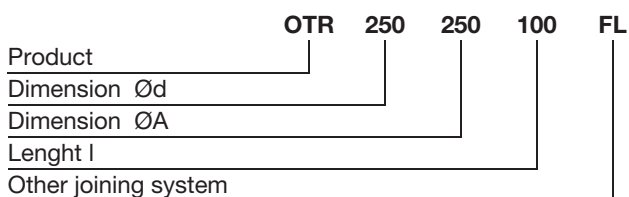

- 1
- 2
- 3
- 4
- 5
- 6
- 7
- 8
- 9
- 10**
- 11
- 12
- 13
- 14
- 15
- 16
- 17
- 18



Dimensions

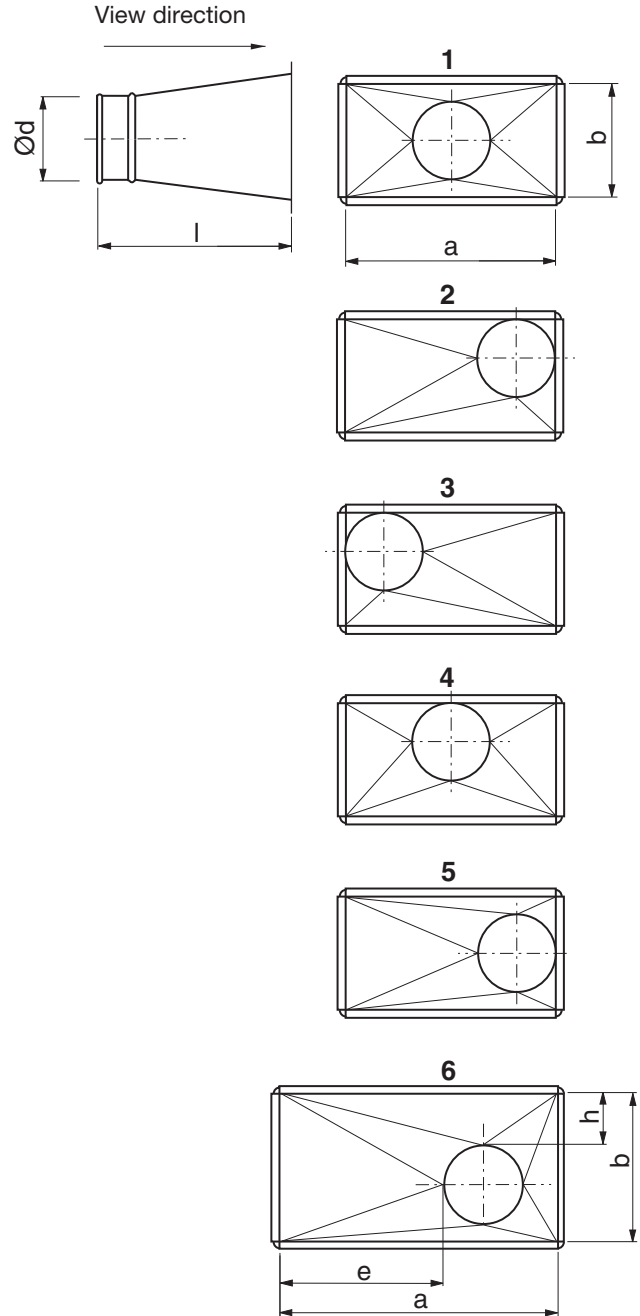

Description

Coupling between Transfer and rectangular connection.

The measures e and h only need to be specified for alternative 6. A negative value for e, for example, means that e is outside side a.

The measures e and h only need to be specified for alternative 6. A negative value for e, for example, means that e is outside side a.

Ordering example

Product	LORTR	500	300	160	1
Largest side	a				
Smallest side	b				
Diameter in mm	Ød				
The alt. displacement are seen from the circular end 1-6					

a, b Largest side mm	l mm
100 – 350	300
351 – 750	450
751 – 1200	600



Description

Extraction hood for all types of extraction.

Available in two standard sizes with various accessories such as a damper, net and magnet.

Dimensions

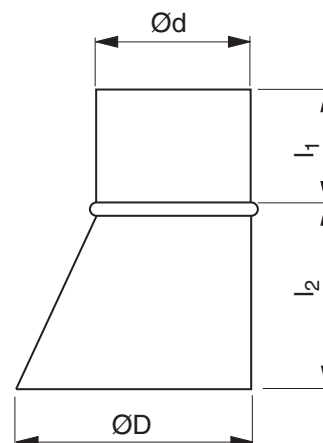

Ød nom	ØD nom	l ₁ mm	l ₂ mm	m kg
80	160	80	95	0,31
160 *	315	120	155	1,00

* Supplied with handle

Ordering example

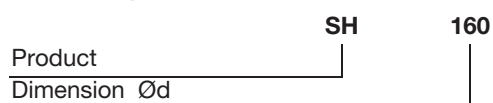

- 1
- 2
- 3
- 4
- 5
- 6
- 7
- 8
- 9
- 10**
- 11
- 12
- 13
- 14
- 15
- 16
- 17
- 18



Dimensions

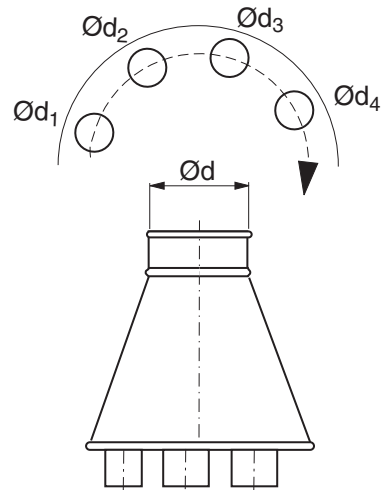

Description

Extraction hood.

To order, specify Ød and dimensions for stubs Ød_1 , Ød_2 , Ød_3 etc. and the sequence they should be located on the pitch circle.

Ød nom	t mm
80	0,7
100	0,7
125	0,7
140	0,7
150	0,7
160	0,7
180	0,7
200	0,7
224	0,7
250	0,7
300	0,7
315	0,7
350	0,7
400	0,9
450	0,9
500	0,9

Ordering example

Product	SHTR	250	xxx - xxx - xxx
Dimension Ød			
Dimension $\text{Ød}_1, \text{Ød}_2, \text{Ød}_3$			



Description

Extraction hood.

To order, specify $\varnothing d$ and dimensions for stubs $\varnothing d_1$, $\varnothing d_2$, $\varnothing d_3$ etc. and the sequence they should be located on the pitch circle.

Dimensions

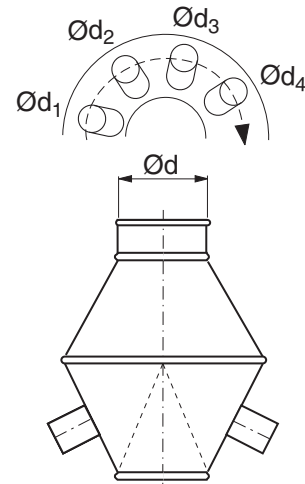

$\varnothing d$ nom	t mm
80	0,7
100	0,7
125	0,7
140	0,7
150	0,7
160	0,7
180	0,7
200	0,7
224	0,7
250	0,7
300	0,7
315	0,7
350	0,7
400	0,9
450	0,9
500	0,9

Ordering example

Product	SPTR	315	xxx - xxx - xxx
Dimension $\varnothing d$			
Dimension $\varnothing d_1, \varnothing d_2, \varnothing d_3$			

1

2

3

4

5

6

7

8

9

10

11

12

13

14

15

16

17

18

1

2

3

4

5



6

Description

Used for extraction of chips etc. Is to be placed up to a wall.

7

8

9

10

11

12

13

14

15

16

Ordering example

GSTR 125

Product

Dimension Ød

17

18

Dimensions

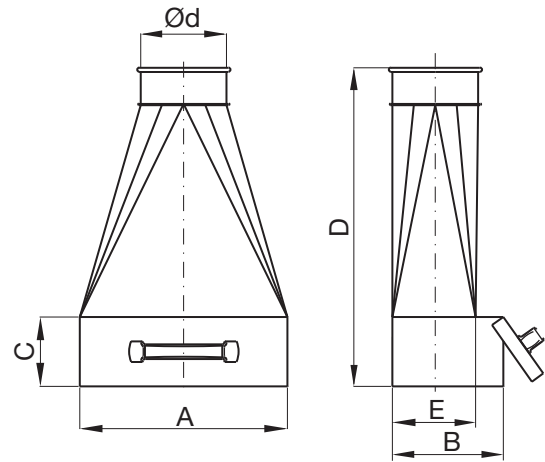

Ød nom	A mm	B mm	C mm	D mm	E mm
100	300	165	100	460	120
125	300	165	100	460	120
160	300	165	100	460	120

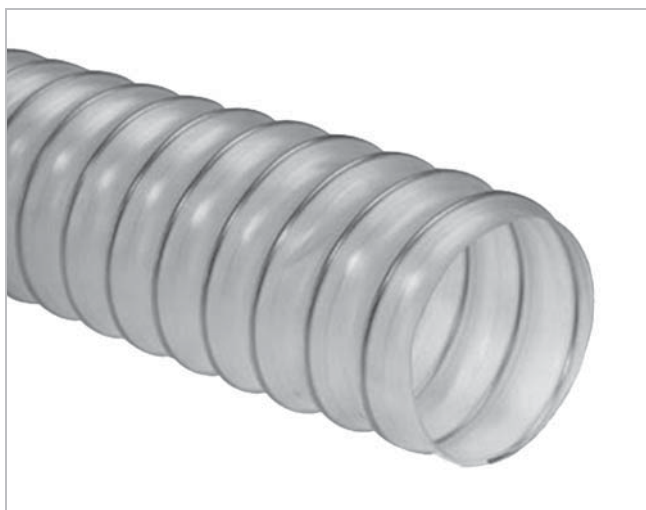

Description

Light, flexible hose built on a bright steel spiral. Transparent with a light bluish tone.

Material polyester – polyurethane

Temperature range -40 to +100 °C

Fits standard fitting dimensions.

Dimensions

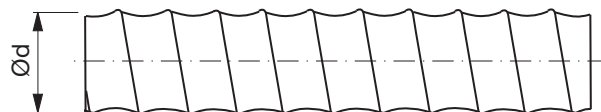

Ød mm	Min. bending radius mm	Max. per- missible negative pressure kPa	l mm	m _l kg/m
80	80	14,5	6000	0,50
100	100	12,0	6000	0,60
125	125	10,0	6000	0,70
140	140	8,0	6000	0,80
150	150	7,8	6000	0,90
160	160	7,5	6000	0,90
180	180	6,5	6000	1,00
200	200	6,2	6000	1,10
250	250	5,0	6000	1,40

Ordering example

Product	THTR	160
Dimension Ød		

- 1
- 2
- 3
- 4
- 5
- 6
- 7
- 8
- 9
- 10**
- 11
- 12
- 13
- 14
- 15
- 16
- 17
- 18



Dimensions

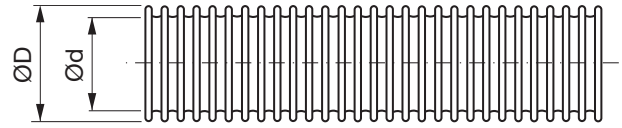

Description

Flexible hose, non-spiral, profiled wall construction, extruded ethylene-vinyl-acetate. The design means that the hose has an almost completely smooth interior under high vacuum, with consequent low pressure drop. This is because the open ridges on the inside of the hose are compressed at negative pressure.

Colour blue
 Temperature range -45 to +65 °C

Ød mm	ØD mm	Min. bending radius mm	Max. per- missible negative pressure kPa	l mm	m _l kg/m
25	31	66	50	30000	0,20
32	41	82	50	30000	0,30
38	48	93	50	30000	0,40
45	56	111	50	30000	0,50
50	61	122	50	30000	0,60
63	76	160	50	30000	0,80
76	91	188	50	15000	1,10
100	115	252	50	15000	1,50

Ordering example

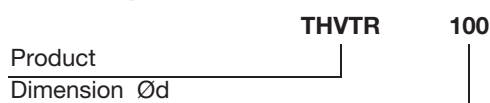



Description

Coupling between Transfer and flexible hose THVTR.

Dimensions

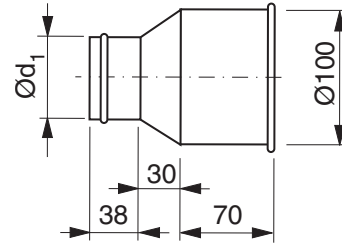

Ød_1 nom	m kg
25	0,19
32	0,20
38	0,20
45	0,20
50	0,21
63	0,21
76	0,22

Dim 80–250 use TSRTR page 480.

Ordering example

	OTRTH	50
Product		
Dimension Ød_1		

1

2

3

4

5

6

7

8

9

10

11

12

13

14

15

16

17

18



Dimensions

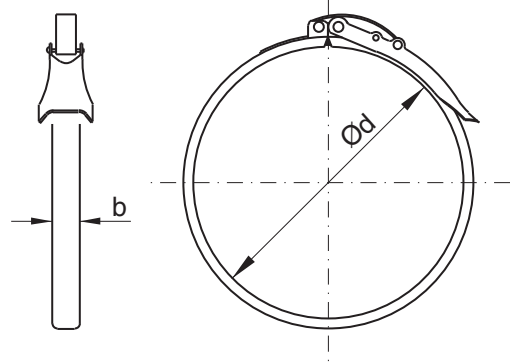

Description

The clip is provided with a rubber gasket. The clip handles can be secured against inadvertent opening by means of a lock pin.

Temperature range -30 to +75 °C continuous
-40 to +85 °C intermittent

Ød nom	b mm	m kg
80	14	0,10
100	14	0,10
125	14	0,10
140	14	0,10
150	14	0,10
160	14	0,10
180	19	0,20
200	19	0,30
224	19	0,30
250	19	0,30
300	25	0,40
315	25	0,50
350	25	0,60
400	25	0,60
450	25	0,70
500	25	0,80

Ordering example

Product	SB	400
Dimension Ød		



Dimensions

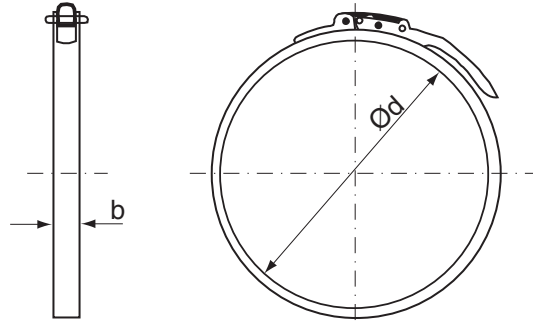

Description

Provided with a rubber gasket of EPDM rubber and a thread spring. The clip handle can be secured against inadvertent opening by means of a lock pin.

Temperature range -30 to +75 °C continuous
-40 to +85 °C intermittent

Ød nom	b mm	m kg
80	14	0,10
100	14	0,10
125	14	0,10
140	14	0,10
150	14	0,10
160	14	0,10
180	19	0,20
200	19	0,30
224	19	0,30
250	19	0,30
300	25	0,40
315	25	0,50
350	25	0,60
400	25	0,60
450	25	0,70
500	25	0,80

Ordering example

Product	SB1	250
Dimension Ød		

1

2

3

4

5

6

7

8

9

10

11

12

13

14

15

16

17

18



Dimensions

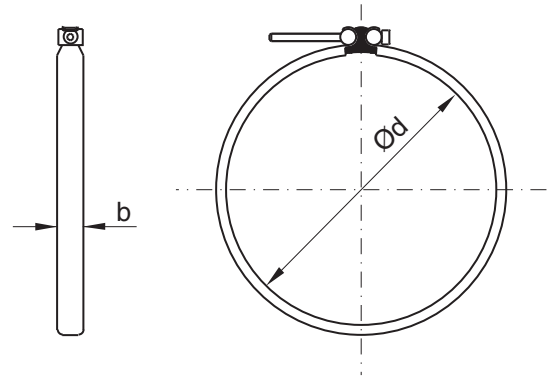

Description

The clip is provided with a rubber gasket. The clip is tensioned by means of a hexagonal socket cap screw. Suitable for tightening with a screw tightener.

Temperature range -30 to +75 °C continuous
-40 to +85 °C intermittent

Ød nom	b mm	Key size mm	m kg
80	14	3	0,10
100	14	3	0,10
125	14	3	0,10
140	14	3	0,10
150	14	3	0,10
160	14	3	0,10
180	19	3	0,20
200	19	3	0,30
224	19	3	0,30
250	19	3	0,30
300	25	5	0,40
315	25	5	0,50
350	25	5	0,60
400	25	5	0,60
450	25	5	0,70
500	25	5	0,80

Ordering example

Product	SB-2	200
Dimension Ød		



Description

The inside of the sealing clamp is clad with longlife resistant EPDM rubber.

Used for sealing joints on slide-on stub PTR and saddle PSVTR.

Dimensions

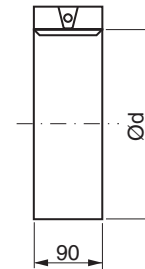

Ød mm	m kg
80	0,30
100	0,30
125	0,40
140	0,40
150	0,50
160	0,50
180	0,50
200	0,50
224	0,60
250	0,60
300	0,60
315	0,70
350	0,70
400	0,80
450	1,10
500	1,20

Ordering example

Product	MFK	200
Dimension Ød		