



Operating Instructions

VLT[®] Refrigeration Drive 110-250 kW

Contents

1 Safety	4
2 Introduction	5
2.1 Exploded Views	5
2.2 Purpose of the Manual	6
2.3 Additional Resources	6
2.4 Product Overview	6
2.5 Internal Controller Functions	6
3 Installation	8
3.1 Planning the Installation Site	8
3.2 Pre-Installation Checklist	8
3.3 Mechanical Installation	8
3.3.1 Cooling	8
3.3.2 Lifting	9
3.4 Electrical Installation	9
3.4.1 General Requirements	9
3.4.2 Earth (Ground) Requirements	12
3.4.2.1 Leakage Current (>3.5 mA)	12
3.4.2.2 Earthing (Grounding) IP20 Enclosures	13
3.4.2.3 Earthing (Grounding) IP21/54 Enclosures	13
3.4.3 Motor Connection	14
3.4.3.1 Motor Cable	17
3.4.3.2 Motor Rotation Check	17
3.4.4 AC Mains Input Connection	17
3.5 Control Wiring Connection	18
3.5.1 Access	18
3.5.2 Using Screened Control Cables	18
3.5.3 Earthing (Grounding) of Screened Control Cables	18
3.5.4 Control Terminal Types	19
3.5.5 Wiring to Control Terminals	19
3.5.6 Control Terminal Functions	19
3.6 Serial Communication	19
4 Start Up and Functional Test	21
4.1 Pre-start	21
4.2 Applying Power to the Frequency Converter	22
4.3 Basic Operational Programming	22
4.3.1 Set-up Wizard	22
4.4 Local-control Test	28

4.5 System Start Up	29
5 User Interface	30
5.1 Local Control Panel	30
5.1.1 LCP Layout	30
5.1.2 Setting LCP Display Values	31
5.1.3 Display	31
5.1.4 Navigation Keys	32
5.1.5 Operation Keys	32
5.2 Back Up and Copying Parameter Settings	32
5.2.1 Uploading Data to the LCP	33
5.2.2 Downloading Data from the LCP	33
5.3 Restoring Default Settings	33
5.3.1 Recommended Initialisation	33
5.3.2 Manual Initialisation	33
6 Programming	34
6.1 Introduction	34
6.2 Programming Example	34
6.3 Control Terminal Programming Examples	35
6.4 International/North American Default Parameter Settings	36
6.5 Parameter Menu Structure	37
6.5.1 Quick Menu Structure	38
6.5.2 Main Menu Structure	40
7 Application Set-Up Examples	44
7.1 Introduction	44
7.2 Set-up Examples	44
7.2.1 Compressor	44
7.2.2 Single or Multiple Fans or Pumps	44
7.2.3 Compressor Pack	46
8 Status Messages	47
8.1 Status Display	47
8.2 Status Message Definitions Table	47
9 Warnings and Alarms	50
9.1 System Monitoring	50
9.2 Warning and Alarm Types	50
9.2.1 Warnings	50
9.2.2 Alarm Trip	50
9.2.3 Alarm Trip-lock	50

9.3 Warning and Alarm Displays	50
9.4 Warning and Alarm Definitions	52
9.5 Fault Messages	54
10 Basic Troubleshooting	60
10.1 Start Up and Operation	60
11 Specifications	63
11.1 General Specifications	63
11.2 Mains Supply	68
11.3 Fuse Specifications	71
11.3.1 Protection	71
11.3.2 Non UL Compliance	71
11.3.3 UL Compliance	72
11.3.4 Connection Tightening Torques	72
Index	73

1 Safety

⚠ WARNING

HIGH VOLTAGE!

Frequency converters contain high voltage when connected to AC mains input power. Installation, start up, and maintenance should be performed by qualified personnel only. Failure to perform installation, start up, and maintenance by qualified personnel could result in death or serious injury.

High Voltage

Frequency converters are connected to hazardous mains voltages. Extreme care should be taken to protect against shock. Only trained personnel familiar with electronic equipment should install, start, or maintain this equipment.

⚠ WARNING

UNINTENDED START!

When the frequency converter is connected to AC mains, the motor may start at any time. The frequency converter, motor, and any driven equipment must be in operational readiness. Failure to be in operational readiness when the frequency converter is connected to AC mains could result in death, serious injury, equipment, or property damage.

Unintended Start

When the frequency converter is connected to the AC mains, the motor may be started by means of an external switch, a serial bus command, an input reference signal, or a cleared fault condition. Use appropriate cautions to guard against an unintended start.

⚠ WARNING

DISCHARGE TIME!

Frequency converters contain DC link capacitors that can remain charged even when AC mains is disconnected. To avoid electrical hazards, remove AC mains from the frequency converter and wait 20 minutes before doing any service or repair. Failure to wait the specified time after power has been removed prior to doing service or repair on the unit could result in death or serious injury.

2 Introduction

2.1 Exploded Views

2

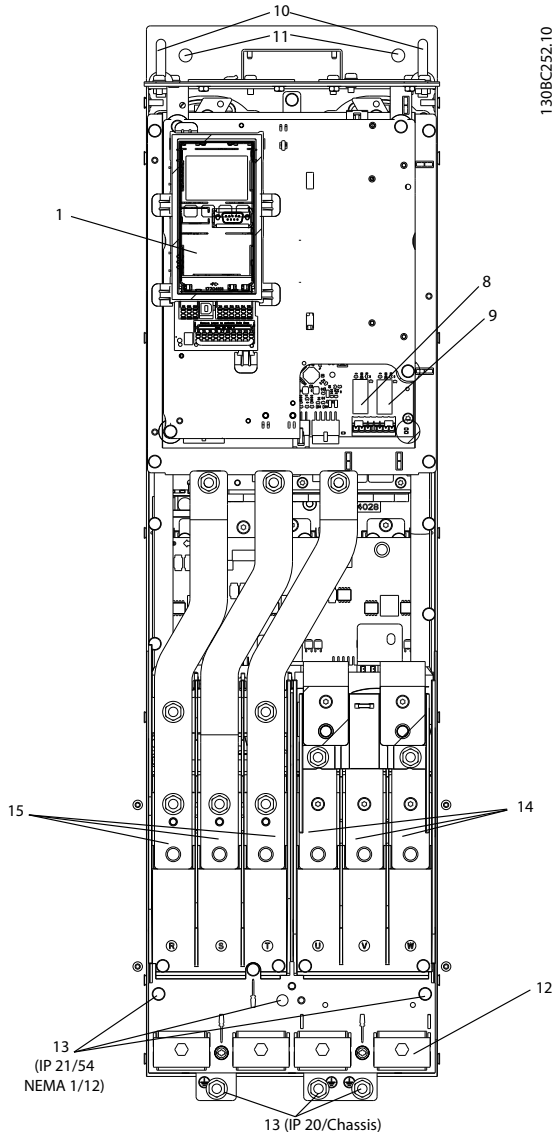

130BC252.10

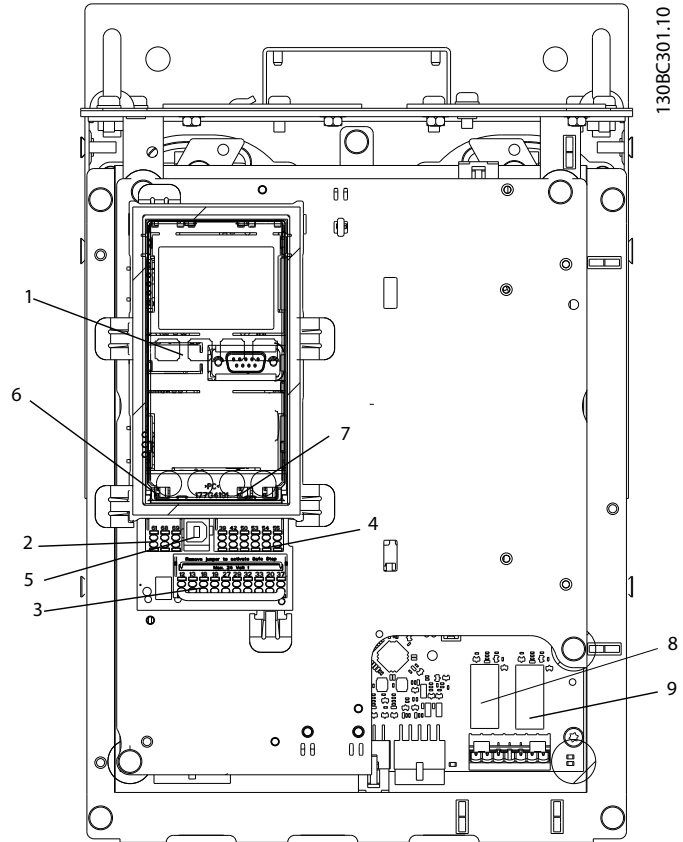

130BC301.10

Illustration 2.2 Close-up View: LCP and Control Functions

Illustration 2.1 D1 Interior Components

1	LCP (Local Control Panel)	9	Relay 2 (04, 05, 06)
2	RS-485 serial bus connector	10	Lifting ring
3	Digital I/O and 24 V power supply	11	Mounting slot
4	Analog I/O connector	12	Cable clamp (PE)
5	USB connector	13	Earth (ground)
6	Serial bus terminal switch	14	Motor output terminals 96 (U), 97 (V), 98 (W)
7	Analog switches (A53), (A54)	15	Mains input terminals 91 (L1), 92 (L2), 93 (L3)
8	Relay 1 (01, 02, 03)		

Table 2.1

2

2.2 Purpose of the Manual

This manual is intended to provide detailed information for the installation and start up of the frequency converter. provides requirements for mechanical and electrical installation, including input, motor, control and serial communications wiring, and control terminal functions. provides detailed procedures for start up, basic operational programming, and functional testing. The remaining chapters provide supplementary details. These details include user interface, detailed programming, application examples, start-up troubleshooting, and specifications.

2.3 Additional Resources

Other resources are available to understand advanced frequency converter functions and programming.

- The *VLT® Programming Guide* provides greater detail on working with parameters and many application examples.
- The *VLT® Design Guide* is intended to provide detailed capabilities and functionality to design motor control systems.
- Supplemental publications and manuals are available from Danfoss. See <http://www.danfoss.com/Products/Literature/Technical+Documentation.htm> for listings.
- Optional equipment is available that may change some of the procedures described. Reference the instructions supplied with those options for specific requirements. Contact the local Danfoss supplier or visit the Danfoss website for downloads or additional information.

2.4 Product Overview

A frequency converter is an electronic motor controller that converts AC mains input into a variable AC waveform output. The frequency and voltage of the output are regulated to control the motor speed or torque. The frequency converter can vary the speed of the motor in response to system feedback, such as position sensors on a conveyor belt. The frequency converter can also regulate the motor by responding to remote commands from external controllers.

In addition, the frequency converter monitors the system and motor status, issues warnings or alarms for fault conditions, starts and stops the motor, optimizes energy efficiency, and offers many more control, monitoring, and efficiency functions. Operation and monitoring functions are available as status indications to an outside control system or serial communication network.

2.5 Internal Controller Functions

Illustration 2.3 is a block diagram of the frequency converter's internal components. See Table 2.2 for their functions.

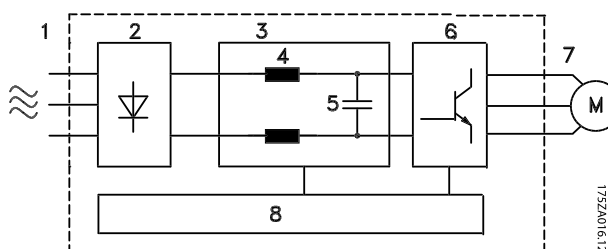

Illustration 2.3 Frequency Converter Block Diagram

Area	Title	Functions
1	Mains input	<ul style="list-style-type: none"> • Three-phase AC mains power supply to the frequency converter
2	Rectifier	<ul style="list-style-type: none"> • The rectifier bridge converts the AC input to DC voltage to supply inverter power
3	DC bus	<ul style="list-style-type: none"> • Intermediate DC-bus circuit handles the DC current
4	DC reactors	<ul style="list-style-type: none"> • Filter the intermediate DC circuit current • Provide line transient protection • Reduce RMS current • Raise the power factor reflected back to the line • Reduce harmonics on the AC input
5	Capacitor bank	<ul style="list-style-type: none"> • Stores the DC power • Provides ride-through protection for short power losses
6	Inverter	<ul style="list-style-type: none"> • Converts the DC into a controlled PWM AC waveform for a controlled variable output to the motor
7	Output to motor	<ul style="list-style-type: none"> • Regulated three-phase output power to the motor

Area	Title	Functions
8	Control circuitry	<ul style="list-style-type: none">• Input power, internal processing, output, and motor current are monitored to provide efficient operation and control• User interface and external commands are monitored and performed• Status output and control can be provided

Table 2.2 Frequency Converter Internal Components

3 Installation

3

3.1 Planning the Installation Site

CAUTION

Before performing the installation it is important to plan the installation of the frequency converter. Neglecting this may result in extra work during and after installation.

Select the best possible operation site by considering the following (see details on the following pages, and the respective Design Guides):

- Ambient operating temperature
- Installation method
- How to cool the unit
- Position of the frequency converter
- Cable routing
- Ensure the power source supplies the correct voltage and necessary current
- Ensure that the motor current rating is within the maximum current from the frequency converter
- If the frequency converter is without built-in fuses, ensure that the external fuses are rated correctly.

Voltage	Altitude Restrictions
380-480 V	At altitudes above 3 km, contact Danfoss regarding PELV
525-600 V	At altitudes above 2 km, contact Danfoss regarding PELV.

Table 3.1 Installation in High Altitudes

3.2 Pre-Installation Checklist

- Before unpacking the frequency converter, ensure the packaging is intact. If any damage has occurred, immediately contact the shipping company to claim the damage.
- Before unpacking the frequency converter, locate it as close as possible to the final installation site.
- Compare the model number on the nameplate to what was ordered to verify the proper equipment.
- Ensure each of the following are rated for the same voltage:
 - Mains (power)
 - Frequency converter
 - Motor

- Ensure that frequency converter output current rating is equal to or greater than motor full load current for peak motor performance.
 - Motor size and frequency converter power must match for proper overload protection.
 - If frequency converter rating is less than motor, full motor output cannot be achieved.

3.3 Mechanical Installation

3.3.1 Cooling

- Top and bottom clearance for air cooling must be provided. Generally, 225 mm (9 in) is required.
- Improper mounting can result in over heating and reduced performance
- Derating for temperatures starting between 45 °C (113 °F) and 50 °C (122 °F) and elevation 1000 m (3300 ft) above sea level must be considered. See *VLT@Design Guide* for detailed information.

The high power Danfoss VLT frequency converters utilize a back-channel cooling concept that removes heatsink cooling air, which carries approximately 90% of the heat out of the back channel of the frequency converters. The back-channel air can be redirected from the panel or room using one of the kits below.

NOTE

For ordering numbers, see the VLT High Power Drives Selection Guide, PB.56.B1.02.

Duct cooling

A back-channel cooling kit is available to direct the heatsink cooling air out of the panel when an IP20/chassis frequency converters is installed in a Rittal enclosure. Use of this kit reduces the heat in the panel and smaller door fans can be specified on the enclosure.

Cooling out the back (top and bottom covers)

The back channel cooling air can be ventilated out of the room so that the heat from the back channel is not dissipated into the control room.

A door fan(s) is required on the enclosure to remove the heat not contained in the backchannel of the frequency converters and any additional losses generated by other components inside the enclosure. The total required air flow must be calculated so that the appropriate fans can be selected.

Airflow

The necessary airflow over the heat sink must be secured. The flow rate is shown in *Table 3.2*.

The fan runs for the following reasons:

- AMA
- DC Hold
- Pre-Mag
- DC Brake
- 60% of nominal current is exceeded
- Specific heatsink temperature exceeded (power size dependent).
- Specific Power Card ambient temperature exceeded (power size dependent)
- Specific Control Card ambient temperature exceeded

Enclosure protection	Frame	Door fan(s)/top fan	Heatsink fan(s)
IP21/NEMA 1	D1 and D2	170 m ³ /hr (100 CFM)	765 m ³ /hr (450 CFM)
IP00/Chassis	D3 and D4	255 m ³ /hr (150 CFM)	765 m ³ /hr (450 CFM)

* Airflow per fan. Frame size F contains multiple fans.

Table 3.2 Airflow

3.3.2 Lifting

Always lift the frequency converter using the dedicated lifting eyes. Use a bar to avoid bending the lifting holes.

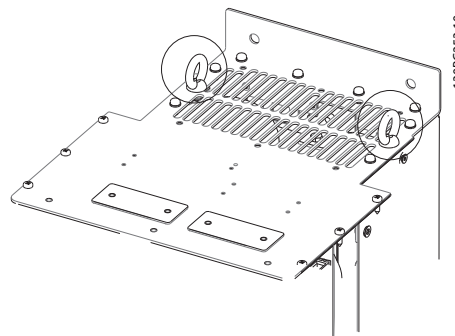

Illustration 3.1 Position Lifting Straps where Indicated

CAUTION

The angle from the top of the frequency converter to the lifting cables should be 60 ° or greater.

3.4 Electrical Installation

3.4.1 General Requirements

This section contains detailed instructions for wiring the frequency converter. The following tasks are described:

- Wiring the motor to the frequency converter output terminals
- Wiring the AC mains to the frequency converter input terminals
- Connecting control and serial communication wiring
- After power has been applied, checking input and motor power; programming control terminals for their intended functions

3

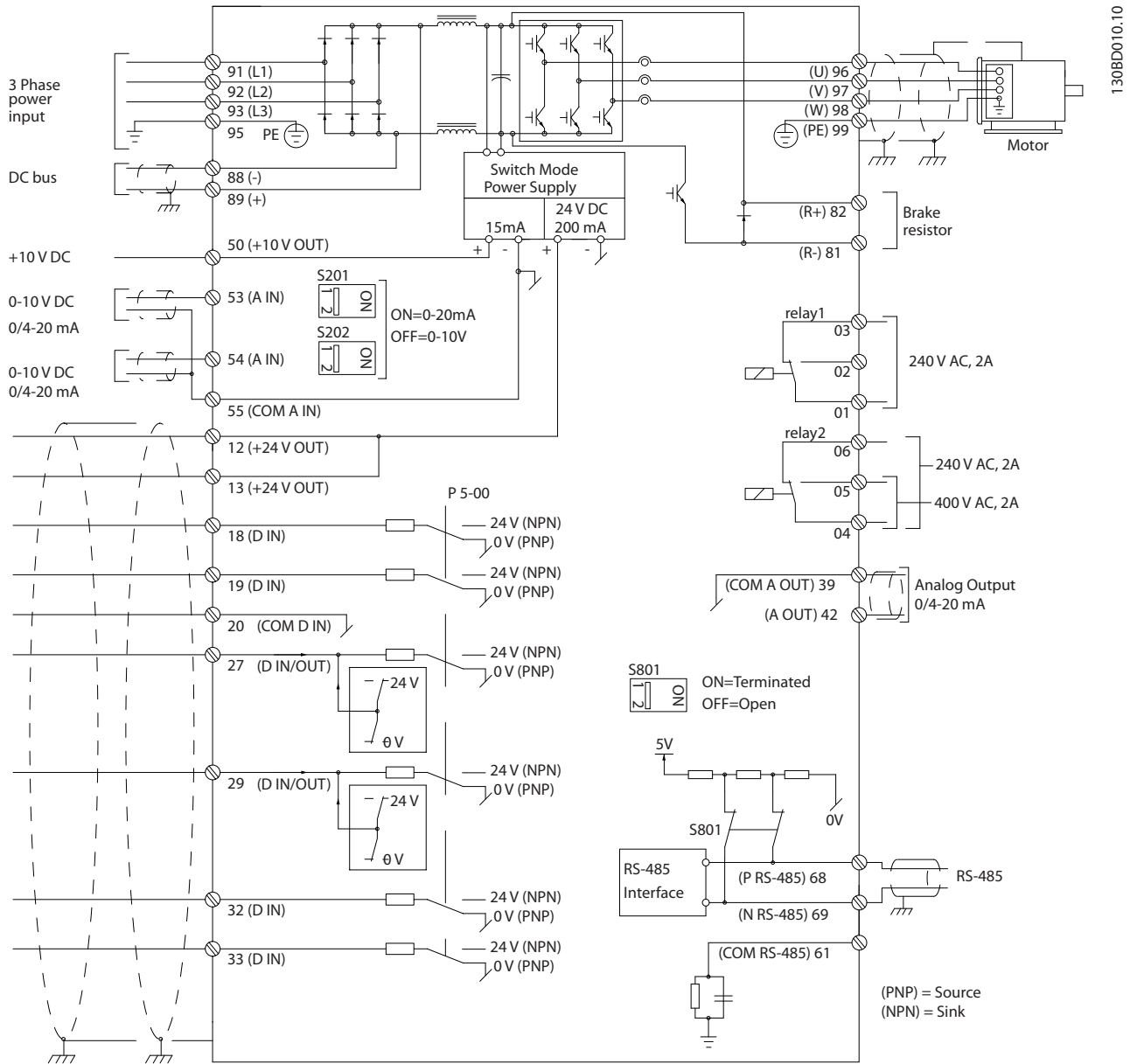

Illustration 3.2 Wiring Diagram

WARNING

EQUIPMENT HAZARD!

Rotating shafts and electrical equipment can be hazardous. All electrical work must conform to national and local electrical codes. It is strongly recommended that installation, start up, and maintenance be performed only by trained and qualified personnel. Failure to follow these guidelines could result in death or serious injury.

CAUTION

WIRING ISOLATION!

Run input power, motor wiring and control wiring in three separate metallic conduits or use separated shielded cable for high frequency noise isolation. Failure to isolate power, motor and control wiring could result in less than optimum frequency converter and associated equipment performance.

For personal safety, comply with the following requirements

- Electronic controls equipment is connected to hazardous mains voltage. Extreme care should be taken to protect against electrical hazards when applying power to the unit.
- Run motor cables from multiple frequency converters separately. Induced voltage from output motor cables run together can charge equipment capacitors even with the equipment turned off and locked out.
- Field wiring terminals are not intended to receive a conductor one size larger.

Overload and Equipment Protection

- An electronically activated function within the frequency converter provides overload protection for the motor. The overload calculates the level of increase to activate timing for the trip (controller output stop) function. The higher the current draw, the quicker the trip response. The overload provides Class 20 motor protection. See for details on the trip function.
- Because the motor wiring carries high frequency current, it is important that wiring for mains, motor power, and control are run separately. Use metallic conduit or separated shielded wire. See *Illustration 3.3*. Failure to isolate power, motor, and control wiring could result in less than optimum equipment performance.
- All frequency converters must be provided with short-circuit and over-current protection. Input fusing is required to provide this protection, see *Illustration 3.4*. If not factory supplied, fuses must be provided by the installer as part of installation. See maximum fuse ratings in 11.3.1 *Protection*.

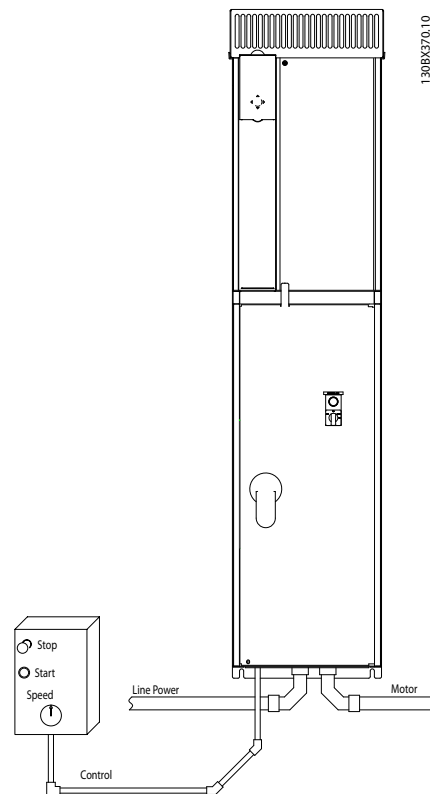

Illustration 3.3 Example of Proper Electrical Installation Using Conduit

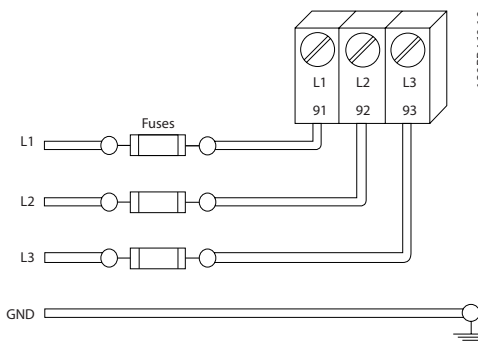

Illustration 3.4 Frequency Converter Fuses

Wire Type and Ratings

- All wiring must comply with local and national regulations regarding cross-section and ambient temperature requirements.
- Danfoss recommends that all power connections are made with a minimum 75 °C rated copper wire.

3.4.2 Earth (Ground) Requirements

⚠ WARNING

EARTHING (GROUNDING) HAZARD!

For operator safety, it is important to earth (ground) the frequency converter properly in accordance with national and local electrical codes as well as instructions contained within this document. Do not use conduit connected to the frequency converter as a replacement for proper grounding. Earth (ground) currents are higher than 3.5 mA. Failure to earth (ground) the frequency converter properly could result in death or serious injury. Earthing (grounding) hazard

NOTE

It is the responsibility of the user or certified electrical installer to ensure correct earthing (grounding) of the equipment in accordance with national and local electrical codes and standards.

- Follow all local and national electrical codes to earth (ground) electrical equipment properly.
- Proper protective earthing (grounding) for equipment with earth (ground) currents higher than 3.5 mA must be established, see 3.4.2.1 Leakage Current (>3.5 mA).
- A dedicated earth wire (ground wire) is required for input power, motor power and control wiring.
- Use the clamps provided with the equipment for proper earth connections (ground connections).
- Do not earth (ground) one frequency converter to another in a "daisy chain" fashion.
- Keep the earth (ground) wire connections as short as possible.
- Using high-strand wire to reduce electrical noise is recommended.
- Follow motor manufacturer wiring requirements.

3.4.2.1 Leakage Current (>3.5 mA)

Follow national and local codes regarding protective earthing of equipment with a leakage current > 3.5 mA. Frequency converter technology implies high frequency switching at high power. This will generate a leakage current in the earth connection. A fault current in the frequency converter at the output power terminals might contain a DC component, which can charge the filter capacitors and cause a transient earth current. The earth leakage current depends on various system configurations including RFI filtering, screened motor cables, and frequency converter power.

EN/IEC61800-5-1 (Power Drive System Product Standard) requires special care if the leakage current exceeds 3.5 mA.

Earthing (grounding) must be reinforced in one of the following ways:

- Earth (ground) wire of at least 10 mm²
- Two separate earth (ground) wires both complying with the dimensioning rules.

See EN 60364-5-54 § 543.7 for further information.

Using RCDs

Where residual current devices (RCDs)—also known as earth leakage circuit breakers (ELCBs)—are used, comply with the following: residual current devices (RCDs)

- Use RCDs of type B only, which are capable of detecting AC and DC currents.
- Use RCDs with an inrush delay to prevent faults due to transient earth currents.
- Dimension RCDs according to the system configuration and environmental considerations.

3.4.2.2 Earthing (Grounding) IP20 Enclosures

The frequency converter can be earthed (grounded) using conduit or shielded cable. For earthing (grounding) of the power connections, use the dedicated earthing (grounding) points as shown in *Illustration 3.6*.

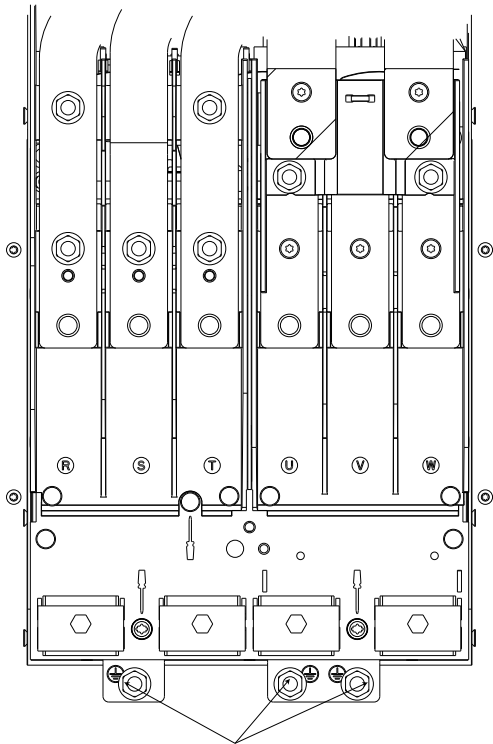

Illustration 3.5 Earthing (Grounding) Points for IP20 (Chassis) Enclosures

3.4.2.3 Earthing (Grounding) IP21/54 Enclosures

The frequency converter can be earthed (grounded) using conduit or shielded cable. For earthing (grounding) of the power connections, use the dedicated earthing (grounding) points as shown in *Illustration 3.6*.

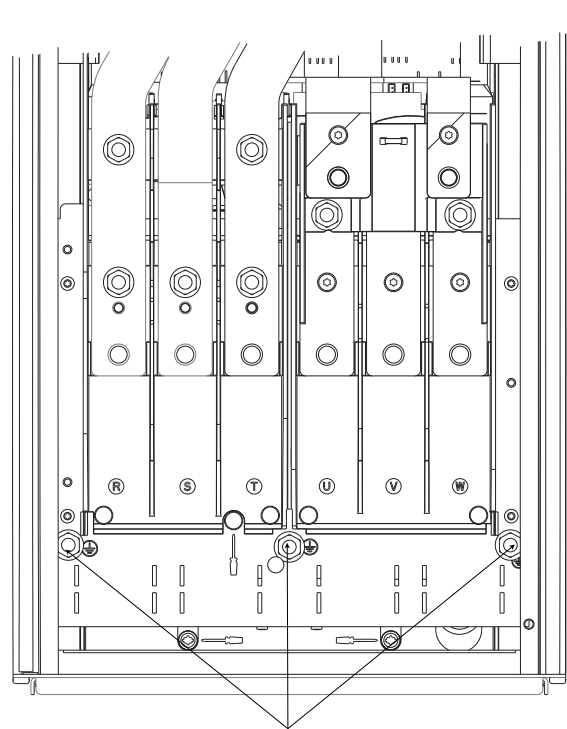

Illustration 3.6 Earthing (Grounding) for IP21/54 Enclosures.

3.4.3 Motor Connection

! WARNING

INDUCED VOLTAGE!

Run output motor cables from multiple frequency converters separately. Induced voltage from output motor cables run together can charge equipment capacitors even with the equipment turned off and locked out. Failure to run output motor cables separately could result in death or serious injury.

- For maximum cable sizes, see 11.2 Mains Supply.
- Comply with local and national electrical codes for cable sizes.
- Gland plates are provided at the base of IP21/54 and higher (NEMA1/12) units.

- Do not install power factor correction capacitors between the frequency converter and the motor.
- Do not wire a starting or pole-changing device between the frequency converter and the motor.
- Connect the 3-phase motor wiring to terminals 96 (U), 97 (V), and 98 (W).
- Earth (ground) the cable in accordance with the instructions provided.
- Torque terminals in accordance with the information provided in 11.3.4 Connection Tightening Torques
- Follow motor manufacturer wiring requirements.

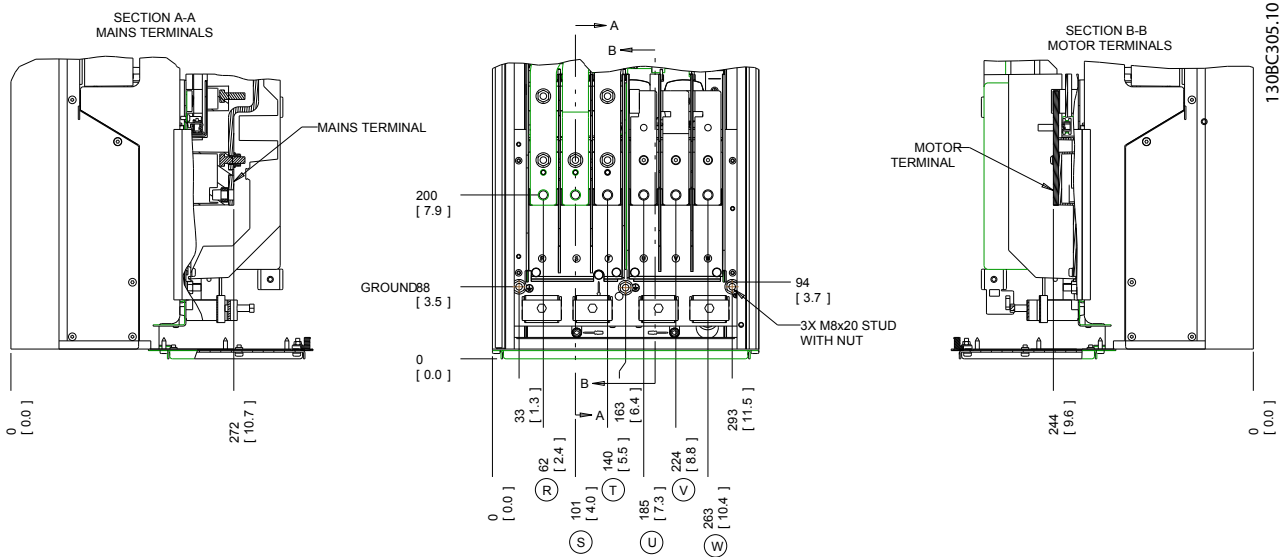

Illustration 3.7 Terminal Locations D1h

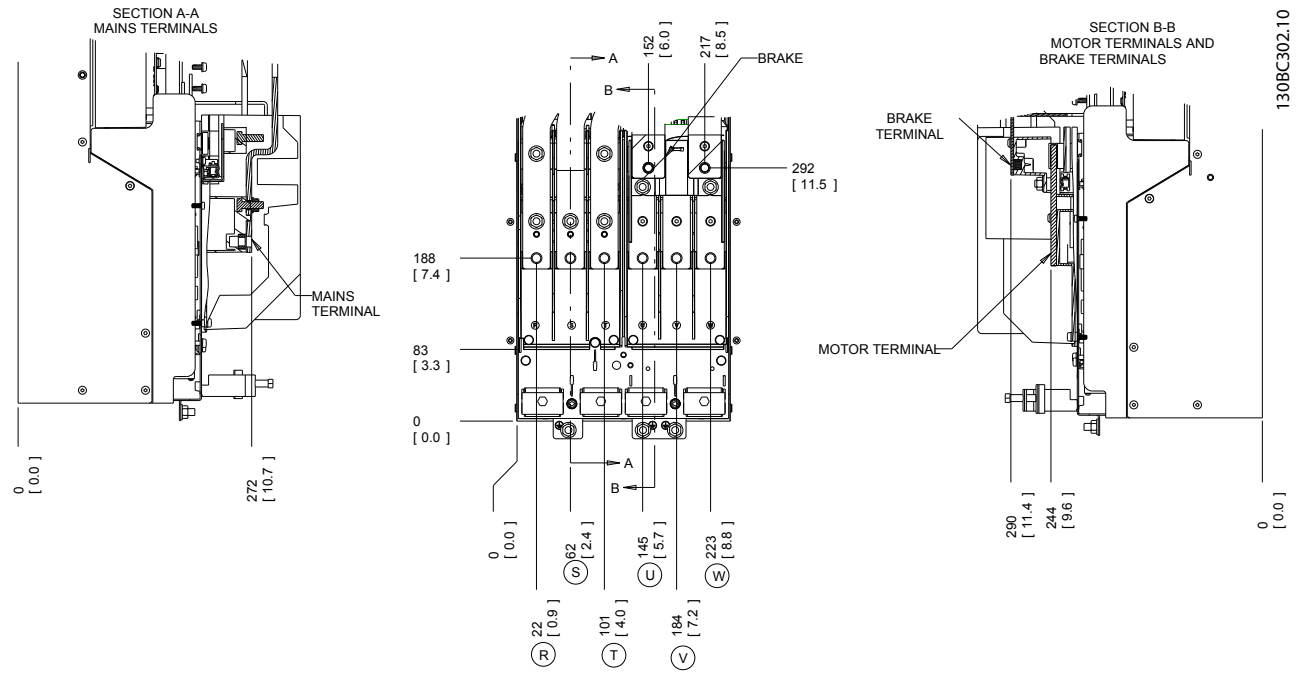

Illustration 3.8 Terminal Locations D3h

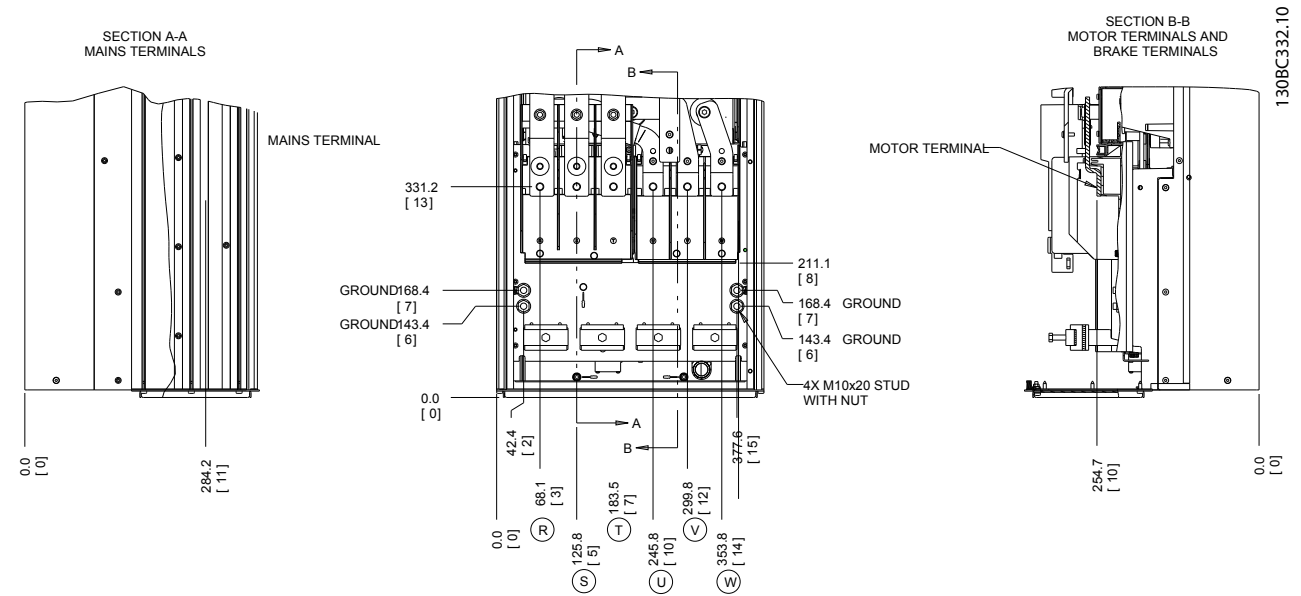

Illustration 3.9 Terminal Locations D2h

3

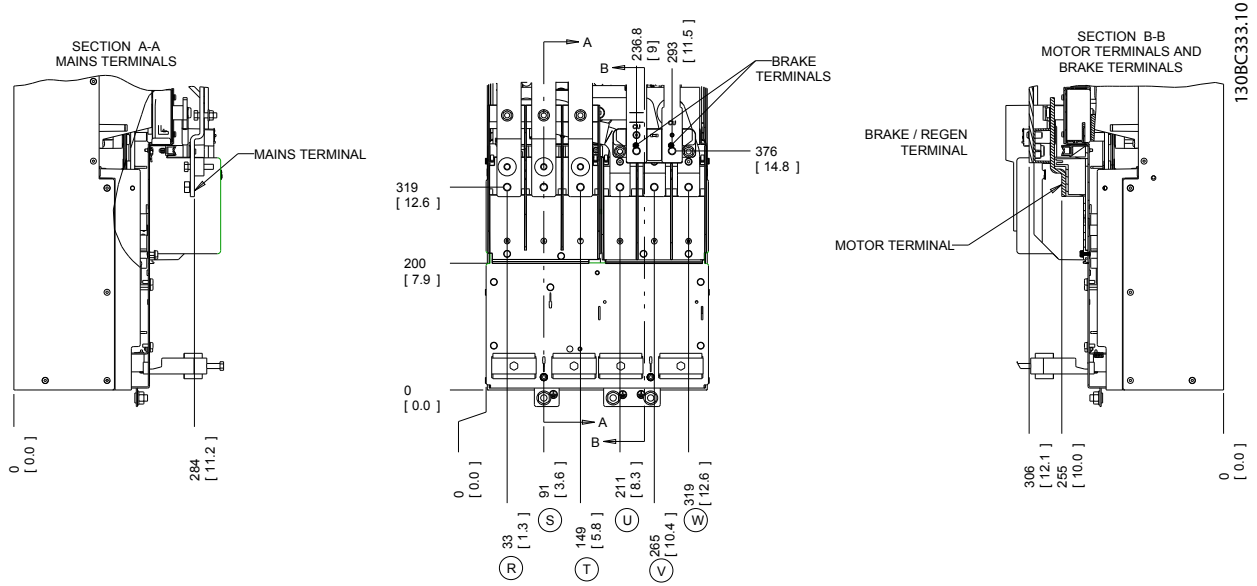

Illustration 3.10 Terminal Locations D4h

3.4.3.1 Motor Cable

The motor must be connected to terminals U/T1/96, V/ T2/97, W/T3/98. Earth (ground) to terminal 99. All types of three-phase asynchronous standard motors can be used with a frequency converter unit. The factory setting is for clockwise rotation with the frequency converter output connected as follows:

Terminal No.	Function
96, 97, 98, 99	Mains U/T1, V/T2, W/T3 Earth (ground)

Table 3.3

3.4.3.2 Motor Rotation Check

The direction of rotation can be changed by switching two phases in the motor cable or by changing the setting of 4-10 Motor Speed Direction.

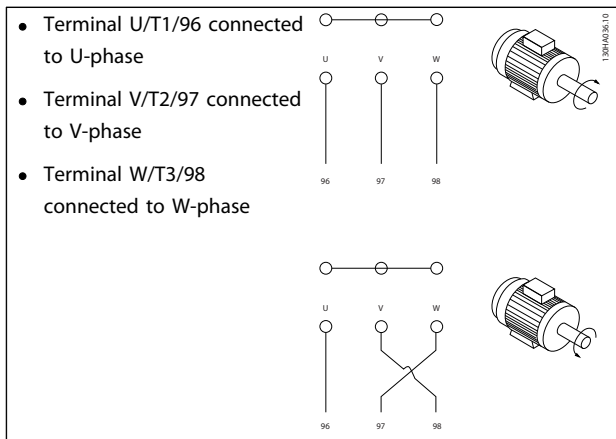

Table 3.4

A motor rotation check can be performed using 1-28 Motor Rotation Check and following the steps shown in the display.

3.4.4 AC Mains Input Connection

- Size wiring is based upon the input current of the frequency converter.
- Comply with local and national electrical codes for cable sizes.
- Connect 3-phase AC input power wiring to terminals L1, L2, and L3 (see *Illustration 3.11*).

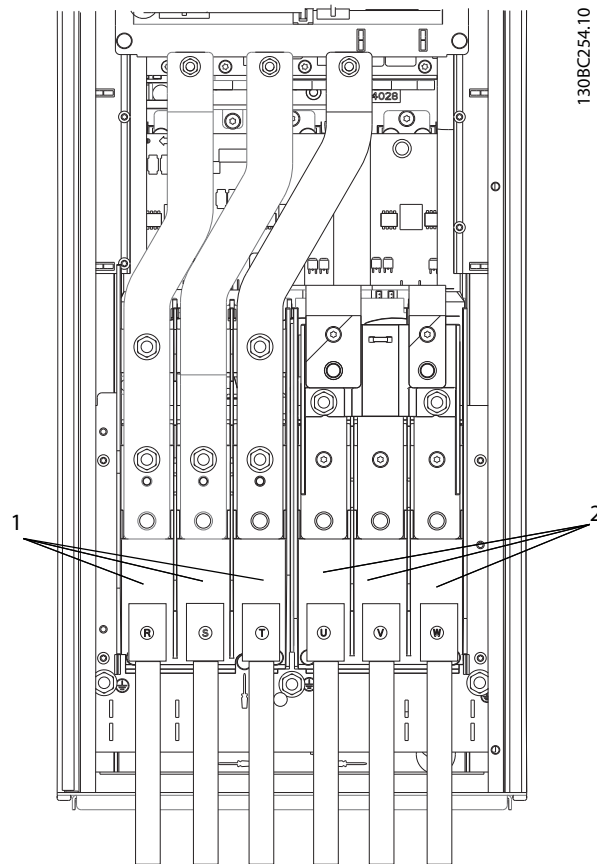

Illustration 3.11 Connecting to AC Mains

1	Mains connection
2	Motor connection

Table 3.5

- Earth (ground) the cable in accordance with the instructions provided.
- All frequency converters may be used with an isolated input source as well as with earth (ground) reference power lines. When supplied from an isolated mains source (IT mains or floating delta) or TT/TN-S mains with a grounded leg (grounded delta), set 14-50 RFI Filter to OFF. When off, the internal RFI filter capacitors between the chassis and the intermediate circuit are isolated to avoid damage to the intermediate circuit and to reduce earth (ground) capacity currents in accordance with IEC 61800-3.

3.5 Control Wiring Connection

- Isolate control wiring from high power components in the frequency converter.
- If the frequency converter is connected to a thermistor, for PELV isolation, optional thermistor control wiring must be reinforced/double insulated. A 24 V DC supply voltage is recommended.

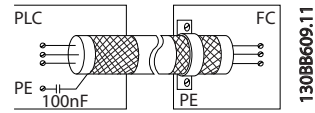

Illustration 3.13

Avoid EMC noise on serial communication

This terminal is connected to earth (ground) via an internal RC link. Use twisted-pair cables to reduce interference between conductors. The recommended method is shown below:

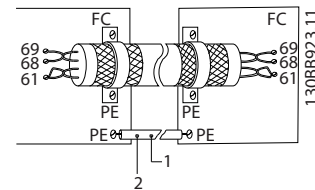

Illustration 3.14

1	Min. 16 mm ²
2	Equalizing cable

Table 3.7

Alternatively, the connection to terminal 61 can be omitted:

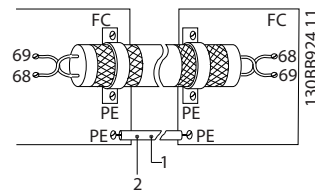

Illustration 3.15

1	Min. 16 mm ²
2	Equalizing cable

Table 3.8

3.5.1 Access

All terminals to the control cables are located underneath the LCP on the inside of the frequency converter. To access, open the door (IP21/54) or remove the front panel (IP20).

3.5.2 Using Screened Control Cables

Danfoss recommends braided screened/armoured cables to optimise EMC immunity of the control cables and the EMC emission from the motor cables.

3.5.3 Earthing (Grounding) of Screened Control Cables

Correct screening

The preferred method in most cases is to secure control and serial communication cables with screening clamps provided at both ends to ensure best possible high frequency cable contact. If the earth (ground) potential between the frequency converter and the PLC is different, electric noise may occur that will disturb the entire system. Solve this problem by fitting an equalizing cable next to the control cable. Minimum cable cross section: 16 mm².

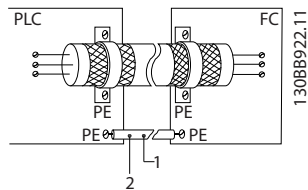

Illustration 3.12

1	Min. 16 mm ²
2	Equalizing cable

Table 3.6

50/60 Hz earth (ground) loops

With very long control cables, earth loops (ground loops) may occur. To eliminate earth (ground) loops, connect one end of the screen-to-earth (ground) with a 100 nF capacitor (keeping leads short).

3.5.4 Control Terminal Types

Terminal functions and default settings are summarized in 3.5.6 *Control Terminal Functions*.

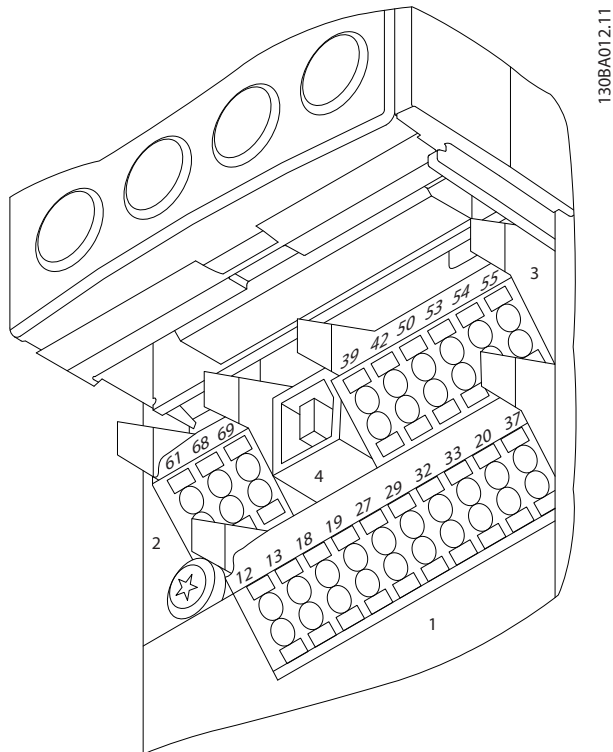

Illustration 3.16 Control Terminal Locations

- **Connector 1** provides four programmable digital input terminals, two additional digital terminals programmable as either input or output, a 24 V DC terminal supply voltage, and a common for optional customer supplied 24 V DC voltage.
- **Connector 2** terminals (+)68 and (-)69 are for an RS-485 serial communications connection.
- **Connector 3** provides two analog inputs, one analog output, 10 V DC supply voltage, and commons for the inputs and output.
- **Connector 4** is a USB port available for use with the MCT 10 Set-up Software.
- Also provided are two Form C relay outputs that are in various locations depending upon the frequency converter configuration and size.
- Some options available for ordering with the unit may provide additional terminals. See the manual provided with the equipment option.

3.5.5 Wiring to Control Terminals

Terminal plugs can be removed for easy access.

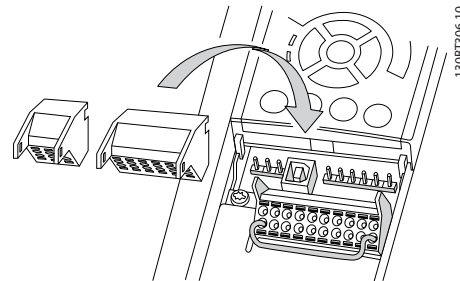

Illustration 3.17

3.5.6 Control Terminal Functions

Frequency converter functions are commanded by receiving control input signals.

- Each terminal must be programmed for the function it will be supporting in the parameters associated with that terminal. See and for terminals and associated parameters.
- It is important to confirm that the control terminal is programmed for the correct function. See for details on accessing parameters and programming.
- The default terminal programming is intended to initiate frequency converter functioning in a typical operational mode.

3.6 Serial Communication

RS-485 is a two-wire bus interface compatible with multi-drop network topology, i.e. nodes can be connected as a bus, or via drop cables from a common trunk line. A total of 32 nodes can be connected to one network segment. Repeaters divide network segments. Each repeater functions as a node within the segment in which it is installed. Each node connected within a given network must have a unique node address across all segments. Terminate each segment at both ends, using either the termination switch (S801) of the frequency converter or a biased termination resistor network. Always use screened twisted pair (STP) cable for bus cabling, and always follow good common installation practice. Low-impedance earth (ground) connection of the screen at every node is important, including at high frequencies. Thus, connect a large surface of the screen to earth (ground), for example with a cable clamp or a conductive cable gland. It may be necessary to apply potential-equalizing cables to maintain the same earth (ground)

potential throughout the network. Particularly in installations with long cables.

To prevent impedance mismatch, always use the same type of cable throughout the entire network. When connecting a motor to the frequency converter, always use screened motor cable.

3

Cable	Screened twisted pair (STP)
Impedance	120 Ω
Max. cable length	1200 m (including drop lines) 500 m station-to-station

Table 3.9

4 Start Up and Functional Test

4.1 Pre-start

CAUTION

Before applying power to the unit, inspect the entire installation as detailed in *Table 4.1*. Check mark those items when completed.

4

Inspect for	Description	☑
Auxiliary equipment	<ul style="list-style-type: none"> Look for auxiliary equipment, switches, disconnects, or input fuses/circuit breakers that may reside on the input power side of the frequency converter or output side to the motor. Ensure that they are ready for full speed operation. Check function and installation of any sensors used for feedback to the frequency converter. Remove power factor correction caps on motor(s), if present. 	
Cable routing	<ul style="list-style-type: none"> Ensure that input power, motor wiring, and control wiring are separated or in three separate metallic conduits for high frequency noise isolation. 	
Control wiring	<ul style="list-style-type: none"> Check for broken or damaged wires and loose connections. Check that control wiring is isolated from power and motor wiring for noise immunity. Check the voltage source of the signals, if necessary. The use of shielded cable or twisted pair is recommended. Ensure that the shield is terminated correctly. 	
Cooling clearance	<ul style="list-style-type: none"> Measure that top and bottom clearance is adequate to ensure proper air flow for cooling. 	
EMC considerations	<ul style="list-style-type: none"> Check for proper installation regarding electromagnetic compatibility. 	
Environmental considerations	<ul style="list-style-type: none"> See equipment label for the maximum ambient operating temperature limits. Humidity levels must be 5-95% non-condensing. 	
Fusing and circuit breakers	<ul style="list-style-type: none"> Check for proper fusing or circuit breakers. Check that all fuses are inserted firmly and in operational condition and that all circuit breakers are in the open position. 	
Earthing (Grounding)	<ul style="list-style-type: none"> The unit requires an earth wire(ground wire) from its chassis to the building earth (ground). Check for good earth connections(ground connections) that are tight and free of oxidation. Earthing (grounding) to conduit or mounting the back panel to a metal surface is not a suitable earth (ground). 	
Input and output power wiring	<ul style="list-style-type: none"> Check for loose connections. Check that motor and mains are in separate conduit or separated screened cables. 	
Panel interior	<ul style="list-style-type: none"> Inspect that the unit interior is free of dirt, metal chips, moisture, and corrosion. 	
Switches	<ul style="list-style-type: none"> Ensure that all switch and disconnect settings are in the proper positions. 	
Vibration	<ul style="list-style-type: none"> Check that the unit is mounted solidly or that shock mounts are used, as necessary. Check for an unusual amount of vibration. 	

Table 4.1 Start Up Check List

4.2 Applying Power to the Frequency Converter

⚠ WARNING

HIGH VOLTAGE!

Frequency converters contain high voltage when connected to AC mains. Installation, start-up and maintenance should be performed by qualified personnel only. Failure to perform installation, start-up and maintenance by qualified personnel could result in death or serious injury.

⚠ WARNING

UNINTENDED START!

When the frequency converter is connected to AC mains, the motor may start at any time. The frequency converter, motor, and any driven equipment must be in operational readiness. Failure to be in operational readiness when the frequency converter is connected to AC mains could result in death, serious injury, equipment, or property damage.

1. Confirm input voltage is balanced within 3%. If not, correct input voltage imbalance before proceeding. Repeat procedure after voltage correction.
2. Ensure optional equipment wiring, if present, matches installation application.
3. Ensure that all operator devices are in the OFF position. Panel doors closed or cover mounted.
4. Apply power to the unit. DO NOT start the frequency converter at this time. For units with a disconnect switch, turn to the ON position to apply power to the frequency converter.

NOTE

If the status line at the bottom of the LCP reads **AUTO REMOTE COAST**, this indicates that the unit is ready to operate but is missing an input signal on terminal 27.

4.3 Basic Operational Programming

4.3.1 Set-up Wizard

The built-in "wizard" menu guides the installer through the set-up of the frequency converter in a clear and structured manner, and has been constructed with reference to the industries refrigeration engineers, to ensure that the text and language used makes complete sense to the installer.

At start-up the FC 103 asks the user run the VLT Drive Application Guide or to skip it (until it has been run, the FC 103 will ask every time at start-up), thereafter in the

event of power failure the application guide is accessed through the Quick menu screen.

If [Cancel] is pressed, the FC 103 will return to the status screen. An automatic timer will cancel the wizard after 5 min. of inactivity (no keys pressed). The wizard must be re-entered through the Quick Menu when it has been run once.

Answering the questions on the screens takes the user through a complete set-up for the FC 103. Most standard refrigeration applications can be setup by using this Application Guide. Advanced features must be accessed through the menu structure (Quick Menu or Main Menu) in the frequency converter.

The FC 103 Wizard covers all standard settings for:

- Compressors
- Single fan and pump
- Condenser fans

These applications are then further expanded to allow control of the frequency converter to be controlled via the frequency converter's own internal PID controllers or from an external control signal.

After completing set-up, choose to re-run wizard or start application

The Application Guide can be cancelled at any time by pressing [Back]. The Application Guide can be re-entered through the Quick Menu. When re-entering the Application Guide, the user will be asked to keep previous changes to the factory set-up or to restore default values.

The FC 103 will start up initially with the Application guide thereafter in the event of power failure the application guide is accessed through the Quick menu screen. The following screen will be presented:

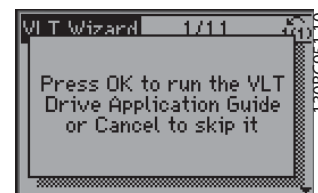

Illustration 4.1

If [Cancel] is pressed, the FC 103 will return to the status screen. An automatic timer will cancel the wizard after 5 min. of inactivity (no keys pressed). The wizard must be re-entered through the Quick Menu as described below.

If [OK] is pressed, the Application Guide will start with the following screen:

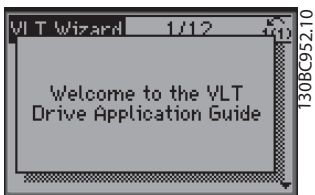

Illustration 4.2

NOTE

Numbering of steps in wizard (e.g. 1/12) can change depending on choices in the workflow.

This screen will automatically change to the first input screen of the Application Guide:



Illustration 4.3



Illustration 4.4

Compressor pack set-up

As an example, see screens below for a compressor pack set-up:

Voltage and frequency set-up

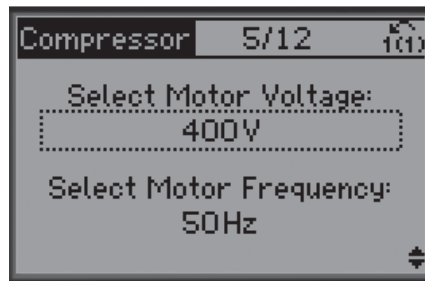

Illustration 4.5

Current and nominal speed set-up



Illustration 4.6

Min. and max. frequency set-up



Illustration 4.7

Min. time between two starts

4



130BA791.10

Illustration 4.8

Choose with/without bypass valve

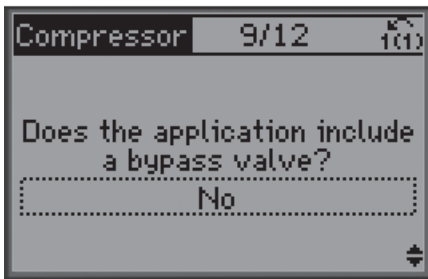

130BA792.10

Illustration 4.9

Select open or closed loop

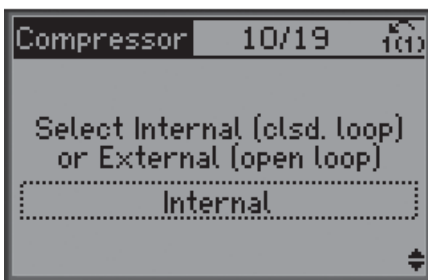

130BA793.10

Illustration 4.10

NOTE

Internal/Closed loop: The FC 103 will control the application directly using the internal PID control within the frequency converter and needs an input from an external input such as a temperature or other sensor which is wired directly into the frequency converter and controls from the sensor signal.

External/Open loop: The FC 103 takes its control signal from another controller (such as a pack controller) which gives the frequency converter e.g. 0-10 V, 4-20 mA or FC 103 Lon. The frequency converter will change its speed depending upon this reference signal.

Select sensor type

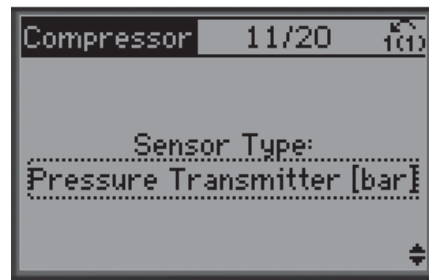

130BA794.10

Illustration 4.11

Settings for sensor



130BA795.10

Illustration 4.12

Info: 4-20 mA feedback chosen - connect accordingly

Select fixed or floating setpoint

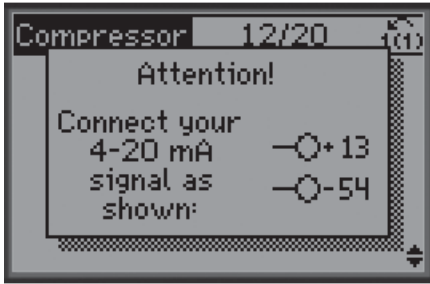

130BA796.10

Illustration 4.13



130BA799.10

Illustration 4.16

Info: Set switch accordingly

Set setpoint



130BA797.10

Illustration 4.14

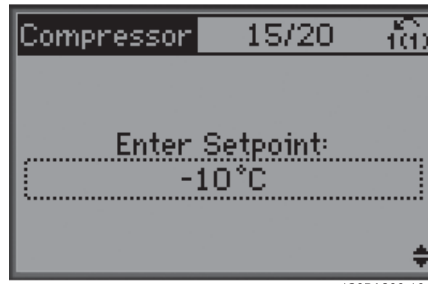

130BA800.10

Illustration 4.17

Select unit and conversion from pressure

Set high/low limit for setpoint



130BA798.10

Illustration 4.15

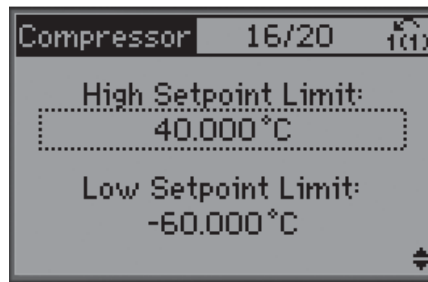

130BA801.10

Illustration 4.18

4

Set cut out/in value

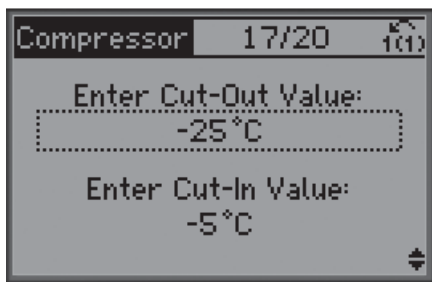

130BA802.10

Illustration 4.19

Choose pack control set-up

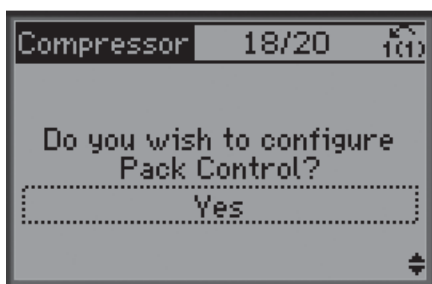

130BA803.10

Illustration 4.20

Set number of compressors in pack

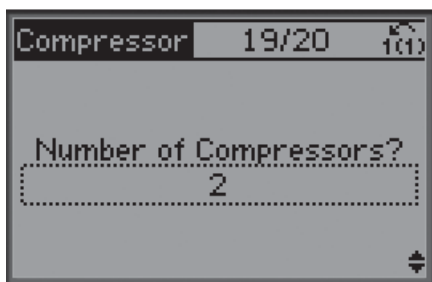

130BA804.10

Illustration 4.21

Info: Connect accordingly



130BC955.10

Illustration 4.22

Info: Setup completed



130BA806.10

Illustration 4.23

After completing set-up, choose to re-run wizard or start application. Select between the following options:

- Re-run wizard
- Go to main menu
- Go to status
- Run AMA - Note this is a reduced AMA if compressor application is selected and full AMA if single fan and pump is selected.
- If condenser fan is selected in application NO AMA can be run.
- Run application- this mode starts the frequency converter in either hand/local mode or via an external control signal if open loop is selected in an earlier screen

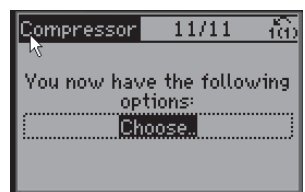

130BP956.10

Illustration 4.24

The Application Guide can be cancelled at any time by pressing [Back]. The Application Guide can be re-entered through the Quick Menu:

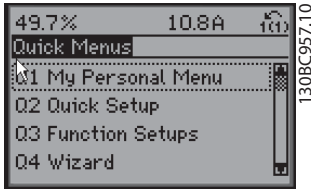

Illustration 4.25

When re-entering the Application Guide, select between previous changes to the factory set-up or restore default values.

NOTE

If the system requirement is to have the internal pack controller for 3 compressors plus by-pass valve connected, there is the need to specify FC 103 with the extra relay card (MCB 105) mounted inside the frequency converter. The bypass valve must be programmed to operate from one of the extra relay outputs on the MCB 105 board. This is needed because the standard relay outputs in the FC 103 are used to control the compressors in the pack.

4.3.2 Required Initial Frequency Converter Programming

NOTE

If the wizard is run, ignore the following.

Frequency converters require basic operational programming before running for best performance. Basic operational programming requires entering motor-nameplate data for the motor being operated and the minimum and maximum motor speeds. Enter data in accordance with the following procedure. Parameter settings recommended are intended for start up and checkout purposes. Application settings may vary. See for detailed instructions on entering data through the LCP.

Enter data with power ON, but before operating the frequency converter.

1. Press [Main Menu] twice on the LCP.
2. Use the navigation keys to scroll to parameter group 0-** Operation/Display and press [OK].

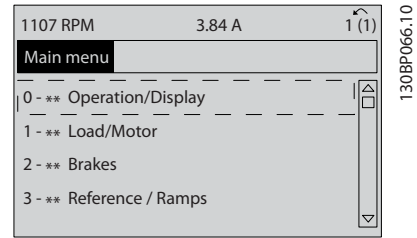

Illustration 4.26

3. Use navigation keys to scroll to parameter group 0-0* Basic Settings and press [OK].

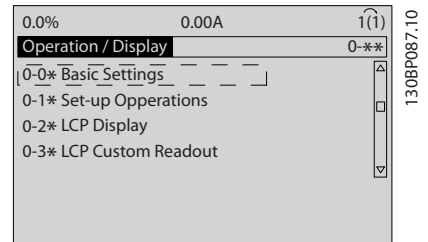

Illustration 4.27

4. Use navigation keys to scroll to 0-03 Regional Settings and press [OK].

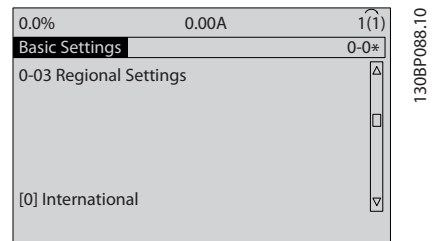
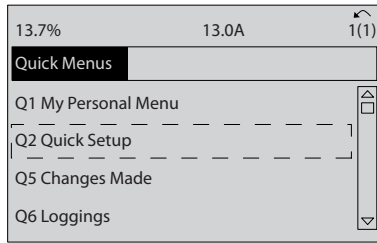

Illustration 4.28

5. Use navigation keys to select [0] International or [1] North America as appropriate and press [OK]. (This changes the default settings for a number of basic parameters. See 6.4 International/North American Default Parameter Settings for a complete list.)
6. Press [Quick Menu] on the LCP.
7. Use the navigation keys to scroll to parameter group Q2 Quick Setup and press [OK].

4



130B8847.10

Illustration 4.29

- Select language and press [OK]. Then enter the motor data in parameters 1-20/1-21 through 1-25. The information can be found on the motor nameplate.

1-20 Motor Power [kW] or 1-21 Motor Power [HP]

1-22 Motor Voltage

1-23 Motor Frequency

1-24 Motor Current

1-25 Motor Nominal Speed

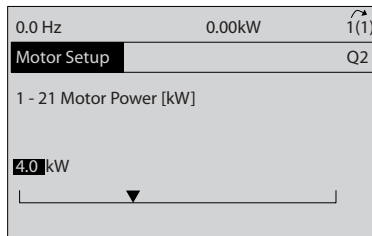

130B1772.10

Illustration 4.30

- A jumper wire should be in place between control terminals 12 and 27. If this is the case, leave *5-12 Terminal 27 Digital Input* at factory default. Otherwise select *No Operation*. For frequency converters with an optional Danfoss bypass, no jumper wire is required.
- 3-02 Minimum Reference*
- 3-03 Maximum Reference*
- 3-41 Ramp 1 Ramp Up Time*
- 3-42 Ramp 1 Ramp Down Time*
- 3-13 Reference Site*. Linked to Hand/Auto* Local Remote.

This concludes the quick set-up procedure. Press [Status] to return to the operational display.

4.4 Local-control Test

CAUTION

MOTOR START!

Ensure that the motor, system and any attached equipment are ready for start. It is the responsibility of the user to ensure safe operation under any condition. Failure to ensure that the motor, system, and any attached equipment is ready for start could result in personal injury or equipment damage.

NOTE

The [Hand On] key provides a local start command to the frequency converter. The [Off] key provides the stop function.

When operating in local mode, [▲] and [▼] increase and decrease the speed output of the frequency converter. [←] and [→] move the display cursor in the numeric display.

- Press [Hand On].
- Accelerate the frequency converter by pressing [▲] to full speed. Moving the cursor left of the decimal point provides quicker input changes.
- Note any acceleration problems.
- Press [Off].
- Note any deceleration problems.

If acceleration problems were encountered

- If warnings or alarms occur, see .
- Check that motor data is entered correctly.
- Increase the ramp-up time in *3-41 Ramp 1 Ramp Up Time*.
- Increase current limit in *4-18 Current Limit*.
- Increase torque limit in *4-16 Torque Limit Motor Mode*.

If deceleration problems were encountered

- If warnings or alarms occur, see .
- Check that motor data is entered correctly.
- Increase the ramp-down time in *3-42 Ramp 1 Ramp Down Time*.
- Enable overvoltage control in *2-17 Over-voltage Control*.

See *5.1.1 Local Control Panel* for resetting the frequency converter after a trip.

NOTE

4.2 *Applying Power to the Frequency Converter* through in this chapter concludes the procedures for applying power to the frequency converter, basic programming, set-up, and functional testing.

4.5 System Start Up

The procedure in this section requires user-wiring and application programming to be completed. See for application set-up information. The following procedure is recommended after application set-up by the user is completed.

⚠ CAUTION

MOTOR START!

Ensure that the motor, system, and any attached equipment is ready for start. It is the responsibility of the user to ensure safe operation under any condition. Failure to do so could result in personal injury or equipment damage.

1. Press [Auto On].
2. Ensure that external control functions are properly wired to the frequency converter and all programming is completed.
3. Apply an external run command.
4. Adjust the speed reference throughout the speed range.
5. Remove the external run command.
6. Note any problems.

If warnings or alarms occur, see *9 Warnings and Alarms*.

5 User Interface

5.1 Local Control Panel

The local control panel (LCP) is the combined display and keypad on the front of the unit. The LCP is the user interface to the frequency converter.

The LCP has several user functions.

- Start, stop, and control speed when in local control.
- Display operational data, status, warnings and cautions.
- Programming frequency converter functions.
- Manually reset the frequency converter after a fault when auto-reset is inactive.

5.1.1 LCP Layout

The LCP is divided into four functional groups (see *Illustration 5.1*).

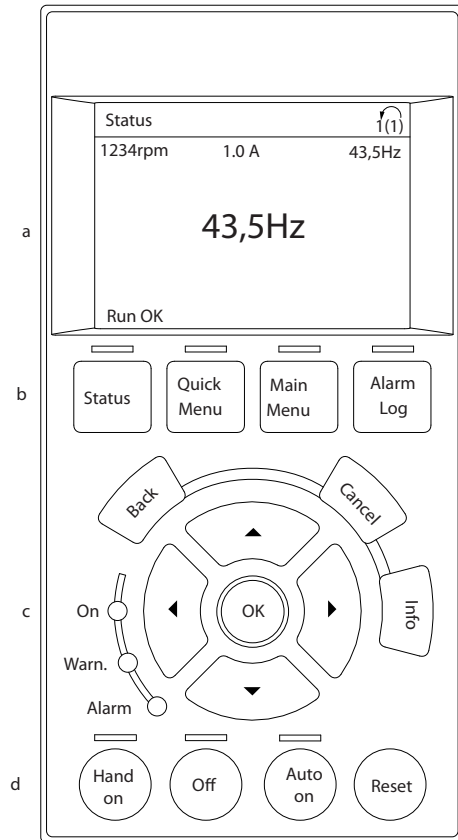

130BC362.10

Illustration 5.1 LCP

- Display area.
- Display menu keys for changing the display to show status options, programming, or error message history.
- Navigation keys for programming functions, moving the display cursor, and speed control in local operation. Also included are the status indicator lights.
- Operational mode keys and reset.

5.1.2 Setting LCP Display Values

The display area is activated when the frequency converter receives power from mains voltage, a DC bus terminal, or an external 24 V supply.

The information displayed on the LCP can be customized for user application.

- Each display readout has a parameter associated with it.
- Options are selected in the quick menu Q3-13 *Display Settings*.
- Display 2 has an alternate larger display option.
- The frequency converter status at the bottom line of the display is generated automatically and is not selectable.

Display	Parameter number	Default setting
1.1	0-20	Motor RPMs
1.2	0-21	Motor current
1.3	0-22	Motor power (kW)
2	0-23	Motor frequency
3	0-24	Reference in percent

Table 5.1

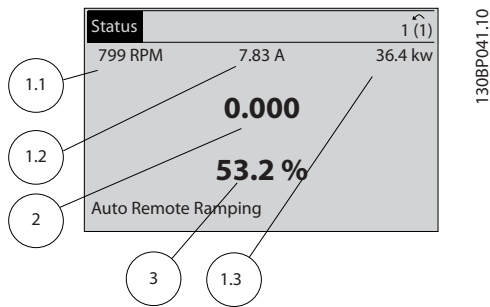

Illustration 5.2

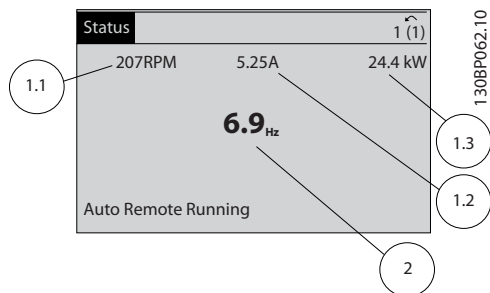

Illustration 5.3

5.1.3 Display

Menu keys are used for menu access for parameter set-up, toggling through status display modes during normal operation, and viewing fault log data.

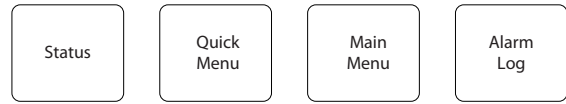

Illustration 5.4

Key	Function
Status	Shows operational information. <ul style="list-style-type: none"> • In Auto mode, press to toggle between status read-out displays • Press repeatedly to scroll through each status display • Press [Status] plus [▲] or [▼] to adjust the display brightness • The symbol in the upper right corner of the display shows the direction of motor rotation and which set-up is active. This is not programmable.
Quick Menu	Allows access to programming parameters for initial set up instructions and many detailed application instructions. <ul style="list-style-type: none"> • Press to access Q2 <i>Quick Setup</i> for sequenced instructions to program the basic frequency controller set up • Follow the sequence of parameters as presented for the function set up
Main Menu	Allows access to all programming parameters. <ul style="list-style-type: none"> • Press twice to access top-level index • Press once to return to the last location accessed • Press to enter a parameter number for direct access to that parameter
Alarm Log	Displays a list of current warnings, the last 10 alarms, and the maintenance log. <ul style="list-style-type: none"> • For details about the frequency converter before it entered the alarm mode, select the alarm number using the navigation keys and press [OK].

Table 5.2

5.1.4 Navigation Keys

Navigation keys are used for programming functions and moving the display cursor. The navigation keys also provide speed control in local (hand) operation. Three frequency converter status indicator lights are also located in this area.

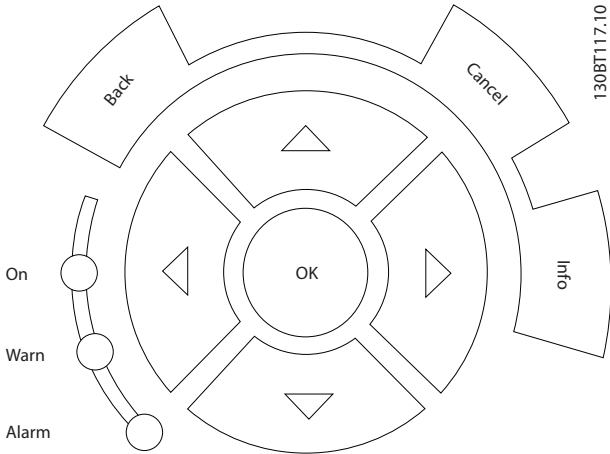

Illustration 5.5

Key	Function
Back	Reverts to the previous step or list in the menu structure.
Cancel	Cancels the last change or command as long as the display mode has not changed.
Info	Press for a definition of the function being displayed.
Navigation Keys	Use the four navigation keys to move between items in the menu.
OK	Use to access parameter groups or to enable a choice.

Table 5.3

Light	Indicator	Function
Green	ON	The ON light activates when the frequency converter receives power from mains voltage, a DC bus terminal, or an external 24 V supply.
Yellow	WARN	When warning conditions are met, the yellow WARN light comes on and text appears in the display area identifying the problem.
Red	ALARM	A fault condition causes the red alarm light to flash and an alarm text is displayed.

Table 5.4

5.1.5 Operation Keys

Operation keys are found at the bottom of the LCP.

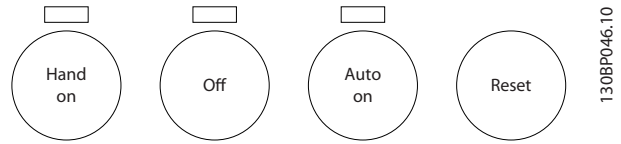

Illustration 5.6

Key	Function
Hand On	Starts the frequency converter in local control. <ul style="list-style-type: none"> Use the navigation keys to control frequency converter speed An external stop signal by control input or serial communication overrides the local hand on
Off	Stops the motor but does not remove power to the frequency converter.
Auto On	Puts the system in remote operational mode. <ul style="list-style-type: none"> Responds to an external start command by control terminals or serial communication Speed reference is from an external source
Reset	Resets the frequency converter manually after a fault has been cleared.

Table 5.5

5.2 Back Up and Copying Parameter Settings

Programming data is stored internally in the frequency converter.

- The data can be uploaded into the LCP memory as a storage back up
- Once stored in the LCP, the data can be downloaded back into the frequency converter
- Data can also be downloaded into other frequency converters by connecting the LCP into those units and downloading the stored settings. (This is a quick way to program multiple units with the same settings.)
- Initialisation of the frequency converter to restore factory default settings does not change data stored in the LCP memory

⚠ WARNING**UNINTENDED START!**

When the frequency converter is connected to AC mains, the motor may start at any time. The frequency converter, motor, and any driven equipment must be in operational readiness. Failure to be in operational readiness when the frequency converter is connected to AC mains could result in death, serious injury, or equipment or property damage.

5.2.1 Uploading Data to the LCP

1. Press [Off] to stop the motor before uploading or downloading data.
2. Go to *0-50 LCP Copy*.
3. Press [OK].
4. Select *All to LCP*.
5. Press [OK]. A progress bar shows the uploading process.
6. Press [Hand On] or [Auto On] to return to normal operation.

5.2.2 Downloading Data from the LCP

1. Press [Off] to stop the motor before uploading or downloading data.
2. Go to *0-50 LCP Copy*.
3. Press [OK].
4. Select *All from LCP*.
5. Press [OK]. A progress bar shows the downloading process.
6. Press [Hand On] or [Auto On] to return to normal operation.

5.3 Restoring Default Settings

CAUTION

Initialisation restores the unit to factory default settings. Any programming, motor data, localization, and monitoring records will be lost. Uploading data to the LCP provides a backup before initialisation.

Restoring the frequency converter parameter settings back to default values is done by initialisation of the frequency converter. Initialisation can be through *14-22 Operation Mode* or manually.

- Initialisation using *14-22 Operation Mode* does not change frequency converter data such as operating hours, serial communication selections,

personal menu settings, fault log, alarm log, and other monitoring functions

- Using *14-22 Operation Mode* is generally recommended
- Manual initialisation erases all motor, programming, localization, and monitoring data and restores factory default settings

5.3.1 Recommended Initialisation

1. Press [Main Menu] twice to access parameters.
2. Scroll to *14-22 Operation Mode*.
3. Press [OK].
4. Scroll to *Initialisation*.
5. Press [OK].
6. Remove power to the unit and wait for the display to turn off.
7. Apply power to the unit.

Default parameter settings are restored during start up. This may take slightly longer than normal.

8. Alarm 80 is displayed.
9. Press [Reset] to return to operation mode.

5.3.2 Manual Initialisation

1. Remove power to the unit and wait for the display to turn off.
2. Press and hold [Status], [Main Menu], and [OK] at the same time and apply power to the unit.

Factory default parameter settings are restored during start up. This may take slightly longer than normal.

Manual initialisation does not the following frequency converter information

- *15-00 Operating hours*
- *15-03 Power Up's*
- *15-04 Over Temp's*
- *15-05 Over Volt's*

6 Programming

6.1 Introduction

The frequency converter is programmed for its application functions using parameters. Parameters are accessed by pressing either [Quick Menu] or [Main Menu] on the LCP. (See for details on using the LCP function keys.) Parameters may also be accessed through a PC using the MCT 10 Set-up Software, go to www.VLT-software.com.

The quick menu is intended for initial start up (Q2-** *Quick Set Up*) and detailed instructions for common frequency converter applications (Q3-** *Function Set Up*). Step-by-step instructions are provided. These instructions enable the user to walk through the parameters used for programming applications in their proper sequence. Data entered in a parameter can change the options available in the parameters following that entry. The quick menu presents easy guidelines for getting most systems up and running.

The main menu accesses all parameters and allows for advanced frequency converter applications.

6.2 Programming Example

Here is an example for programming the frequency converter for a common application in open loop using the quick menu.

- This procedure programs the frequency converter to receive a 0-10 V DC analog control signal on input terminal 53
- The frequency converter will respond by providing 6-60 Hz output to the motor proportional to the input signal (0-10 V DC = 6-60 Hz)

Select the following parameters using the navigation keys to scroll to the titles and press [OK] after each action.

1. 3-15 Reference 1 Source

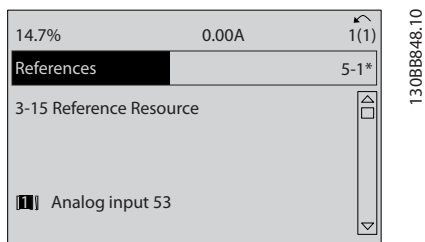

Illustration 6.1

2. 3-02 Minimum Reference. Set minimum internal frequency converter reference to 0 Hz. (This sets the minimum frequency converter speed at 0 Hz.)

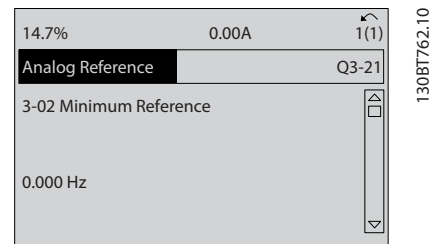

Illustration 6.2

3. 3-03 Maximum Reference. Set maximum internal frequency converter reference to 60 Hz. (This sets the maximum frequency converter speed at 60 Hz. Note that 50/60 Hz is a regional variation.)

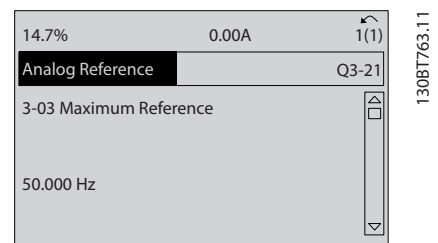

Illustration 6.3

4. 6-10 Terminal 53 Low Voltage. Set minimum external voltage reference on Terminal 53 at 0 V. (This sets the minimum input signal at 0 V.)

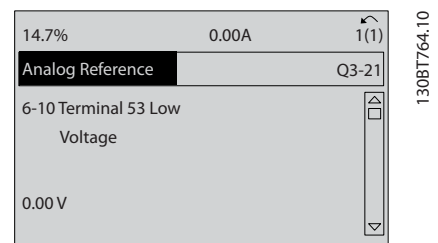

Illustration 6.4

5. 6-11 Terminal 53 High Voltage. Set maximum external voltage reference on Terminal 53 at 10 V. (This sets the maximum input signal at 10 V.)

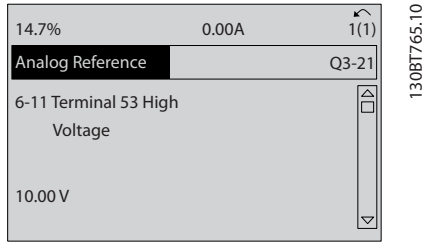

Illustration 6.5

6. 6-14 Terminal 53 Low Ref./Feedb. Value. Set minimum speed reference on Terminal 53 at 6 Hz. (This tells the frequency converter that the minimum voltage received on Terminal 53 (0 V) equals 6 Hz output.)

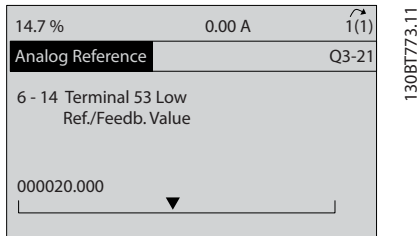

Illustration 6.6

7. 6-15 Terminal 53 High Ref./Feedb. Value. Set maximum speed reference on Terminal 53 at 60 Hz. (This tells the frequency converter that the maximum voltage received on Terminal 53 (10 V) equals 60 Hz output.)

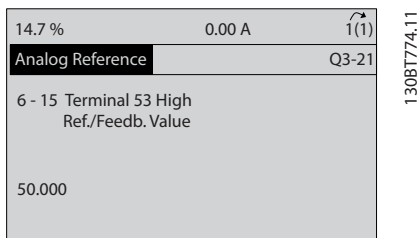

Illustration 6.7

With an external device providing a 0-10 V control signal connected to frequency converter terminal 53, the system is now ready for operation. Note that the scroll bar on the right in the last illustration of the display is at the bottom, indicating the procedure is complete.

Illustration 6.8 shows the wiring connections used to enable this set up.

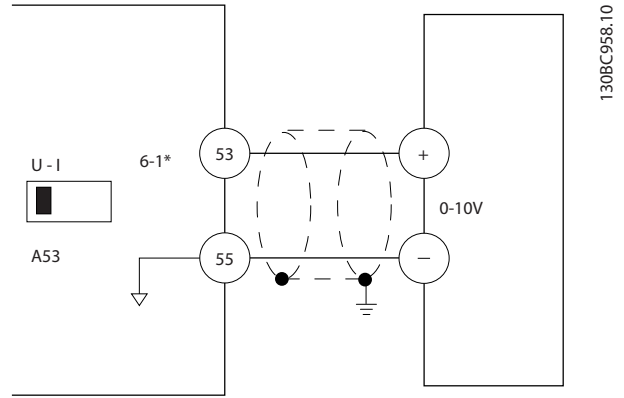

Illustration 6.8 Wiring Example for External Device Providing 0-10 V Control Signal (Frequency Converter Left, External Device Right)

6

6.3 Control Terminal Programming Examples

Control terminals can be programmed.

- Each terminal has specified functions it is capable of performing
- Parameters associated with the terminal enable the function

See for control terminal parameter number and default setting. (Default setting can change based on the selection in 0-03 Regional Settings.)

The following example shows accessing Terminal 18 to see the default setting.

1. Press [Main Menu] twice, scroll to parameter group 5-** Digital In/Out Parameter Data Set and press [OK].

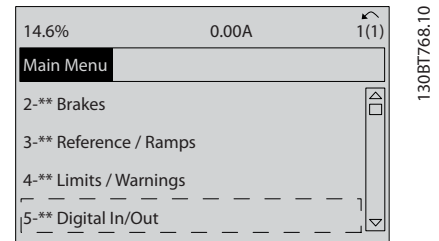

Illustration 6.9

2. Scroll to parameter group 5-1* *Digital Inputs* and press [OK].

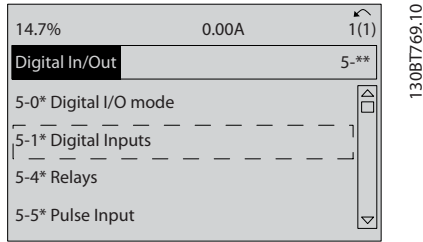

Illustration 6.10

3. Scroll to 5-10 *Terminal 18 Digital Input*. Press [OK] to access function choices. The default setting *Start* is shown.

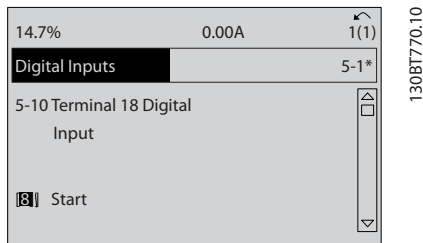

Illustration 6.11

6

6.4 International/North American Default Parameter Settings

Setting 0-03 *Regional Settings* to [0] *International* or [1] *North America* changes the default settings for some parameters. Table 6.1 lists those parameters that are effected.

Parameter	International default parameter value	North American default parameter value
0-03 Regional Settings	International	North America
1-20 Motor Power [kW]	See Note 1	See Note 1
1-21 Motor Power [HP]	See Note 2	See Note 2
1-22 Motor Voltage	230 V/400 V/575 V	208 V/460 V/575 V
1-23 Motor Frequency	50 Hz	60 Hz
3-03 Maximum Reference	50 Hz	60 Hz
3-04 Reference Function	Sum	External/Preset
4-13 Motor Speed High Limit [RPM]	1500 PM	1800 RPM

Parameter	International default parameter value	North American default parameter value
4-14 Motor Speed High Limit [Hz]	50 Hz	60 Hz
See Note 4		
4-19 Max Output Frequency	132 Hz	120 Hz
4-53 Warning Speed High	1500 RPM	1800 RPM
5-12 Terminal 27 Digital Input	Coast inverse	External interlock
5-40 Function Relay	No operation	No alarm
6-15 Terminal 53 High Ref./Feedb. Value	50	60
6-50 Terminal 42 Output	No operation	Speed 4-20 mA
14-20 Reset Mode	Manual reset	Infinite auto reset

Table 6.1 International/North American Default Parameter Settings

Note 1: 1-20 *Motor Power [kW]* is only visible when 0-03 *Regional Settings* is set to [0] *International*.

Note 2: 1-21 *Motor Power [HP]*, is only visible when 0-03 *Regional Settings* is set to [1] *North America*.

Note 3: This parameter is only visible when 0-02 *Motor Speed Unit* is set to [0] *RPM*.

Note 4: This parameter is only visible when 0-02 *Motor Speed Unit* is set to [1] *Hz*.

Note 5: The default value depends on the number of motor poles. For a 4 poled motor the international default value is 1500 RPM and for a 2 poled motor 3000 RPM. The corresponding values for North America is 1800 and 3600 RPM, respectively.

Changes made to default settings are stored and available for viewing in the quick menu along with any programming entered into parameters.

1. Press [Quick Menu].
2. Scroll to Q5 *Changes Made* and press [OK].
3. Select Q5-2 *Since Factory Setting* to view all programming changes or Q5-1 *Last 10 Changes* for the most recent.

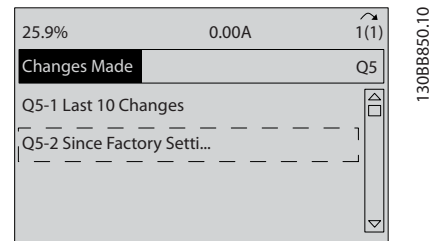

Illustration 6.12

6.4.1 Parameter Data Check

1. Press [Quick Menu].
2. Scroll to Q5 *Changes Made* and press [OK].

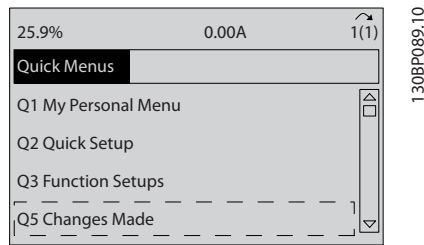

Illustration 6.13

3. Select Q5-2 *Since Factory Setting* to view all programming changes or Q5-1 *Last 10 Changes* for the most recent.

6.5 Parameter Menu Structure

Establishing the correct programming for applications often requires setting functions in several related parameters. These parameter settings provide the frequency converter with system details it needs to operate properly. System details may include such things as input and output signal types, programming terminals, minimum and maximum signal ranges, custom displays, automatic restart, and other features.

- See the LCP display to view detailed parameter programming and setting options
- Press [Info] in any menu location to view additional details for that function
- Press and hold [Main Menu] to enter a parameter number for direct access to that parameter
- Details for common application set ups are provided in *7 Application Set-Up Examples*

6.5.1 Quick Menu Structure



Q3-1 General Settings	0-24 Display Line 3 Large	1-00 Configuration Mode	Q3-31 Single Zone Ext. Set Point	20-70 Closed Loop Type
Q3-10 Adv. Motor Settings	0-37 Display Text 1	20-12 Reference/Feedback Unit	1-00 Configuration Mode	20-71 PID Performance
1-90 Motor Thermal Protection	0-38 Display Text 2	CL-13 Minimum Reference/Feedb.	20-12 Reference/Feedback Unit	20-72 PID Output Change
1-93 Thermistor Source	0-39 Display Text 3	CL-14 Maximum Reference/Feedb.	CL-13 Minimum Reference/Feedb.	20-73 Minimum Feedback Level
1-29 Automatic Motor Adaptation (AMA)	Q3-2 Open Loop Settings	6-22 Terminal 54 Low Current	CL-14 Maximum Reference/Feedb.	20-74 Maximum Feedback Level
14-01 Switching Frequency	Q3-20 Digital Reference	6-24 Terminal 54 Low Ref./Feedb. Value	6-10 Terminal 53 Low Voltage	20-79 PID Autotuning
4-53 Warning Speed High	3-02 Minimum Reference	6-25 Terminal 54 High Ref./Feedb. Value	6-11 Terminal 53 High Voltage	Q3-32 Multi Zone / Adv
Q3-11 Analog Output	3-03 Maximum Reference	6-26 Terminal 54 Filter Time Constant	6-12 Terminal 53 Low Current	1-00 Configuration Mode
6-50 Terminal 42 Output	3-10 Preset Reference	6-27 Terminal 54 Live Zero	6-13 Terminal 53 High Current	3-15 Reference 1 Source
6-51 Terminal 42 Output Min Scale	5-13 Terminal 29 Digital Input	6-00 Live Zero Timeout Time	6-14 Terminal 53 Low Ref./Feedb. Value	3-16 Reference 2 Source
6-52 Terminal 42 Output Max Scale	5-14 Terminal 32 Digital Input	6-01 Live Zero Timeout Function	6-15 Terminal 53 High Ref./Feedb. Value	20-00 Feedback 1 Source
Q3-12 Clock Settings	5-15 Terminal 33 Digital Input	20-21 Setpoint 1	6-22 Terminal 54 Low Current	20-01 Feedback 1 Conversion
0-70 Set Date and Time	Q3-21 Analog Reference	20-81 PID Normal/ Inverse Control	6-24 Terminal 54 Low Ref./Feedb. Value	20-02 Feedback 1 Source Unit
0-71 Date Format	3-02 Minimum Reference	20-82 PID Start Speed [RPM]	6-25 Terminal 54 High Ref./Feedb. Value	20-03 Feedback 2 Source
0-72 Time Format	3-03 Maximum Reference	20-83 PID Start Speed [Hz]	6-26 Terminal 54 Filter Time Constant	20-04 Feedback 2 Conversion
0-74 DST/Summertime	6-10 Terminal 53 Low Voltage	20-93 PID Proportional Gain	6-27 Terminal 54 Live Zero	20-05 Feedback 2 Source Unit
0-76 DST/Summertime Start	6-11 Terminal 53 High Voltage	20-94 PID Integral Time	6-00 Live Zero Timeout Time	20-06 Feedback 3 Source
0-77 DST/Summertime End	6-12 Terminal 53 Low Current	20-70 Closed Loop Type	6-01 Live Zero Timeout Function	20-07 Feedback 3 Conversion
Q3-13 Display Settings	6-13 Terminal 53 High Current	20-71 PID Performance	20-81 PID Normal/ Inverse Control	20-08 Feedback 3 Source Unit
0-20 Display Line 1.1 Small	6-14 Terminal 53 Low Ref./Feedb. Value	20-72 PID Output Change	20-82 PID Start Speed [RPM]	20-12 Reference/Feedback Unit
0-21 Display Line 1.2 Small	6-15 Terminal 53 High Ref./Feedb. Value	20-73 Minimum Feedback Level	20-83 PID Start Speed [Hz]	CL-13 Minimum Reference/Feedb.
0-22 Display Line 1.3 Small	Q3-3 Closed Loop Settings	20-74 Maximum Feedback Level	20-93 PID Proportional Gain	CL-14 Maximum Reference/Feedb.
0-23 Display Line 2 Large	Q3-30 Single Zone Int. Set Point	20-79 PID Autotuning	20-94 PID Integral Time	6-10 Terminal 53 Low Voltage

Table 6.2

6-11 Terminal 53 High Voltage	20-21 Setpoint 1	22-22 Low Speed Detection	22-21 Low Power Detection	22-87 Pressure at No-Flow Speed
6-12 Terminal 53 Low Current	20-22 Setpoint 2	22-23 No-Flow Function	22-22 Low Speed Detection	22-88 Pressure at Rated Speed
6-13 Terminal 53 High Current	20-81 PID Normal/ Inverse Control	22-24 No-Flow Delay	22-23 No-Flow Function	22-89 Flow at Design Point
6-14 Terminal 53 Low Ref./Feedb. Value	20-82 PID Start Speed [RPM]	22-40 Minimum Run Time	22-24 No-Flow Delay	22-90 Flow at Rated Speed
6-15 Terminal 53 High Ref./Feedb. Value	20-83 PID Start Speed [Hz]	22-41 Minimum Sleep Time	22-40 Minimum Run Time	1-03 Torque Characteristics
6-16 Terminal 53 Filter Time Constant	20-93 PID Proportional Gain	22-42 Wake-up Speed [RPM]	22-41 Minimum Sleep Time	1-73 Flying Start
6-17 Terminal 53 Live Zero	20-94 PID Integral Time	22-43 Wake-up Speed [Hz]	22-42 Wake-up Speed [RPM]	Q3-42 Compressor Functions
6-20 Terminal 54 Low Voltage	20-70 Closed Loop Type	22-44 Wake-up Ref./FB Difference	22-43 Wake-up Speed [Hz]	1-03 Torque Characteristics
6-21 Terminal 54 High Voltage	20-71 PID Performance	22-45 Setpoint Boost	22-44 Wake-up Ref./FB Difference	1-71 Start Delay
6-22 Terminal 54 Low Current	20-72 PID Output Change	22-46 Maximum Boost Time	22-45 Setpoint Boost	22-75 Short Cycle Protection
6-23 Terminal 54 High Current	20-73 Minimum Feedback Level	2-10 Brake Function	22-46 Maximum Boost Time	22-76 Interval between Starts
6-24 Terminal 54 Low Ref./Feedb. Value	20-74 Maximum Feedback Level	2-16 AC brake Max. Current	22-26 Dry Pump Function	22-77 Minimum Run Time
6-25 Terminal 54 High Ref./Feedb. Value	20-79 PID Autotuning	2-17 Over-voltage Control	22-27 Dry Pump Delay	5-01 Terminal 27 Mode
6-26 Terminal 54 Filter Time Constant	Q3-4 Application Settings	1-73 Flying Start	22-80 Flow Compensation	5-02 Terminal 29 Mode
6-27 Terminal 54 Live Zero	Q3-40 Fan Functions	1-71 Start Delay	22-81 Square-linear Curve Approximation	5-12 Terminal 27 Digital Input
6-00 Live Zero Timeout Time	22-60 Broken Belt Function	1-80 Function at Stop	22-82 Work Point Calculation	5-13 Terminal 29 Digital Input
6-01 Live Zero Timeout Function	22-61 Broken Belt Torque	2-00 DC Hold/Preheat Current	22-83 Speed at No-Flow [RPM]	5-40 Function Relay
4-56 Warning Feedback Low	22-62 Broken Belt Delay	4-10 Motor Speed Direction	22-84 Speed at No-Flow [Hz]	1-73 Flying Start
4-57 Warning Feedback High	4-64 Semi-Auto Bypass Set-up	Q3-41 Pump Functions	22-85 Speed at Design Point [RPM]	1-86 Compressor Min. Speed for Trip [RPM]
20-20 Feedback Function	1-03 Torque Characteristics	22-20 Low Power Auto Set-up	22-86 Speed at Design Point [Hz]	1-87 Compressor Min. Speed for Trip [Hz]

Table 6.3



6.5.2 Main Menu Structure

0-0*	Operation / Display	1-00	Load and Motor	1-90	Motor Thermal Protection	4-17	Torque Limit Generator Mode	5-65	Pulse Output Max Freq #29
0-01	Basic Settings	1-01	General Settings	1-91	Motor External Fan	4-18	Current Limit	5-66	Terminal X30/6 Pulse Output Variable
0-02	Motor Speed Unit	1-02	Configuration Mode	1-93	Thermistor Source	4-19	Max Output Frequency	5-68	Pulse Output Max Freq #X30/6
0-03	Regional Settings	1-03	Torque Characteristics	2-0*	Brakes	4-5*	Adj. Warnings	5-8*	I/O Options
0-04	Operating State at Power-up	1-04	Clockwise Direction	2-0*	DC Brake	4-50	Warning Current Low	5-80	AHF Cap Reconnect Delay
0-05	Local Mode Unit	1-1*	Motor Selection	2-00	DC Hold/Preheat Current	4-51	Warning Current High	5-9*	Bus Controlled
0-1*	Set-up Operations	1-10	Motor Construction	2-01	DC Brake Current	4-52	Warning Speed Low	5-90	Digital & Relay Bus Control
0-10	Active Set-up	1-11	WG+ PM	2-02	DC Braking Time	4-53	Warning Speed High	5-93	Pulse Out #27 Bus Control
0-11	Programming Set-up	1-14	Damping Gain	2-03	DC Brake Cut In Speed [RPM]	4-54	Warning Reference Low	5-94	Pulse Out #27 Timeout Preset
0-12	This Set-up Linked to	1-15	Low Speed Filter Time Const.	2-04	DC Brake Cut In Speed [Hz]	4-55	Warning Reference High	5-95	Pulse Out #29 Bus Control
0-13	Readout: Linked Set-ups	1-16	High Speed Filter Time Const.	2-06	Parking Current	4-56	Warning Feedback Low	5-96	Pulse Out #29 Timeout Preset
0-14	Readout: Prog. Set-ups / Channel	1-17	Voltage filter time const.	2-07	Parking Time	4-57	Warning Feedback High	5-97	Pulse Out #X30/6 Bus Control
0-2*	LCP Display	1-2*	Motor Data	2-1*	Brake Energy Funct.	4-58	Missing Motor Phase Function	5-98	Pulse Out #X30/6 Timeout Preset
0-20	Display Line 1.1 Small	1-20	Motor Power [kW]	2-10	Brake Function	4-6*	Speed Bypass	6-0*	Analog In/Out
0-21	Display Line 1.2 Small	1-21	Motor Power [HP]	2-11	Brake Resistor (ohm)	4-60	Bypass Speed From [RPM]	6-0*	Analog I/O Mode
0-22	Display Line 1.3 Small	1-22	Motor Voltage	2-12	Brake Power Limit (kW)	4-61	Bypass Speed From [Hz]	6-00	Live Zero Timeout Function
0-23	Display Line 2 Large	1-23	Motor Frequency	2-13	Brake Power Monitoring	4-62	Bypass Speed To [RPM]	6-01	Live Zero Timeout Function
0-24	Display Line 3 Large	1-24	Motor Current	2-15	Brake Check	4-63	Bypass Speed To [Hz]	6-02	Fire Mode Live Zero Timeout Function
0-25	My Personal Menu	1-25	Motor Nominal Speed	2-16	AC brake Max. Current	4-64	Semi-Auto Bypass Set-up	6-1*	Analog Input 53
0-30	Custom Readout	1-26	Motor Cont. Rated Torque	2-17	Over-voltage Control	5-*	Digital In/Out	6-10	Terminal 53 Low Voltage
0-31	Custom Readout Min Value	1-28	Motor Rotation Check	3-0*	Reference / Ramps	5-0*	Digital I/O mode	6-11	Terminal 53 High Voltage
0-32	Custom Readout Max Value	1-29	Automatic Motor Adaptation (AMA)	3-0*	Reference Limits	5-00	Digital I/O Mode	6-12	Terminal 53 Low Current
0-33	Display Text 1	1-3*	Adv. Motor Data	3-02	Minimum Reference	5-01	Terminal 27 Mode	6-13	Terminal 53 High Current
0-34	Display Text 2	1-30	Stator Resistance (Rs)	3-03	Maximum Reference	5-02	Terminal 29 Mode	6-14	Terminal 53 Low Ref./Feedb. Value
0-35	Display Text 3	1-31	Rotor Resistance (Rr)	3-04	Reference Function	5-1*	Digital Inputs	6-15	Terminal 53 High Ref./Feedb. Value
0-40	[Hand on] Key on LCP	1-35	Main Reactance (Xh)	3-10	Preset Reference	5-10	Terminal 18 Digital Input	6-16	Terminal 53 Filter Time Constant
0-41	[Off] Key on LCP	1-36	Iron Loss Resistance (Rfe)	3-11	Jog Speed [Hz]	5-11	Terminal 19 Digital Input	6-17	Terminal 53 Live Zero
0-42	[Auto on] Key on LCP	1-37	d-axis Inductance (Ld)	3-13	Reference Site	5-12	Terminal 27 Digital Input	6-2*	Analog Input 54
0-43	[Reset] Key on LCP	1-39	Motor Poles	3-15	Reference 1 Source	5-13	Terminal 29 Digital Input	6-20	Terminal 54 Low Voltage
0-44	[Drive Bypass] Key on LCP	1-40	Back EMF at 1000 RPM	3-16	Reference 2 Source	5-14	Terminal 32 Digital Input	6-21	Terminal 54 High Voltage
0-45	[Copy/Save] Key on LCP	1-50	Motor Magnetisation at Zero Speed	3-17	Reference 3 Source	5-15	Terminal 33 Digital Input	6-22	Terminal 54 Low Current
0-50	LCP Copy	1-51	Min Speed Normal Magnetising [RPM]	3-19	Jog Speed [RPM]	5-17	Terminal X30/2 Digital Input	6-23	Terminal 54 High Current
0-51	Set-up Copy	1-52	Min Speed Normal Magnetising [Hz]	3-41	Ramp 1 Ramp Up Time	5-18	Terminal X30/3 Digital Input	6-24	Terminal 54 Low Ref./Feedb. Value
0-6*	Password	1-58	Flystart Test Pulses Current	3-42	Ramp 1 Ramp Down Time	5-19	Terminal X30/4 Digital Input	6-25	Terminal 54 High Ref./Feedb. Value
0-60	Main Menu Password	1-60	Low Speed Load Compensation	3-44	Ramp 2 Ramp Up Time	5-3*	Terminal 37 Safe Stop	6-26	Terminal 54 Filter Time Constant
0-61	Access to Main Menu w/o Password	1-61	High Speed Load Compensation	3-45	Ramp 2 Ramp Down Time	5-30	Terminal 27 Digital Output	6-3*	Analog Input X30/11
0-65	Personal Menu Password	1-62	Slip Compensation	3-51	Ramp 2 Ramp Up Time	5-31	Terminal 29 Digital Output	6-30	Terminal X30/11 High Voltage
0-66	Access to Personal Menu w/o Password	1-63	Slip Compensation Time Constant	3-52	Ramp 2 Ramp Down Time	5-32	Term X30/6 Digi Out (MCB 101)	6-31	Terminal X30/11 Low Voltage
0-7*	Clock Settings	1-64	Resonance Dampening	3-8*	Other Ramps	5-33	Term X30/7 Digi Out (MCB 101)	6-34	Term. X30/11 Low Ref./Feedb. Value
0-70	Date and Time	1-65	Resonance Dampening Time Constant	3-80	Jog Ramp Time	5-4*	Relays	6-35	Term. X30/11 High Ref./Feedb. Value
0-71	Date Format	1-66	Min. Current at Low Speed	3-81	Quick Stop Ramp Up Time	5-41	On Delay, Relay	6-36	Term. X30/11 Filter Time Constant
0-72	Time Format	1-67	Compressor Start Max Speed [RPM]	3-82	Starting Ramp Up Time	5-42	Off Delay, Relay	6-37	Term. X30/11 Live Zero
0-73	DST/Summertime	1-7*	Compressor Start Max Speed [Hz]	3-9*	Digital Pot.Meter	5-5*	Pulse Input	6-4*	Analog Input X30/12
0-74	DST/Summertime End	1-70	Compressor Start Max Time to Trip	3-90	Step Size	5-50	Term. 29 Low Frequency	6-40	Terminal X30/12 Low Voltage
0-75	Working Days	1-71	Function at Stop	3-91	Ramp Time	5-51	Term. 29 High Frequency	6-41	Terminal X30/12 High Voltage
0-76	Additional Non-Working Days	1-72	Min Speed for Function at Stop [RPM]	3-92	Power Restore	5-52	Term. 29 Low Ref./Feedb. Value	6-44	Term. X30/12 Low Ref./Feedb. Value
0-77	Date and Time Readout	1-73	Min Speed for Function at Stop [Hz]	3-93	Maximum Limit	5-53	Term. 29 High Ref./Feedb. Value	6-45	Term. X30/12 High Ref./Feedb. Value
0-81	Additional Working Days	1-77	Trip Speed Low [RPM]	3-94	Minimum Limit	5-54	Pulse Filter Time Constant #29	6-46	Term. X30/12 Filter Time Constant
0-82	Additional Non-Working Days	1-78	Trip Speed Low [Hz]	3-95	Ramp Delay	5-55	Term. 33 Low Frequency	6-47	Term. X30/12 Live Zero
0-83	Date and Time Readout	1-79	Motor Temperature	4-*	Limits / Warnings	5-56	Term. 33 High Frequency	6-5*	Analog Output 42
0-88		1-80	Stop Adjustments	4-1*	Motor Limits	5-57	Term. 33 Low Ref./Feedb. Value	6-50	Terminal 42 Output
		1-81	Function at Stop	4-10	Motor Speed Direction	5-58	Term. 33 High Ref./Feedb. Value	6-51	Terminal 42 Output Min Scale
		1-82	Min Speed for Function at Stop [RPM]	4-11	Motor Speed Low Limit [RPM]	5-59	Term. 33 High Ref./Feedb. Value	6-52	Terminal 42 Output Max Scale
		1-83	Min Speed for Function at Stop [Hz]	4-12	Motor Speed Low Limit [Hz]	5-6*	Pulse Filter Time Constant #33	6-53	Terminal 42 Output Bus Control
		1-84	Trip Speed Low [RPM]	4-13	Motor Speed High Limit [RPM]	5-60	Pulse Output	6-54	Terminal 42 Output Timeout Preset
		1-85	Trip Speed Low [Hz]	4-14	Motor Speed High Limit [Hz]	5-62	Terminal 27 Pulse Output Variable	6-55	Analog Output Filter
		1-9*	Motor Temperature	4-16	Torque Limit Motor Mode	5-63	Pulse Output Max Freq #27	6-6*	Analog Output X30/8
							Terminal 29 Pulse Output Variable	6-60	Terminal X30/8 Output

6-61	Terminal X30/8 Min. Scale	11-18	LonWorks Revision	14-6*	Auto Derate	15-76	Option in Slot C1	16-68	Pulse Input #33 [Hz]
6-62	Terminal X30/8 Max. Scale	11-2*	LON Param. Access	14-60	Function at Over Temperature	15-77	Slot C1 Option SW Version	16-69	Pulse Output #27 [Hz]
6-63	Terminal X30/8 Output Bus Control	11-21	Store Data Values	14-61	Function at Inverter Overload	15-9*	Parameter Info	16-70	Pulse Output #29 [Hz]
6-64	Terminal X30/8 Output Timeout Preset	13-3*	Smart Logic	14-62	Inv. Overload Derate Current	15-92	Defined Parameters	16-71	Relay Output [bin]
8-0*	General Settings	13-0*	SLC Settings	15-5*	Drive Information	15-93	Modified Parameters	16-72	Counter A
8-01	Control Site	13-00	SL Controller Mode	15-0*	Operating Data	15-98	Drive Identification	16-73	Counter B
8-02	Control Source	13-01	Start Event	15-00	Operating Hours	15-99	Parameter Metadata	16-75	Analog In X30/11
8-03	Control Timeout Time	13-02	Stop Event	15-01	Running Hours	16-1*	Data Readouts	16-76	Analog In X30/12
8-04	Control Timeout Function	13-03	Reset SLC	15-02	kWh Counter	16-0*	General Status	16-77	Analog Out X30/8 [mA]
8-05	End-of-Timeout Function	13-1*	Comparators	15-03	Power Up's	16-00	Control Word	16-8*	Fieldbus & FC Port
8-06	Reset Control Timeout	13-10	Comparator Operand	15-04	Over Temp's	16-01	Reference [Unit]	16-80	Fieldbus CTW 1
8-07	Diagnosis Trigger	13-11	Comparator Operator	15-05	Over Volt's	16-02	Reference [%]	16-82	Fieldbus REF 1
8-08	Readout Filtering	13-12	Comparator Value	15-06	Reset kWh Counter	16-03	Status Word	16-84	Comm. Option STW
8-09	Communication Charset	13-2*	Timers	15-07	Reset Running Hours Counter	16-05	Main Actual Value [%]	16-85	FC Port CTW 1
8-1*	Control Settings	13-20	SL Controller Timer	15-08	Number of Starts	16-09	Custom Readout	16-86	FC Port REF 1
8-10	Control Profile	13-4*	Logic Rules	15-1*	Data Log Settings	16-1*	Motor Status	16-9*	Diagnosis Readouts
8-13	Configurable Status Word STW	13-40	Logic Rule Boolean 1	16-10	Power [kW]	16-90	Alarm Word	16-90	Alarm Word
8-3*	FC Port Settings	13-41	Logic Rule Operator 1	16-11	Power [hp]	16-91	Alarm Word 2	16-91	Alarm Word 2
8-30	Protocol	13-42	Logic Rule Boolean 2	16-12	Trigger Event	16-12	Motor Voltage	16-92	Warning Word
8-31	Address	13-43	Logic Rule Operator 2	16-13	Logging Mode	16-13	Frequency	16-93	Warning Word 2
8-32	Baud Rate	13-44	Logic Rule Boolean 3	16-14	Samples Before Trigger	16-14	Motor Current	16-94	Ext. Status Word
8-33	Parity / Stop Bits	13-5*	States	16-15	Historic Log	16-15	Frequency [%]	16-95	Ext. Status Word 2
8-34	Estimated cycle time	13-51	SL Controller Event	16-16	Historic Log: Event	16-16	Torque [Nm]	16-96	Maintenance Word
8-35	Minimum Response Delay	13-52	SL Controller Action	16-17	Historic Log: Value	16-17	Speed [RPM]	18-3*	Info & Readouts
8-36	Maximum Response Delay	14-0*	Special Functions	16-18	Historic Log: Time	16-18	Motor Thermal	18-0*	Maintenance Log
8-37	Maximum Inter-Char Delay	14-00	Switching Pattern	16-22	Historic Log: Date and Time	16-22	Torque [%]	18-01	Maintenance Log: Item
8-4*	FC MC protocol set	14-01	Switching Frequency	16-26	Alarm Log	16-26	Power Filtered [kW]	18-02	Maintenance Log: Action
8-40	Telegram Selection	14-01	Overmodulation	16-27	Alarm Log: Error Code	16-27	Power Filtered [hp]	18-03	Maintenance Log: Time
8-42	PCD write configuration	14-03	PWM Random	16-30	Alarm Log: Value	16-30	DC Link Voltage	18-1*	Fire Mode Log
8-43	PCD read configuration	14-04	Mains On/Off	16-32	Alarm Log: Time	16-32	Brake Energy /s	18-10	Fire Mode Log: Event
8-50	Coasting Select	14-10	Mains Failure	16-33	Alarm Log: Date and Time	16-33	Brake Energy /2 min	18-12	Fire Mode Log: Time
8-52	DC Brake Select	14-11	Mains Voltage at Mains Fault	16-34	Drive Identification	16-34	Heatsink Temp.	18-3*	Inputs & Outputs
8-53	Reversing Select	14-12	Function at Mains Imbalance	16-35	FC Type	16-35	Inverter Thermal	18-30	Analog Input X42/1
8-54	Start Select	14-2*	Reset Functions	16-36	Voltage	16-36	Inv. Nom. Current	18-31	Analog Input X42/3
8-55	Set-up Select	14-20	Reset Mode	16-37	Software Version	16-37	Inv. Max. Current	18-32	Analog Input X42/5
8-56	Preset Reference Select	14-21	Automatic Restart Time	16-38	Ordered Typecode String	16-38	SL Controller State	18-33	Analog Out X42/7 [V]
8-8*	FC Port Diagnostics	14-22	Operation Mode	16-39	Actual Typecode String	16-39	Control Card Temp.	18-34	Analog Out X42/9 [V]
8-80	Bus Message Count	14-23	Typecode Setting	16-40	Frequency Converter Ordering No	16-40	Logging Buffer Full	18-35	Analog Out X42/11 [V]
8-81	Bus Error Count	14-25	Trip Delay at Torque Limit	16-41	Power Card Ordering No	16-41	Logging Buffer Full	18-36	Analog Input X48/2 [mA]
8-82	Slave Messages Rcvd	14-26	Trip Delay at Inverter Fault	16-43	LCP Id No	16-43	Timed Actions Status	18-37	Temp. Input X48/4
8-83	Slave Error Count	14-28	Production Settings	16-49	SW ID Control Card	16-49	Current Fault Source	18-38	Temp. Input X48/7
8-84	Slave Messages Sent	14-29	Service Code	16-50	SW ID Power Card	16-50	Ref. & Feeds.	18-39	Temp. Input X48/10
8-85	Slave Timeout Errors	14-30	Current Limit Ctrl.	16-52	Frequency Converter Serial Number	16-52	External Reference	18-5*	Ref. & Feeds.
8-89	Diagnosics Count	14-31	Current Lim Ctrl, Proportional Gain	16-53	Power Card Serial Number	16-53	Feedback [Unit]	18-50	Sensorless Readout [unit]
8-9*	Bus Jog / Feedback	14-32	Current Lim Ctrl, Integration Time	16-54	Vendor URL	16-54	Digi Pot Reference	20-0*	Drive Closed Loop
8-90	Bus Jog 1 Speed	14-40	Current Lim Ctrl, Filter Time	16-55	Vendor Name	16-55	Feedback 1 [Unit]	20-0*	Feedback
8-91	Bus Jog 2 Speed	14-40	VT Level	16-56	CSW Filename	16-56	Feedback 2 [Unit]	20-01	Feedback 1 Source
8-94	Bus Feedback 1	14-41	AEO Minimum Magnetisation	16-60	Option Mounted	16-58	PID Output [%]	20-02	Feedback 1 Conversion
8-95	Bus Feedback 2	14-42	Minimum AEO Frequency	16-61	Option SW Version	16-59	Optimal Input	20-03	Feedback 2 Source Unit
8-96	Bus Feedback 3	14-43	Motor Cosphi	16-62	Option Ordering No	16-60	Digital Input	20-04	Feedback 2 Conversion
11-1*	LonWorks	14-45*	Environment	16-63	Option Serial No	16-61	Terminal 53 Switch Setting	20-05	Feedback 2 Source Unit
11-0*	LonWorks ID	14-50	RFI Filter	16-64	Option in Slot A	16-62	Analog Input 53	20-06	Feedback 3 Source
11-00	Neuron ID	14-51	DC Link Compensation	16-65	Slot A Option SW Version	16-63	Terminal 54 Switch Setting	20-07	Feedback 3 Conversion
11-1*	LON Functions	14-52	Fan Control	16-66	Option in Slot B	16-64	Analog Input 54	20-08	Feedback 3 Source Unit
11-10	Drive Profile	14-53	Fan Monitor	16-67	Slot B Option SW Version	16-65	Analog Output 42 [mA]	20-12	Reference/Feedback Unit
11-15	LON Warning Word	14-55	Output Filter	16-75	Option in Slot C0	16-66	Digital Output [bin]	20-13	Minimum Reference/Feedb.
11-17	XIF Revision	14-59	Actual Number of Inverter Units						

20-14	Maximum Reference/Feedb.	21-23	Ext. 1 Differentiation Time	22-41	Minimum Sleep Time	23-63	Timed Period Start	25-91	Manual Alternation
20-2*	Feedback/Setpoint	21-24	Ext. 1 Dif. Gain Limit	22-42	Wake-up Speed [RPM]	23-64	Timed Period Stop	26-5*	Analog I/O Option
20-20	Feedback Function	21-3*	Ext. CL 2 Ref./Fb.	22-43	Wake-up Speed [Hz]	23-65	Minimum Bin Value	26-0*	Analog I/O Mode
20-21	Setpoint 1	21-30	Ext. 2 Ref./Feedback Unit	22-44	Wake-up Ref./FB Difference	23-66	Reset Continuous Bin Data	26-00	Terminal X42/1 Mode
20-22	Setpoint 2	21-31	Ext. 2 Minimum Reference	22-45	Setpoint Boost	23-67	Reset Timed Bin Data	26-01	Terminal X42/3 Mode
20-23	Setpoint 3	21-32	Ext. 2 Maximum Reference	22-46	Maximum Boost Time	23-8*	Payback Counter	26-02	Terminal X42/5 Mode
20-3*	Feedb. Adv. Conv.	21-33	Ext. 2 Reference Source	22-5*	End of Curve	23-80	Power Reference Factor	26-1*	Analog Input X42/1
20-30	Refrigerant	21-34	Ext. 2 Feedback Source	22-50	End of Curve Function	23-81	Energy Cost	26-10	Terminal X42/1 Low Voltage
20-31	User Defined Refrigerant A1	21-35	Ext. 2 Setpoint	22-51	End of Curve Delay	23-82	Investment	26-11	Terminal X42/1 High Voltage
20-32	User Defined Refrigerant A2	21-37	Ext. 2 Reference [Unit]	22-6*	Broken Belt Detection	23-83	Energy Savings	26-14	Term. X42/1 Low Ref./Feedb. Value
20-33	User Defined Refrigerant A3	21-38	Ext. 2 Feedback [Unit]	22-60	Broken Belt Function	23-84	Cost Savings	26-15	Term. X42/1 High Ref./Feedb. Value
20-34	Duct 1 Area [m2]	21-39	Ext. 2 Output [%]	22-61	Broken Belt Torque	25-5*	Pack Controller	26-16	Term. X42/1 Filter Time Constant
20-35	Duct 1 Area [in2]	21-4*	Ext. CL 2 PID	22-62	Broken Belt Delay	25-0*	System Settings	26-17	Term. X42/1 Live Zero
20-36	Duct 2 Area [m2]	21-40	Ext. 2 Normal/Inverse Control	22-7*	Short Cycle Protection	25-00	Cascade Controller	26-2*	Analog Input X42/3
20-37	Duct 2 Area [in2]	21-41	Ext. 2 Proportional Gain	22-75	Short Cycle Protection	25-02	Motor Start	26-20	Terminal X42/3 Low Voltage
20-38	Air Density Factor [%]	21-42	Ext. 2 Integral Time	22-76	Interval between Starts	25-04	Pump Cycling	26-21	Terminal X42/3 High Voltage
20-6*	Sensorless	21-43	Ext. 2 Differentiation Time	22-77	Minimum Run Time	25-05	Fixed Lead Pump	26-24	Term. X42/3 Low Ref./Feedb. Value
20-60	Sensorless Unit	21-44	Ext. 2 Dif. Gain Limit	22-78	Minimum Run Time Override	25-06	Number of Pumps	26-25	Term. X42/3 High Ref./Feedb. Value
20-69	Sensorless Information	21-5*	Ext. CL 3 Ref./Fb.	22-79	Minimum Run Time Override Value	25-2*	Bandwidth Settings	26-26	Term. X42/3 Filter Time Constant
20-7*	PID Autotuning	21-50	Ext. 3 Ref./Feedback Unit	22-8*	Flow Compensation	25-20	Staging Bandwidth	26-27	Term. X42/3 Live Zero
20-70	Closed Loop Type	21-51	Ext. 3 Minimum Reference	22-80	Flow Compensation	25-21	Override Bandwidth	26-3*	Analog Input X42/5
20-71	PID Performance	21-52	Ext. 3 Maximum Reference	22-81	Square-linear Curve Approximation	25-22	Fixed Speed Bandwidth	26-30	Terminal X42/5 Low Voltage
20-72	PID Output Change	21-53	Ext. 3 Reference Source	22-82	Work Point Calculation	25-23	SBW Staging Delay	26-31	Terminal X42/5 High Voltage
20-73	Minimum Feedback Level	21-54	Ext. 3 Feedback Source	22-83	Speed at No-Flow [RPM]	25-24	SBW Destaging Delay	26-34	Term. X42/5 Low Ref./Feedb. Value
20-74	Maximum Feedback Level	21-55	Ext. 3 Setpoint	22-84	Speed at No-Flow [Hz]	25-25	OBW Time	26-35	Term. X42/5 High Ref./Feedb. Value
20-79	PID Autotuning	21-57	Ext. 3 Reference [Unit]	22-85	Speed at Design Point [RPM]	25-26	Destage At No-Flow	26-36	Term. X42/5 Filter Time Constant
20-8*	PID Basic Settings	21-58	Ext. 3 Feedback [Unit]	22-86	Speed at Design Point [Hz]	25-27	Stage Function	26-37	Term. X42/5 Live Zero
20-81	PID Normal/ Inverse Control	21-59	Ext. 3 Output [%]	22-87	Pressure at No-Flow Speed	25-28	Stage Function Time	26-4*	Analog Out X42/7
20-82	PID Start Speed [RPM]	21-6*	Ext. CL 3 PID	22-88	Pressure at Rated Speed	25-29	Destage Function	26-40	Terminal X42/7 Output
20-83	PID Start Speed [Hz]	21-60	Ext. 3 Normal/Inverse Control	22-89	Pressure at Design Point	25-30	Destage Function Time	26-41	Terminal X42/7 Min. Scale
20-84	On Reference Bandwidth	21-61	Ext. 3 Proportional Gain	22-90	Flow at Design Point	25-30	Destage Function Time	26-42	Terminal X42/7 Max. Scale
20-9*	PID Controller	21-62	Ext. 3 Integral Time	22-9*	Flow at Rated Speed	25-4*	Staging Settings	26-43	Terminal X42/7 Timeout Preset
20-91	PID Anti Windup	21-63	Ext. 3 Differentiation Time	23-0*	Time-based Functions	25-40	Ramp Down Delay	26-44	Terminal X42/7 Time Control
20-93	PID Proportional Gain	21-64	Ext. 3 Dif. Gain Limit	23-0*	Timed Actions	25-41	Ramp Up Delay	26-45	Terminal X42/7 Timeout Preset
20-94	PID Integral Time	22-*	Appl. Functions	23-00	ON Time	25-42	Staging Threshold	26-5*	Analog Out X42/9
20-95	PID Differentiation Time	22-0*	Miscellaneous	23-01	ON Action	25-43	Staging Threshold	26-50	Terminal X42/9 Output
20-96	PID Diff. Gain Limit	22-00	External Interlock Delay	23-02	OFF Time	25-44	Staging Speed [RPM]	26-51	Terminal X42/9 Min. Scale
21-*	Ext. Closed Loop	22-01	Power Filter Time	23-03	OFF Action	25-45	Staging Speed [Hz]	26-52	Terminal X42/9 Max. Scale
21-0*	Ext. CL Autotuning	22-02	No-Flow Detection	23-04	Occurrence	25-46	Destaging Speed [RPM]	26-53	Terminal X42/9 Bus Control
21-00	Closed Loop Type	22-2*	Low Power Auto Set-up	23-0*	Timed Actions Settings	25-47	Destaging Speed [Hz]	26-54	Terminal X42/9 Timeout Preset
21-01	PID Performance	22-20	Low Power Detection	23-08	Timed Actions Mode	25-5*	Alternation Settings	26-6*	Analog Out X42/11
21-02	PID Output Change	22-21	Low Speed Detection	23-09	Timed Actions Reactivation	25-50	Lead Pump Alternation	26-60	Terminal X42/11 Output
21-03	Minimum Feedback Level	22-22	No-Flow Function	23-1*	Maintenance	25-51	Alternation Event	26-61	Terminal X42/11 Min. Scale
21-04	Maximum Feedback Level	22-23	No-Flow Delay	23-10	Maintenance Item	25-52	Alternation Time Interval	26-62	Terminal X42/11 Max. Scale
21-09	PID Autotuning	22-24	Dry Pump Function	23-11	Maintenance Action	25-53	Alternation Timer Value	26-63	Terminal X42/11 Bus Control
21-1*	Ext. CL 1 Ref./Fb.	22-26	Dry Pump Delay	23-12	Maintenance Time Base	25-54	Alternation Predefined Time	26-64	Terminal X42/11 Timeout Preset
21-10	Ext. 1 Ref./Feedback Unit	22-27	No-Flow Power Tuning	23-14	Maintenance Date and Time	25-55	Alternate if Load < 50%	28-*	Compressor Functions
21-11	Ext. 1 Minimum Reference	22-30	No-Flow Power	23-1*	Maintenance Reset	25-56	Staging Mode at Alternation	28-2*	Discharge Temperature
21-12	Ext. 1 Maximum Reference	22-31	Power Correction Factor	23-15	Reset Maintenance Word	25-58	Run Next Pump Delay	28-20	Temperature Source
21-13	Ext. 1 Reference Source	22-32	Low Speed [RPM]	23-16	Maintenance Text	25-59	Run on Mains Delay	28-21	Temperature Unit
21-14	Ext. 1 Feedback Source	22-33	Low Speed [Hz]	23-5*	Energy Log	25-8*	Status	28-24	Warning Level
21-15	Ext. 1 Setpoint	22-34	Low Speed Power [kW]	23-50	Energy Log Resolution	25-80	Cascade Status	28-25	Warning Action
21-17	Ext. 1 Reference [Unit]	22-35	Low Speed Power [HP]	23-51	Period Start	25-81	Pump Status	28-26	Emergency Level
21-18	Ext. 1 Feedback [Unit]	22-36	High Speed [RPM]	23-52	Energy Log	25-82	Lead Pump	28-27	Discharge Temperature
21-19	Ext. 1 Output [%]	22-37	High Speed [Hz]	23-54	Reset Energy Log	25-83	Relay Status	28-7*	Day/Night Settings
21-2*	Ext. CL 1 PID	22-38	High Speed Power [kW]	23-6*	Trending	25-84	Pump ON Time	28-71	Day/Night Bus Indicator
21-20	Ext. 1 Normal/Inverse Control	22-39	High Speed Power [HP]	23-60	Trend Variable	25-85	Relay ON Time	28-72	Enable Day/Night Via Bus
21-21	Ext. 1 Proportional Gain	22-4*	Sleep Mode	23-61	Continuous Bin Data	25-86	Reset Relay Counters	28-73	Night Setback
21-22	Ext. 1 Integral Time	22-40	Minimum Run Time	23-62	Timed Bin Data	25-9*	Service	28-75	Night Speed Drop Override
						25-90	Pump Interlock	28-76	Night Speed Drop [Hz]

28-8* PO Optimization

28-81 dPO Offset
28-82 PO
28-83 PO Setpoint
28-84 PO Reference
28-85 PO Minimum Reference
28-86 PO Maximum Reference
28-87 Most Loaded Controller

28-9* Injection Control

28-90 Injection On
28-91 Delayed Compressor Start

7 Application Set-Up Examples

7.1 Introduction

NOTE

A jumper wire may be required between terminal 12 (or 13) and terminal 37 for the frequency converter to operate when using factory default programming values.

The examples in this section are intended as a quick reference for common applications.

- Parameter settings are the regional default values unless otherwise indicated (selected in *0-03 Regional Settings*)
- Parameters associated with the terminals and their settings are shown next to the drawings

- Where switch settings for analog terminals A53 or A54 are required, these are also shown

7.2 Set-up Examples

7.2.1 Compressor

The wizard guides the user through the set up of a refrigeration compressor by asking him to input data about the compressor and the refrigeration system on which the frequency converter will be running. All terminology and units used within the wizard are common refrigeration type and set up is thus completed in 10-15 easy steps using just two keys of the LCP.

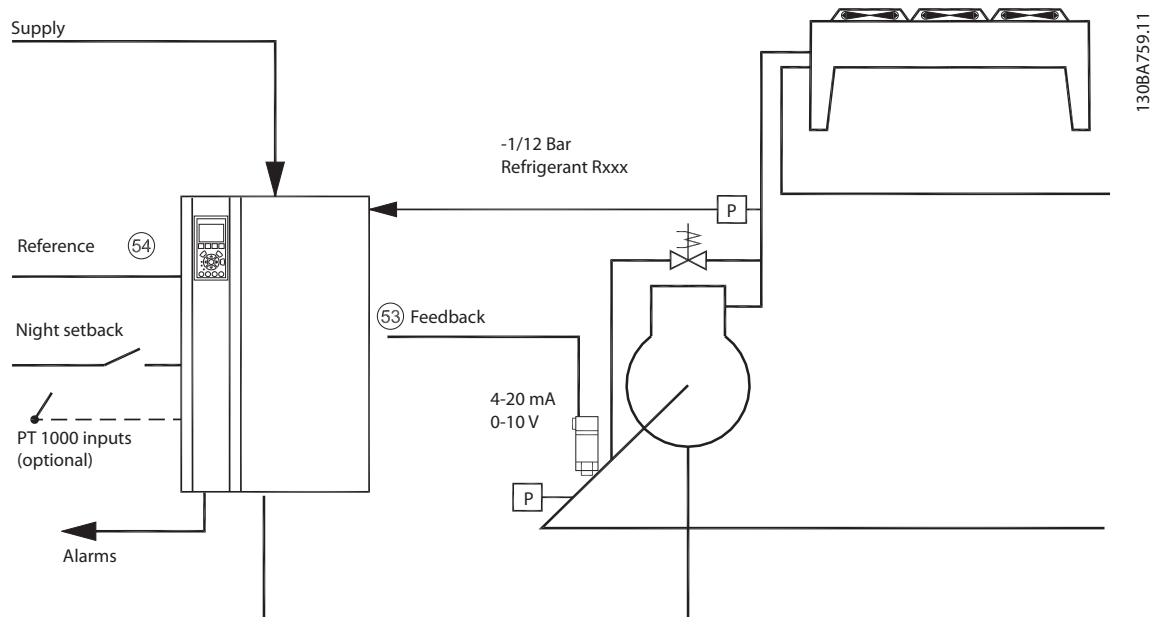

Illustration 7.1 Standard Drawing of "Compressor with Internal Control"

Wizard input:

- Bypass valve
- Recycling time (start to start)
- Min. Hz
- Max. Hz
- Setpoint
- Cut in/cut out
- 400/230 V AC
- Amps
- RPM

7.2.2 Single or Multiple Fans or Pumps

The wizard guides through the process of setting up of a refrigeration condenser fan or pump. Enter data about the condenser or pump and the refrigeration system on which the frequency converter will be running. All terminology and units used within the wizard are common refrigeration type and set -up is thus completed in 10-15 easy steps using just two keys on the LCP.

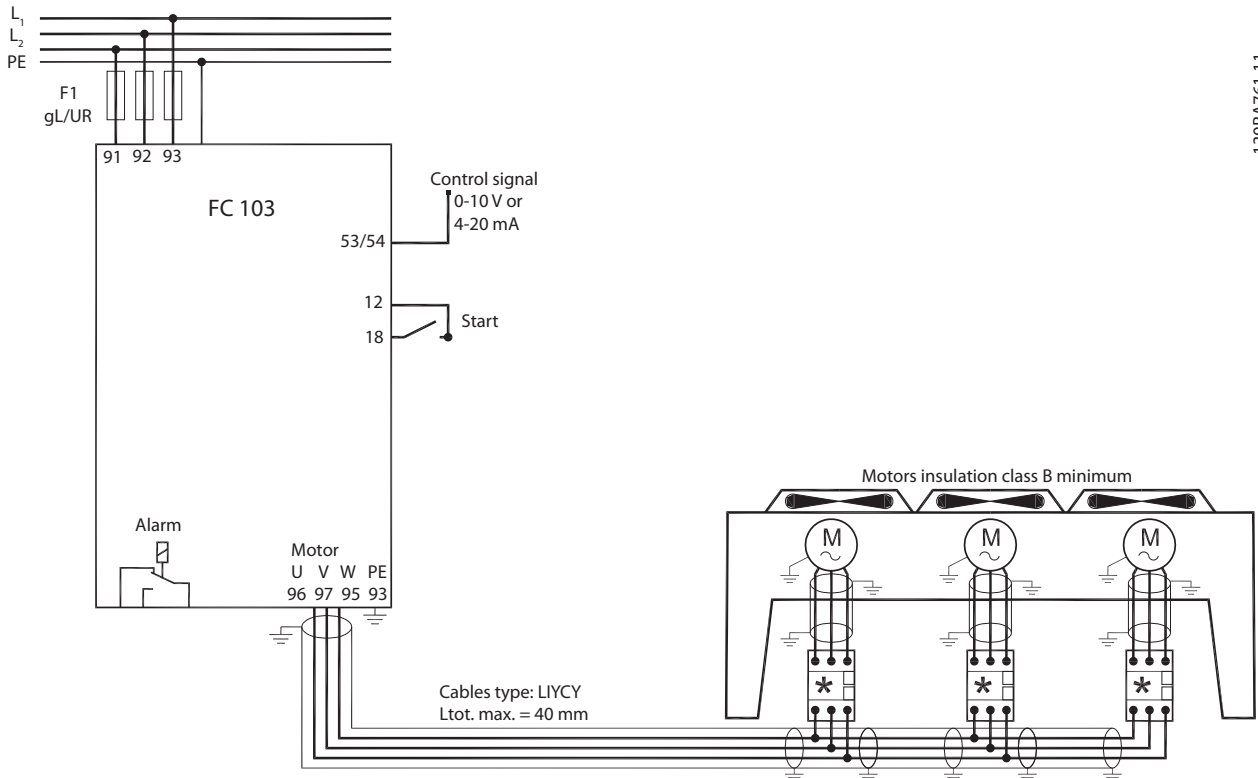

130BA761.11

7

Illustration 7.2 Speed Control Using Analogue Reference (Open Loop) – Single Fan or Pump/Multiple Fans or Pumps in Parallel

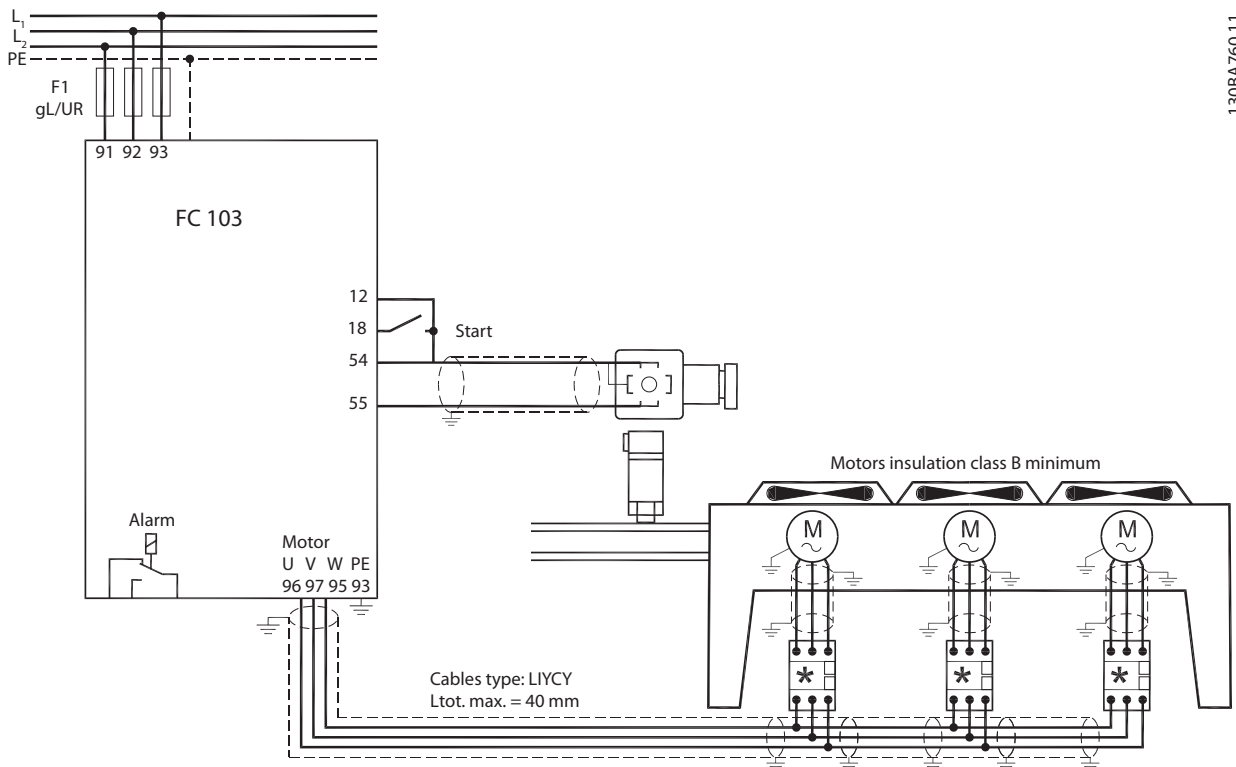

130BA760.11

Illustration 7.3 Pressure Control in Closed Loop – Stand Alone System - Single Fan or Pump/Multiple Fans or Pumps in Parallel

7.2.3 Compressor Pack

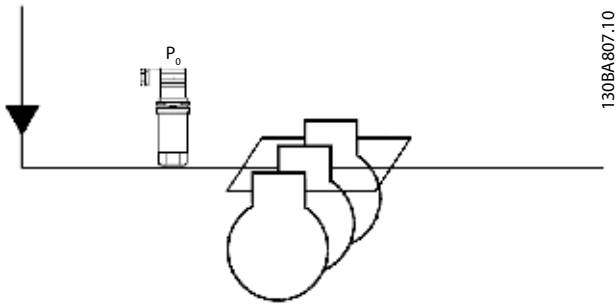

Illustration 7.4 P₀ Pressure Transmitter

7

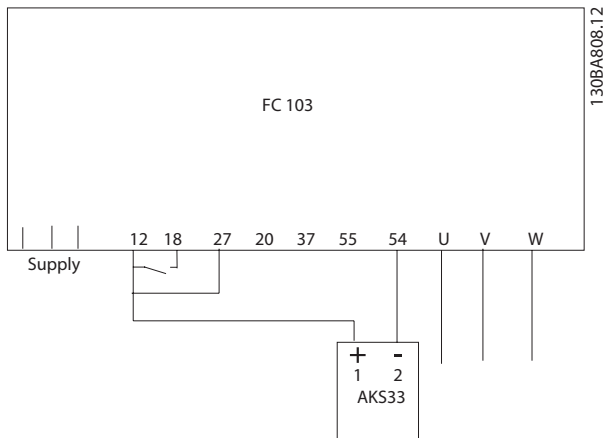

Illustration 7.5 How to Connect the FC 103 and AKS33 for Closed Loop Applications

NOTE

To find out which parameters are relevant, run the Wizard.

8 Status Messages

8.1 Status Display

When the frequency converter is in status mode, status messages are generated automatically from within the frequency converter and appear in the bottom line of the display (see *Illustration 8.1.*)

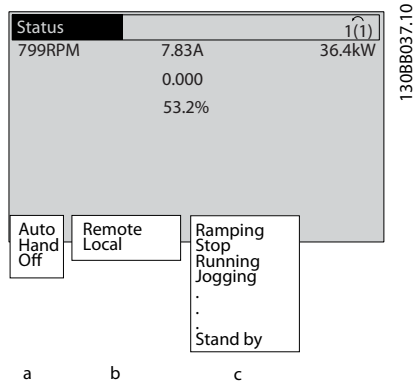

Illustration 8.1 Status Display

- The first part of the status line indicates where the stop/start command originates.
- The second part of the status line indicates where the speed control originates.
- The last part of the status line gives the present frequency converter status. These show the operational mode the frequency converter is in.

NOTE

In auto/remote mode, the frequency converter requires external commands to execute functions.

8.2 Status Message Definitions Table

The next three tables define the meaning of the status message display words.

	Operation mode
Off	The frequency converter does not react to any control signal until [Auto On] or [Hand On] is pressed.
Auto on	The frequency converter is controlled from the control terminals and/or the serial communication.
Hand on	The frequency converter can be controlled by the navigation keys on the LCP. Stop commands, reset, reversing, DC brake, and other signals applied to the control terminals can override local control.

Table 8.1

	Reference site
Remote	The speed reference is given from external signals, serial communication, or internal preset references.
Local	The frequency converter uses [Hand On] control or reference values from the LCP.

Table 8.2

	Operation status
AC Brake	AC Brake was selected in 2-10 Brake Function. The AC brake over-magnetizes the motor to achieve a controlled slow down.
AMA finish OK	Automatic motor adaptation (AMA) was carried out successfully.
AMA ready	AMA is ready to start. Press [Hand On] to start.
AMA running	AMA process is in progress.
Braking	The brake chopper is in operation. Generative energy is absorbed by the brake resistor.
Braking max.	The brake chopper is in operation. The power limit for the brake resistor defined in 2-12 Brake Power Limit (kW) is reached.
Coast	<ul style="list-style-type: none"> Coast inverse was selected as a function for a digital input (parameter group 5-1*). The corresponding terminal is not connected. Coast activated by serial communication

	Operation status
Ctrl. Ramp-down	Control Ramp-down was selected in <i>14-10 Mains Failure</i> . <ul style="list-style-type: none"> The mains voltage is below the value set in <i>14-11 Mains Voltage at Mains Fault at mains fault</i> The frequency converter ramps down the motor using a controlled ramp down
Current High	The frequency converter output current is above the limit set in <i>4-51 Warning Current High</i> .
Current Low	The frequency converter output current is below the limit set in <i>4-52 Warning Speed Low</i>
DC Hold	DC hold is selected in <i>1-80 Function at Stop</i> and a stop command is active. The motor is held by a DC current set in <i>2-00 DC Hold/ Preheat Current</i> .
DC Stop	The motor is held with a DC current (<i>2-01 DC Brake Current</i>) for a specified time (<i>2-02 DC Braking Time</i>). <ul style="list-style-type: none"> DC Brake is activated in <i>2-03 DC Brake Cut In Speed [RPM]</i> and a Stop command is active. DC Brake (inverse) is selected as a function for a digital input (parameter group 5-1*). The corresponding terminal is not active. The DC Brake is activated via serial communication.
Feedback high	The sum of all active feedbacks is above the feedback limit set in <i>4-57 Warning Feedback High</i> .
Feedback low	The sum of all active feedbacks is below the feedback limit set in <i>4-56 Warning Feedback Low</i> .
Freeze output	The remote reference is active, which holds the present speed. <ul style="list-style-type: none"> Freeze output was selected as a function for a digital input (parameter group 5-1*). The corresponding terminal is active. Speed control is only possible via the terminal functions speed up and speed down. Hold ramp is activated via serial communication.
Freeze output request	A freeze output command has been given, but the motor will remain stopped until a run permissive signal is received.
Freeze ref.	<i>Freeze Reference</i> was chosen as a function for a digital input (parameter group 5-1*). The corresponding terminal is active. The frequency converter saves the actual reference. Changing the reference is now only possible via terminal functions speed up and speed down.

	Operation status
Jog request	A jog command has been given, but the motor will be stopped until a run permissive signal is received via a digital input.
Jogging	The motor is running as programmed in <i>3-19 Jog Speed [RPM]</i> . <ul style="list-style-type: none"> <i>Jog</i> was selected as function for a digital input (parameter group 5-1*). The corresponding terminal (e.g. Terminal 29) is active. The Jog function is activated via the serial communication. The Jog function was selected as a reaction for a monitoring function (e.g. No signal). The monitoring function is active.
Motor check	In <i>1-80 Function at Stop, Motor Check</i> was selected. A stop command is active. To ensure that a motor is connected to the frequency converter, a permanent test current is applied to the motor.
OVC control	<i>Overvoltage</i> control was activated in <i>2-17 Overvoltage Control</i> . The connected motor is supplying the frequency converter with generative energy. The overvoltage control adjusts the V/Hz ratio to run the motor in controlled mode and to prevent the frequency converter from tripping.
PowerUnit Off	(For frequency converters with an external 24 V power supply installed only.) Mains supply to the frequency converter is removed, but the control card is supplied by the external 24 V.
Protection md	Protection mode is active. The unit has detected a critical status (an overcurrent or overvoltage). <ul style="list-style-type: none"> To avoid tripping, switching frequency is reduced to 4 kHz. If possible, protection mode ends after approximately 10 s. Protection mode can be restricted in <i>14-26 Trip Delay at Inverter Fault</i>
QStop	The motor is decelerating using <i>3-81 Quick Stop Ramp Time</i> . <ul style="list-style-type: none"> <i>Quick stop inverse</i> was chosen as a function for a digital input (parameter group 5-1*). The corresponding terminal is not active. The quick stop function was activated via serial communication.
Ramping	The motor is accelerating/decelerating using the active Ramp Up/Down. The reference, a limit value or a standstill is not yet reached.
Ref. high	The sum of all active references is above the reference limit set in <i>4-55 Warning Reference High</i> .

	Operation status
Ref. low	The sum of all active references is below the reference limit set in <i>4-54 Warning Reference Low</i> .
Run on ref.	The frequency converter is running in the reference range. The feedback value matches the setpoint value.
Run request	A start command has been given, but the motor is stopped until a run permissive signal is received via digital input.
Running	The motor is driven by the frequency converter.
Speed high	Motor speed is above the value set in <i>4-53 Warning Speed High</i> .
Speed low	Motor speed is below the value set in <i>4-52 Warning Speed Low</i> .
Standby	In Auto On mode, the frequency converter will start the motor with a start signal from a digital input or serial communication.
Start delay	In <i>1-71 Start Delay</i> , a delay starting time was set. A start command is activated and the motor will start after the start delay time expires.
Start fwd/rev	Start forward and start reverse were selected as functions for two different digital inputs (parameter group 5-1*). The motor will start in forward or reverse depending on which corresponding terminal is activated.
Stop	The frequency converter has received a stop command from the LCP, digital input or serial communication.
Trip	An alarm occurred and the motor is stopped. Once the cause of the alarm is cleared, the frequency converter can be reset manually by pressing [Reset] or remotely by control terminals or serial communication.
Trip lock	An alarm occurred and the motor is stopped. Once the cause of the alarm is cleared, power must be cycled to the frequency converter. The frequency converter can then be reset manually by pressing [Reset] or remotely by control terminals or serial communication.

Table 8.3

9 Warnings and Alarms

9.1 System Monitoring

The frequency converter monitors the condition of its input power, output, and motor factors as well as other system performance indicators. A warning or alarm may not necessarily indicate a problem internal to the frequency converter itself. In many cases, it indicates failure conditions from input voltage, motor load or temperature, external signals, or other areas monitored by the frequency converter's internal logic. Be sure to investigate those areas exterior to the frequency converter as indicated in the alarm or warning.

9.2 Warning and Alarm Types

9.2.1 Warnings

A warning is issued when an alarm condition is impending or when an abnormal operating condition is present and may result in the frequency converter issuing an alarm. A warning clears by itself when the abnormal condition is removed.

9.2.2 Alarm Trip

An alarm is issued when the frequency converter is tripped, that is, the frequency converter suspends operation to prevent frequency converter or system damage. The motor will coast to a stop. The frequency converter logic will continue to operate and monitor the frequency converter status. After the fault condition is remedied, the frequency converter can be reset. It will then be ready to start operation again.

A trip can be reset in any of 4 ways:

- Press [Reset]
- Digital reset input command
- Serial communication reset input command
- Auto reset

9.2.3 Alarm Trip-lock

An alarm that causes the frequency converter to trip-lock requires that input power be cycled. The motor will coast to a stop. The frequency converter logic will continue to operate and monitor the frequency converter status. Remove input power to the frequency converter and correct the cause of the fault, then restore power. This action puts the frequency converter into a trip condition as described above and may be reset in any of those 4 ways.

9.3 Warning and Alarm Displays

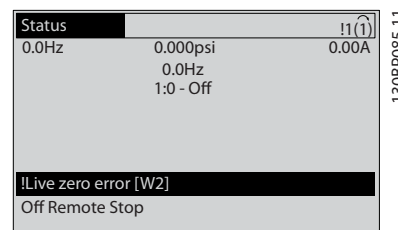

Illustration 9.1

An alarm or trip-lock alarm will flash on display along with the alarm number.

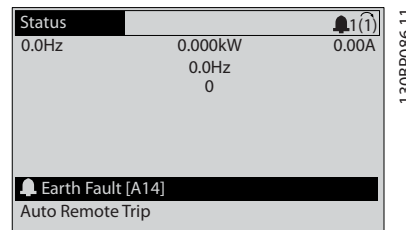
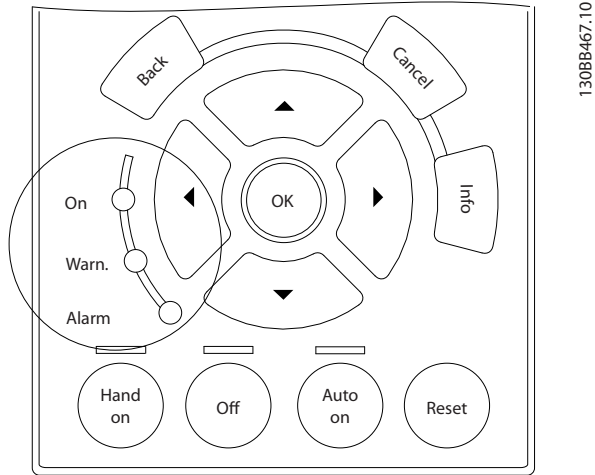

Illustration 9.2

In addition to the text and alarm code on the frequency converter display, there are three status indicator lights.



1308B467.10

Illustration 9.3

	Warn. LED	Alarm LED
Warning	ON	OFF
Alarm	OFF	ON (Flashing)
Trip-Lock	ON	ON (Flashing)

Table 9.1

9.4 Warning and Alarm Definitions

Table 9.2 defines whether a warning is issued prior to an alarm, and whether the alarm trips the unit or trip locks the unit.

No.	Description	Warning	Alarm/Trip	Alarm/Trip Lock	Parameter Reference
1	10 Volts low	X			
2	Live zero error	(X)	(X)		6-01 Live Zero Timeout Function
4	Mains phase loss	(X)	(X)	(X)	14-12 Function at Mains Imbalance
5	DC link voltage high	X			
6	DC link voltage low	X			
7	DC over voltage	X	X		
8	DC under voltage	X	X		
9	Inverter overloaded	X	X		
10	Motor over temperature	(X)	(X)		1-90 Motor Thermal Protection
11	Motor thermistor over temperature	(X)	(X)		1-90 Motor Thermal Protection
12	Torque limit	X	X		
13	Over Current	X	X	X	
14	Earth (ground) fault	X	X	X	
15	Hardware mismatch		X	X	
16	Short Circuit		X	X	
17	Control word timeout	(X)	(X)		8-04 Control Timeout Function
18	Start Failed				
23	Internal Fan Fault	X			
24	External Fan Fault	X			14-53 Fan Monitor
25	Brake resistor short-circuited	X			
26	Brake resistor power limit	(X)	(X)		2-13 Brake Power Monitoring
27	Brake chopper short-circuited	X	X		
28	Brake check	(X)	(X)		2-15 Brake Check
29	Drive over temperature	X	X	X	
30	Motor phase U missing	(X)	(X)	(X)	4-58 Missing Motor Phase Function
31	Motor phase V missing	(X)	(X)	(X)	4-58 Missing Motor Phase Function
32	Motor phase W missing	(X)	(X)	(X)	4-58 Missing Motor Phase Function
33	Inrush fault		X	X	
34	Fieldbus communication fault	X	X		
35	Out of frequency range	X	X		
36	Mains failure	X	X		
37	Phase Imbalance	X	X		
38	Internal fault		X	X	
39	Heatsink sensor		X	X	
40	Overload of Digital Output Terminal 27	(X)			5-00 Digital I/O Mode, 5-01 Terminal 27 Mode
41	Overload of Digital Output Terminal 29	(X)			5-00 Digital I/O Mode, 5-02 Terminal 29 Mode
42	Overload of Digital Output On X30/6	(X)			5-32 Term X30/6 Digi Out (MCB 101)
42	Overload of Digital Output On X30/7	(X)			5-33 Term X30/7 Digi Out (MCB 101)
46	Pwr. card supply		X	X	
47	24 V supply low	X	X	X	
48	1.8 V supply low		X	X	

No.	Description	Warning	Alarm/Trip	Alarm/Trip Lock	Parameter Reference
49	Speed limit	X	(X)		1-86 Compressor Min. Speed for Trip [RPM]
50	AMA calibration failed		X		
51	AMA check U _{nom} and I _{nom}		X		
52	AMA low I _{nom}		X		
53	AMA motor too big		X		
54	AMA motor too small		X		
55	AMA Parameter out of range		X		
56	AMA interrupted by user		X		
57	AMA timeout		X		
58	AMA internal fault	X	X		
59	Current limit	X			
60	External Interlock	X			
62	Output Frequency at Maximum Limit	X			
64	Voltage Limit	X			
65	Control Board Over-temperature	X	X	X	
66	Heat sink Temperature Low	X			
67	Option Configuration has Changed		X		
69	Pwr. Card Temp		X	X	
70	Illegal FC configuration			X	
71	PTC 1 Safe Stop	X	X ¹⁾		
72	Dangerous Failure			X ¹⁾	
73	Safe Stop Auto Restart				
76	Power Unit Setup	X			
77	Reduced Power Mode				
79	Illegal PS config		X	X	
80	Drive Initialized to Default Value		X		
91	Analog input 54 wrong settings			X	
92	NoFlow	X	X		22-2*
93	Dry Pump	X	X		22-2*
94	End of Curve	X	X		22-5*
95	Broken Belt	X	X		22-6*
96	Start Delayed	X			22-7*
97	Stop Delayed	X			22-7*
98	Clock Fault	X			0-7*
104	Mixing Fan Fault	X	X		14-53
203	Missing Motor				
204	Locked Rotor				
243	Brake IGBT	X	X		
244	Heatsink temp	X	X	X	
245	Heatsink sensor		X	X	
246	Pwr.card supply		X	X	
247	Pwr.card temp		X	X	
248	Illegal PS config		X	X	
250	New spare parts			X	
251	New Type Code		X	X	

Table 9.2 Alarm/Warning Code List
(X) Dependent on parameter
¹⁾ Cannot be Auto reset via 14-20 Reset Mode

9.5 Fault Messages

The warning/alarm information below defines each warning/alarm condition, provides the probable cause for the condition, and details a remedy or troubleshooting procedure.

WARNING 1, 10 Volts low

The control card voltage is below 10 V from terminal 50. Remove some of the load from terminal 50, as the 10 V supply is overloaded. Max. 15 mA or minimum 590 Ω.

This condition can be caused by a short in a connected potentiometer or improper wiring of the potentiometer.

Troubleshooting

Remove the wiring from terminal 50. If the warning clears, the problem is with the customer wiring. If the warning does not clear, replace the control card.

WARNING/ALARM 2, Live zero error

This warning or alarm only appears if programmed by the user in *6-01 Live Zero Timeout Function*. The signal on one of the analog inputs is less than 50% of the minimum value programmed for that input. Broken wiring or faulty device sending the signal can cause this condition.

Troubleshooting

- Check connections on all the analog input terminals. Control card terminals 53 and 54 for signals, terminal 55 common. MCB 101 terminals 11 and 12 for signals, terminal 10 common. MCB 109 terminals 1, 3, 5 for signals, terminals 2, 4, 6 common).
- Check that the frequency converter programming and switch settings match the analog signal type.
- Perform Input Terminal Signal Test.

WARNING/ALARM 3, No motor

No motor has been connected to the output of the frequency converter.

WARNING/ALARM 4, Mains phase loss

A phase is missing on the supply side, or the mains voltage imbalance is too high. This message also appears for a fault in the input rectifier on the frequency converter. Options are programmed at *14-12 Function at Mains Imbalance*.

Troubleshooting

Check the supply voltage and supply currents to the frequency converter.

WARNING 5, DC link voltage high

The intermediate circuit voltage (DC) is higher than the high voltage warning limit. The limit is dependent on the frequency converter voltage rating. The unit is still active.

WARNING 6, DC link voltage low

The intermediate circuit voltage (DC) is lower than the low voltage warning limit. The limit is dependent on the frequency converter voltage rating. The unit is still active.

WARNING/ALARM 7, DC overvoltage

If the intermediate circuit voltage exceeds the limit, the frequency converter trips after a time.

Troubleshooting

- Connect a brake resistor
- Extend the ramp time
- Change the ramp type
- Activate the functions in *2-10 Brake Function*
- Increase *14-26 Trip Delay at Inverter Fault*

WARNING/ALARM 8, DC under voltage

If the intermediate circuit voltage (DC link) drops below the under voltage limit, the frequency converter checks if a 24 V DC backup supply is connected. If no 24 V DC backup supply is connected, the frequency converter trips after a fixed time delay. The time delay varies with unit size.

Troubleshooting

- Check that the supply voltage matches the frequency converter voltage.
- Perform input voltage test.
- Perform soft charge circuit test.

WARNING/ALARM 9, Inverter overload

The frequency converter is about to cut out because of an overload (too high current for too long). The counter for electronic, thermal inverter protection gives a warning at 98% and trips at 100%, while giving an alarm. The frequency converter *cannot* be reset until the counter is below 90%.

The fault is that the frequency converter is overloaded by more than 100% for too long.

Troubleshooting

- Compare the output current shown on the LCP with the frequency converter rated current.
- Compare the output current shown on the LCP with measured motor current.
- Display the Thermal Drive Load on the LCP and monitor the value. When running above the frequency converter continuous current rating, the counter should increase. When running below the frequency converter continuous current rating, the counter should decrease.

WARNING/ALARM 10, Motor overload temperature

According to the electronic thermal protection (ETR), the motor is too hot. Select whether the frequency converter gives a warning or an alarm when the counter reaches 100% in *1-90 Motor Thermal Protection*. The fault occurs when the motor is overloaded by more than 100% for too long.

Troubleshooting

- Check for motor overheating.
- Check if the motor is mechanically overloaded

- Check that the motor current set in *1-24 Motor Current* is correct.
- Ensure that Motor data in parameters 1-20 through 1-25 are set correctly.
- If an external fan is in use, check in *1-91 Motor External Fan* that it is selected.
- Running AMA in *1-29 Automatic Motor Adaptation (AMA)* tunes the frequency converter to the motor more accurately and reduces thermal loading.

WARNING/ALARM 11, Motor thermistor over temp

The thermistor might be disconnected. Select whether the frequency converter gives a warning or an alarm in *1-90 Motor Thermal Protection*.

Troubleshooting

- Check for motor overheating.
- Check if the motor is mechanically overloaded.
- Check that the thermistor is connected correctly between either terminal 53 or 54 (analog voltage input) and terminal 50 (+10 V supply) and that the terminal switch for 53 or 54 is set for voltage. Check *1-93 Thermistor Source* selects terminal 53 or 54.
- When using digital inputs 18 or 19, check that the thermistor is connected correctly between either terminal 18 or 19 (digital input PNP only) and terminal 50.
- If a KTY sensor is used, check for correct connection between terminals 54 and 55
- If using a thermal switch or thermistor, check that the programming if *1-93 Thermistor Resource* matches sensor wiring.
- If using a KTY sensor, check the programming of *1-95 KTY Sensor Type*, *1-96 KTY Thermistor Resource*, and *1-97 KTY Threshold level* match sensor wiring.

WARNING/ALARM 12, Torque limit

The torque has exceeded the value in *4-16 Torque Limit Motor Mode* or the value in *4-17 Torque Limit Generator Mode*. *14-25 Trip Delay at Torque Limit* can change this from a warning only condition to a warning followed by an alarm.

Troubleshooting

- If the motor torque limit is exceeded during ramp up, extend the ramp up time.
- If the generator torque limit is exceeded during ramp down, extend the ramp down time.
- If torque limit occurs while running, possibly increase the torque limit. Be sure the system can operate safely at a higher torque.

- Check the application for excessive current draw on the motor.

WARNING/ALARM 13, Over current

The inverter peak current limit (approximately 200% of the rated current) is exceeded. The warning lasts about 1.5 secs., then the frequency converter trips and issues an alarm. This fault may be caused by shock loading or fast acceleration with high inertia loads. If extended mechanical brake control is selected, trip can be reset externally.

Troubleshooting

- Remove power and check if the motor shaft can be turned.
- Check that the motor size matches the frequency converter.
- Check parameters 1-20 through 1-25 for correct motor data.

ALARM 14, Earth (ground) fault

There is current from the output phases to earth, either in the cable between the frequency converter and the motor or in the motor itself.

Troubleshooting:

- Remove power to the frequency converter and repair the earth fault.
- Check for earth faults in the motor by measuring the resistance to ground of the motor leads and the motor with a megohmmeter.
- Perform current sensor test.

ALARM 15, Hardware mismatch

A fitted option is not operational with the present control board hardware or software.

Record the value of the following parameters and contact your Danfoss supplier:

- *15-40 FC Type*
- *15-41 Power Section*
- *15-42 Voltage*
- *15-43 Software Version*
- *15-45 Actual Typecode String*
- *15-49 SW ID Control Card*
- *15-50 SW ID Power Card*
- *15-60 Option Mounted*
- *15-61 Option SW Version* (for each option slot)

ALARM 16, Short circuit

There is short-circuiting in the motor or motor wiring.

Remove power to the frequency converter and repair the short circuit.

WARNING/ALARM 17, Control word timeout

There is no communication to the frequency converter.

The warning will only be active when *8-04 Control Timeout Function* is NOT set to OFF.

If *8-04 Control Timeout Function* is set to *Stop* and *Trip*, a warning appears and the frequency converter ramps down until it trips then displays an alarm.

Troubleshooting:

- Check connections on the serial communication cable.
- Increase *8-03 Control Timeout Time*
- Check the operation of the communication equipment.
- Verify a proper installation based on EMC requirements.

ALARM 18, Start failed

The speed has not been able to exceed *AP-70 Compressor Start Max Speed [RPM]* during start within the allowed time. (set in *AP-72 Compressor Start Max Time to Trip*). This may be caused by a blocked motor.

WARNING 23, Internal fan fault

The fan warning function is an extra protective function that checks if the fan is running/mounted. The fan warning can be disabled in *14-53 Fan Monitor ([0] Disabled)*.

For the D, E, and F Frame filters, the regulated voltage to the fans is monitored.

Troubleshooting

- Check fan resistance.
- Check soft charge fuses.

WARNING 24, External fan fault

The fan warning function is an extra protective function that checks if the fan is running/mounted. The fan warning can be disabled in *14-53 Fan Monitor ([0] Disabled)*.

Troubleshooting

- Check fan resistance.
- Check soft charge fuses.

WARNING 25, Brake resistor short circuit

The brake resistor is monitored during operation. If a short circuit occurs, the brake function is disabled and the warning appears. The frequency converter is still operational but without the brake function. Remove power to the frequency converter and replace the brake resistor (see *2-15 Brake Check*).

WARNING/ALARM 26, Brake resistor power limit

The power transmitted to the brake resistor is calculated as a mean value over the last 120 s of run time. The calculation is based on the intermediate circuit voltage and the brake resistance value set in *2-16 AC brake Max. Current*. The warning is active when the dissipated braking is higher than 90% of the brake resistance power. If *[2] Trip* is selected in *2-13 Brake Power Monitoring*, the frequency converter will trip when the dissipated braking power reaches 100%.

⚠ WARNING

There is a risk of substantial power being transmitted to the brake resistor if the brake transistor is short-circuited.

WARNING/ALARM 27, Brake chopper fault

The brake transistor is monitored during operation and if a short circuit occurs, the brake function is disabled and a warning is issued. The frequency converter is still operational but, since the brake transistor has short-circuited, substantial power is transmitted to the brake resistor, even if it is inactive. Remove power to the frequency converter and remove the brake resistor.

This alarm/warning could also occur should the brake resistor overheat. Terminals 104 and 106 are available as brake resistors Klixon inputs.

WARNING/ALARM 28, Brake check failed

The brake resistor is not connected or not working. Check *2-15 Brake Check*.

ALARM 29, Heatsink temp

The maximum temperature of the heatsink has been exceeded. The temperature fault will not reset until the temperature falls below a defined heatsink temperature. The trip and reset points are different based on the frequency converter power size.

Troubleshooting

Check for the following conditions.

- Ambient temperature too high.
- Motor cable too long.
- Incorrect airflow clearance above and below the frequency converter
- Blocked airflow around the frequency converter.
- Damaged heatsink fan.
- Dirty heatsink.

For the D, E, and F Frame sizes, this alarm is based on the temperature measured by the heatsink sensor mounted inside the IGBT modules. For the F Frame sizes, this alarm can also be caused by the thermal sensor in the Rectifier module.

Troubleshooting

- Check fan resistance.
- Check soft charge fuses.
- IGBT thermal sensor.

ALARM 30, Motor phase U missing

Motor phase U between the frequency converter and the motor is missing.

Remove power from the frequency converter and check motor phase U.

ALARM 31, Motor phase V missing

Motor phase V between the frequency converter and the motor is missing.

Remove power from the frequency converter and check motor phase V.

ALARM 32, Motor phase W missing

Motor phase W between the frequency converter and the motor is missing.

Remove power from the frequency converter and check motor phase W.

ALARM 33, Inrush fault

Too many power-ups have occurred within a short time period. Let the unit cool to operating temperature.

WARNING/ALARM 34, Fieldbus communication fault

The fieldbus on the communication option card is not working.

WARNING/ALARM 36, Mains failure

This warning/alarm is only active if the supply voltage to the frequency converter is lost and *14-10 Mains Failure* is NOT set to [0] *No Function*. Check the fuses to the frequency converter and mains power supply to the unit.

ALARM 38, Internal fault

When an internal fault occurs, a code number defined in the table below is displayed.

Troubleshooting

- Cycle power
- Check that the option is properly installed
- Check for loose or missing wiring

It may be necessary to contact your Danfoss supplier or service department. Note the code number for further troubleshooting directions.

No.	Text
0	Serial port cannot be initialised. Contact your Danfoss supplier or Danfoss Service Department.
256-258	Power EEPROM data is defective or too old.
512	Control board EEPROM data is defective or too old.
513	Communication time out reading EEPROM data
514	Communication time out reading EEPROM data
515	Application oriented control cannot recognize the EEPROM data.
516	Cannot write to the EEPROM because a write command is on progress.
517	Write command is under time out
518	Failure in the EEPROM
519	Missing or invalid barcode data in EEPROM
783	Parameter value outside of min/max limits
1024-1279	A centelegram that has to be sent couldn't be sent.
1281	Digital signal processor flash timeout
1282	Power micro software version mismatch
1283	Power EEPROM data version mismatch
1284	Cannot read digital signal processor software version
1299	Option SW in slot A is too old

No.	Text
1300	Option SW in slot B is too old
1301	Option SW in slot C0 is too old
1302	Option SW in slot C1 is too old
1315	Option SW in slot A is not supported (not allowed)
1316	Option SW in slot B is not supported (not allowed)
1317	Option SW in slot C0 is not supported (not allowed)
1318	Option SW in slot C1 is not supported (not allowed)
1379	Option A did not respond when calculating platform version
1380	Option B did not respond when calculating platform version
1381	Option C0 did not respond when calculating platform version.
1382	Option C1 did not respond when calculating platform version.
1536	An exception in the application oriented control is registered. Debug information written in LCP
1792	DSP watchdog is active. Debugging of power part data, motor oriented control data not transferred correctly.
2049	Power data restarted
2064-2072	H081x: option in slot x has restarted
2080-2088	H082x: option in slot x has issued a powerup-wait
2096-2104	H983x: option in slot x has issued a legal powerup-wait
2304	Could not read any data from power EEPROM
2305	Missing SW version from power unit
2314	Missing power unit data from power unit
2315	Missing SW version from power unit
2316	Missint lo_statepage from power unit
2324	Power card configuration is determined to be incorrect at power up
2325	A power card has stopped communicating while main power is applied
2326	Power card configuration is determined to be incorrect after the delay for power cards to register.
2327	Too many power card locations have been registered as present.
2330	Power size information between the power cards does not match.
2561	No communication from DSP to ATACD
2562	No communication from ATACD to DSP (state running)
2816	Stack overflow control board module
2817	Scheduler slow tasks
2818	Fast tasks
2819	Parameter thread
2820	LCP stack overflow
2821	Serial port overflow
2822	USB port overflow
2836	cfListMempool too small

No.	Text
3072-5122	Parameter value is outside its limits
5123	Option in slot A: Hardware incompatible with control board hardware
5124	Option in slot B: Hardware incompatible with Control board hardware.
5125	Option in slot C0: Hardware incompatible with control board hardware.
5126	Option in slot C1: Hardware incompatible with control board hardware.
5376-6231	Out of memory

Table 9.3

ALARM 39, Heatsink sensor

No feedback from the heatsink temperature sensor.

The signal from the IGBT thermal sensor is not available on the power card. The problem could be on the power card, on the gate drive card, or the ribbon cable between the power card and gate drive card.

WARNING 40, Overload of digital output terminal 27

Check the load connected to terminal 27 or remove short-circuit connection. Check *5-00 Digital I/O Mode* and *5-01 Terminal 27 Mode*.

WARNING 41, Overload of digital output terminal 29

Check the load connected to terminal 29 or remove short-circuit connection. Check *5-00 Digital I/O Mode* and *5-02 Terminal 29 Mode*.

WARNING 42, Overload of digital output on X30/6 or overload of digital output on X30/7

For X30/6, check the load connected to X30/6 or remove the short-circuit connection. Check *5-32 Term X30/6 Digi Out (MCB 101)*.

For X30/7, check the load connected to X30/7 or remove the short-circuit connection. Check *5-33 Term X30/7 Digi Out (MCB 101)*.

ALARM 46, Power card supply

The supply on the power card is out of range.

There are three power supplies generated by the switch mode power supply (SMPS) on the power card: 24 V, 5 V, ±18 V. When powered with 24 V DC with the MCB 107 option, only the 24 V and 5 V supplies are monitored. When powered with three phase mains voltage, all three supplies are monitored.

WARNING 47, 24 V supply low

The 24 V DC is measured on the control card. The external 24 V DC backup power supply may be overloaded, otherwise contact your Danfoss supplier.

WARNING 48, 1.8 V supply low

The 1.8 V DC supply used on the control card is outside of allowable limits. The power supply is measured on the control card. Check for a defective control card. If an option card is present, check for an overvoltage condition.

WARNING 49, Speed limit

When the speed is not within the specified range in *4-11 Motor Speed Low Limit [RPM]* and *4-13 Motor Speed High Limit [RPM]*, the frequency converter shows a warning. When the speed is below the specified limit in *1-86 Compressor Min. Speed for Trip [RPM]* (except when starting or stopping) the frequency converter will trip.

ALARM 50, AMA calibration failed

Contact your Danfoss supplier or Danfoss Service Department.

ALARM 51, AMA check U_{nom} and I_{nom}

The settings for motor voltage, motor current, and motor power are wrong. Check the settings in parameters 1-20 to 1-25.

ALARM 52, AMA low I_{nom}

The motor current is too low. Check the settings.

ALARM 53, AMA motor too big

The motor is too big for the AMA to operate.

ALARM 54, AMA motor too small

The motor is too small for the AMA to operate.

ALARM 55, AMA Parameter out of range

The parameter values of the motor are outside of the acceptable range. AMA will not run.

56 ALARM, AMA interrupted by user

The user has interrupted the AMA.

ALARM 57, AMA internal fault

Try to restart AMA again a number of times, until the AMA is carried out. Note that repeated runs may heat the motor to a level where the resistance R_s and R_r are increased. In most cases, however, this is not critical.

ALARM 58, AMA internal fault

Contact your Danfoss supplier.

WARNING 59, Current limit

The current is higher than the value in *4-18 Current Limit*. Ensure that Motor data in parameters 1-20 through 1-25 are set correctly. Possibly increase the current limit. Be sure that the system can operate safely at a higher limit.

WARNING 60, External interlock

External interlock has been activated. To resume normal operation, apply 24 V DC to the terminal programmed for external interlock and reset the frequency converter (via serial communication, digital I/O, or by pressing [Reset]).

WARNING/ALARM 61, Tracking error

An error between calculated motor speed and speed measurement from feedback device. The function Warning/Alarm/Disable is set in *4-30 Motor Feedback Loss Function*. Accepted error setting in *4-31 Motor Feedback Speed Error* and the allowed time the error occur setting in *4-32 Motor Feedback Loss Timeout*. During a commissioning procedure the function may be effective.

WARNING 62, Output frequency at maximum limit

The output frequency is higher than the value set in *4-19 Max Output Frequency*.

ALARM 64, Voltage Limit

The load and speed combination demands a motor voltage higher than the actual DC link voltage.

WARNING/ALARM 65, Control card over temperature

The cutout temperature of the control card is 80° C.

Troubleshooting

- Check that the ambient operating temperature is within limits
- Check for clogged filters
- Check fan operation
- Check the control card

WARNING 66, Heatsink temperature low

The frequency converter is too cold to operate. This warning is based on the temperature sensor in the IGBT module.

Increase the ambient temperature of the unit. Also, a trickle amount of current can be supplied to the frequency converter whenever the motor is stopped by setting *2-00 DC Hold/Preheat Current* at 5% and *1-80 Function at Stop*

Troubleshooting

The heatsink temperature measured as 0° C could indicate that the temperature sensor is defective, causing the fan speed to increase to the maximum. If the sensor wire between the IGBT and the gate drive card is disconnected, this warning would result. Also, check the IGBT thermal sensor.

ALARM 67, Option module configuration has changed

One or more options have either been added or removed since the last power-down. Check that the configuration change is intentional and reset the unit.

ALARM 68, Safe Stop activated

Safe stop has been activated. To resume normal operation, apply 24 V DC to terminal 37, then send a reset signal (via Bus, Digital I/O, or by pressing the reset key).

ALARM 69, Power card temperature

The temperature sensor on the power card is either too hot or too cold.

Troubleshooting

- Check the operation of the door fans.
- Check that the filters for the door fans are not blocked.
- Check that the gland plate is properly installed on IP21/IP 54 (NEMA 1/12) frequency converters.

ALARM 70, Illegal frequency converter configuration

The control card and power card are incompatible. Contact your supplier with the type code of the unit from the nameplate and the part numbers of the cards to check compatibility.

ALARM 72, Dangerous failure

Safe Stop with Trip Lock. Unexpected signal levels on safe stop and digital input from the MCB 112 PTC thermistor card.

WARNING 73, Safe stop auto restart

Safe stopped. With automatic restart enabled, the motor may start when the fault is cleared.

WARNING 76, Power unit setup

The required number of power units does not match the detected number of active power units.

Troubleshooting:

When replacing an F-frame module, this will occur if the power specific data in the module power card does not match the rest of the frequency converter. Please confirm the spare part and its power card are the correct part number.

77 WARNING, Reduced power mode

This warning indicates that the frequency converter is operating in reduced power mode (i.e. less than the allowed number of inverter sections). This warning will be generated on power cycle when the frequency converter is set to run with fewer inverters and will remain on.

ALARM 79, Illegal power section configuration

The scaling card is the incorrect part number or not installed. Also MK102 connector on the power card could not be installed.

ALARM 80, Drive initialised to default value

Parameter settings are initialised to default settings after a manual reset. Reset the unit to clear the alarm.

ALARM 81, CSIV corrupt

CSIV file has syntax errors.

ALARM 82, CSIV parameter error

CSIV failed to init a parameter.

WARNING/ALARM 104, Mixing fan fault

The fan monitor checks that the fan is spinning at drive power-up or whenever the mixing fan is turned on. If the fan is not operating, then the fault is annunciated. The mixing-fan fault can be configured as a warning or an alarm trip by *14-53 Fan Monitor*.

Troubleshooting

Cycle power to the frequency converter to determine if the warning/alarm returns.

WARNING 250, New spare part

A component in the frequency converter has been replaced. Reset the frequency converter for normal operation.

WARNING 251, New typecode

The power card or other components have been replaced and the typecode changed. Reset to remove the warning and resume normal operation.

10 Basic Troubleshooting

10.1 Start Up and Operation

Symptom	Possible Cause	Test	Solution
Display dark / No function	Missing input power	See <i>Table 4.1</i> .	Check the input power source.
	Missing or open fuses or circuit breaker tripped	See open fuses and tripped circuit breaker in this table for possible causes.	Follow the recommendations provided
	No power to the LCP	Check the LCP cable for proper connection or damage.	Replace the faulty LCP or connection cable.
	Shortcut on control voltage (terminal 12 or 50) or at control terminals	Check the 24 V control voltage supply for terminal 12/13 to 20-39 or 10 V supply for terminal 50 to 55.	Wire the terminals properly.
	Wrong LCP (LCP from VLT® 2800 or 5000/6000/8000/ FCD or FCM)		Use only LCP 101 (P/N 130B1124) or LCP 102 (P/N 130B1107).
	Wrong contrast setting		Press [Status] + [▲]/[▼] to adjust the contrast.
	Display (LCP) is defective	Test using a different LCP.	Replace the faulty LCP or connection cable.
	Internal voltage supply fault or SMPS is defective		Contact supplier.
Intermittent display	Overloaded power supply (SMPS) due to improper control wiring or a fault within the frequency converter	To rule out a problem in the control wiring, disconnect all control wiring by removing the terminal blocks.	If the display stays lit, then the problem is in the control wiring. Check the wiring for shorts or incorrect connections. If the display continues to cut out, follow the procedure for display dark.
Motor not running	Service switch open or missing motor connection	Check if the motor is connected and the connection is not interrupted (by a service switch or other device).	Connect the motor and check the service switch.
	No mains power with 24 V DC option card	If the display is functioning but no output, check that mains power is applied to the frequency converter.	Apply mains power to run the unit.
	LCP Stop	Check if [Off] has been pressed.	Press [Auto On] or [Hand On] (depending on operation mode) to run the motor.
	Missing start signal (Standby)	Check <i>5-10 Terminal 18 Digital Input</i> for correct setting for terminal 18 (use default setting).	Apply a valid start signal to start the motor.
	Motor coast signal active (Coasting)	Check <i>5-12 Coast inv.</i> for correct setting for terminal 27 (use default setting).	Apply 24 V on terminal 27 or program this terminal to <i>No operation</i> .
	Wrong reference signal source	Check reference signal: Local, remote or bus reference? Preset reference active? Terminal connection correct? Scaling of terminals correct? Reference signal available?	Program correct settings. Check <i>3-13 Reference Site</i> . Set preset reference active in parameter group <i>3-1* References</i> . Check for correct wiring. Check scaling of terminals. Check reference signal.

10

Symptom	Possible Cause	Test	Solution
Motor running in wrong direction	Motor rotation limit	Check that <i>4-10 Motor Speed Direction</i> is programmed correctly.	Program correct settings.
	Active reversing signal	Check if a reversing command is programmed for the terminal in parameter group <i>5-1* Digital inputs</i> .	Deactivate reversing signal.
	Wrong motor phase connection		See in this manual.
Motor is not reaching maximum speed	Frequency limits set wrong	Check output limits in <i>4-13 Motor Speed High Limit [RPM]</i> , <i>4-14 Motor Speed High Limit [Hz]</i> and <i>4-19 Max Output Frequency</i>	Program correct limits.
	Reference input signal not scaled correctly	Check reference input signal scaling in <i>6-* Analog I/O mode</i> and parameter group <i>3-1* References</i> . Reference limits in parameter group <i>3-0*</i> .	Program correct settings.
Motor speed unstable	Possible incorrect parameter settings	Check the settings of all motor parameters, including all motor compensation settings. For closed loop operation, check PID settings.	Check settings in parameter group <i>1-6* Analog I/O mode</i> . For closed loop operation, check settings in parameter group <i>20-0* Feedback</i> .
Motor runs rough	Possible over-magnetization	Check for incorrect motor settings in all motor parameters.	Check motor settings in parameter groups <i>1-2* Motor data</i> , <i>1-3* Adv motor data</i> , and <i>1-5* Load indep. setting</i> .
Motor will not brake	Possible incorrect settings in the brake parameters. Possible too short ramp down times.	Check brake parameters. Check ramp time settings.	Check parameter group <i>2-0* DC brake</i> and <i>3-0* Reference limits</i> .
Open power fuses or circuit breaker trip	Phase to phase short	Motor or panel has a short phase to phase. Check motor and panel phase for shorts.	Eliminate any shorts detected.
	Motor overload	Motor is overloaded for the application.	Perform startup test and verify motor current is within specifications. If motor current is exceeding nameplate full load current, motor may run only with reduced load. Review the specifications for the application.
	Loose connections	Perform pre-startup check for loose connections.	Tighten loose connections.
Mains current imbalance greater than 3%	Problem with mains power (See <i>Alarm 4 Mains phase loss</i> description)	Rotate input power leads into the frequency converter one position: A to B, B to C, C to A.	If imbalanced leg follows the wire, it is a power problem. Check mains power supply.
	Problem with the frequency converter	Rotate input power leads into the frequency converter one position: A to B, B to C, C to A.	If imbalance leg stays on same input terminal, it is a problem with the unit. Contact the supplier.
Motor current imbalance greater than 3%	Problem with motor or motor wiring	Rotate output motor leads one position: U to V, V to W, W to U.	If imbalanced leg follows the wire, the problem is in the motor or motor wiring. Check motor and motor wiring.
	Problem with the frequency converters	Rotate output motor leads one position: U to V, V to W, W to U.	If imbalance leg stays on same output terminal, it is a problem with the unit. Contact the supplier.

Symptom	Possible Cause	Test	Solution
Acoustic noise or vibration (e.g. a fan blade is making noise or vibrations at certain frequencies)	Resonances, e.g. in the motor/fan system	Bypass critical frequencies by using parameters in parameter group 4-6*.	Check if noise and/or vibration have been reduced to an acceptable limit.
		Turn off over-modulation in 14-03 <i>Overmodulation</i> .	
		Change switching pattern and frequency in parameter group 14-0*.	
		Increase Resonance Dampening in 1-64 <i>Resonance Dampening</i> .	

Table 10.1

11 Specifications

11.1 General Specifications

Mains supply (L1, L2, L3)

Supply voltage	380-480 V ±10%
Supply voltage	525-600 V ±10%

Mains voltage low/mains drop-out:

During low mains voltage or a mains drop-out, the frequency converter continues until the intermediate circuit voltage drops below the minimum stop level, which corresponds typically to 15% below the frequency converter's lowest rated supply voltage. Power-up and full torque cannot be expected at mains voltage lower than 10% below the frequency converter's lowest rated supply voltage.

Supply frequency	50/60 Hz ±5%
Max. imbalance temporary between mains phases	3.0 % of rated supply voltage
True Power Factor (λ)	≥ 0.9 nominal at rated load
Displacement Power Factor ($\cos\phi$) near unity	(> 0.98)
Switching on input supply L1, L2, L3 (power-ups)	maximum once/2 min.
Environment according to EN60664-1	overvoltage category III / pollution degree 2

The unit is suitable for use on a circuit capable of delivering not more than 100.000 RMS symmetrical Amperes, 480/600 V maximum.

Motor output (U, V, W)

Output voltage	0-100% of supply voltage
Output frequency	0-800* Hz
Switching on output	Unlimited
Ramp times	1-3600 s

* Voltage and power dependent

Torque characteristics

Starting torque (Constant torque)	maximum 110% for 1 min.*
Starting torque	maximum 135% up to 0.5 s*
Overload torque (Constant torque)	maximum 110% for 1 min.*

*Percentage relates to the frequency converter's nominal torque.

Cable lengths and cross sections

Max. motor cable length, screened/armoured	150 m
Max. motor cable length, unscreened/unarmoured	300 m
Max. cross section to motor, mains, load sharing and brake *	
Maximum cross section to control terminals, rigid wire	1.5 mm ² /16 AWG (2x0.75 mm ²)
Maximum cross section to control terminals, flexible cable	1 mm ² /18 AWG
Maximum cross section to control terminals, cable with enclosed core	0.5 mm ² /20 AWG
Minimum cross section to control terminals	0.25 mm ²

* See 11.2.1 Mains Supply 3x380-480 VAC - High Power for more information!

Digital inputs

Programmable digital inputs	4 (6)
Terminal number	18, 19, 27 ¹⁾ , 29 ¹⁾ , 32, 33,
Logic	PNP or NPN
Voltage level	0-24 V DC
Voltage level, logic '0' PNP	<5 V DC
Voltage level, logic '1' PNP	>10 V DC
Voltage level, logic '0' NPN	>19 V DC
Voltage level, logic '1' NPN	<14 V DC
Maximum voltage on input	28 V DC
Input resistance, R _i	approx. 4 kΩ

All digital inputs are galvanically isolated from the supply voltage (PELV) and other high-voltage terminals.

1) Terminals 27 and 29 can also be programmed as output.

Analog inputs

Number of analog inputs	2
Terminal number	53, 54
Modes	Voltage or current
Mode select	Switch S201 and switch S202
Voltage mode	Switch S201/switch S202 = OFF (U)
Voltage level	0 to +10 V (scaleable)
Input resistance, R _i	approx. 10 kΩ
Max. voltage	±20 V
Current mode	Switch S201/switch S202 = ON (I)
Current level	0/4 to 20 mA (scaleable)
Input resistance, R _i	approx. 200 Ω
Max. current	30 mA
Resolution for analog inputs	10 bit (+ sign)
Accuracy of analog inputs	Max. error 0.5% of full scale
Bandwidth	200 Hz

The analog inputs are galvanically isolated from the supply voltage (PELV) and other high-voltage terminals.

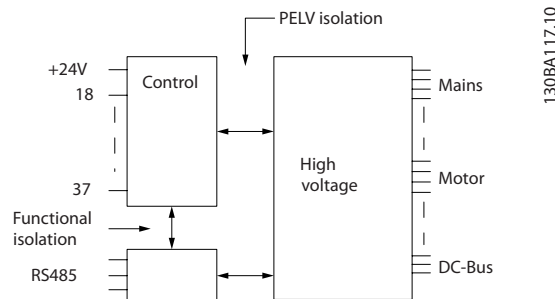

Illustration 11.1

Pulse inputs

Programmable pulse inputs	2
Terminal number pulse	29, 33
Max. frequency at terminal, 29, 33	110 kHz (Push-pull driven)
Max. frequency at terminal, 29, 33	5 kHz (open collector)
Min. frequency at terminal 29, 33	4 Hz
Voltage level	see 11.1.1 <i>Digital Inputs</i>
Maximum voltage on input	28 V DC
Input resistance, R_i	approx. 4 k Ω
Pulse input accuracy (0.1-1 kHz)	Max. error: 0.1% of full scale

Analog output

Number of programmable analog outputs	1
Terminal number	42
Current range at analog output	0/4-20 mA
Max. resistor load to common at analog output	500 Ω
Accuracy on analog output	Max. error: 0.8% of full scale
Resolution on analog output	8 bit

The analog output is galvanically isolated from the supply voltage (PELV) and other high-voltage terminals.

Control card, RS-485 serial communication

Terminal number	68 (P,TX+, RX+), 69 (N,TX-, RX-)
Terminal number 61	Common for terminals 68 and 69

The RS-485 serial communication circuit is functionally seated from other central circuits and galvanically isolated from the supply voltage (PELV).

Digital output

Programmable digital/pulse outputs	2
Terminal number	27, 29 ¹⁾
Voltage level at digital/frequency output	0-24 V
Max. output current (sink or source)	40 mA
Max. load at frequency output	1 k Ω
Max. capacitive load at frequency output	10 nF
Minimum output frequency at frequency output	0 Hz
Maximum output frequency at frequency output	32 kHz
Accuracy of frequency output	Max. error: 0.1% of full scale
Resolution of frequency outputs	12 bit

1) Terminal 27 and 29 can also be programmed as input.

The digital output is galvanically isolated from the supply voltage (PELV) and other high-voltage terminals.

Control card, 24 V DC output

Terminal number	12, 13
Max. load	200 mA

The 24 V DC supply is galvanically isolated from the supply voltage (PELV), but has the same potential as the analog and digital inputs and outputs.

Relay outputs

Programmable relay outputs	2
Relay 01 Terminal number	1-3 (break), 1-2 (make)
Max. terminal load (AC-1) ¹⁾ on 1-3 (NC), 1-2 (NO) (Resistive load)	240 V AC, 2 A
Max. terminal load (AC-15) ¹⁾ (Inductive load @ $\cos\phi$ 0.4)	240 V AC, 0.2 A
Max. terminal load (DC-1) ¹⁾ on 1-2 (NO), 1-3 (NC) (Resistive load)	60 V DC, 1 A
Max. terminal load (DC-13) ¹⁾ (Inductive load)	24 V DC, 0.1 A
Relay 02 Terminal number	4-6 (break), 4-5 (make)
Max. terminal load (AC-1) ¹⁾ on 4-5 (NO) (Resistive load) ²⁾³⁾	400 V AC, 2 A
Max. terminal load (AC-15) ¹⁾ on 4-5 (NO) (Inductive load @ $\cos\phi$ 0.4)	240 V AC, 0.2 A
Max. terminal load (DC-1) ¹⁾ on 4-5 (NO) (Resistive load)	80 V DC, 2 A
Max. terminal load (DC-13) ¹⁾ on 4-5 (NO) (Inductive load)	24 V DC, 0.1 A

Max. terminal load (AC-1) ¹⁾ on 4-6 (NC) (Resistive load)	240 V AC, 2 A
Max. terminal load (AC-15) ¹⁾ on 4-6 (NC) (Inductive load @ cosφ 0.4)	240 V AC, 0.2 A
Max. terminal load (DC-1) ¹⁾ on 4-6 (NC) (Resistive load)	50 V DC, 2 A
Max. terminal load (DC-13) ¹⁾ on 4-6 (NC) (Inductive load)	24 V DC, 0.1 A
Min. terminal load on 1-3 (NC), 1-2 (NO), 4-6 (NC), 4-5 (NO)	24 V DC 10 mA, 24 V AC 20 mA
Environment according to EN 60664-1	overvoltage category III/pollution degree 2

1) IEC 60947 parts 4 and 5

The relay contacts are galvanically isolated from the rest of the circuit by reinforced isolation (PELV).

2) Overvoltage Category II

3) UL applications 300 V AC 2 A

Control card, 10 V DC output

Terminal number	50
Output voltage	10.5 V ±0.5 V
Max. load	25 mA

The 10 V DC supply is galvanically isolated from the supply voltage (PELV) and other high-voltage terminals.

Control characteristics

Resolution of output frequency at 0-1000 Hz	±0.003 Hz
System response time (terminals 18, 19, 27, 29, 32, 33)	≤ 2 ms
Speed control range (open loop)	1:100 of synchronous speed
Speed accuracy (open loop)	30-4000 rpm: Maximum error of ±8 rpm

All control characteristics are based on a 4-pole asynchronous motor

Surroundings

Enclosure, frame size D and E	IP00, IP21, IP54
Enclosure, frame size F	IP21, IP54
Vibration test	0.7 g
Relative humidity	5% - 95%(IEC 721-3-3; Class 3K3 (non-condensing) during operation
Aggressive environment (IEC 60068-2-43) H ₂ S test	class kD
Test method according to IEC 60068-2-43 H ₂ S (10 days)	
Ambient temperature (at 60 AVM switching mode)	
- with derating	max. 55 °C ¹⁾
- with full output power, typical EFF2 motors	max. 50 °C ¹⁾
- at full continuous FC output current	max. 45 °C ¹⁾

¹⁾ For more information on derating see the Design Guide, section on Special Conditions.

Minimum ambient temperature during full-scale operation	0 °C
Minimum ambient temperature at reduced performance	-10 °C
Temperature during storage/transport	-25 to +65/70 °C
Maximum altitude above sea level without derating	1000 m
Maximum altitude above sea level with derating	3000 m

Derating for high altitude, see section on special conditions in the Design Guide

EMC standards, Emission	EN 61800-3, EN 61000-6-3/4, EN 55011, IEC 61800-3 EN 61800-3, EN 61000-6-1/2,
EMC standards, Immunity	EN 61000-4-2, EN 61000-4-3, EN 61000-4-4, EN 61000-4-5, EN 61000-4-6

See section on special conditions in the Design Guide!

Control card performance

Scan interval	5 ms
Control card, USB serial communication	
USB standard	1.1 (Full speed)
USB plug	USB type B "device" plug

CAUTION

Connection to PC is carried out via a standard host/device USB cable.

The USB connection is galvanically isolated from the supply voltage (PELV) and other high-voltage terminals.

The USB connection is not galvanically isolated from protection earth. Use only isolated laptop/PC as connection to the USB connector on the frequency converter or an isolated USB cable/converter.

Protection and Features

- Electronic thermal motor protection against overload.
- Temperature monitoring of the heatsink ensures that the frequency converter trips if the temperature reaches a predefined level. An overload temperature cannot be reset until the temperature of the heatsink is below the values stated in the tables on the following pages (Guideline - these temperatures may vary for different power sizes, frame sizes, enclosure ratings etc.).
- The frequency converter is protected against short-circuits on motor terminals U, V, W.
- If a mains phase is missing, the frequency converter trips or issues a warning (depending on the load).
- Monitoring of the intermediate circuit voltage ensures that the frequency converter trips if the intermediate circuit voltage is too low or too high.
- The frequency converter is protected against earth faults on motor terminals U, V, W.

11.2 Mains Supply

	P110	P132	P160	P200	P250
Typical Shaft output at 400 V [kW]	110	132	160	200	250
Typical Shaft output at 460 V [HP]	150	200	250	300	350
Enclosure IP21	D1	D1	D2	D2	D2
Enclosure IP54	D1	D1	D2	D2	D2
Enclosure IP00	D3	D3	D4	D4	D4
Output current					
Continuous (at 400 V) [A]	212	260	315	395	480
Intermittent (60 s overload) (at 400 V) [A]	233	286	347	435	528
Continuous (at 460/480 V) [A]	190	240	302	361	443
Intermittent (60 s overload) (at 460/480 V) [A]	209	264	332	397	487
Continuous KVA (at 400 V) [KVA]	147	180	218	274	333
Continuous KVA (at 460 V) [KVA]	151	191	241	288	353
Continuous (at 400 V) [A]	204	251	304	381	463
Continuous (at 460/480 V) [A]	183	231	291	348	427
Max. cable size, mains motor, brake and load share [mm ² (AWG ²⁾]	2 x 70 (2 x 2/0)	2 x 70 (2 x 2/0)	2 x 150 (2 x 300 mcm)	2 x 150 (2 x 300 mcm)	2 x 150 (2 x 300 mcm)
Max. external pre-fuses [A] ¹	300	350	400	500	630
Estimated power loss at rated max. load [W] ⁴⁾ , 400 V	3234	3782	4213	5119	5893
Estimated power loss at rated max. load [W] ⁴⁾ , 460 V	2947	3665	4063	4652	5634
Weight, enclosure IP21, IP54 [kg]	96	104	125	136	151
Weight, enclosure IP00 [kg]	82	91	112	123	138
Efficiency ⁴⁾	0.98				
Output frequency	0-800 Hz				
Heatsink overtemp. trip	90 °C	110°C	110 °C	110 °C	110 °C
Power card ambient trip	60 °C				

Table 11.1 Mains Supply 3x380-480 VAC

	P132	P160	P200	P250
Typical Shaft output at 550 V [kW]	110	132	160	200
Typical Shaft output at 575 V [HP]	150	200	250	300
Typical Shaft output at 600 V [kW]	132	160	200	250
Enclosure IP21	D1	D1	D2	D2
Enclosure IP54	D1	D1	D2	D2
Enclosure IP00	D3	D3	D4	D4
Output current				
Continuous (at 550 V) [A]	162	201	253	303
Intermittent (60 s overload) (at 550 V) [A]	178	221	278	333
Continuous (at 575/600 V) [A]	155	192	242	290
Intermittent (60 s overload) (at 575/600 V) [A]	171	211	266	319
Continuous KVA (at 550 V) [KVA]	154	191	241	289
Continuous KVA (at 575 V) [KVA]	154	191	241	289
Continuous KVA (at 600 V) [KVA]	185	229	289	347
Continuous (at 550 V) [A]	158	198	245	299
Continuous (at 575 V) [A]	151	189	234	286
Continuous (at 600 V) [A]	155	197	240	296
Max. cable size, mains motor, load share and brake [mm ² (AWG)]	2 x 70 (2 x 2/0)	2 x 70 (2 x 2/0)	2 x 150 (2 x 300 mcm)	2 x 150 (2 x 300 mcm)
Max. external pre-fuses [A] ¹	315	350	350	400
Estimated power loss at rated max. load [W] ⁴ , 600 V	2963	3430	4051	4867
Estimated power loss at rated max. load [W] ⁴ , 600 V	3430	3612	4292	5156
Weight, Enclosure IP21, IP54 [kg]	96	104	125	136
Weight, Enclosure IP00 [kg]	82	91	112	123
Efficiency ⁴	0.98			
Output frequency	0-600 Hz			
Heatsink overtemp. trip	90 °C	110 °C	110 °C	110 °C
Power card ambient trip	60 °C			

Table 11.2 Mains Supply 3x525-600 V AC

- 1) For type of fuse see 11.3 Fuse Specifications
- 2) American Wire Gauge.
- 3) Measured using 5 m screened motor cables at rated load and rated frequency.
- 4) The typical power loss is at nominal load conditions and expected to be within ±15% (tolerance relates to variety in voltage and cable conditions). Values are based on a typical motor efficiency (eff2/eff3 border line). Motors with lower efficiency will also add to the power loss in the frequency converter and opposite. If the switching frequency is increased come to the default setting, the power losses may rise significantly. LCP and

typical control card power consumptions are included. Further options and customer load may add up to 30 W to the losses. (Though typical only 4 W extra for a fully loaded control card, or options for slot A or slot B, each). Although measurements are made with state of the art equipment, some measurement inaccuracy must be allowed for ($\pm 5\%$).

11.3 Fuse Specifications

11.3.1 Protection

Branch Circuit Protection:

In order to protect the installation against electrical and fire hazard, all branch circuits in an installation, switch gear, machines etc., must be short-circuited and over-current protected according to national/international regulations.

Short-circuit Protection:

The frequency converter must be protected against short-circuit to avoid electrical or fire hazard. Danfoss recommends using the fuses mentioned below to protect service personnel and equipment in case of an internal failure in the frequency converter. The frequency converter provides full short-circuit protection in case of a short-circuit on the motor output.

Over-current Protection:

Provide overload protection to avoid fire hazard due to overheating of the cables in the installation. The frequency converter is equipped with an internal over-current protection that can be used for upstream overload protection (UL-applications excluded). See *4-18 Current Limit*. Moreover, fuses or circuit breakers can be used to provide the over-current protection in the installation. Over-current protection must always be carried out according to national regulations.

11.3.2 Non UL Compliance

If UL/cUL is not to be complied with, we recommend using the following fuses, which will ensure compliance with EN50178. In case of malfunction, not following the recommendation may result in unnecessary damage to the frequency converter.

N110 - N250	380 - 500 V	type gG
N315	380 - 500 V	type gR

Table 11.3

11.3.3 UL Compliance

380-500 V: The fuses below are suitable for use on a circuit capable of delivering 100,000 Arms (symmetrical), With the proper fusing, the drive Short Circuit Current Rating (SCCR) is 100,000 Arms.

Power Size	Fuse Options							
	Bussman PN	Littelfuse PN	Littelfuse PN	Bussmann PN	Siba PN	Ferraz-Shawmut PN	Ferraz-Shawmut PN (Europe)	Ferraz-Shawmut PN (North America)
N110	170M2619	LA50QS300-4	L50S-300	FWH-300A	20 610 31.315	A50QS300-4	6,9URD31D08A0315	A070URD31KI0315
N132	170M2620	LA50QS350-4	L50S-350	FWH-350A	20 610 31.350	A50QS350-4	6,9URD31D08A0350	A070URD31KI0350
N160	170M2621	LA50QS400-4	L50S-400	FWH-400A	20 610 31.400	A50QS400-4	6,9URD31D08A0400	A070URD31KI0400
N200	170M4015	LA50QS500-4	L50S-500	FWH-500A	20 610 31.550	A50QS500-4	6,9URD31D08A0550	A070URD31KI0550
N250	170M4016	LA50QS600-4	L50S-600	FWH-600A	20 610 31.630	A50QS600-4	6,9URD31D08A0630	A070URD31KI0630
N315	170M4017	LA50QS800-4	L50S-800	FWH-800A	20 610 31.800	A50QS800-4	6,9URD32D08A0800	A070URD31KI0800

Table 11.4 Alternative Fuse Options

11.3.4 Connection Tightening Torques

When tightening all electrical connections it is very important to tighten with the correct torque. Too low or too high torque results in a bad electrical connection. Use a torque wrench to ensure correct torque. Always use a torque wrench to tighten the bolts.

11

Frame Size	Terminal	Torque	Bolt size
D1h/D3h	Mains Motor Load sharing Regen	19-40 Nm (168-354 in-lbs)	M10
	Earth (Ground) Brake	8.5-20.5 Nm (75-181 in-lbs)	M8
D2h/D4h	Mains Motor Regen Load sharing Earth (ground)	19-40 Nm (168-354 in-lbs)	M10
	Brake	8.5-20.5 Nm (75-181 in-lbs)	M8

Table 11.5 Torque for Terminals

Index

A

AC

Input..... 6, 17
 Mains..... 6
 Mains Input Connection..... 17
 Waveform..... 6

Airflow..... 9

Alarm

Log..... 31
 Trip..... 50

Alarm/Warning Code List..... 53

AMA..... 55, 58

Analog

Inputs..... 19, 54, 64
 Output..... 19, 65
 Signal..... 54

Auto

Auto..... 32
 Mode..... 31
 On..... 47, 32, 49

Automatic Motor Adaptation..... 47

Auto-reset..... 30

B

Braking..... 56, 47

C

Cable Lengths And Cross Sections..... 63

Circuit Breakers..... 21

Commissioning..... 21

Communication Option..... 57

Conduit..... 11, 21

Connection Tightening Torques..... 72

Control

Cables..... 18
 Card..... 54
 Card Performance..... 67
 Card, 10 V DC Output..... 66
 Card, 24 V DC Output..... 65
 Card, RS-485 Serial Communication..... 65
 Card, USB Serial Communication..... 67
 Characteristics..... 66
 Signal..... 34, 35, 47
 System..... 6
 Terminal Functions..... 19
 Terminal Types..... 19
 Terminals..... 28, 32, 47, 49, 35, 19
 Wiring..... 10, 11, 12, 21
 Wiring Connection..... 18

Cooling

Cooling..... 8
 Clearance..... 21

Copying Parameter Settings..... 32

Current

Limit..... 28
 Rating..... 8, 54

D

DC

Current..... 6, 48
 Link..... 54
 Voltage..... 6

Derating..... 8

Digital

Input..... 19, 49, 55
 Inputs..... 49, 36, 64
 Output..... 65

Discharge Time..... 4

Disconnect Switch..... 22

Downloading Data From The LCP..... 33

Duct Cooling..... 8

E

Earth

Connections..... 12, 21
 Loops..... 18
 Wire..... 21

Earthing

Earthing..... 21
 (grounding) Hazard..... 12
 (Grounding) IP20 Enclosures..... 13
 (Grounding) IP21/54 Enclosures..... 13
 (Grounding) Of Screened Control Cables..... 18

Electrical

Installation..... 9
 Noise..... 12

EMC..... 18, 21

Equalizing Cable..... 18

Exploded Views..... 5

External

Commands..... 7, 47
 Controllers..... 6
 Interlock..... 36
 Voltage..... 34

F

Fault Log..... 31

Feedback..... 21, 58, 48

Floating Delta..... 17

Frequency Converter Block Diagram..... 6

Full Load Current..... 8

Functional Testing..... 6, 29

Fuse Specifications..... 71

Fuses..... 21, 57, 60

Fusing..... 11, 21

G

Ground

- Connections..... 12, 21
- Loops..... 18
- Wire..... 12, 21

Grounded Delta..... 17

Grounding..... 12, 21

H

Hand

- Hand..... 32
- On..... 47, 28, 32

Harmonics..... 6

I

IEC 61800-3..... 17

Induced Voltage..... 11

Initialisation..... 33

Input

- Current..... 17
- Power..... 10, 12, 21, 50, 60, 7
- Signal..... 35
- Signals..... 19
- Terminals..... 54
- Voltage..... 22, 50

Installation

- Installation..... 6, 11, 21, 8, 22
- Site..... 8

Isolated Mains..... 17

L

Leakage Current (>3.5 MA)..... 12

Lifting..... 9

Local

- Control..... 30, 32, 47
- Control Panel..... 30
- Mode..... 28
- Operation..... 30
- Start..... 28

M

Main Menu..... 34, 31

Mains

- Mains..... 11
- Supply (L1, L2, L3)..... 63
- Supply 3 X 525- 690 VAC..... 69
- Voltage..... 31, 32, 48

Manual Initialisation..... 33

MCT 10 Set-up Software..... 19

Mechanical Installation..... 8

Menu

- Keys..... 30, 31
- Structure..... 32, 38

Motor

- Cable..... 17
- Cables..... 11, 14
- Connection..... 14
- Current..... 7, 58, 31
- Data..... 28, 55, 58
- Frequency..... 31
- Output..... 63
- Power..... 11, 12, 58, 31
- Protection..... 11, 67
- Rotation..... 31
- Rotation Check..... 17
- Speeds..... 27
- Status..... 6
- Wiring..... 10, 11, 21

Mounting..... 21

Multiple Frequency Converters..... 11, 14

N

Navigation Keys..... 27, 34, 47, 30, 32

Noise Isolation..... 10, 21

O

Open Loop..... 34

Operation Keys..... 32

Optional Equipment..... 22, 6

Output

- Current..... 48, 54
- Performance (U, V, W)..... 63
- Signal..... 37

Overcurrent..... 48

Overload Protection..... 8, 11

Overvoltage..... 28, 48

P

Parameter Settings..... 32

PELV..... 18

Phase Loss..... 54

Power

- Connections..... 11
- Factor..... 6, 14, 21

Pre-Installation Checklist..... 8

Programming..... 6, 29, 31, 36, 37, 54, 30, 32

Protection

- Protection..... 71
- And Features..... 67

Pulse Inputs..... 65

Q		Terminal	
Quick		53.....	34
Menu.....	31, 34, 36, 31	Locations D1h.....	14
Set-up.....	28	Locations D2h.....	15
		Programming.....	19
		Programming Examples.....	35
R		Thermistor	
Ramp-down Time	28	Thermistor.....	18, 55
Ramp-up Time	28	Control Wiring.....	18
Reference	4, 44, 47, 48, 31	Torque	
Relay Outputs	19, 65	Characteristics.....	63
Remote		For Terminals.....	72
Commands.....	6	Limit.....	28
Reference.....	48	Transient Protection	6
Reset	30, 33, 49, 50, 54, 59, 32	Trip Function	11
Residual Current Devices (RCDs)	12	Troubleshooting	6, 54, 60
Restoring Default Settings	33		
RFI Filter	17	U	
RMS Current	6	Uploading Data To The LCP	33
RS-485	19	User Interface	30
Run		Using Screened Control Cables	18
Command.....	29		
Permissive.....	48	V	
		Voltage	
S		Imbalance.....	54
Screened Control Cables	18	Level.....	64
Serial Communication	6, 18, 19, 32, 47, 48, 49, 50, 19, 67	W	
Set Up	31	Warnings And Alarms	50
Setpoint	49	Wire Type And Ratings	11
Set-up	31	Wiring To Control Terminals	19
Shielded			
Cable.....	10, 21		
Wire.....	11		
Short Circuit	55		
Specifications	6, 63		
Speed Reference	29, 35, 47		
Start Up	6, 33, 34, 60		
Status			
Messages.....	47		
Mode.....	47		
Stop Command	48		
Supply Voltage	18, 19, 57		
Surroundings	66		
Switching Frequency	48		
System Feedback	6		
T			
Temperature Limits	21		



www.danfoss.com/drives

Danfoss can accept no responsibility for possible errors in catalogues, brochures and other printed material. Danfoss reserves the right to alter its products without notice. This also applies to products already on order provided that such alterations can be made without consequential changes being necessary in specifications already agreed. All trademarks in this material are property of the respective companies. Danfoss and the Danfoss logotype are trademarks of Danfoss A/S. All rights reserved.

