

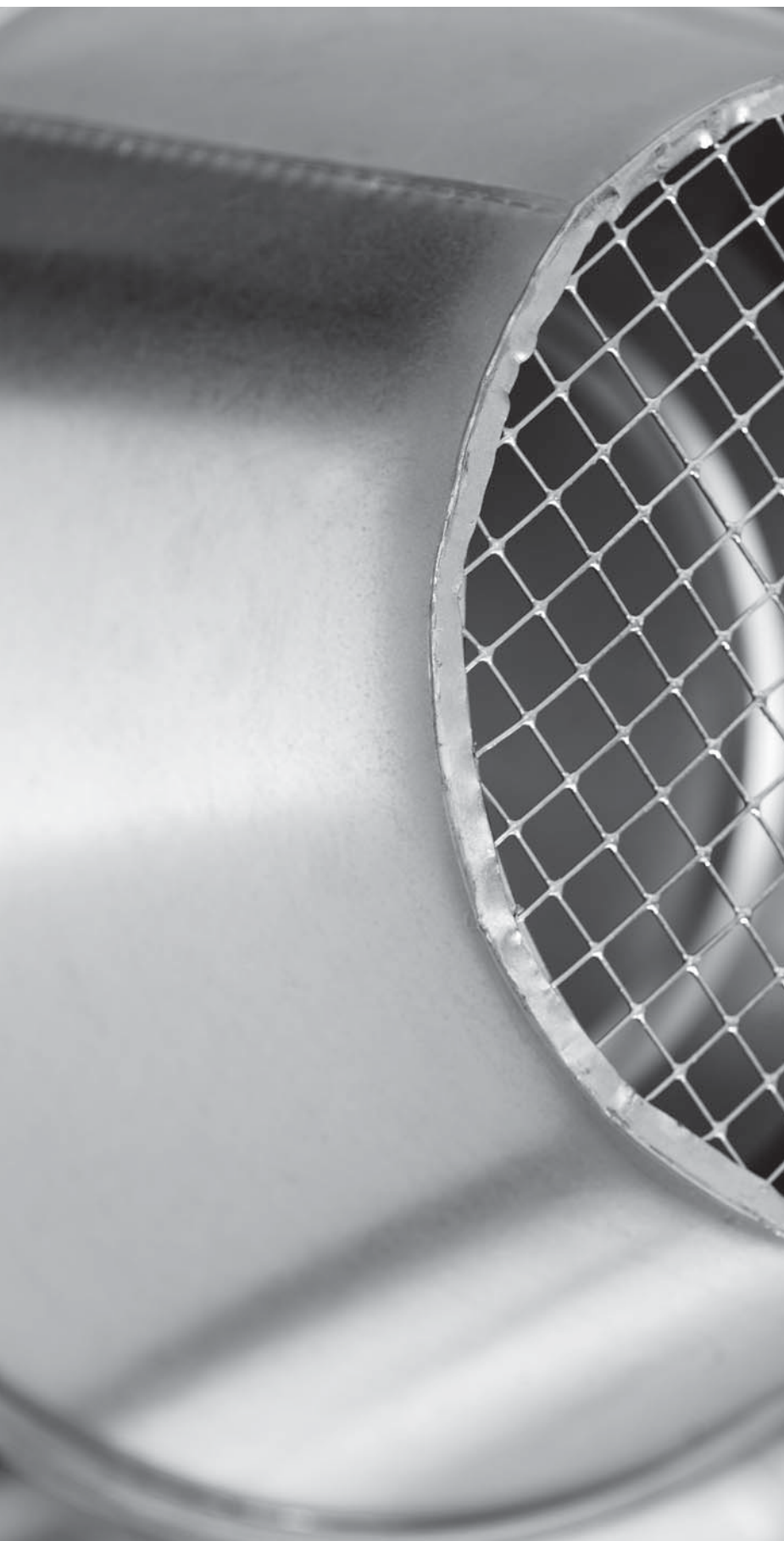













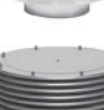

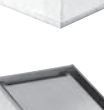
# Roof hoods

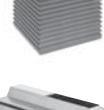

Lindab	1
General information and theory	2
Safe	3
Silencers	4
Dampers & Measure units	5
Fire dampers & Smoke evacuation	6
Air valves	7
<b>Roof hoods</b>	<b>8</b>
Other circular products	9
Transfer	10
Rectangular	11
Flexible ducting	12
Isol	13
Access doors	14
Smart tools	15
Duct suspensions & Support systems	16
Fastening material	17
Index	18

# Content – Roof hoods

1	<b>Roof hoods</b>	H .....	446
2			
3		HV .....	448
4		HU .....	450
5		HN .....	452
6		HF .....	454
7		VHL .....	455
8		VHL .....	458
9		HRR .....	459
10		HVR .....	461
11		LHR .....	463
12			
13			
14		HKOMR .....	466
15	<b>Roof transitions</b>		
16		TGR .....	469
17		TGKOMR .....	472
18			

<b>Membrane lead-through</b>	
	MG..... 474
	MGL..... 475

# Roof hoods

## General

**Extract air** – All Lindab's roof hoods are suitable for use as extract air hoods. When choosing extract air hood, the architectural design is important to ensure that the hood is in harmony with the rest of the building. Our range includes ribbed hoods, rectangular and circular roof hoods, models that are available with inclines adapted to the angle of the roof, as well as products with a horizontal profile, of course. If a high extract velocity and long ejection distance are required, choose our HN and HF roof hoods.

NOTE! When fans are not running there is always a risk for drifting snow and damp to penetrate into ducts. At some occasions also condensation can cause trouble.

**Outdoor air** – Out of Lindab's range of roof hoods, HN and HF are not suitable as outdoor air hoods. When choosing outdoor air hoods, too, the architectural design is important to ensure that it is in harmony with the rest of the building. Lindab's range of outdoor air hoods includes the same design as for extract air hoods (see above).

**Connection options** – Connection to a sleeve, flange or directly to the roof through connection must always be specified where these alternatives are possible. The recommended roof through connection is specified for each hood.

## Dimensioning

**Extract air** – If high extract velocities are not required, as low a pressure drop as possible is desirable. The pressure drop should not exceed 100 Pa in order to minimise self-generated noise emissions and energy consumption.

**Outdoor air** – When outdoor air hoods are used, there is always a risk of water and snow entering the duct. In order to minimise this risk, the velocity over the free area must not exceed 2 m/s.

**Location** – When locating roof hoods, the design of the roof should be taken into consideration to ensure that there are no 'snow pockets'. The hoods must also be positioned so that extract fumes from vehicles etc. cannot be drawn into the outdoor air hood. In the same way, it is necessary to avoid short-circuits arising between outdoor air and extract air. If there is a risk of short-circuits, our combination hood HKOMR should be chosen in the first instance.

**Noise** – To avoid self-generated noise emissions, the pressure drop must not exceed 100 Pa. At this pressure drop, self-generated noise emissions are so low that they do not need to be added to the fan noise. To calculate noise to the surrounding environment, the calculation example shown to the right can be used.

## Version

**Material** – Lindab's roof hoods are manufactured as follows.

Galvanised sheet metal, aluzink sheet AZ185, stainless steel sheet 1.4301, stainless acid-resistant steel sheet 1.4404 and painted as detailed below.

With these alternatives we cover up to and including corrosion class C5.

**Painting** – We have 3 standard colours (see below) but can also supply other colours to specification.

**Standard colours** – Black 015 RAL 9005, brick red 742 RAL 8004, zinc grey 244 RAL 7040.

However, this does not apply to VHL and LHR, where black RAL 9005 and grey RAL 7024 are the standard colours.

## Noise dispersion outdoors without obstacle

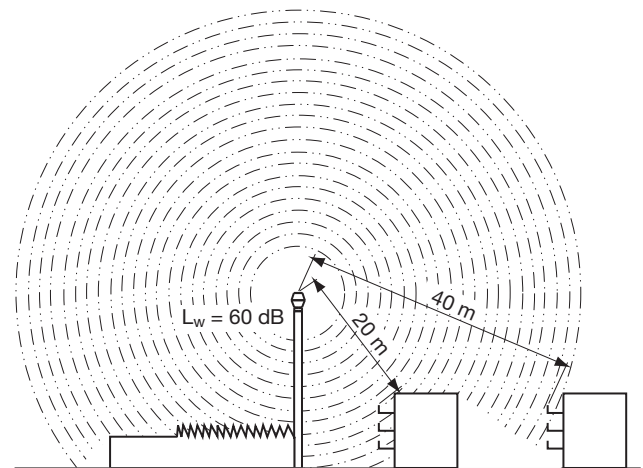

$L_w$  = Sound power level radiated from sound source [dB]

$r$  = Distance from sound source to point of listening [m]

$L_p$  = Sound pressure level at point of listening [dB]

$Q$  = Direction factor [-]

1 = in free field, far from all surfaces

2 = on one surface

4 = in the corner between two surfaces

8 = in the corner between three surfaces

$$L_p = L_w - 10 \cdot \log \left( \frac{4 \cdot \pi \cdot r^2}{Q} \right)$$

$$L_p = 60 - 10 \cdot \log \left( \frac{4 \cdot \pi \cdot 20^2}{1} \right) = 23 \text{ dB}$$

$$L_p = 60 - 10 \cdot \log \left( \frac{4 \cdot \pi \cdot 40^2}{1} \right) = 17 \text{ dB}$$

# Roof hoods

## Example – Noise from roof hood

**Conditions** – A level of 60 dB(A) has been measured 10 metres from an existing roof hood, the noise output level of which we do not know.

This is now to be moved, and we want to know the sound pressure level 30 metres from its new location closer to a vertical wall surface. We assume that the noise from the fan is unchanged in the two cases.

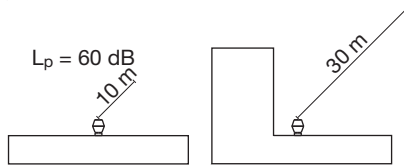

First you extract the sound power level  $L_W$  from the equation above.

$$L_W = L_p + 10 \cdot \log \left( \frac{4 \cdot \pi \cdot r^2}{Q} \right)$$

$$L_W = 60 + 10 \cdot \log \left( \frac{4 \cdot \pi \cdot 10^2}{2} \right) = 88 \text{ dB}$$

I.e. the radiated sound power level  $L_W$  from the hood = 88 dB.

$$L_p = L_W - 10 \cdot \log \left( \frac{4 \cdot \pi \cdot r^2}{Q} \right)$$

$$L_p = 88 - 10 \cdot \log \left( \frac{4 \cdot \pi \cdot 30^2}{4} \right) = 53 \text{ dB}$$

I.e. the sound pressure level at 30 m distance from the new location is 53 dB.

# Roof hoods

## Products used for penetration of roof

Prinipal sketch

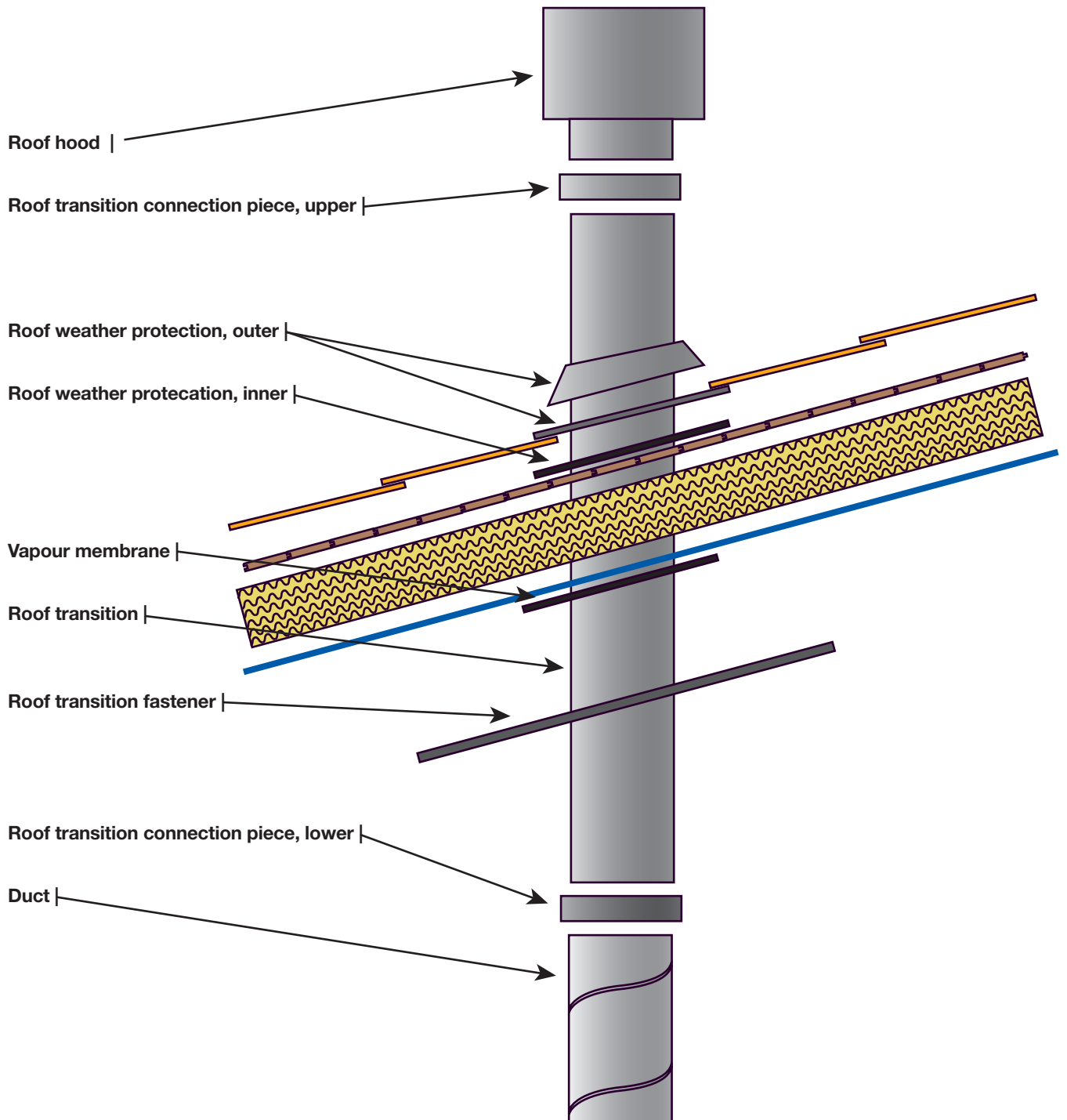



## Description

Circular roof hood intended for outdoor air and extract air. The hood is designed for location above the roof with or without a roof through connection. The air runs both on the top- and downside of the hood. This is valid both for outdoor and extract air. The hood is free-draining downwards. Can also be supplied with a pest-proof mesh.

NOTE! When fans are not running there is always a risk for drifting snow and damp to penetrate into ducts. At some occasions also condensation can cause trouble.

H is manufactured as standard from galvanised steel sheet Z275, but is also available in aluminium zinc AZ 185, stainless steel sheet 1.4301, stainless acid-resistant steel sheet 1.4404 or painted.

H in dimensions 100 – 315 has a sleeve connection as standard and fits on the outside of ventilation ducts.

Dimensions 400 – 1250 are supplied with flange connection (including counter-flange) as standard. They are also supplied with twistable lifting and anchoring eyelets. An individual anchoring eyelet must not be subjected to forces in excess of 1 500 N.

All dimensions can also be obtained with connections that fit directly to the roof through connection TGR.

## Ordering example

Product	H	315	1
Dimension Ød			
Connection options			
Sleeve (standard 100 – 315)			1
Flange (standard 400 – 1250)			2
Transition piece to roof through connection			3–15

Specify size of roof through connection according to the measurement table to the right.

Specify separately if the hood is to be supplied with a pest-proof mesh from the factory.

Standard colours, see page 443.



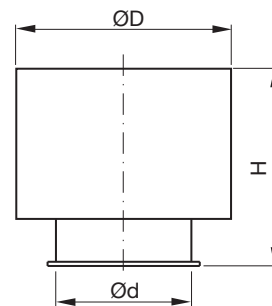





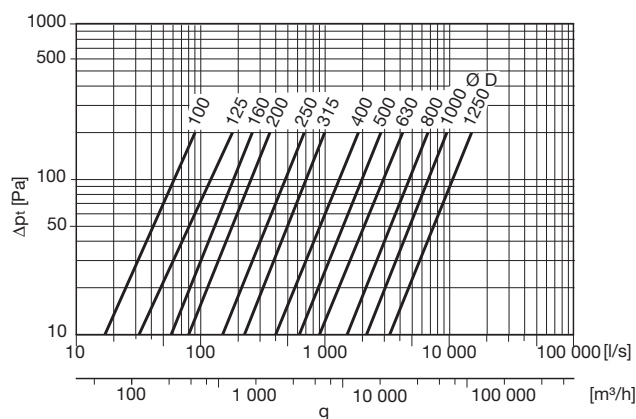





## Dimensions



Ød nom	ØD mm	H mm	Free area m <sup>2</sup>	m kg	Roof through connection TGR	
					50 mm	100 mm
					Size	
100	168	180	0,008	0,72	3	3
125	209	200	0,012	1,02	3	4
160	266	245	0,020	1,32	3	4
200	340	300	0,031	2,26	3	4
250	420	355	0,049	3,67	4	5
315	525	460	0,078	5,38	5	6
400	700	550	0,126	16,2	5	6
500	870	630	0,196	28,1	6	7
630	1115	780	0,312	40,9	8	9
800	1407	950	0,503	75,0	9	10
1000	1712	1180	0,785	108	11	12
1250	2092	1520	1,230	247	14	15

## Technical data



<b>Roof hood</b>	<b>H</b> 						
Roof transition connection piece, upper	<b>AGIS</b> 			<b>TGR-OA</b> 			
Roof transition	SR	SRI	SRIP	Sits around the roof transition			
				GISOL / GISOLP 	<b>TGR</b> 	<b>VHING / VHINP</b> 	Roof weather protection, outer
						<b>UG</b> 	Roof weather protection, inner
						<b>MG / MGL</b> 	Vapour membrane
Roof transition connection piece, lower					<b>TGR-NA</b> 		
Ducting	<b>SR</b> 			<b>LKR</b> 			

This diagram shows principally all possible combinations of how the products can be joined together. Normally only one alternative is chosen and sometimes some options are omitted.

For some combinations the needed size of a product isn't presented in the catalogue. In these cases the size needed most often can be produced and delivered to order.





## Description

Circular roof hood with angled upper side intended for outdoor air and extract air. The hood is designed for location above the roof with or without a roof through connection. The air runs both on the top- and downside of the hood. This is valid both for outdoor and extract air. The hood is free-draining downwards. Can also be supplied with a pest-proof mesh.

NOTE! When fans are not running there is always a risk for drifting snow and damp to penetrate into ducts. At some occasions also condensation can cause trouble. HV is manufactured as standard from galvanised steel plate Z275, but is also available in aluminium zinc AZ 185, stainless steel sheet 1.4301, stainless acid-resistant steel sheet 1.4404 or painted. HV is available with different angles in order to be in harmony with the architectural design of the building. HV in dimensions 100 – 315 has a sleeve connection as standard and fits on the outside of ventilation ducts. Dimensions 400 – 1250 are supplied with flange connection (including counter-flange) as standard. They are also supplied with twistable lifting and anchoring eyelets. An individual anchoring eyelet must not be subjected to forces in excess of 1 500 N.

All dimensions can also be obtained with connections that fit directly to the roof through connection TGR.

## Ordering example

	<b>HV</b>	<b>315</b>	<b>1</b>
Product			
Dimension Ød			
Connection options			
Sleeve (standard 100 – 315)		1	
Flange (standard 400 – 1250)		2	
Transition piece to roof through connection		3–15	

Specify size of roof through connection according to the measurement table to the right.

Specify separately if the hood is to be supplied with a pest-proof mesh from the factory and if a special angle is required. Standard colours, see page 443.

## Dimensions

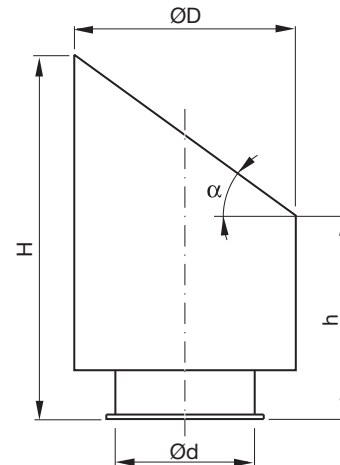





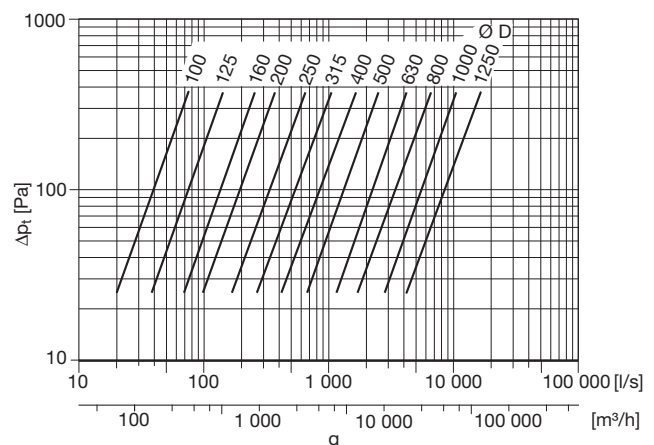





Ød nom	ØD mm	h mm	H mm	α °	Free area m <sup>2</sup>	m kg	Roof through connection TGR	
							50 mm Size	100 mm
100	168	180	343	45	0,008	0,79	3	3
125	209	200	403	45	0,012	1,12	3	4
160	266	245	479	42	0,020	1,45	3	4
200	340	300	567	39	0,031	2,47	3	4
250	420	355	664	37	0,049	4,03	4	5
315	525	460	834	36	0,078	5,91	5	6
400	700	550	1015	34	0,126	17,0	5	6
500	870	630	1188	33	0,196	29,4	6	7
630	1115	780	1470	32	0,312	43,0	8	9
800	1407	1040	1872	31	0,503	76,4	9	10
1000	1712	1270	2285	31	0,785	110	11	12
1250	2092	1585	2780	30	1,230	252	14	15

## Technical data





Roof hood	<p style="text-align: center;"><b>HV</b></p> 							
Roof transition connection piece, upper	<p style="text-align: center;"><b>AGIS</b></p> 			<p style="text-align: center;"><b>TGR-OA</b></p> 		Sits around the roof transition		
Roof transition	SR	SRI	SRIP	GISOL / GISOLP	TGR	VHING / VHINP	Roof weather protection, outer	
								UG
							MG / MGL	Vapour membrane
							SBG1	Roof transition fastener
Roof transition connection piece, lower					TGR-NA			
Ducting	<p style="text-align: center;">SR</p> 			<p style="text-align: center;">LKR</p> 				

This diagram shows principally all possible combinations of how the products can be joined together. Normally only one alternative is chosen and sometimes some options are omitted.

For some combinations the needed size of a product isn't presented in the catalogue. In these cases the size needed most often can be produced and delivered to order.



## Description

For air exit above roof.  
 Provided with a female connection which fits outside a ventilation duct.

## Dimensions

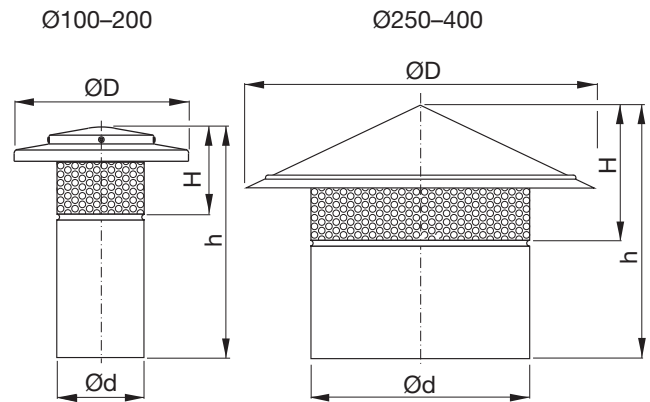





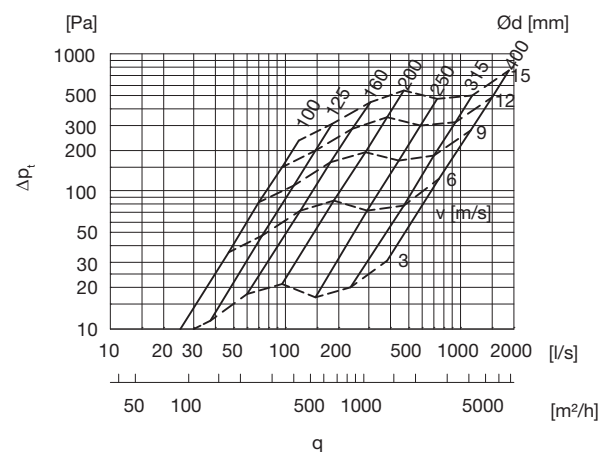









Ød nom	ØD mm	H mm	h mm	m kg	Roof through connection TGR	
					50 mm	100 mm
					Size	
100	200	99	264	0,51	3	3
125	225	102	267	0,65	3	4
160	260	105	270	0,81	3	4
200	315	114	273	1,09	3	4
250	400	156	291	1,45	4	5
315	500	185	303	1,99	5	6
400	600	226	344	2,70	5	6

## Technical data

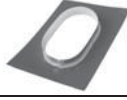

## Ordering example

Product **HU**  
 Dimension  $\text{Ød}$  **160**

Roof hood	<p style="text-align: center;"><b>HU</b></p> 						
Roof transition connection piece, upper	<p style="text-align: center;"><b>AGIS</b></p> 			<p style="text-align: center;"><b>TGR-OA</b></p> 		Sits around the roof transition	
Roof transition	SR	SRI	SRIP	<p style="text-align: center;"><b>GISOL / GISOLP</b></p> 	<p style="text-align: center;"><b>TGR</b></p> 	<p style="text-align: center;"><b>VHING / VHINP</b></p> 	Roof weather protection, outer
						<p style="text-align: center;"><b>UG</b></p> 	Roof weather protection, inner
						<p style="text-align: center;"><b>MG / MGL</b></p> 	Vapour membrane
						<p style="text-align: center;"><b>SBG1</b></p> 	Roof transition fastener
Roof transition connection piece, lower				<p style="text-align: center;"><b>TGR-NA</b></p> 			
Ducting	<p style="text-align: center;"><b>SR</b></p> 			<p style="text-align: center;"><b>LKR</b></p> 			

This diagram shows principally all possible combinations of how the products can be joined together. Normally only one alternative is chosen and sometimes some options are omitted.

For some combinations the needed size of a product isn't presented in the catalogue. In these cases the size needed most often can be produced and delivered to order.



## Dimensions

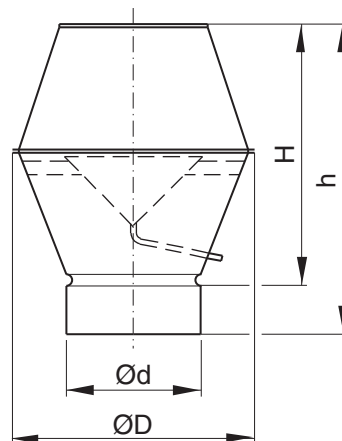

## Description

Ventilation hood for air exit above roof, suitable for both industrial and comfort ventilation. The air is ejected in an upwards-directed jet. This avoids contaminating the air in the vicinity of the hood, and soiling of the area around the hood. The ejection is so effective that you can install a fresh air inlet in the immediate vicinity of the hood, without any special precautions.

The hood is made of galvanised sheet steel, and can also be supplied in other materials such as stainless steel sheet 1.4301, stainless acid-resistant steel sheet 1.4404, aluzinc AZ185 and painted in various colours, to special order. It has a net over the opening and an internal rain funnel to collect rainwater and snow, which is drained out of the hood through a hose. The hose can withstand temperatures of between -45 and +65 °C.

The hood has a female connection, which fits outside a ventilation duct. The hood can be ordered with other connections, however.

As special delivery the hood can be supplied with three anchoring wire-loops.





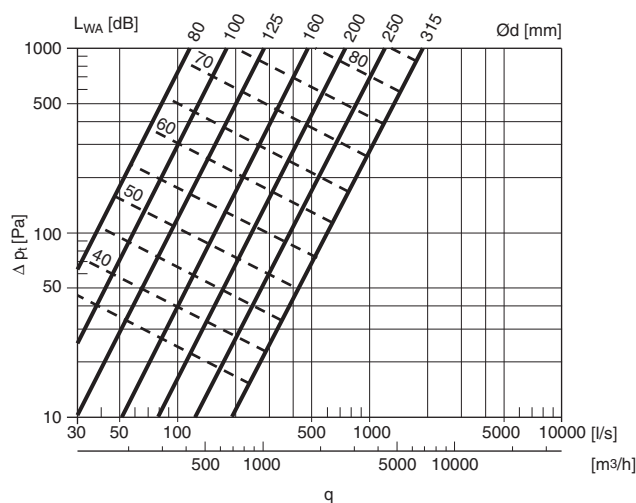



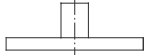

Ød nom	ØD mm	H mm	h mm	m kg	Roof through connection TGR	
					50 mm	100 mm
					Size	
80	130	160	310	0,66	3	3
100	180	220	360	0,96	3	3
125	225	240	380	1,26	3	4
160	280	340	475	1,95	3	4
200	345	420	555	2,92	3	4
250	430	505	640	4,31	4	5
315	550	620	755	6,75	5	6

## Technical data



## Ordering example

Product HN  
 Dimension Ød 315

<b>Roof hood</b>	<b>HN</b> 						
Roof transition connection piece, upper	<b>AGIS</b> 			<b>TGR-OA</b> 			
Roof transition	SR	SRI	SRIP	Sits around the roof transition			
				GISOL / GISOLP	TGR	VHING / VHINP	Roof weather protection, outer
						UG	Roof weather protection, inner
						MG / MGL	Vapour membrane
						SBG1	Roof transition fastener
Roof transition connection piece, lower				TGR-NA			
Ducting	<b>SR</b> 			<b>LKR</b> 			

This diagram shows principally all possible combinations of how the products can be joined together. Normally only one alternative is chosen and sometimes some options are omitted.

For some combinations the needed size of a product isn't presented in the catalogue. In these cases the size needed most often can be produced and delivered to order.

1
2
<b>3</b>
4
5
6
7
8
9
10
11
12
13
14
15
16
17
18



## Dimensions

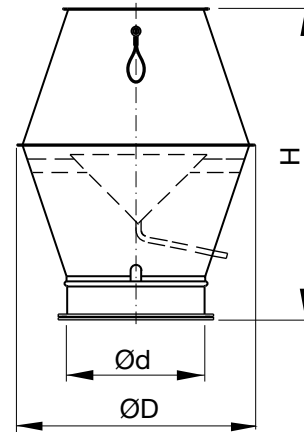

## Description

Ventilation hood for air exit above roof, suitable for both industrial and comfort ventilation. The air is ejected in an upwards-directed jet. This avoids contaminating the air in the vicinity of the hood, and soiling of the area around the hood. The ejection is so effective that you can install a fresh air inlet in the immediate vicinity of the hood, without any special precautions.

The hood is made of galvanised sheet steel, and can also be supplied in other materials such as stainless steel sheet 1.4301, stainless acid-resistant steel sheet 1.4404, aluzinc AZ185 and painted in various colours, to special order. It has a net over the opening and an internal rain funnel to collect rainwater and snow, which is drained out of the hood through a hose. The hose can withstand temperatures of between -45 and +65 °C.

The hood has a flange connection, which includes a mating flange. The hood can be ordered with other connections, however.

To avoid damage to the net in the opening the hood is supplied with transport protection. This must be removed before the hood is taken into service.

The hood is delivered with three turnable lifting and anchoring wire-loops. A single wire-loop shall not be exposed for forces exceeding 1500 N.

Ød nom	ØD mm	H mm	m kg	Roof through connection TGR	
				50 mm	100 mm
				Size	
400	685	905	11,1	5	6
500	855	1055	20,0	6	7
630	1075	1295	38,0	8	9
800	1360	1640	63,0	9	10
1000	1600	2110	89,1	11	12
1250	2020	2615	118	14	15

## Technical data

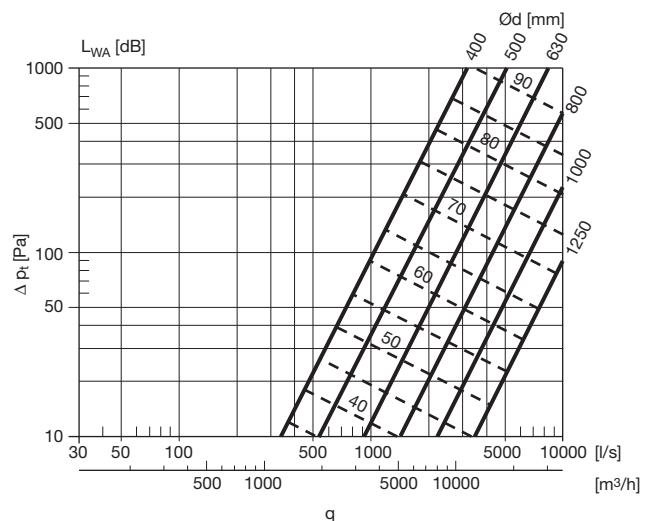

## Ordering example

Product **HF** **630**  
 Dimension  $\varnothing d$



## Description

The VHL lamella hood is developed specially to achieve an architectally correct ending of air intake and outlet on the roof.

The lamella hood is as standard delivered in galvanised design, can also be delivered in black powder coating.

In order to achieve a harmonic transition from duct to hood, the connection to the hood can be chosen either as a duct or as a roof transition (e.g. GISOL or GISOLP) with its dimensions corresponding to  $\varnothing D$ , below the roof the duct may be reduced to  $\varnothing d_1$  (see mounting proposal 1).

The lamella hood can well also be mounted directly on a duct with the diameter  $\varnothing d_1$  (see mounting proposal 2).

When connecting to the roof through connection TGR, the special transition piece TGR-VHL must be used (see page 469).

## Dimensions

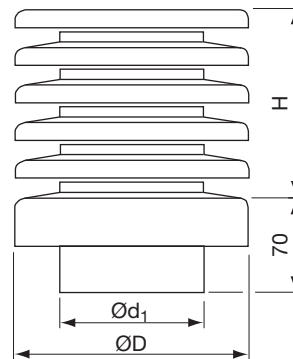

Ød nom	ØD mm	H mm	Free area m <sup>2</sup>	m kg	Outdoor air max. rec. * *m <sup>3</sup> /h	Roof through connection TGR	
						50 mm	100 mm
						Size	
100	224	110	0,019	1,40	175	3	3
125	250	145	0,033	1,90	270	3	4
160	280	180	0,055	2,30	430	3	4
200	315	250	0,100	3,40	690	3	4
250	400	250	0,125	5,20	1000	4	5
315	450	290	0,182	8,70	1600	5	6
400	560	370	0,306	13,4	2600	5	6
500	630	410	0,441	15,2	3900	6	7

\* Recommended maximum air flow when use of VHL as intake hood. H = building in measure.

### Alternative 1

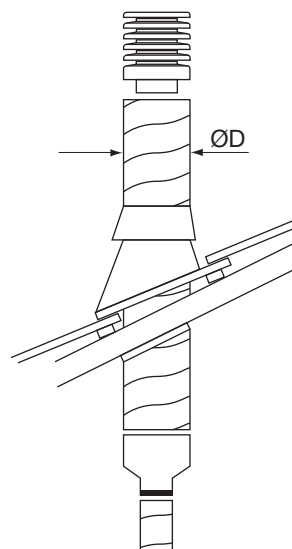

### Alternative 2

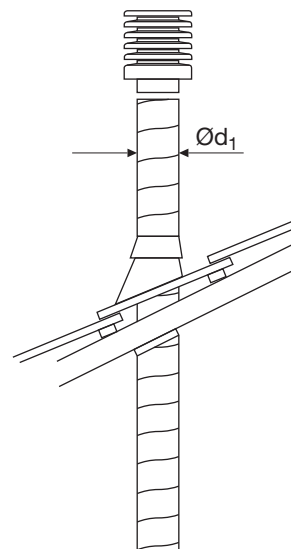

## Ordering example

Product	VHL	125	250	S
Dimension Ød				
Dimension ØD				
Colour, if desired				







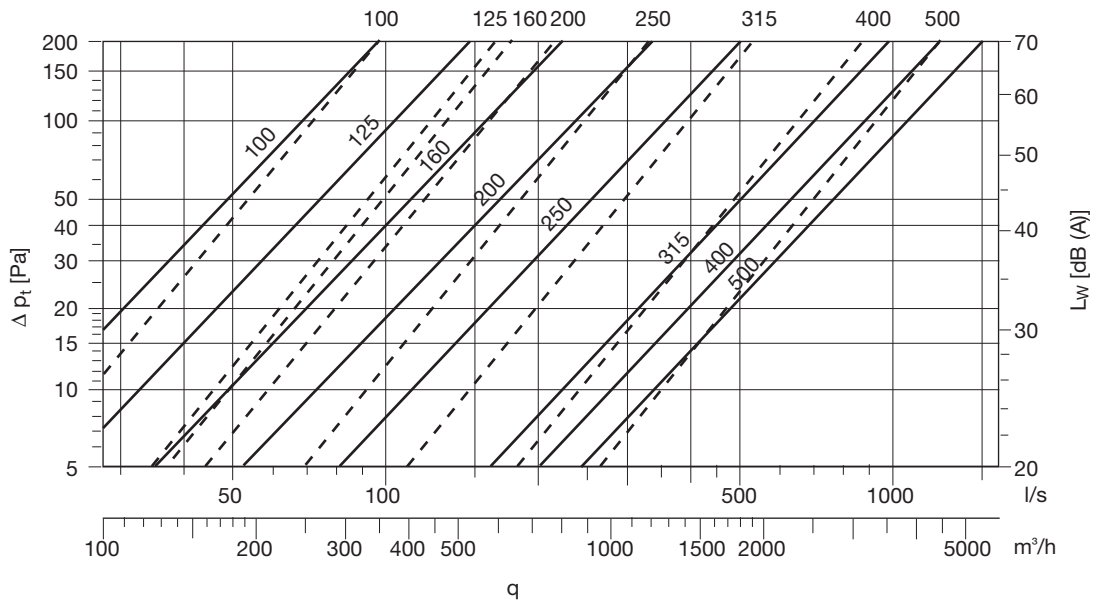



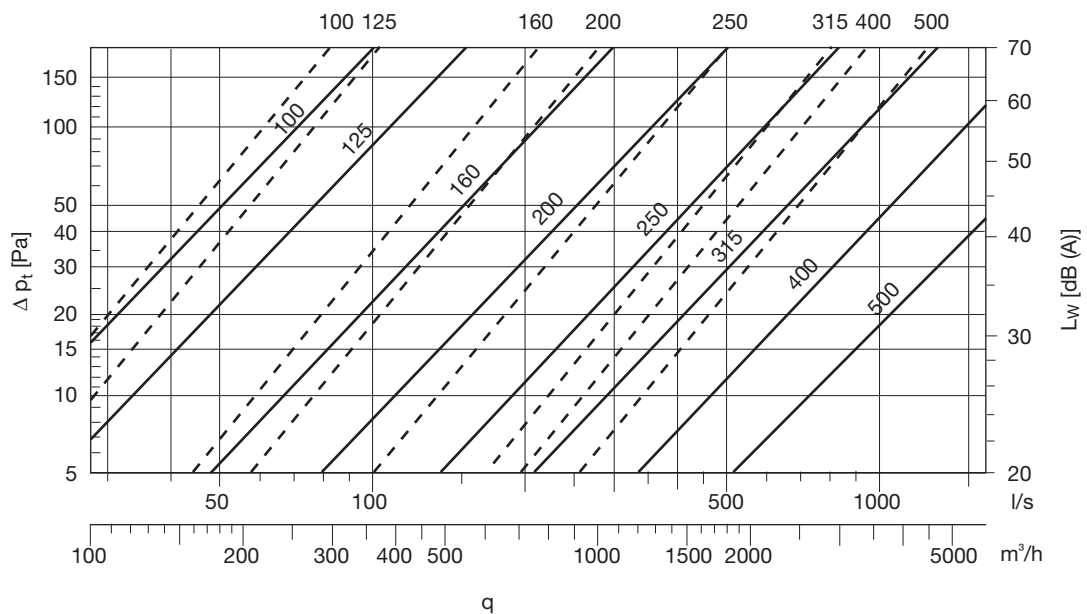

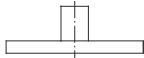

## Technical data

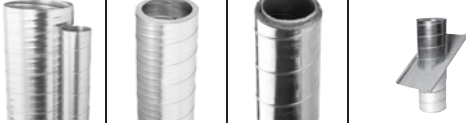
### Outdoor air



### Extract air



Roof hood	<b>VHL</b> 							
Roof transition connection piece, upper					<b>TGR-VHL</b> 	Sits around the roof transition		
Roof transition	SR	SRI	SRIP			<b>VHING / VHINP</b> 	Roof weather protection, outer	
					<b>TGR</b> 	<b>UG</b> 	Roof weather protection, inner	
							<b>MG / MGL</b> 	Vapour membrane
							<b>SBG1</b> 	Roof transition fastener
Roof transition connection piece, lower					<b>TGR-NA</b> 			
Ducting	<b>SR</b> 				<b>LKR</b> 			

This diagram shows principally all possible combinations of how the products can be joined together. Normally only one alternative is chosen and sometimes some options are omitted.

For some combinations the needed size of a product isn't presented in the catalogue. In these cases the size needed most often can be produced and delivered to order.

1
2
<b>3</b>
4
5
6
7
8
9
10
11
12
13
14
15
16
17
18



## Dimensions

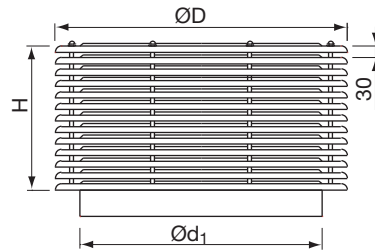

## Description

Circular lamella hood for air intake and outlet. The hood is as standard delivered in galvanized finish, but is also available with black powder coating or in acid-proof stainless material.

Ød <sub>1</sub> nom	ØD mm	H mm	Free area m <sup>2</sup>	m kg	Outdoor air max. rec. * m <sup>3</sup> /h
560	690	382	0,510	26,0	4400
630	760	444	0,770	33,0	5600
710	840	506	1,000	51,0	7100
800	930	537	1,210	55,0	9100
1000	1130	692	1,980	80,0	14000
1250	1380	810	2,950	90,0	21000

\* Recommended maximum air flow when use of VHL as intake hood. H= build measure.

## Ordering example

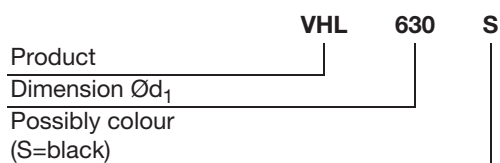



## Description

Rectangular roof hood intended for outdoor air and extract air. HRR is designed for positioning above the outer roof on the roof through connection.

The air runs both on the top- and downside of the hood. This is valid both for outdoor and extract air. The hood is free-draining downwards.

Can also be supplied with a pest-proof mesh.

HRR is manufactured as standard from galvanised steel sheet Z275, but is also available in aluminium zinc AZ 185, stainless steel sheet 1.4301, stainless acid-resistant steel sheet 1.4404 or painted.

Sizes 7 and 9 are supplied with four twistable lifting and anchoring wire-loops. An individual anchoring eyelet must not be subjected to forces in excess of 1 500 N.

## Ordering example

	<b>HRR</b>	<b>3</b>
Product		
Size		

Specify separately if the hood is to be supplied with a pest-proof mesh from the factory.  
Standard colours, see page 443.



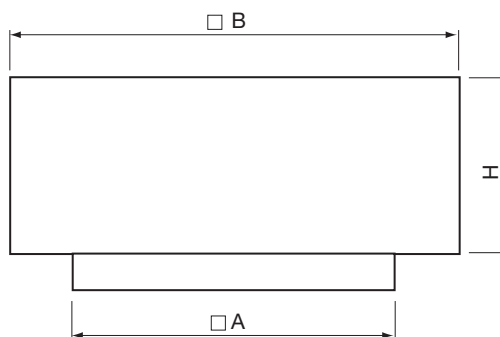



## Dimensions

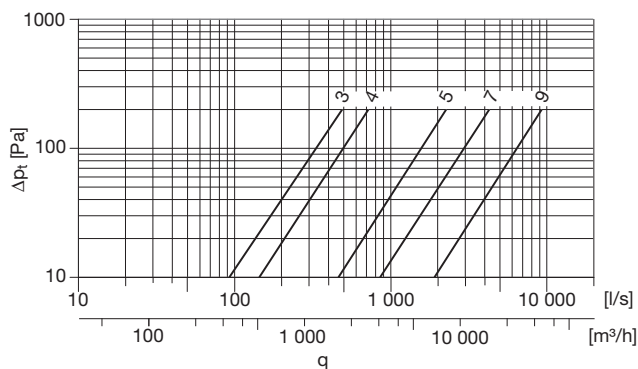

Size	A mm	B mm	H mm	Free area m <sup>2</sup>	m kg	Roof through connection TGR	
						50 mm Size	100 mm Size
3	400	450	150	0,045	5,00	3	3
4	500	550	205	0,100	7,80	4	4
5	600	750	300	0,260	11,9	5	5
7	800	1050	450	0,500	27,2	7	7
9	1000	1350	575	0,720	48,4	9	9

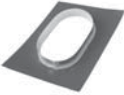
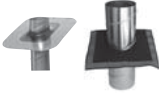
## Technical data



1	Roof hood	<b>HRR</b> 		Sits around the roof transition
2				
3	Roof transition	<b>TGR</b> 		<b>UG</b>  Roof weather protection, inner
4			<b>MG / MGL</b>  Vapour membrane	
5				
6	Roof transition connection piece, lower	<b>TGR-NA</b> 		
7	Ducting	<b>SR</b> 	<b>LKR</b> 	
8				
9				
10				
11				
12				
13				
14				
15				
16				
17				
18				

This diagram shows principally all possible combinations of how the products can be joined together. Normally only one alternative is chosen and sometimes some options are omitted.

For some combinations the needed size of a product isn't presented in the catalogue. In these cases the size needed most often can be produced and delivered to order.



## Description

Rectangular roof hood with angled upper side intended for outdoor air and extract air. HVR is designed for positioning above the outer roof on the roof through connection. The air runs both on the top- and downside of the hood. This is valid both for outdoor and extract air. The hood is free-draining downwards.

Can also be supplied with a pest-proof mesh.

HVR is manufactured as standard from galvanised steel sheet Z275, but is also available in aluminium zinc AZ 185, stainless steel sheet 1.4301, stainless acid-resistant steel sheet 1.4404 or painted.

HVR is available with different angles in order to be in harmony with the architectural design of the building.

Sizes 7 and 9 are supplied with four twistable lifting and anchoring wire-loops. An individual anchoring eyelet must not be subjected to forces in excess of 1 500 N.

## Ordering example

Product **HVR**  
Size **3**

Specify separately if the hood is to be supplied with a pest-proof mesh from the factory and if a special angle is required.

Standard colours, see page 443.

## Dimensions

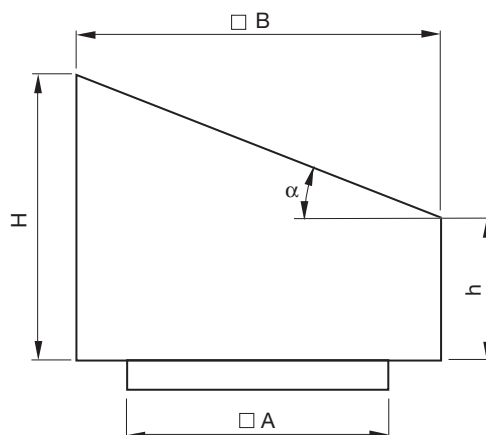



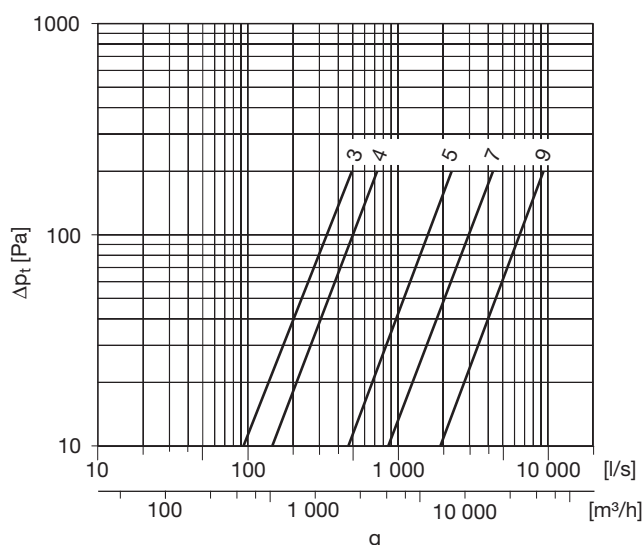

Size	A mm	B mm	h mm	H mm	$\alpha$ °	Free area m <sup>2</sup>	m kg	Roof through connec- tion TGR	
								50 mm Size	100 mm Size
3	400	450	150	410	30	0,045	6,40	3	3
4	500	550	205	525	30	0,100	9,90	4	4
5	600	750	300	735	30	0,260	17,0	5	5
7	800	1050	450	1060	30	0,500	34,3	7	7
9	1000	1350	575	1360	30	0,720	67,5	9	9

## Technical data

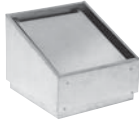

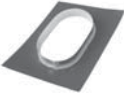
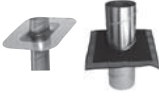
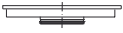
1  
2  
3  
4  
5  
6  
7  
8  
9  
10  
11  
12  
13  
14  
15  
16  
17  
18

Roof hood	<p style="text-align: center;"><b>HVR</b></p> 		Sits around the roof transition	
Roof transition	<p style="text-align: center;"><b>TGR</b></p> 		<p style="text-align: center;"><b>UG</b></p> 	Roof weather protection, inner
			<p style="text-align: center;"><b>MG / MGL</b></p> 	Vapour membrane
Roof transition connection piece, lower	<p style="text-align: center;"><b>TGR-NA</b></p> 			
Ducting	<p style="text-align: center;"><b>SR</b></p> 	<p style="text-align: center;"><b>LKR</b></p> 		

This diagram shows principally all possible combinations of how the products can be joined together. Normally only one alternative is chosen and sometimes some options are omitted.

For some combinations the needed size of a product isn't presented in the catalogue. In these cases the size needed most often can be produced and delivered to order.





## Dimensions

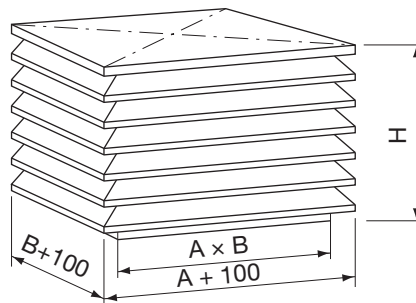

## Description

LHR is a rectangular roof hood with ribs that is used for both outdoor air and extract air.

When used for outdoor air intake it is recommended not to let the air velocity exceed 2 m/s due to risk of rain or snow pull in.

The hood is supplied as standard in galvanised form, but is also available painted.

LHR is supplied as standard with LS joint for guiding.

When connecting to the roof through connection TGR, the special transition piece TGR-LHR must be used. (see page 469).

When connecting to the roof through connection TGR, the special transition piece TGR-LHR must be used. (see page 469).

A mm	B mm	H mm	Num- ber of ribs	Free area m <sup>2</sup>	m kg	Roof through connection TGR	
						50 mm Size	100 mm Size
300	300	370	5	0,216	5,40	4	5
400	400	390	6	0,384	8,70	5	6
500	500	450	7	0,600	12,6	6	7
600	600	450	7	0,720	15,1	7	8
700	700	510	8	1,008	20,2	8	9
800	800	570	9	1,344	25,9	9	10
900	900	630	10	1,728	32,4	10	11
1000	1000	690	11	2,160	47,4	11	12
1100	1100	750	12	2,640	56,9	12	13
1200	1200	750	12	2,880	62,1	13	14
1300	1300	810	13	3,432	72,1	14	15
1400	1400	870	14	4,032	84,5	15	16
1500	1500	930	15	4,680	97,0	16	-

A x B = Duct dimensions

## Ordering example

	<b>LHR</b>	<b>S</b>	<b>300</b>	<b>300</b>	<b>1</b>	<b>LS</b>
Product						
Colour, if desired						
A in mm						
B in mm						
Duct connection						
Joining methods (Type 1)						

Standard colours, see page 443.





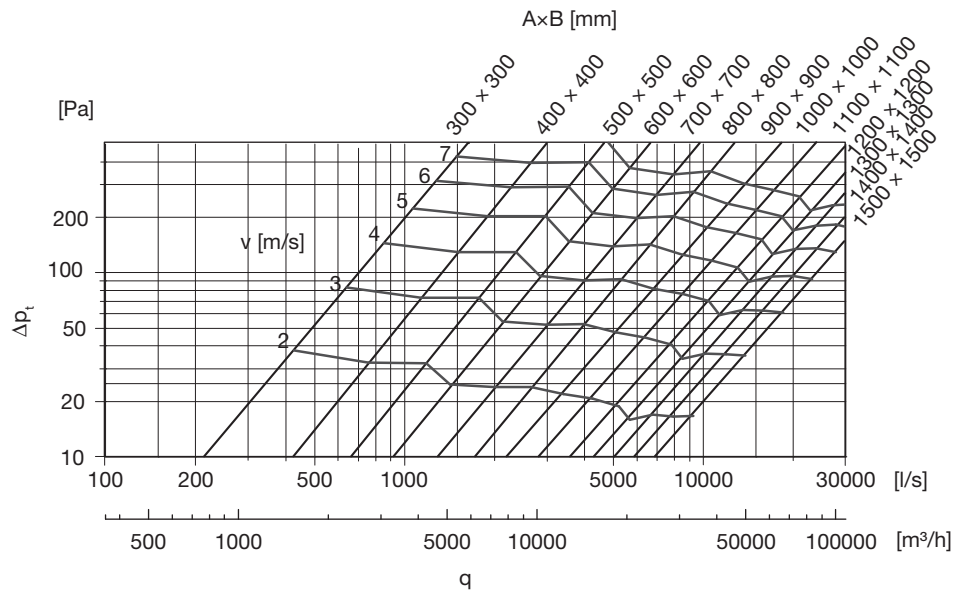



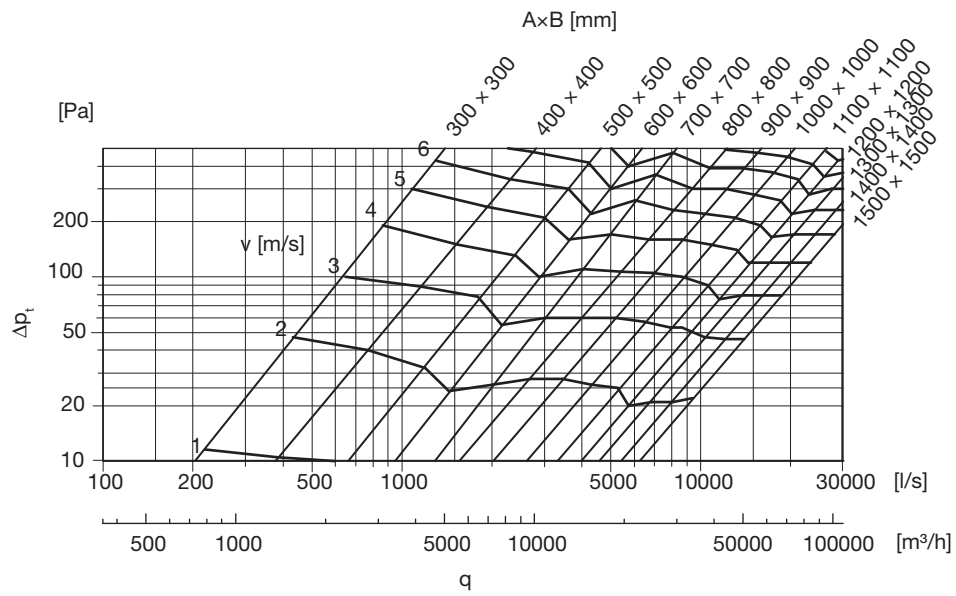

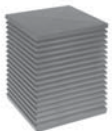
## Technical data

### Outdoor air

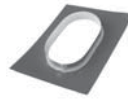

### Extract air



Roof hood	<b>LHR</b> 			
Roof transition connection piece, upper	<b>TGR-LHR</b> 			Sits around the roof transition
Roof transition	<b>TGFR</b> 	<b>TGR</b> 	<b>UG</b> 	Roof weather protection, inner
			<b>MG / MGL</b> 	Vapour membrane
			<b>SBGR</b> 	Roof transition fastener
Roof transition connection piece, lower			<b>TGR-NA</b> 	
Ducting	<b>LKR</b> 	<b>SR</b> 		

This diagram shows principally all possible combinations of how the products can be joined together. Normally only one alternative is chosen and sometimes some options are omitted.

For some combinations the needed size of a product isn't presented in the catalogue. In these cases the size needed most often can be produced and delivered to order.

1

2

3

4

5

6

7

8

9

10

11

12

13

14

15

16

17

18



## Dimensions

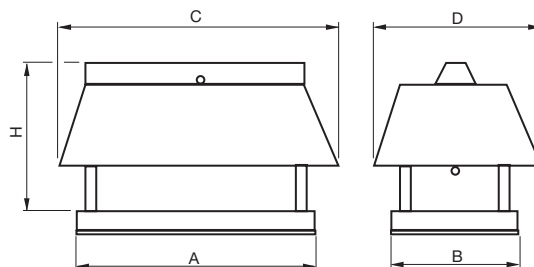

## Description

Combi-hood intended for outdoor air intake and the expelling of extract air.

HKOMR is designed for location above the roof with or without a roof through connection.

The intake and extract sections are separated with an internal wall. The intake section is protected against precipitation with a roof and pest-proof mesh. The extract section has a high-speed device and water-collection vessel. This part is also available with a pest-proof mesh. Air short circuit is prevented by the air intake's roof and the extract's high-speed device that ensures a long ejection distance.

HKOMR is manufactured as standard from galvanised steel sheet Z275, but is also available in aluminium zinc AZ 185, stainless steel sheet 1.4301, stainless acid-resistant steel sheet 1.4404 or painted.

HKOMR is produced as standard for installation on Lindab's roof through connection TGKOMR, but can also be supplied with a bottom part coupling designed to fit directly onto a duct.

## Ordering example

Product	HKOMR	2
Size		

Alternatives that should be specified separately if required:

- With pest-proof mesh on the extract section
- With a bottom part coupling designed to fit directly onto a duct.

Standard colours, see page 443.

Size	A mm	B mm	C mm	D mm	H mm
2	750	400	850	500	560
3	950	500	1050	600	590
4	1150	600	1450	900	640
5	1350	700	1650	1000	740
6	1550	800	1850	1100	840
8	1950	1000	2450	1500	910
10	2350	1200	2850	1700	1090
12	2750	1400	3350	2000	1170
14	3150	1600	3850	2300	1345

Size	Free area		m kg
	outdoor air m <sup>2</sup>	extract air m <sup>2</sup>	
2	0,138	0,030	16,7
3	0,202	0,059	23,1
4	0,291	0,098	36,6
5	0,501	0,162	50,3
6	0,764	0,256	65,9
8	1,159	0,420	102
10	1,948	0,624	148
12	2,639	1,055	244
14	3,180	1,331	320

## Technical data

### Expelling velocity extract air

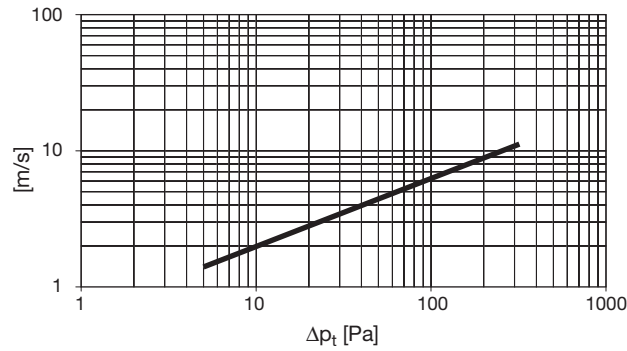

### Outdoor air

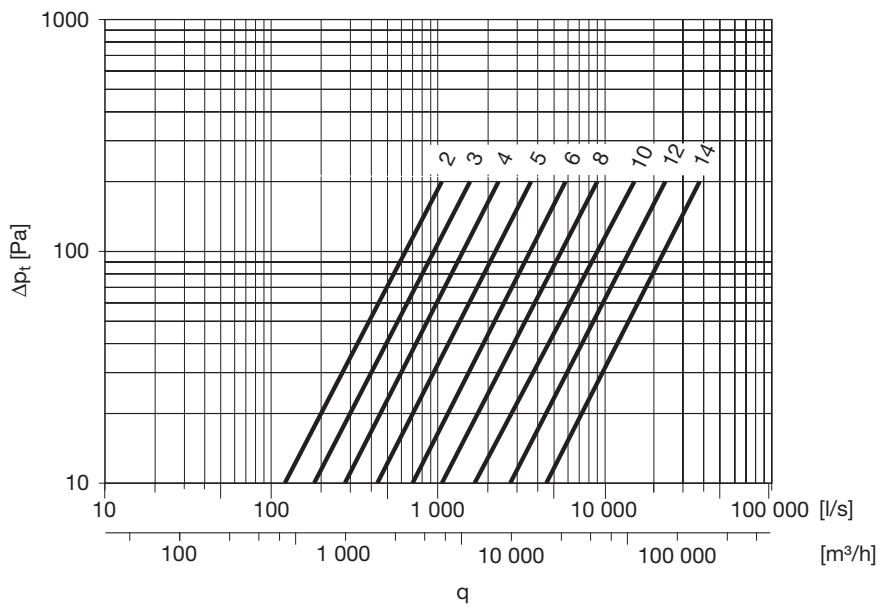



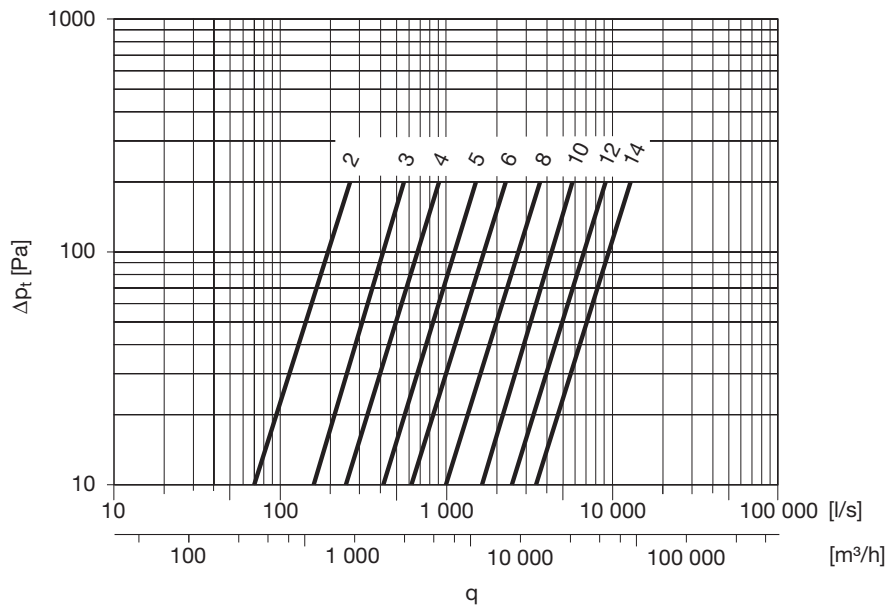



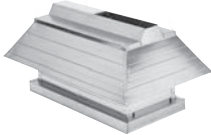

### Extract air



- 1
- 2
- 3
- 4
- 5
- 6
- 7
- 8
- 9
- 10
- 11
- 12
- 13
- 14
- 15
- 16
- 17
- 18

1  
2  
3  
4  
5  
6  
7  
8  
9  
10  
11  
12  
13  
14  
15  
16  
17  
18

Roof hood	<b>HKOMR</b> 			
Roof transition	<b>TGKOMR</b> 			
Roof transition connection piece, lower	<b>TGR-NA</b> 	<b>TGR-NA</b> 		
Ducting	<b>SR</b> 	<b>SR</b> 	<b>LKR</b> 	<b>LKR</b> 

This diagram shows principally all possible combinations of how the products can be joined together. Normally only one alternative is chosen and sometimes some options are omitted.

For some combinations the needed size of a product isn't presented in the catalogue. In these cases the size needed most often can be produced and delivered to order.



## Description

Intended for connection to roof hood and roof fan. Available with various types of insulation for condensation or fire protection. Two fixing profiles are supplied to suit the roof pitch.

The upper connection in sizes 100-315 suits roof hood HN, for example.

The upper connection in sizes 400-1200 is supplied without flange and is made so that you can use the enclosed mating flange from roof hood HF for instance.

TGR can as addition be provided with two through-connections for electric power and control voltage.

TGR is manufactured as standard from galvanized steel sheet Z275, but is also available in aluminium zinc AZ 185, stainless steel sheet 1.4301, stainless acid-resistant steel sheet 1.4404 or painted.

The duct connection is supplied with RJFP joint for guiding.

## Dimensions

### TGR-OA

– Upper connection

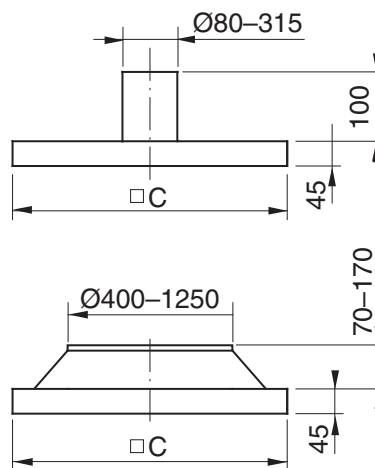

The C-measure of the upper connection (TGR-OA) shall fit the A-measure of the roof transition (TGR).

### TGR

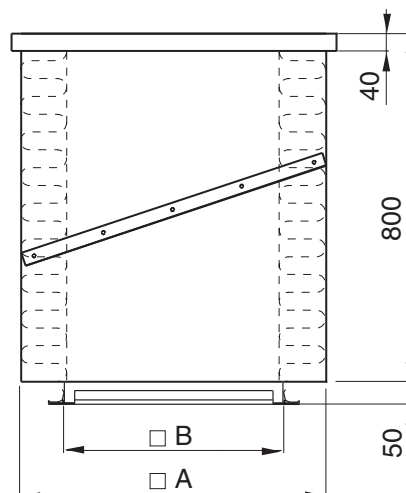

### TGR-NA

– Lower connection

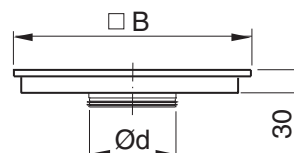



## Dimensions

Size	B mm			C mm	Weight kg	
	A mm	50 mm insul.	100 mm insul.		50 mm insul.	100 mm insul.
3	300	200	100	400	16,9	21,9
4	400	300	200	500	22,9	30,1
5	500	400	300	600	29,7	39,2
6	600	500	400	700	37,4	49,6
7	700	600	500	800	43,9	58,4
8	800	700	600	900	50,3	67,1
9	900	800	700	1000	59,2	78,8
10	1000	900	800	1100	65,9	87,9
11	1100	1000	900	1200	72,7	97,0
12	1200	1100	1000	1300	82,6	110,3
13	1300	1200	1100	1400	99,1	129,9
14	1400	1300	1200	1500	124,8	159,1
15	1500	1400	1300	1600	138,9	177,2
16	1600	1500	1400	1700	153,8	196,3

Hole punching dimensions (A + 20 mm) × (A + 20 mm)

## Ordering example

	TGR	3	1	2	1
Product					
Size					
Type of insulation					
Fire protection 50 mm		1			
Fire protection 100 mm		2			
Condensation 50 mm		3			
Internal cladding of insulation					
Zink plated steel		1			
Zink plated perf. steel		2			
Aluzink sheet metal AZ 185		3			
Aluzink sheet metal AZ185 perf.		4			
Stainl. acid-res. steel 1.4404		5			
Stainl. acid-res. steel perf. 1.4404		6			
No internal cladding (Only applicable at condensation insulation)		7			
Stainless steel 1.4301		8			
External material					
Zink plated steel		1			
Aluzink sheet metal AZ 185		2			
Stainl. acid-res. steel 1.4404		3			
Stainless steel 1.4301		4			

## Accessories

Upper connection	TGR-OA	3	125	1
Product				
Size				
Hood dimension				
Material				
Zink plated steel		1		
Aluzink sheet metal AZ 185		2		
Stainl. acid-res. steel 1.4404		3		
Stainless steel 1.4301		4		

















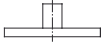

Lower connection	TGR-NA	3	125	1	50
Product					
Size					
Connection Measure					
Material					
Zink plated steel		1			
Aluzink sheet metal AZ 185		2			
Stainl. acid-res. steel 1.4401		3			
Stainless steel 1.4301		4			
Insulation thickness					

### Upper connection only for roof hood VHL

	TGR-VHL	-	3	-	125	-	1
Product							
Size							
Hood dimension							
Material							
Zink plated steel			1				
Aluzink sheet metal AZ 185			2				
Stainl. acid-res. steel 1.4404			3				
Stainless steel 1.4301			4				

### Upper connection only for roof hood LHR

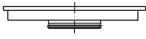
	TGR-LHR	-	5	-	400	-	400	-	1
Product									
Size									
A mm									
B mm									
Material									
Zink plated steel			1						
Aluzink sheet metal AZ 185			2						
Stainl. acid-res. steel 1.4404			3						
Stainless steel 1.4301			4						

	VH	HN	H	HU	VHA	VHP	HV	VHL	LHR	HVR	HRR		
Roof hood													
Roof transition connection piece, upper	TGR-OA 						TGR-VHL 	TGR-LHR 					Sits around the roof transition
Roof transition	<b>TGR</b> 										UG  Roof weather protection, inner	MG / MGL  Vapour membrane	
Roof transition connection piece, lower	TGR-NA 												
Ducting	SR 						LKR 						

This diagram shows principally all possible combinations of how the products can be joined together. Normally only one alternative is chosen and sometimes some options are omitted.

For some combinations the needed size of a product isn't presented in the catalogue. In these cases the size needed most often can be produced and delivered to order.

1
2
3
4
5
6
7
8
9
10
11
12
13
14
15
16
17
18



## Description

Roof transition adapted for combi-hood HKOMR. The transition is produced with 50 mm fire or condensation insulation. At connection to circular duct two lower connections TGR-NA are used. The roof transition is manufactured as standard in galvanised steel plate, but is available in stainless steel sheet 1.4301, stainless acid-resistant steel sheet 1.4404, aluminium zinc AZ 185 or painted. Two angle brackets are supplied for adaptation to the relevant roof incline. Sizes and dimensions according to drawing and table, but is available in extended version which is specified separately. The duct connections are supplied with RJFP joints for guiding.

## Ordering example

	<b>TGKOMR 3 1 2 1</b>
Product	
Size	
Type of insulation	
Fire protection 50 mm	1
Condensation 50 mm	2
Internal cladding of insulation	
Zink plated steel	1
Zink plated perf. steel	2
Aluzink sheet metal AZ 185	3
Aluzink sheet metal AZ185 perf.	4
Stainl. acid-res. steel 1.4404	5
Stainl. acid-res. steel perf. 1.4404	6
No internal cladding (Only applicable at condensation insulation)	7
Stainless steel 1.4301	8
External material	
Zink plated steel	1
Aluzink sheet metal AZ 185	2
Stainl. acid-res. steel 1.4404	3
Stainless steel 1.4301	4

Standard colours see page 443.

## Dimensions

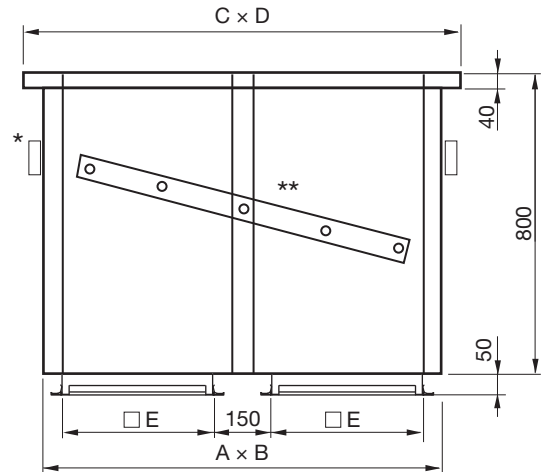

Size	A mm	B mm	C mm	D mm	E mm	m kg
2	650	300	740	390	200	32,5
3	850	400	940	490	300	43,5
4	1050	500	1140	590	400	54,3
5	1250	600	1340	690	500	72,4
6	1450	700	1540	790	600	84,5
8	1850	900	1940	990	800	113
10	2250	1100	2340	1190	1000	138
12	2650	1300	2740	1390	1200	190
14	3050	1500	3140	1590	1400	251

Hole punching dimensions =  $(A + 20) \times (B + 20)$

\* and \*\* are alternative positions for angle brackets





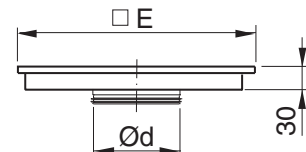



## TGKOMR-NA

– Lower connection



## Accessories

<b>Lower connection</b>	<b>TGKOMR-NA 3 125 1</b>
Product	
Size	
Connection measure	
Material	
Zink plated steel	1
Aluzink sheet metal AZ 185	2
Stainl. acid-res. steel 1.4404	3
Stainless steel 1.4301	4

Roof hood	<b>HKOMR</b> 			
<b>Roof transition</b>	<b>TGKOMR</b> 			
Roof transition connection piece, lower	<b>TGKOMR-NA</b> 	<b>TGKOMR-NA</b> 		
Ducting	<b>SR</b> 	<b>SR</b> 	<b>LKR</b> 	<b>LKR</b> 

This diagram shows principally all possible combinations of how the products can be joined together. Normally only one alternative is chosen and sometimes some options are omitted.

For some combinations the needed size of a product isn't presented in the catalogue. In these cases the size needed most often can be produced and delivered to order.

1
2
<b>3</b>
4
5
6
7
8
9
10
11
12
13
14
15
16
17
18

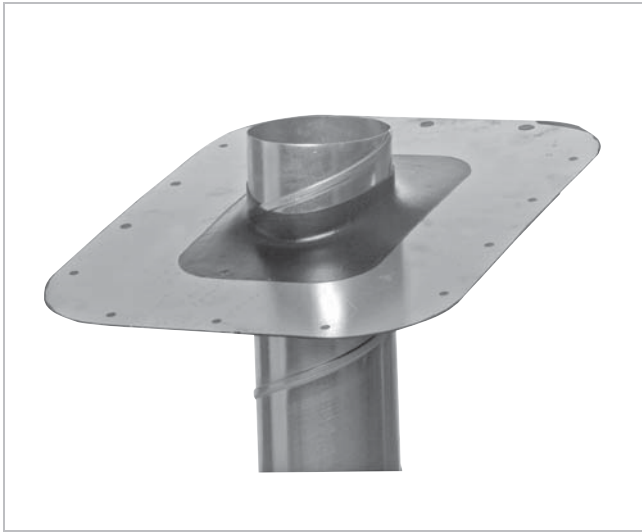

## Description

The product is based on a special flexible 2-component rubber (1) that is integrated with a 1 mm aluminium plate (2).

Used for sealing of the building envelope for all types of pipes and ducts, which is lead trough a vapour barrier of roofing underlay.

The product can be used as a roofing underlay transition or as a vapour barrier sheet, in the ridge as well as on the inclined roof area.

You will also find screwholes (3) ready for fixed roofing underlay, concrete floor or floor structures.

A special mounting instruction exists for this product.

## Mounting

The membrane is easy to adjust; cut a hole that is 20 mm smaller than the duct dimension. The product can be used on roof pitches from 0-55° without any special precautions. The transition can be used in the ridge by bending it at the centre and adjusting it to the actual roof slope.

The product can be assembled with the roofing underlay by means of double coated tape and/or perform adhesive. You will also find screw holes (3) ready for fixed roofing underlay, concrete floor or floor structures.

## Ordering example

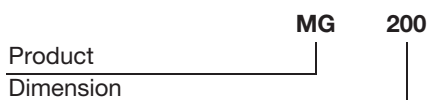

## Dimensions

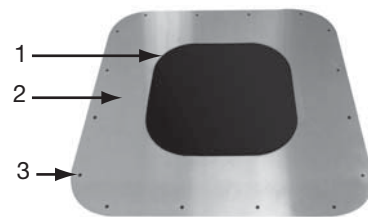
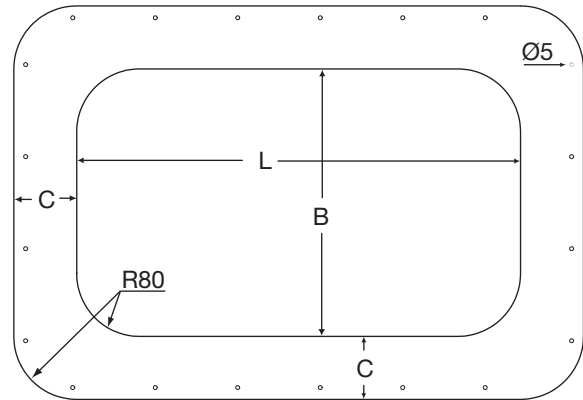

**Special transition designet for ceiling, shaft etc. used for ducts from Ø100 - Ø160**

Type	Max. duct measure □ / Ø mm	B x L x C mm	m kg
MG 1016	160	200 x 200 x 50	0,32

## Standard transition

Type	Max. duct measure □ / Ø mm	B x L x C mm	m kg
MG 100	110	150 x 230 x 80	0,40
MG 200	200	240 x 390 x 80	0,78
MG 315	315	340 x 565 x 80	1,36
MG 400	405	445 x 750 x 80	1,76
MG 450	450	490 x 790 x 80	1,80
MG 560	560	620 x 1000 x 80	1,90
MG 710	710	750 x 1280 x 80	2,00

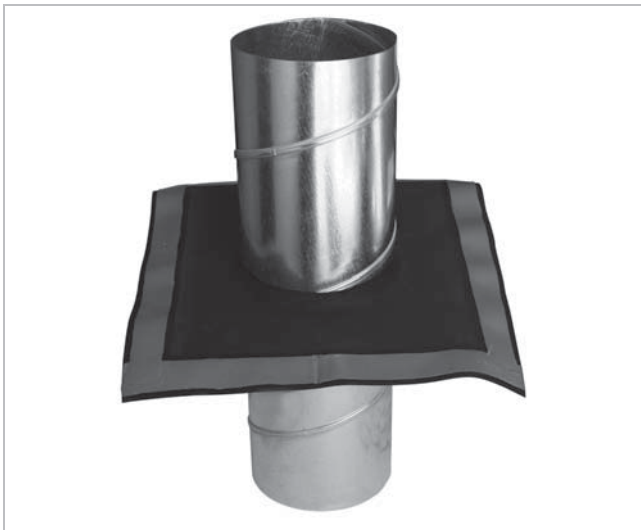

## Description

Made from a special flexible syntetic rubber and provided with tape with adhesive on both sides.

Is used for sealing of the climate shield to all sorts of pipes and ducts, which passes through moisture barrier or roofing underlay.

A special mounting instruction exists for this product.

## Dimensions

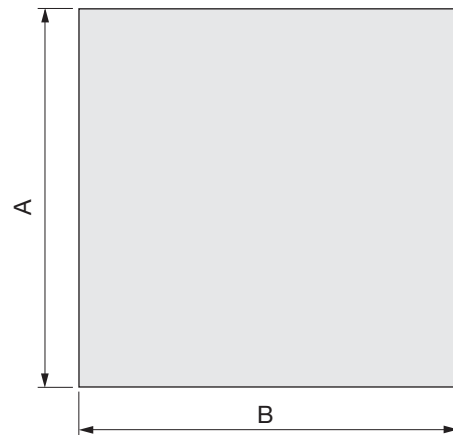

Type	Max. duct dimension □ / Ø mm	A × B mm	m kg
MGL 80	80	200 × 200	0,10
MGL 125	125	250 × 250	0,10
MGL 160	160	300 × 300	0,15
MGL 250	250	400 × 400	0,20
MGL 355	355	500 × 500	0,25

## Ordering example

Product	MGL	160
Dimension		

- 1
- 2
- 3
- 4
- 5
- 6
- 7
- 8
- 9
- 10
- 11
- 12
- 13
- 14
- 15
- 16
- 17
- 18