

# **13. WALL MOUNTED TYPE PACKAGED AIR-CONDITIONER ( Split system, Air cooled ) cooling only type**

**Alternative refrigerant R407C use models**

**FDKNP208CEN-S  
258CEN-S  
308CEN-S  
308CES-S**

## CONTENTS

<b>13.1</b>	<b>GENERAL INFORMATION</b> .....	<b>505</b>
13.1.1	Specific features .....	505
13.1.2	How to read the model name .....	505
<b>13.2</b>	<b>SELECTION DATA</b> .....	<b>506</b>
13.2.1	Specifications .....	506
13.2.2	Range of usage & limitations .....	510
13.2.3	Exterior dimensions .....	511
13.2.4	Exterior appearance .....	517
13.2.5	Piping system .....	518
13.2.6	Selection chart .....	520
13.2.7	Noise level .....	522
<b>13.3</b>	<b>ELECTRICAL DATA</b> .....	<b>523</b>
13.3.1	Electrical wiring .....	523
<b>13.4</b>	<b>OUTLINE OF OPERATION CONTROL BY MICROCOMPUTER</b> .....	<b>526</b>
<b>13.5</b>	<b>APPLICATION DATA</b> .....	<b>526</b>
<b>13.6</b>	<b>MAINTENANCE DATA</b> .....	<b>526</b>

## 13.1 GENERAL INFORMATION

### 13.1.1 Specific features

- (1) Less refrigerant charge amount due to use of double phase refrigerant flow system. The total refrigerant charge amount has been reduced by more than 50%.
- (2) The indoor outdoor interconnection signal wiring has been done away with. The microcomputer chip is installed in the indoor unit. There is no need for the unit to communicate between the outdoor and indoor units so the unit is more resistant to electromagnetic noise thus the incidence of microcomputer malfunction has been reduced. The compressor in the outdoor unit has its own self protection function, that reacts according to abnormal high pressure and excessive high temperature.
- (3) There are only four power line between the outdoor and indoor unit. As no signal wire is used there is no need to separate the power line from the signal line. One cab tyre cable with 4 wires encased in one sheath is enough for conducting the wiring work between the outdoor unit and the indoor unit. This contributes to simpler wiring work in the field.
- (4) The operation modes are only cooling and fan operation for easier control.
- (5) All air supply ports have auto swing louvers. The indoor fan motor has two speeds of high and low.
- (6) The controls are wireless residential split air conditioner type remote controller with 4 malfunction modes.
- (7) All models have service valves protruding from the outdoor unit for faster flare connection work in the field.

#### (8) Aero trap louver

- (a) Pleasantness will be enhanced with the employment of aero trap louver. It has an excellent wind orientation and a homogeneous air conditioning feeling is ensured at every corner in a room with the auto swing blasting which can be adjusted the maximum 70° downward.
- (b) Louver angle can be adjusted to 4 fixed positions with the remote control. It can be adjusted at any optional angle during the manual operation. Sidewise blast is adjustable by 40° in each direction.

#### (9) Low noise

Specially developed silent fan is employed. A very gentle operation sound is assured because the noise like wind slashing sound are suppressed effectively.

#### (10) Thin and compact design

The unit measures 17.9 cm (208 type) or 19.6 cm (258, 308 type) in thickness and its size is so compact as a room air conditioner. Body of the unit is finished in the ivory white color and a pleasant and simple design produces a very pleasant harmony for the interior design.

### 13.1.2 How to read the model name

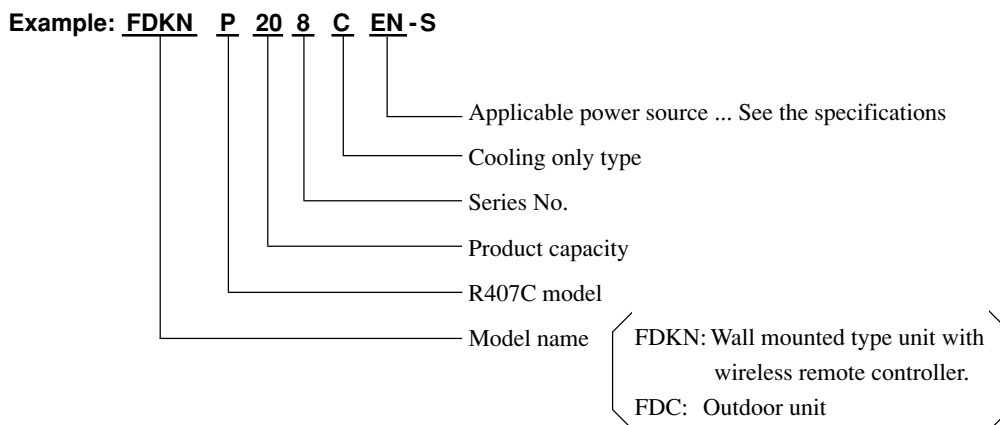

# 13.2 SELECTION DATA

## 13.2.1 Specifications

Model FDKNP208CEN-S

Item		Model	FDKNP208CEN-S	
			FDKN208C	FDCP208CEN3
<b>Nominal cooling capacity<sup>(1)</sup></b>		W	4850	
<b>Power source</b>			1 Phase, 220/240V, 50Hz	
Operation data <sup>(3)</sup>	Cooling input	kW	2.03/2.09	
	Running current (Cooling)	A	9.4/9.5	
	Power factor (Cooling)	%	98/92	
	Inrush current (L.R.A)	A	55	
	Noise level <sup>(4)</sup>	dB(A)	Hi:45 Lo:38	52
<b>Exterior dimensions</b>				
<b>Height × Width × Depth</b>		mm	275 × 790 × 179	690 × 880 × 290
<b>Net weight</b>		kg	10	49
<b>Refrigerant equipment</b>				
<b>Compressor type &amp; Q'ty</b>			–	RM5523HNE5 × 1
Motor		kW	–	1.7
Starting method			–	Line starting
<b>Heat exchanger</b>			Louver fins & inner grooved tubing	Slitted fins & bare tubing
Refrigerant control			–	Capillary tube
<b>Refrigerant</b>			R407C	
<b>Quantity</b>		kg	<b>Holding charged</b>	0.87 [Pre-charged up to the piping length of 5m]
<b>Refrigerant oil</b>		ℓ	–	0.7 (MA32)
High pressure control			–	
<b>Air handling equipment</b>				
Fan type & Q'ty			Tangential fan × 1	Propeller fan × 1
Motor		W	26 × 1	55 × 1
Starting method			Line starting	Line starting
<b>Air flow (Standard)</b>		CMM	<b>Hi:16 Lo:10</b>	<b>55</b>
<b>Fresh air intake</b>			Unavailable	–
Air filter, Q'ty			Long life filter × 2 (washable)	–
Shock & vibration absorber			Rubber sleeve (for fan motor)	Rubber mount (for compressor)
Electric heater		W	–	20 (Crank case heater)
<b>Operation control</b>				
Operation switch			Wireless remote control switch	– (Indoor unit side)
Room temperature control			Thermostat by electronics	–
<b>Safety equipment</b>			Internal thermostat for fan motor. Frost protection thermostat.	Internal thermostat for fan motor. Thermistor for discharge temperature. High pressure switch for protection.
<b>Installation data</b>				
<b>Refrigerant piping size</b>		mm (in)	Liquid line: φ6.35 (1/4") Gas line: φ15.88 (5/8")	
<b>Connecting method</b>			Flare piping	
<b>Drain hose</b>			(Connectable with VP20)	–
Insulation for piping			Necessary (both Liquid & Gas lines)	
Accessories			Mounting kit. Wireless remote controller.	
Optional parts			–	

Notes (1) The data are measured at the following conditions.

Operation	Item	Indoor air temperature		Outdoor air temperature		Standards
		DB	WB	DB	WB	
Cooling		27°C	19°C	35°C	24°C	ISO-T1, JIS B8616

(2) This packaged air-conditioner is manufactured and tested in conformity with the following standard.

JIS B8616 "UNITARY AIR-CONDITIONERS"

(3) The operation data indicate when the air-conditioner is operated at 220/240V 50Hz.

(4) Indicates the value at mild mode.

**Model FDKNP258CEN-S**

Item		Model	FDKNP258CEN-S	
			FDKN258C	FDCP258CEN3
<b>Nominal cooling capacity<sup>(1)</sup></b>		W	5700	
<b>Power source</b>			1 Phase, 220/240V, 50Hz	
<b>Operation data<sup>(3)</sup></b>	Cooling input	kW	2.34/2.53	
	Running current (Cooling)	A	11.2/12.3	
	Power factor (Cooling)	%	95/86	
	Inrush current (L.R.A)	A	63	
	Noise level <sup>(4)</sup>	dB(A)	Hi:45 Lo:38	52
<b>Exterior dimensions</b>				
<b>Height × Width × Depth</b>		mm	298 × 940 × 196	845 × 880 × 340
<b>Net weight</b>		kg	11	55
<b>Refrigerant equipment</b>				
<b>Compressor type &amp; Q'ty</b>			–	RM5526HNE5 × 1
Motor		kW	–	1.9
Starting method			–	Line starting
<b>Heat exchanger</b>			Louver fins & inner grooved tubing	Slitted fins & bare tubing
Refrigerant control			–	Capillary tube
<b>Refrigerant</b>			R407C	
<b>Quantity</b>		kg	<b>Holding charged</b>	1.07 [Pre-charged up to the piping length of 5m]
<b>Refrigerant oil</b>		ℓ	–	0.7 (MA32)
High pressure control			–	
<b>Air handling equipment</b>				
Fan type & Q'ty			Tangential fan × 1	Propeller fan × 1
Motor		W	40 × 1	55 × 1
Starting method			Line starting	Line starting
<b>Air flow (Standard)</b>		CMM	Hi:17 Lo:10	58
<b>Fresh air intake</b>			Unavailable	–
Air filter, Q'ty			Long life filter × 2 (washable)	–
Shock & vibration absorber			Rubber sleeve (for fan motor)	Rubber mount (for compressor)
Electric heater		W	–	20 (Crank case heater)
<b>Operation control</b>				
Operation switch			Wireless remote control switch	– (Indoor unit side)
Room temperature control			Thermostat by electronics	–
<b>Safety equipment<sup>(4)</sup></b>			Internal thermostat for fan motor. Frost protection thermostat.	Internal thermostat for fan motor. Thermistor for discharge temperature. High pressure switch for protection.
<b>Installation data</b>		mm	Liquid line: φ9.52 (3/8") Gas line: φ15.88 (5/8")	
<b>Refrigerant piping size</b>		(in)		
<b>Connecting method</b>			Flare piping	
<b>Drain hose</b>			(Connectable with VP16)	–
Insulation for piping			Necessary (both Liquid & Gas lines)	
Accessories			Mounting kit. Wireless remote controller. Drain hose	
Optional parts			–	

Notes (1) The data are measured at the following conditions.

Operation	Item	Indoor air temperature		Outdoor air temperature		Standards
		DB	WB	DB	WB	
Cooling		27°C	19°C	35°C	24°C	ISO-T1, JIS B8616

- (2) This packaged air-conditioner is manufactured and tested in conformity with the following standard.  
JIS B8616 "UNITARY AIR-CONDITIONERS"
- (3) The operation data indicate when the air-conditioner is operated at 220/240V 50Hz.
- (4) Indicates the value at mild mode.

## Model FDKNP308CEN-S

Item		Model	FDKNP308CEN-S	
			FDKN308C	FDCP308CEN3
<b>Nominal cooling capacity<sup>(1)</sup></b>		W	7100	
<b>Power source</b>			1 Phase, 220/240V, 50Hz	
<b>Operation data<sup>(3)</sup></b>	Cooling input	kW	3.18/3.33	
	Running current (Cooling)	A	14.8/15.2	
	Power factor (Cooling)	%	98/91	
	Inrush current (L.R.A)	A	95	
	Noise level <sup>(4)</sup>	dB(A)	Hi:46 Lo:40	52
<b>Exterior dimensions</b>				
<b>Height × Width × Depth</b>		mm	298 × 1155 × 196	845 × 880 × 340
<b>Net weight</b>		kg	11	73
<b>Refrigerant equipment</b>				
<b>Compressor type &amp; Q'ty</b>			–	GT-A5534HN41 × 1
Motor		kW	–	2.5
Starting method			–	Line starting
<b>Heat exchanger</b>			Louver fins & inner grooved tubing	Slitted fins & bare tubing
Refrigerant control			–	Capillary tube
<b>Refrigerant</b>			R407C	
<b>Quantity</b>		kg	<b>Holding charged</b>	1.63 [Pre-charged up to the piping length of 5m]
<b>Refrigerant oil</b>		ℓ	–	1.45 (MA32)
High pressure control			–	–
<b>Air handling equipment</b>				
Fan type & Q'ty			Tangential fan × 1	Propeller fan × 1
Motor		W	40 × 1	55 × 1
Starting method			Line starting	Line starting
<b>Air flow (Standard)</b>		CMM	<b>Hi:21 Lo:15</b>	<b>58</b>
<b>Fresh air intake</b>			Unavailable	–
Air filter, Q'ty			Long life filter × 2 (washable)	–
Shock & vibration absorber			Rubber sleeve (for fan motor)	Rubber mount (for compressor)
Electric heater		W	–	33 (Crank case heater)
<b>Operation control</b>				
Operation switch			Wireless remote control switch	– (Indoor unit side)
Room temperature control			Thermostat by electronics	–
<b>Safety equipment</b>				
			Internal thermostat for fan motor. Frost protection thermostat.	Internal thermostat for fan motor. Thermistor for discharge temperature. High pressure switch for protection.
<b>Installation data</b>		mm	<b>Liquid line: φ9.52 (3/8") Gas line: φ15.88 (5/8")</b>	
<b>Refrigerant piping size</b>		(in)		
<b>Connecting method</b>			<b>Flare piping</b>	
<b>Drain hose</b>			(Connectable with VP16)	–
Insulation for piping			Necessary (both Liquid & Gas lines)	
Accessories			Mounting kit. Wireless remote controller. Drain hose	
Optional parts			–	

Notes (1) The data are measured at the following conditions.

Operation	Item	Indoor air temperature		Outdoor air temperature		Standards
		DB	WB	DB	WB	
Cooling		27°C	19°C	35°C	24°C	ISO-T1, JIS B8616

(2) This packaged air-conditioner is manufactured and tested in conformity with the following standard.

JIS B8616 "UNITARY AIR-CONDITIONERS"

(3) The operation data indicate when the air-conditioner is operated at 220/240V 50Hz.

(4) Indicates the value at mild mode.

**Model FDKNP308CES-S**

Item	Model	FDKNP308CES-S	
		FDKN308C	FDCP308CES3
<b>Nominal cooling capacity<sup>(1)</sup></b>	W	<b>7100</b>	
<b>Power source</b>		<b>3 Phase, 380/415V, 50Hz</b>	
<b>Operation data<sup>(3)</sup></b>	Cooling input	kW	3.10/3.25
	Running current (Cooling)	A	5.4/5.7
	Power factor (Cooling)	%	87/79
	Inrush current (L.R.A)	A	43
	Noise level <sup>(4)</sup>	dB(A)	Hi:46 Lo:40
<b>Exterior dimensions</b>			
<b>Height × Width × Depth</b>	mm	<b>298 × 1150 × 196</b>	<b>845 × 880 × 340</b>
<b>Net weight</b>	kg	<b>13.5</b>	<b>73</b>
<b>Refrigerant equipment</b>			
<b>Compressor type &amp; Q'ty</b>		–	<b>GT-A5534HS41 × 1</b>
Motor	kW	–	<b>2.5</b>
Starting method		–	Line starting
<b>Heat exchanger</b>		Louver fins & inner grooved tubing	Slitted fins & bare tubing
Refrigerant control		–	Capillary tube
<b>Refrigerant</b>		<b>R407C</b>	
<b>Quantity</b>	kg	<b> Holding charged</b>	<b>1.63 [Pre-charged up to the piping length of 5m]</b>
<b>Refrigerant oil</b>	ℓ	–	<b>1.45 (MA32)</b>
High pressure control			–
<b>Air handling equipment</b>			
Fan type & Q'ty		Tangential fan × 1	Propeller fan × 1
Motor	W	<b>40 × 1</b>	<b>55 × 1</b>
Starting method		Line starting	Line starting
<b>Air flow (Standard)</b>	<b>CMM</b>	<b>Hi:21 Lo:15</b>	<b>58</b>
<b>Fresh air intake</b>		Unavailable	–
Air filter, Q'ty		Long life filter × 2 (washable)	–
Shock & vibration absorber		Rubber sleeve (for fan motor)	Rubber mount (for compressor)
Electric heater	W	–	33 (Crank case heater)
<b>Operation control</b>			
Operation switch		Wireless remote control switch	– (Indoor unit side)
Room temperature control		Thermostat by electronics	–
<b>Safety equipment</b>			
		Internal thermostat for fan motor. Frost protection thermostat.	Internal thermostat for fan motor. Thermistor for discharge temperature. High pressure switch for protection.
<b>Installation data</b>			
<b>Refrigerant piping size</b>	mm (in)	<b>Liquid line: φ9.52 (3/8") Gas line: φ15.88 (5/8")</b>	
<b>Connecting method</b>		<b>Flare piping</b>	
<b>Drain hose</b>		(Connectable with VP16)	–
Insulation for piping		Necessary (both Liquid & Gas lines)	
Accessories		Mounting kit. Wireless remote controller. Drain hose	
Optional parts		–	

Notes (1) The data are measured at the following conditions.

Operation	Item	Indoor air temperature		Outdoor air temperature		Standards
		DB	WB	DB	WB	
Cooling		27°C	19°C	35°C	24°C	ISO-T1, JIS B8616

- (2) This packaged air-conditioner is manufactured and tested in conformity with the following standard.  
JIS B8616 "UNITARY AIR-CONDITIONERS"
- (3) The operation data indicate when the air-conditioner is operated at 380/415V 50Hz.
- (4) Indicates the value at mild mode.

### 13.2.2 Range of usage & limitations

Models	FDKNP208, 258 type	FDKNP308 type
Item		
Indoor return air temperature (Upper, lower limits)	Refer to the selection chart	
Outdoor air temperature (Upper, lower limits)		
Refrigerant line (one way) length	Max. 30m	Max. 50m
Vertical height difference between outdoor unit and indoor unit	Max. 20m (Outdoor unit is higher) Max. 15m (Outdoor unit is lower)	Max. 30m (Outdoor unit is higher) Max. 15m (Outdoor unit is lower)
Power source voltage	Rating $\pm$ 10%	
Voltage at starting	Min. 85% of rating	
Frequency of ON-OFF cycle	Max. 10 times/h	
ON and OFF interval	Max. 3 minutes	



### 13.2.3 Exterior dimensions

(1) Indoor unit  
Model FDKN208C

Unit: mm

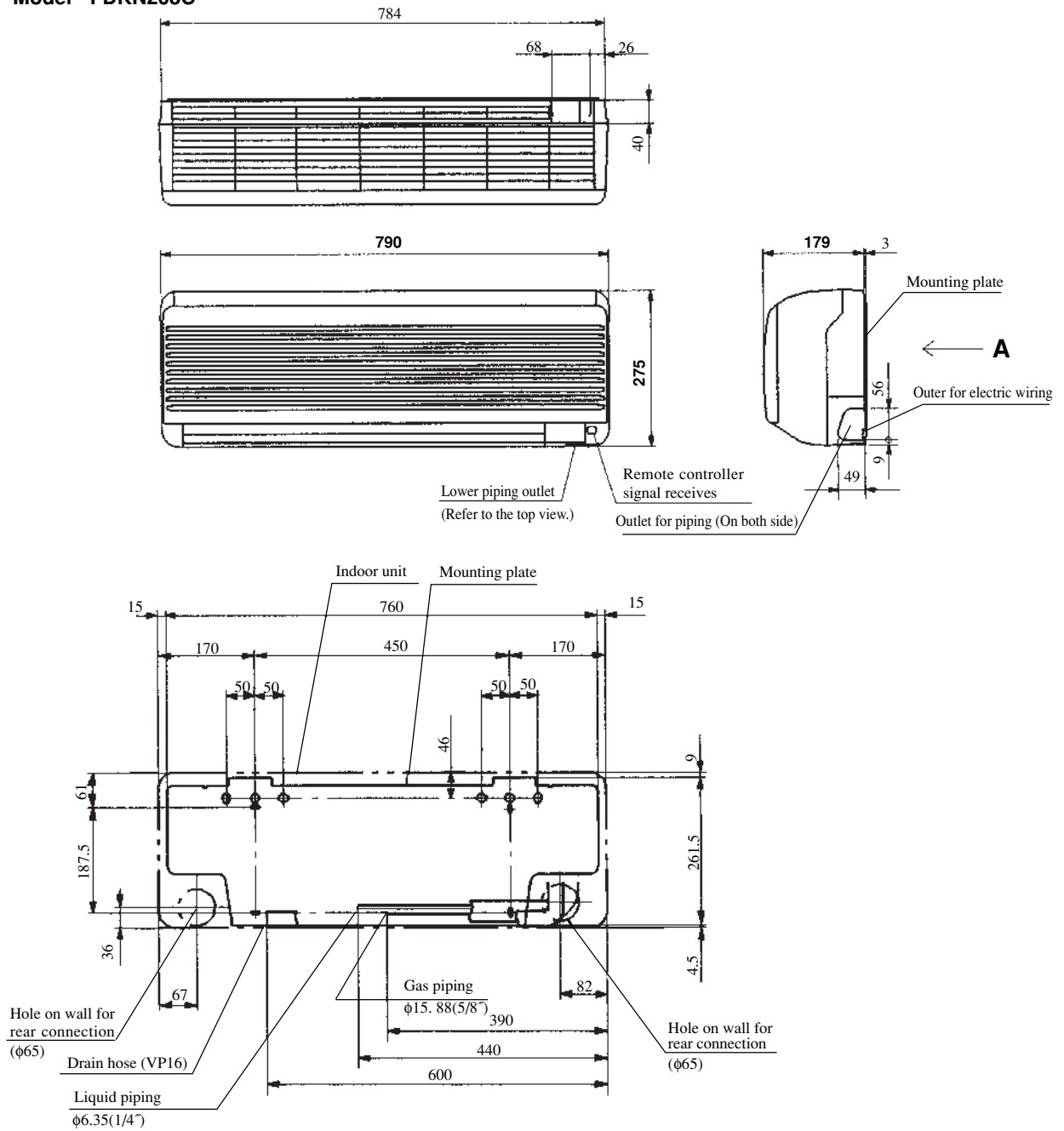

**VIEW A (Rear side)**

**Space for installation and service**

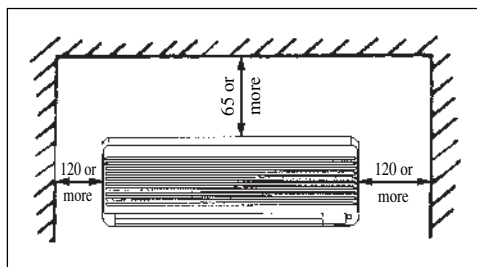

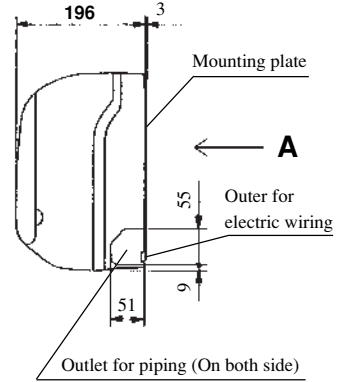
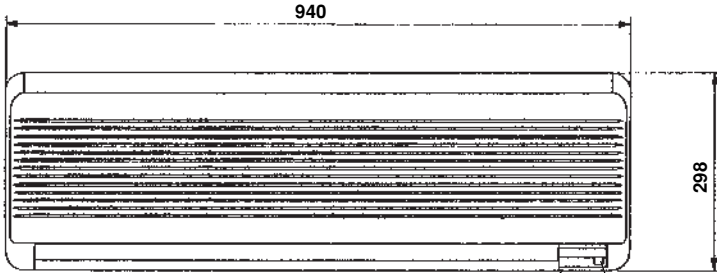
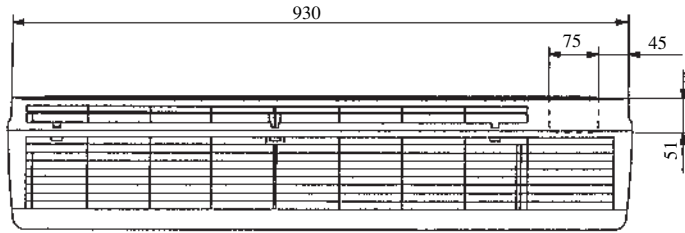

Lower piping outlet  
(Refer to the top view.)

Remote controller  
signal receives

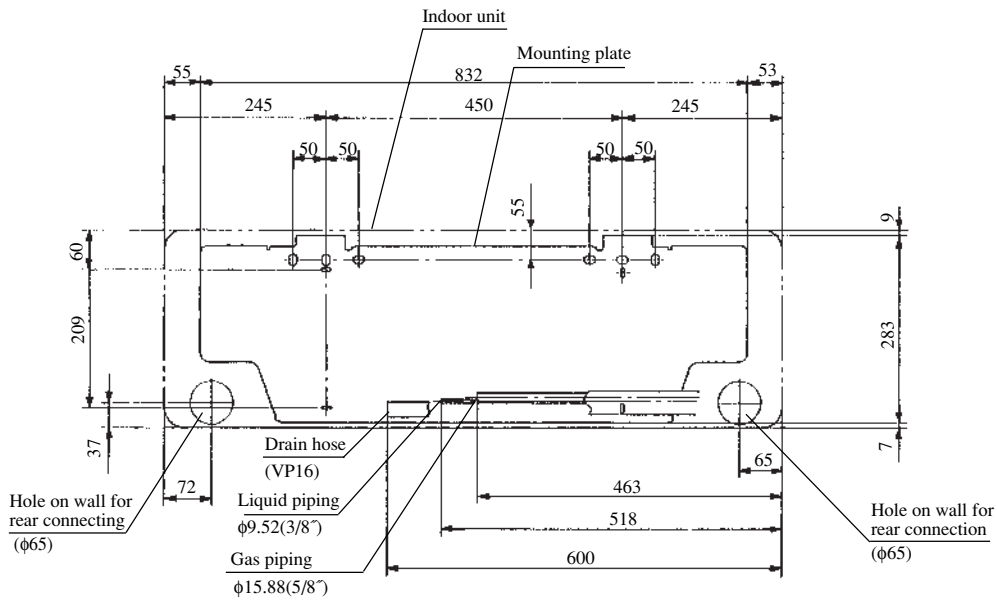

**VIEW A (Rear side)**

**Space for installation and service**

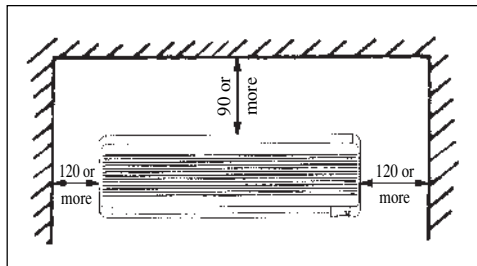

**Model FDKN308C**

Unit : mm

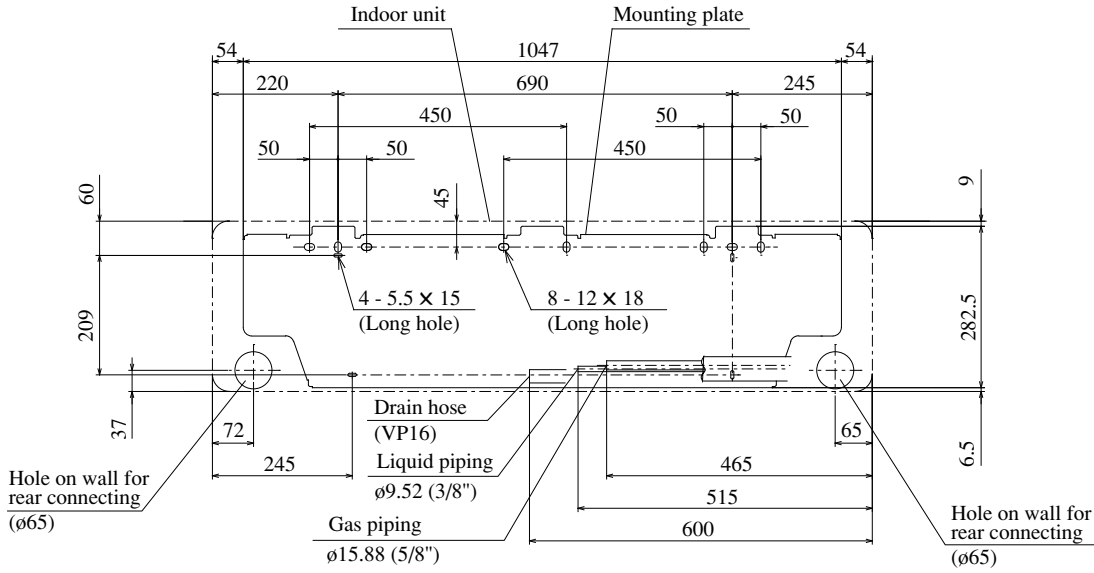
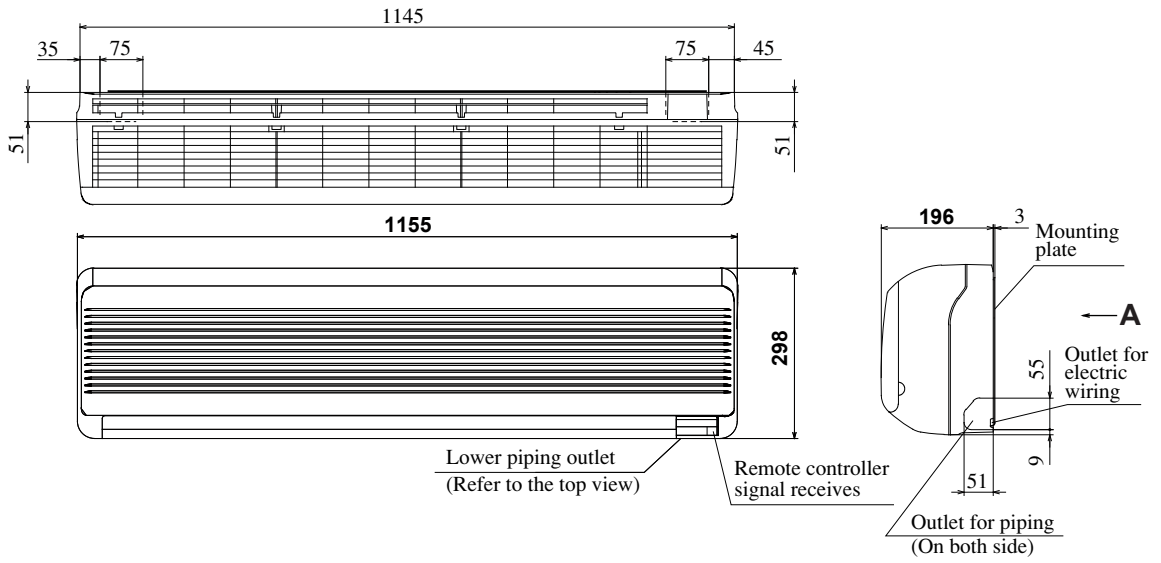

**VIEW A (Rear side)**

**Space for installation and service**

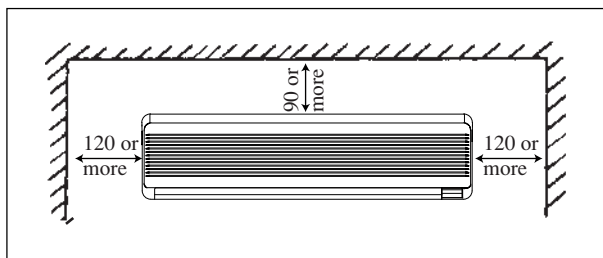

**(2) Wireless remote controller**

Unit : mm

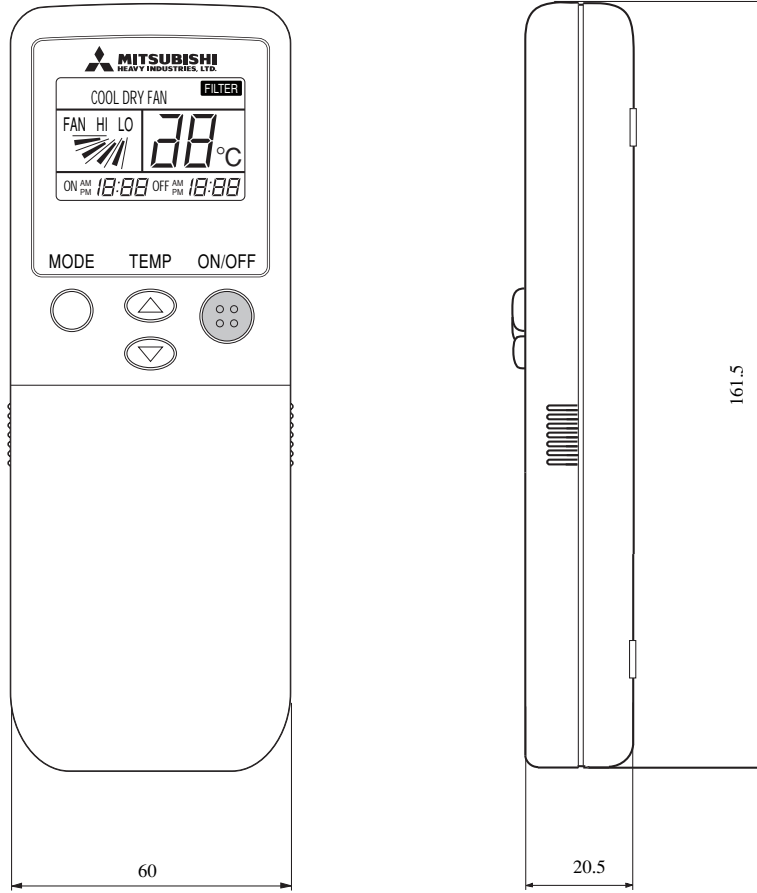

**(3) Indication board of indoor unit**

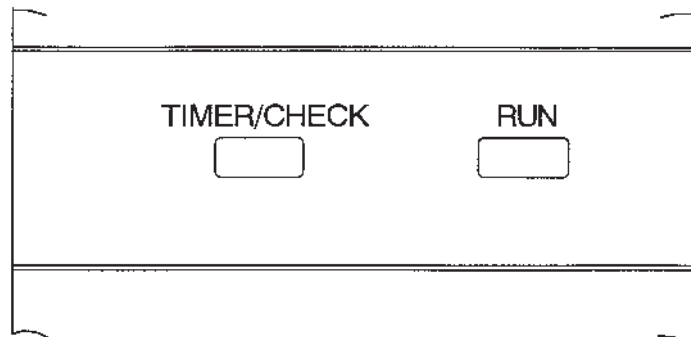

**(4) Outdoor unit**  
**Model FDCP208CEN3**

Unit: mm

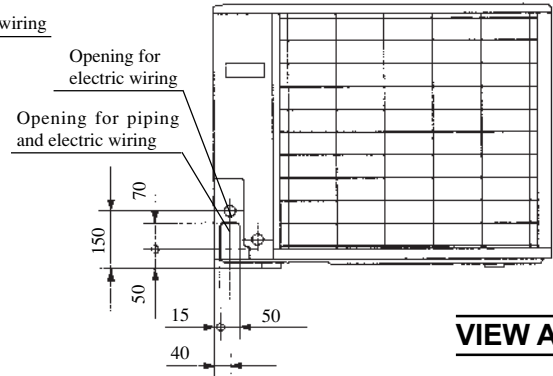
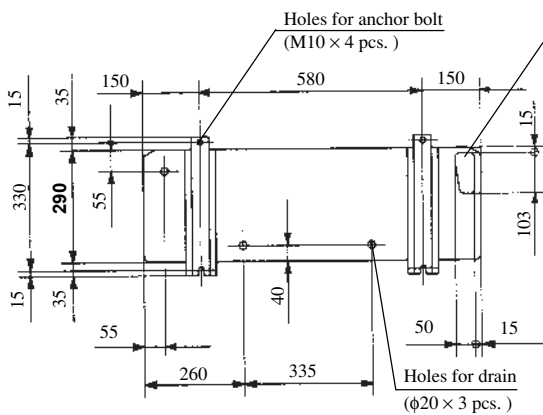
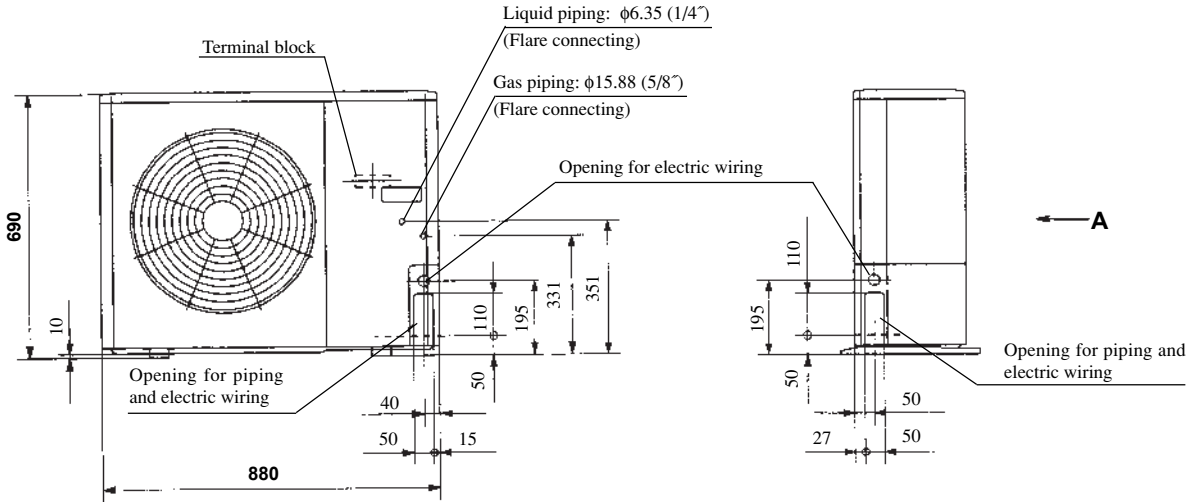
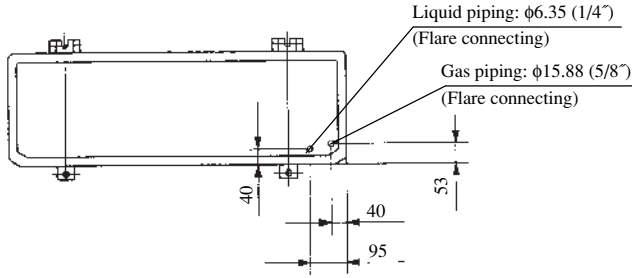

**Minimum allowable space to the obstacles**

Unit: mm

Mark	Installation type		
	I	II	III
L <sup>1</sup>	Open	Open	500
L <sup>2</sup>	300	5	Open
L <sup>3</sup>	100	150	100
L <sup>4</sup>	5	5	5

**Required space for maintenance and air flow**

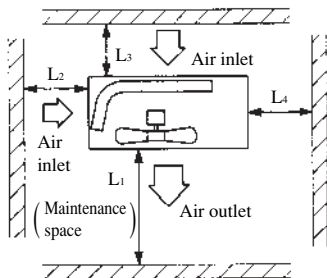

**Notes**

- (1) Avoid the location where four sides are entirely surrounded by walls.
- (2) Fix the unit by anchor bolts without fail. Restrict the protrusion length of anchor bolt to 15 mm and under.
- (3) When strong wind blows against the unit, direct the discharge port at a right angle to the wind direction.
- (4) Secure the space of 1 m and over at the top of unit.
- (5) Make the height of obstruction wall in front of discharge port lower than the height of unit.

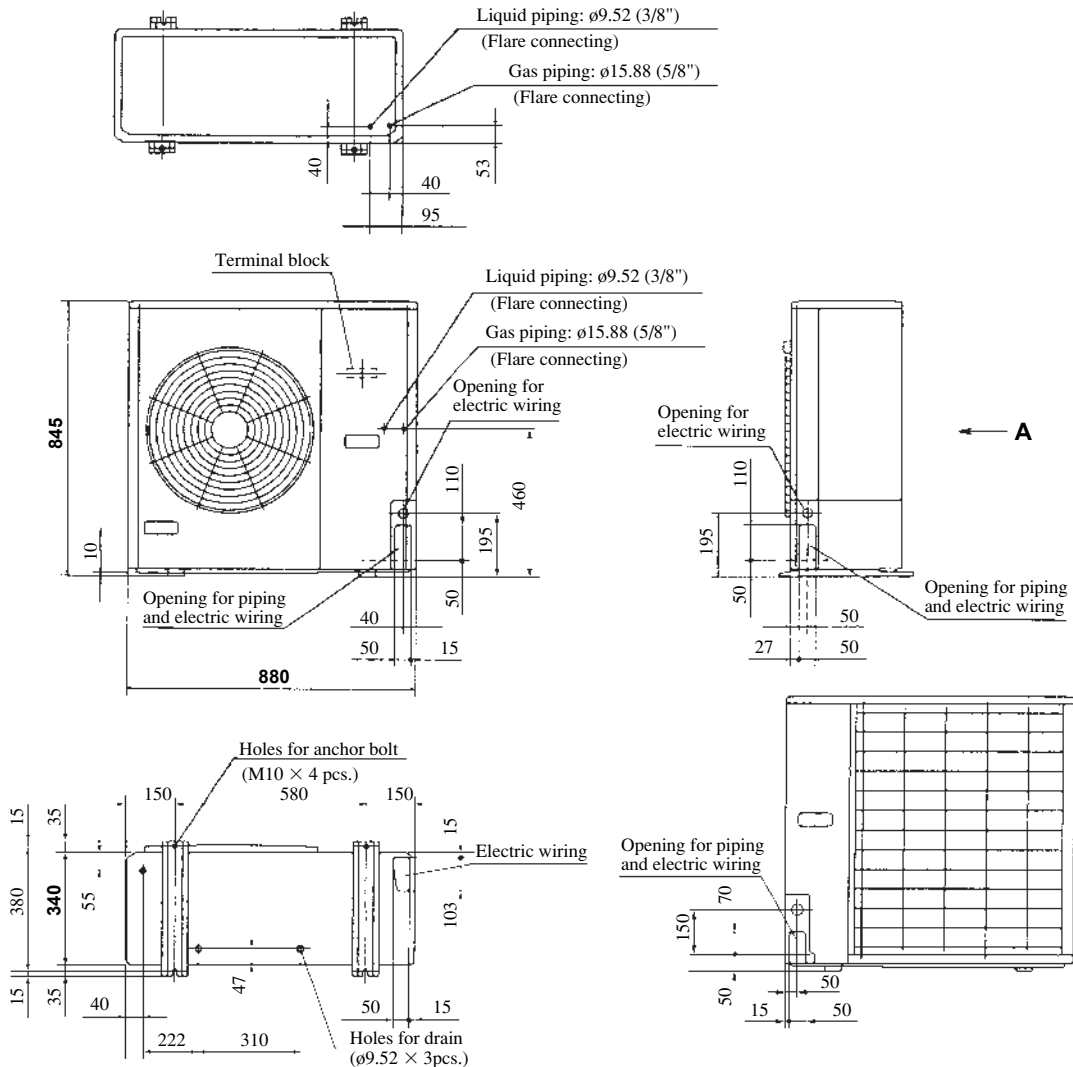

**VIEW A**

**Required space for maintenance and air flow**

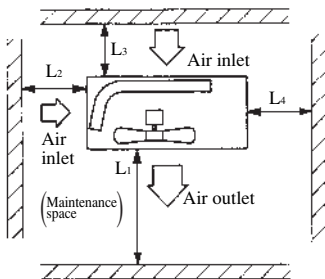

**Minimum allowable space to the obstacles**

		Unit:mm		
Mark	Installation type	I	II	III
		L1	Open	Open
L2		300	5	Open
L3		100	150	100
L4		5	5	5

**Notes**

- (1) Avoid the location where four sides are entirely surrounded by walls.
- (2) Fix the unit by anchor bolts without fail. Restrict the protrusion length of anchor bolt to 15 mm and under.
- (3) When strong wind blows against the unit, direct the discharge port at a right angle to the wind direction.
- (4) Secure the space of 1 m and over at the top of unit.
- (5) Make the height of obstruction wall in front of discharge port lower than the height of unit.

### 13.2.4 Exterior appearance

**(1) Indoor unit**

**Models All models**

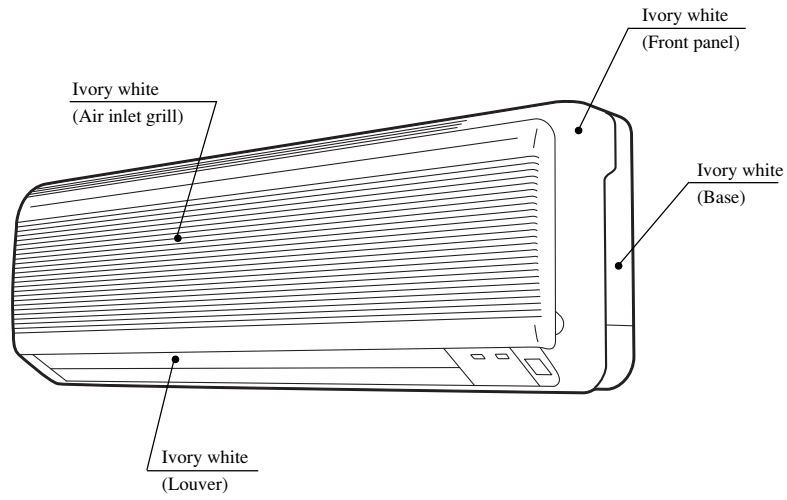

**(2) Outdoor unit**

**Model FDCP208CEN3**

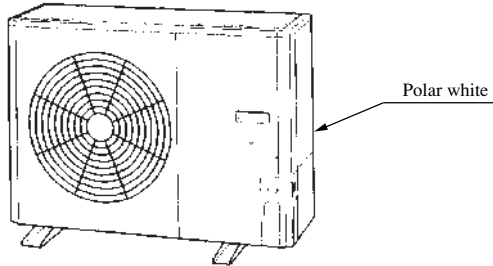

**Models FDCP258CEN3, 308CEN3  
308CES3**

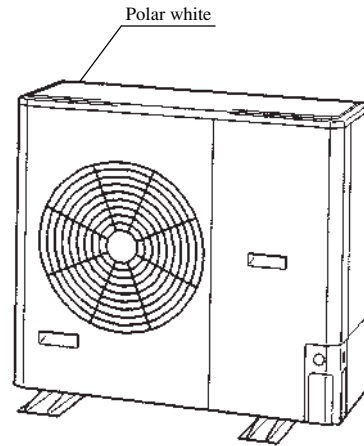

### 13.2.5 Piping system

Models **FDKNP208CEN-S, 258CEN-S**

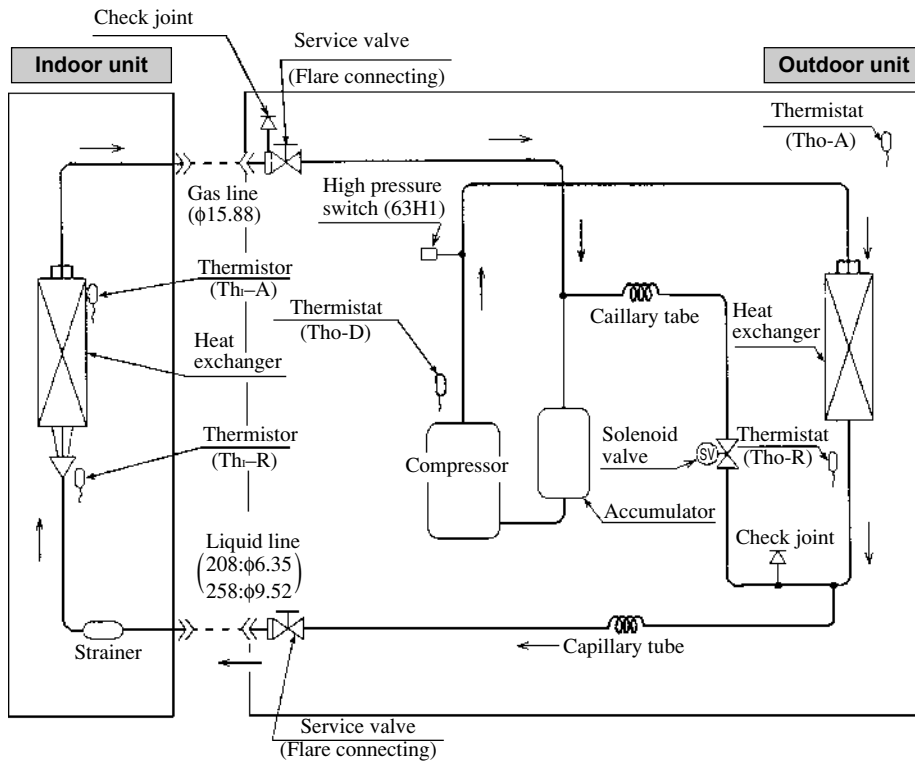

Models **FDKNP308CEN-S, 308CES-S**

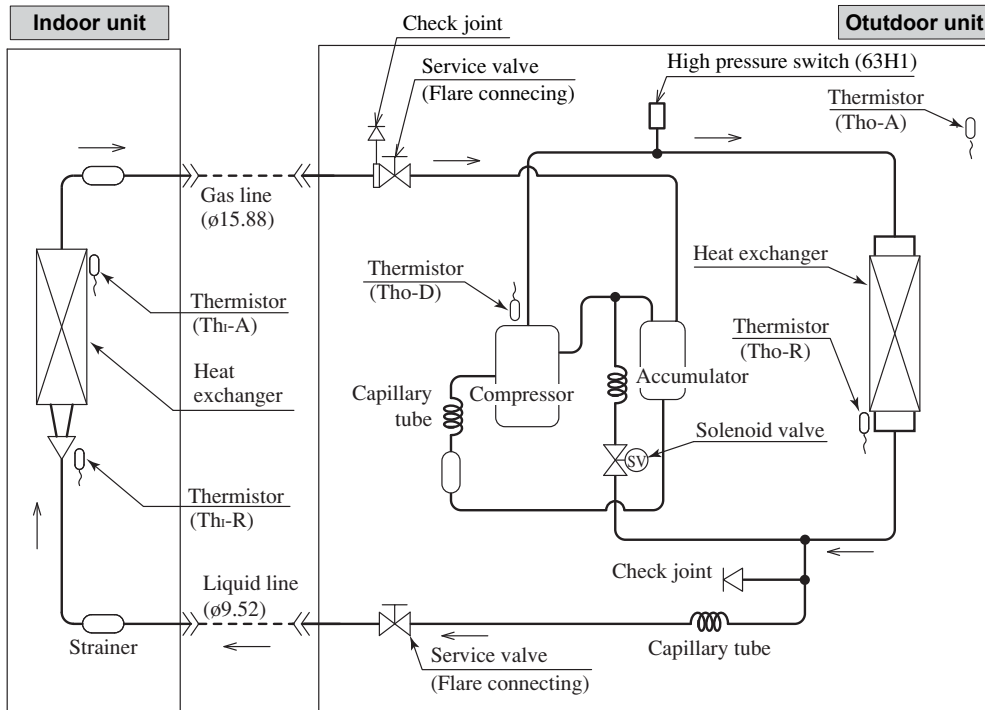



## Preset point of the protective devices

Parts name	Mark	Equipped unit	All models
Thermistor (for frost prevention)	Thi-R	Indoor unit	OFF 2.5°C ON 10°C
Thermistor (for detecting discharge pipe temp.)	Tho-D	Outdoor unit	OFF 135°C ON 90°C
Thermistor (for detecting heat exchanger temp.)	Tho-R	Outdoor unit	OFF 70°C ON 60°C
High pressure switch (for protection)	63Hi	Outdoor unit	OFF 3.24MPa (33 Kgf/cm <sup>2</sup> ) ON 2.65MPa (27 kgf/cm <sup>2</sup> )

### 13.2.6 Selection chart

Correct the cooling capacity in accordance with the conditions as follows. The net cooling capacity can be obtained in the following way.

**Net capacity = Capacity shown on specification × Correction factors as follows.**

**(1) Coefficient of cooling capacity in relation to temperatures**

**Models FDKNP208CEN-S, 258CEN-S**

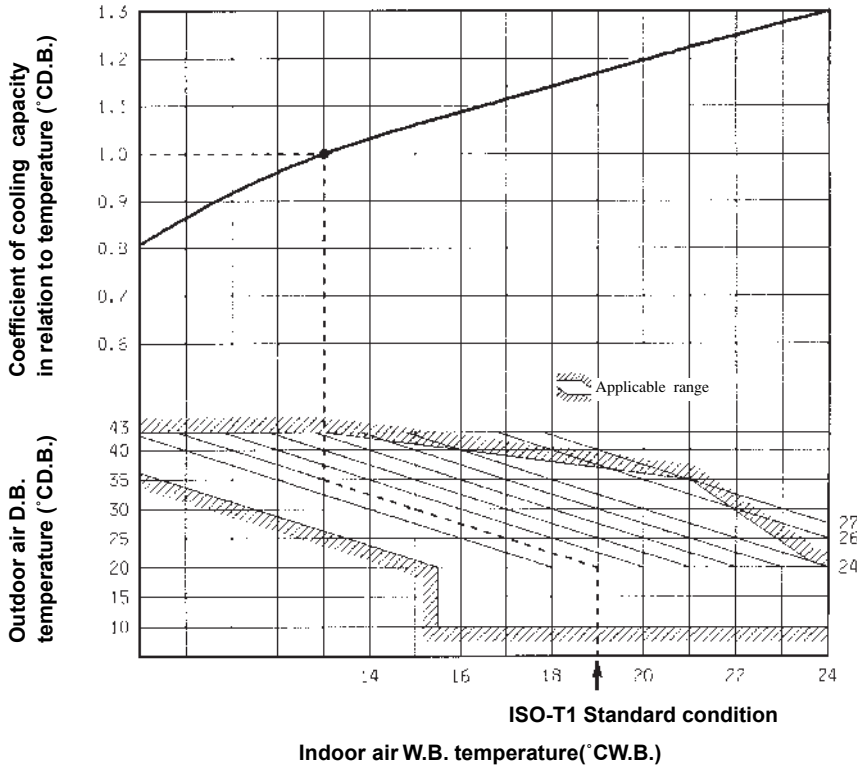

**Models FDKNP308CEN-S, 308CES-S**

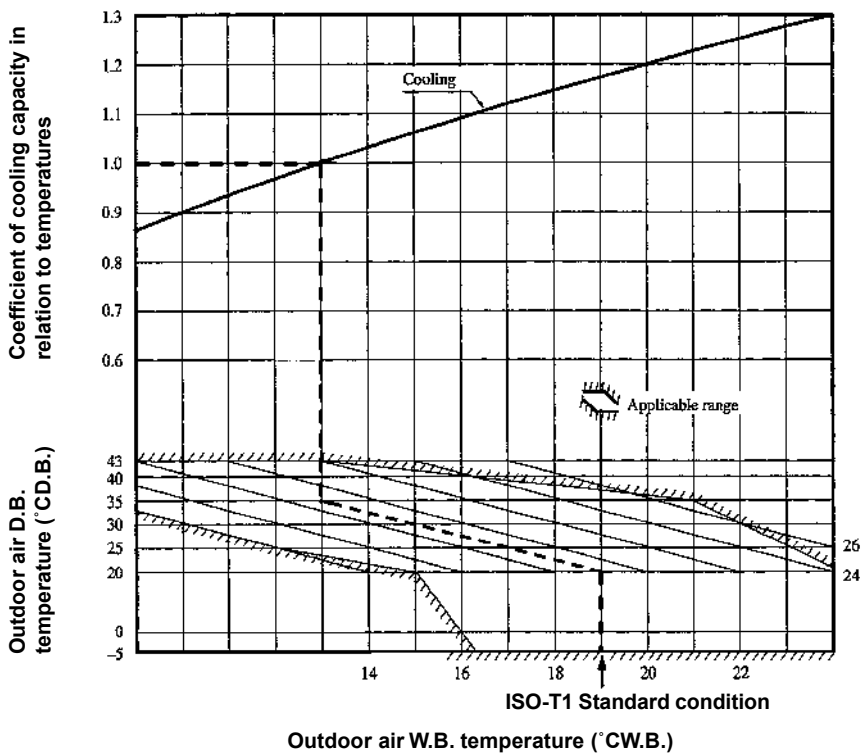

**Table of bypass factor**

Model		FDKN208C	FDKN258C	FDKN308C
Air flow	Hi	0.03	0.03	0.04

**(2) Correction of cooling capacity in relation to flow rate control (fan speed)**

**Coefficient: 1.00 at High, 0.95 at Low**

**(3) Correction of cooling capacity in relation to one way length of refrigerant piping**

It is necessary to correct the cooling capacity in relation to the one way equivalent piping length between the indoor and outdoor units.

Equivalent length <sup>(1)</sup> m		5	10	15	20	25	30	35	40	45	50	55
<b>Cooling</b>	208 type	1.0	0.995	0.995	0.99	0.985	0.985	0.98	-	-	-	-
	258 type	1.0	0.995	0.99	0.985	0.98	0.975	0.97	-	-	-	-
	308 type	1.0	0.99	0.98	0.97	0.96	0.95	0.94	0.93	0.92	0.91	0.9

Note (1) Equivalent piping length can be obtained by calculating as follows.

208, 258, 308 series [φ15.88(5/8")]: Equivalent piping length = Real piping length + (0.10 × Number of bends in piping)  
 [Equivalent piping length < Limitation length of piping + 5m]

**(4) When the outdoor unit is located at a lower height than the indoor unit in cooling operation,** the following values should be subtracted from the values in the above table.

Height difference between the indoor unit and outdoor unit in the vertical height difference	5m	10m	15m
Adjustment coefficient	0.01	0.02	0.03

**Piping length limitations**

Item	Model	FDKNP208, 258 type	FDKNP308 type
<b>Max.one way piping length</b>		30m	50m
<b>Max.vertical height difference</b>		20m(Outdoor unit is higher) 15m(Outdoor unit is lower)	30m(Outdoor unit is higher) 15m(Outdoor unit is lower)

Note (1) Values in the table indicate the one way piping length between the indoor and outdoor units.

**How to obtain the cooling capacity**

**Example :** The net cooling capacity of the model FDKNP308CEN-S with the air flow "High", the piping length of 15m, the outdoor unit located 5m lower than the indoor unit, indoor wet-bulb temperature at 19.0 °C and outdoor dry-bulb temperature 35 °C is

$$\text{Net cooling capacity} = \underset{\substack{\uparrow \\ \text{FDKNP308CEN-S}}}{7100} \times \underset{\substack{\uparrow \\ \text{Air flow "High"}}}{1.00} \times \underset{\substack{\uparrow \\ \text{Length 15m.} \\ \text{Height difference 5 m}}}{(0.98 - 0.01)} \times \underset{\substack{\uparrow \\ \text{Factor by air} \\ \text{temperatures}}}{1.0} = \mathbf{6887 \text{ w}}$$

### 13.2.7 Noise level

Notes (1) The data are based on the following conditions.  
 Ambient air temperature:  
 Indoor unit 27°C DB, 19°C WB  
 Outdoor unit 35°C DB,

**Indoor unit**  
 Measured based on JIS B 8616  
 Mike position as below



**Outdoor unit**  
 Measured based on JIS B 8616  
 Mike position: at highest noise level  
 in position as below  
 Distance from front side 1 m  
 Height 1 m

- (2) The data in the chart are measured in an unechoic room.
- (3) The noise levels measured in the field are usually higher than the data because of reflection.

**(1) Indoor unit**

**Model FDKN208C**

Noise level 45dB (A) at HIGH  
 38dB (A) at LOW

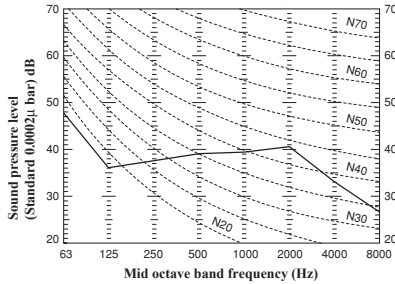

**Model FDKN258C**

Noise level 45dB (A) at HIGH  
 38dB (A) at LOW

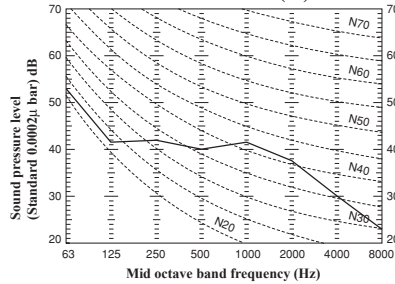

**Model FDKN308C**

Noise level 46dB (A) at HIGH  
 40dB (A) at LOW

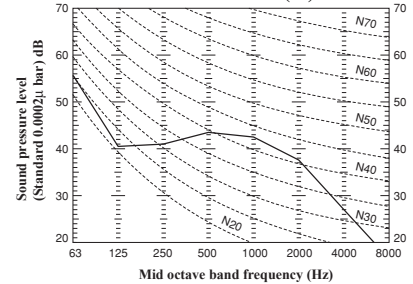

**(2) Outdoor unit**

**Model FDCP208CEN3**

Noise level 52dB (A)

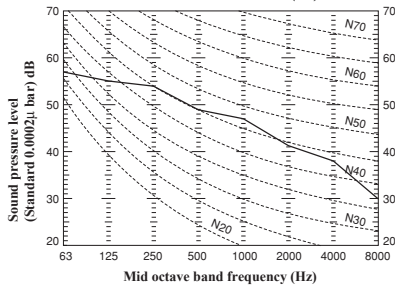

**Model FDCP258CEN3**

Noise level 52dB (A)

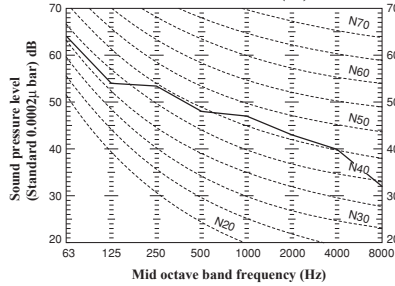

**Models FDCP308CEN3, 308CES3**

Noise level 52dB (A)

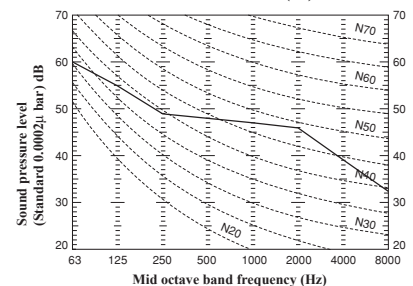

# 13.3 ELECTRICAL DATA

## 13.3.1 Electrical wiring

Model FDKNP208CEN-S

Power Source  
1 Phase 220/240V 50Hz

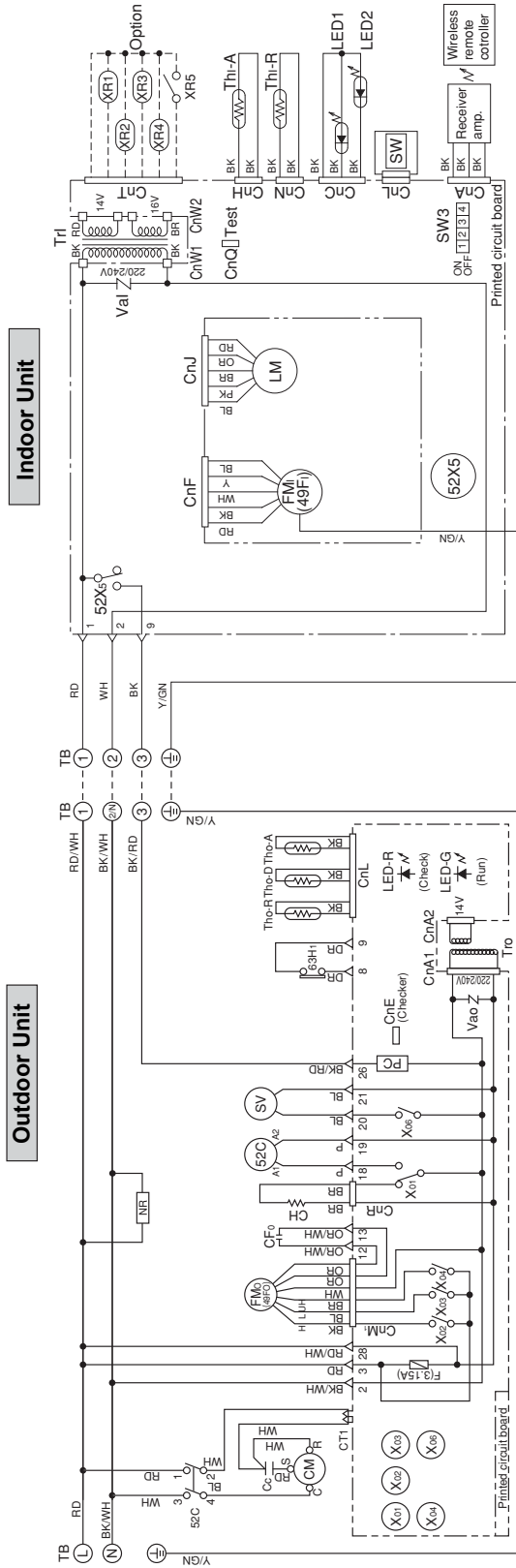

### Meaning of marks

Mark	Parts name	Mark	Parts name
Cc	Capacitor for CM	TB	Terminal block (O mark)
CFo	Capacitor for FMo	Thi-A	Thermistor
CH	Crankcase heater	Thi-R	Thermistor
CM	Compressor motor	Tho-A	Thermistor
CnA-W	Connector	Tho-D	Thermistor
F	Fuse	Tho-R	Thermistor
FMI	Fan motor (Indoor unit)	Tr, Tro	Transformer
FMo	Fan motor (Outdoor unit)	Vai, Vao	Varistor
LED1	Indication lamp (Green-Run)	49Fi	Internal thermostat for FMI
LED2	Indication lamp (Yellow-Timer/Check)	49Fo	Internal thermostat for FMo
LED-G	Indication lamp (Green)	CT1	Current sensor
LED-R	Indication lamp (Red)	63H	High pressure switch (for protection)
SV	Solenoid coil (for control)	52C	Magnetic contactor for CM
LM	Louver motor	52X5	Auxiliary relay
NR	Surge suppressor	X01-06	Auxiliary relay
PC	Photo coupler	▽	Terminal (F)
SW	Back up switch (ON/OFF)	■	Connector
SW3	Change over switch		

### Color mark

Mark	Color	Mark	Color
BK	Black	BK/RD	Black/Red
BL	Blue	BK/WH	Black/White
BR	Brown	OR/WH	Orange/White
GR	Gray	RD/WH	Red/White
OR	Orange	Y/GN	Yellow/Green
P	Pink		
RD	Red		
WH	White		
Y	Yellow		

**Models FDKNP258CEN-S, 308CEN-S**

**Power Source**  
1 Phase 220/240V 50Hz

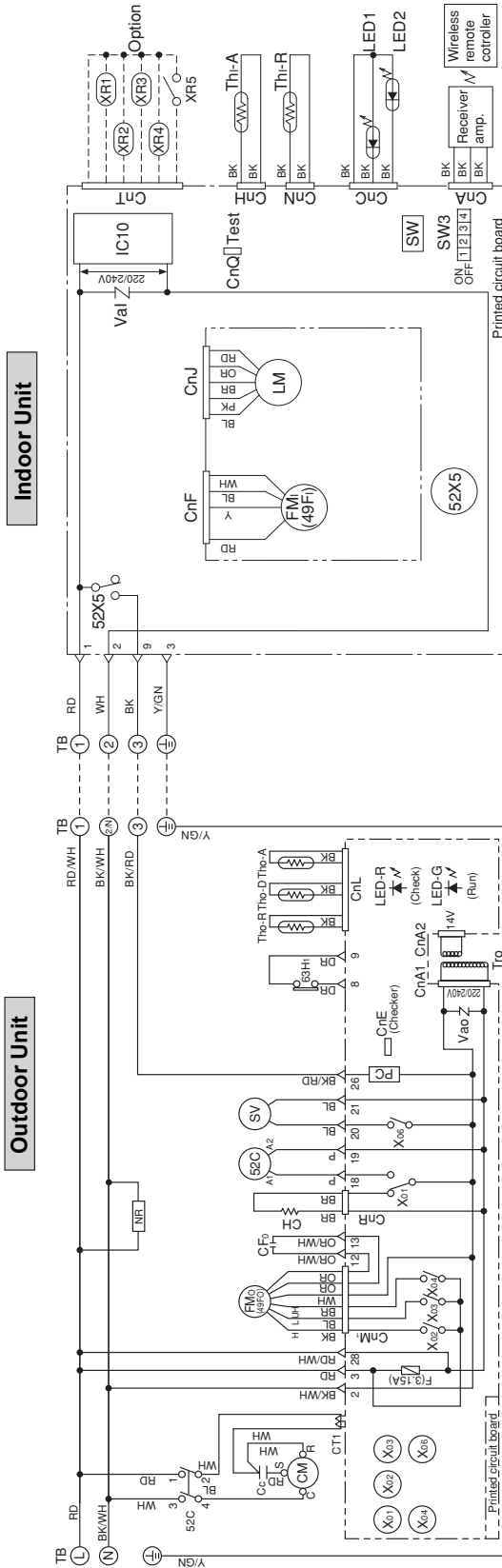

**Meaning of marks**

Mark	Parts name	Mark	Parts name
Cc	Capacitor for CM	TB	Terminal block (O mark)
CFo	Capacitor for FMo	Thi-A	Thermistor
CH	Crankcase heater	Thi-R	Thermistor
CM	Compressor motor	Tho-A	Thermistor
CnA-W	Connector	Tho-D	Thermistor
F	Fuse	Tho-R	Thermistor
FMi	Fan motor (Indoor unit)	Tr	Transformer
FMo	Fan motor (Outdoor unit)	Va, Vao	Varistor
LED1	Indication lamp (Green-Run)	49Fi	Internal thermostat for FMi
LED2	Indication lamp (Yellow-Timer/Check)	CT1	Current sensor
LED-G	Indication lamp (Green)	63H	High pressure switch (for protection)
LED-R	Indication lamp (Red)	52C	Magnetic contactor for CM
SV	Solenoid coil (for control)	52X5	Auxiliary relay
LM	Louver motor	X01-06	Auxiliary relay
NR	Surge suppressor	▽	Terminal (F)
PC	Photo coupler	■	Connector
SW	Back up switch (ON/OFF)		
SW3	Change over switch		

**Color mark**

Mark	Color	Mark	Color
BK	Black	BK/RD	Black/Red
BL	Blue	BK/WH	Black/White
BR	Brown	OR/WH	Orange/White
GR	Gray	RD/WH	Red/White
OR	Orange	Y/GN	Yellow/Green
P	Pink		
RD	Red		
WH	White		
Y	Yellow		

**Model FDKNP308CES-S**

**Power Source  
3 Phase 380/415V 50Hz**

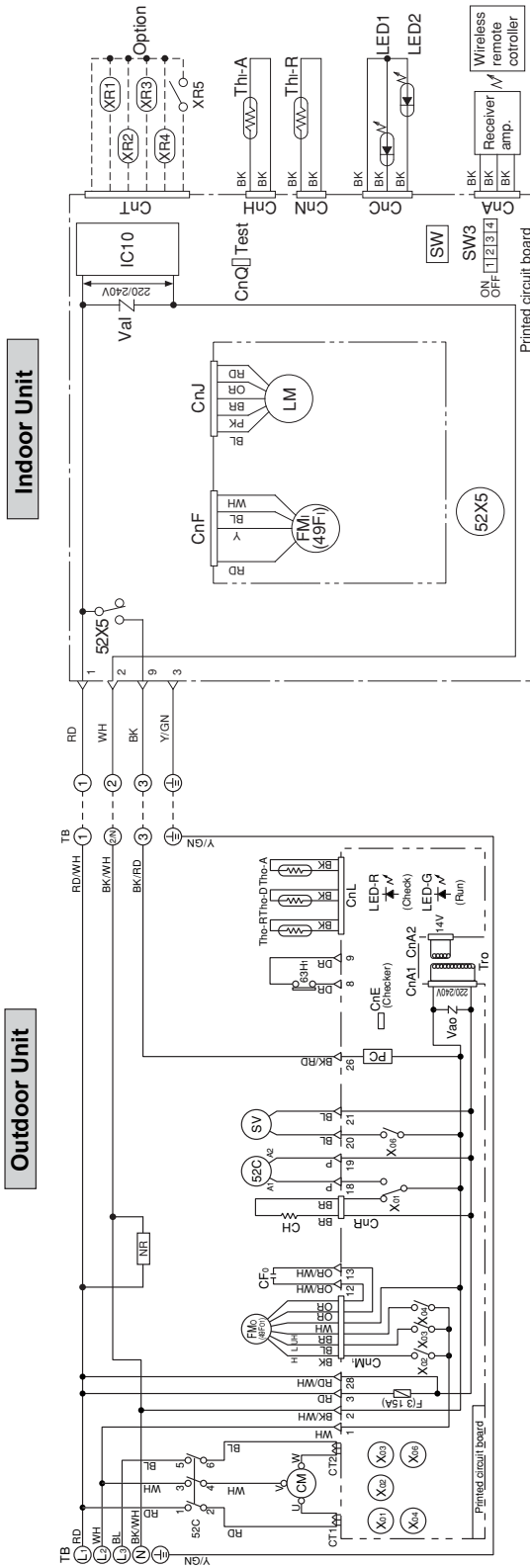

**Meaning of marks**

Mark	Parts name	Mark	Parts name
CFo	Capacitor for FMo	TB	Terminal block (O mark)
CH	Crankcase heater	Th-A	Thermistor
CM	Compressor motor	Th-R	Thermistor
CnA-W	Connector	Tho-A	Thermistor
F	Fuse	Tho-D	Thermistor
FMi	Fan motor (Indoor unit)	Tr, Tro	Transformer
FMo	Fan motor (Outdoor unit)	Vai, Vao	Varistor
LED1	Indication lamp (Green-Run)	49F1	Internal thermostat for FMi
LED2	Indication lamp (Yellow-Timer/Check)	49Fo	Internal thermostat for FMo
LED-G	Indication lamp (Green)	CT1, 2	Current sensor
LED-R	Indication lamp (Red)	63H1	High pressure switch (for protection)
SV	Solenoid coil (for control)	52C	Magnetic contactor for CM
LM	Louver motor	52X5	Auxiliary relay
NR	Surge suppressor	X01-06	Auxiliary relay
PC	Photo coupler	▽	Terminal (F)
SW	Back up switch (ON/OFF)	■	Connector
SW3	Change over switch		

**Color mark**

Mark	Color	Mark	Color
BK	Black	BK/RD	Black/Red
BL	Blue	BK/WH	Black/White
BR	Brown	OR/WH	Orange/White
GR	Gray	RD/WH	Red/White
OR	Orange	Y/GN	Yellow/Green
P	Pink		
RD	Red		
WH	White		
Y	Yellow		

## **13.4 OUTLINE OF OPERATION CONTROL BY MICROCOM- PUTER**

Except for function relating to heating, same as the unit for FDT(N) heat pump type. See page 317.

## **13.5 APPLICATION DATA**

The application data for the cooling only models are similar to those for the heat pump models. (See page 497.)

## **13.6 MAINTENANCE DATA**

Same as the cooling/heating equipment for FDT(N) heat pump type. Refer to page 348.