

19. INVERTER DRIVEN MULTI-INDOOR UNIT CLIMATE CONTROL SYSTEM

(OUTDOOR UNIT)

Refrigerant R22 use models

FDCJ140HKXE2B, 224HKXE2B, 280HKXE2B

Alternative refrigerant R407C use models

FDCP140HKXE2B, 224HKXE2B, 280HKXE2B

(INDOOR UNIT)

FDTJ28HKXE2	FDTWJ28HKXE2B	FDTSJ22HKXE2B	FDRJ22HKXE2
36HKXE2	45HKXE2B	28HKXE2B	28HKXE2
45HKXE2	56HKXE2B	36HKXE2B	45HKXE2
56HKXE2	71HKXE2B	45HKXE2B	56HKXE2
71HKXE2	90HKXE2B	71HKXE2B	71HKXE2
90HKXE2	112HKXE2B		90HKXE2
112HKXE2	140HKXE2B		112HKXE2
140HKXE2			140HKXE2
FDUMJ36HKXE2	FDEJ36HKXE2B	FDKJ22HKXE2	FDFLJ28HKXE2
45HKXE2	45HKXE2B	28HKXE2	45HKXE2
56HKXE2	56HKXE2B	36HKXE2	71HKXE2
71HKXE2	71HKXE2B	45HKXE2	FDFUJ28HKXE2
90HKXE2	112HKXE2B	56HKXE2	45HKXE2
112HKXE2	140HKXE2B	71HKXE2	56HKXE2
140HKXE2			71HKXE2

CONTENTS

19.1 GENERAL INFORMATION	725
19.1.1 Specific features	725
19.1.2 How to read the model name	727
19.1.3 Table of models	727
19.1.4 Table of indoor units panel (Optional)	727
19.2 SELECTION DATA	728
19.2.1 Specifications	728
19.2.2 Range of usage & limitations	757
19.2.3 Exterior dimensions	758
19.2.4 Exterior appearance	783
19.2.5 Piping system	786
19.2.6 Selection chart	788
19.2.7 Characteristic of fan	803
19.2.8 Noise level	808
19.3 ELECTRICAL DATA	814
19.3.1 Electrical wiring	814
19.4 OUTLINE OF OPERATION CONTROL BY MICROCOMPUTER	824
19.5 APPLICATION DATA	840
19.5.1 Installation of indoor unit	841
19.5.2 Installation of the remote controller (Optional Parts)	882
19.5.3 Installation of outdoor unit	884
19.5.4 Refrigerant piping	888
19.5.5 Electric wiring	894
19.5.6 Test run	903
19.6 MAINTENANCE DATA	904

19.1 GENERAL INFORMATION

19.1.1 Specific features

(1) Fuzzy control

(a) Response speed and stability are enhanced.

- The system automatically controls changes of return air temperature, set temperature and room temperature according to the fuzzy control.
- The system response speed, can keep room temperature constant, and can adjust room temperature to set temperature quickly.

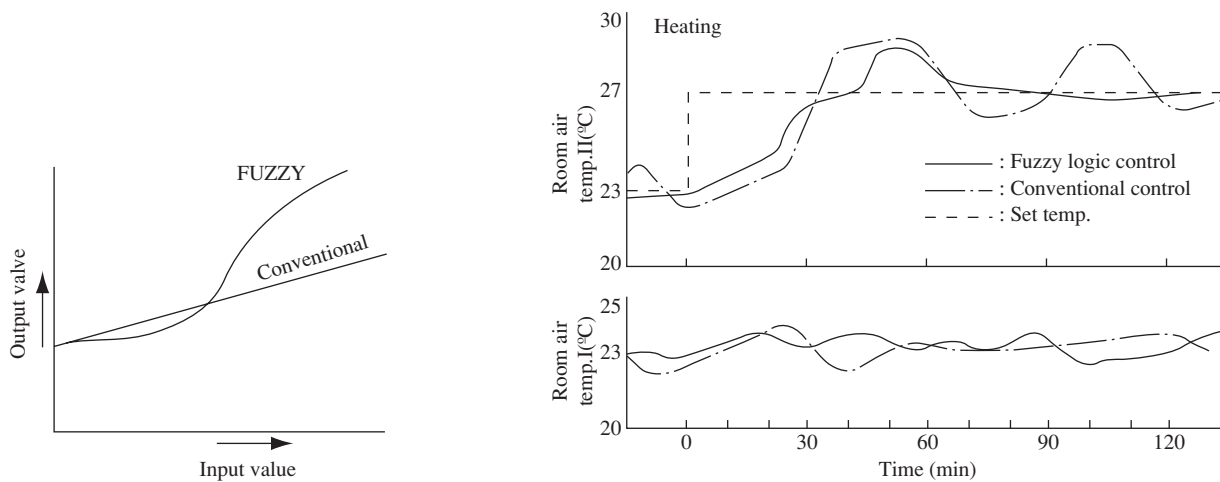
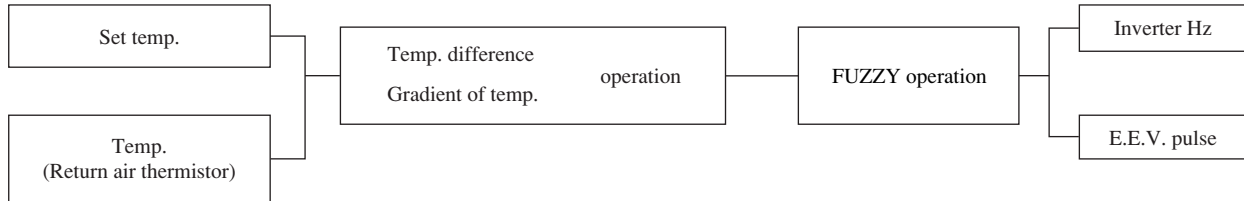

(b) Elimination of temperature irregularity as the time of operation ON/OFF control

- The system finely controls the compressor to room temperature according to the temperature sensor, air conditions room temperature consistently and improves cooling or heating feeling in each room(or minimize influence of shutdown in other room).

(2) Super lynk system

- Non polar 2-core signal wires for indoor, outdoor units by means of the automatic polarity selection.
- In addition, the max. 48 units can be controlled with a pair of signal wires. The high speed transmission method same as the computer network system [start up of 48 units can be completed within a few seconds by the determination of operation mode and the start of operation].
- As separate power supplies for the indoor and the outdoor units are employed, a pair of 2 signal wires only are required for the inter connecting wiring of indoor and outdoor units regardless of the number of units so that the installation work can be simplified, the cost of wiring work can be curtailed and causes of wiring error can be minimized.

(3) Floor layout can be changed by resetting address unit number.

- For change of floor layout, the control group can be recombined only by resetting address unit number.

(4) Installation of automatic address setting function

- The address setting method are divided into three types according to wiring method: “Automatic Address Setting,” “Remote controller Address Setting” and “Manual Address Setting.” In case of the Automatic Address Setting, no address needs be set as usual.

(5) Connectable indoor capacity

Capacity from 50% to 130% is possible.

- FDCJ(P)140 type

Number of connectable units : 1 to 8 units

Connectable capacity : 7000 ~ 18200 W

- FDCJ(P)224 type

Number of connectable units : 1 to 13 units

Connectable capacity : 11200 ~ 29200 W

- FDCJ(P)280 type

Number of connectable units : 1 to 16 units

Connectable capacity : 14000 ~ 36400 W

(6) Cooling operation down to -5°C outdoor temperature

(7) Indoor units are available with 9 capacities, in 9 types and 54 models.

- 9 capacities...22(0.8 HP), 28(1 HP), 36(1.25 HP), 45(1.6 HP), 56(22 HP), 71(2.5 HP), 90(3.2 HP), 112(4 HP) and 140(5 HP).
- 9 types...Ceiling recessed type (FDT), 2-way outlet ceiling recessed type(FDTW), 1-way outlet ceiling recessed type(FDTS), Casseteria type(FDR), Satellite ducted type(FDUM), Ceiling suspension type(FDE), Wall mounted type(FDK), Floor standing exposed type(FDFL) and Floor standing hidden type (FDFU).

(8) Vertical blow or horizontal blow type can be selected for the outdoor unit.

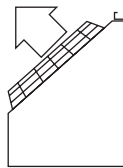

Standard

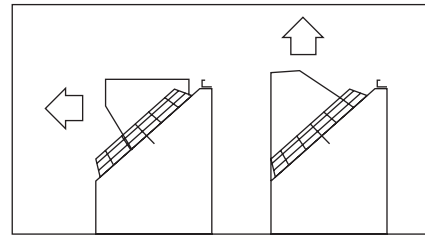

horizontal blow

Vertical blow

Using an adapter
(Optional)

(9) Long piping design offers One way piping length of 100 m

- Indoor and outdoor units can have a level difference of up to 50 m, with a one way piping length of up to 100 m. This is the top-class long piping design in the industry. A level difference of as much as 15 m between indoor units ensures that the system can meet a wide variety of air conditioning requirements in any building.

(10) Layout free refrigerant piping

The branch type piping makes the system flexible enough to satisfy any layout plan on the floor or in a room.

(11) Improvement of serviceability

- Failures of indoor unit and outdoor units are shown on the liquid crystal display on the remote controller.
 - Failures of indoor unit and outdoor units can be checked by remote controller.
- Easy checking of outdoor inspection LED.
 - The LED can be checked without removing the service panel, and faulty units can be easily indentified out of several units.

19.1.2 How to read the model name

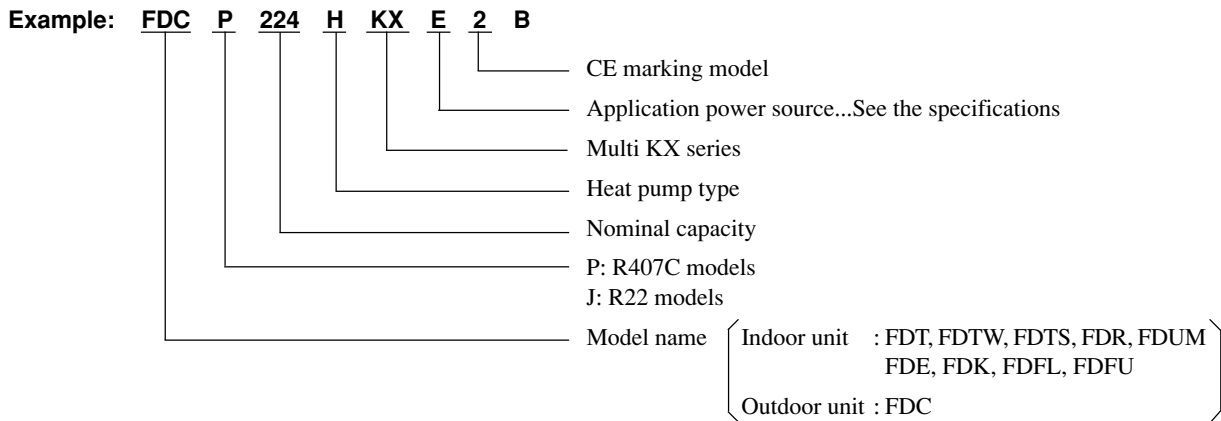

19.1.3 Table of models

Model		Capacity								
		22	28	36	45	56	71	90	112	140
Ceiling recessed type (FDT)			○	○	○	○	○	○	○	○
2-way outlet ceiling recessed type (FDTW)			○		○	○	○	○	○	○
1-way outlet ceiling recessed type (FDTS)		○	○	○	○		○			
Casseteria type (FDR)		○	○		○	○	○	○	○	○
Stellite ducted type (FDUM)				○	○	○	○	○	○	○
Ceiling suspension type (FDE)				○	○	○	○		○	○
Wall mounted type (FDK)		○	○	○	○	○	○			
Floor standing exposed type (FDFL)			○		○		○			
Floor standing hidden type (FDFU)			○		○	○	○			
Outdoor units to be combined FDC	R407C models	FDCP140HKXE2B (5 Horse Power)			FDCP224HKXE2B (8 Horse Power)			FDCP280HKXE2B (10 Horse Power)		
	R22 models	FDCJ140HKXE2B (5 Horse Power)			FDCJ224HKXE2B (8 Horse Power)			FDCJ280HKXE2B (10 Horse Power)		

19.1.4 Table of indoor units panel (Optional)

Model	Capacity	Parts Model
FDT	Capacity:28,36,45,56,71,90,112,140	T-PSA-32W-E
FDTW (Standard type)	Capacity:28,45,56	TW-PSA-22W-E
	Capacity:71,80	TW-PSA-32W-E
	Capacity:112,140	TW-PSA-42W-E
FDTW (Attachment of ceiling material type)	Capacity:28,45,56	TW-PSB-28W-E
	Capacity:71,90	TW-PSB-38W-E
	Capacity:112,140	TW-PSB-48W-E
FDTS	Capacity:22,28,36,45	TS-PSA-26W-E
	Capacity:71	TS-PSA-36W-E
FDR (Silent type)	Capacity:22,28,45,56	R-PNLS-26W-E
	Capacity:71,90	R-PNLS-36W-E
	Capacity:112,140	R-PNLS-46W-E
FDR (Canvas type)	Capacity:22,28,45,56	R-PNLC-26W-E
	Capacity:71,90	R-PNLC-36W-E
	Capacity:112,140	R-PNLC-46W-E

19.2 SELECTION DATA

19.2.1 Specifications

(1) Indoor unit

(a) Ceiling recessed type (FDT)

Models FDTJ28HKXE2, 36HKXE2

Item	Models	FDTJ28HKXE2 ⁽³⁾	FDTJ36HKXE2 ⁽³⁾
		Nominal cooling capacity* ¹	W
Nominal heating capacity* ²	W	3200	4000
Power source		1 Phase 220/240V 50Hz	
Noise level	dB(A)	Hi: 37 Me: 34 Lo: 33	
Exterior dimensions Height × Width × Depth	mm	Unit:260 × 840 × 840 Panel:30 × 950 × 950	
Net weight	kg	Unit:24 Panel:7	
Refrigerant equipment Heat exchanger		Louver fine & inner grooved tubing	
Refrigerant control		Electronic Expansion Valve +Capillary tube	
Air handling equipment Fan type & Q'ty		Turbo fan × 1	
Motor	W	17 × 1	
Starting method		Line starting	
Air flow(Standard)	CMM	Hi: 12 Me: 10 Lo: 9	
Fresh air intake		Possible	
Air filter, Q'ty		Long life filter × 1(Washable)	
Shock & vibration absorber		Rubber sleeve(for fan motor)	
Insulation (noise & heat)		Polyurethane foam	
Operation control Operation switch		Remote control switch (Optional:RCD-HKX-S-E2)	
Room temperature control		Thermostat by electronics	
Safety equipment		Internal thermostat for fan motor. Frost protection thermostat	
Installation data Refrigerant piping size	mm(in)	Liquid line:φ6.35(1/4"), Gas line:φ12.7(1/2")	
Connecting method		Flare piping	
Drain hose		Connectable with VP25	
Insulation for piping		Necessary (both Liquid & Gas line)	
Accessories		Mounting kit	
Optional parts		Decorative Panel	
Outdoor units to be combined		FDCJ140HKXE2B,224HKXE2B,280HKXE2B,FDCP140HKXE2B,224HKXE2B,280HKXE2B	

Notes (1) The data are measured at the following conditions.

Item	Indoor air temperature		Outdoor air temperature		Standards
	DB	WB	DB	WB	
Operation Cooling* ¹	27℃	19℃	35℃	24℃	ISO-T1,JIS B8616
Heating* ²	20℃	—	7℃	6℃	

(2) This packaged air-conditioner is manufactured and tested in conformity with the following standard.
JIS B8616"UNITARY AIR-CONDITIONERS"

●Decorative Panel model (Optional)

Model	Item	Panel Part No.
FDTJ28,36 type		T-PSA-32W-E

(3) The number "2", following the type of each model, represents"CE-marked model" especially for European Union, and for European nations which require CE marking.

Models FDTJ45HKXE2, 56HKXE2, 71HKXE2

Item	Models	FDTJ45HKXE2 ⁽³⁾	FDTJ56HKXE2 ⁽³⁾	FDTJ71HKXE2 ⁽³⁾
		Nominal cooling capacity* ¹	W	4500
Nominal heating capacity* ²	W	5000	6300	8000
Power source		1 Phase 220/240V 50Hz		
Noise level	dB(A)	Hi: 38 Me: 35 Lo: 34		Hi: 40 Me: 38 Lo: 36
Exterior dimensions Height × Width × Depth	mm	Unit:260 × 840 × 840 Panel:30 × 950 × 950		
Net weight	kg	Unit:24 Panel:7		
Refrigerant equipment Heat exchanger		Louver fine & inner grooved tubing		
Refrigerant control		Electronic Expansion Valve +Capillary tube		
Air handling equipment Fan type & Qty		Turbo fan × 1		
Motor	W	20 × 1		25 × 1
Starting method		Line starting		
Air flow(Standard)	CMM	Hi: 15 Me: 12 Lo: 10		Hi: 16 Me: 13 Lo: 11
Fresh air intake		Possible		
Air filter, Qty		Long life filter × 1(Washable)		
Shock & vibration absorber		Rubber sleeve(for fan motor)		
Insulation (noise & heat)		Polyurethane foam		
Operation control Operation switch		Remote control switch (Optional:RCD-HKX-S-E2)		
Room temperature control		Thermostat by electronics		
Safety equipment		Internal thermostat for fan motor. Frost protection thermostat		
Installation data Refrigerant piping size	mm(in)	Liquid line:φ 6.35(1/4") Gas line:φ 12.7(1/2")	Liquid line:φ 9.52(3/8") Gas line:φ 15.88(5/8")	
Connecting method		Flare piping		
Drain hose		Connectable with VP25		
Insulation for piping		Necessary (both Liquid & Gas lines)		
Accessories		Mounting kit		
Optional parts		Decorative Panel		
Outdoor units to be combined		FDCJ140HKXE2B,224HKXE2B,280HKXE2B,FDCP140HKXE2B,224HKXE2B,280HKXE2B		

Notes (1) The data are measured at the following conditions.

Item	Indoor air temperature		Outdoor air temperature		Standards
	DB	WB	DB	WB	
Cooling* ¹	27℃	19℃	35℃	24℃	ISO-T1,JIS B8616
Heating* ²	20℃	—	7℃	6℃	

(2) This packaged air-conditioner is manufactured and tested in conformity with the following standard.
JIS B8616"UNITARY AIR-CONDITIONERS"

●Decorative Panel model (Optional)

Item	Panel Part No.
Model FDTJ45,56,71 type	T-PSA-32W-E

(3) The number "2", following the type of each model, represents "CE-marked model" especially for European Union, and for European nations which require CE marking.

Models FDTJ90HKXE2, 112HKXE2, 140HKXE2

Item	Models	FDTJ90HKXE2 ⁽⁹⁾	FDTJ112HKXE2 ⁽⁹⁾	FDTJ140HKXE2 ⁽³⁾
Nominal cooling capacity* ¹	W	9000	11200	14000
Nominal heating capacity* ²	W	10000	12500	16000
Power source		1 Phase 220/240V 50Hz		
Noise level	dB(A)	Hi: 42 Me: 40 Lo: 39	Hi: 49 Me:46 Lo: 42	Hi: 50 Me: 47 Lo: 45
Exterior dimensions Height × Width × Depth	mm	Unit: 260 × 840 × 840 Panel:30 × 950 × 950	Unit: 320 × 840 × 840 Panel:30 × 950 × 950	
Net weight	kg	Unit:24 Panel:7	Unit:28 Panel:7	Unit:30 Panel:7
Refrigerant equipment Heat exchanger		Louver fins & inner grooved tubing		
Refrigerant control		Electronic Expansion Valve +Capillary tube		
Air handling equipment Fan type & Qty		Turbo fan × 1		
Motor	W	50 × 1	80 × 1	130 × 1
Starting method		Line starting		
Air flow(Standard)	CMM	Hi: 21 Me: 15 Lo: 12	Hi: 28 Me: 24 Lo: 21	Hi: 30 Me: 26 Lo: 22
Fresh air intake		Possible		
Air filter, Qty		Long life filter × 1(Washable)		
Shock & vibration absorber		Rubber sleeve(for fan motor)		
Insulation (noise & heat)		Polyurethane foam		
Operation control Operation switch		Remote control switch (Optional:RCD-HKX-S-E2)		
Room temperature control		Thermostat by electronics		
Safety equipment		Internal thermostat for fan motor. Frost protection thermostat		
Installation data Refrigerant piping size	mm(in)	Liquid line:φ9.52(3/8") Gas line:φ15.88(5/8")	Liquid line:φ9.52(3/8") Gas line:φ19.05(3/4")	
Connecting method		Flare piping		
Drain hose		Connectable with VP25		
Insulation for piping		Necessary (both Liquid & Gas lines)		
Accessories		Mounting kit		
Optional parts		Decorative Panel		
Outdoor units to be combined		FDCJ140HKXE2B,224HKXE2B,280HKXE2B,FDCP140HKXE2B,224HKXE2B,280HKXE2B		

Notes (1) The data are measured at the following conditions.

Item	Indoor air temperature		Outdoor air temperature		Standards
	DB	WB	DB	WB	
Cooling* ¹	27℃	19℃	35℃	24℃	ISO-T1,JIS B8616
Heating* ²	20℃	—	7℃	6℃	

(2) This packaged air-conditioner is manufactured and tested in conformity with the following standard.
JIS B8616"UNITARY AIR-CONDITIONERS"

●Decorative Panel model (Optional)

Item	Panel Part No.
Model FDTJ90,112,140 type	T-PSA-32W-E

(3) The number "2", following the type of each model, represents "CE-marked model" especially for European Union, and for European nations which require CE marking.

(b) 2-way outlet ceiling recessed type (FDTW)

Models FDTWJ28HKXE2B, 45HKXE2B, 56HKXE2B

Item	Models	FDTWJ28HKXE2B ⁽³⁾	FDTWJ45HKXE2B ⁽³⁾	FDTWJ56HKXE2B ⁽³⁾
		Nominal cooling capacity* ¹	W	2800
Nominal heating capacity* ²	W	3200	5000	6300
Power source		1 Phase 220/240V 50Hz		
Noise level	dB(A)	Hi: 39 Me:36 Lo: 33		
Exterior dimensions Height × Width × Depth	mm	Unit:280× 817× 620 Panel:8 × 1055 × 680		
Net weight	kg	Unit:19 Panel:7		
Refrigerant equipment Heat exchanger		Louver fins & inner grooved tubing		
Refrigerant control		Electronic Expansion Valve +Capillary tube		
Air handling equipment Fan type & Q'ty		Turbo fan × 1		
Motor	W	30 × 1		
Starting method		Line starting		
Air flow(Standard)	CMM	Hi: 14 Me: 12 Lo: 10		
Fresh air intake		Possible		
Air filter, Q'ty		Long life filter × 1(Washable)		
Shock & vibration absorber		Rubber sleeve(for fan motor)		
Insulation (noise & heat)		Polyurethane foam		
Operation control Operation switch		Remote control switch (Optional:RCD-HKX-S-E2)		
Room temperature control		Thermostat by electronics		
Safety equipment		Internal thermostat for fan motor. Frost protection thermostat		
Installation data Refrigerant piping size	mm(in)	Liquid line:φ 6.35(1/4") Gas line:φ 12.7(1/2")		Liquid line: φ 9.52(3/8") Gas line: φ 15.88(5/8")
Connecting method		Flare piping		
Drain hose		Connectable with VP25		
Insulation for piping		Necessary (both Liquid & Gas lines)		
Accessories		Mounting kit		
Optional parts		Decorative Panel		
Outdoor units to be combined		FDCJ140HKXE2B,224HKXE2B,280HKXE2B,FDCP140HKXE2B,224HKXE2B,280HKXE2B		

Notes (1) The data are measured at the following conditions.

Item	Indoor air temperature		Outdoor air temperature		Standards
	DB	WB	DB	WB	
Operation Cooling* ¹	27℃	19℃	35℃	24℃	ISO-T1,JIS B8616
Heating* ²	20℃	—	7℃	6℃	

(2) This packaged air-conditioner is manufactured and tested in conformity with the following standard.
JIS B8616"UNITARY AIR-CONDITIONERS"

●Decorative Panel model (Optional)

Item	Panel Part No.	
	Standard type	Attachment of ceiling material type
Model FDTWJ28,45,56 type	TW-PSA-22W-E	TW-PSB-28W-E

(3) The number "2", following the type of each model, represents"CE-marked model" especially for European Union, and for European nations which require CE marking.

Models FDTWJ71HKXE2B, 90HKXE2B

Item	Models	FDTWJ71HKXE2B ⁽³⁾	FDTWJ90HKXE2B ⁽³⁾
		Nominal cooling capacity* ¹	W
Nominal heating capacity* ²	W	8000	10000
Power source		1 Phase 220/240V 50Hz	
Noise level	dB(A)	Hi: 41 Me: 38 Lo: 35	Hi: 41 Me: 39 Lo: 36
Exterior dimensions Height × Width × Depth	mm	Unit:330 × 1054 × 620	Panel:8 × 1300 × 680
Net weight	kg	Unit:26	Panel:9
Refrigerant equipment Heat exchanger		Louver fins & inner grooved tubing	
Refrigerant control		Electronic Expansion Valve +Capillary tube	
Air handling equipment Fan type & Qty		Turbo fan × 1	
Motor	W	35 × 1	40 × 1
Starting method		Line starting	
Air flow(Standard)	CMM	Hi: 16 Me: 13 Lo: 11	Hi: 19 Me: 16 Lo: 12
Fresh air intake		Possible	
Air filter, Q'ty		Long life filter × 1(Washable)	
Shock & vibration absorber		Rubber sleeve(for fan motor)	
Insulation (noise & heat)		Polyurethane foam	
Operation control Operation switch		Remote control switch (Optional:RCD-HKX-S-E2)	
Room temperature control		Thermostat by electronics	
Safety equipment		Internal thermostat for fan motor. Frost protection thermostat	
Installation data Refrigerant piping size	mm(in)	Liquid line:φ9.52(3/8"),Gas line:φ15.88(5/8")	
Connecting method		Flare piping	
Drain hose		Connectable with VP25	
Insulation for piping		Necessary (both Liquid & Gas lines)	
Accessories		Mounting kit	
Optional parts		Decorative Panel	
Outdoor units to be combined		FDCJ140HKXE2B,224HKXE2B,280HKXE2B,FDCP140HKXE2B,224HKXE2B,280HKXE2B	

Notes (1) The data are measured at the following conditions.

Item	Indoor air temperature		Outdoor air temperature		Standards
	DB	WB	DB	WB	
Operation Cooling* ¹	27℃	19℃	35℃	24℃	ISO-T1,JIS B8616
Heating* ²	20℃	—	7℃	6℃	

(2) This packaged air-conditioner is manufactured and tested in conformity with the following standard.
JIS B8616"UNITARY AIR-CONDITIONERS"

●Decorative Panel model (Optional)

Item	Panel Part No.	
	Standard type	Attachment of ceiling material type
Model FDTWJ71,90 type	TW-PSA-32W-E	TW-PSB-38W-E

(3) The number "2", following the type of each model, represents"CE-marked model" especially for European Union, and for European nations which require CE marking.

Models FDTWJ112HKXE2B, 140HKXE2B

Item		Models	FDTWJ112HKXE2B ⁽³⁾	FDTWJ140HKXE2B ⁽³⁾
Nominal cooling capacity* ¹	W		11200	14000
Nominal heating capacity* ²	W		12500	16000
Power source			1 Phase 220/240V 50Hz	
Noise level	dB(A)		Hi: 44 Me: 41 Lo: 38	Hi: 45 Me: 42 Lo: 39
Exterior dimensions Height × Width × Depth	mm		Unit:345 × 1524 × 620	Panel:8 × 1770 × 680
Net weight	kg		Unit:38	Panel:11
Refrigerant equipment Heat exchanger			Louver fins & inner grooved tubing	
Refrigerant control			Electronic Expansion Valve +Capillary tube	
Air handling equipment Fan type & Qty			Turbo fan × 2	
Motor	W		40 × 2	50 × 2
Starting method			Line starting	
Air flow(Standard)	CMM		Hi: 28 Me: 25 Lo: 23	Hi: 32 Me: 28 Lo: 24
Fresh air intake			Possible	
Air filter, Qty			Long life filter × 2(Washable)	
Shock & vibration absorber			Rubber sleeve(for fan motor)	
Insulation (noise & heat)			Polyurethane foam	
Operation control Operation switch			Remote control switch (Optional:RCD-HKX-S-E2)	
Room temperature control			Thermostat by electronics	
Safety equipment			Internal thermostat for fan motor. Frost protection thermostat	
Installation data Refrigerant piping size	mm(in)		Liquid line:φ 9.52(3/8"), Gas line:φ 19.05(3/4")	
Connecting method			Flare piping	
Drain hose			Connectable with VP25	
Insulation for piping			Necessary (both Liquid & Gas linse)	
Accessories			Mounting kit	
Optional parts			Decorative Panel	
Outdoor units to be combined			FDCJ140HKXE2B,224HKXE2B,280HKXE2B,FDCP140HKXE2B,224HKXE2B,280HKXE2B	

Notes (1) The data are measured at the following conditions.

Item	Indoor air temperature		Outdoor air temperature		Standards
	DB	WB	DB	WB	
Cooling* ¹	27℃	19℃	35℃	24℃	ISO-T1,JIS B8616
Heating* ²	20℃	—	7℃	6℃	

(2) This packaged air-conditioner is manufactured and tested in conformity with the following standard.
JIS B8616"UNITARY AIR-CONDITIONERS"

●Decorative Panel model (Optional)

Item	Panel Part No.	
	Standard type	Attachment of ceiling material type
FDTWJ112,140 type	TW-PSA-42W-E	TW-PSB-48W-E

(3) The number "2", following the type of each model, represents "CE-marked model" especially for European Union, and for European nations which require CE marking.

(c) 1-way outlet ceiling recessed type (FDTS)

Models FDTSJ22HKXE2B, 28HKXE2B, 36HKXE2B

Item	Model	FDTSJ22HKXE2B ⁽³⁾		FDTSJ28HKXE2B ⁽³⁾		FDTSJ36HKXE2B ⁽³⁾	
Nominal cooling capacity* ¹	W	2200		2800		3600	
Nominal heating capacity* ²	W	2500		3200		4000	
Power source		1 Phase 220/240V 50Hz					
Noise level	dB(A)	Hi: 39 Lo: 38		Hi: 40 Me: 39 Lo: 38			
Exterior dimensions Height × Width × Depth	mm	Unit:194 × 1040 × 650 Panel:10 × 1290 × 770					
Net weight	Kg	Unit:26 Panel:6					
Refrigerant equipment Heat exchanger		Louver fine & inner grooved tubing					
Refrigerant control		Electronic Expansion Valve +Capillary tube					
Air handling equipment Fan type & Q'ty		Centrifugal fan × 2					
Motor	W	35 × 1					
Starting method		Line starting					
Air flow(Standard)	CMM	Hi: 11 Lo: 8		Hi: 12 Me: 11 Lo: 10			
Fresh air intake		Possible					
Air filter, Q'ty		Long life filter × 1(Washable)					
Shock & vibration absorber		Rubber sleeve(for fan motor)					
Insulation (noise & heat)		Polyurethane foam					
Operation control Operation switch		Remote control switch (Optional:RCD-HKX-S-E2)					
Room temperature control		Thermostat by electronics					
Safety equipment		Internal thermostat for fan motor. Frost protection thermostat					
Installation data Refrigerant piping size	mm(in)	Liquid line:φ6.35(1/4"),Gas line:φ12.7(1/2")					
Connecting method		Flare piping					
Drain hose		Connectable with VP25					
Insulation for piping		Necessary (both Liquid & Gas lines)					
Accessories		Mounting kit					
Optional parts		Decorative Panel					
Outdoor units to be combined		FDCJ140HKXE2B,224HKXE2B,280HKXE2B,FDCP140HKXE2B,224HKXE2B,280HKXE2B					

Notes (1) The data are measured at the following conditions.

Item	Indoor air temperature		Outdoor air temperature		Standards
	DB	WB	DB	WB	
Operation					
Cooling* ¹	27℃	19℃	35℃	24℃	ISO-T1,JIS B8616
Heating* ²	20℃	—	7℃	6℃	

(2) This packaged air-conditioner is manufactured and tested in conformity with the following standard.
JIS B8616"UNITARY AIR-CONDITIONERS"

●Decorative Panel model (Optional)

Model	Item	Panel Part No.
		FDTSJ22,28,36 type

(3) The number "2", following the type of each model, represents"CE-marked model" especially for European Union, and for European nations which require CE marking.

Models FDTSJ45HKXE2B, 71HKXE2B

Item		Model	FDTSJ45HKXE2B ⁽³⁾	FDTSJ71HKXE2B ⁽³⁾
Nominal cooling capacity* ¹	W		4500	7100
Nominal heating capacity* ²	W		5000	8000
Power source			1 Phase 220/240V 50Hz	
Noise level	dB(A)		Hi: 43 Me: 40 Lo: 38	Hi: 44 Me: 40 Lo: 38
Exterior dimensions Height × Width × Depth	mm		Unit:194 × 1040 × 650 Panel:10 × 1290 × 770	Unit:194 × 1300 × 650 Panel:10 × 1500 × 790
Net weight	kg		Unit:26 Panel:6	Unit:30 Panel:7
Refrigerant equipment Heat exchanger			Louver fins & inner grooved tubing	
Refrigerant control			Electronic Expansion Valve +Capillary tube	
Air handling equipment Fan type & Qty			Centrifugal fan × 2	Centrifugal fan × 4
Motor	W		40 × 1	25 × 2
Starting method			Line starting	
Air flow(Standard)	CMM		Hi: 14 Me: 12 Lo: 10	Hi: 18 Me: 15 Lo: 12
Fresh air intake			Possible	
Air filter, Qty			Long life filter × 1(Washable)	
Shock & vibration absorber			Rubber sleeve(for fan motor)	
Insulation (noise & heat)			Polyurethane foam	
Operation control Operation switch			Remote control switch (Optional:RCD-HKX-S-E2)	
Room temperature control			Thermostat by electronics	
Safety equipment			Internal thermostat for fan motor. Frost protection thermostat	
Installation data Refrigerant piping size	mm(in)		Liquid line:φ 6.35(1/4") Gas line:φ 12.7(1/2")	Liquid line:φ 9.52(3/8") Gas line:φ 15.88(5/8")
Connecting method			Flare piping	
Drain hose			Connectable with VP25	
Insulation for piping			Necessary (both Liquid & Gas lines)	
Accessories			Mounting kit	
Optional parts			Decorative Panel	
Outdoor units to be combined			FDCJ140HKXE2B, 224HKXE2B, 280HKXE2B,FDCP140HKXE2B,224HKXE2B,280HKXE2B	

Notes (1) The data are measured at the following conditions.

Item	Indoor air temperature		Outdoor air temperature		Standards
	DB	WB	DB	WB	
Cooling* ¹	27℃	19℃	35℃	24℃	ISO-T1,JIS B8616
Heating* ²	20℃	—	7℃	6℃	

(2) This packaged air-conditioner is manufactured and tested in conformity with the following standard.
JIS B8616"UNITARY AIR-CONDITIONERS"

●Decorative Panel model (Optional)

Item	Panel Part No.
Model	With Auto Swing
FDTSJ45 type	TS-PSA-26W-E
FDTSJ71 type	TS-PSA-36W-E

(3) The number "2", following the type of each model, represents "CE-marked model" especially for European Union, and for European nations which require CE marking.

(d) Cassetteria type (FDR)

Models FDRJ22HKXE2, 28HKXE2

Item	Models	FDRJ22HKXE2 ⁽⁴⁾		FDRJ28HKXE2 ⁽⁴⁾	
		Silent panel	Canvas panel	Silent panel	Canvas panel
Air inlet panel		R-PNLS-26W-E	R-PNLC-26W-E	R-PNLS-26W-E	R-PNLC-26W-E
Panel model (Option)					
Nominal cooling capacity ^{*1}	W	2200		2800	
Nominal heating capacity ^{*2}	W	2500		3200	
Power source		1 Phase 220/240V 50Hz			
Noise level	dB(A)	Hi: 41 Me: 39 Lo: 36	Hi: 42 Me: 40 Lo: 37	Hi: 42 Me: 40 Lo: 37	Hi: 43 Me: 41 Lo: 38
Exterior dimensions Height × Width × Depth	mm	Unit:355 × 750 × 635 Panel:10 × 1040 × 750	Unit:355 × 750 × 635 Panel:10 × 864 × 585	Unit:355 × 750 × 635 Panel:10 × 1040 × 750	Unit:355 × 750 × 635 Panel:10 × 864 × 585
Net weight	kg	Unit:30 Panel:7	Unit:30 Panel:5	Unit:30 Panel:7	Unit:30 Panel:5
Refrigerant equipment Heat exchanger		Louver fins & inner grooved tubing			
Refrigerant control		Electronic Expansion Valve +Capillary tube			
Air handling equipment Fan type & Qty		Centrifugal fan × 2			
Motor	W	40 × 1		50 × 1	
Starting method		Line starting			
Air flow(Standard)	CMM	Hi: 10 Me: 9 Lo: 8		Hi: 12 Me: 11 Lo: 10	
Available static pressure (at Me)	Pa (mmAq)	Standard:45 (4.5), Hi speed:85 (8.5)			
Fresh air intake		Side or back			
Air filter Q'ty		Long life filter × 1(Washable)			
Shock & vibration absorber		Rubber sleeve(for fan motor)			
Insulation (noise & heat)		Polyurethane foam			
Operation control Operation switch		Remote control switch (Optional:RCD-HKX-E2)			
Room temperature control		Thermostat by electronics			
Safety equipment		Internal thermostat for fan motor. Frost protection thermostat			
Installation data Refrigerant piping size	mm(in)	Liquid line:φ6.35(1/4"),Gas line:φ12.7(1/2")			
Connecting method		Flare piping			
Drain hose		Connectable with VP25			
Insulation for piping		Necessary (both Liquid & Gas lines)			
Accessories		Mounting kit			
Optional parts		Silent panel, Canvas panel, Canvas duct			
Outdoor units to be combined		FDCJ140HKXE2B,224HKXE2B,280HKXE2B,FDCP140HKXE2B,224HKXE2B,280HKXE2B			

Notes (1)The data are measured at the following conditions.

Item	Indoor air temperature		Outdoor air temperature		Standards
	DB	WB	DB	WB	
Operation					
Cooling ^{*1}	27℃	19℃	35℃	24℃	ISO-T1,JIS B8616
Heating ^{*2}	20℃	—	7℃	6℃	

(2)This packaged air-conditioner is manufactured and tested in conformity with the following standard.
JIS B8616"UNITARY AIR-CONDITIONERS"

(3)Canvas panel is used in combination with following canvas duct
Canvas duct: HA01503

(4)The number "2",following the type of each model,represents"CE-marked model"especially for European Union, and for European nations which require CE marking.

(5)Add the canvas duct length to the unit height for the canvas type.

Models FDRJ45HKXE2, 56HKXE2

Item		Models	FDRJ45HKXE2 ⁽⁴⁾		FDRJ56HKXE2 ⁽⁴⁾	
Air inlet panel			Silent panel	Canvas panel	Silent panel	Canvas panel
Panel model (Option)			R-PNLS-26W-E	R-PNLC-26W-E	R-PNLS-26W-E	R-PNLC-26W-E
Nominal cooling capacity ^{*1}	W		4500		5600	
Nominal heating capacity ^{*2}	W		5000		6300	
Power source			1 Phase 220/240V 50Hz			
Noise level	dB(A)		Hi: 43 Me: 40 Lo: 37	Hi: 44 Me: 41 Lo: 38	Hi:43 Me: 40 Lo: 37	Hi: 44 Me: 41 Lo: 38
Exterior dimensions Height × Width × Depth	mm		Unit:355 × 750 × 635 Panel:10 × 1040 × 750	Unit:355 × 750 × 635 Panel:10 × 864 × 585	Unit:355 × 750 × 635 Panel:10 × 1040 × 750	Unit:355 × 750 × 635 Panel:10 × 864 × 585
Net weight	kg		Unit:30 Panel:7	Unit:30 Panel:5	Unit:30 Panel:7	Unit:30 Panel:5
Refrigerant equipment Heat exchanger			Louver fins & inner grooved tubing			
Refrigerant control			Electronic Expansion Valve +Capillary tube			
Air handling equipment Fan type & Q'ty			Centrifugal fan × 2			
Motor	W		55 × 1			
Starting method			Line starting			
Air flow(Standard)	CMM		Hi: 14 Me: 12 Lo: 11			
Available static pressure (at Me)	Pa (mmAq)		Standard:50 (5.0), Hi speed:85 (8.5)			
Fresh air intake			Side or back			
Air filter Q'ty			Long life filter × 1(Washable)			
Shock & vibration absorber			Rubber sleeve(for fan motor)			
Insulation (noise & heat)			Polyurethane foam			
Operation control Operation switch			Remote control switch (Optional:RCD-HKX-E2)			
Room temperature control			Thermostat by electronics			
Safety equipment			Internal thermostat for fan motor. Frost protection thermostat			
Installation data Refrigerant piping size	mm(in)		Liquid line:φ 6.35(1/4") Gas line:φ 12.7(1/2")		Liquid line:φ 9.52(3/8") Gas line:φ 15.88(5/8")	
Connecting method			Flare piping			
Drain hose			Connectable with VP25			
Insulation for piping			Necessary (both Liquid & Gas lines)			
Accessories			Mounting kit			
Optional parts			Silent panel, Canvas panel, Canvas duct			
Outdoor units to be combined			FDCJ140HKXE2B,224HKXE2B,280HKXE2B,FDCP140HKXE2B,224HKXE2B,280HKXE2B			

Notes (1)The data are measured at the following conditions.

Item	Indoor air temperature		Outdoor air temperature		Standards
	DB	WB	DB	WB	
Operation					
Cooling ^{*1}	27℃	19℃	35℃	24℃	ISO-T1,JIS B8616
Heating ^{*2}	20℃	—	7℃	6℃	

(2)This packaged air-conditioner is manufactured and tested in conformity with the following standard.
JIS B8616"UNITARY AIR-CONDITIONERS"

(3)Canvas panel is used in combination with following canvas duct
Canvas duct: HA01503

(4)The number "2",following the type of each model,represents"CE-marked model"especially for European Union, and for European nations which require CE marking.

(5)Add the canvas duct length to the unit height for the canvas type.

Models FDRJ71HKXE2, 90HKXE2

Item		Models	FDRJ71HKXE2 ⁽⁴⁾		FDRJ90HKXE2 ⁽⁴⁾	
Air inlet panel			Silent panel	Canvas panel	Silent panel	Canvas panel
Panel model (Option)			R-PNLS-36W-E	R-PNLC-36W-E	R-PNLS-36W-E	R-PNLC-36W-E
Nominal cooling capacity ^{*1}	W		7100		9000	
Nominal heating capacity ^{*2}	W		8000		10000	
Power source			1 Phase 220/240V 50Hz			
Noise level	dB(A)		Hi: 43 Me: 40 Lo: 37	Hi: 44 Me: 41 Lo: 38	Hi: 43 Me: 40 Lo: 37	Hi: 44 Me: 41 Lo: 38
Exterior dimensions Height × Width × Depth	mm		Unit:355 × 950 × 635 Panel:10 × 1240 × 750	Unit:355 × 950 × 635 Panel:10 × 1064 × 585	Unit:355 × 950 × 635 Panel:10 × 1240 × 750	Unit:355 × 950 × 635 Panel:10 × 1064 × 585
Net weight	kg		Unit:35 Panel:8	Unit:35 Panel:6	Unit:35 Panel:8	Unit:35 Panel:6
Refrigerant equipment Heat exchanger			Louver fins & inner grooved tubing			
Refrigerant control			Electronic Expansion Valve +Capillary tube			
Air handling equipment Fan type & Q'ty			Centrifugal fan × 2			
Motor	W		90 × 1		100 × 1	
Starting method			Line starting			
Air flow(Standard)	CMM		Hi: 18 Me: 16 Lo: 14		Hi: 20 Me: 18 Lo: 15	
Available static pressure (at Me)	Pa (mmAp)		Standard:45 (4.5), Hi speed:80 (8.0)			
Fresh air intake			Side or back			
Air filter Q'ty			Long life filter × 1(Washable)			
Shock & vibration absorber			Rubber sleeve(for fan motor)			
Insulation (noise & heat)			Polyurethane foam			
Operation control Operation switch			Remote control switch (Optional:RCD-HKX-E2)			
Room temperature control			Thermostat by electronics			
Safety equipment			Internal thermostat for fan motor. Frost protection thermostat			
Installation data Refrigerant piping size	mm(in)		Liquid line:φ 9.52(3/8"),Gas line:φ 15.88(5/8")			
Connecting method			Flare piping			
Drain hose			Connectable with VP25			
Insulation for piping			Necessary (both Liquid & Gas lines)			
Accessories			Mounting kit			
Optional parts			Silent panel, Canvas panel, Canvas duct			
Outdoor units to be combined			FDCJ140HKXE2B,224HKXE2B,280HKXE2B,FDCP140HKXE2B,224HKXE2B,280HKXE2B			

Notes (1)The data are measured at the following conditions.

Item	Indoor air temperature		Outdoor air temperature		Standards
	DB	WB	DB	WB	
Cooling ^{*1}	27℃	19℃	35℃	24℃	ISO-T1,JIS B8616
Heating ^{*2}	20℃	—	7℃	6℃	

(2)This packaged air-conditioner is manufactured and tested in conformity with the following standard.
JIS B8616"UNITARY AIR-CONDITIONERS"

(3)Canvas panel is used in combination with following canvas duct
Canvas duct: HA01490

(4)The number "2",following the type of each model,represents"CE-marked model"especially for European Union, and for European nations which require CE marking.

(5)Add the canvas duct length to the unit height for the canvas type.

Models FDRJ112HKXE2, 140HKXE2

Item		Models		FDRJ112HKXE2 ⁽⁴⁾		FDRJ140HKXE2 ⁽⁴⁾	
				Silent panel	Canvas panel	Silent panel	Canvas panel
Air inlet panel				Silent panel	Canvas panel	Silent panel	Canvas panel
Panel model (Option)				R-PNLS-46W-E	R-PNLC-46W-E	R-PNLS-46W-E	R-PNLC-46W-E
Nominal cooling capacity ^{*1}		W	11200			14000	
Nominal heating capacity ^{*2}		W	12500			16000	
Power source		1 Phase 220/240V 50Hz					
Noise level		dB(A)	Hi: 45 Me: 42 Lo: 38	Hi: 46 Me: 43 Lo: 39	Hi: 46 Me: 43 Lo: 39	Hi: 47 Me: 44 Lo: 40	
Exterior dimensions Height × Width × Depth		mm	Unit:406 × 1370 × 635 Panel:10 × 1660 × 750	Unit:406 × 1370 × 635 Panel:10 × 1484 × 585	Unit:406 × 1370 × 635 Panel:10 × 1660 × 750	Unit:406 × 1370 × 635 Panel:10 × 1484 × 585	
Net weight		kg	Unit:50 Panel:9	Unit:50 Panel:7	Unit:52 Panel:9	Unit:52 Panel:7	
Refrigerant equipment Heat exchanger		Louver fins & inner grooved tubing					
Refrigerant control		Electronic Expansion Valve +Capillary tube					
Air handling equipment Fan type & Q'ty		Centrifugal fan × 3					
Motor		W	45 × 1, 90 × 1			50 × 1, 100 × 1	
Starting method		Line starting					
Air flow(Standard)		CMM	Hi: 28 Me: 25 Lo: 22			Hi: 34 Me: 31 Lo: 27	
Available static pressure (at Me)		Pa (mmAq)	Standard:50 (5.0), Hi speed:80 (8.0)				
Fresh air intake		Side or back					
Air filter Q'ty		Long life filter × 2(Washable)					
Shock & vibration absorber		Rubber sleeve(for fan motor)					
Insulation (noise & heat)		Polyurethane foam					
Operation control Operation switch		Remote control switch (Optional:RCD-HKX-E2)					
Room temperature control		Thermostat by electronics					
Safety equipment		Internal thermostat for fan motor. Frost protection thermostat					
Installation data Refrigerant piping size		mm(in)	Liquid line:φ 9.52(3/8"),Gas line:φ 19.05(3/4")				
Connecting method		Flare piping					
Drain hose		Connectable with VP25					
Insulation for piping		Necessary (both Liquid & Gas lines)					
Accessories		Mounting kit					
Optional parts		Silent panel, Canvas panel, Canvas duct					
Outdoor units to be combined		FDCJ140HKXE2B,224HKXE2B,280HKXE2B,FDCP140HKXE2B,224HKXE2B,280HKXE2B					

Notes (1)The data are measured at the following conditions.

Item	Indoor air temperature		Outdoor air temperature		Standards
	DB	WB	DB	WB	
Operation					
Cooling ^{*1}	27℃	19℃	35℃	24℃	ISO-T1,JIS B8616
Heating ^{*2}	20℃	—	7℃	6℃	

(2)This packaged air-conditioner is manufactured and tested in conformity with the following standard.
JIS B8616"UNITARY AIR-CONDITIONERS"

(3)Canvas panel is used in combination with following canvas duct
Canvas duct: HA01484

(4)The number "2",following the type of each model,represents"CE-marked model"especially for European Union, and for European nations which require CE marking.

(5)Add the canvas duct length to the unit height for the canvas type.

(e) Satellite ducted type (FDUM)

Models FDUMJ36HKXE2, 45HKXE2

Item	Models	FDUMJ36HKXE2 ⁽²⁾		FDUMJ45HKXE2 ⁽³⁾	
Nominal cooling capacity* ¹	W	3600		4500	
Nominal heating capacity* ²	W	4000		5000	
Power source		1 Phase 220/240V 50Hz			
Noise level	dB(A)	Hi: 34 Me: 32 Lo: 29		Hi: 35 Me: 32 Lo: 29	
Exterior dimensions Height × Width × Depth	mm	299 × 750 × 635			
Net weight	kg	34			
Refrigerant equipment Heat exchanger		Louver fins & inner grooved tubing			
Refrigerant control		Electronic Expansion Valve +Capillary tube			
Air handling equipment Fan type & Q'ty		Centrifugal fan × 2			
Motor	W	50 × 1		55 × 1	
Starting method		Line starting			
Air flow(Standard)	CMM	Hi: 12 Me: 11 Lo: 10		Hi: 14 Me: 12 Lo: 11	
Available static pressure (at Me)	Pa (mmAq)	Standard:50 (5.0), Hi speed:85 (8.5)			
Fresh air intake		Side			
Air filter, Q'ty		-			
Shock & vibration absorber		Rubber sleeve(for fan motor)			
Insulation (noise & heat)		Polyurethane foam			
Operation control Operation switch		Remote control switch (Optional:RCD-HKX-E2)			
Room temperature control		Thermostat by electronics			
Safety equipment		Internal thermostat for fan motor. Frost protection thermostat			
Installation data Refrigerant piping size	mm(in)	Liquid line:φ6.35(1/4"),Gas line:φ12.7(1/2")			
Connecting method		Flare piping			
Drain hose		Connectable with VP25			
Insulation for piping		Necessary (both Liquid & Gas lines)			
Accessories		Mounting kit			
Optional parts		-			
Outdoor units to be combined		FDCJ140HKXE2B,224HKXE2B,280HKXE2B,FDCP140HKXE2B,224HKXE2B,280HKXE2B			

Notes (1) The data are measured at the following conditions.

Item	Indoor air temperature		Outdoor air temperature		Standards
	DB	WB	DB	WB	
Operation Cooling* ¹	27℃	19℃	35℃	24℃	ISO-T1,JIS B8616
Heating* ²	20℃	—	7℃	6℃	

(2) This packaged air-conditioner is manufactured and tested in conformity with the following standard.
JIS B8616"UNITARY AIR-CONDITIONERS"

(3) The number "2", following the type of each model, represents"CE-marked model" especially for European Union, and for European nations which require CE marking.

Models FDUMJ56HKXE2, 71HKXE2, 90HKXE2

Item	Models		FDUMJ56HKXE2 ⁽³⁾	FDUMJ71HKXE2 ⁽³⁾	FDUMJ90HKXE2 ⁽³⁾
	Nominal cooling capacity ^{*1}	W	5600	7100	9000
Nominal heating capacity ^{*2}	W	6300	8000	10000	
Power source		1 Phase 220/240V 50Hz			
Noise level	dB(A)	Hi: 35 Me: 32 Lo: 29	Hi: 35 Me: 32 Lo: 29	Hi: 36 Me: 33 Lo: 30	
Exterior dimensions Height × Width × Depth	mm	299 × 750 × 635	299 × 950 × 635		
Net weight	kg	34	40		
Refrigerant equipment Heat exchanger		Louver fins & inner grooved tubing			
Refrigerant control		Electronic Expansion Valve +Capillary tube			
Air handling equipment Fan type & Qty		Centrifugal fan × 2			
Motor	W	55 × 1	90 × 1	100 × 1	
Starting method		Line starting			
Air flow(Standard)	CMM	Hi: 14 Me: 12 Lo: 11	Hi: 18 Me: 16 Lo: 14	Hi: 20 Me: 18 Lo: 15	
Available static pressure (at Me)	Pa (mmAq)	Standard:50 (5.0), Hi speed:85 (8.5)			
Fresh air intake		Side			
Air filter, Q'ty		-			
Shock & vibration absorber		Rubber sleeve(for fan motor)			
Insulation (noise & heat)		Polyurethane foam			
Operation control Operation switch		Remote control switch (Optional:RCD-HKX-E2)			
Room temperature control		Thermostat by electronics			
Safety equipment		Internal thermostat for fan motor. Frost protection thermostat			
Installation data Refrigerant piping size	mm(in)	Liquid line:φ 9.52(3/8"), Gas line:φ 15.88(5/8")			
Connecting method		Flare piping			
Drain hose		Connectable with VP25			
Insulation for piping		Necessary (both Liquid & Gas lines)			
Accessories		Mounting kit			
Optional parts		-			
Outdoor units to be combined		FDCJ140HKXE2B,224HKXE2B,280HKXE2B,FDCP140HKXE2B,224HKXE2B,280HKXE2B			

Notes (1) The data are measured at the following conditions.

Item	Indoor air temperature		Outdoor air temperature		Standards
	DB	WB	DB	WB	
Operation					
Cooling ^{*1}	27℃	19℃	35℃	24℃	ISO-T1,JIS B8616
Heating ^{*2}	20℃	—	7℃	6℃	

(2) This packaged air-conditioner is manufactured and tested in conformity with the following standard.
JIS B8616"UNITARY AIR-CONDITIONERS"

(3) The number "2", following the type of each model, represents"CE-marked model" especially for European Union, and for European nations which require CE marking.

Models FDUMJ112HKXE2, 140HKXE2

Item	Models		FDUMJ112HKXE2 ⁽³⁾	FDUMJ140HKXE2 ⁽³⁾
	Nominal cooling capacity* ¹	W		11200
Nominal heating capacity* ²	W		12500	16000
Power source			1 Phase 220/240V 50Hz	
Noise level	dB(A)		Hi: 38 Me: 35 Lo: 32	Hi: 39 Me: 37 Lo: 34
Exterior dimensions Height × Width × Depth	mm		350 × 1370 × 635	
Net weight	kg		57	59
Refrigerant equipment Heat exchanger			Louver fins & inner grooved tubing	
Refrigerant control			Electronic Expansion Valve +Capillary tube	
Air handling equipment Fan type & Qty			Centrifugal fan × 3	
Motor	W		45 × 1, 90 × 1	50 × 1, 100 × 1
Starting method			Line starting	
Air flow(Standard)	CMM		Hi: 28 Me: 25 Lo: 22	Hi: 34 Me: 31 Lo: 27
Available static pressure (at Me)	Pa (mmAq)		Standard:60 (6.0), Hi speed:90 (9.0)	Standard:60 (6.0), Hi speed:85 (8.5)
Fresh air intake			Side	
Air filter, Q'ty			-	
Shock & vibration absorber			Rubber sleeve(for fan motor)	
Insulation (noise & heat)			Polyurethane foam	
Operation control Operation switch			Remote control switch (Optional:RCD-HKX-E2)	
Room temperature control			Thermostat by electronics	
Safety equipment			Internal thermostat for fan motor. Frost protection thermostat	
Installation data Refrigerant piping size	mm(in)		Liquid line:φ9.52(3/8"),Gas line:φ19.05(3/4")	
Connecting method			Flare piping	
Drain hose			Connectable with VP25	
Insulation for piping			Necessary (both Liquid & Gas lines)	
Accessories			Mounting kit	
Optional parts			-	
Outdoor units to be combined			FDCJ140HKXE2B,224HKXE2B,280HKXE2B,FDCP140HKXE2B,224HKXE2B,280HKXE2B	

Notes (1) The data are measured at the following conditions.

Item	Indoor air temperature		Outdoor air temperature		Standards
	DB	WB	DB	WB	
Operation					
Cooling* ¹	27℃	19℃	35℃	24℃	ISO-T1,JIS B8616
Heating* ²	20℃	—	7℃	6℃	

(2) This packaged air-conditioner is manufactured and tested in conformity with the following standard.
JIS B8616"UNITARY AIR-CONDITIONERS"

(3) The number "2", following the type of each model, represents"CE-marked model" especially for European Union, and for European nations which require CE marking.

(f) Ceiling suspension type (FDE)

Models FDEJ36HKXE2B, 45HKXE2B

Item	Models	FDEJ36HKXE2B ⁽³⁾	FDEJ45HKXE2B ⁽³⁾
		Nominal cooling capacity* ¹	W
Nominal heating capacity* ²	W	4000	5000
Power source		1 Phase 220/240V 50Hz	
Noise level	dB(A)	Hi: 43 Me:40 Lo: 38	
Exterior dimensions Height × Width × Depth	mm	184 × 1000 × 650	
Net weight	kg	22	
Refrigerant equipment Heat exchanger		Louver fins & inner grooved tubing	
Refrigerant control		Electronic Expansion Valve + Capillary tube	
Air handling equipment Fan type & Q'ty		Centrifugal fan × 2	
Motor	W	40 × 1	
Starting method		Line starting	
Air flow(Standard)	CMM	Hi: 14 Me: 12 Lo: 10	
Fresh air intake		Not possible	
Air filter, Q'ty		Polypropylene net × 2(Washable)	
Shock & vibration absorber		Rubber sleeve(for fan motor)	
Insulation (noise & heat)		Polyurethane foam	
Operation control Operation switch		Remote control switch (Optional:RCD-HKX-S-E2)	
Room temperature control		Thermostat by electronics	
Safety equipment		Internal thermostat for fan motor. Frost protection thermostat	
Installation data Refrigerant piping size	mm(in)	Liquid line:φ 6.35(1/4"), Gas line:φ 12.7(1/2")	
Connecting method		Flare piping	
Drain hose		Connectable with VP20	
Insulation for piping		Necessary (both Liquid & Gas lines)	
Accessories		Mounting kit	
Optional parts		-	
Outdoor units to be combined		FDCJ140HKXE2B,224HKXE2B,280HKXE2B,FDCP140HKXE2B,224HKXE2B,280HKXE2B	

Notes (1) The data are measured at the following conditions.

Item	Indoor air temperature		Outdoor air temperature		Standards
	DB	WB	DB	WB	
Operation					
Cooling* ¹	27℃	19℃	35℃	24℃	ISO-T1,JIS B8616
Heating* ²	20℃	—	7℃	6℃	

(2) This packaged air-conditioner is manufactured and tested in conformity with the following standard.
JIS B8616"UNITARY AIR-CONDITIONERS"

(3) The number "2", following the type of each model, represents"CE-marked model" especially for European Union, and for European nations which require CE marking.

Models FDEJ56HKXE2B, 71HKXE2B

	Models	FDEJ56HKXE2B ⁽³⁾	FDEJ71HKXE2B ⁽³⁾
Nominal cooling capacity* ¹	W	5600	7100
Nominal heating capacity* ²	W	6300	8000
Power source		1 Phase 220/240V 50Hz	
Noise level	dB(A)	Hi: 43 Me:40 Lo: 38	Hi: 44 Me:40 Lo: 38
Exterior dimensions Height × Width × Depth	mm	184 × 1000 × 650	184 × 1260 × 650
Net weight	kg	22	27
Refrigerant equipment Heat exchanger		Louver fins & inner grooved tubing	
Refrigerant control		Electronic Expansion Valve + Capillary tube	
Air handling equipment Fan type & Q'ty		Centrifugal fan × 2	Centrifugal fan × 4
Motor	W	40 × 1	25 × 2
Starting method		Line starting	
Air flow(Standard)	CMM	Hi: 14 Me: 12 Lo: 10	Hi: 18 Me: 15 Lo: 12
Fresh air intake		Not possible	
Air filter, Q'ty		Polypropylene net × 2(Washable)	
Shock & vibration absorber		Rubber sleeve(for fan motor)	
Insulation (noise & heat)		Polyurethane foam	
Operation control Operation switch		Remote control switch (Optional:RCD-HKX-S-E2)	
Room temperature control		Thermostat by electronics	
Safety equipment		Internal thermostat for fan motor. Frost protection thermostat	
Installation data Refrigerant piping size	mm(in)	Liquid line: φ9.52(3/8"), Gas line: φ15.88(5/8")	
Connecting method		Flare piping	
Drain hose		Connectable with VP20	
Insulation for piping		Necessary (both Liquid & Gas lines)	
Accessories		Mounting kit	
Optional parts		-	
Outdoor units to be combined		FDCJ140HKXE2B,224HKXE2B,280HKXE2B,FDPC140HKXE2B,224HKXE2B,280HKXE2B	

Notes (1) The data are measured at the following conditions.

Item	Indoor air temperature		Outdoor air temperature		Standards
	DB	WB	DB	WB	
Operation					
Cooling* ¹	27℃	19℃	35℃	24℃	ISO-T1,JIS B8616
Heating* ²	20℃	—	7℃	6℃	

(2) This packaged air-conditioner is manufactured and tested in conformity with the following standard.

JIS B8616"UNITARY AIR-CONDITIONERS"

(3) The number "2", following the type of each model, represents"CE-marked model" especially for European Union, and for European nations which require CE marking.

Models FDEJ112HKXE2B, 140HKXE2B

Item		Models	FDEJ112HKXE2B ⁽³⁾	FDEJ140HKXE2B ⁽³⁾
Nominal cooling capacity* ¹		W	11200	14000
Nominal heating capacity* ²		W	12500	16000
Power source			1 Phase 220/240V 50Hz	
Noise level		dB(A)	Hi: 49 Me:46 Lo: 42	Hi: 50 Me:47 Lo: 42
Exterior dimensions Height × Width × Depth		mm	239 × 1260 × 650	239 × 1470 × 650
Net weight		kg	34	40
Refrigerant equipment Heat exchanger			Louver fins & inner grooved tubing	
Refrigerant control			Electronic Expansion Valve +Capillary tube	
Air handling equipment Fan type & Qty			Centrifugal fan × 3	Centrifugal fan × 4
Motor		W	35 × 1 + 55 × 1	55 × 2
Starting method			Line starting	
Air flow(Standard)		CMM	Hi: 28 Me: 25 Lo: 22	Hi: 34 Me: 30 Lo: 26
Fresh air intake			Not possible	
Air filter, Q'ty			Polypropylene net × 2(Washable)	
Shock & vibration absorber			Rubber sleeve(for fan motor)	
Insulation (noise & heat)			Polyurethane foam	
Operation control Operation switch			Remote control switch (Optional:RCD-HKX-S-E2)	
Room temperature control			Thermostat by electronics	
Safety equipment			Internal thermostat for fan motor. Frost protection thermostat	
Installation data Refrigerant piping size		mm(in)	Liquid line: φ9.52(3/8"), Gas line: φ19.05(3/4")	
Connecting method			Flare piping	
Drain hose			Connectable with VP20	
Insulation for piping			Necessary (both Liquid & Gas lines)	
Accessories			Mounting kit	
Optional parts			-	
Outdoor units to be combined			FDCJ140HKXE2B,224HKXE2B,280HKXE2B,FDPC140HKXE2B,224HKXE2B,280HKXE2B	

Notes (1) The data are measured at the following conditions.

Item	Indoor air temperature		Outdoor air temperature		Standards
	DB	WB	DB	WB	
Cooling* ¹	27℃	19℃	35℃	24℃	ISO-T1,JIS B8616
Heating* ²	20℃	—	7℃	6℃	

(2) This packaged air-conditioner is manufactured and tested in conformity with the following standard.
JIS B8616"UNITARY AIR-CONDITIONERS"

(3) The number "2", following the type of each model, represents"CE-marked model" especially for European Union, and for European nations which require CE marking.

(g) Wall mounted type (FDK)

Models FDKJ22HKXE2, 28HKXE2, 36HKXE2, 45HKXE2

Item	Models	FDKJ22HKXE2 ⁽³⁾	FDKJ28HKXE2 ⁽³⁾	FDKJ36HKXE2 ⁽³⁾	FDKJ45HKXE2 ⁽³⁾
		Nominal cooling capacity* ¹	W	2200	2800
Nominal heating capacity* ²	W	2500	3200	4000	5000
Power source		1 Phase 220/240V 50Hz			
Noise level	dB(A)	Hi: 40 Lo: 37	Hi: 42 Me:40 Lo: 37		Hi: 44 Me:41 Lo: 37
Exterior dimensions Height × Width × Depth	mm	375 × 930 × 194			
Net weight	kg	19			
Refrigerant equipment Heat exchanger		Louver fins & inner grooved tubing			
Refrigerant control		Electronic Expansion Valve + Capillary tube			
Air handling equipment Fan type & Qty		Centrifugal fan × 2			
Motor	W	30 × 1			35 × 1
Starting method		Line starting			
Air flow(Standard)	CMM	Hi: 9 Lo: 8	Hi: 10 Me: 9 Lo: 8		Hi: 11.5 Me: 10 Lo: 8
Fresh air intake		Not possible			
Air filter, Q'ty		Polypropylene net × 2(Washable)			
Shock & vibration absorber		Rubber sleeve(for fan motor)			
Insulation (noise & heat)		Polyurethane foam			
Operation control Operation switch		Remote control switch (Optional:RCD-HKX-S-E2)			
Room temperature control		Thermostat by electronics			
Safety equipment		Internal thermostat for fan motor. Frost protection thermostat			
Installation data Refrigerant piping size	mm(in)	Liquid line:φ 6.35(1/4"), Gas line:φ 12.7(1/2")			
Connecting method		Flare piping			
Drain hose		Connectable with I.D. 16mm			
Insulation for piping		Necessary (both Liquid & Gas lines)			
Accessories		Mounting kit			
Optional parts		—			
Outdoor units to be combined		FDCJ140HKXE2B,224HKXE2B,280HKXE2B,FDJCP140HKXE2B,224HKXE2B,280HKXE2B			

Notes (1) The data are measured at the following conditions.

Item	Indoor air temperature		Outdoor air temperature		Standards
	DB	WB	DB	WB	
Operation					
Cooling* ¹	27℃	19℃	35℃	24℃	ISO-T1,JIS B8616
Heating* ²	20℃	—	7℃	6℃	

(2) This packaged air-conditioner is manufactured and tested in conformity with the following standard.
JIS B8616"UNITARY AIR-CONDITIONERS"

(3) The number "2", following the type of each model, represents"CE-marked model" especially for European Union, and for European nations which require CE marking.

Models FDKJ56HKXE2, 71HKXE2

Item		Model	FDKJ56HKXE2 ⁽³⁾	FDKJ71HKXE2 ⁽³⁾
Nominal cooling capacity* ¹	W		5600	7100
Nominal heating capacity* ²	W		6300	8000
Power source			1 Phase 220/240V 50Hz	
Noise level	dB(A)		Hi: 46 Me:43 Lo: 39	Hi: 47 Me:44 Lo: 40
Exterior dimensions Height × Width × Depth	mm		375 × 1148 × 194	375 × 1436 × 194
Net weight	kg		20	22
Refrigerant equipment Heat exchanger			Louver fins & inner grooved tubing	
Refrigerant control			Electronic Expansion Valve + Capillary tube	
Air handling equipment Fan type & Qty			Tangential fan × 1	Tangential fan × 2
Motor	W		40 × 1	45 × 1
Starting method			Line starting	
Air flow(Standard)	CMM		Hi: 17 Me: 15 Lo: 13	Hi: 21 Me: 18 Lo: 15
Fresh air intake			Not possible	
Air filter, Q'ty			Polypropylene net × 2(Washable)	
Shock & vibration absorber			Rubber sleeve(for fan motor)	
Insulation (noise & heat)			Polyurethane foam	
Operation control Operation switch			Remote control switch (Optional:RCD-HKX-S-E2)	
Room temperature control			Thermostat by electronics	
Safety equipment			Internal thermostat for fan motor. Frost protection thermostat	
Installation data Refrigerant piping size	mm(in)		Liquid line:φ 9.52(3/8"), Gas line:φ 15.88(5/8")	
Connecting method			Flare piping	
Drain hose			Connectable with I.D. 16mm	
Insulation for piping			Necessary (both Liquid & Gas lines)	
Accessories			Mounting kit	
Optional parts			-	
Outdoor units to be combined			FDCJ140HKXE2B,224HKXE2B,280HKXE2B,FDCP140HKXE2B,224HKXE2B,280HKXE2B	

Notes (1) The data are measured at the following conditions.

Item	Indoor air temperature		Outdoor air temperature		Standards
	DB	WB	DB	WB	
Operation Cooling* ¹	27℃	19℃	35℃	24℃	ISO-T1,JIS B8616
Heating* ²	20℃	—	7℃	6℃	

(2) This packaged air-conditioner is manufactured and tested in conformity with the following standard.
JIS B8616"UNITARY AIR-CONDITIONERS"

(3) The number "2", following the type of each model, represents"CE-marked model" especially for European Union, and for European nations which require CE marking.

(h) Floor standing exposed type (FDL)

Models FDFLJ28HKXE2, 45HKXE2, 71HKXE2

Item	Model	Model		
		FDFLJ28HKXE2 ⁽³⁾	FDFLJ45HKXE2 ⁽³⁾	FDFLJ71HKXE2 ⁽³⁾
Nominal cooling capacity*1	W	2800	4500	7100
Nominal heating capacity*2	W	3200	5000	8000
Power source		1 Phase 220/240V 50Hz		
Noise level	dB(A)	Hi: 41 Me:38 Lo: 36	Hi: 43 Me:41 Lo: 40	
Exterior dimensions Height × Width × Depth	mm	630 × 1196 × 225		630 × 1481 × 225
Net weight	kg	32		40
Refrigerant equipment Heat exchanger		Louver fins & inner grooved tubing		
Refrigerant control		Electronic Expansion Valve + Capillary tube		
Air handling equipment Fan type & Q'ty		Centrifugal fan × 2		
Motor	W	30 × 1	40 × 1	
Starting method		Line starting		
Air flow(Standard)	CMM	Hi: 12 Me: 11 Lo: 10	Hi: 14 Me: 12 Lo: 10	Hi: 18 Me: 15 Lo: 12
Fresh air intake		Not possible		
Air filter, Q'ty		Polypropylene net × 2(Washable)		
Shock & vibration absorber		Rubber sleeve(for fan motor)		
Insulation (noise & heat)		Polyurethane foam		
Operation control Operation switch		Remote control switch (Optional:RCD-HKXFL-E2)		
Room temperature control		Thermostat by electronics		
Safety equipment		Internal thermostat for fan motor. Frost protection thermostat		
Installation data Refrigerant piping size	mm(in)	Liquid line: 6.35(1/4"), Gas line: 12.7(1/2")		Liquid line: 9.52(3/8") Gas line: 15.88(5/8")
Connecting method		Flare piping		
Drain hose		Connectable with VP20		
Insulation for piping		Necessary (both Liquid & Gas lines)		
Accessories		Mounting kit		
Optional parts		-		
Outdoor units to be combined		FDCJ140HKXE2B, 224HKXE2B, 280HKXE2B, FDCP140HKXE2B, 224HKXE2B, 280HKXE2B		

Notes (1) The data are measured at the following conditions.

Item	Indoor air temperature		Outdoor air temperature		Standards
	DB	WB	DB	WB	
Operation Cooling*1	27℃	19℃	35℃	24℃	ISO-T1,JIS B8616
Heating*2	20℃	—	7℃	6℃	

(2) This packaged air-conditioner is manufactured and tested in conformity with the following standard.
JIS B8616"UNITARY AIR-CONDITIONERS"

(3) The number "2", following the type of each model, represents"CE-marked model" especially for European Union, and for European nations which require CE marking.

(i) Floor standing hidden type (FDFU)

Models FDFUJ28HKXE2, 45HKXE2, 56HKXE2, 71HKXE2

Item	Model	Model			
		FDFUJ28HKXE2 ⁽³⁾	FDFUJ45HKXE2 ⁽³⁾	FDFUJ56HKXE2 ⁽³⁾	FDFUJ71HKXE2 ⁽³⁾
Nominal cooling capacity*1	W	2800	4500	5600	7100
Nominal heating capacity*2	W	3200	5000	6300	8000
Power source		1 Phase 220/240V 50Hz			
Noise level	dB(A)	Hi: 41 Me:38 Lo: 36	Hi: 43 Me:41 Lo: 40		
Exterior dimensions Height × Width × Depth	mm	630 × 1077 × 225			630 × 1362 × 225
Net weight	kg	25			32
Refrigerant equipment Heat exchanger		Louver fins & inner grooved tubing			
Refrigerant control		Electronic Expansion Valve + Capillary tube			
Air handling equipment Fan type & Qty		Centrifugal fan × 2			
Motor	W	30 × 1	40 × 1		
Starting method		Line starting			
Air flow(Standard)	CMM	Hi: 12 Me: 11 Lo: 10	Hi: 14 Me: 12 Lo: 10		Hi: 18 Me: 15 Lo: 12
Fresh air intake		Not possible			
Air filter, Q'ty		Polypropylene net × 2(Washable)			
Shock & vibration absorber		Rubber sleeve(for fan motor)			
Insulation (noise & heat)		Polyurethane foam			
Operation control Operation switch		Remote control switch (Optional:RCD-HKXFL-E2)			
Room temperature control		Thermostat by electronics			
Safety equipment		Internal thermostat for fan motor. Frost protection thermostat			
Installation data Refrigerant piping size	mm(in)	Liquid line:φ 6.35(1/4"), Gas line: φ 12.7(1/2")		Liquid line:φ 9.52(3/8") Gas line: φ 15.88(5/8")	
Connecting method		Flare piping			
Drain hose		Connectable with VP20			
Insulation for piping		Necessary (both Liquid & Gas lines)			
Accessories		Mounting kit			
Optional parts		-			
Outdoor units to be combined		FDCJ140HKXE2B, 224HKXE2B, 280HKXE2B, FDCP140HKXE2B, 224HKXE2B, 280HKXE2B			

Notes (1) The data are measured at the following conditions.

Operation	Item	Indoor air temperature		Outdoor air temperature		Standards
		DB	WB	DB	WB	
Cooling*1		27℃	19℃	35℃	24℃	ISO-T1,JIS B8616
Heating*2		20℃	—	7℃	6℃	

(2) This packaged air-conditioner is manufactured and tested in conformity with the following standard.
JIS B8616"UNITARY AIR-CONDITIONERS"

(3) The number "2", following the type of each model, represents"CE-marked model" especially for European Union, and for European nations which require CE marking.

(2) Outdoor unit

(a) Alternative refrigerant R407C use models

Models FDCP140HKXE2B, 224HKXE2B, 280HKXE2B

Item	Models	FDCP140HKXE2B ⁽³⁾	FDCP224HKXE2B ⁽³⁾	FDCP280HKXE2B ⁽³⁾
Power source		3 Phase 380/415V 50Hz		
Nominal cooling capacity* ¹	W	14000	22400	28000
Nominal heating capacity* ²	W	16000	25000	31500
Noise level	dB(A)	56	58	59
Exterior dimensions Height × Width × Depth	mm	1450 × 690 × 600	1450 × 1350 × 600	
Net weight	kg	150	250	275
Refrigerant equipment compressor type & Q' ty		GT-A5539HAS51 × 1	GT-A5539HAS52 × 1 GT-A5539HS52 × 1	GT-A5539HAS52 × 1 GU-A5570HS52 × 1
Motor	kW	3.5	3.5 × 1, 2.2 × 1	3.5 × 1, 3.75 × 1
Starting method		Direct start		
Capacity control	%	100 ~ 25	100 ~ 16	100 ~ 12
Crankcase heater	W	33	33 × 2	33 × 1, 40 × 1
Heat exchanger		Louver fines & inner grooved tubing		
Refrigerant control		Expansion Valve +Capillary tube		
Refrigerant		R407C		
Quantity	kg	9	12	
Refrigerant oil	ℓ	1.45 (MA32)	2.9 (MA32)	3.05 (MA32)
Defrost control		MC controlled De-Icer		
Air handling equipment Fan type & Q' ty		Centrifugal fan × 1	Centrifugal fan × 2	
Motor	W	100 × 1	100 × 2	
Starting method		Direct start		
Air flow(Standard)	CMM	90	180	
Shock & vibration absorber		Rubber mount (for compressor)		
Safety equipment		Compressor overheat protection, overcurrent protection, power transformer overheating protection, abnormal high pressure protection		
Installation data Refrigerant piping size	mm(in)	Liquid line: φ9.52(3/8") Gas line: φ19.05(3/4")	Liquid line: φ12.7(1/2") Gas line: φ25.4(1")	Liquid line: φ12.7(1/2") Gas line: φ28.58(1 1/8")
Connecting method		Brazing		
Drain		Hole for drain(φ20 × 4pcs)	Hole for drain(φ20 × 8pcs, φ50 × 1pcs)	
Insulation for piping		Necessary (both Liquid & Gas lines)		
Accessories		-		
Indoor units to be combined		FDTJ28, 36, 45, 56, 71, 90, 112, 140type FDTWJ28, 45, 56, 71, 90, 112, 140type FDTSJ22, 28, 36, 45, 71type FDRJ22, 28, 45, 56, 71, 90, 112, 140type FDUMJ36, 45, 56, 71, 90, 112, 140type FDEJ36, 45, 56, 71, 112, 140type FDKJ22, 28, 36, 45, 56, 71type FDLJ28, 45, 71type	FDFUJ28, 45, 56, 71type	

Notes (1) The cooling and heating capabilities imply the values when the indoor unit of rated capacity is connected under the condition specified in JIS-B8616.

(2) The refrigerant quantity in the connecting pipe is not included Charge it additionally at the site.

(3) The number "2", following the type of each model, represents "CE-marked model" especially for European Union, and for European nations which require CE marking.

Refrigerant distributor pipe set Number list (Optional)

Outdoor unit	Number of combined indoor units	Flow divider pipe ⁽¹⁾ (Total capacity after the flow division)
FDCP140HKXE2B	1~8	Downstream capacity 101 or less : DIS-2KX10-E
FDCP224HKXE2B	1~13 ⁽²⁾	Downstream capacity 180 or less : DIS-2KX20-E
FDCP280HKXE2B	1~16 ⁽²⁾	Downstream capacity 180 or more : DIS-2KX30-E

Notes (1) The flow divider pipe that should be used depends on the indoor unit total downstream capacity. (1 set is required for each flow division.)

(2) When there are 13 or more indoor units there are limits on the length of the piping after the flow division, so refer to the usage range.

(b) Refrigerant R22 use models

Models FDCJ140HKXE2B, 224HKXE2B, 280HKXE2B

Item	Models	FDCJ140HKXE2B ⁽³⁾	FDCJ224HKXE2B ⁽³⁾	FDCJ280HKXE2B ⁽³⁾
Power source		3 Phase 380/415V 50Hz		
Nominal cooling capacity* ¹	W	14000	22400	28000
Nominal heating capacity* ²	W	16000	25000	31500
Noise level	dB(A)	56	58	59
Exterior dimensions Height × Width × Depth	mm	1450 × 690 × 600	1450 × 1350 × 600	
Net weight	kg	150	250	275
Refrigerant equipment compressor type & Q'ty		GT-A5539EAS51 × 1	GT-A5539EAS52 × 1 GT-A5539ES52 × 1	GT-A5539EAS52 × 1 GU-A5570ES52 × 1
Motor	kW	3.5	3.5 × 1, 2.2 × 1	3.5 × 1, 3.75 × 1
Starting method		Direct start		
Capacity control	%	100 ~ 25	100 ~ 16	100 ~ 12
Crankcase heater	W	33	33 × 2	33 × 1, 40 × 1
Heat exchanger		Louver fines & inner grooved tubing		
Refrigerant control		Expansion Valve +Capillary tube		
Refrigerant		R22		
Quantity	kg	9	12	
Refrigerant oil	ℓ	1.45 (BARREL FREEZE 32SAM)	2.9 (BARREL FREEZE 32SAM)	3.05 (BARREL FREEZE 32SAM)
Defrost control		MC controlled De-Icer		
Air handling equipment Fan type & Q'ty		Centrifugal fan × 1	Centrifugal fan × 2	
Motor	W	100 × 1	100 × 2	
Starting method		Direct start		
Air flow(Standard)	CMM	90	180	
Shock & vibration absorber		Rubber mount (for compressor)		
Safety equipment		Compressor overheat protection, overcurrent protection, power transformer overheating protection, abnormal high pressure protection		
Installation data Refrigerant piping size	mm(in)	Liquid line: φ9.52(3/8") Gas line: φ19.05(3/4")	Liquid line: φ12.7(1/2") Gas line: φ25.4(1")	Liquid line: φ12.7(1/2") Gas line: φ28.58(1 1/8")
Connecting method		Brazeing		
Drain		Hole for drain(φ20 × 4pcs)	Hole for drain(φ20 × 8pcs, φ50 × 1pcs)	
Insulation for piping		Necessary (both Liquid & Gas lines)		
Accessories		-		
Indoor units to be combined		FDTJ28, 36, 45, 56, 71, 90, 112, 140type FDTWJ28, 45, 56, 71, 90, 112, 140type FDTSJ22, 28, 36, 45, 71type FDRJ22, 28, 45, 56, 71, 90, 112, 140type FDUMJ36, 45, 56, 71, 90, 112, 140type FDEJ36, 45, 56, 71, 112, 140type FDKJ22, 28, 36, 45, 56, 71type FDFLJ28, 45, 71type	FDFUJ28, 45, 56, 71type	

- Notes (1) The cooling and heating capabilities imply the values when the indoor unit of rated capacity is connected under the condition specified in JIS-B8616.
(2) The refrigerant quantity in the connecting pipe is not included Charge it additionally at the site.
(3) The number "2", following the type of each model, represents "CE-marked model" especially for European Union, and for European nations which require CE marking.

Refrigerant distributor pipe set Number list (Optional)

Outdoor unit	Number of combined indoor units	Flow divider pipe ⁽¹⁾ (Total capacity after the flow division)
FDCJ140HKXE2B	1~8	Downstream capacity 101 or less : DIS-2KX10-E
FDCJ224HKXE2B	1~13 ⁽²⁾	Downstream capacity 180 or less : DIS-2KX20-E
FDCJ280HKXE2B	1~16 ⁽²⁾	Downstream capacity 180 or more : DIS-2KX30-E

- Notes (1) The flow divider pipe that should be used depends on the indoor unit total downstream capacity. (1 set is required for each flow division.)
(2) When there are 13 or more indoor units there are limits on the length of the piping after the flow division, so refer to the usage range.

(3) Operation chart

Since the Multi KX series air conditioner units are free multitype to which the indoor units of different capacity and different model can be combined, the operation characteristics of all combinations are very complicated, therefore only the individual operation characteristics of indoor and outdoor units are shown. For the combined operation characteristics, calculate them with the method shown in the next page.

(a) Operating characteristic of outdoor unit

(380 V/415 V)

Item	Models		FDCJ140HKXE2B	FDCJ224HKXE2B	FDCJ280HKXE2B
Cooling input	kW		6.8/6.8	9.8/9.8	11.7/11.7
Heating input			5.7/5.9	8.3/8.4	9.7/9.8
Cooling running current	A		10.7/10.2	15.7/14.6	19.3/19.0
Heating running current			8.8/8.4	13.0/12.0	15.7/15.7
Inrush current (MAX.)	A		5	48	70
Cooling power factor	%		97/93	95/93	92/86
Heating power factor			98/98	97/97	94/95

(380 V/415 V)

Item	Models		FDCP140HKXE2B	FDCP224HKXE2B	FDCP280HKXE2B
Cooling input	kW		6.8/6.8	9.8/9.8	11.7/11.7
Heating input			6.0/6.1	9.3/9.4	11.2/11.4
Cooling running current	A		10.7/10.2	15.7/14.6	19.3/19.0
Heating running current			9.3/8.6	14.7/14.0	17.6/16.8
Inrush current (MAX.)	A		5	48	70
Cooling power factor	%		97/93	95/93	92/86
Heating power factor			98/99	96/93	97/94

Note (1) This packaged air-conditioner is manufactured and tested in conformity with the following standard.
JIS B8616 "UNITARY AIR-CONDITIONERS"

(b) Operating characteristic of indoor unit

FDT Series

(220 V/240 V)

Item	Models		FDT Series					
	28	36	45	56	71	90	112	140
Power input (kW)	0.09/0.10		0.10/0.12		0.10/0.12	0.11/0.13	0.17/0.20	0.21/0.24
Running current (A)	0.40/0.44		0.45/0.49		0.47/0.50	0.50/0.55	0.75/0.81	0.93/1.02

FDTW Series

(220 V/240 V)

Item	Models		FDTW Series				
	28	45	56	71	90	112	140
Power input (kW)	0.09/0.10		0.10/0.11	0.12/0.13	0.18/0.20	0.20/0.24	
Running current (A)	0.43/0.44	0.43/0.43		0.48/0.50	0.57/0.59	0.86/0.89	0.90/0.98

Notes (1) This packaged air-conditioner is manufactured and tested in conformity with the following standard.
JIS B8616 "UNITARY AIR-CONDITIONERS"

(2) The values shown in the above table are common to both cooling and heating operations.

Operation characteristics of each unit

(Cooling/Heating)

Item \ Models	FDCJ224HKXE2B	FDTJ71HKXE2	FDTJ45HKXE2
Power input (kW)	9.8/8.3	0.10/0.10	0.10/0.10
Running current (A)	15.7/13.0	0.47/0.47	0.45/0.45

① Total power input (kW)

(Cooling) $9.8 + (0.10 \times 4) = 10.2$ (kW)

(Heating) $8.3 + (0.10 \times 4) = 8.7$ (kW)

② Total running current (A)

(Cooling) $15.7 + (0.47 \times 2 + 0.45 \times 2) \times \frac{2}{3} \doteq 16.9$ (A)

(Heating) $13.0 + (0.47 \times 2 + 0.45 \times 2) \times \frac{2}{3} \doteq 14.2$ (A)

③ Total power factor (%)

(Cooling) $\frac{10.2 \times 1000}{\sqrt{3} \times 16.9 \times 380} \times 100 \doteq 92$ %

(Heating) $\frac{8.7 \times 1000}{\sqrt{3} \times 14.2 \times 380} \times 100 \doteq 93$ %

(d) Calculation of system power input for operation hertz of compressor

Note (1) This package air-conditioner in JIS B8616.

$$\text{System's total power input (kW)} = \underbrace{A \times B + C}_{\text{For compressor}} + \underbrace{(D_1 \times N_1 + D_2 \times N_2 + \dots)}_{\text{For operation indoor unit}}$$

For compressor

For outdoor fan

For operation indoor unit

A: Compressor power input in rated operation <kW>

B: Correction factor of power input by operation frequency of compressor.

C: Power input of outdoor fan <kW>

D: Power input of a indoor unit <kW>

N: Number of operation indoor units.

1) Correction factor of compressor power input

Models FDCJ140HKXE2B, FDCP140HKXE2B

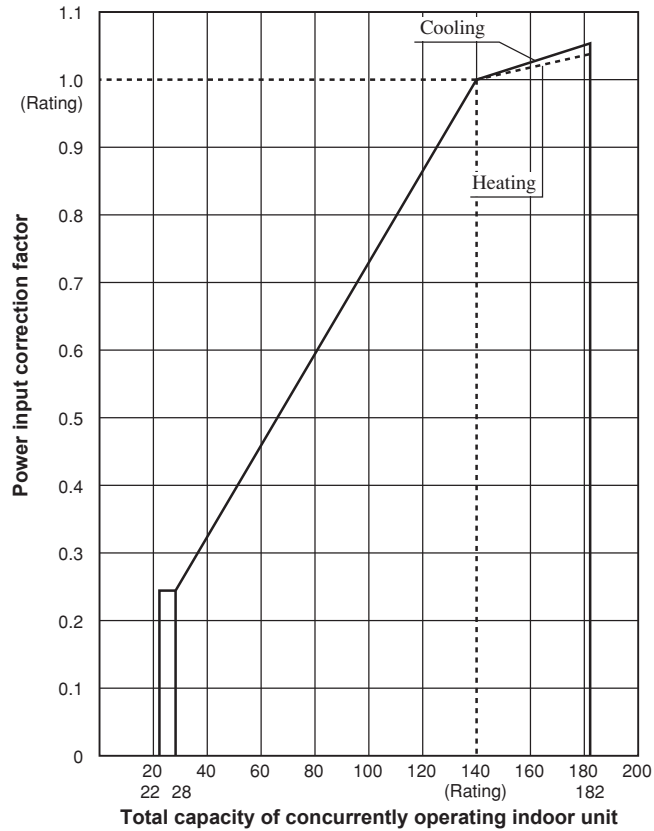

Models FDCJ224HKXE2B, FDCP224HKXE2B

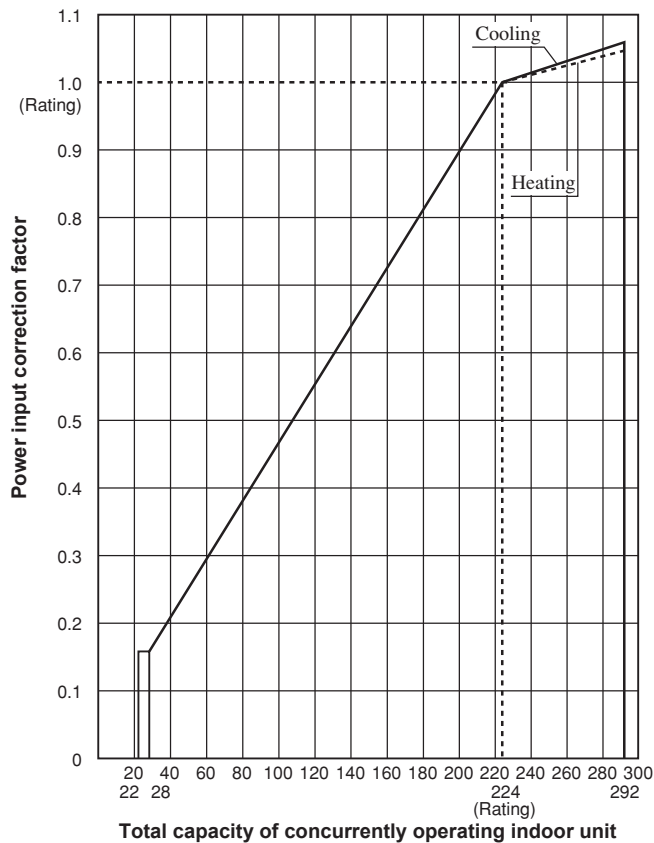

Models FDCJ280HKXE2B, FDCP280HKXE2B

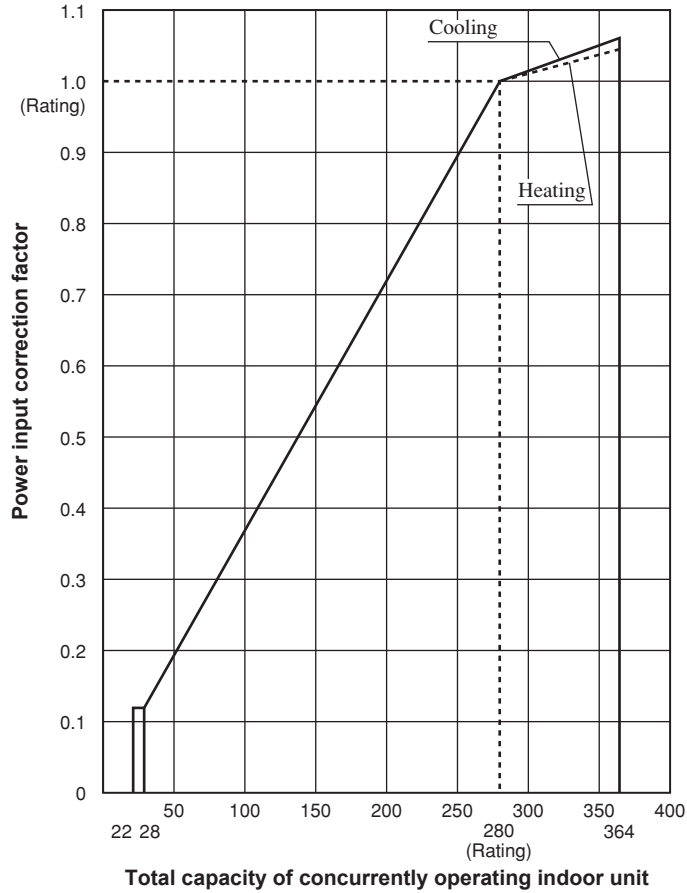

2) Compressor and outdoor fan power input in rated operation.

(380 V/415V)

Outdoor unit	Power input (kW)	Compressor		Outdoor fan
		Cooling	Heating	
FDCJ140HKXE2B		6.56/6.56	5.46/5.66	0.24/0.24
FDCJ224HKXE2B		9.33/9.33	7.83/7.93	0.47/0.47
FDCJ280HKXE2B		11.23/11.23	9.23/9.33	0.47/0.47

Outdoor unit	Power input (kW)	Compressor		Outdoor fan
		Cooling	Heating	
FDCP140HKXE2B		6.56/6.56	5.76/5.86	0.24/0.24
FDCP224HKXE2B		9.33/9.33	8.83/8.93	0.47/0.47
FDCP280HKXE2B		11.23/11.23	10.73/10.93	0.47/0.47

3) Power input of indoor unit

See page 752, operation characteristics of relevant units.

19.2.2 Range of usage & limitations

System		FDCP140HKXE2B FDCJ140HKXE2B	FDCP224HKXE2B FDCJ224HKXE2B	FDCP280HKXE2B FDCJ280HKXE2B
		Item		
Indoor intake air temperature (Upper, lower limits)		Refer to the capacity characteristics.		
Outdoor air temperature (Upper, lower limits)				
Indoor units that can be used in combination	Number of connected units	1 to 8 units	1 to 13 units	1 to 16 units
	Total capacity	70 ~ 182	112 ~ 292	140 ~ 364
Single direction piping length		Indoor unit MAX. 100m		
Outdoor unit to first branching (main piping)		Max. 70m		
Piping length after the first branching		Max. 40m	Max. 40m when the connected No. of indoor unit are up to 12 units Max. 30m when the connected No. of indoor units are 13 units or more	
Difference in height between indoor and outdoor units	When above outdoor unit	MAX. 50m		
	When below outdoor unit	MAX. 40m		
Difference in height between indoor units		MAX. 15m		
Indoor unit atmosphere (behind ceiling) temperature and humidity		Dew point temperature 28 °C or less, relative humidity 80% or less		
Compressor stop/start frequency	1 cycle time	6 min or more(from stop to stop or from start to start)		
	Stop time	3 min or more		
Power source voltage	Voltage fluctuation	Within ±10% of rated voltage		
	Voltage drop during start	Within ±15% of rated voltage		
	Interval unbalance	Within ± 3% of rated voltage		

Allowable length of refrigerant piping, height difference between indoor and outdoor unit

(1) Branch pipe method (using branch Pipe)

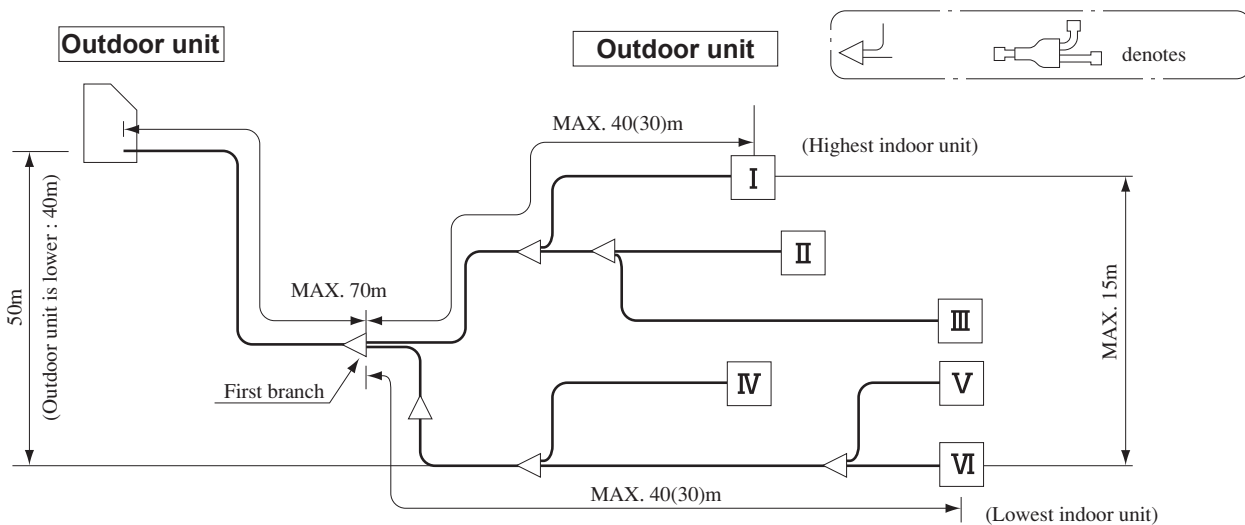

Note (1) Value in () indicates when the connected No. of indoor units are 13 units or more. (FDCJ(P) 224, 280 only)

19.2.3 Exterior dimensions

(1) Indoor unit

(a) Ceiling recessed type (FDT)

Models FDTJ28HKXE2, 36HKXE2, 45HKXE2, 56HKXE2, 71HKXE2, 90HKXE2

Unit : mm

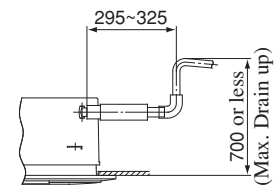
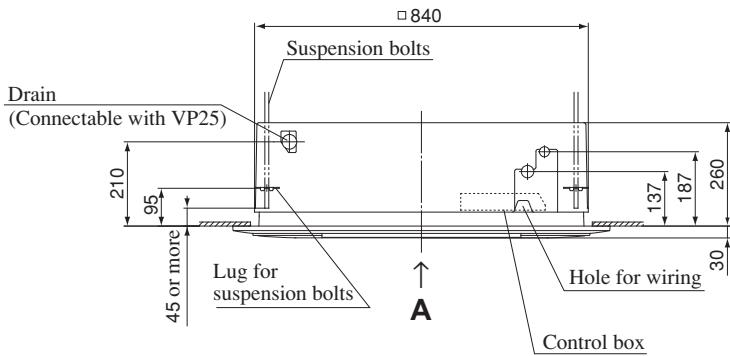
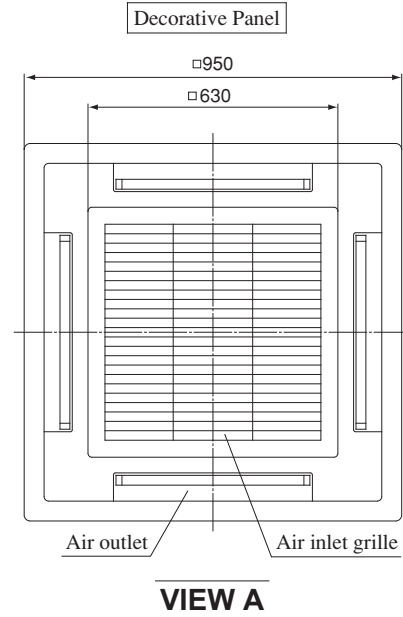
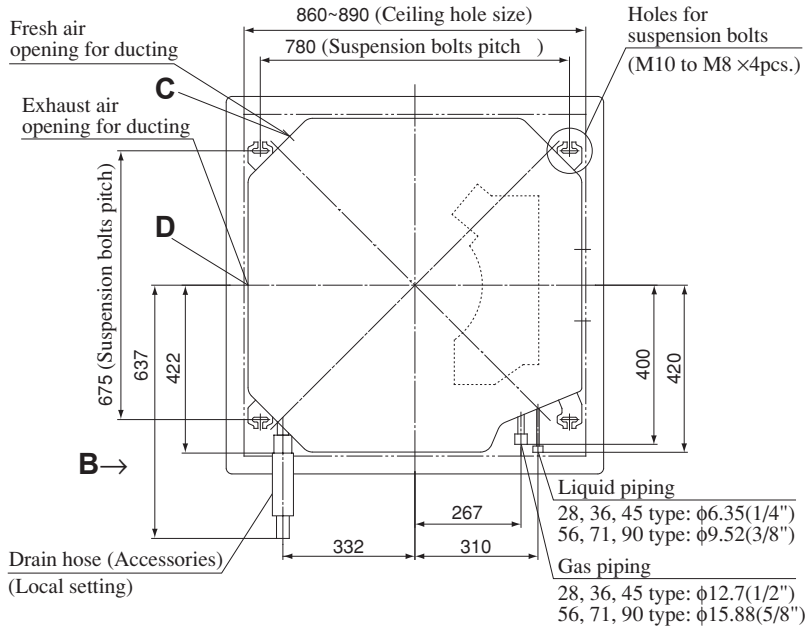

VIEW B

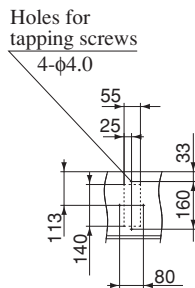

VIEW C

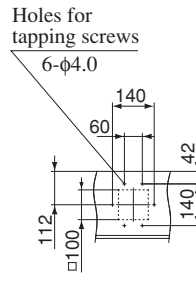

VIEW D

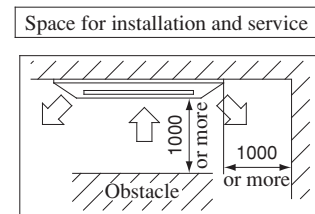

Models FDTJ112HKXE2, 140HKXE2

Unit : mm

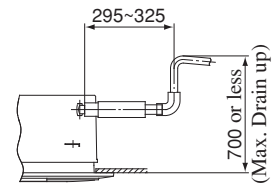
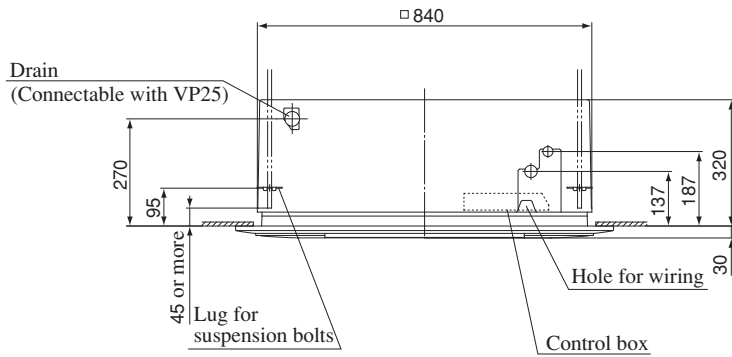
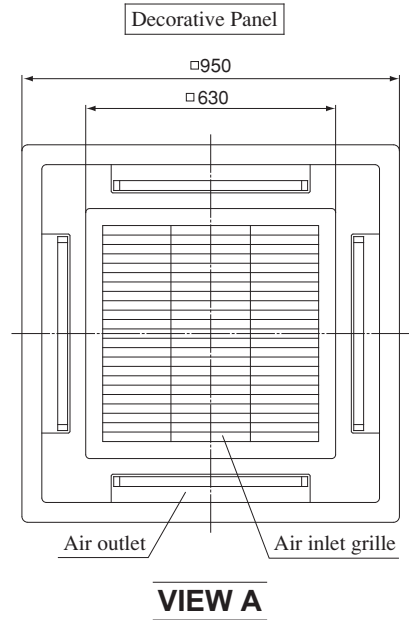
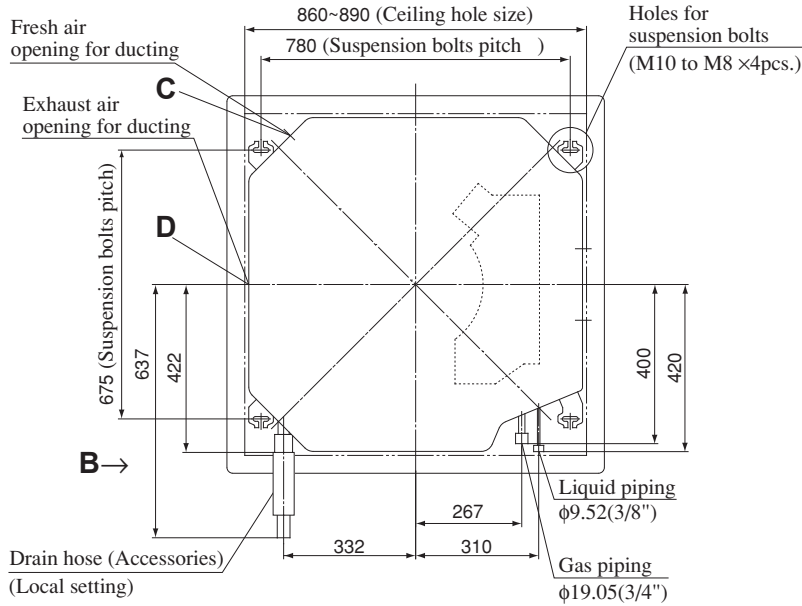

VIEW B

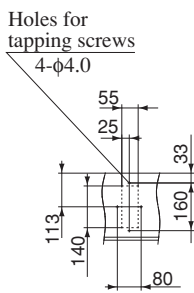

VIEW C

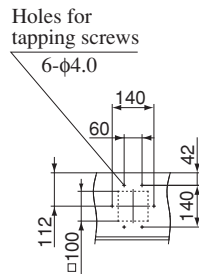

VIEW D

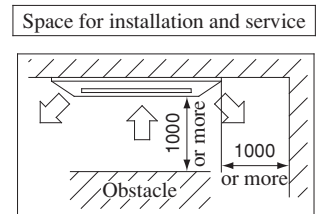

(b) 2-way outlet ceiling recessed type (FDTW)
Models FDTWJ28HKXE2B, 45HKXE2B, 56HKXE2B

Unit : mm

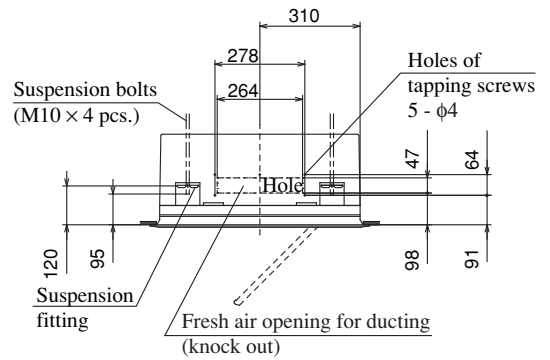
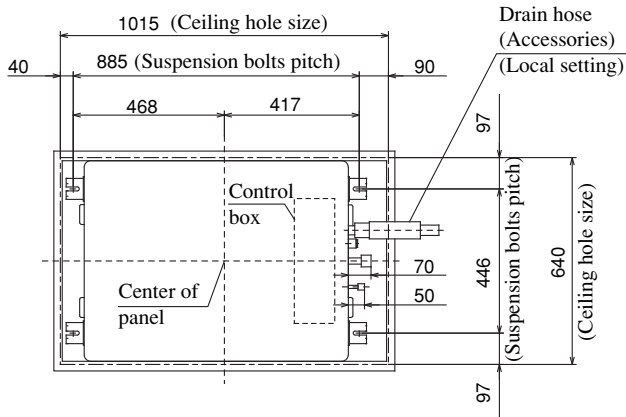

VIEW A

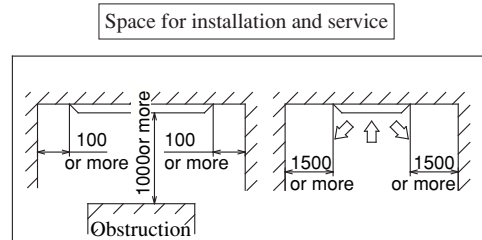
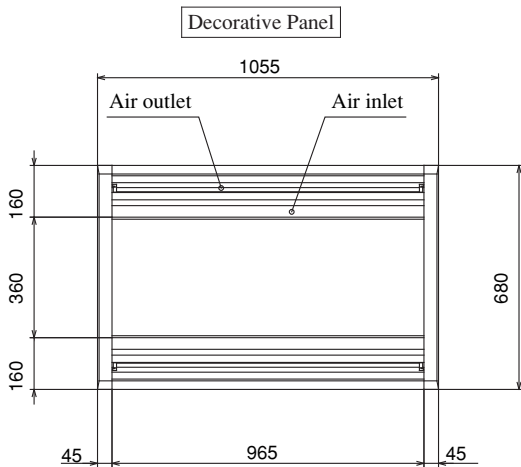
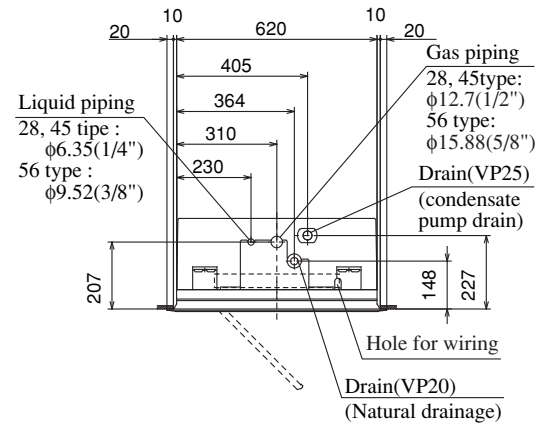
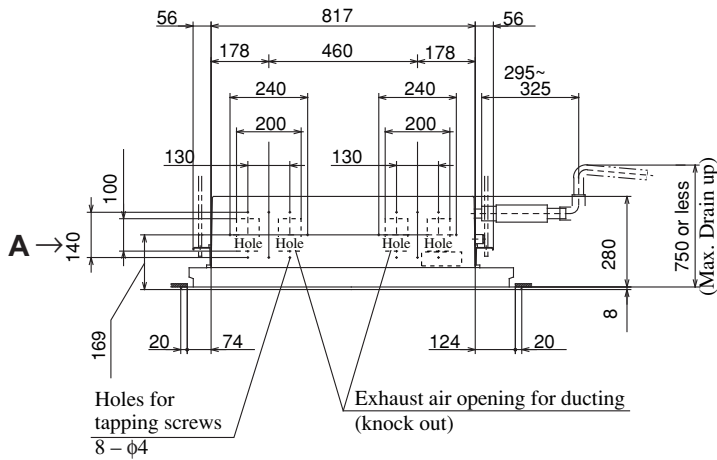

Models FDTWJ71HKXE2B, 90HKXE2B

Unit : mm

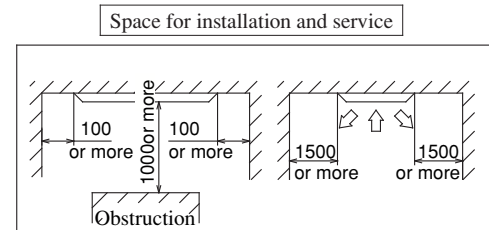
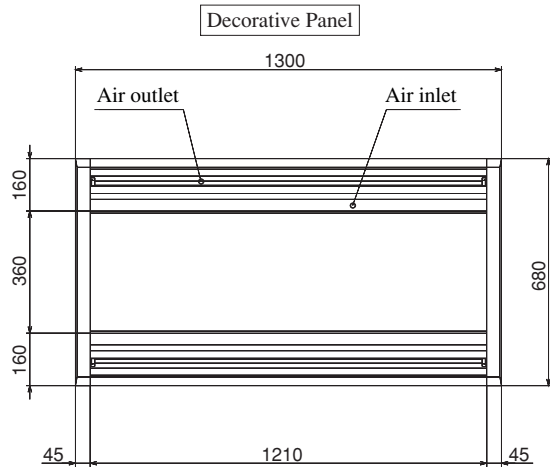
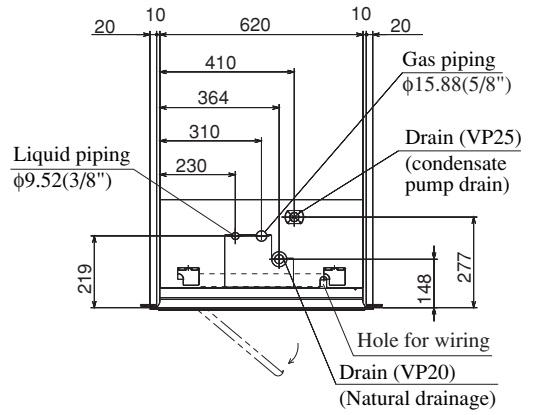
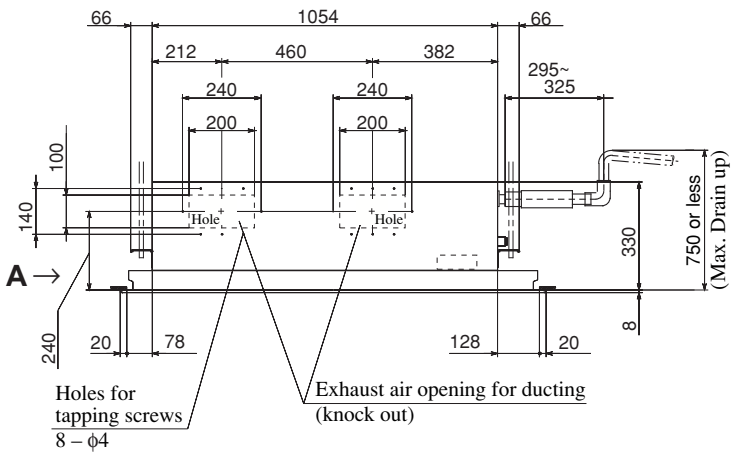
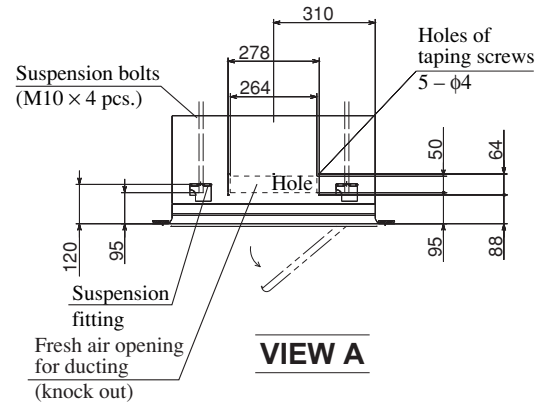
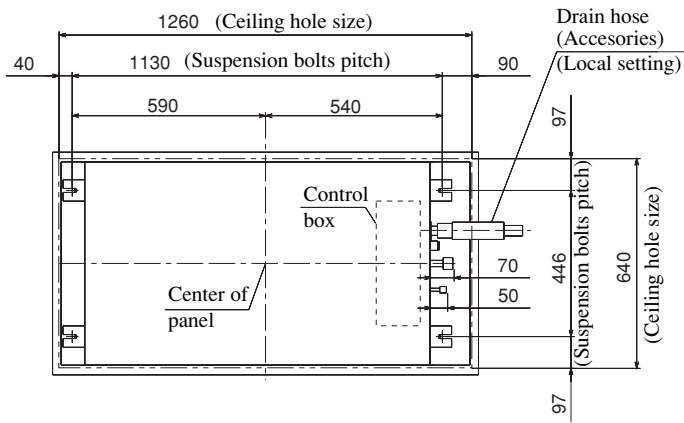

Models FDTWJ112HKXE2B, 140HKXE2B

Unit: mm

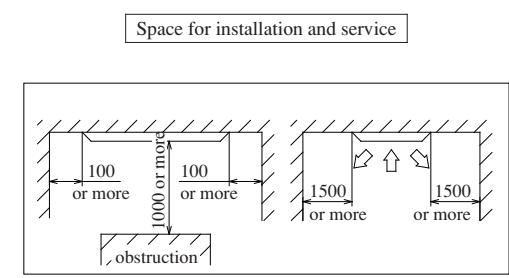
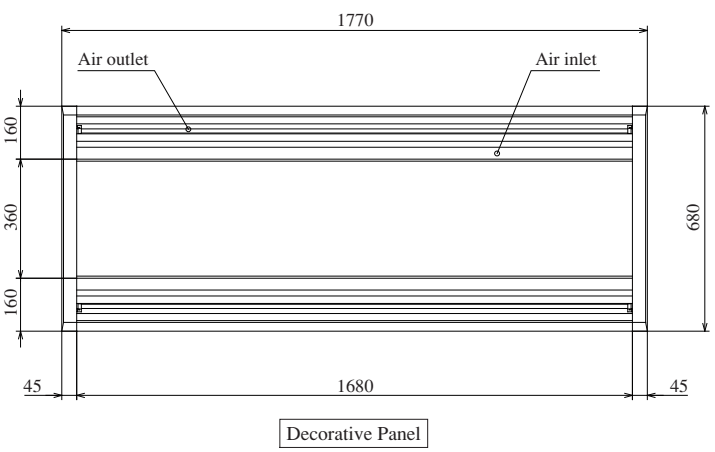
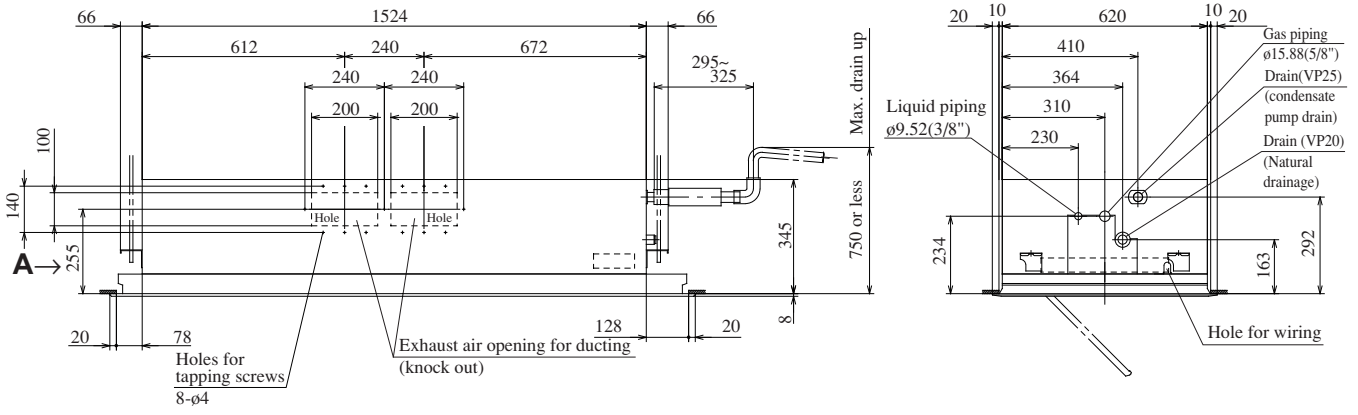
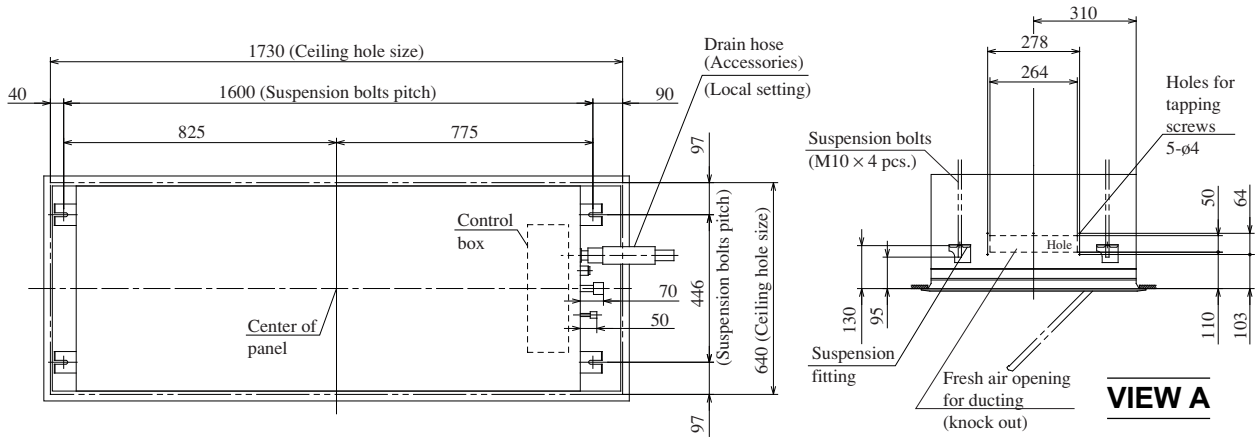

(c) 1-Way outlet ceiling recessed type (FDTS)

Models FDTSJ22HKXE2B, 28HKXE2B, 36HKXE2B, 45HKXE2B

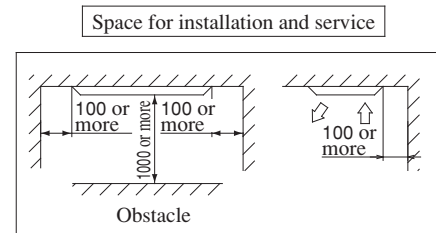
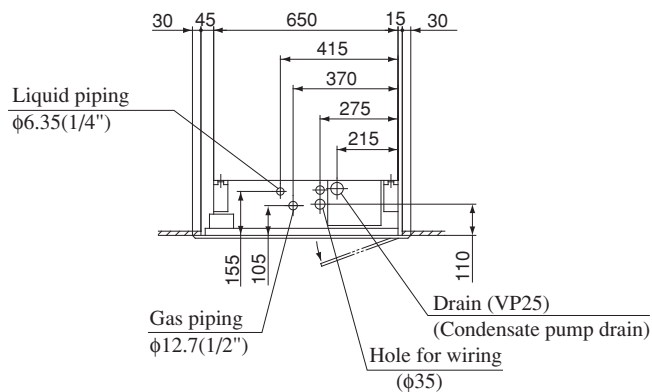
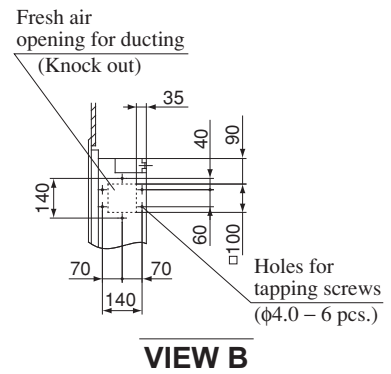
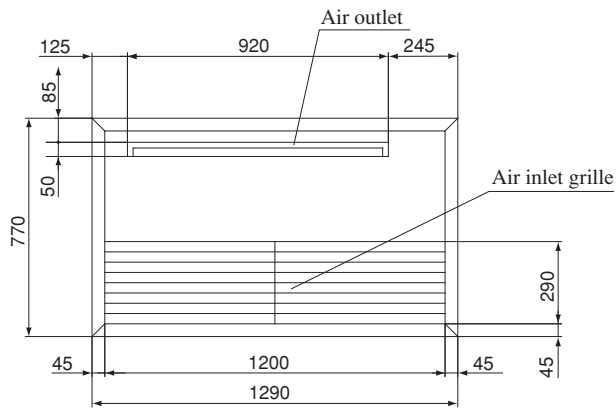
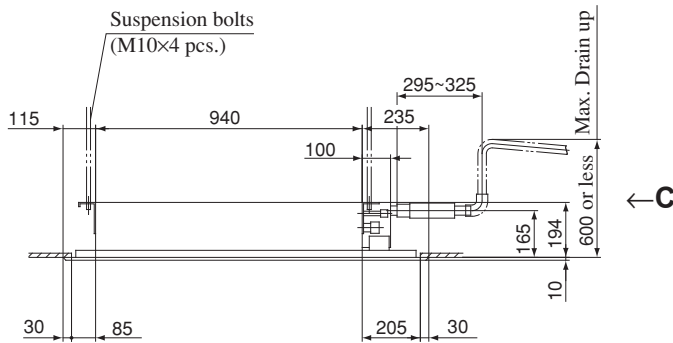
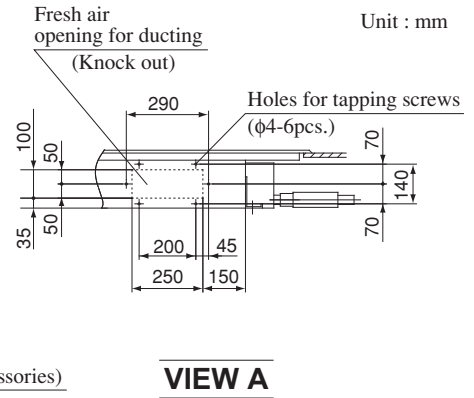
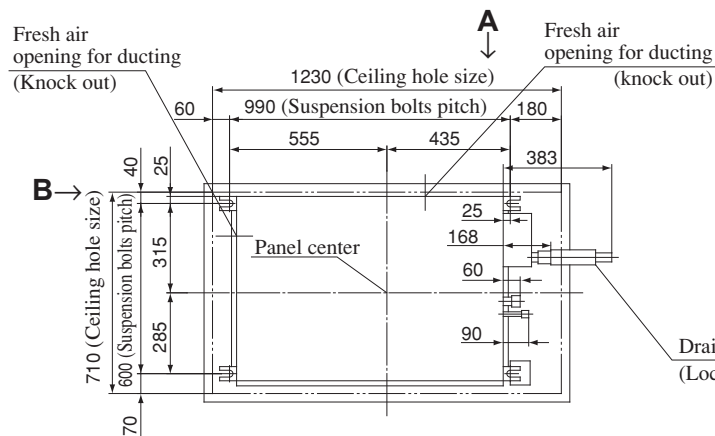

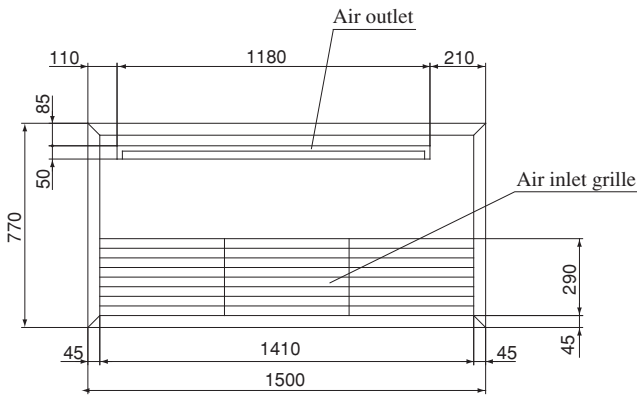
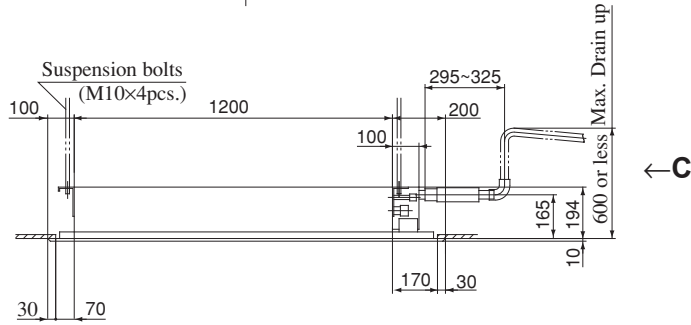
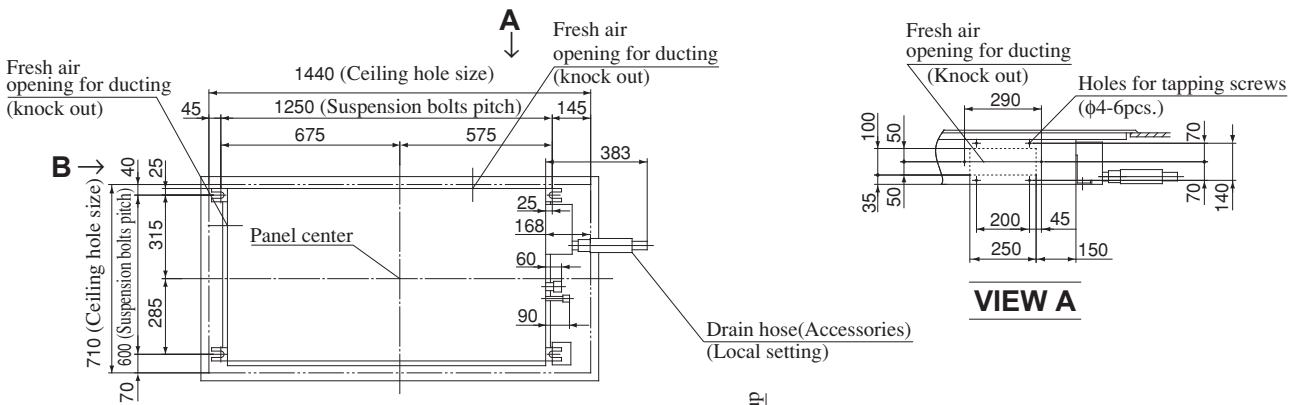

Decorative Panel

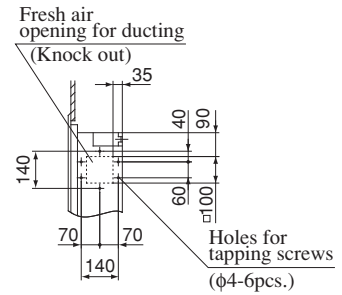

VIEW B

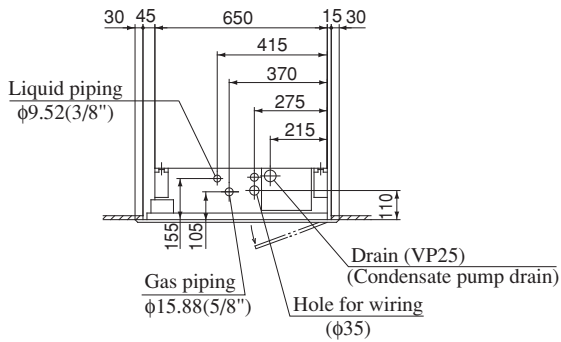

VIEW C

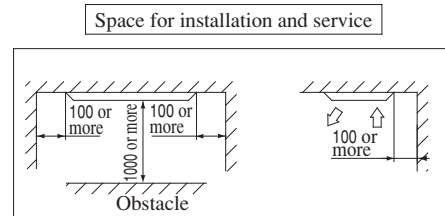

(d) Cassetteria type (FDR)

Model FDRJ22HKXE2

Silent Panel (Model: R-PNLS-26W-E)

Unit : mm

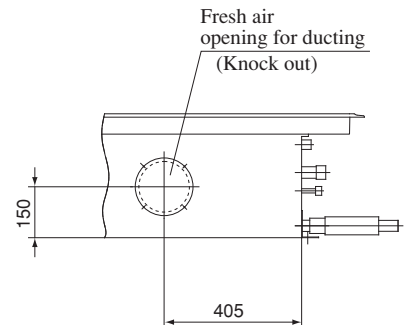
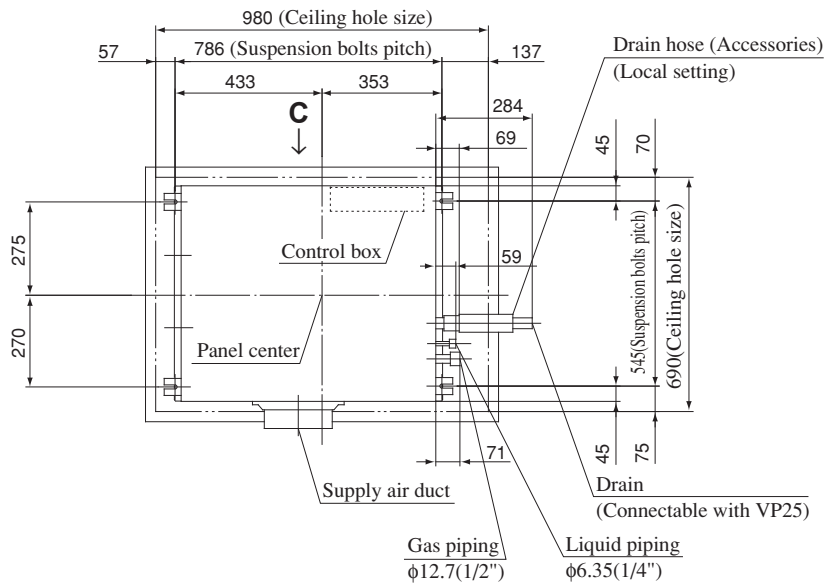

VIEW C

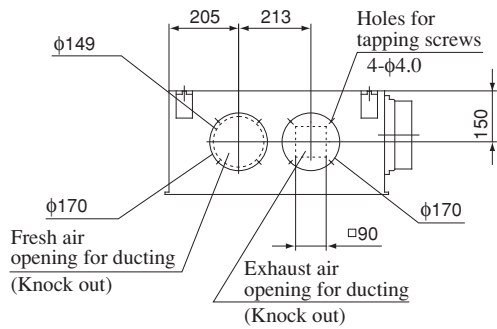
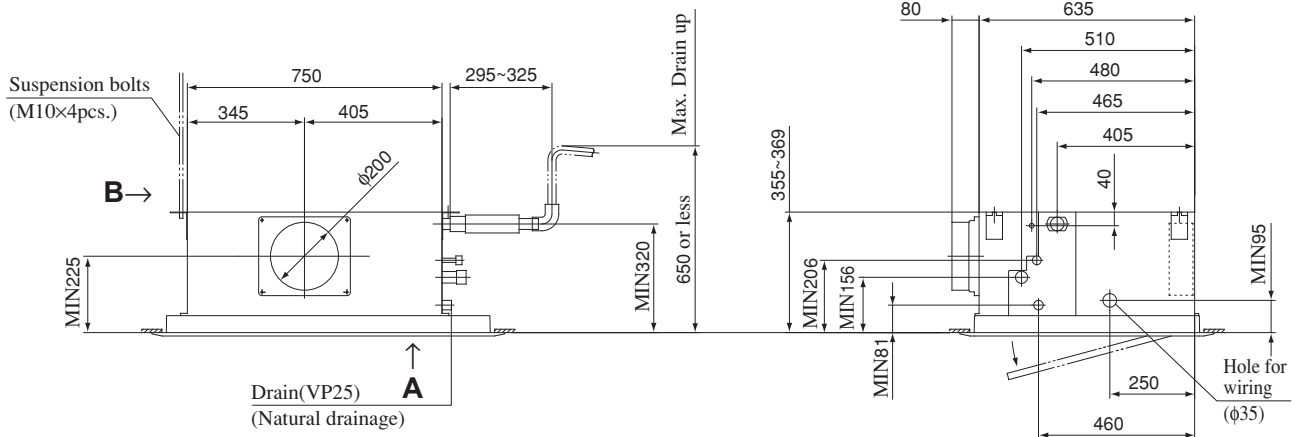

VIEW B

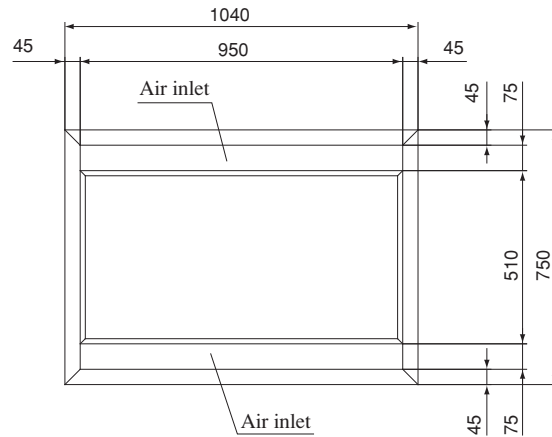
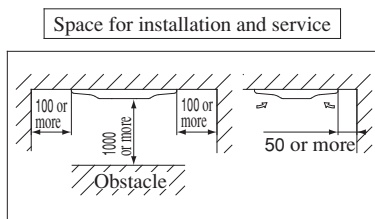

VIEW A

Canvas Panel (Model: R-PNLC -26W-E)

Unit : mm

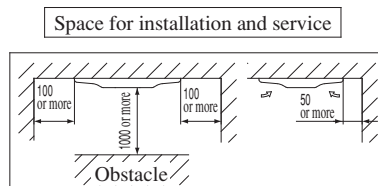
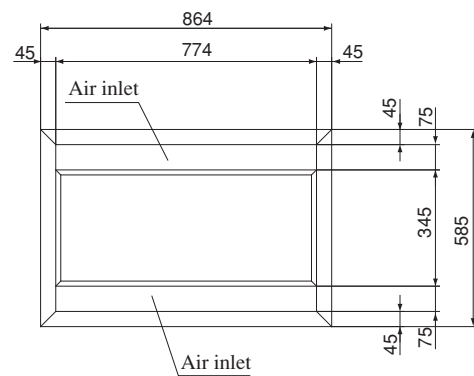
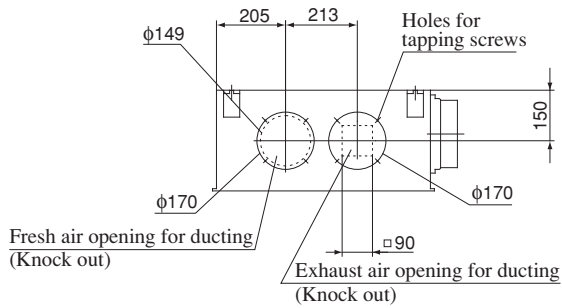
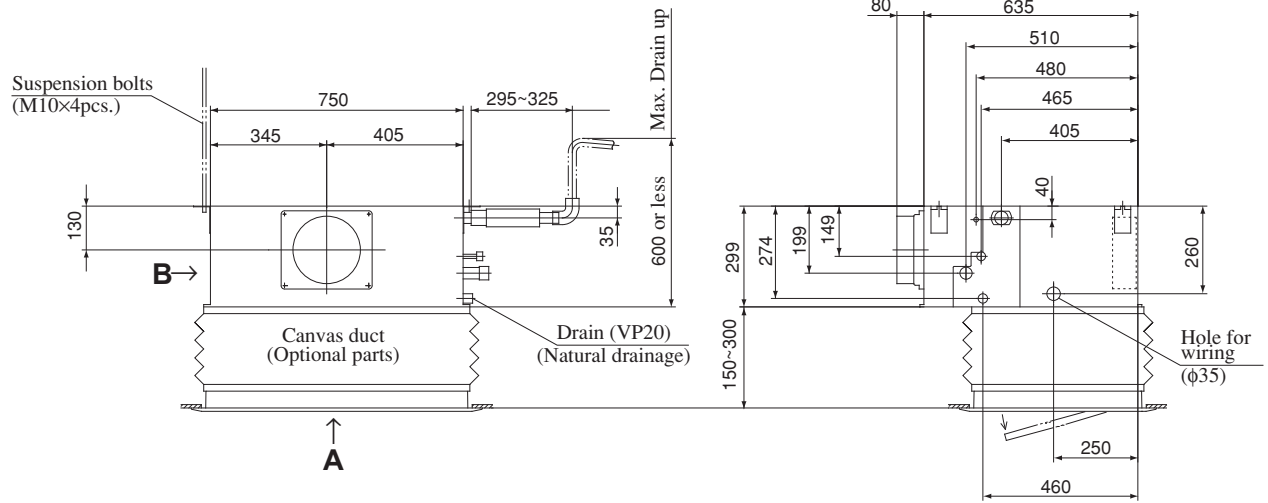
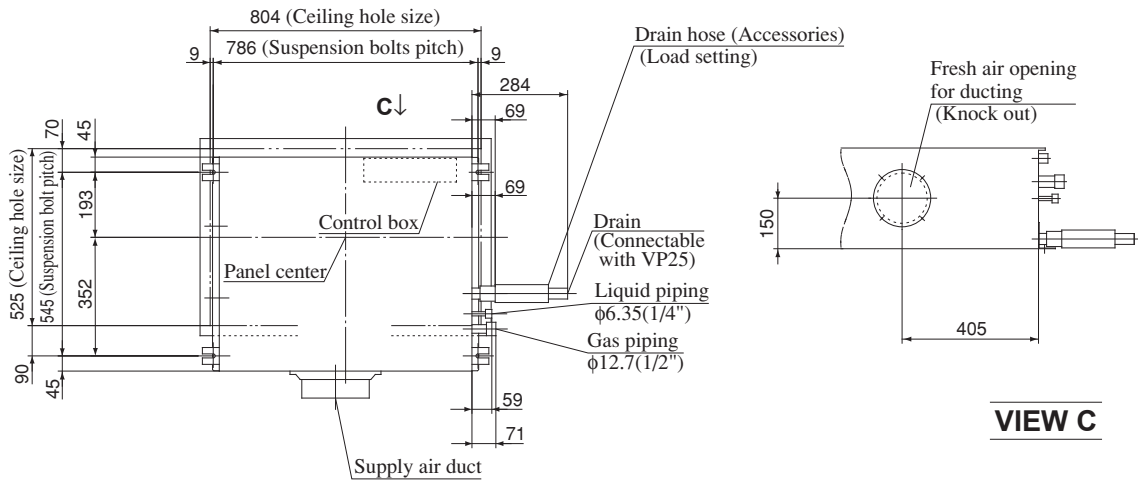

Models FDRJ28HKXE2, 45HKXE2, 56HKXE2

Silent Panel (Model: R-PNLS-26W-E)

Unit : mm

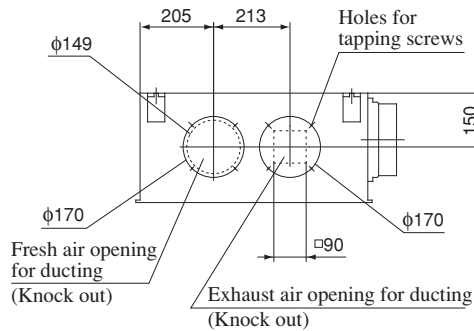
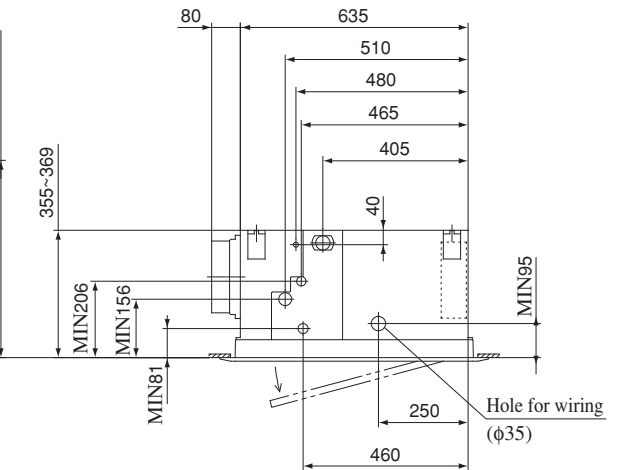
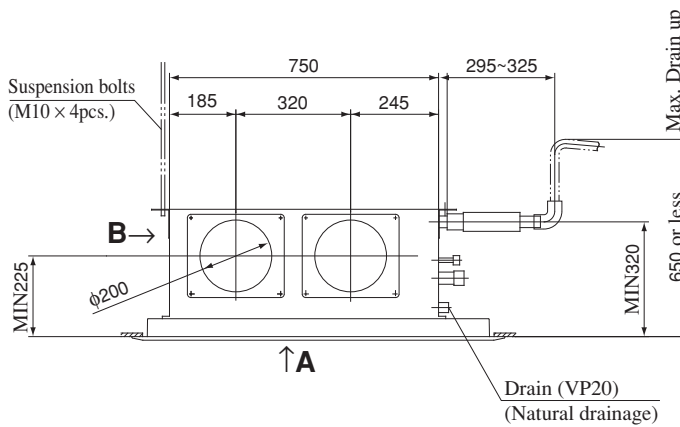
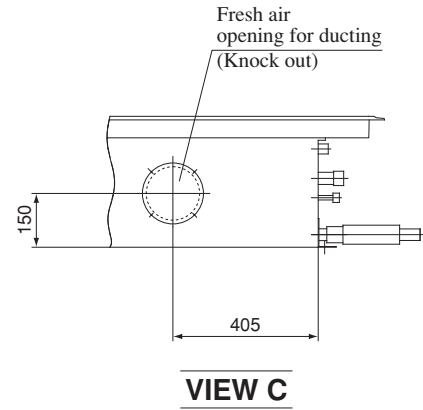
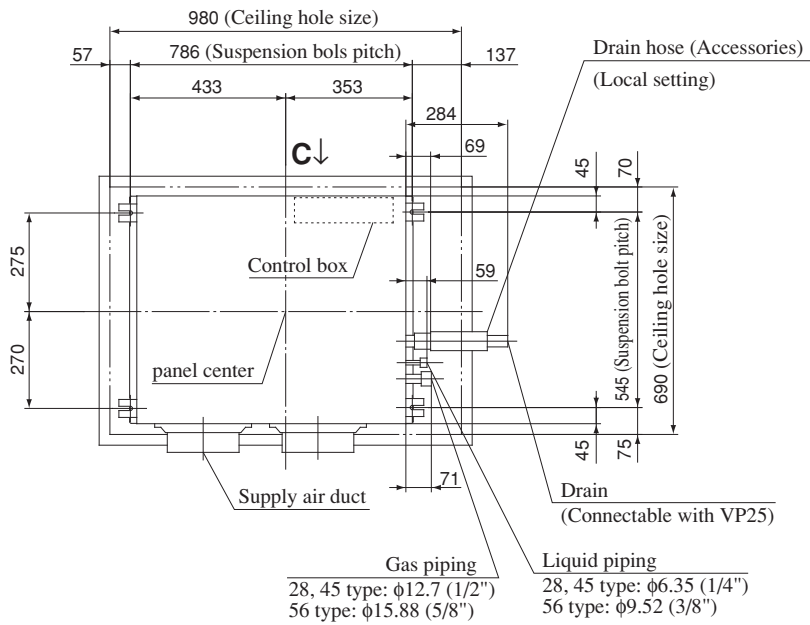

VIEW B

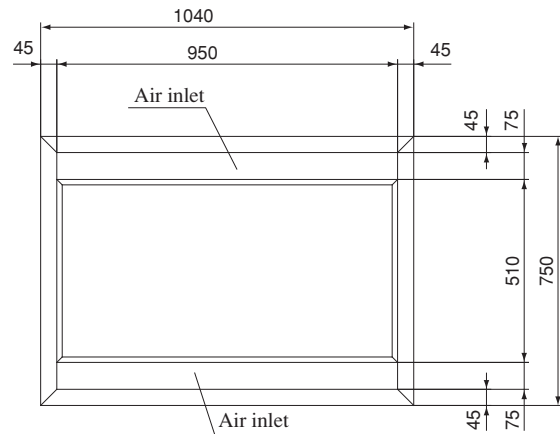

VIEW A

Space for installation and service

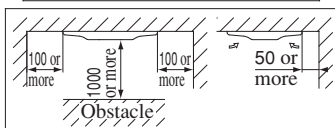

Models FDRJ28HKXE2, 45HKXE2, 56HKXE2

Canvas Panel (Model: R-PNLC-26W-E)

Unit : mm

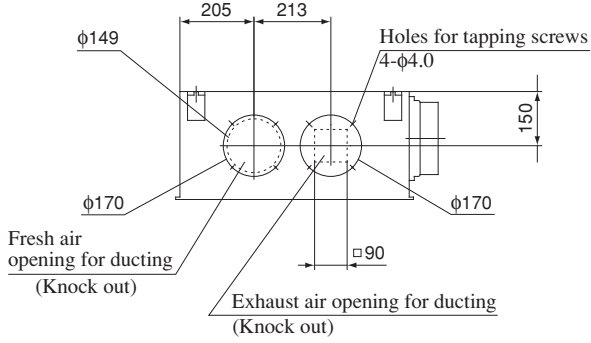
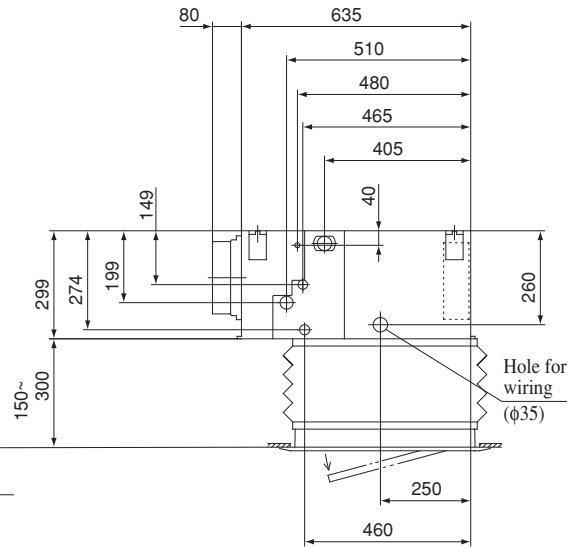
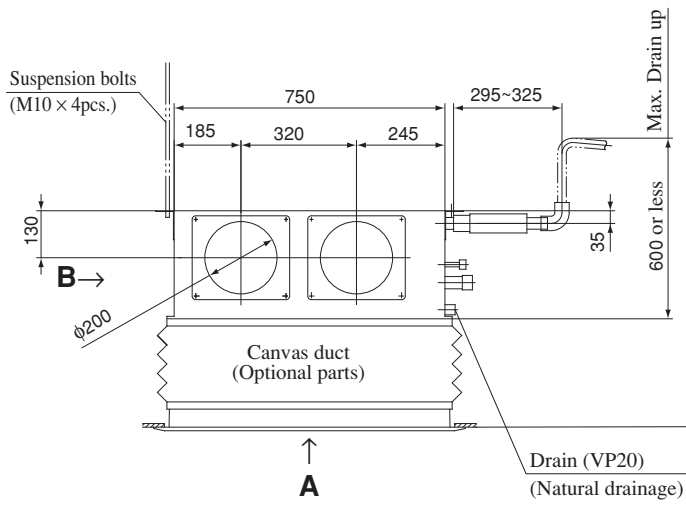
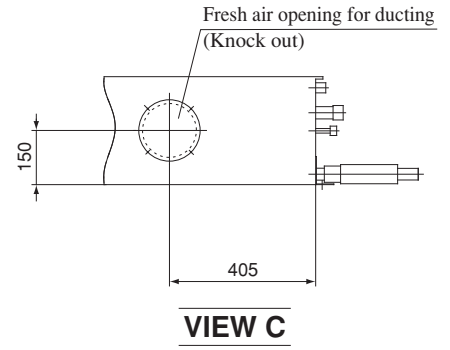
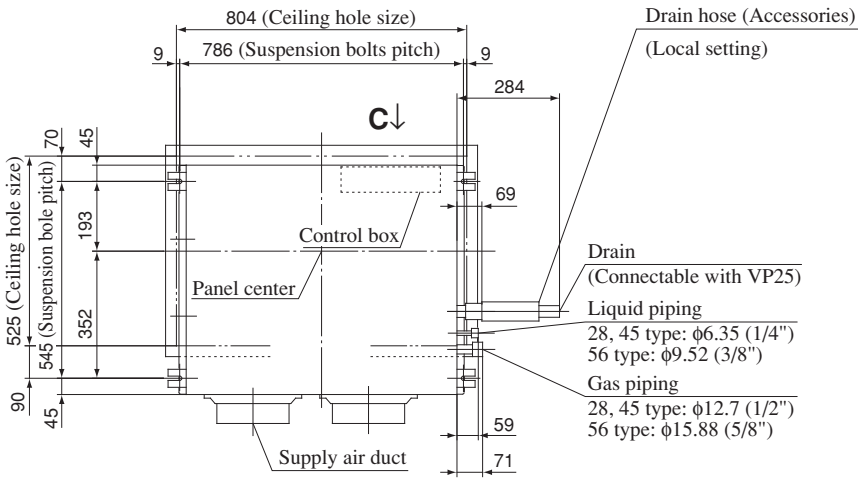

VIEW B

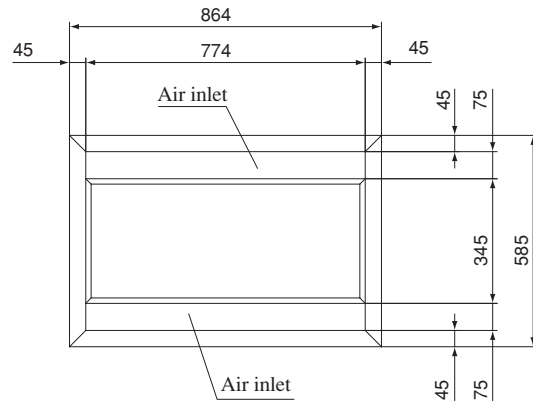

VIEW A

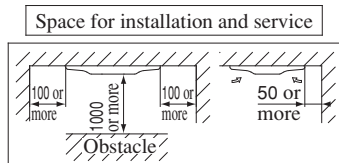

Models FDRJ71HKXE2, 90HKXE2

Silent Panel (Model: R-PNLS-36W-E)

Unit : mm

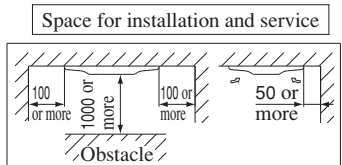
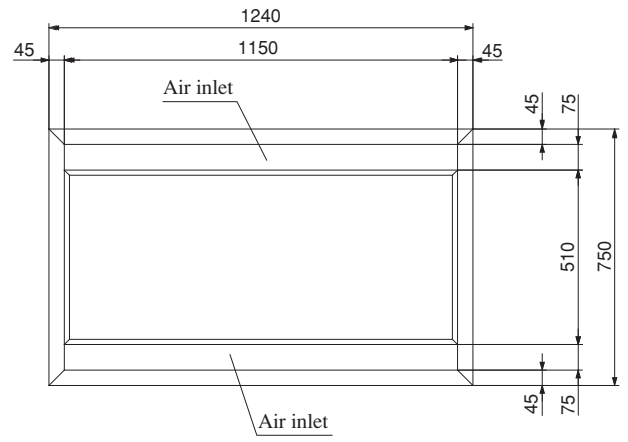
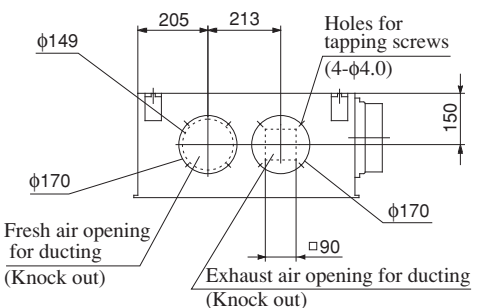
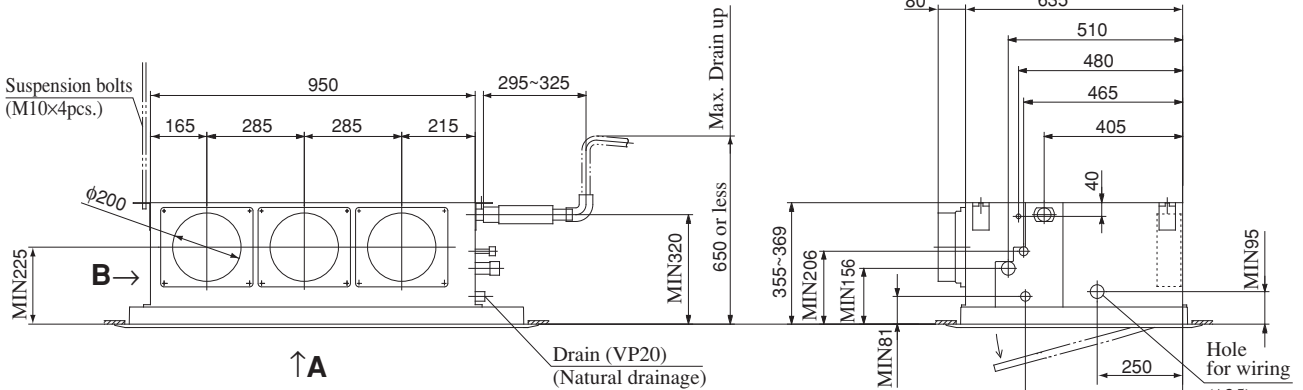
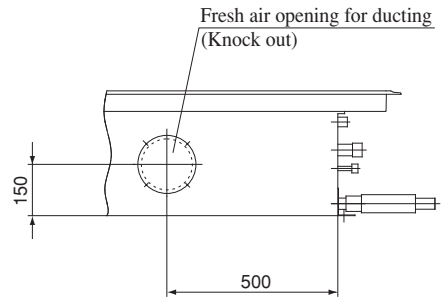
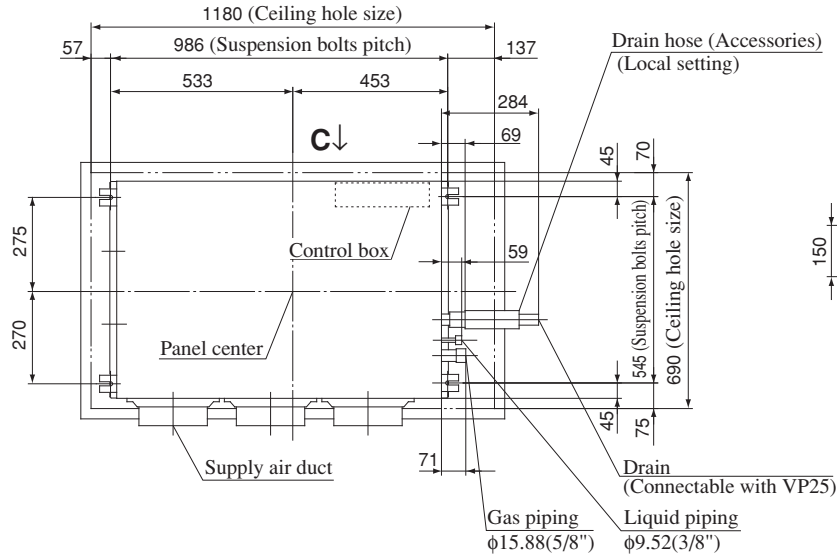

Models FDRJ71HKXE2, 90HKXE2

Canvas Panel (Model: R-PNLC-36W-E)

Unit : mm

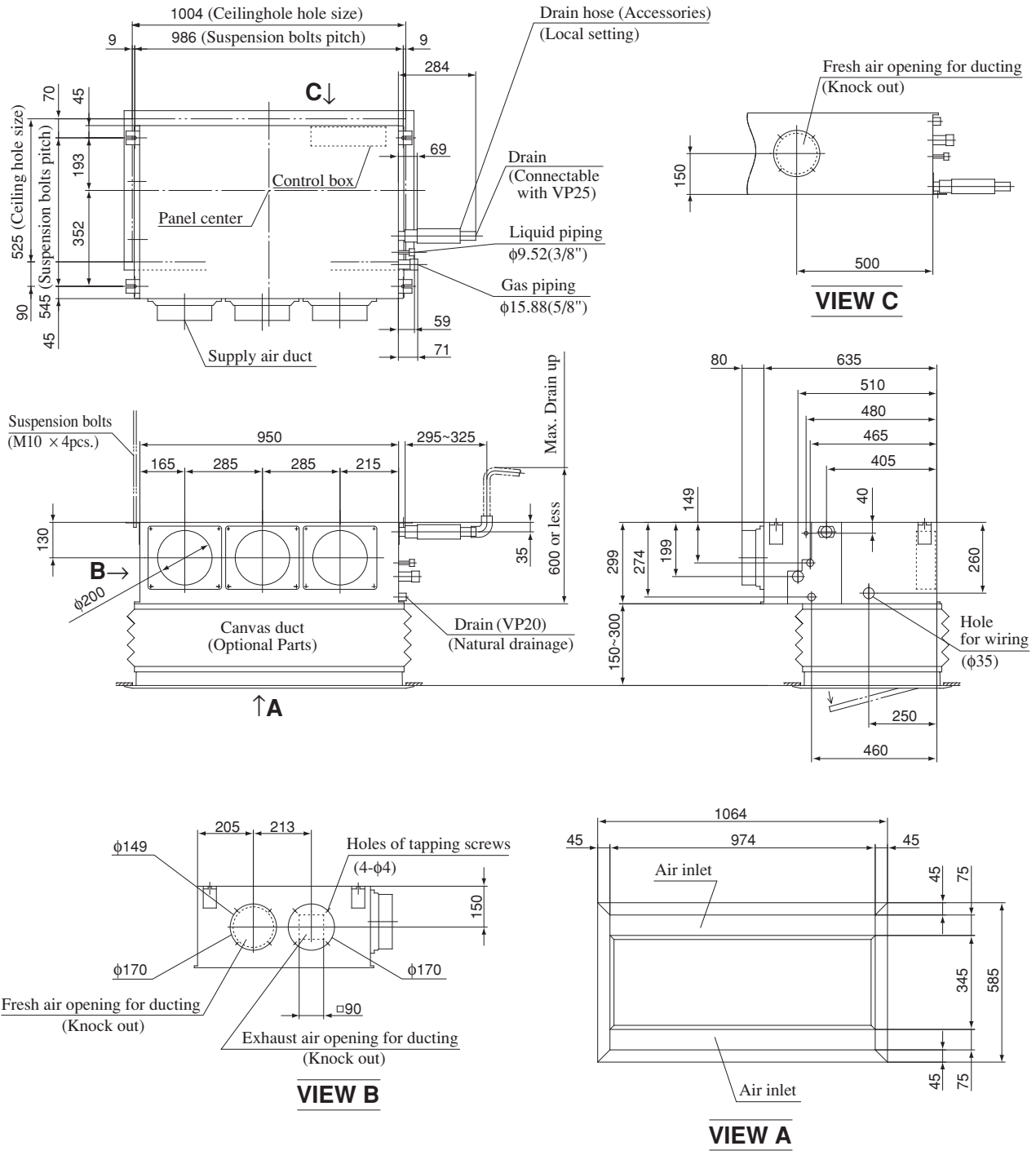

Space for installation and service

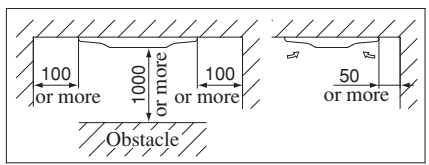

Models FDRJ112HKXE2, 140HKXE2

Canvas Panel (Model: R-PNLC-46W-E)

Unit : mm

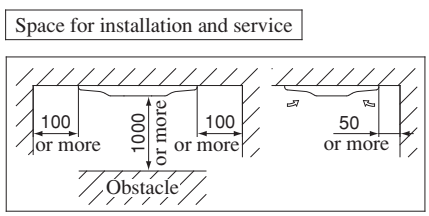
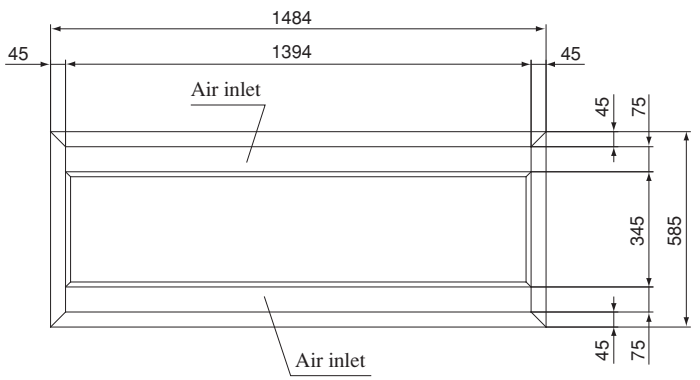
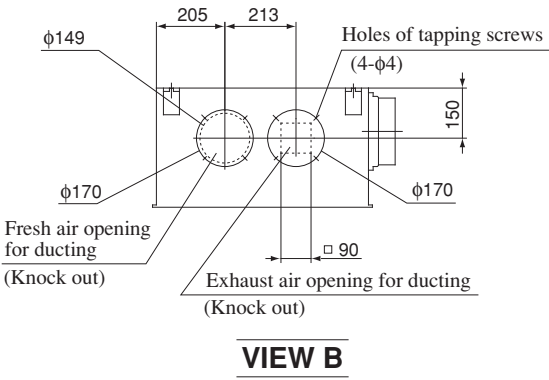
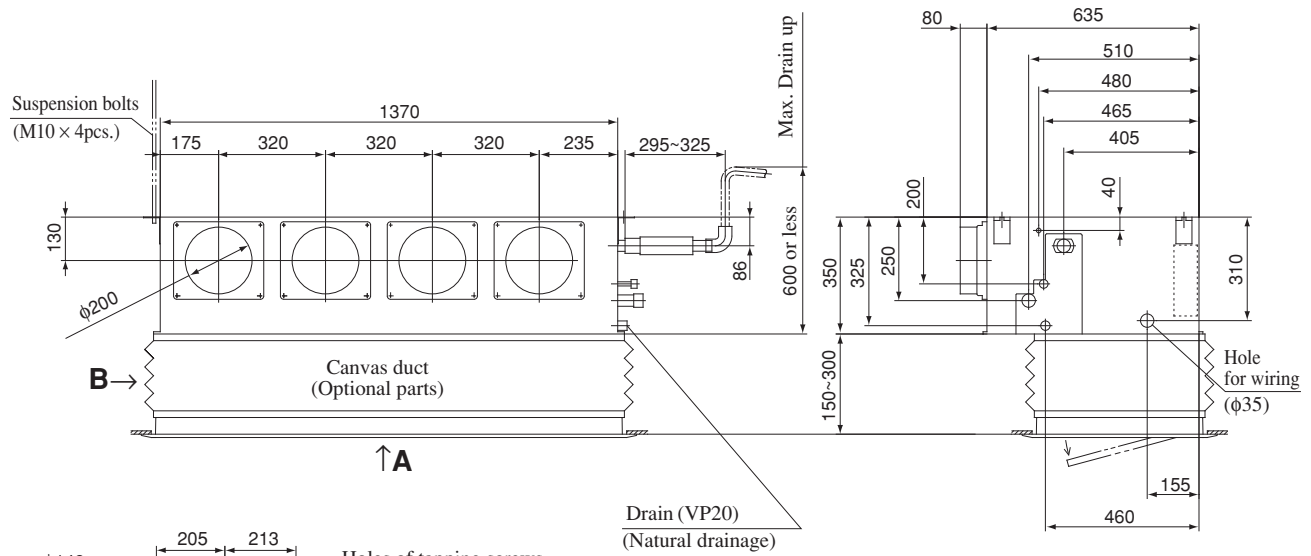
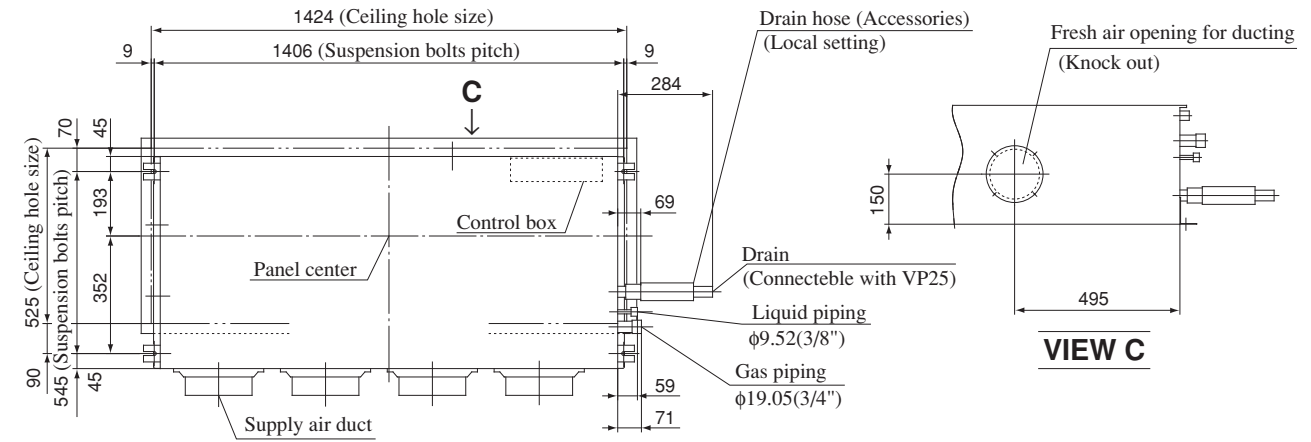

VIEW A

(e) Satellite ducted type (FDUM)

Models FDUMJ36HKXE2, 45HKXE2, 56HKXE2

Unit : mm

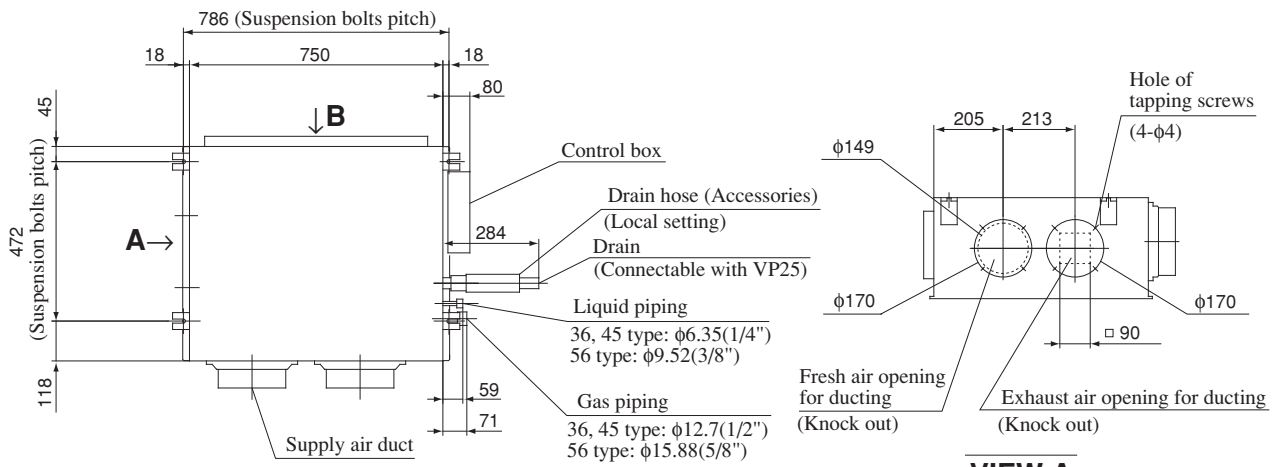

VIEW A

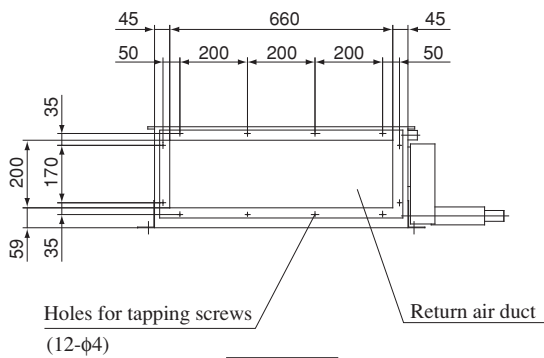
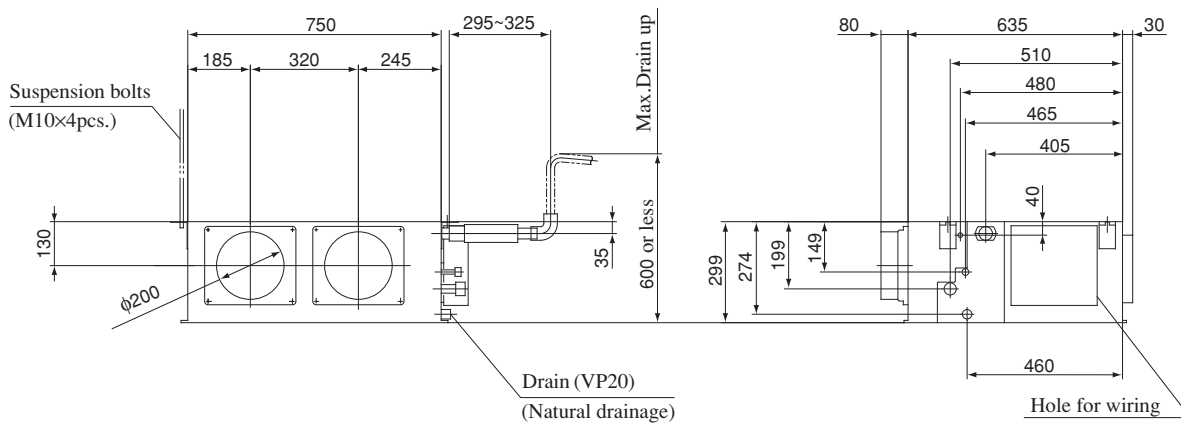

VIEW B

Space for installation and service

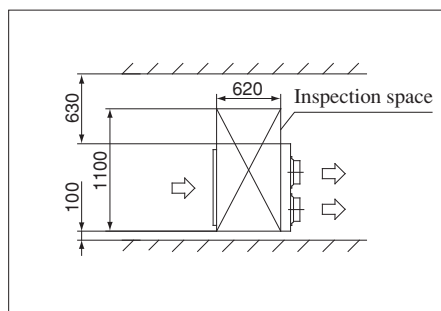

Models FDUMJ71HKXE2, 90HKXE2

Unit : mm

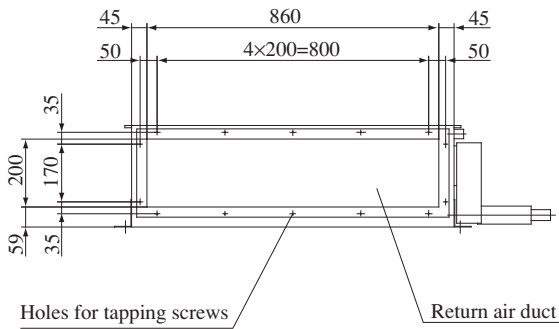
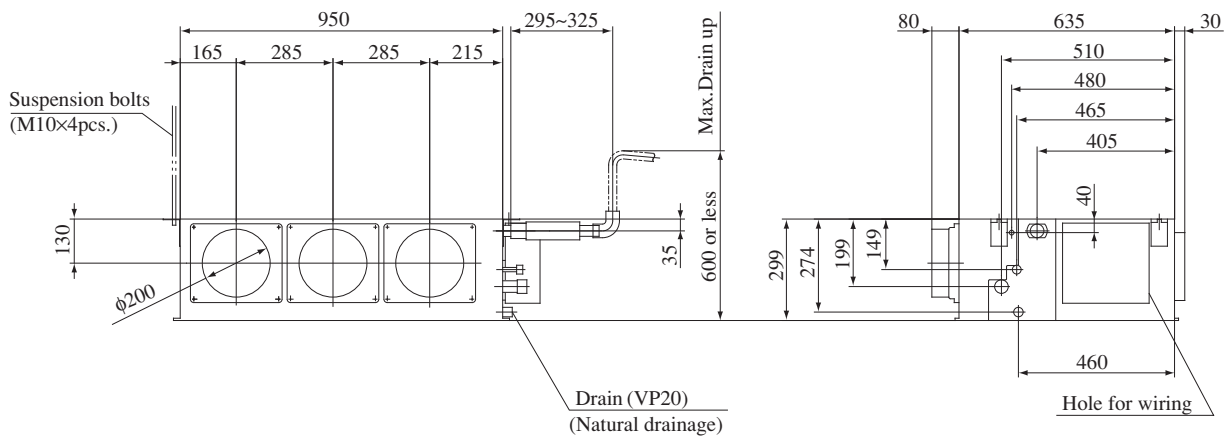
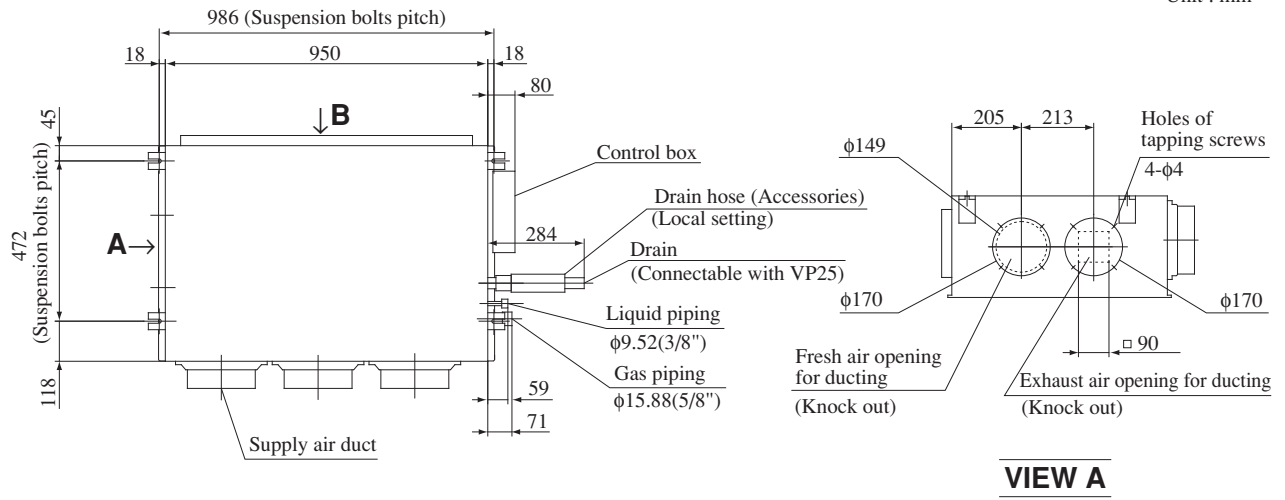

VIEW B

Space for installation and service

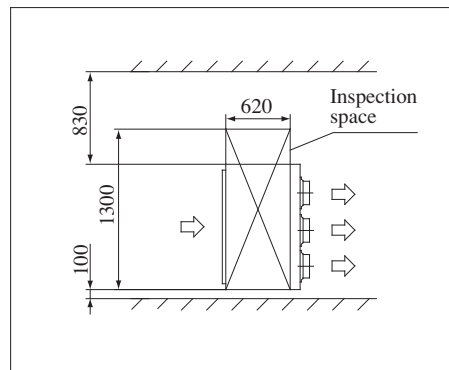

Models FDUMJ112HKXE2, 140HKXE2

Unit : mm

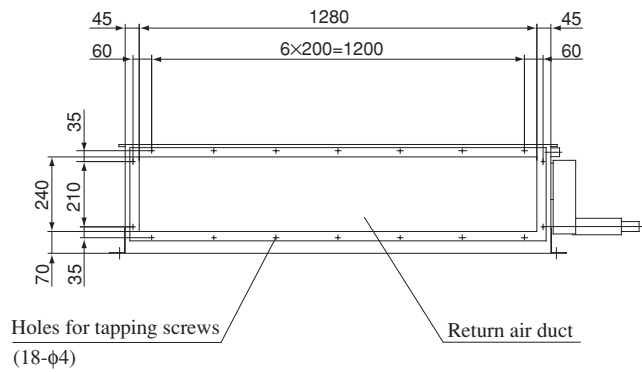
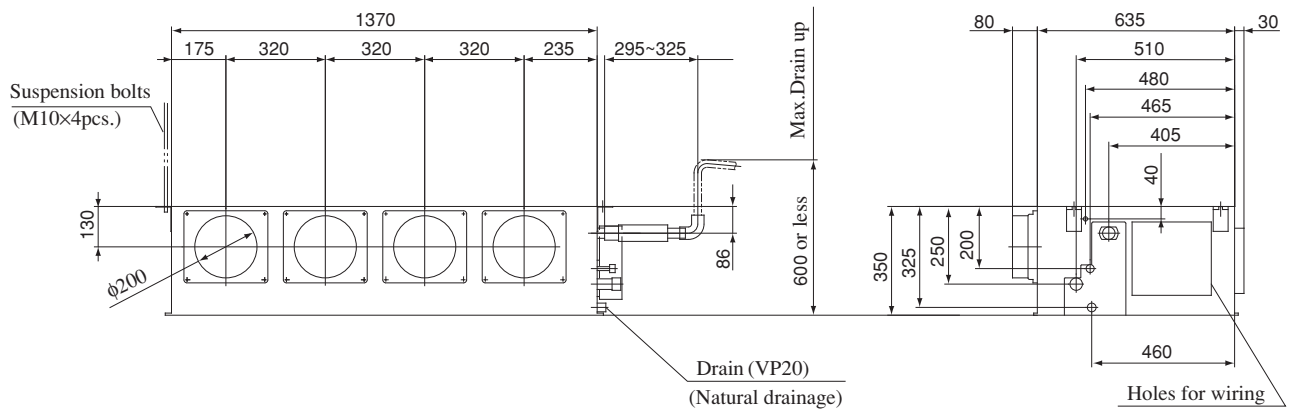
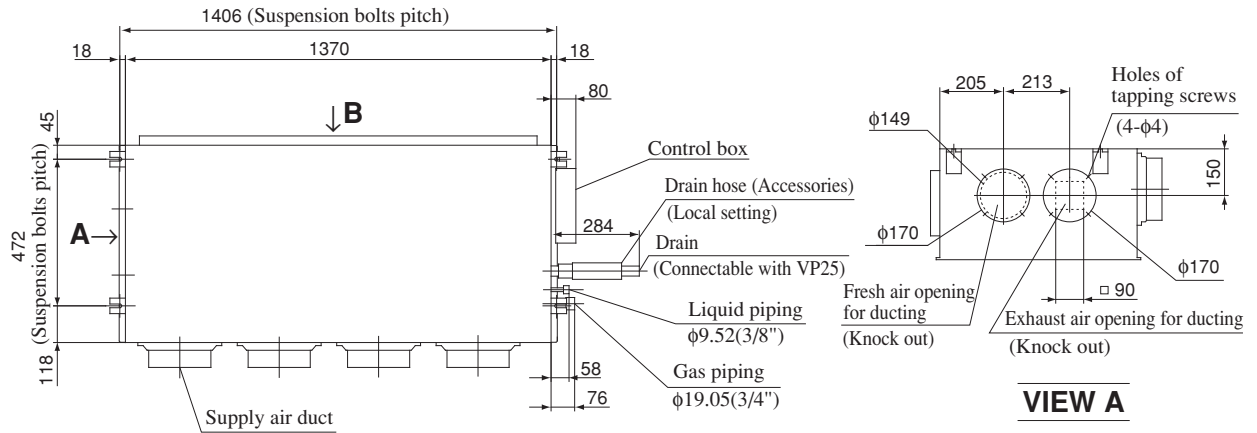

VIEW B

Space for installation and service

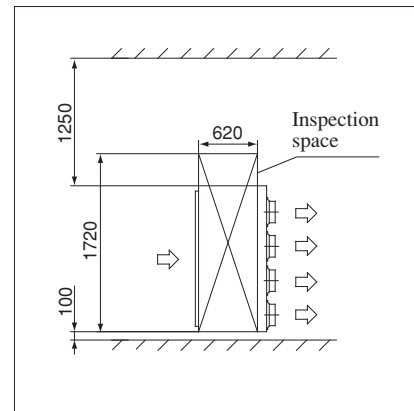

(f) Ceiling suspension type (FDE)

Models FDEJ36HKXE2B, 45HKXE2B, 56HKXE2B

Unit : mm

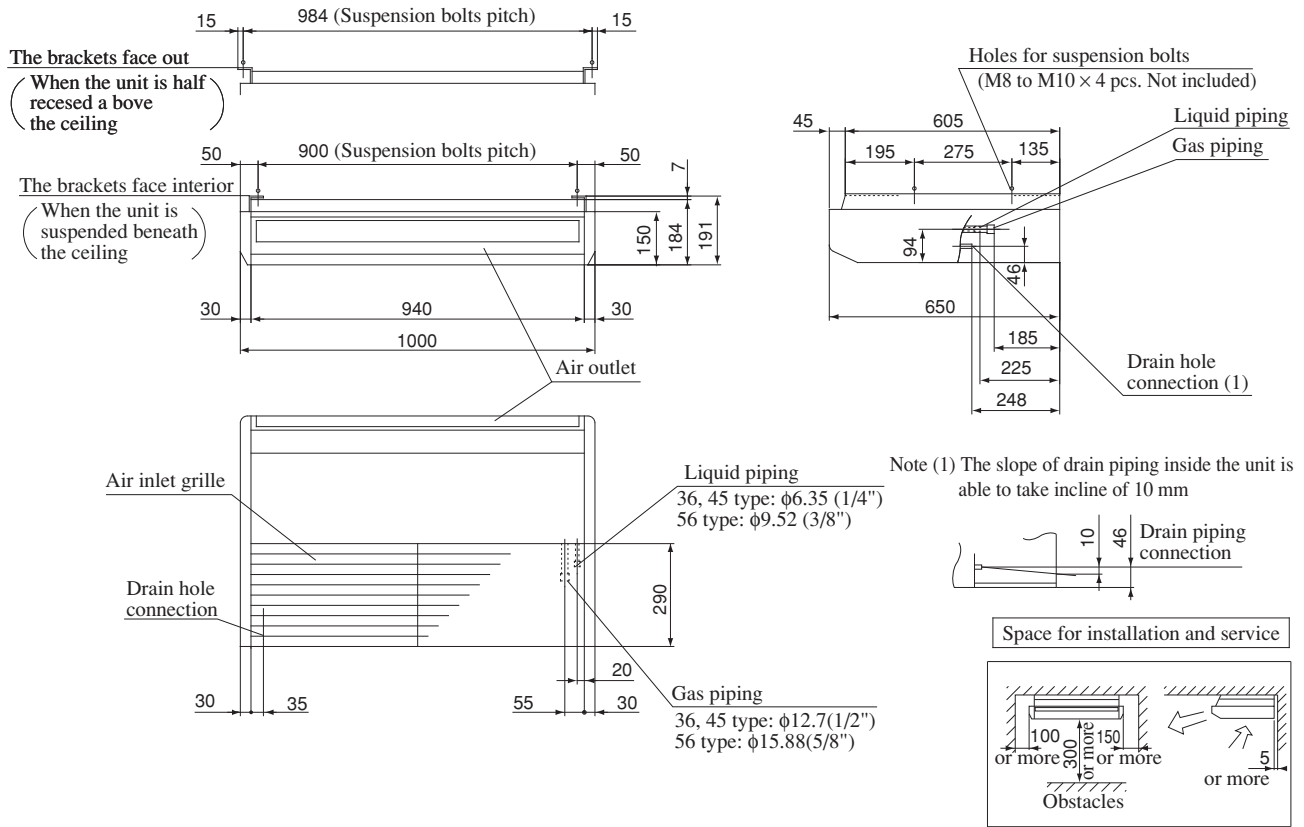

Model FDEJ71HKXE2B

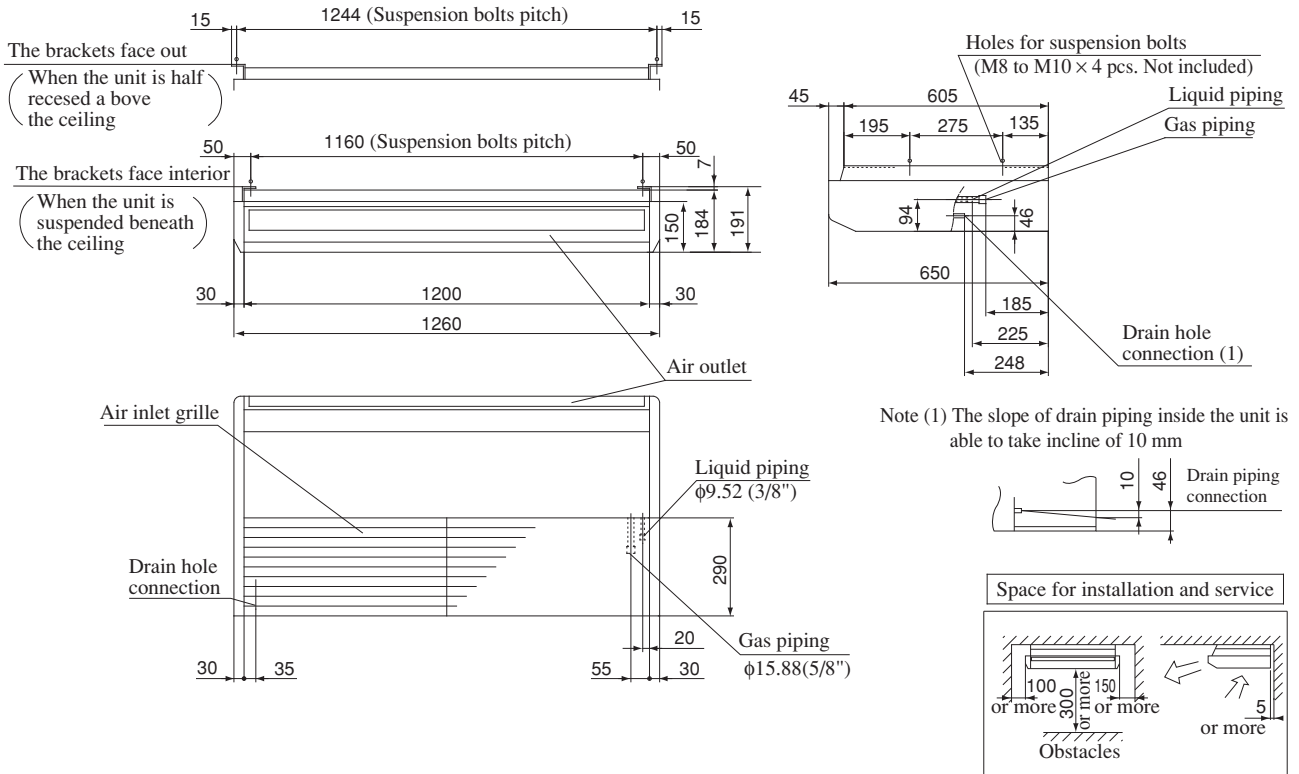

Model FDEJ112HKXE2B

Unit : mm

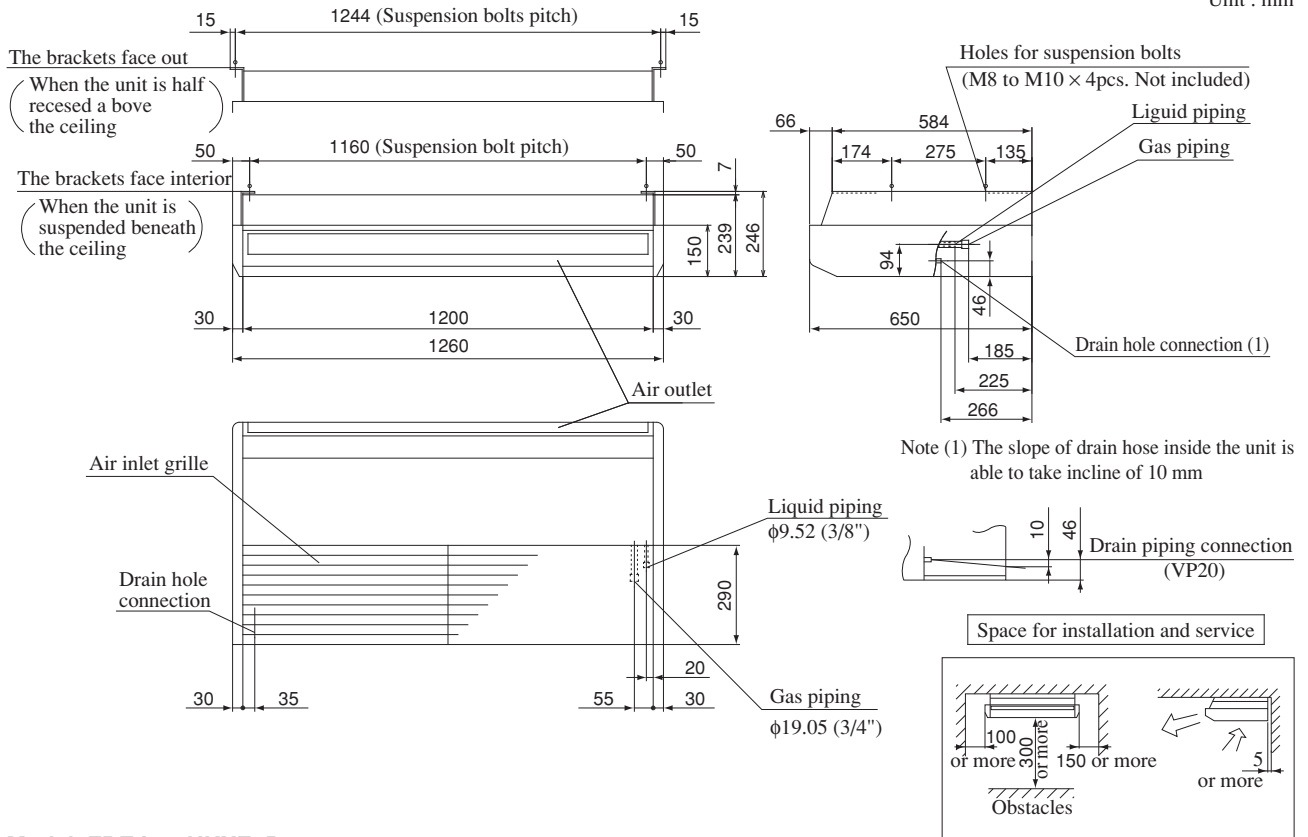

Model FDEJ140HKXE2B

Unit : mm

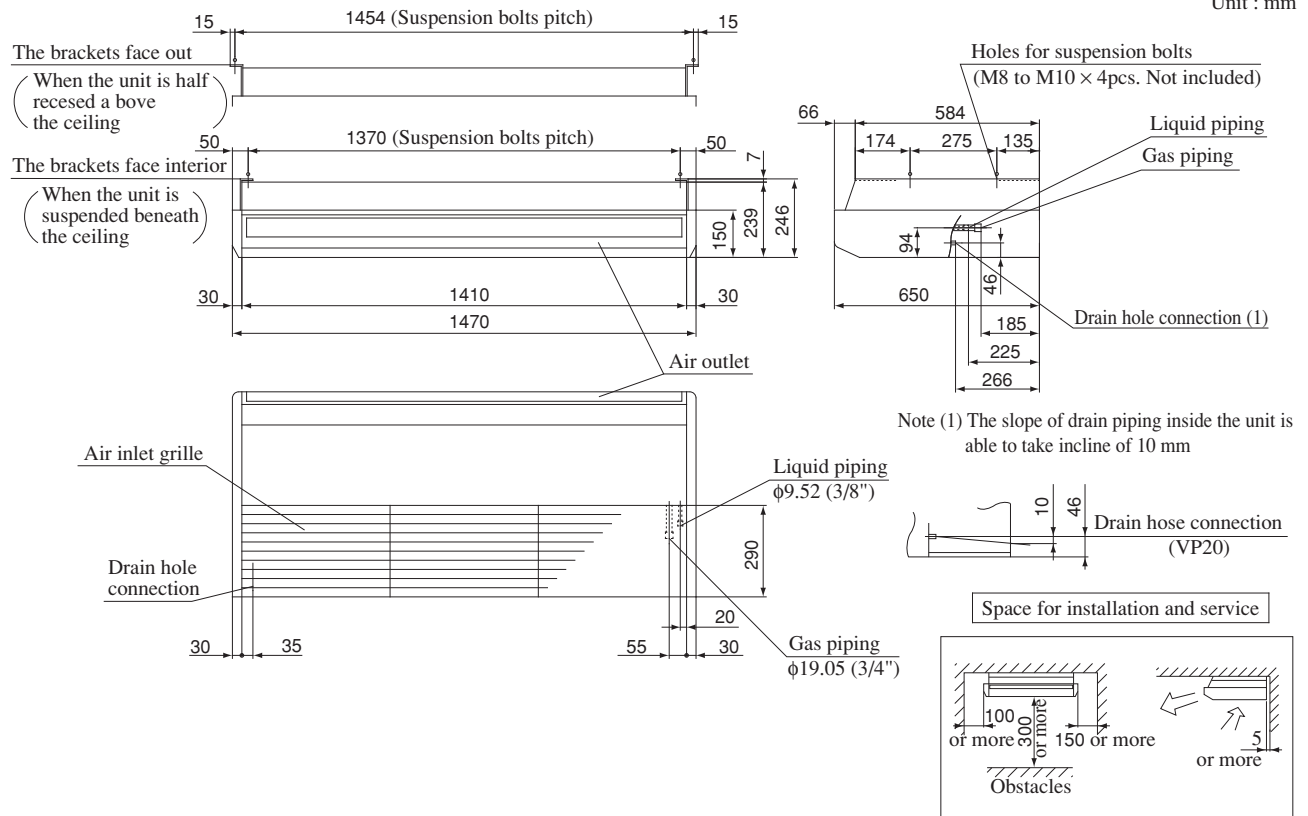

(g) Wall mounted type (FDK)

Models FDKJ22HKXE2, 28HKXE2, 36HKXE2, 45HKXE2

Unit : mm

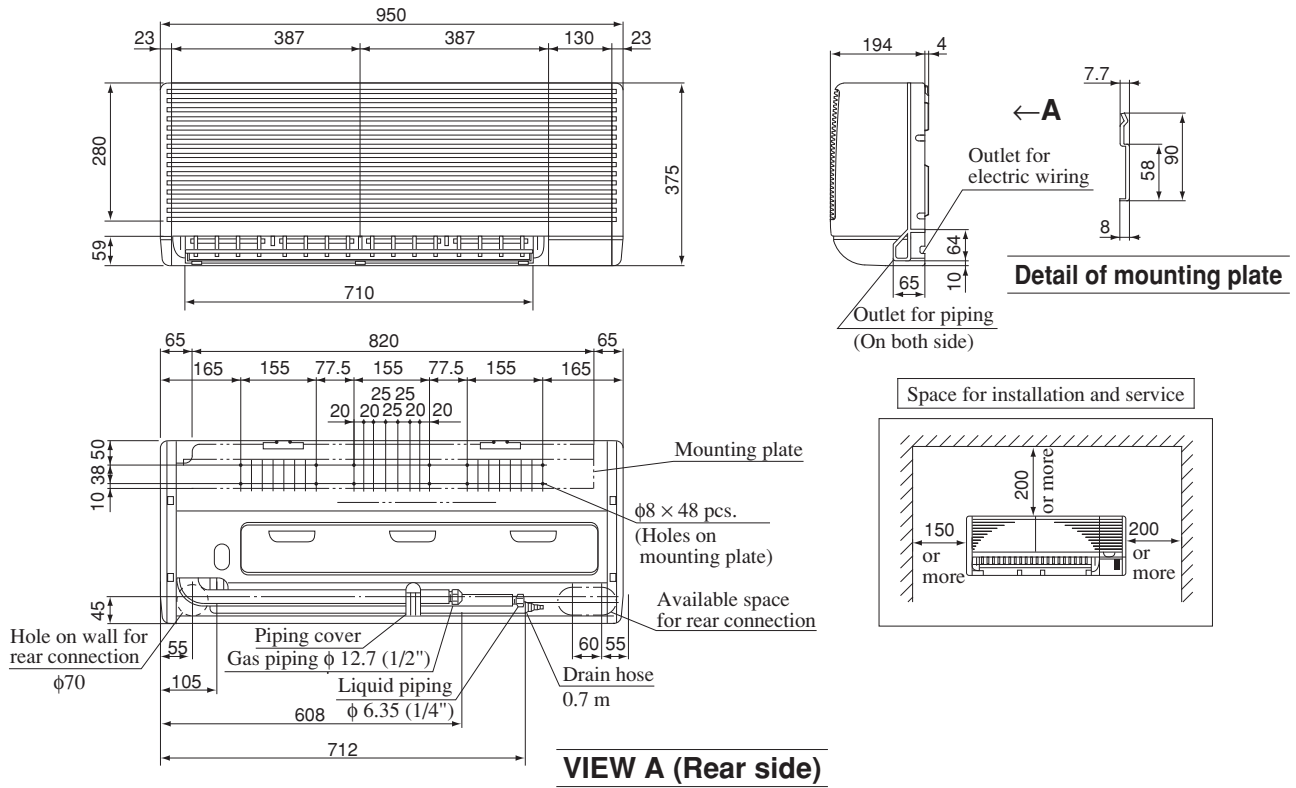

Model FDKJ56HKXE2

Unit : mm

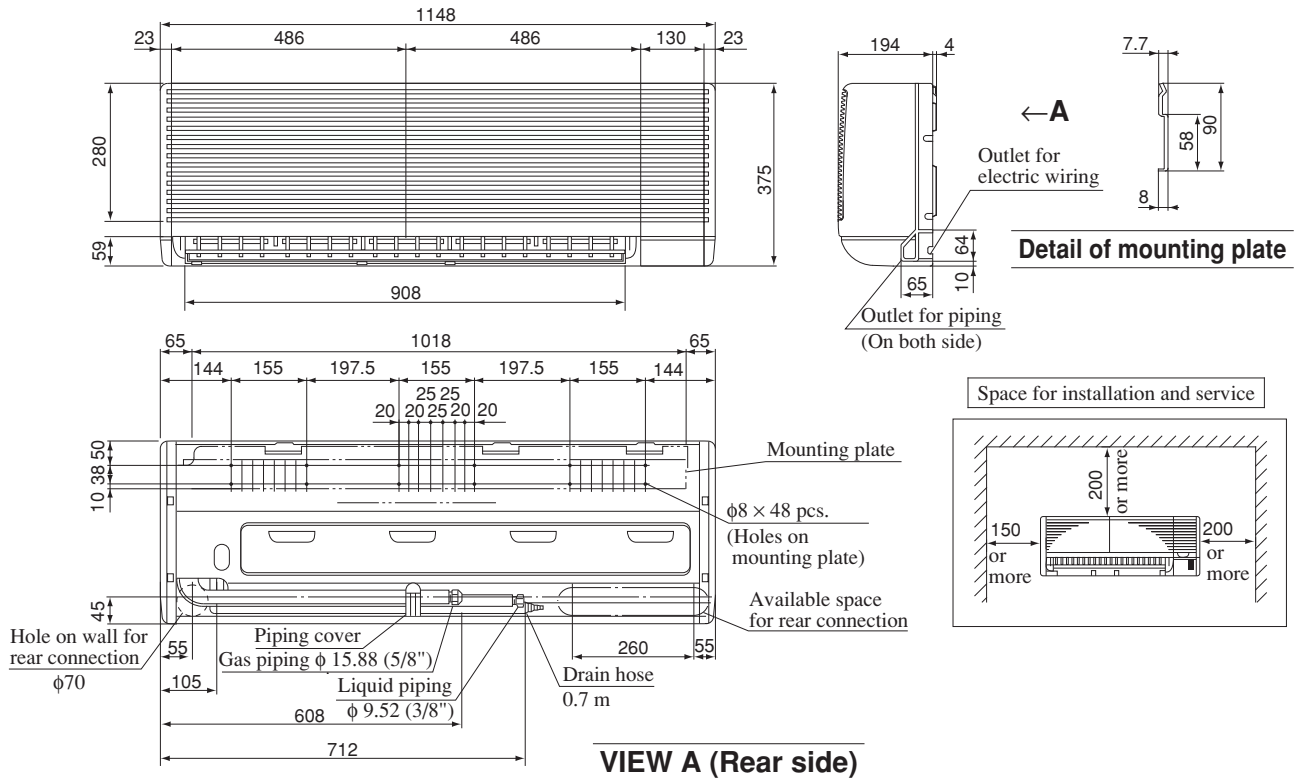

Model FDKJ71HKXE2

Unit : mm

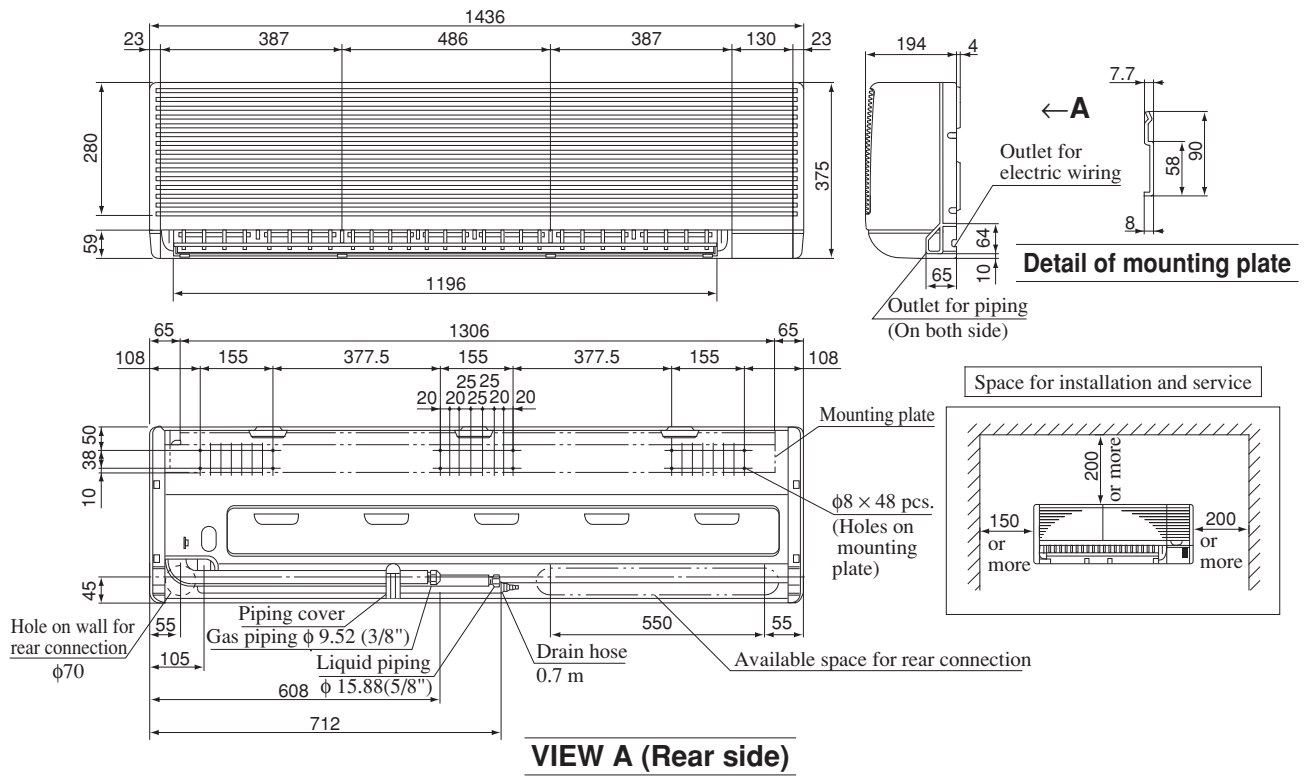

(h) Floor standing exposed type (FDFL)

Models FDFLJ28HKXE2, 45HKXE2, 71HKXE2

Note (1) Value in () indicates 71 type.

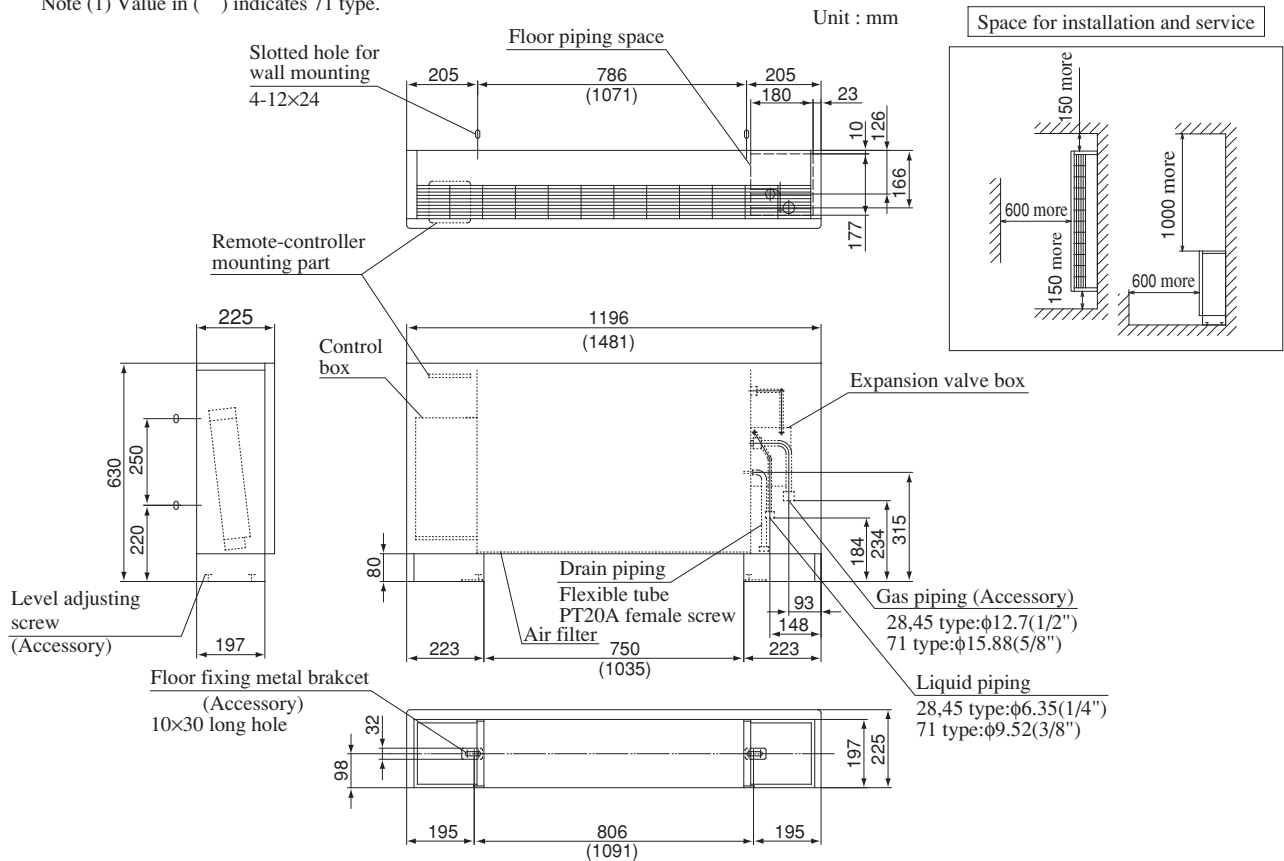

(i) Floor standing hidden type (FDU)

Models FDFUJ28HKXE2, 45HKXE2, 56HKXE2, 71HKXE2

Unit : mm

Note (1) Value in () indicates 71 type.

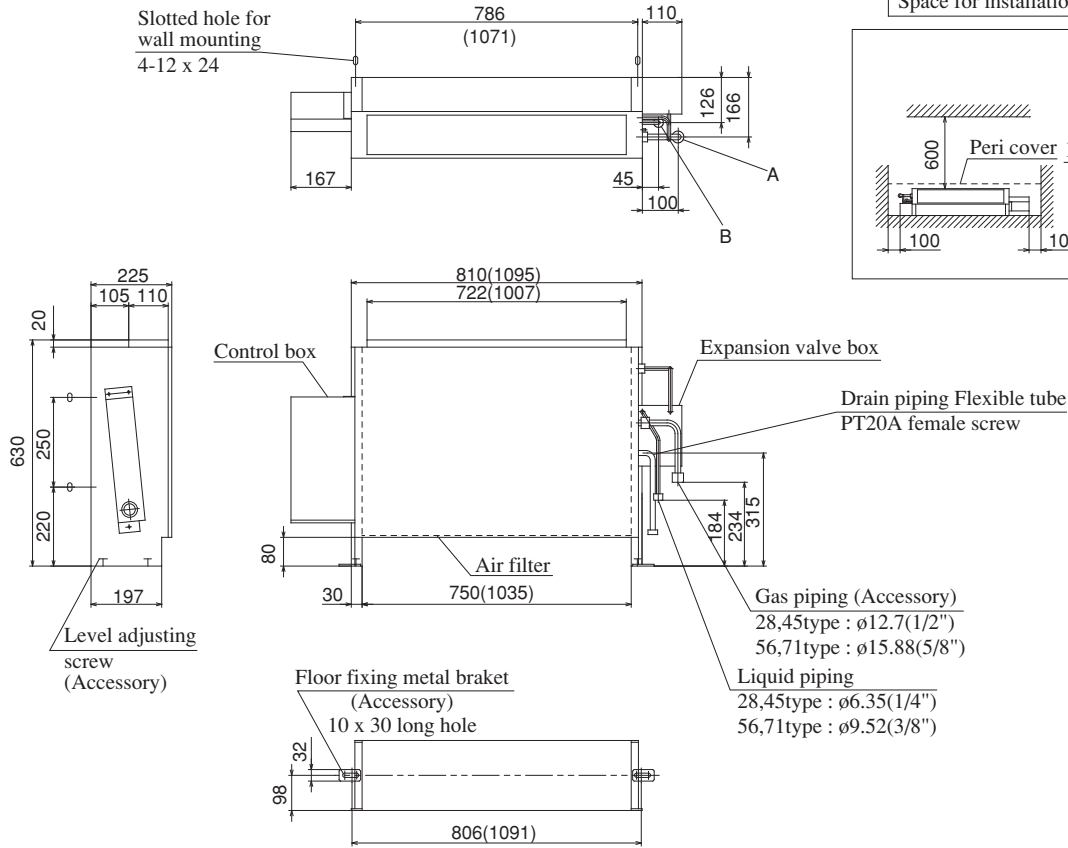

(2) Remote controller (Optional parts)

Unit: mm

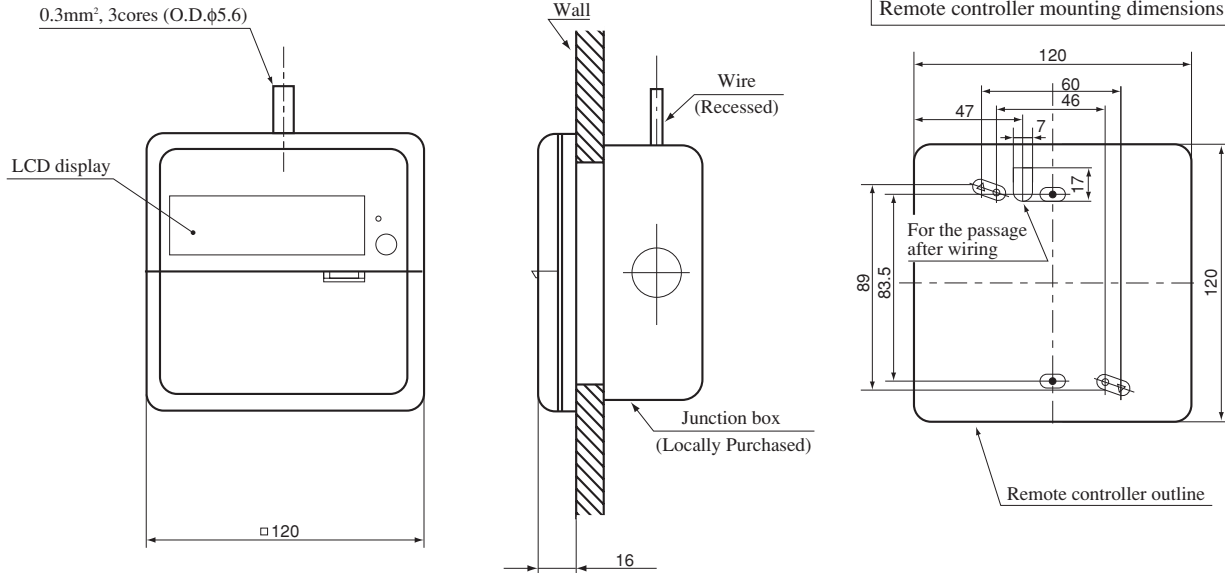

- ◆ Usable JIS box, JIS C 8336
 - Switch box for 1 piece (without cover)
(use of the ● mark hole as illustrated on the left)
 - Switch box for 2 pieces
(use of the ○ mark hole as illustrated on the left)
(without cover)
(use of the △ mark hole as illustrated on the left)
(when installing the cover)

Allowable rang of wire thickness and length

Standard	Within	0.3 mm ²	×	Within	100 m
		0.5 mm ²	×	Within	200 m
		0.75 mm ²	×	Within	300 m
		1.25 mm ²	×	Within	400 m
		2 mm ²	×	Within	600 m

(3) Outdoor unit

**Models FDCP140HKXE2B
FDCJ140HKXE2B**

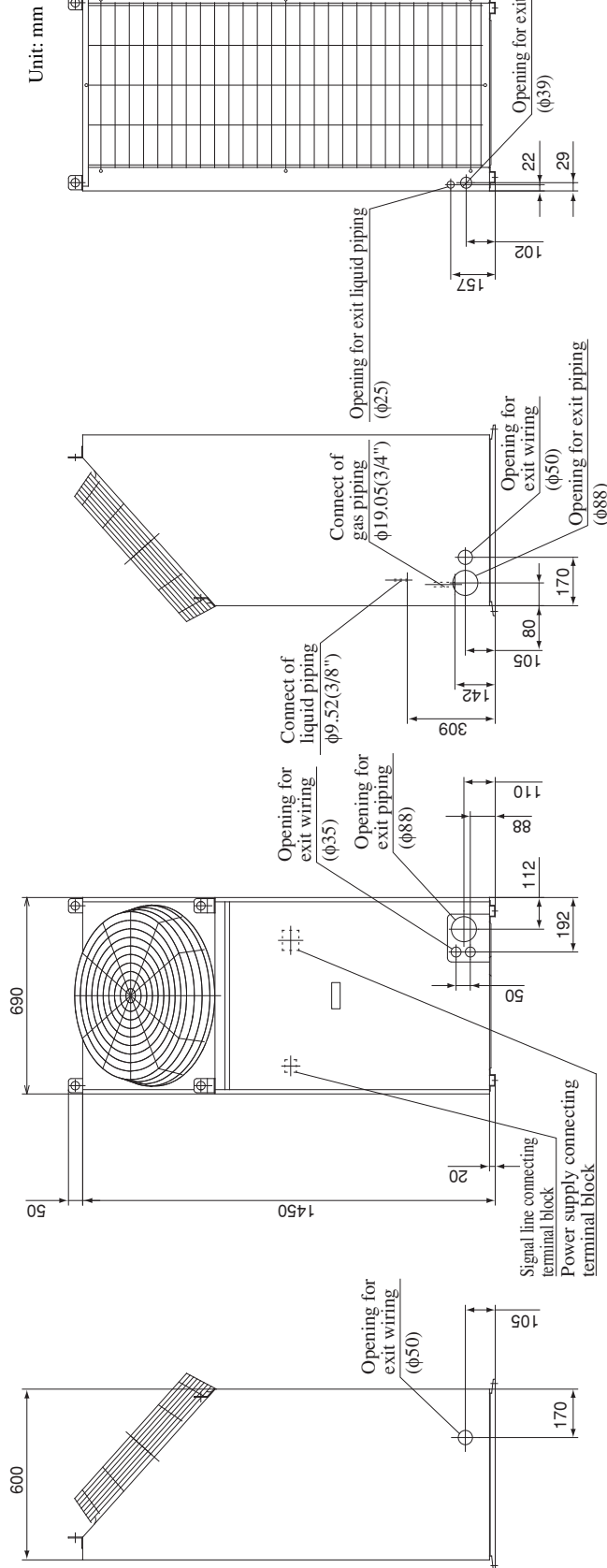

(Unit: mm)

Installation example	I	II	III
L1	Open	Open	500
L2	0	0	0
L3	300	300	300
L4	Open	500	0
H1	—	—	1000 or less
H2	Not limited	Not limited	Not limited
H3	Not limited	Not limited	700 or less
H4	—	Not limited	Not limited

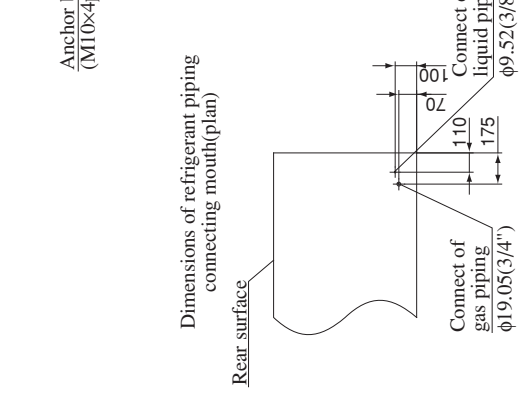
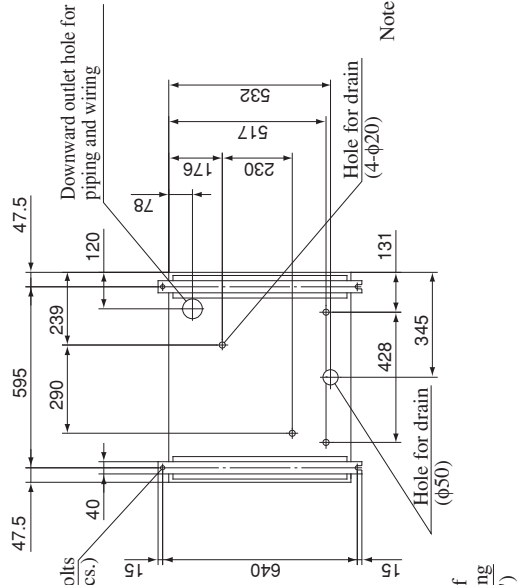
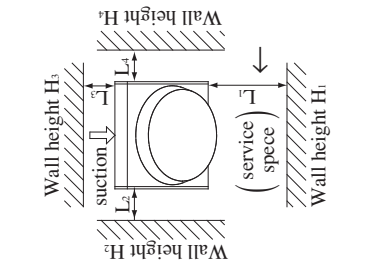

- Notes
- (1) Make sure to secure the unit with anchor bolts.
 - (2) When the strong wind blows, place the unit so that discharge outlet faces the wind direction with right angle.
 - (3) Make sure to allow the space of 1 m or more above the unit.
 - (4) Connect the refrigerant piping (both gas side and liquid side) at local site.
 - (5) If the wall height H₁, H₃ of installation example III exceeds the limited value, make sure the value of L₁, L₃ are to be as follows.
L₁ = H₁ - 500
L₃ = 300 + (H₃ - 700) / 2, however, if L₃ exceeds 600, there is no limit for the wall height H₃.