



# Package Air Conditioner **SERVICE MANUAL**

**MODEL: LP-10091CL/XL  
LP-15091CL/XL  
LP-20091CL/XL**



# CONTENTS

---

<b>1. Preface</b> .....	<b>3</b>
<b>2. Dimensions</b> .....	<b>7</b>
<b>3. Refrigerant Cycle Diagram</b> .....	<b>8</b>
<b>4. Wiring Diagram</b> .....	<b>9</b>
<b>5. Operation Details</b> .....	<b>17</b>
<b>6 Installation</b> .....	<b>20</b>
<b>7. 3-Way Valve</b> .....	<b>33</b>
<b>8. Troubleshooting Guide</b> .....	<b>40</b>
<b>9. Electronic Control Device</b> .....	<b>53</b>
<b>10. Schematic Diagram</b> .....	<b>55</b>
<b>11. Exploded View &amp; Replacement Parts List</b> .....	<b>56</b>

# 1. PREFACE

---

This service manual provides various service information, containing the mechanical and electrical parts and etc. This package air conditioner was manufactured and assembled under the strict quality control system. The refrigerant is charged at the factory. Be sure to read the safety precautions prior to servicing the unit.

## 1.1 Safety Precautions

1. When servicing the unit, set the main SWITCH to OFF and remove the POWER SUPPLY cables.
2. Observe the original lead dress. If a short circuit is found, replace all parts which have been overheated or damaged by the short circuit.
3. After servicing the unit, make an insulation resistance test to protect the customer from being exposed to shock hazards.

## 1.2 Features

1. Design for cooling
2. Super energy efficiency
3. Removable air filter
4. 3 minute delay circuit
5. Child Lock function (LP-10091CL/XL, 15091CL/XL)
7. Micom Control (LP-10091CL/XL, 15091CL/XL)
8. 7 hour timer (LP-10091CL/XL, 15091CL/XL)

## 1.3 Product Specifications

ITEMS		MODEL	LP-10091CL	LP-10091XL	LP-15091CL	LP-15091XL	LP-20091CL	LP-20091XL
		UNIT						
POWER SUPPLY		Ø, V, Hz	3,220/380, 60		3,220/380, 60		3,220/380, 60	
COOLING CAPACITY		Btu/hr	100,000		150,000		200,000	
ELECTRIC HEATER CAPACITY		KW	-	20	-	30	-	40
POWER INPUT	COOLING	W	13,000	13,000	18,500	18,500	24,500	24,500
	E/ HEATER	W	-	20,000	-	30,000	-	40,000
RUNNING CURRENT	COOLING	W	35.4/21	35.4/21	53.5/31	53.5/31	71/43	71/43
	E/ HEATER	W	-	53/35	-	78/46	-	106/61
COMPRESSOR	MODEL		QR12M2-ES8		QR90K2-ES8		QR12M2-ES8	
	MAKER		COPELAND		COPELAND		COPELAND	
	TYPE		RECIPRO		RECIPRO		RECIPRO	
	COOLING CAPACITY	Btu/hr	115,000		91,100		115,000	
	INPUT	(KW)	12,660		9.59		12,660	
	LRA	A	213/123		191/110		213/123	
NOISE LEVEL	INDOOR	dB(A)	60		63		65	
	OUTDOOR	dB(A)	62		65		68	
AIR CIRCULATION	INDOOR	CMM	89		130		150	
	OUTDOOR	CMM	150		150 X 2		150 X 2	
REFRIGERANT (R-22)		kg	6.5		8.0 X 2		7.8 X 2	
HEAT EXCHANGER	INDOOR	R/C/FPI	3/ 33/ 17		4/ 28/ 15		4/ 28/ 15	
	OUTDOOR	R/C/FPI	2/ 36/ 17		2/ 34/ 17		2/ 36/ 17	
FAN	INDOOR	TYPE	SIRCCO					
	OUTDOOR	TYPE	PROPELLER					
ROOM TEMPERATURE CONTROL			MICOM				MANUAL	
D I M E N S I O N S	INDOOR	WIDTH	1,050		1,558		1,558	
		HEIGHT	1,860		1,920		1,920	
		DEPTH	495		700		700	
	OUTDOOR	WIDTH	1,245		1,320		1,245	
		HEIGHT	930		990		930	
		DEPTH	650		650		650	
NET WEIGHT	INDOOR	kg	137	155	200	223	200	234
	OUTDOOR	kg	180		170 x 2		180 x 2	
CONNECTIONS	LIQUID	inch(mm)	1/2		5/8		5/8	
	GAS	inch(mm)	11/10		1		11/10	

# 1.4 Functions

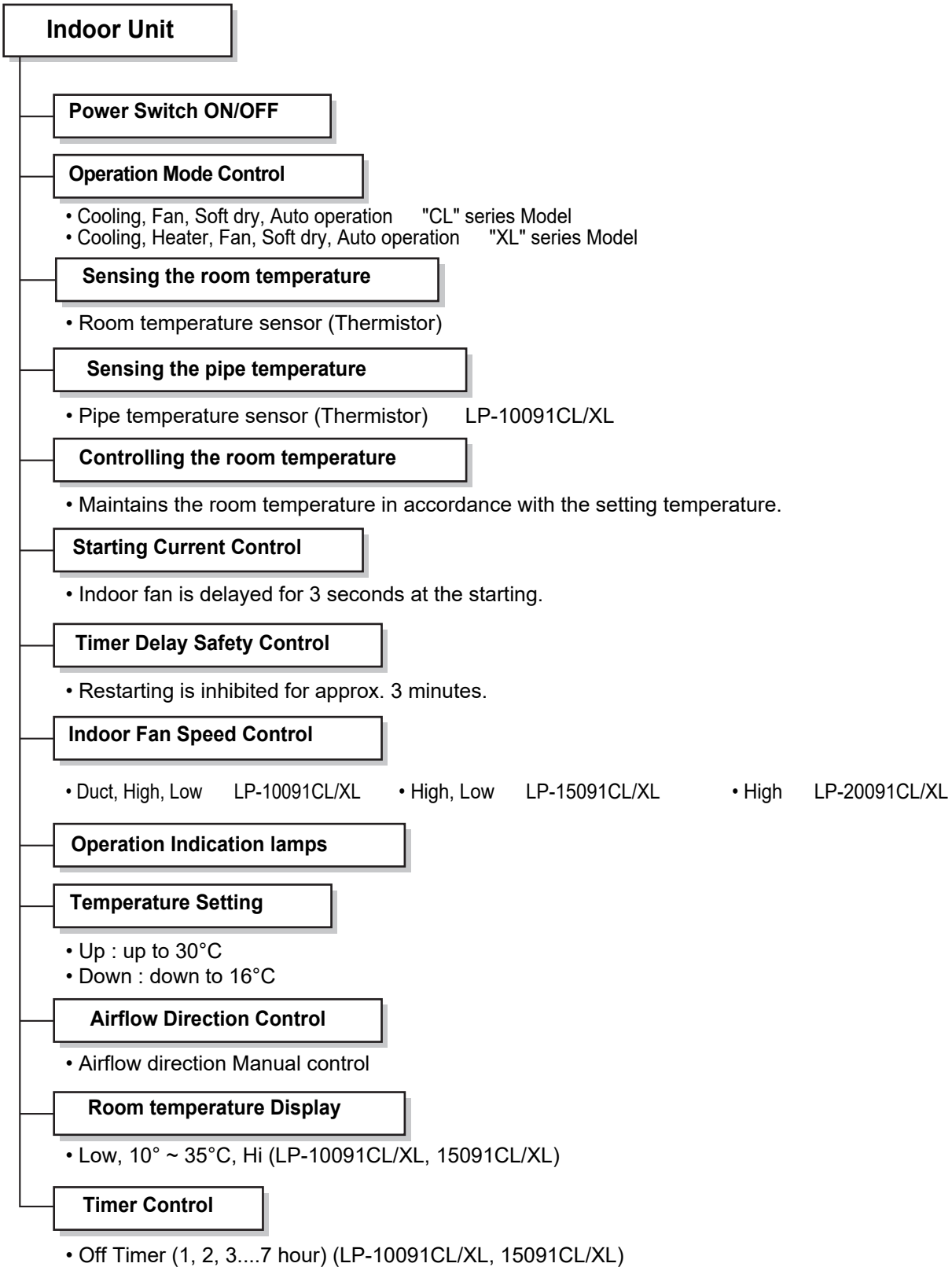

## **Outdoor Unit**

### **Outdoor Fan Speed Control**

- One speed

### **Sensing Discharge Pressure For Compressor**

- Discharge pressure sensor (High Pressure Switch)

### **Sensing Suction Pressure for Compressor**

- Suction pressure sensor (Low Pressure Switch)

# 2. DIMENSIONS

## 2.1 LP-10091CL/XL

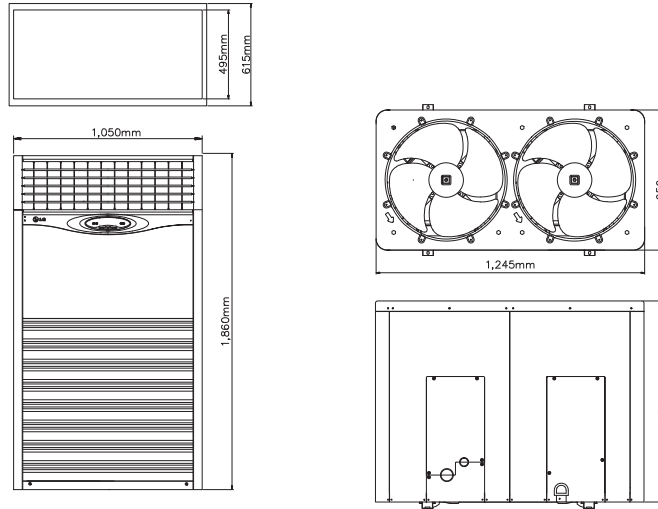

## 2.2 LP-15091CL/XL

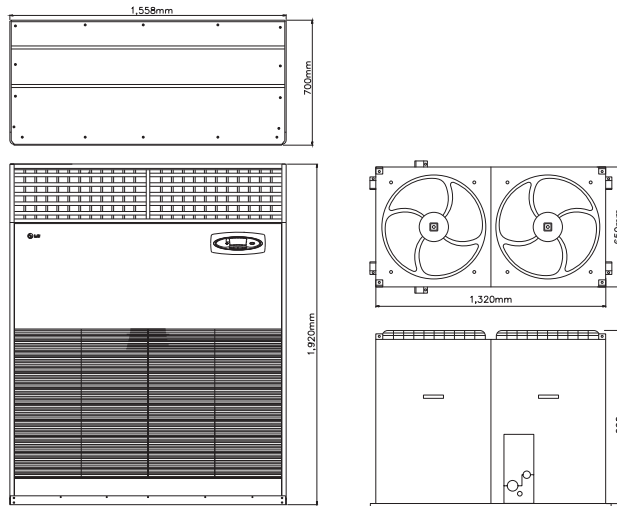

## 2-3 LP-20091CL/XL

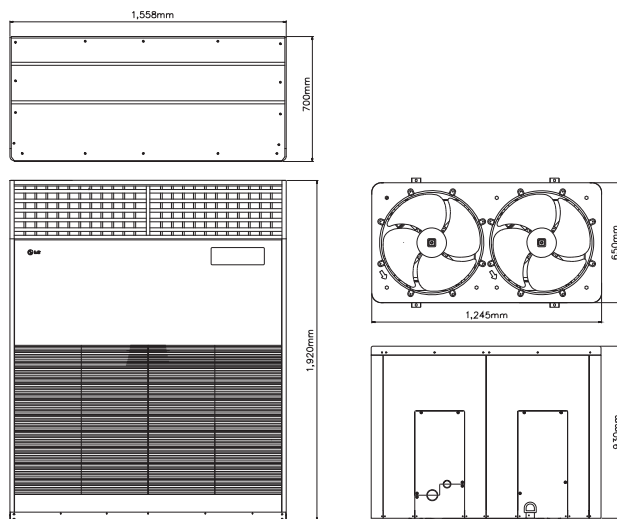

# 3. REFRIGERANT CYCLE DIAGRAM

- Cooling Cycle

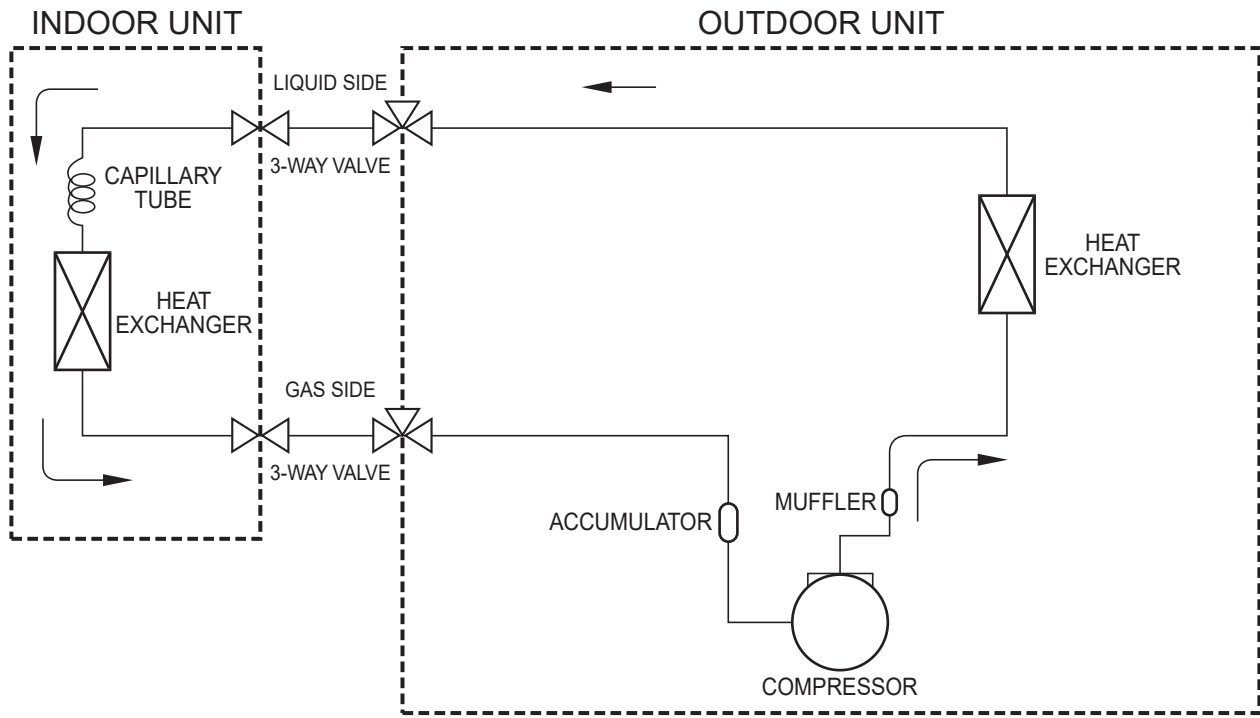



# 4. WIRING DIAGRAM

## 4.1 LP-10091CL

### • INDOOR UNIT

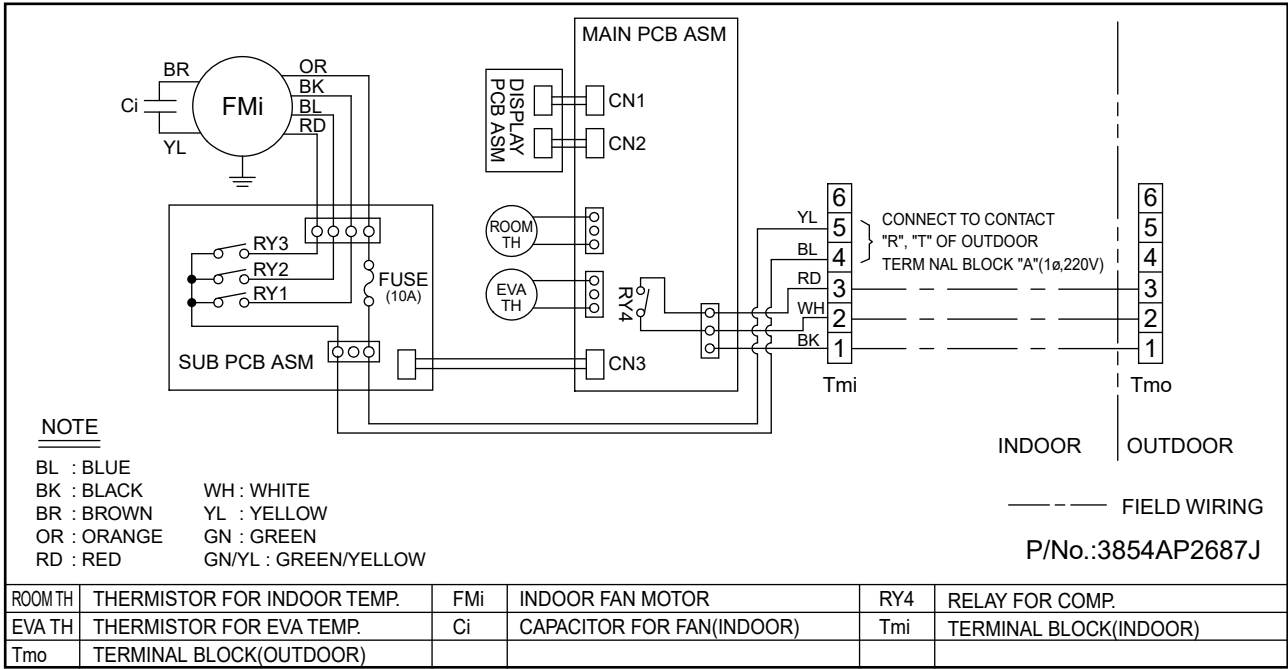

### • OUTDOOR UNIT (LP-10091CL/XL)

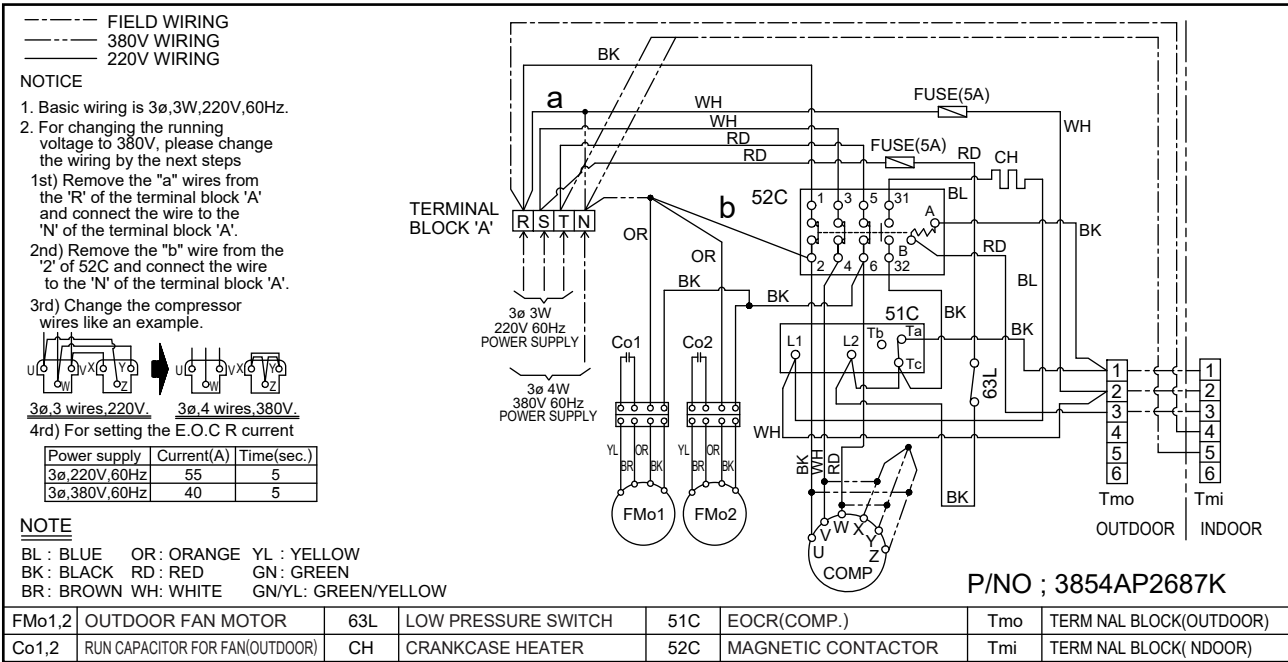

## 4.2 LP-10091XL

### • INDOOR UNIT

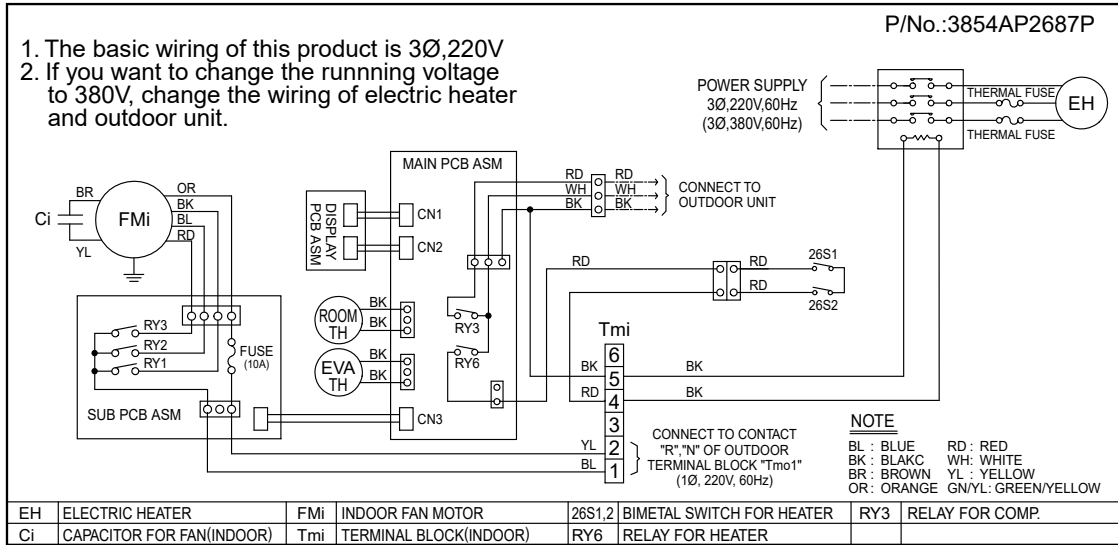

### • ELECTRIC HEATER

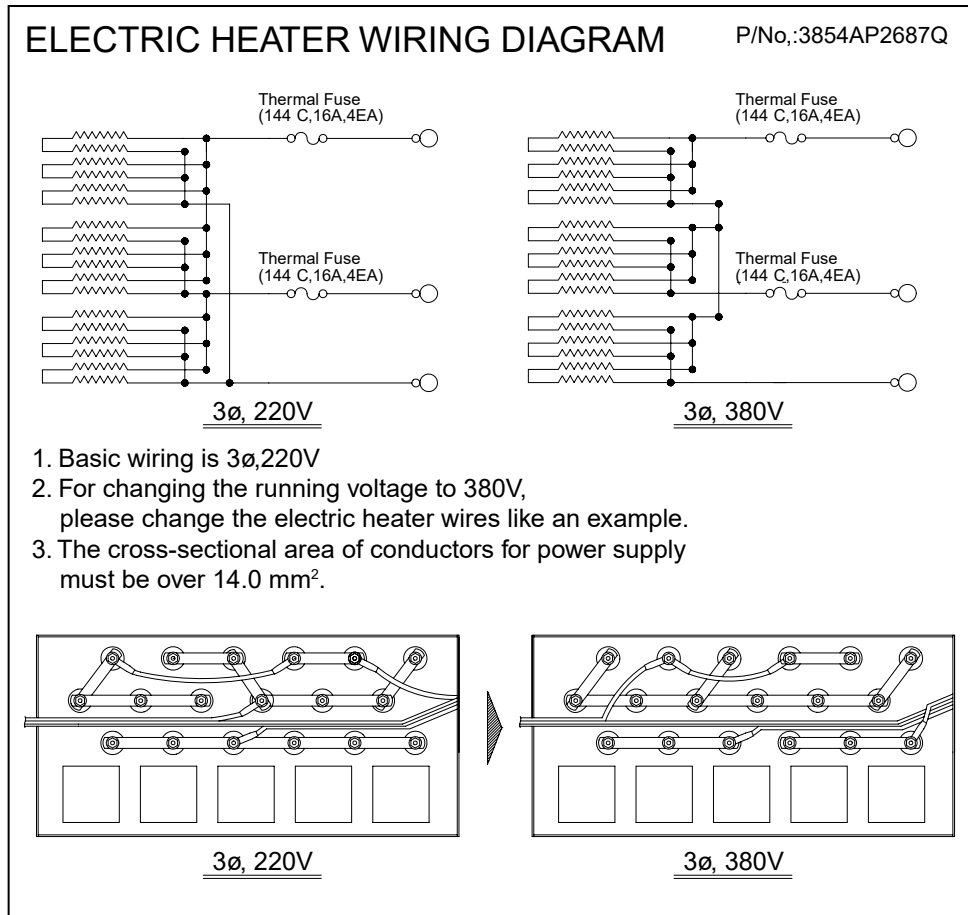

# 4.3 LP-15091CL

## • INDOOR UNIT

### WIRING DIAGRAM

P/NO: 3854A20026A

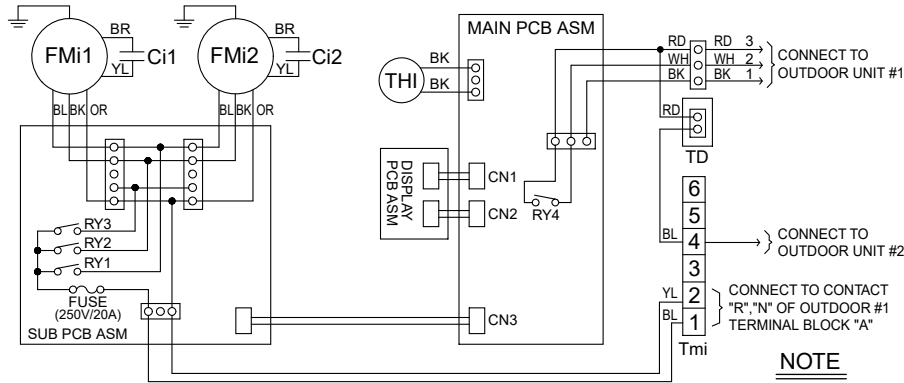

#### NOTE

BL : BLUE      WH : WHITE  
 BK : BLACK    YL : YELLOW  
 BR : BROWN    GN : GREEN  
 OR : ORANGE    GN/YL : GREEN/YELLOW  
 RD : RED

TD	5 SECOND DELAY TIMER	FMI1,2	INDOOR FAN MOTOR	THi	THERMISTOR FOR INDOOR TEMP.
Ci1,2	CAPACITOR(INDOOR)	Tmi	TERMINAL BLOCK(INDOOR)	Ry4	RELAY FOR COMP.

## • OUTDOOR UNIT

### OUTDOOR ELECTRIC CIRCUIT

P/NO: 3854A20026B

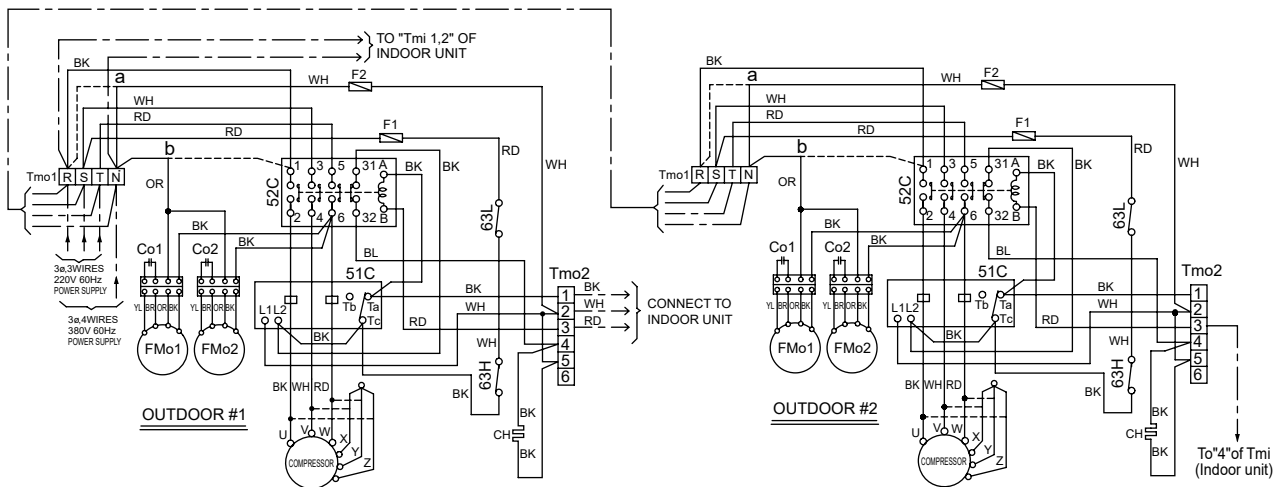

#### ( Caution )

- Basic wiring is 3φ,4wires,380V.
- For changing the running voltage to 220V, please change the wiring by the next steps  
 1st) Remove the "a" wires from the "N" of Tmo1(Outdoor unit #1,2), and connect the wire to the "R" of Tmo1(Outdoor unit #1,2)  
 2nd) Remove the "b" wire from Tmo1(Outdoor unit #1,2), and connect the wire to the "1" of 52C  
 3rd) Change the compressor wires like an example.

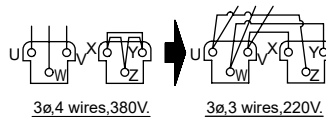

3φ,4 wires,380V.

3φ,3 wires,220V.

3. For setting the E.O.C.R current

Power supply	Current(A)	Time(sec.)
3φ,220V,60Hz	35	5
3φ,380V,60Hz	24.2	5

#### 4. Check list before test run

- 1st) Reconfirm the wiring of compressor and motor of indoor unit
- 2nd) Fasten the screw of "Tmo1" one more.

#### NOTE

BL : BLUE      RD : RED  
 BK : BLACK    WH : WHITE  
 BR : BROWN    YL : YELLOW  
 OR : ORANGE    GN : GREEN  
 GN/YL : GREEN/YELLOW

#### NOTE

CH	CRANKCASE HEATER
CO1,2	CAPACITOR FOR FAN
F1,2	FUSE
FMO1,2	OUTDOOR FAN MOTOR
51C	E.O.C.R FOR COMPRESSOR
Tmi	TERMINAL BLOCK(INDOOR)
Tmo1,2	TERMINAL BLOCK(OUTDOOR)
52C	MAGNETIC CONTACTOR FOR COMP.
63H	HIGH PRESSURE SWITCH
63L	LOW PRESSURE SWITCH

# 4.4 LP-15091XL

## • INDOOR UNIT

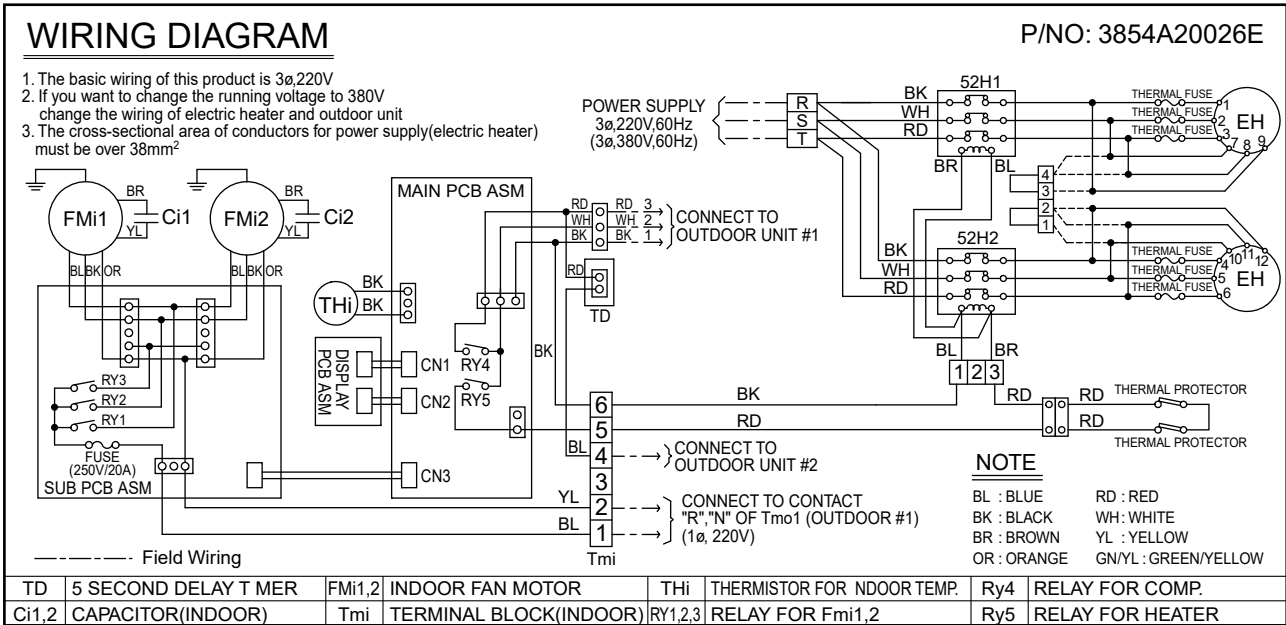

## • OUTDOOR UNIT

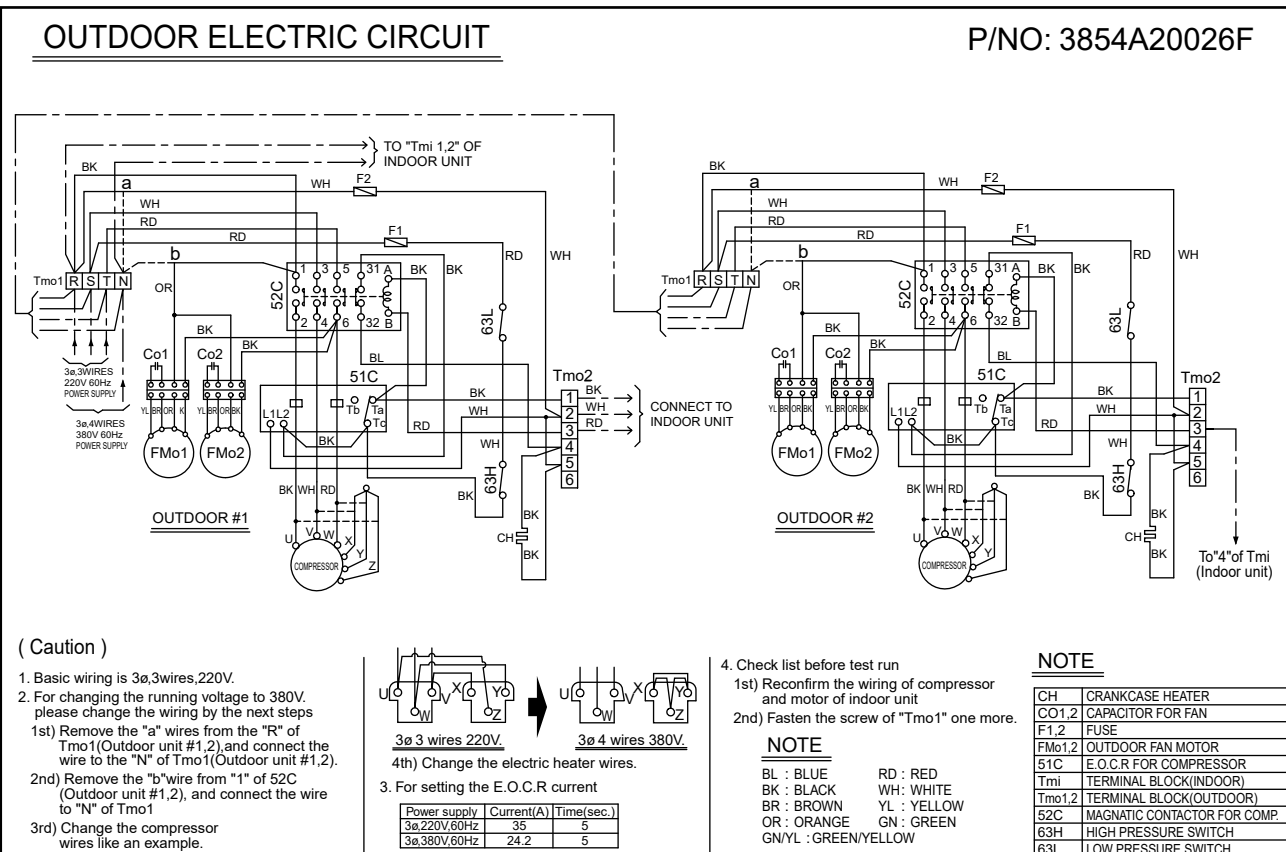

# 4.5 LP-20091CL

## • INDOOR UNIT

### INDOOR ELECTRIC CIRCUIT

( Caution )

1. Basic wiring is 3φ,4wires,380V.
2. For changing the running voltage to 220V, please change the wiring by the next steps

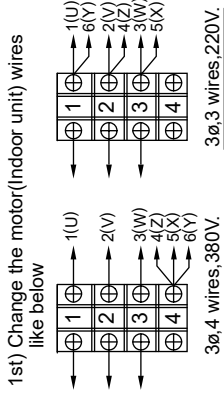

2nd) For setting the E.O.C.R current

Power supply	Current(A)	Time(sec.)
3φ,220V/60Hz	7	5
3φ,380V/60Hz	5	5

NOTE

CS	MODE SELECT SWITCH
FMi	INDOOR FAN MOTOR
GL1	LOW COOL OPERATION LAMP
GL2	HIGH COOL OPERATION LAMP
TH	E.O.C.R FOR FMI
Tmi	TERMINAL BLOCK(INDOOR)
23H,L	THERMOSTAT
52Fi	MAGNATIC CONTACTOR FOR FMI
CN	CONNECTOR(9P)
TD	5 SEC. DELAY T EMR

NOTE

- RD : RED
- BL : BLUE
- BK : BLACK
- WH : WHITE
- GY : GRAY
- BR : BROWN
- VT : VIOLET
- GN : GREEN
- OR : ORANGE
- GN/YL : GREEN/YELLOW

--- FIELD WIRING

CONNECT TO OUTDOOR #1  
TERMINAL BLOCK 'Tmo2'

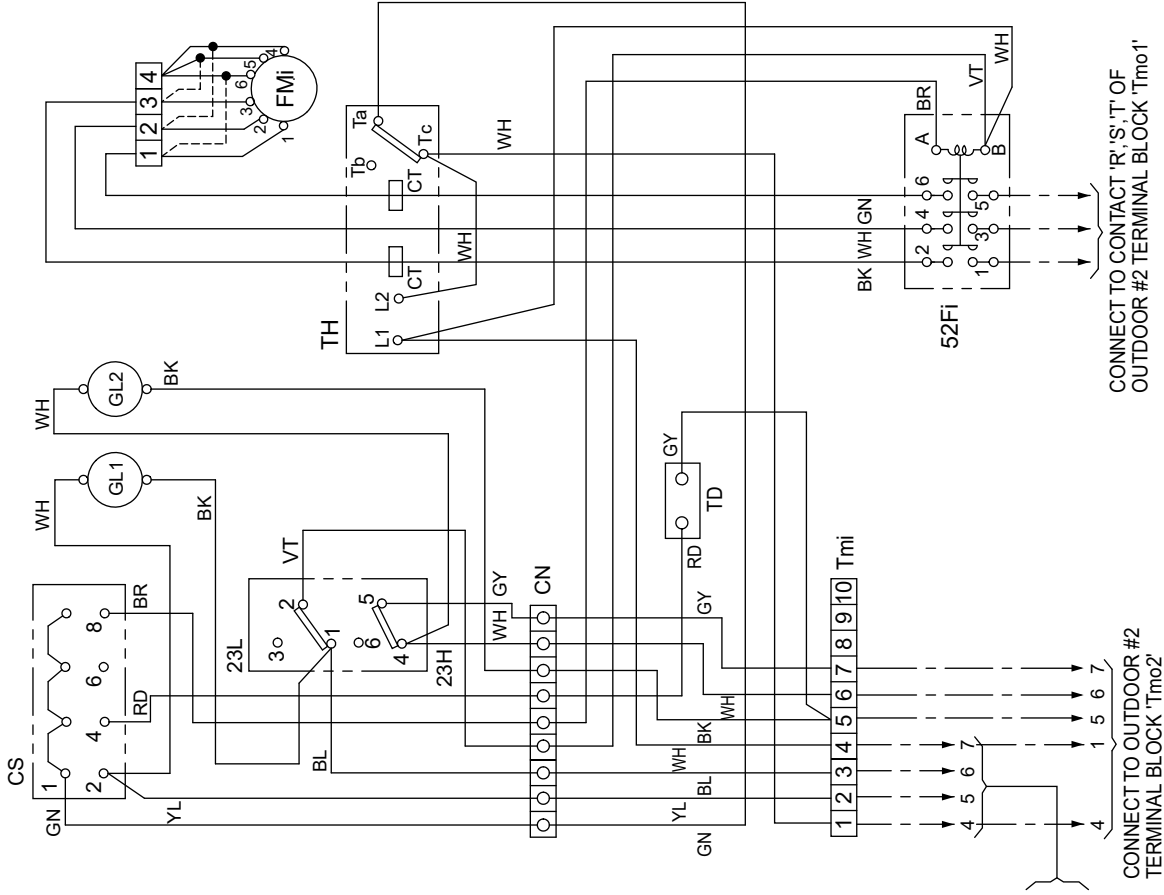

P/NO: 3854A20026C

• OUTDOOR UNIT

P/N: 3854A20026D

OUTDOOR ELECTRIC CIRCUIT

( Caution )

1. Basic wiring is 3ø, 4wires, 380V.
2. For changing the running voltage to 220V, please change the wiring by the next steps  
1st) Remove the "a" wires from the "N" of Tmo1(Outdoor unit #1), and connect the wire to the "R" of Tmo1(Outdoor unit #1).
- 2nd) Remove the "b" wire from Tmo1(Outdoor unit #1,2), and connect the wire to the "1" of 52C
- 3rd) Change the compressor wires like an example.

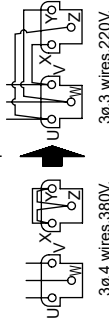

4th) Change the motor(Indoor Unit) wires like below

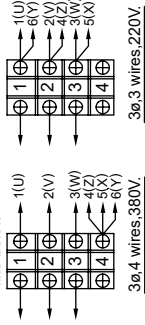

3. Remove F1,F2 of Outdoor unit #2.
4. For setting the E.O.C.R current  
1st) E.O.C.R for compressor

Power supply	Current(A)	Time(sec.)
3ø 220V/60Hz	55	5
3ø 380V/60Hz	40	5

2nd) E.O.C.R for motor(Indoor unit)

Power supply	Current(A)	Time(sec.)
3ø 220V/60Hz	7	5
3ø 380V/60Hz	5	5

5. Check list before test run  
1st) Reconfirm the wiring of compressor and motor of indoor unit  
2nd) Fasten the screw of "Tmo1" one more.

NOTE

CH	GRANICASE HEATER
CO1,2	CAPACITOR FOR FAN
CS	MODE SWITCH
F1,2	FUSE
FMI	INDOOR FAN MOTOR
FMO1,2	OUTDOOR FAN MOTOR
GL1	LOW COOL LAMP
GL2	HIGH COOL LAMP
TD	5 SEC. DELAY TIMER
TH	E.O.C.R FOR FMI
51C	E.O.C.R FOR COMPRESSOR
Terminal,2	TERMINAL BLOCK(OUTDOOR)
23H L	THERMOSTAT
52C	MAGNETIC CONTACTOR FOR COMP.
52F	MAGNETIC CONTACTOR FOR FMI
63H	HIGH PRESSURE SWITCH
63L	LOW PRESSURE SWITCH

NOTE

RD : RED  
 BR : BROWN  
 GN : GREEN  
 BK : BLACK  
 WH : WHITE  
 GN/YL : GREEN/YELLOW  
 F : FELD WIRING

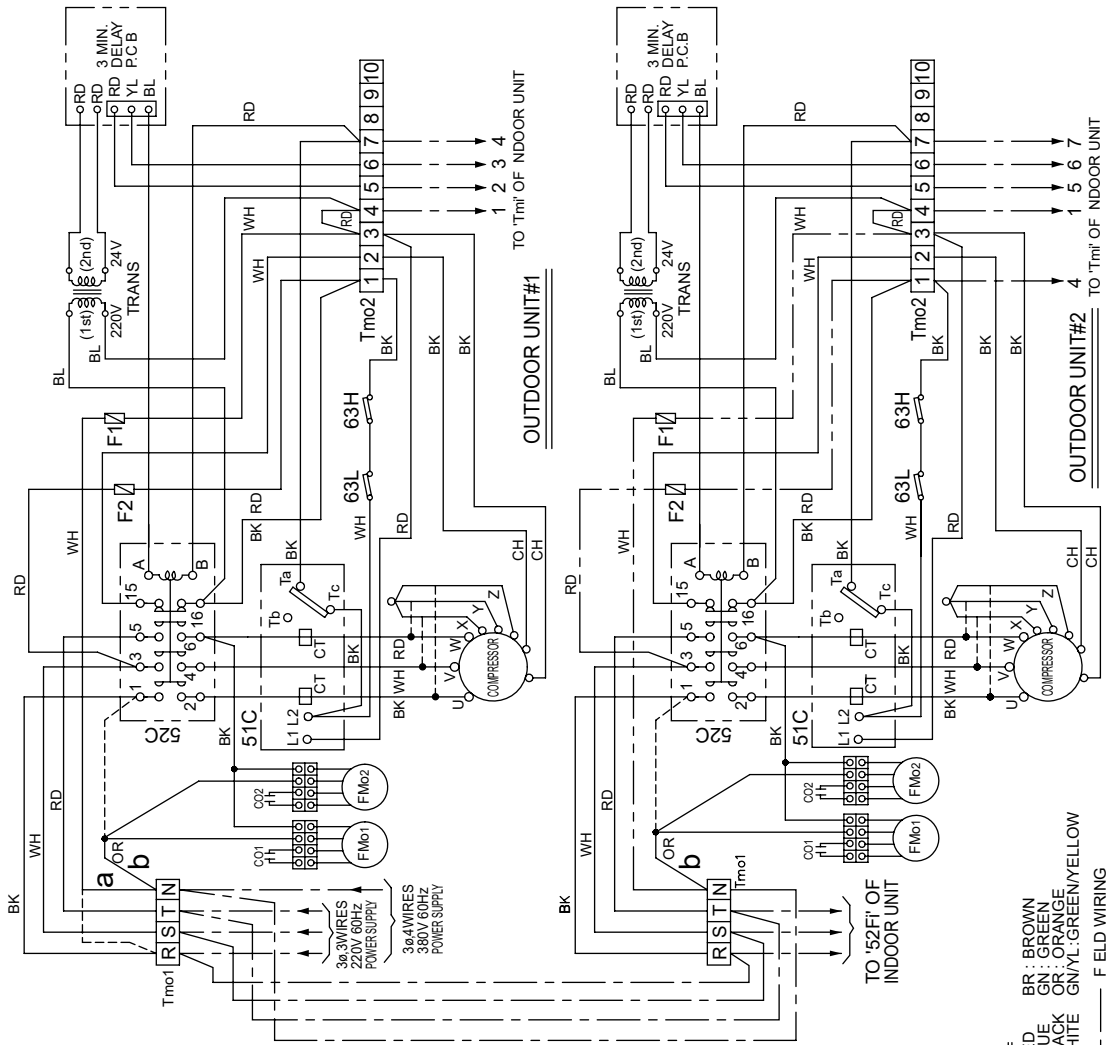

# 4.6 LP-20091XL

## • INDOOR UNIT

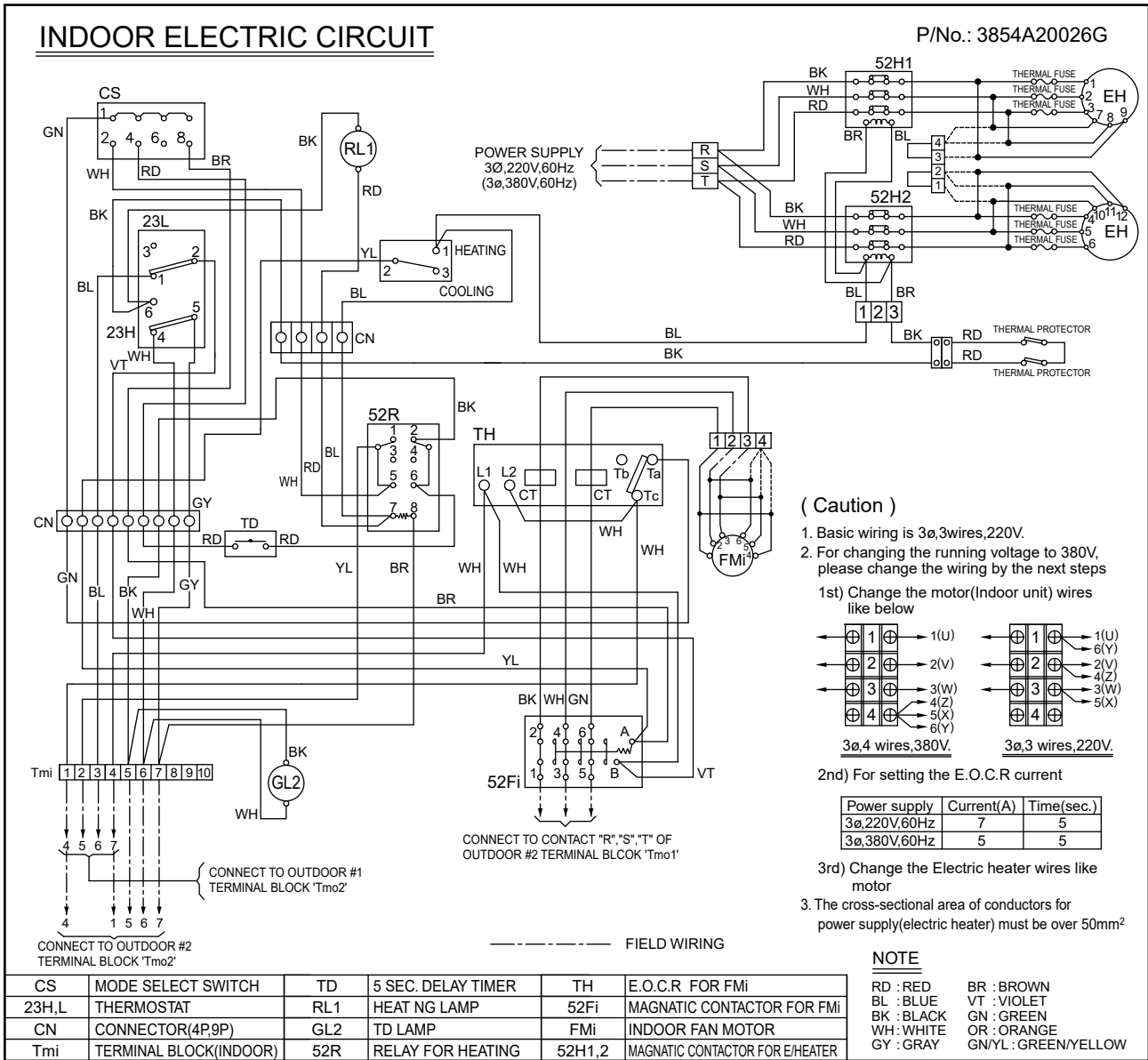

# • OUTDOOR UNIT

## OUTDOOR ELECTRIC CIRCUIT

P/NO: 3854A20026H

### ( Caution )

1. Basic wiring is 3ø,3wires,220V.
2. For changing the running voltage to 380V, please change the wiring by the next steps
  - 1st) Remove the "a" wires from the "R" of Tmo1(Outdoor unit #1), and connect the wire to the "N" of Tmo1(Outdoor unit #1).
  - 2nd) Remove the "b" wire from 52C(Outdoor unit #1,2), and connect the wire to the "N" of Tmo1(Outdoor unit #1).
  - 3rd) Change the compressor wires like an example.

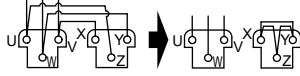

3ø,3 wires,220V.      3ø,4 wires,380V.

- 4th) Change the motor(Indoor Unit) wires like below

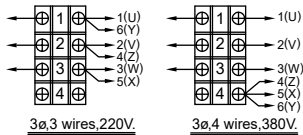

3ø,3 wires,220V.      3ø,4 wires,380V.

- 5th) Change the electric heater wires.

3. Remove F1,F2 of Outdoor unit #2.

4. For setting the E.O.C.R current

- 1st) E.O.C.R for compressor

Power supply	Current(A)	Time(sec.)
3ø,220V,60Hz	55	5
3ø,380V,60Hz	40	5

- 2nd) E.O.C.R for motor(Indoor unit)

Power supply	Current(A)	Time(sec.)
3ø,220V,60Hz	7	5
3ø,380V,60Hz	5	5

5. Check list before test run

- 1st) Reconfirm the wiring of compressor and motor of indoor unit
- 2nd) Fasten the screw of "Tmo1" one more.

### NOTE

CH	CRANKCASE HEATER
CO1,2	CAPACITOR FOR FAN
CS	MODE SWITCH
F1,2	FUSE
FMi	INDOOR FAN MOTOR
FMo1,2	OUTDOOR FAN MOTOR
GL1	LOW COOL LAMP
GL2	HIGH COOL LAMP
TD	5 SEC. DELAY TIMER
TH	E.O.C.R FOR FMI
51C	E.O.C.R FOR COMPRESSOR
Tmo1,2	TERMINAL BLOCK(OUTDOOR)
23H.L	THERMOSTAT
52C	MAGNETIC CONTACTOR FOR COMP.
52Fi	MAGNETIC CONTACTOR FOR FMI
63L	LOW PRESSURE SWITCH

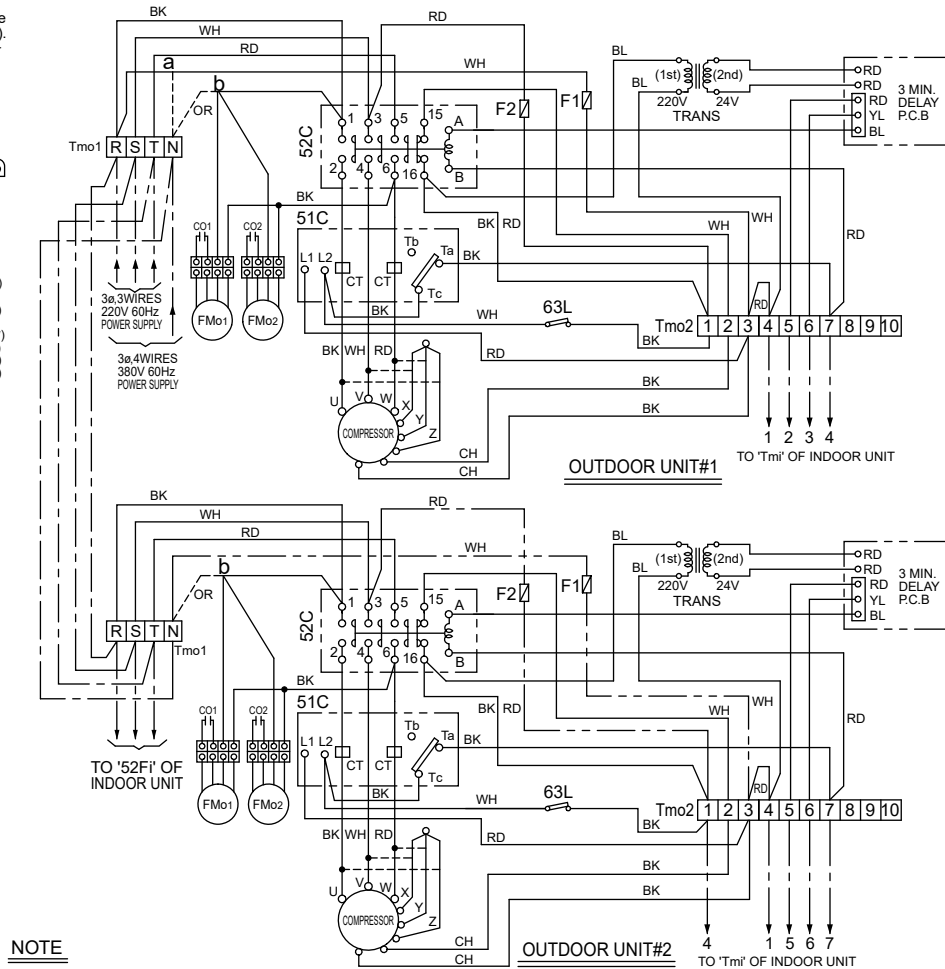

### NOTE

RD : RED	BR : BROWN
BL : BLUE	GN : GREEN
BK : BLACK	OR : ORANGE
WH : WHITE	GN/YL : GREEN/YELLOW
- - - - - FIELD WIRING	



# 5. OPERATION DETAILS

## (1) The function of main control

### 1. Time Delay Safety Control

- 3min... The compressor is ceased for 3 minutes to balance the pressure in the refrigeration cycle.  
(Protection of compressor)
- 3sec... The indoor fan is ceased for 3 seconds to prevent relay noise.  
(Protection of fan relay and micro chip)

### 2. Cooling Mode Operation

- When selecting the Cooling(❄) Mode Operation, the unit will operate according to the setting by the controller and the operation diagram is as following.

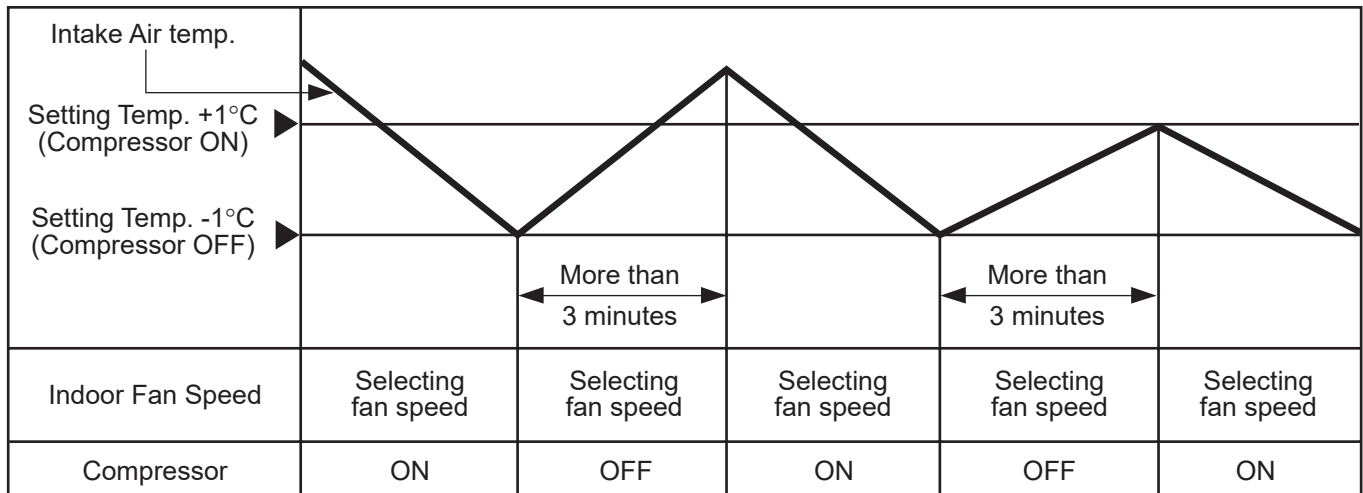

### 3. Soft Dry Operation Mode

- During Soft Dry Operation, the compressor ON temperature is the setting temperature plus 2°C, the compressor OFF temperature is the setting temperature minus 1°C.
- When the room temperature rises over the compressor ON temperature, the operation mode is switched to the Cooling mode.
- When the room temperature falls between the compressor ON temperature and OFF temperature, the operation mode is switched to the Soft Dry Operation.
- The operation diagram is shown below.

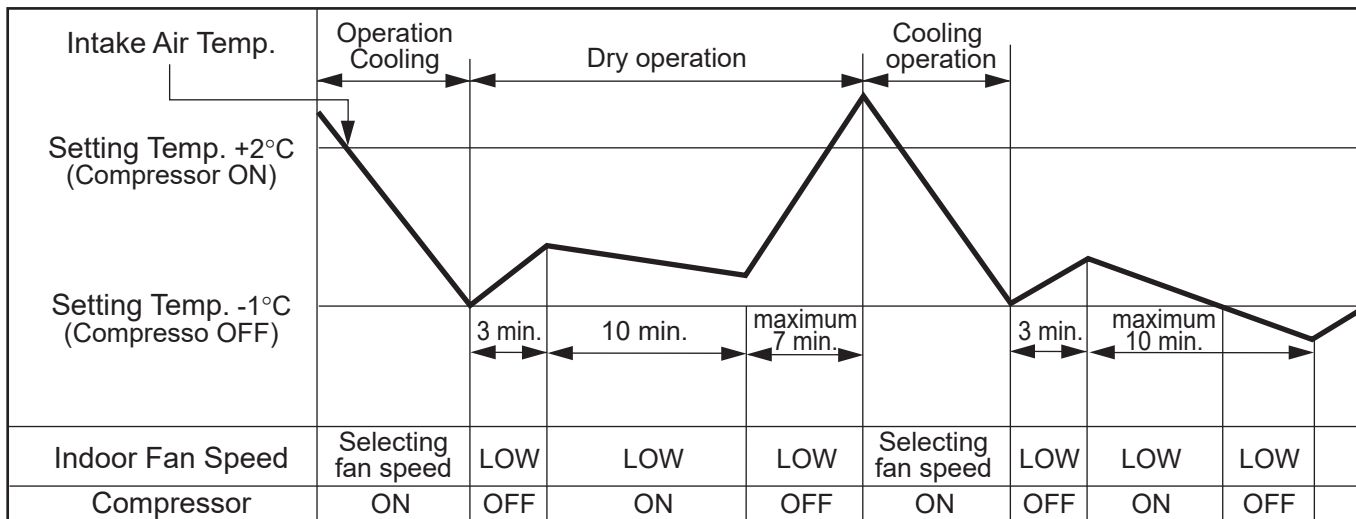

### 4. Protection of the evaporator pipe from frosting(LP-10091CL/XL)

- Compressor and outdoor fan stop when indoor pipe temperature is below -2°C and restart at the pipe temperature is above 12°C.

### 5. Off Timer Function (10K, 15K)

This function is to set the time of stopping the unit operation.

The procedure is as the following.

**1st:** Press the timer set button on the Remocon.

**2nd:** The buzzer sounds and then the display window shows the Off-Time to be set as 1:00 ... 7:00 0:00.

- The Off-Time is shifted as the following by each press.

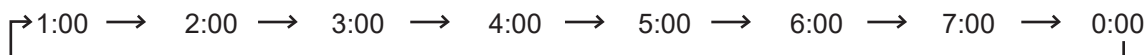

- If you select '0:00', the Off-Timer function will be cancelled.
- During Off-Timer Operation, if you repress the timer set button, the rest time will be displayed.

## 6. Alarm mode display / only displayed while operating. (10K, 15K)

**A10** : The sensor for sensing room temperature is open or short.

**A12** : Some keys of the display are out of order or short.

## 7. Function for Air-Circulation Air-Flow

- If you press Fan operation button, indoor Fan is only operating without compressor working.
- On Air-flow mode, temperature setting is not adjustable.
- Fan speed is adjustable by pressing Fan-speed button.

## 8. Function for Heater

- 1) On the set off mode, Heater and indoor fan operate without compressor working by pressing Heater ON/OFF button on the set.
- 2) Heater ON temperature is the setting temperature minus 1°C, Heater OFF temperature is the setting temperature plus 1°C.
- 3) On Heater ON, indoor fan is set to operate at Low-speed for 30 seconds and then operate at the setting speed.  
On heater OFF, indoor fan stops after operating at Low-speed for 30 seconds.(Except : LP-20091XL)
- 4) On Heater mode, changing mode is not adjustable
- 5) On heater ON, pressing Heater ON/OFF button or Start/Stop button stops the set after indoor fan operates at Low-speed for 30 seconds.(Except : LP-20091XL)

## 9. Child Lock function

The procedure is as the following

**1st**: Press the 2 buttons of the temperature control simultaneously, to raise-to lower on the Display Panel of the product for more 3 seconds.

**2nd**: The buzzer sounds and then the window of Display Panel shows **LOC** (LOC) mark.

**3rd**: To release this function, the reverse again the operating procedure could be done.

\* During this function is operating, any buttons of Display Panel don't work.

## 10. AUTO RESTART

In case the power comes on again after a power failure, Auto Restarting Operation is the function to operate procedures automatically to the previous operating conditions.

# 6. Installation

## 6.1 Installation of Indoor, Outdoor unit

### 1) Selection of the best location

#### Indoor unit

- There should not be any heat source or steam near the unit.
- There should not be any obstacles to prevent the air circulation.
- A place where air circulation in the room will be good.
- A place where drainage can be easily obtained.
- A place where noise prevention is taken into consideration.
- Do not install the unit near the door way.
- Ensure the spaces indicated by arrows from the wall, ceiling, fence, or other obstacles.

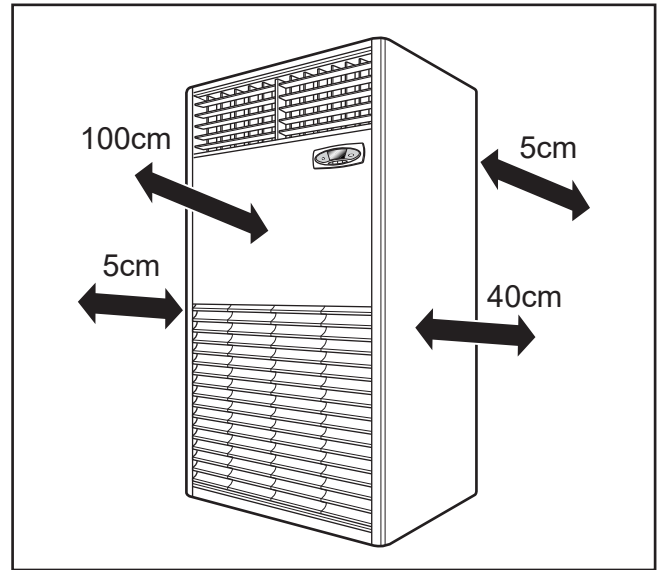

#### Outdoor unit

- If an awning is built over the unit to prevent direct sunlight or rain exposure, be careful that heat radiation from the condenser is not restricted.
- There should not be any animals or plants which could be affected by discharged hot air.
- Ensure the space indicated by arrows from the wall, ceiling, fence, or other obstacles.

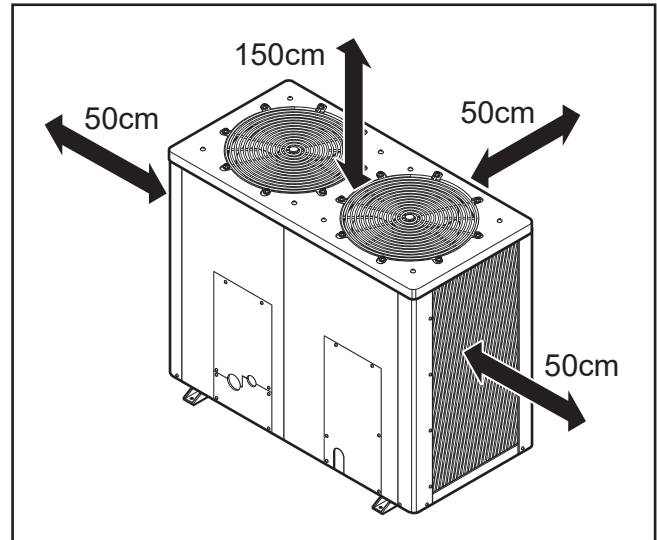

### Piping length and the elevation

MODEL	PIPE SIZE		Max. Length A (m)	Max. Elevation B (m)
	GAS SIDE	LIQUID SIDE		
~100K (BTU/h)	1 1/10"	1/2"	40	25
~150K (BTU/h)	1"	5/8"	40	25
~200K (BTU/h)	1 1/10"	5/8"	40	25

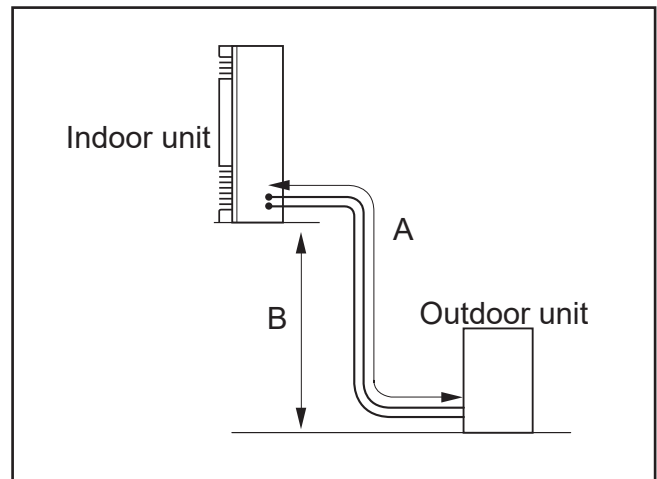

## 2) Indoor Unit installation

The mounting floor should be strong and solid enough to prevent it from vibration.

Drill the piping hole with 70mm diameter hole-core drill at either the right or the left of indoor unit. The hole should be slightly slant to the outdoor side.

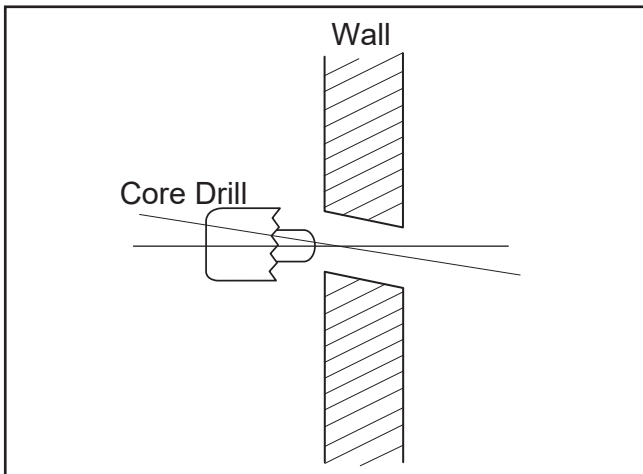
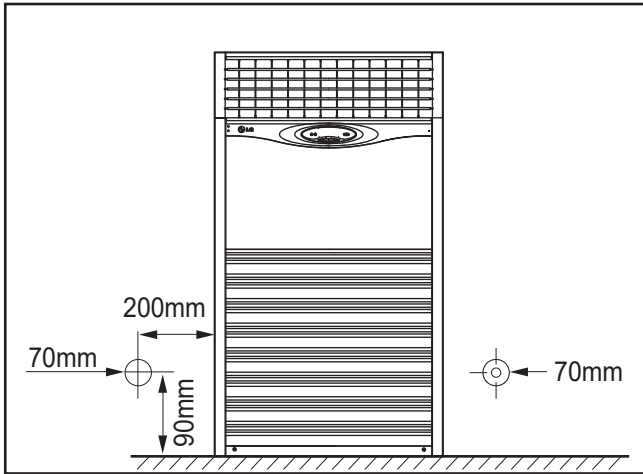

## 3) Outdoor unit Installation

Install the outdoor unit on the concrete or any solid base securely and horizontally.

If there is any vibration transmitted to the building, mount the rubber underneath the outdoor unit.

## 4) Refrigerant amount

Before shipment, this air conditioner is filled with the rated amount of refrigerant including additional amount required for air-purging, subject to 5m piping length. (The rated amount of refrigerant is indicated on the name plate.) But when the piping length exceeds 5 meters, additional charge is required according to the following table.

(Unit: g)

MODEL	REFRIGERANT CHARGE
~100K (BUT/h)	50 per 1m
~150K (BUT/h)	50 x 2 per 1m
~200K (BUT/h)	50 x 2 per 1m

Example) 72K~80K

In case of 10m long pipe(one-way), the amount of refrigerant to be replenished is:

$$(10 - 5) \times 50 = 250g$$

## 6.2 Installation Method

### 1) Procedure

No.	Installation works	Descriptions
1	Preparation of tools and installation parts	Preparation of installation
2	Flaring the pipes	To insert the flare nuts, mounted on the connection parts of both indoor and outdoor unit, onto the copper pipes.
3	Pipe bending	To reduce the flow resistance of refrigerant.
4	Connection of installation parts (elbows, socket etc)	Connection of long piping
5	Tighten the flare nut (outdoor)	Connecting the pipings of the outdoor unit.
6	Blowing the pipings	To remove dust and scale in working.
7	Tighten the flare nut (indoor)	Connecting the pipings of the indoor unit.
8	Check a gas-leakage of the connecting part of the pipings.	
9	Air purging of the piping and indoor unit	The air which contains moisture and which remains in the refrigeration cycle may cause a malfunction on the compressor
10	Open the 3-way (liquid side) and 3-way (gas side) valves.	
11	Form the pipings	To prevent heat loss and sweat
12	Checking the drainage (indoor unit)	To ensure if water flow drain hose of indoor unit.
13	Connecting the cable between outdoor and indoor unit	Preparation of the operating
14	Connecting the main cable to outdoor unit	
15	Supply the power to the crankcase heater (Before the operating the unit)	To prevent the liquid back to the compressor. (Heat pump only)
16	Cooling operation (Use the remote control or display of the indoor unit)	

## 2) Preparation of installation parts and tools

No.	Installation Parts, Tools	Use
1	Pipe cutter (MAX 35mm Copper pipe)	Cutting the pipings
2	Remear	Remove burrs from cut edges of pipes.
3	Wrench (H5, H4 hexagonal wrench)	To open the service valve
4	Pipe bender	Bending the pipings
5	Leak detector	Check a gas-leakage of connecting part of the pipings
6	Manifold gauge	To measure the pressure, to charge the refrigerant
7	Charge-nipple	To connect the bombe
8	Vacuum pump	To remove the air in the pipe.
9	Charge cylinder balance	To measure the refrigerant amount
10	Bombe (Freon-22)	Gas charge Air purge Cleaning the pipe
11	Spanner	To tighten the connecting parts of the pipings
12	Monkey spanner	
13	Driver( $\oplus, \ominus$ )	
14	Benchi (150mm)	Cutting the wires
15	Tapeline	To measure the length
16	Core drill	To make holes through the concrete wall and blocks
17	Voltmeter, Amperemeter, Clampmeter	To measure the current and voltage
18	Insulation resistance tester	To measure the insulation resistance
19	Glass thermometer	To measure the intake and ou let air temperature of he indoor unit
20	Copper tubes	To use the connecting pipings
21	Insulation material	To cover the connecting pipings
22	Tape	To finish the connecting pipings
23	Electrical Leakage Breaker	To shut off the main power
24	Cable	To connect the cable from outdoor unit to indoor unit
25	Drain hose sockets, elbows	To remote the condensing water

## 6.3 Piping of Indoor Unit

### 1) Preparation of piping

#### Cut the pipes and the cable

- Use the accessory piping kit or the pipes purchased locally.
- Measure the distance between the indoor and the outdoor unit.
- Cut the pipes a little longer than measured distance.
- Cut the cable 1.5m longer than the pipe length.

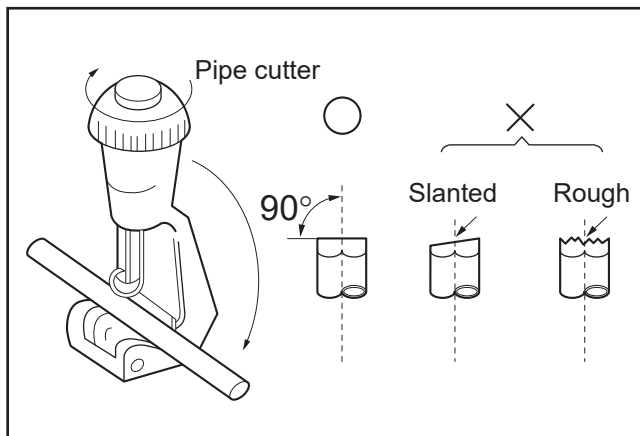

#### Remove burrs.

- Remove burrs from cut edges of pipes.
- Turn the pipe end down to avoid the metal powder entering the pipe.

#### Caution:

If burrs are not removed, they may cause a gas leakage.

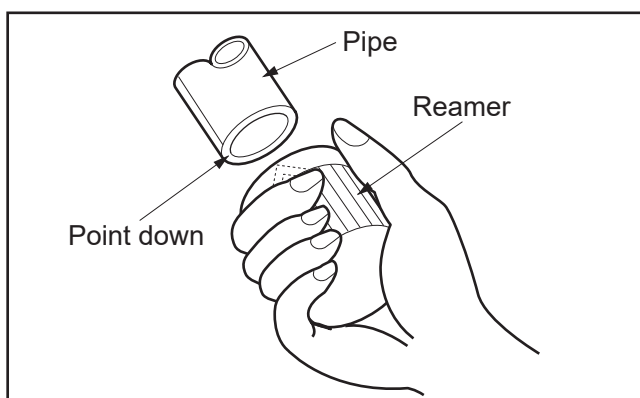

### 2) Connection of piping

#### Move the indoor tubing and drain hose to the hole

- Remove tubing holder and pull the tubing out of the chassis.

#### Replace the tubing holder into original position

#### Route the tubing and the drain hose straight backwards.

#### Insert the connecting cable into the indoor unit through the hole.

- Do not connect the cable to the indoor unit
- Make a small loop with the cable for easy connection later.

#### Tap the tubing and the connecting cable.

#### Indoor unit installation.

#### Connecting the pipings to the indoor unit.

- Align the center of the pipings and sufficiently tighten the flare nut with fingers.
- Finally, tighten the flare nut with torque wrench until the wrench clicks.  
When tightening the flare nut with torque wrench, ensure the direction for tightening follows the arrow on the wrench.



### 3) Precautions in bending

If it is necessary to bend or stretch the tubing, use the spring which is attached to the tubing in stead of pipe bender.

- Please make a careful notice to make a smooth line.
- Hold the tubing with your two hands closely and then bend or stretch it slowly not to make any crack.
- Remember that the radius (R) should not exceed 70mm (Refer to Fig. 1)

Do not repeat the bending process to prevent the tubing from cracking or crushing.

Keep in mind that the bending part should not be cracked and make the radius (R) as long as possible (Refer to Fig. 2)

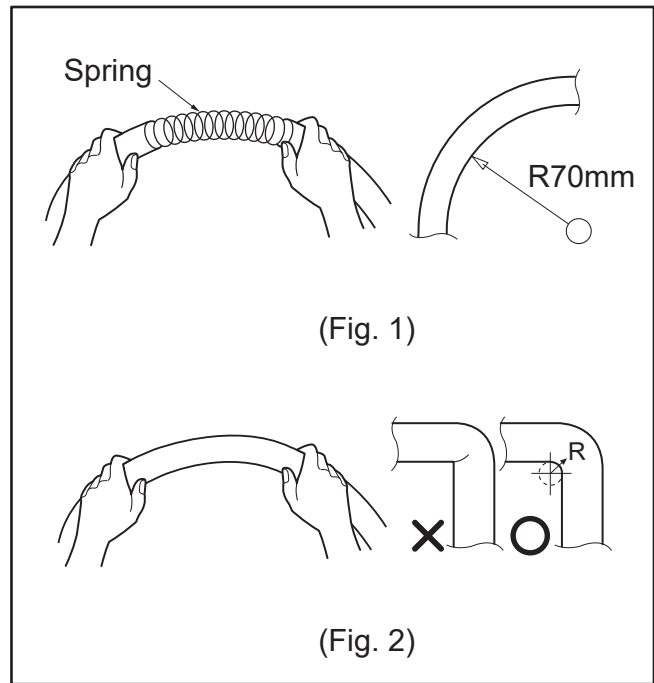

## 6.4 Connecting Piping to Outdoor Unit

### 1) Connecting pipings to the outdoor unit

Upon connecting 4-way valves, please weld connecting pipes using elbows instead of connecting pipes with flare nuts.

## 6.5 Connecting the Cable

Open the control board cover from the outdoor unit by removing the screws.

Connect wires to the terminals on the control board individually and secure the cables onto the control board with clamp.

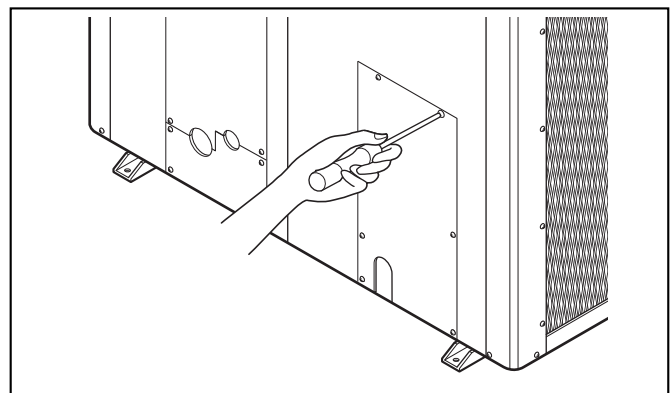

## 6.6 Power Supply and Wiring

The unit is completely wired internally at the factory according to general rule of electrical technology, but local rules, if they are required, should be complied with.

### 1) Power Supply

Power source must fulfill the following conditions:

**The working voltage should be higher than 90% and lower than 110% of the rated voltage marked on the name plate.**

**The starting voltage should be higher than 85% of the rated voltage marked on the name plate.**

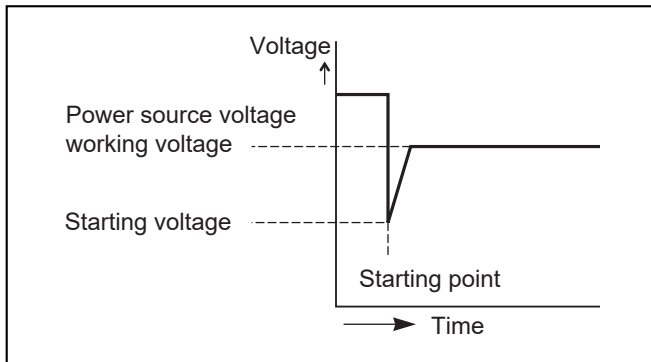

### 2) Wiring

After the confirmation of the above conditions, prepare the wiring as follows:

**Use the power supply cord(Rubber insulation, type Ho7RNF approved by HAR or SAA) suitable for the product's electrical capacity.**

MODEL	VOLTS	Conductor cross-sectional area	
		OUTDOOR	E/Heater
~100K (BUT/h)	450/ 750V	5.5mm <sup>2</sup>	14.0mm <sup>2</sup>
~150K (BUT/h)	450/ 750V	5.5mm <sup>2</sup>	38.0mm <sup>2</sup>
~200K (BUT/h)	450/ 750V	8.0mm <sup>2</sup>	50.0mm <sup>2</sup>

**Provide a recognized circuit breaker as below between power source and unit.**

**A disconnection device to adequately disconnect all supply lines must be fitted.**

**(for service operations)**

MODEL	Circuit breaker capacity	
	OUTDOOR	E/Heater
~100K (BUT/h)	50A	100A
~150K (BUT/h)	100A	100A
~200K (BUT/h)	100A	150A

**The screws which fasten the wiring in the casing of electrical fittings are liable to come loose from vibrations to which the unit is subjected during the course of transportation. Check them and make sure that they are all tightly fastened.**

**(If they are loose, it could give rise to burn-out of the wires.)**

**See to it that the starting voltage is maintained at more than 90 percent of the rated voltage marked on the name plate.**

**The following troubles would be caused by voltage drop-down.**

**Vibration of a magnetic switch, damage on the contact point there of, fuse breaking, disturbance to the normal function of a overload protection device.**

## 6.7 Wiring

### 1) LP-10091XL

#### • Wiring of Electric heater

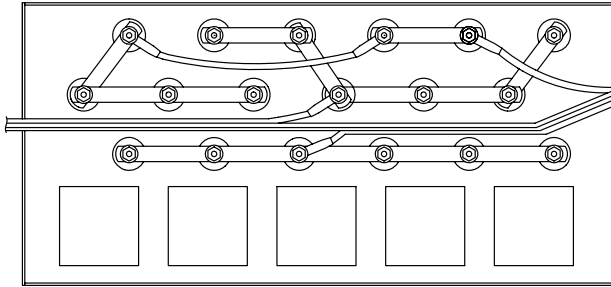

3Ø, 220V

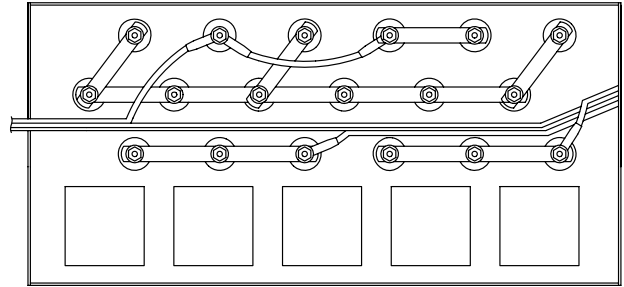

3Ø, 380V

### 2) LP-15091XL/20091XL

#### • Wiring of Control Box

POWER SUPPLY  
3Ø, 220V

TO CONTROL BOX

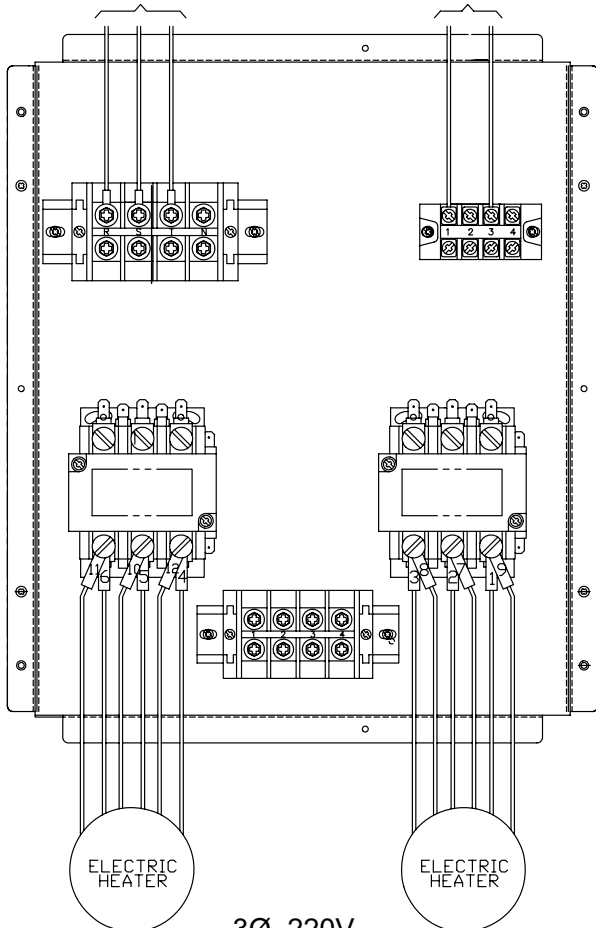

3Ø, 220V

POWER SUPPLY  
3Ø, 380V

TO CONTROL BOX

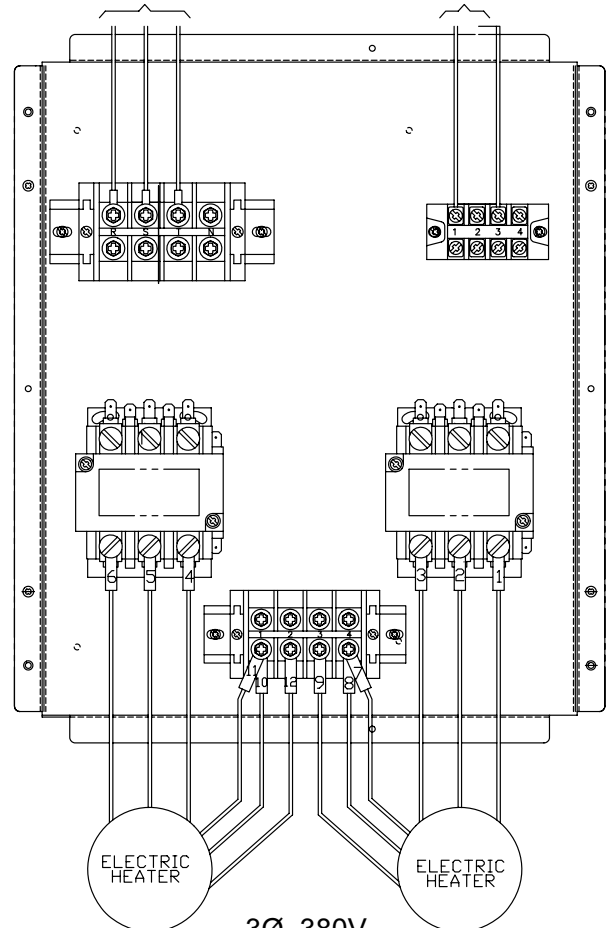

3Ø, 380V

## 6.8 Checking the Drainage and Form the Piping

### 1) Checking the Drainage

Remove the inlet grille.

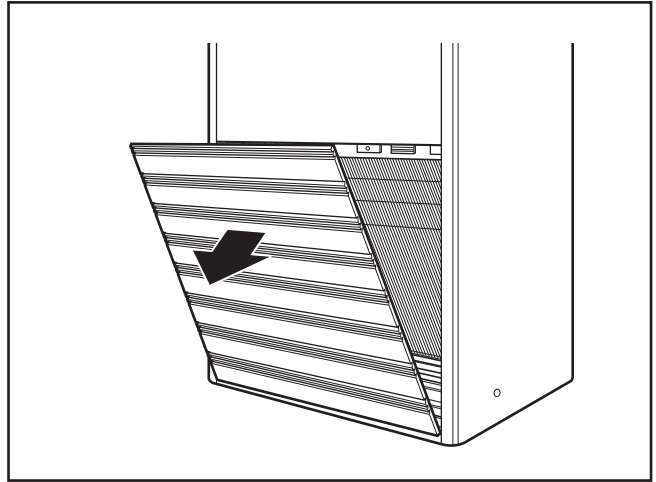

#### Check the drainage.

- Pour a glass of water into the drain pan.
- Ensure if water flows drain hose of indoor unit.

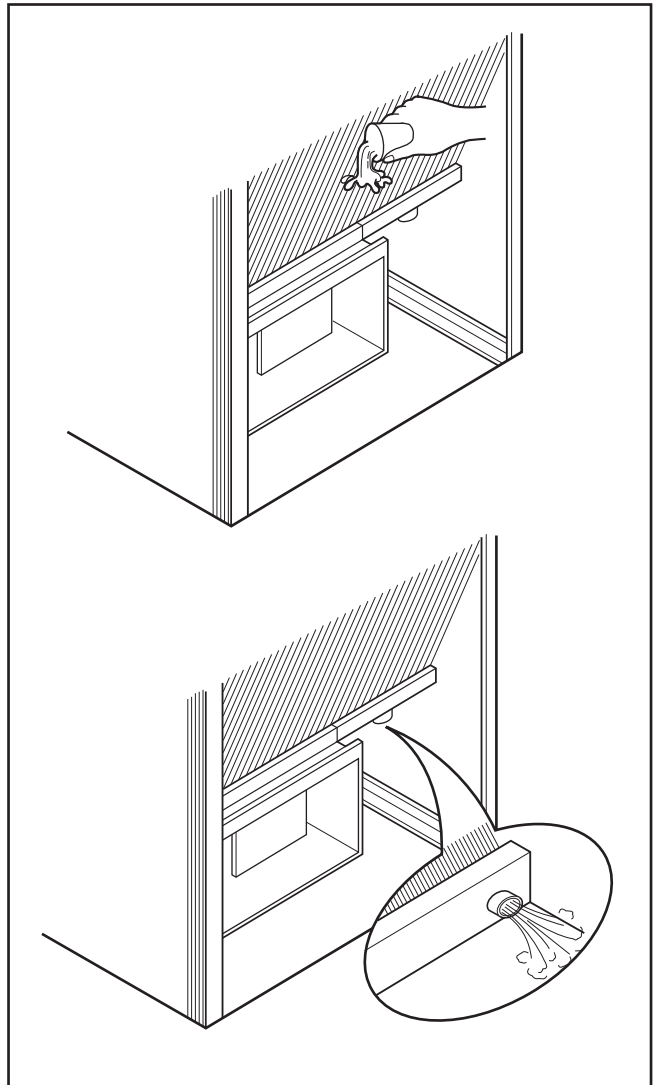

## 2) Form the Piping

Wrap the connecting portion of indoor unit with the insulation material and secure it with two Plastic Bands. (for the right piping)

- If you connect an additional drain hose, the end of the drain-outlet should be kept distance from the ground. (Do not dip it into water, and fix it on the wall to avoid swinging in the wind.)

In case of the outdoor unit is installed below position of the indoor unit.

Tape the Piping, and Connecting Cable from down to up.

Form the piping gathered by taping along the exterior wall and fix it onto the wall by saddle or equivalent.

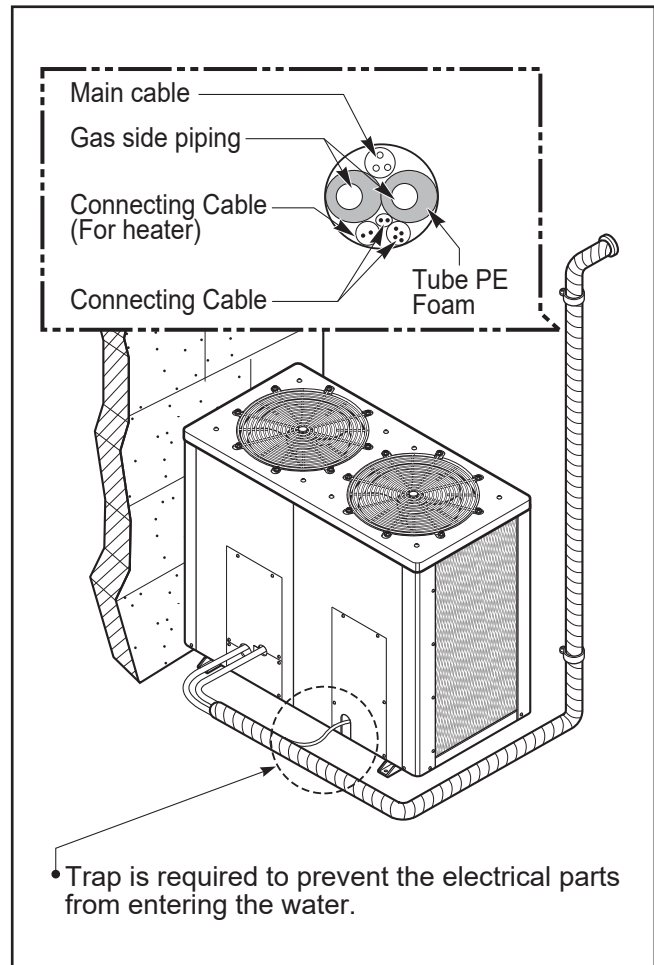

In case of the outdoor unit is installed upper position of the indoor unit.

Tape the piping and connecting cable from down to up.

In order to prevent water from entering the room, form a trap and tape the piping.

Fix the piping onto the wall with saddle or bracket.

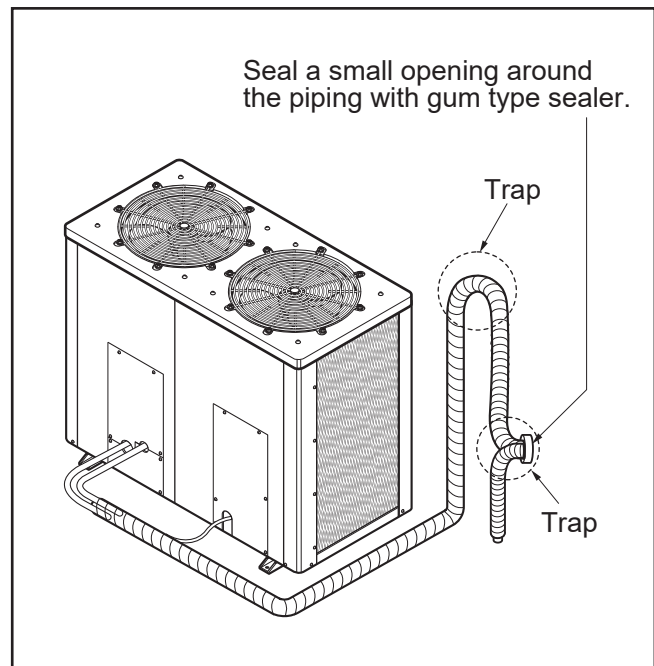

## 6.9 Final Check and Test Run

After installing the unit, perform the final check and running test as follows:

Final check points

**Is the unit securely mounted?**

**Is the installation location adequate?**

**Is the water piping work adequately and without leakage?**

**Are trapped drain lines installed at condensate drain connections?**

**Has the refrigeration cooling cycle been kept sealed?**

**Is the electrical wiring adequate and are the screws tightened on terminals?**

After the above final checkings, prepare the running test as follows:

**Connect compound gauges to the check joints at discharge and suction sides of the compressor.**

**Turn all switches "OFF".**

**Turn the main switch "ON".**

Running test should be accomplished as follows:

**Set operation switch at "FAN" and the fan will start. Check to ensure that the fan sounds normal.**

**Next, set it at "COOL" and the compressor will start. Check to ensure that the compressor sounds normal.**

**Check discharge and suction pressure on the compound gauges.**

**Check working voltage, phase balance and running current.**

**Check to ensure that the thermistor functions properly.**

**Check to ensure that the high pressure control switch functions correctly.**

## 6.10 Indoor Unit Controls and Indicators (LP-10091CL/XL, LP-15091CL/XL)

- Display

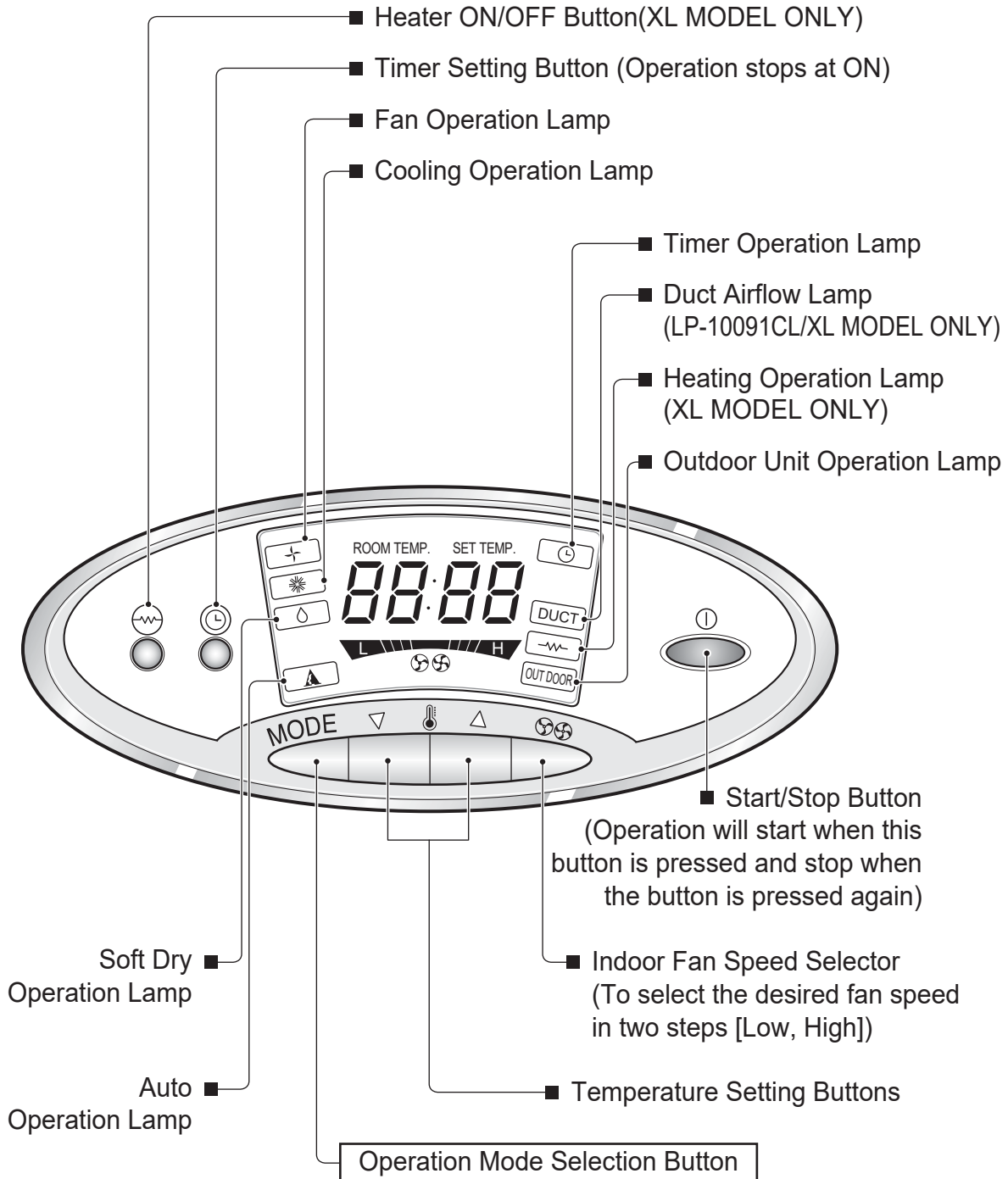

## 6.11 Indoor Unit Controls and Indicators(LP-20091CL/XL)

### • Controls

#### Cooling model

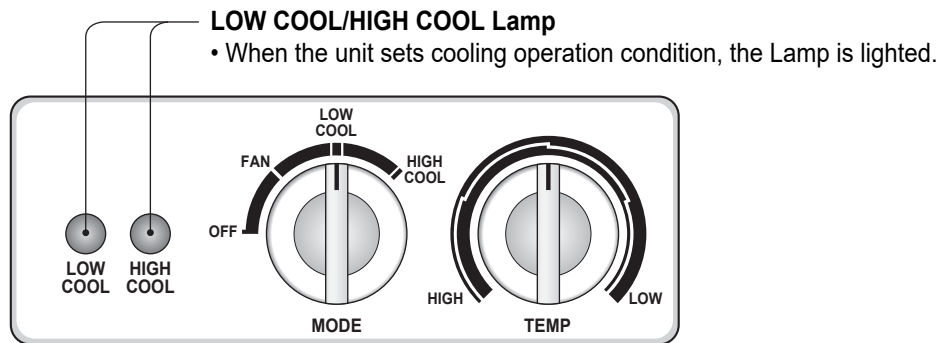

#### Heating and Cooling model

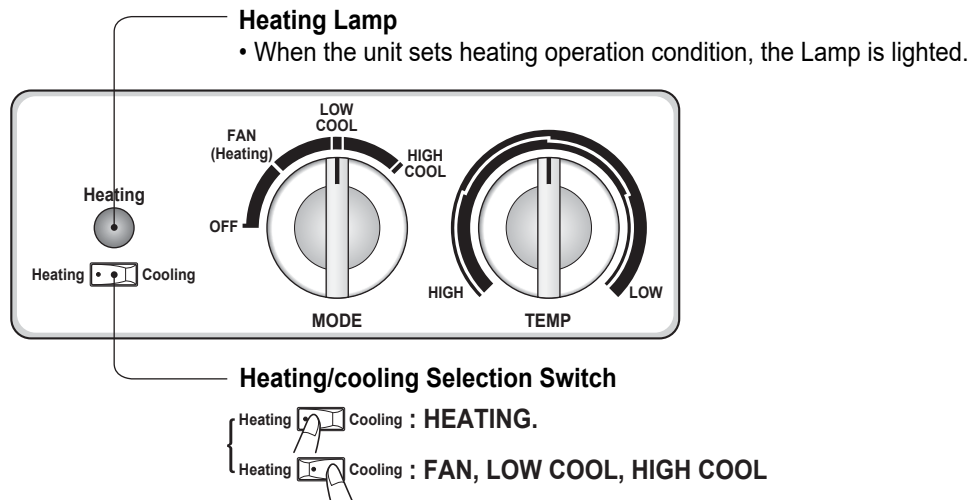

#### Mode

- OFF** : Turns the air conditioner off.
- FAN** : Permits the fan operation without cooling(heating).
- Heating** : Permits heating.
- LOW COOL** : Low Cool operation
- HIGH COOL** : High Cool operation

#### Temp

Turn the temp. control to the desired setting. The control position is a normal setting for average conditions. You can change this setting, if necessary, in accordance with your temperature preference.

If the room is too warm, turn the temp. control clockwise. If the room is too cool, turn the temp. control counterclockwise.



# 7. 3-WAY VALVE

		3-Way Valve (Liquid Side)	3-Way Valve (Gas Side)	
Works		Shaft position	Shaft position	Service port
Shipping		Closed (with valve cap)	Closed (with valve cap)	Closed (with valve cap)
1.	Air purging (Installation)	Open (counter-clockwise)	Closed (clockwise)	Open (push-pin)
Operation		Open (with valve cap)	Open (with valve cap)	Closed
2.	Pumping down (transferring)	Open (clockwise)	Open (counter-clockwise)	Open (connected manifold gauge)
3.	Evacuation (Servicing)	Open	Open	Open (with charging cylinder)
4.	Gas charging (Servicing)	Open	Open	Open (with charging cylinder)
5.	Pressure check (Servicing)	Open	Open	Open (with charging cylinder)
6.	Gas releasing (Servicing)	Open	Open	Open (with charging cylinder)

## 7.1 Air purging

Required tools: hexagonal wrench, adjustable wrench, torque wrench, and gas leak detector.

The additional gas for air purging has been charged in the outdoor unit.

However, if the flare connections have not been done correctly and there gas leaks, a gas cylinder and the charge set will be needed.

The air in the indoor unit and in the piping must be purged. If air remains in the refrigeration pipes, it will affect the compressor, reduce cooling capacity, and can lead to a malfunction.

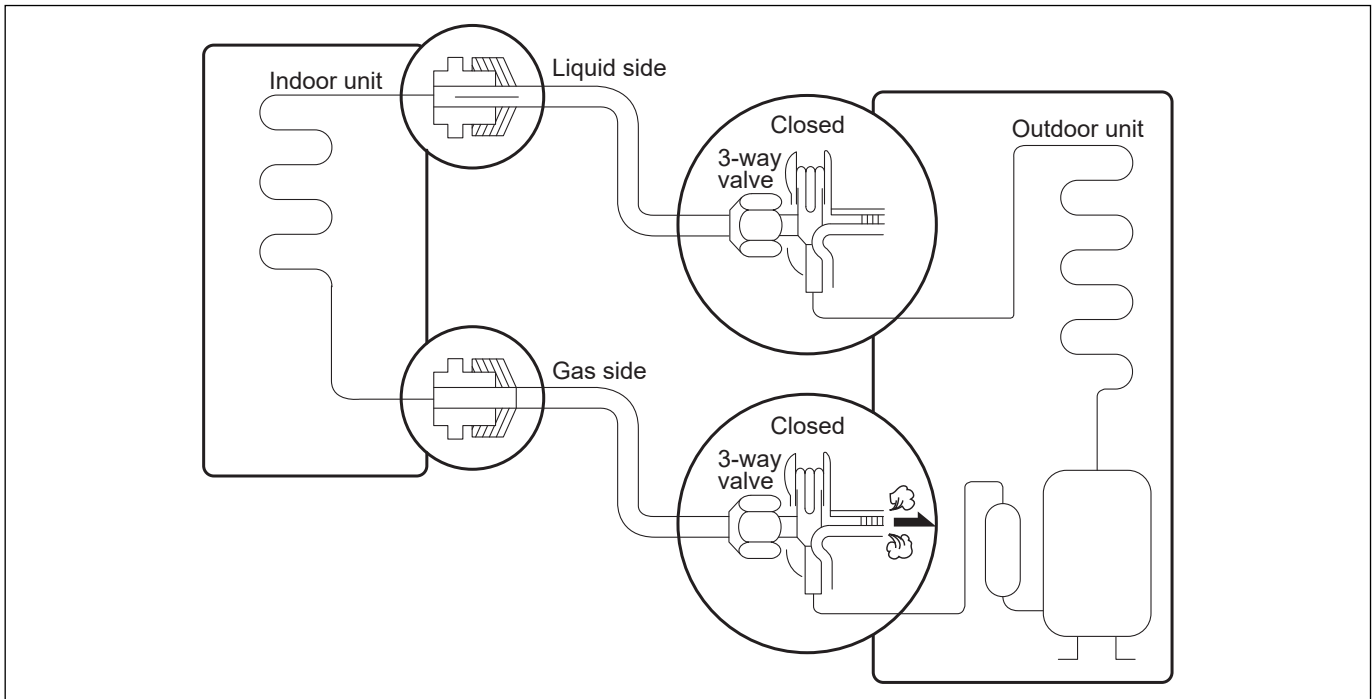

Service port nut.

Be sure, using a torque wrench to tighten the service port nut (after using the service port), so that it prevents the gas leakage from the refrigeration cycle.

### • Procedure

**Recheck the piping connections.**

**Open the valve stem of the 3-way(liquid side) valve counterclockwise approximately 90°, wait 10 seconds, and then set it to closed position.**

- Be sure to use a hexagonal wrench to operate the valve stem.

**Check for gas leakage.**

-Check the flare connections for gas leakage.

**Purge the air from the system.**

- Set the 3-way(liquid side) valve to the open position and remove the cap from the 3-way(gas side) valve's service port.

- Using the hexagonal wrench to press the valve core pin, discharge for three seconds and then wait for one minute. Repeat this three times.

**Use torque wrench to tighten the service port nut.**

**Set the 3-way (gas side) valve to the back seat.**

**Mount the valve stem nuts to the 3-way (liquid side) valve and 3-way (gas side) valves.**

**Check for gas leakage.**

• At this time, especially check for gas leakage from the 3-way (liquid side) valve and 3-way (gas side) valve's stem nuts, and from the service port nut.

### Caution

**If gas leakage is discovered in step above, take the following measures:**

If the gas leaks stop when the piping connections are tightened further, continue working from step .

If the gas leaks do not stop when the connections are retightened, repair the location of the leak, discharge all of the gas through the service port, and then recharge with the specified amount of gas from a gas cylinder.

## 7.2 Pumping down

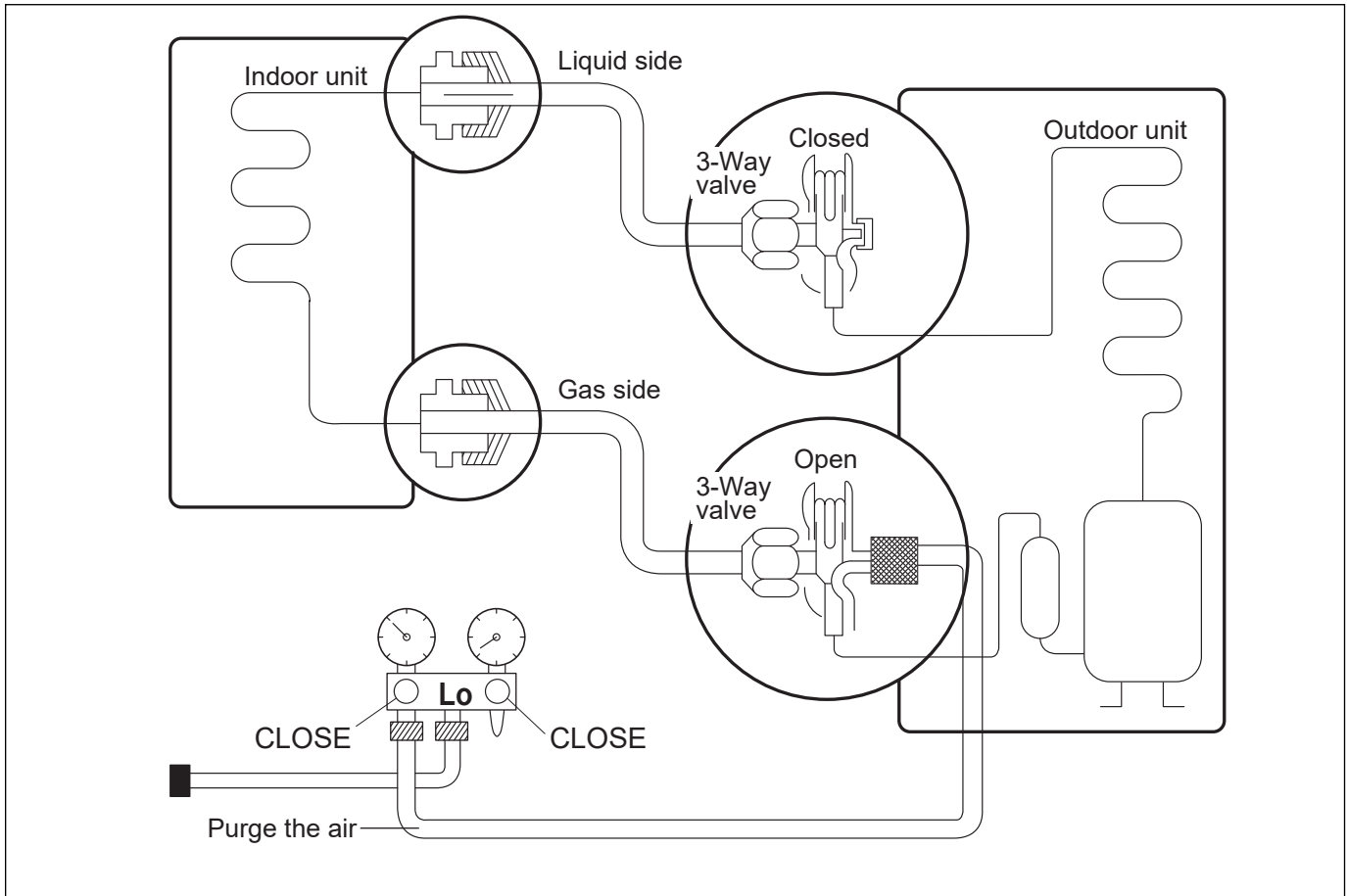

### • Procedure

**Confirm that both 3-way(liquid side) and 3-way(gas side) valves are set to the open position.**

- Remove the valve stem caps and confirm that the valve stems are in the raised position.
- Be sure to use a hexagonal wrench to operate the valve stems.

**Operate the unit for 10 to 15 minutes.**

**Stop operation and wait for 3 minutes, then connect the charge set to the service port of the 3-way (gas side) valve.**

- Connect the charge hose with the push pin to the service port.

**Air purging of the charge hose.**

- Open the low-pressure valve on the charge equipment slightly to purge air from the charge hose.

**Set the 3-way(liquid side) valve to the closed position.**

**Operate the air conditioner at the cooling cycle and stop it when the gauge indicates 1 kg/cm<sup>2</sup>g**

**Immediately set the 3-way(gas side) valve to the closed position.**

- Do this quickly so that the gauge ends up indicating 3 to 5kg/cm<sup>2</sup>g.

**Disconnect the charge set, and mount the 3-way(liquid side) and 3-way(gas side) valve's stem nuts and the service port nut.**

- Use torque wrench to tighten the service port nut.
- Be sure to check gas leakage.

## 1) Re-air purging (Re-installation)

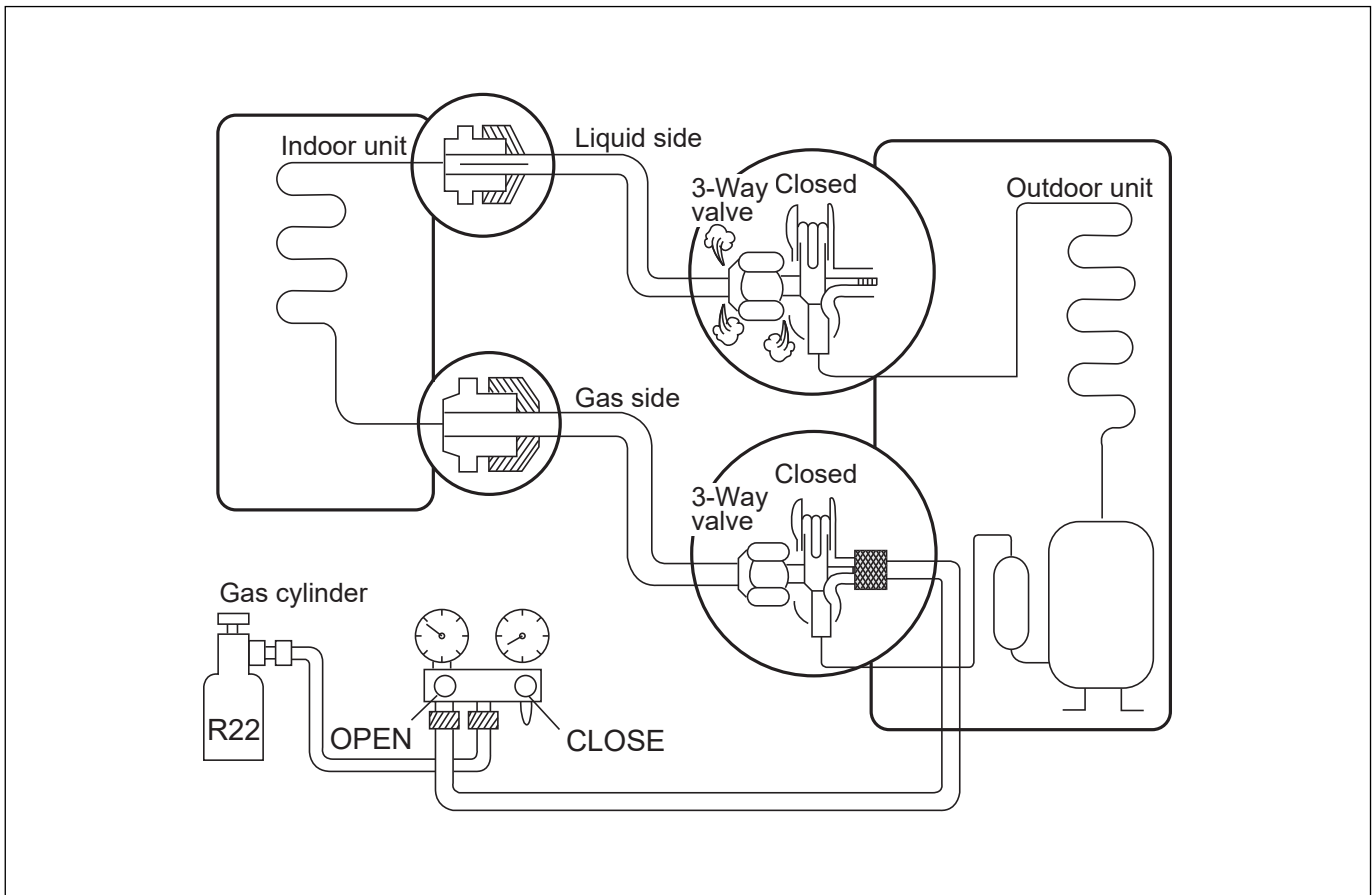

### • Procedure

**Confirm that both the 3-way (liquid side) valve and the 3-way(gas side) valve are set to the closed position.**

**Connect the charge set and a gas cylinder to the service port of the 3-way(gas side) valve.**

- Leave the valve on the gas cylinder closed.

### **Air purging.**

- Open the valves on the gas cylinder and the charge set. Purge the air by loosening the flare nut on the 3-way(liquid side) valve approximately 45° for 3 seconds then closing it for 1 minute; repeat 3 times.
- After purging the air, use a torque wrench to tighten the flare nut on liquid side valve.

### **Check gas leakage.**

- Check the flare connections for gas leakage.

### **Discharge the refrigerant.**

- Close the valve on the gas cylinder and discharge the refrigerant until the gauge indicates 3 to 5kg/cm<sup>2</sup>g

**Disconnect the charge set and the gas cylinder, and set the 3-way(liquid side) and 3-way(gas side) valves to the open position.**

- Be sure to use a hexagonal wrench to operate the valve stems.

### **Mount the valve stem nuts and the service port nut.**

- Use torque wrench to tighten the service port nut.
- Be sure to check gas leakage.

## 2) Balance refrigerant of the 3-way(liquid side), 3-way(gas side) valves (Gas leakage)

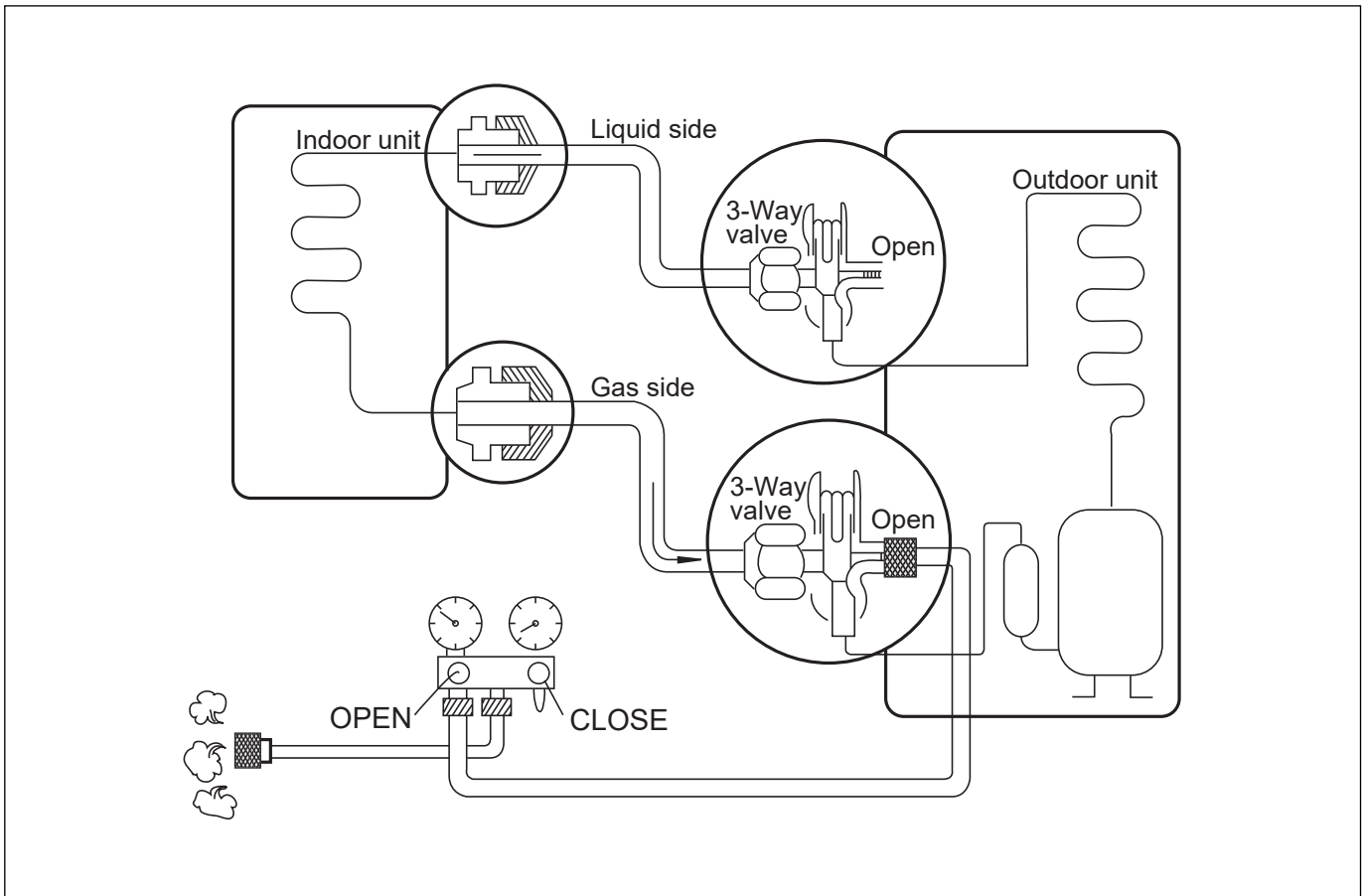

### • Procedure

Confirm that both the liquid side and gas side valves are set to the back seat.

Connect the charge set to the 3-way(gas side) valve's port.

- Leave the valve on the charge set closed.
- Connect the charge hose with the push pin to the service port.

Open the valve (Lo side) on the charge set and discharge the refrigerant until the gauge indicates 0 kg/cm<sup>2</sup>g.

- If there is no air in the refrigerant cycle (the pressure when the air conditioner is not running is higher than 1 kg/cm<sup>2</sup>g), discharge the refrigerant until the gauge indicates 0.5 to 1 kg/cm<sup>2</sup>g. In case of this, it will not be necessary to apply an evacuation.
- Discharge the refrigerant gradually; if it is discharged too suddenly, the refrigeration oil will also be discharged.

## 7.3 Evacuation

(All amount of refrigerant leaked)

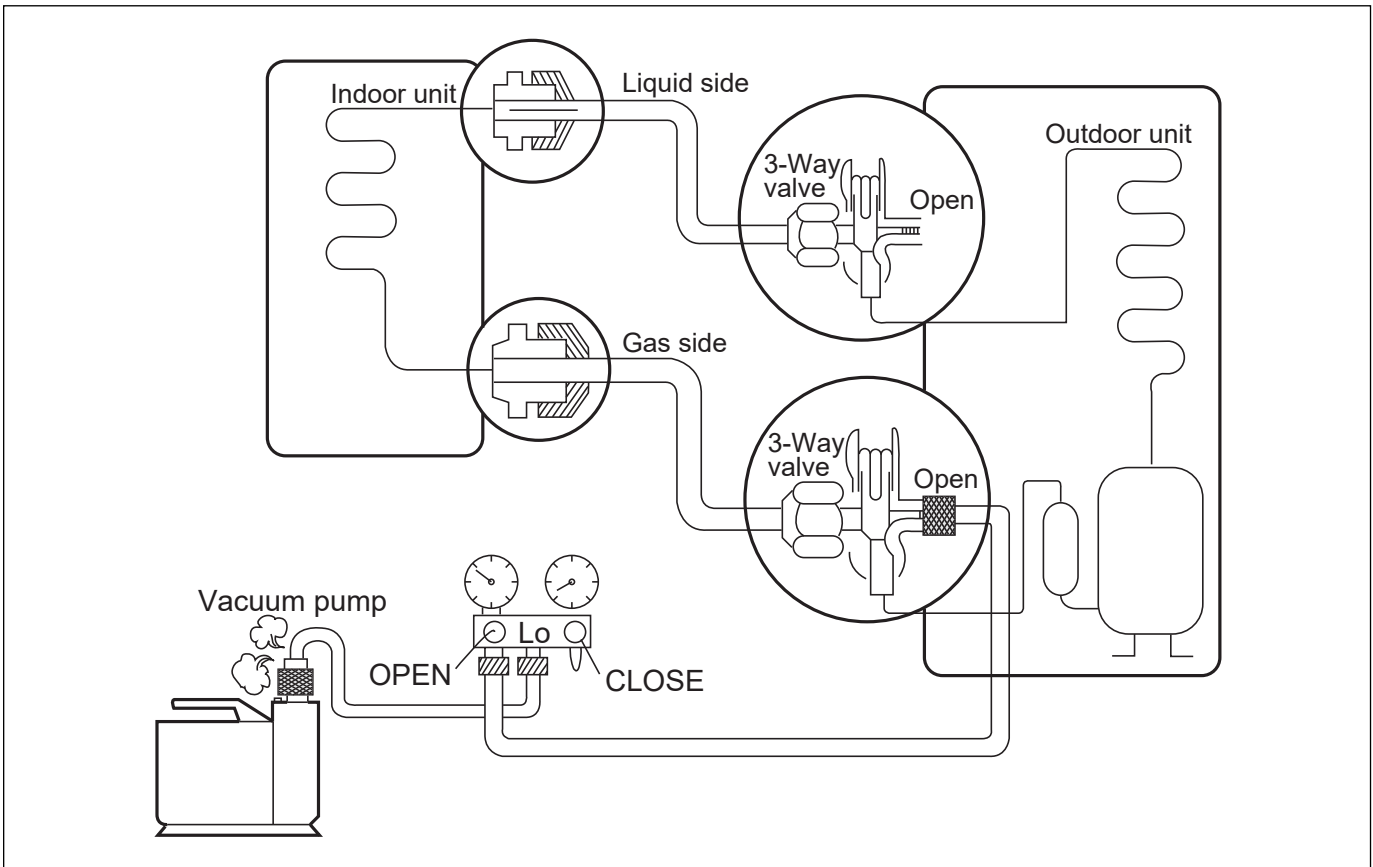

### • Procedure

**Connect the vacuum pump to the center hose of charge set.**

**Evacuation for approximately one hour.**

- Confirm that the gauge needle has moved toward -76cmHg (vacuum of 4 mmHg or less).

**Close the valve (Lo side) on the charge set, turn off the vacuum pump, and confirm that the gauge needle does not move (approximately 5 minutes after turning off the vacuum pump).**

**Disconnect the charge hose from the vacuum pump.**

- Vacuum pump oil.

If the vacuum pump oil gets dirty or depleted, replenish as needed.

## 7.4 Gas Charging

### 1) Cooling mode (After Evacuation)

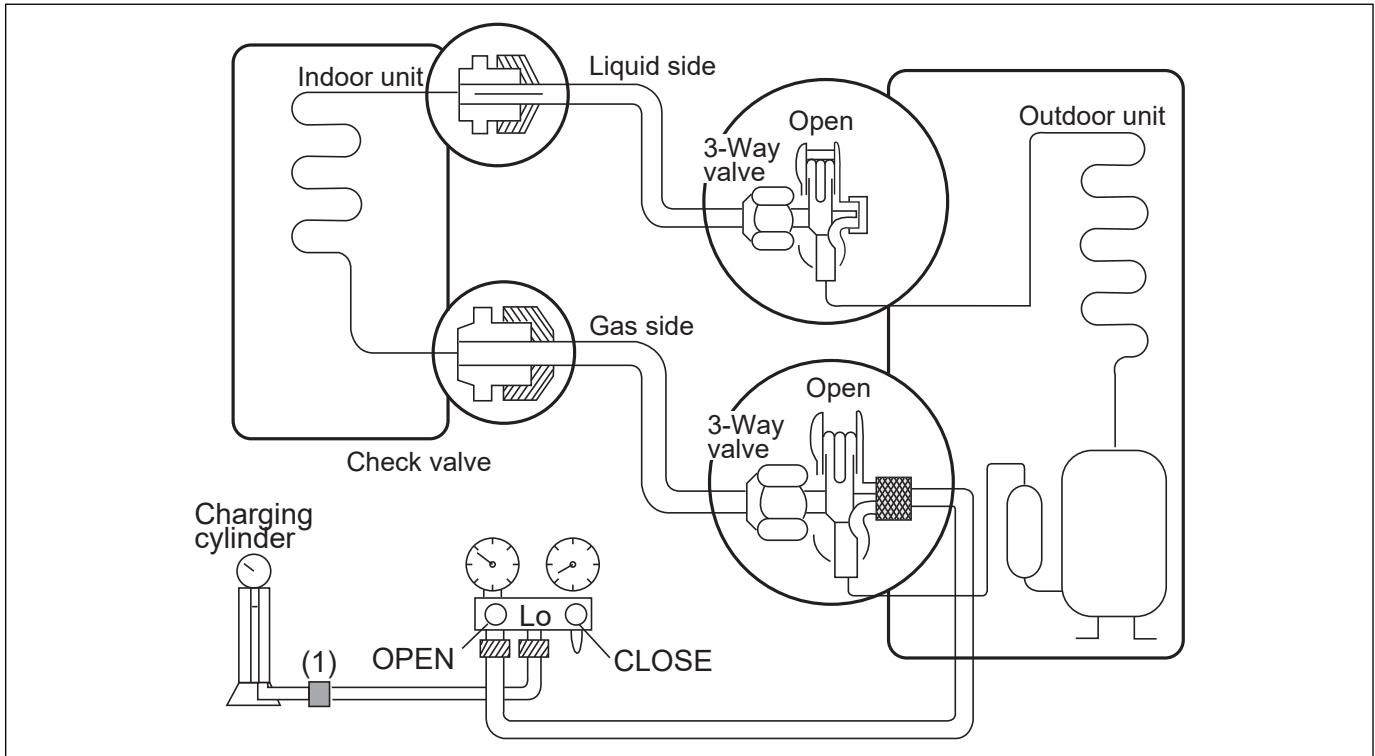

#### • Procedure

##### **Connect the charge hose to the charging cylinder.**

- Connect the charge hose which you disconnected from the vacuum pump to the valve at the bottom of the cylinder.
- If you are using a gas cylinder, use a scale and reverse the cylinder so that the system can be charged with liquid.

##### **Purge the air from the charge hose.**

- Open the valve at the bottom of the cylinder and press the check valve on the charge set to purge the air. (Be careful of the liquid refrigerant). The procedure is the same if using a gas cylinder.

##### **Open the valve (Lo side) on the charge set and charge the system with liquid refrigerant.**

- If the system can not be charged with the specified amount of refrigerant, it can be charged with a little at a time (approximately 150g each time) while operating the air conditioner in the cooling cycle; however, one time is not sufficient, wait approximately 1 minute and then repeat the procedure (pumping down-pin).

This is different from previous procedures.

Because you are charging with liquid refrigerant from the gas side, absolutely do not attempt to charge with larger amounts of liquid refrigerant while operating the air conditioner.

##### **Immediately disconnect the charge hose from the 3-way(gas side) valve's service port.**

- Stopping partway will allow the gas to be discharged.
- If the system has been charged with liquid refrigerant while operating the air conditioner turn off the air conditioner before disconnecting the hose.

##### **Mount the valve stem nuts and the service port nut.**

- Use a torque wrench to tighten the service port nut.
- Be sure to check gas leakage.

# 8. TROUBLESHOOTING GUIDE

In general, possible trouble is classified as two causes.

The one is so called **Starting Failure** which is caused from an electrical defect, and the other is **Ineffective Air Conditioning** caused by a defect in the refrigeration circuit and improper application.

## Unit runs but ineffective cooling

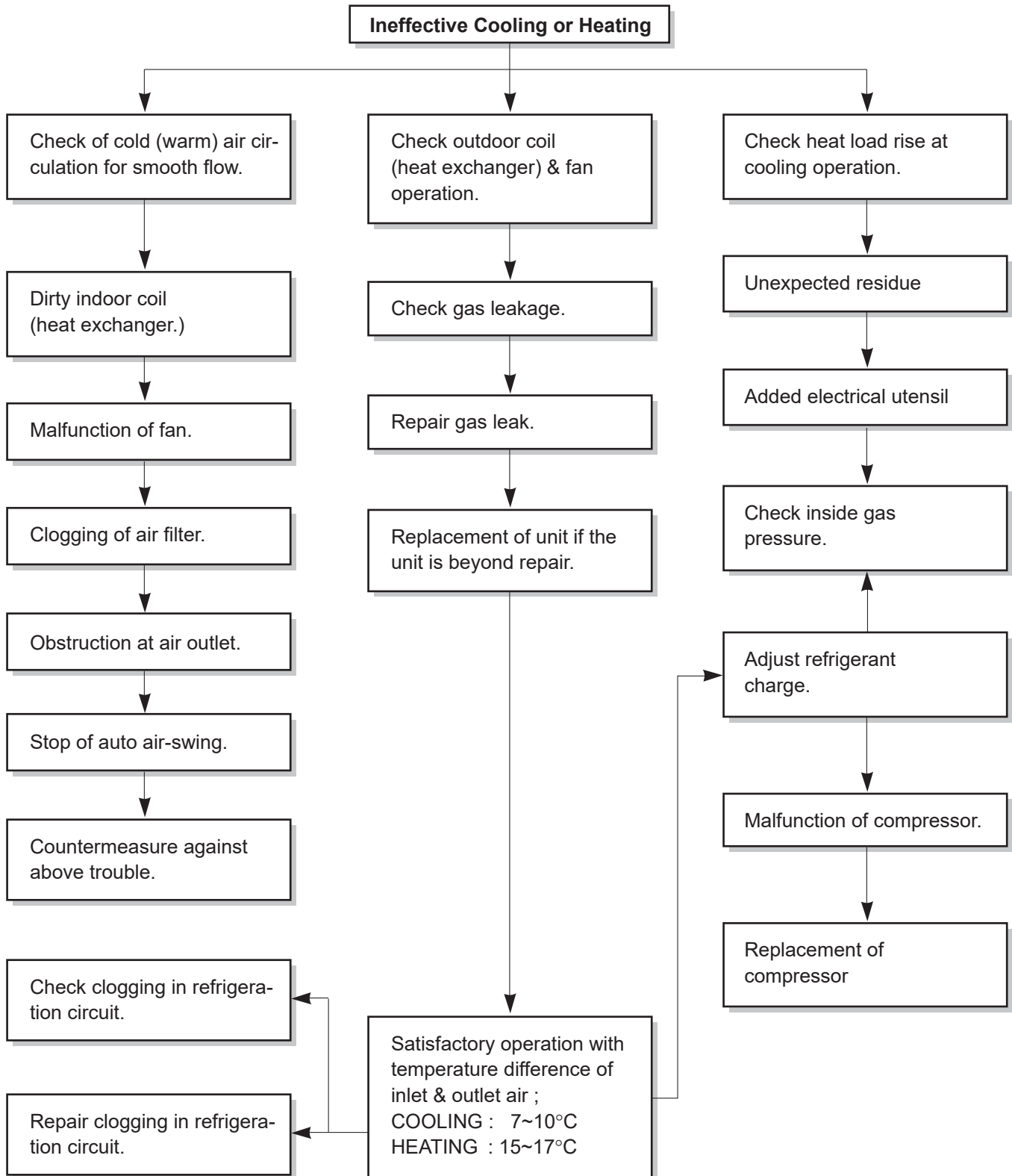



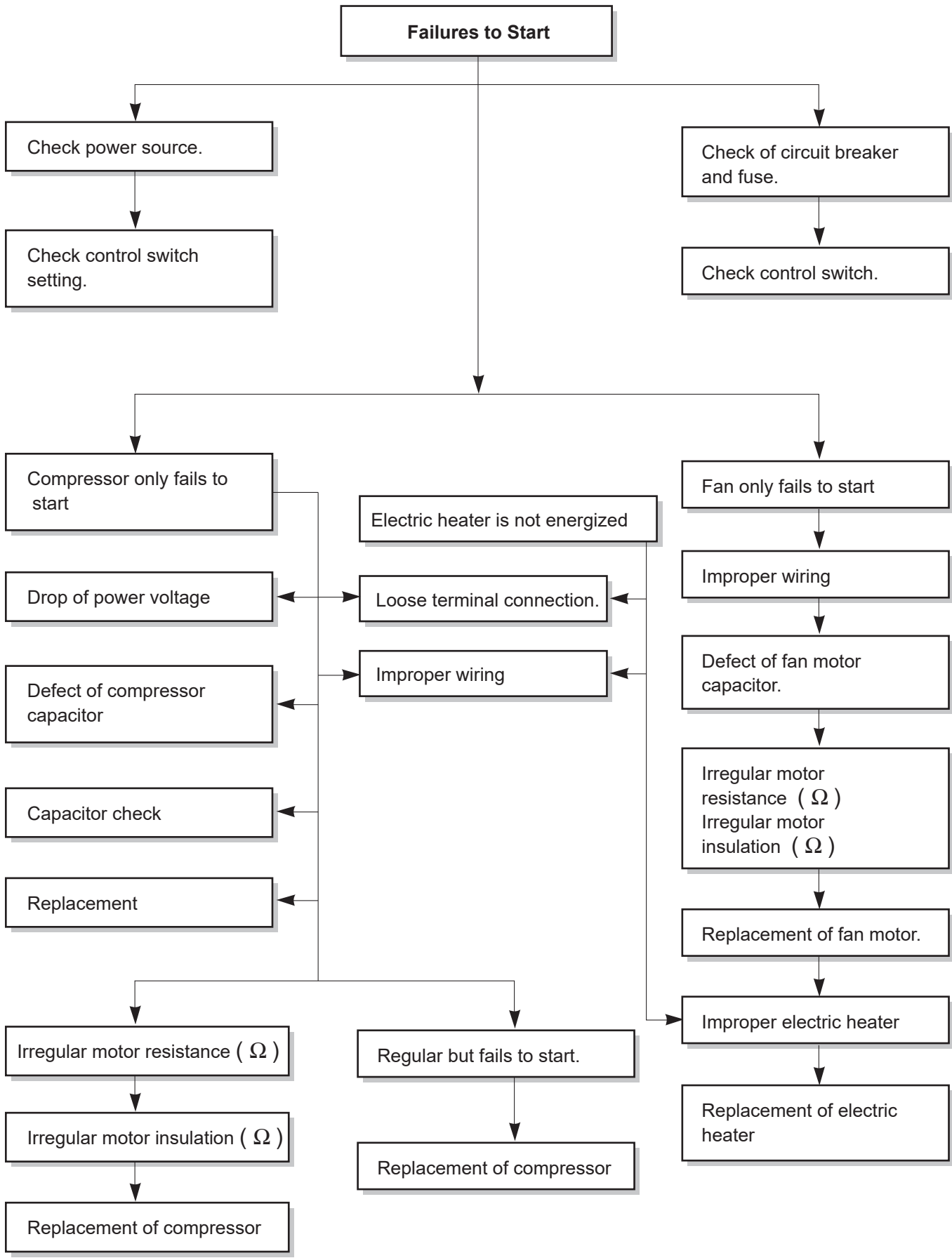

## PACKAGE AIR CONDITIONER VOLTAGE LIMITS

NAME PLATE RATING	MINIMUM	MAXIMUM
220 V	198 V	242 V
380 V	342 V	418 V

### 8.1 No cooling and heating operation performed

#### 1) Both the blower and the compressor do not work

WHAT TROUBLED	COMPLAINTS	HOW TO CHECK	REMEDY
Other parts than the unit	Electric supply interrupted Defective power wiring Cut of power fuse	Measure it with a tester in case that the same power source is supplied to other equipment than the unit, what and where trouble can be discovered by checking the operation of other equipment.	Repair a switch box and is relative instrument. Replacement of fuse Request a power supplier to repair.
	Too low voltage	Measure it with a tester.	Check the power source. Use a thick cable if necessary.
Magnetic switch for compressor & fan motor	Control point is on condition of "OFF" due to trouble.	Make short-circuit, then measure it with a tester.	Replace it if necessary.
Operating switch	Troubled or defective contactor	Check it with the eyes or tester.	Repair or replace it.
Protection devices	Opened the contact point with trouble	Check it with the eyes or tester.	Discover the trouble cause and push the rest button.

#### 2) Only blowers do not work

WHAT TROUBLED	COMPLAINTS	HOW TO CHECK	REMEDY
Air volume change over switch	Troubled or defective contact point	Check it with the eyes or a tester	Repair or replace it.
Capacitor	Defected	Check it with a tester.	Replace it.

### 3) Only outdoor fan does not work

WHAT TROUBLED	COMPLAINTS	HOW TO CHECK	REMEDY
Motor	Over-heated Layer short	Check how it is insulated.	Repair or replace it.
Electric Wiring	Open wire on operation	Check it with a tester.	Rewiring or repair.
	Short circuited on operation		

### 4) Only compressor does not work

WHAT TROUBLED	COMPLAINTS	HOW TO CHECK	REMEDY
Magnetic switch for compressor motor	Defective contact, magnetic coil troubled.	Check it with the eyes on with a tester.	Repair or replace it.
Compressor motor	Troubled over-heated (layer short)	Check how it is insulated.	Replace or repair the compressor.
Compressor	Troubled or over-heated (lock)	Groaned noise of motor	Repair or replace it.
High pressure switch	Troubled or defective contact or operating	Check it with a tester.	Replace it if necessary.
Electric circuit	Defective connection or disconnection of the circuit for compressor.	Check it with a tester.	Rewiring or push reset button.

## 8.2 The Units discontinue after the operation started

WHAT TROUBLED	COMPLAINTS	HOW TO CHECK	REMEDY
Other parts than the unit	Improper opening of the service valves in the refrigerant line	Checking	Open it properly
Outdoor coil	Coil is dirty *1	Checking	Wash it by means of something like chemical washing.
In-condensable gas blended.	Air intruded into the refrigerant pipe line *1	In the event that difference between the saturating temperature corresponding to high pressure and the temperature of air discharged from the outdoor coil is more than 15°C, incondensable gas may be blended.	Extract air by vacuum pump, then recharge the refrigerant.
High pressure switch	Improper adjustment	Check it with a pressure gauge.	Readjust it to normal operating pressure. (Note) Don't alternate the specified adjusting pressure. If the adjusted pressure exceeds the specified range, it will cause a great accident.
Refrigerant	A shortage of refrigerant amount. * 2		Recharge the refrigerant. Repair the spot where it leaks.
Outdoor Fan	Reverse rotation of fan Obstacle Air short circuit *1	Confirm the wind blowing out.  Check it with eyes.	If reversed, connect interchanged wires to each terminal. Power wirings.

**Note:** Use an appropriate measuring instrument for readjustment.

\*1: Check the High-pressure switch indication.

\*2: Check the Low- pressure switch indication.

### 8.3 The unit is working, but not cooling and heating sufficiently (Both blower and compressor are working)

WHAT TROUBLED	COMPLAINTS	HOW TO CHECK	REMEDY
Load	Much heat load	Heat load increased. Window or door has many cracks or gaps.	Do necessary disposal respectively.
Air flow	Obstacle disturbs Intake of uniform wind.	Checking	Correct it.
Short air volume	Reverse rotation of blower.	Checking	Correct it.
Refrigerant	Shortage in the charged refrigerant.	Coil inlet pipe is frosted	Replenish it. (Repair the leakage spot).
Air passage	Improper or foreign bodies	Checking	Correct or clear the foreign bodies.
Air filter	Clogged with dust	Checking	Cleaning

### 8.4 All the functions are performed normally, but very noisily and much vibratively.

WHAT TROUBLED	COMPLAINTS	HOW TO CHECK	REMEDY
Compressor	Liquid refrigerant flooding back from the evaporator.	<ul style="list-style-type: none"> <li>• Check for refrigerant over-charge.</li> <li>• Check to see if the intaking air temperature is extremely cold.</li> <li>• Check for insufficient air flow quantity.</li> </ul>	
	Compressor shipping bracket is not removed.	• Checking	• Remove the shipping bracket.
	Faulty discharge valve and suction valve.	• Checking	• Replace the compressor
Blower	Fan broken. Other materials intruded.	Checking	<ul style="list-style-type: none"> <li>• Repair or replace it.</li> <li>• Clear the other material</li> </ul>
Screws	Looseness or fail-off of screws	Checking	Repair

WHAT TROUBLED	COMPLAINTS	HOW TO CHECK	REMEDY
Electric troubles (Magnetic contactor)	Defective contact. Defective contact point. Rusting and faults in the iron core contact face. Defective contact of the operating switch.	Checking	Repair and clean or replace it.
Others	Improper installation	Checking	Correct it.

## 8.5 Trouble checking by protection devices

Fault	Cause	Check/Corrective Action
High Discharge	Condenser cooling air extremely hot or insufficient air flow through the condenser	1. Check the operation of the outdoor motor. 2. Check discharge and suction, air circulation.
	Inside of the condenser tube is clogged.	Clean condenser coil.
	Air in the refrigeration cooling cycle.	Purge air from the cycle.
	Suction pressure is higher than standard.	See "High Suction Pressure".
Low Discharge	Faulty discharge valves or suction valves of the compressor.	1. Check unit operation input 2. Check the suction pressure.
	Refrigerant low-charge or leakage.	Add refrigerant: repair leakage if any.
	Suction pressure is lower than standard.	See "Low Suction Pressure".
High Suction Pressure	Intake air extremely hot or excessive air flow through the evaporator coil.	1. Check fresh air, intake or check for leakage of the return air. 2. Check air flow quantity.
	Refrigerant over-charge.	Purge the refrigerant.
	Faulty discharge valve or suction valve of the compressor.	Check the operating input.
	Discharge pressure is higher than standard	See "High discharge Pressure".
Low Suction Pressure	Intake air extremely cold or insufficient air flow through the evaporator coil.	1. Check air flow quantity. 2. Check air filter. 3. Check evaporator coil frosting
	Refrigerant short-charge or leakage.	Add refrigerant, repair leakage, if any.
	Restricted liquid in the suction line.	Check the capillary tube and the strainer.

Fault	Cause	Check/Corrective Action
	Discharge pressure is lower than standard.	See "Low Discharge Pressure".
	Single or three phases running.	Check the power supply line and the contactor.
	High or low voltage or phase unbalance.	Check the voltage and phase unbalance.
Internal Thermostat Cut-Off	Refrigerant short charge or leakage.	Add refrigerant, repair leakage, if any.
	Compressor frequently stops and starts.	Check thermistor operation, or any other cause for frequent stop and start operation.
	Discharge and suction pressure are extremely high.	See "High Discharge Pressure" or "High Suction Pressure".
Overcurrent Relay for Compressor Cut-Off	High or low voltage, or phase unbalance.	Check the voltage and phase unbalance.
	Single or three phases running	Check the power supply line and the contact.
	Faulty compressor motor.	Check electric resistance among the compressor terminals, and from the terminals to ground.
	Loose connections.	Check the electric connections.
	Compressor frequently stops and starts.	Check the operation of the thermistor, or any other cause for frequent stop.
Overcurrent Relay for Fan Motor Cut-Off	High or low voltage, or phase unbalance.	Check the voltage and electric wiring.
	Single or three phases running.	Check the power supply line and the contactor.
	Faulty fan motor.	Check the fan motor and wiring.
	Loose connection.	Check the electric connections.
	Faulty fan bearing.	Check repair or replace the bearing.
Fuse Blown	Loose connections.	Check the electric connections.
	Single or three phase running.	Check the power supply line.
	Faulty motor.	Check electric resistance among motor housing, and from the terminals to ground.
Disconnection and Faulty Contact	Disconnection.	1. Check the wires and connect where necessary. 2. Check the contact holding coil.
	Faulty contact.	Check the contact in the magnetic contact, the over-current relay, the pressure control switch, the operation switch, the auxiliary relay.

## 8.6 Electronic Parts Troubleshooting Guide

### 1) No cooling operation performed.

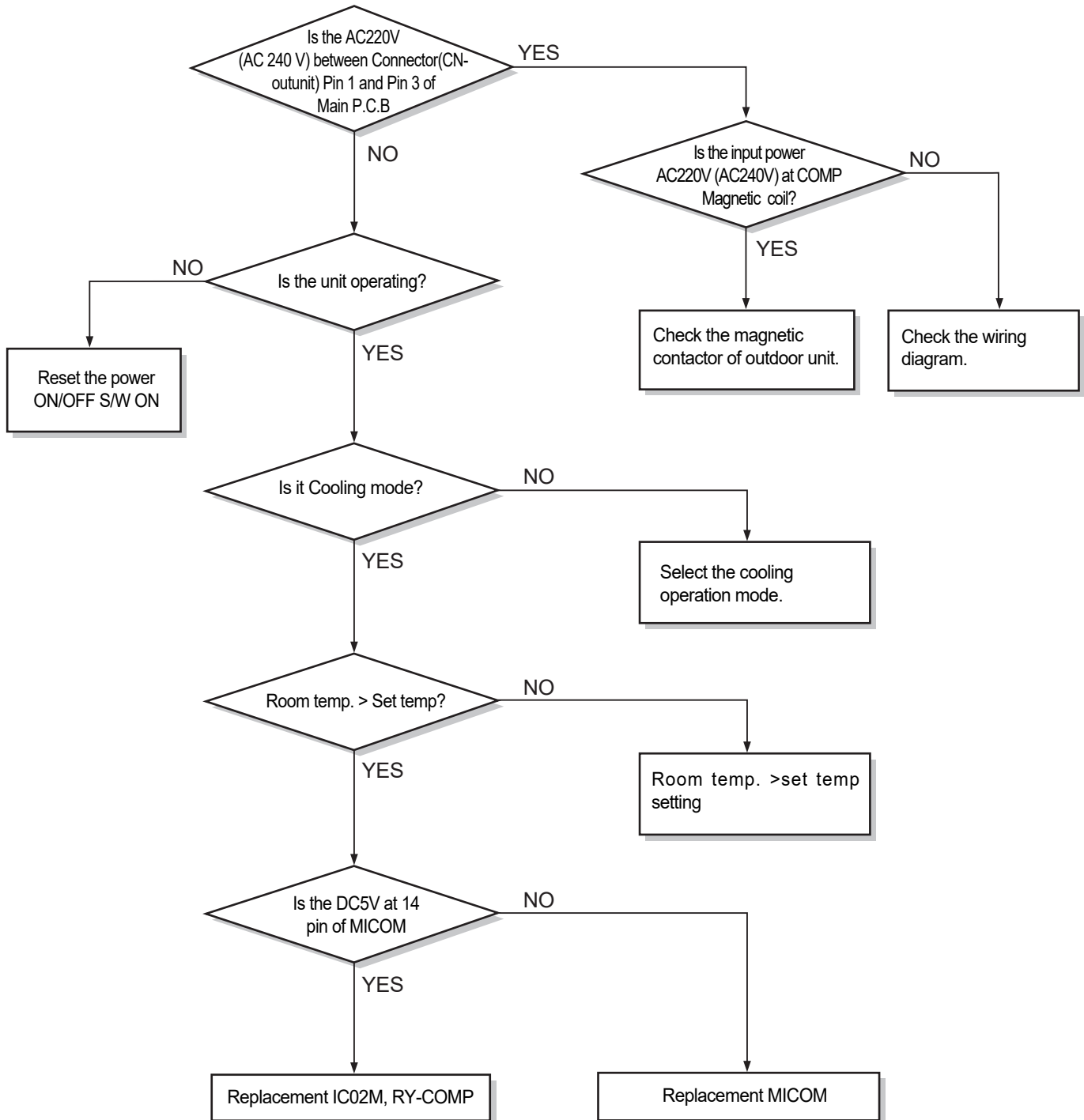



## 2) Indoor fan does not operate (LP-10091CL/XL)

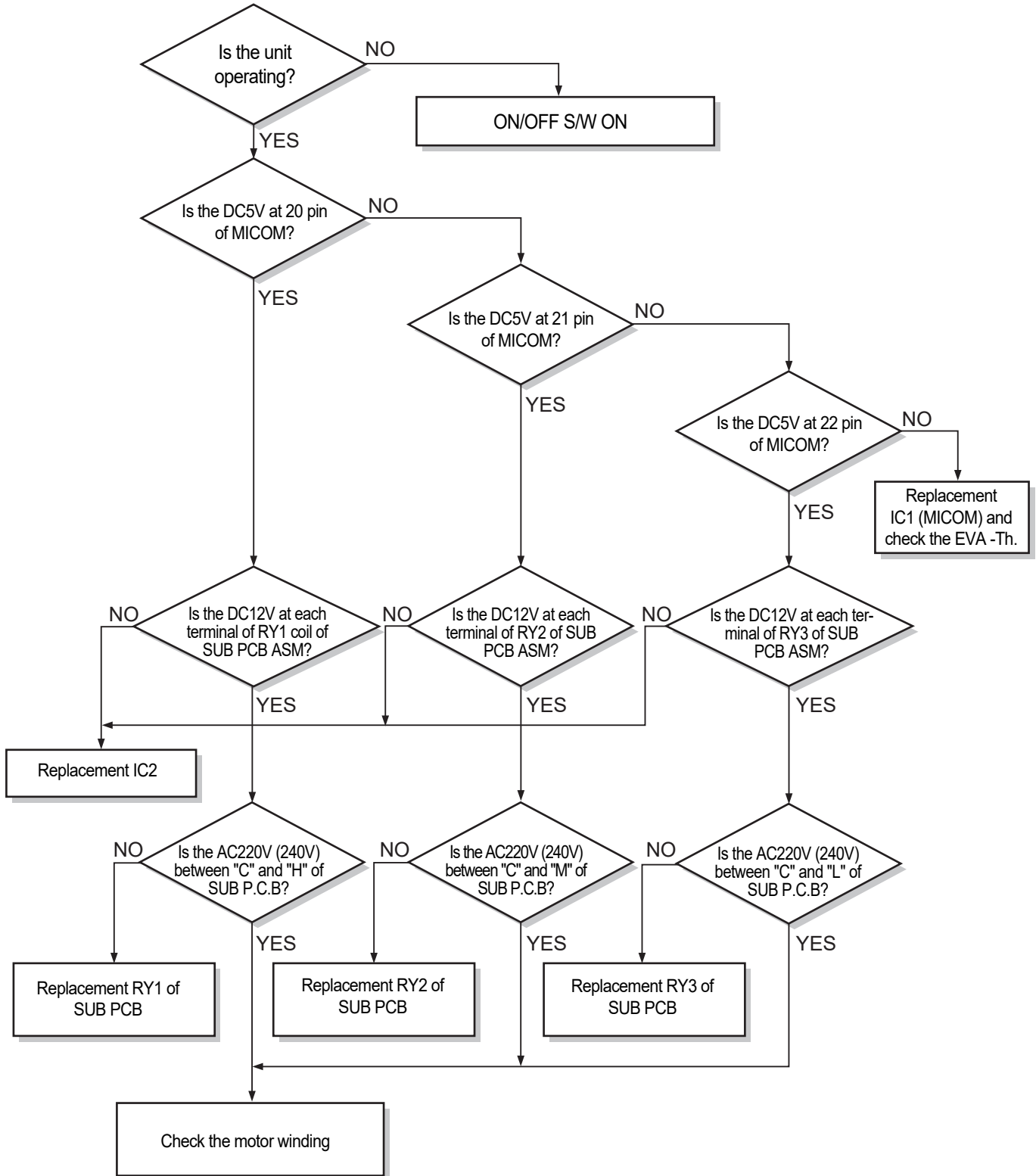

### 3) Indoor fan does not operate (LP-15091CL/XL)

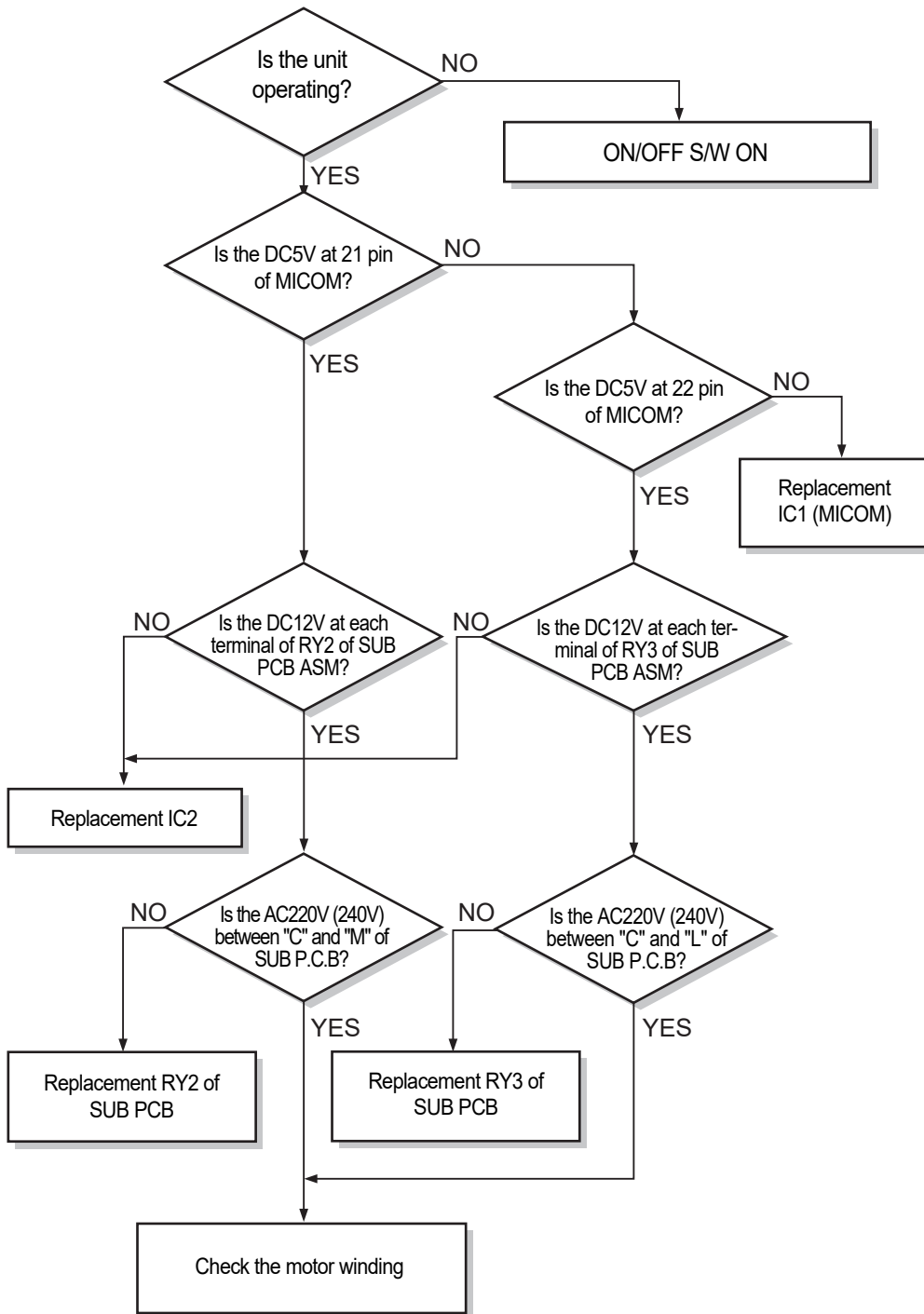

**4) The unit does not operate.**

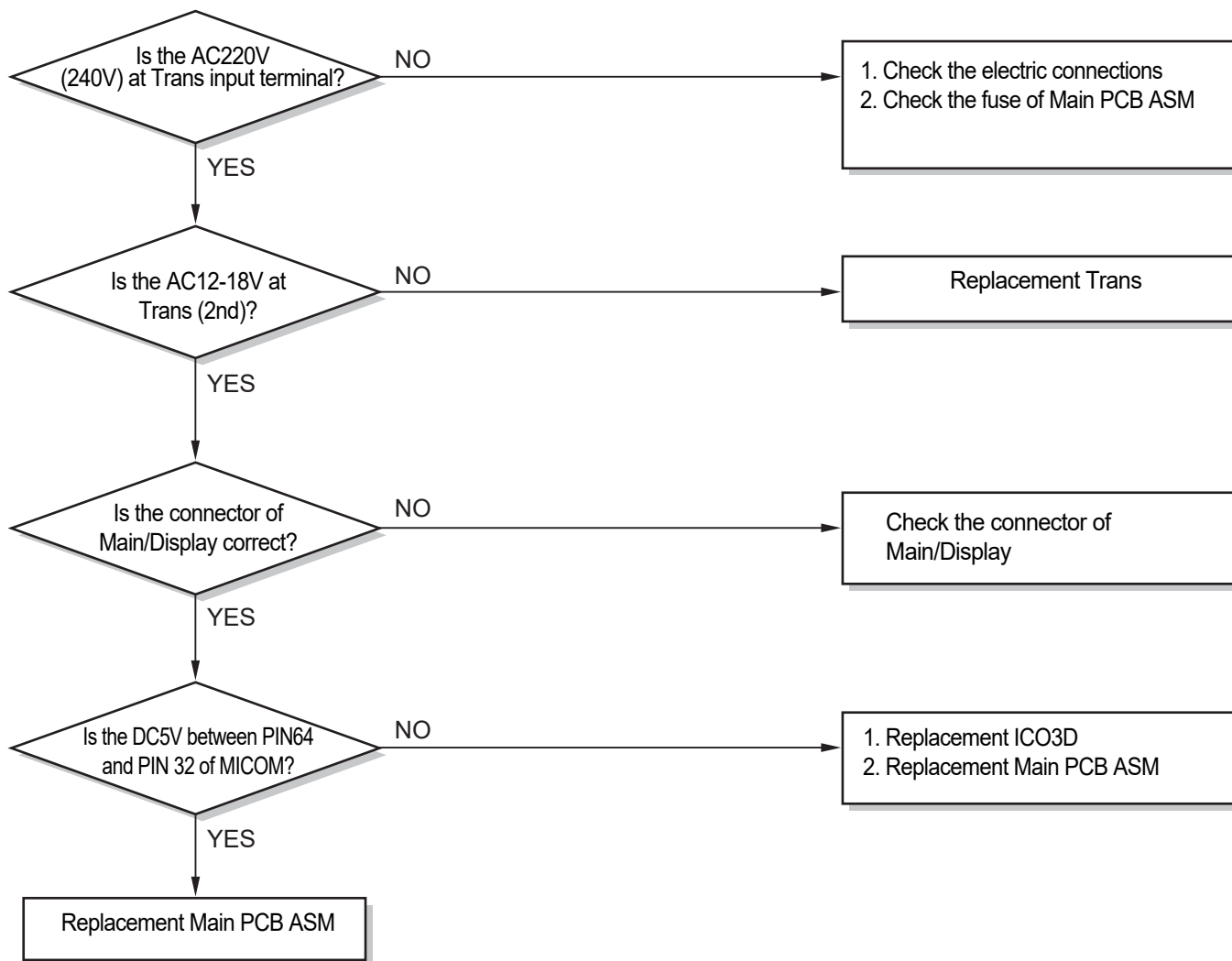

**6) Timer control does not operate.**

Replacement Micom

### 5) No heater operation works

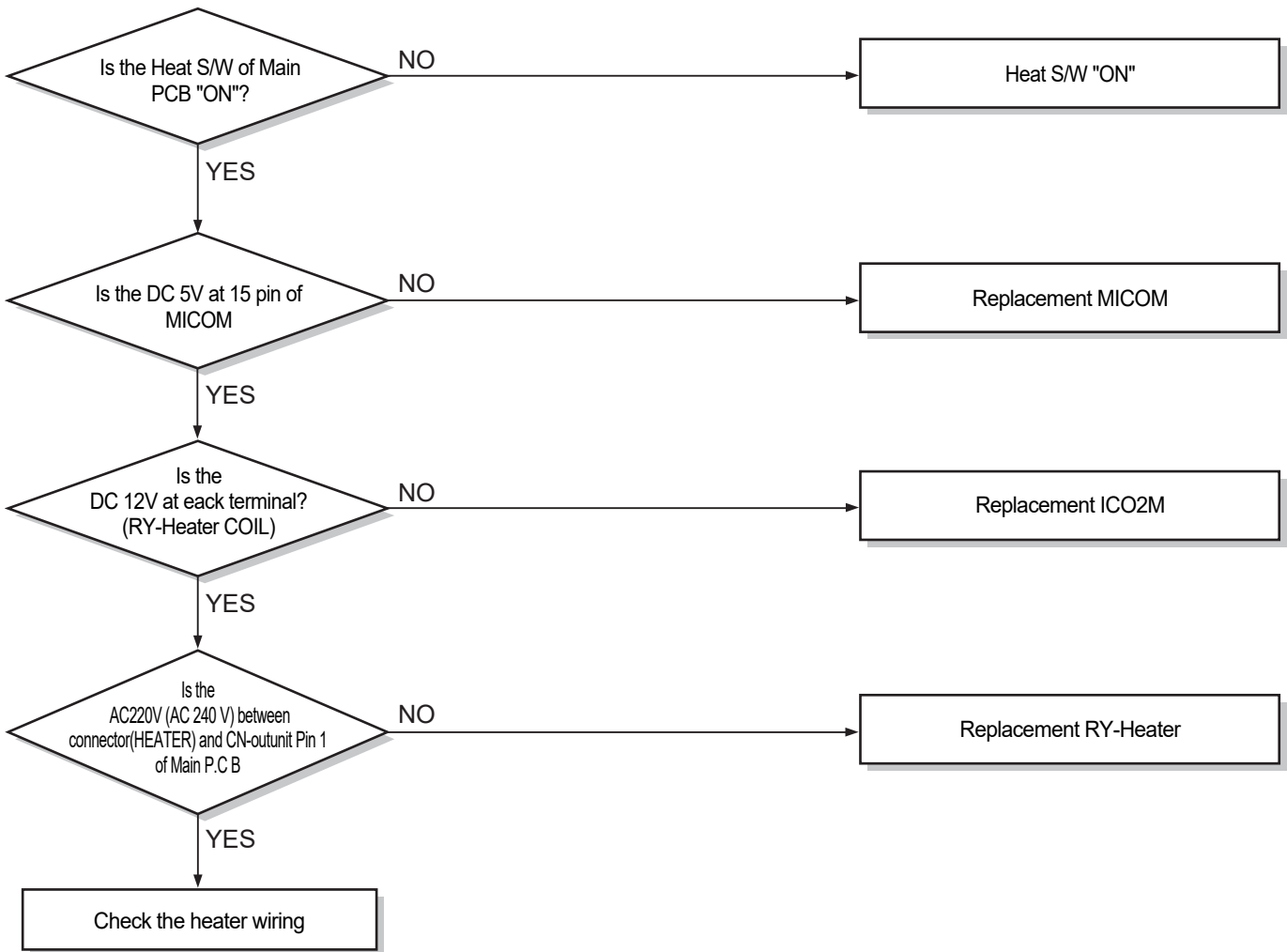



## 9.2 Display P.C.B ASSY

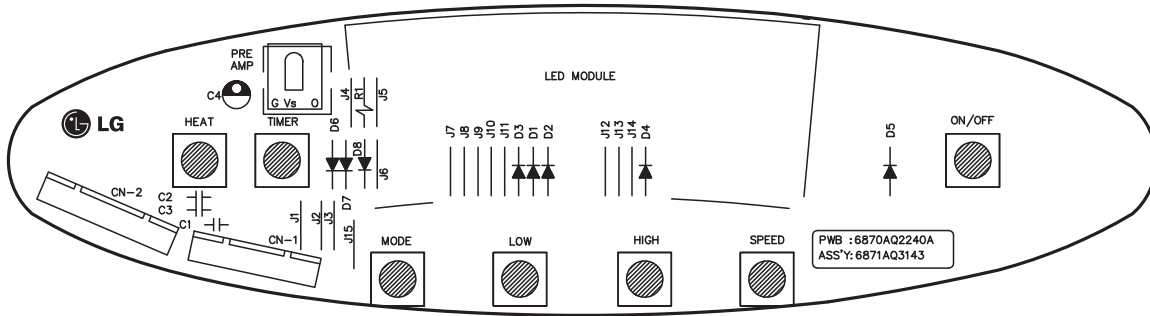

MODEL	DISPLAY PCB ASSY
LP-10091CL/XL LP-15091CL/XL	6871AQ3143Q

## 9.3 SUB P.C.B ASSY

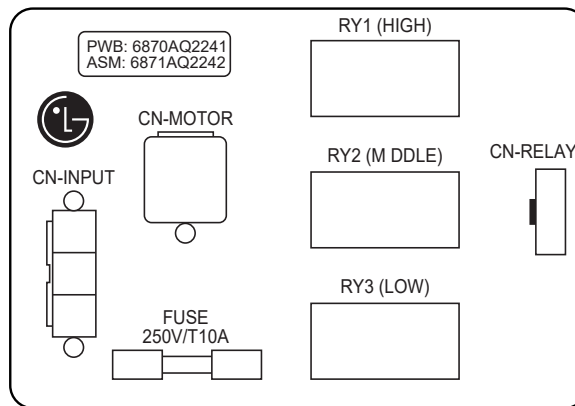

NO.	MODEL	SUB PCB ASSY
1	LP-10091CL	6871AQ2242A
2	LP-10091XL	6871AQ2242A

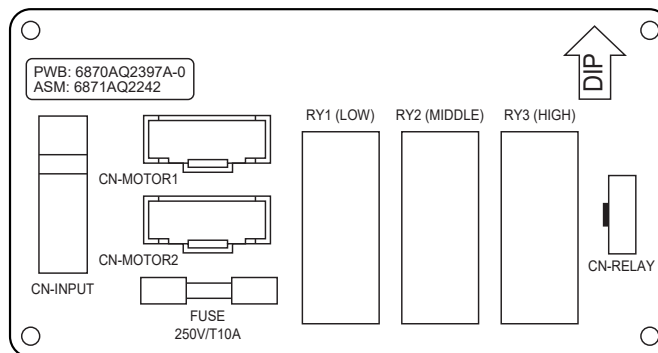

NO.	MODEL	SUB PCB ASSY
1	LP-15091CL	6871AQ2242B
2	LP-15091XL	6871AQ2242B

# 10. SCHEMATIC DIAGRAM

## LP-10091CL/XL, LP-15091CL/XL

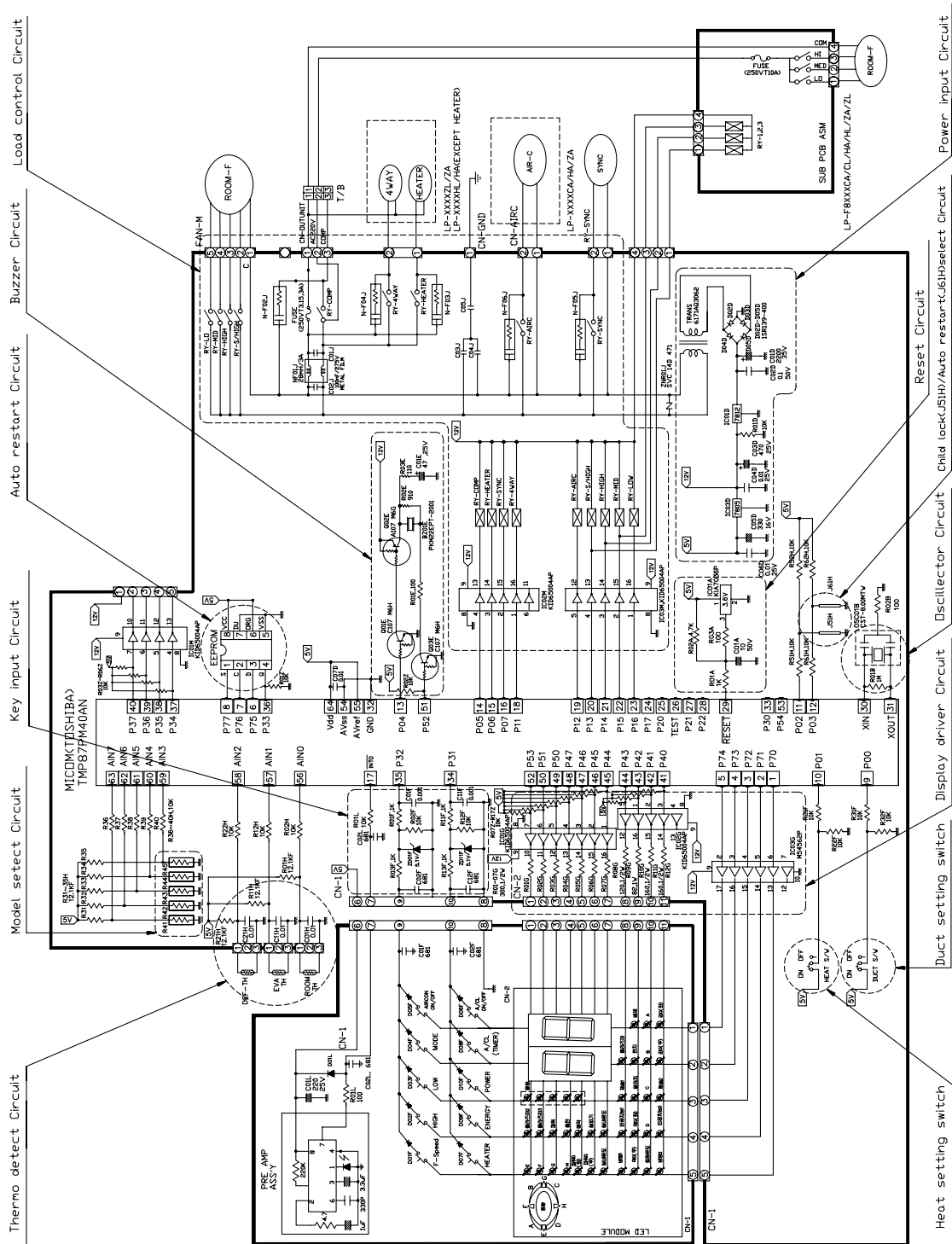

# 11. EXPLODED VIEW & REPLACEMENT PARTS LIST

## 11.1 Indoor Unit (LP-10091CL/10091XL)

### 1) Exploded View

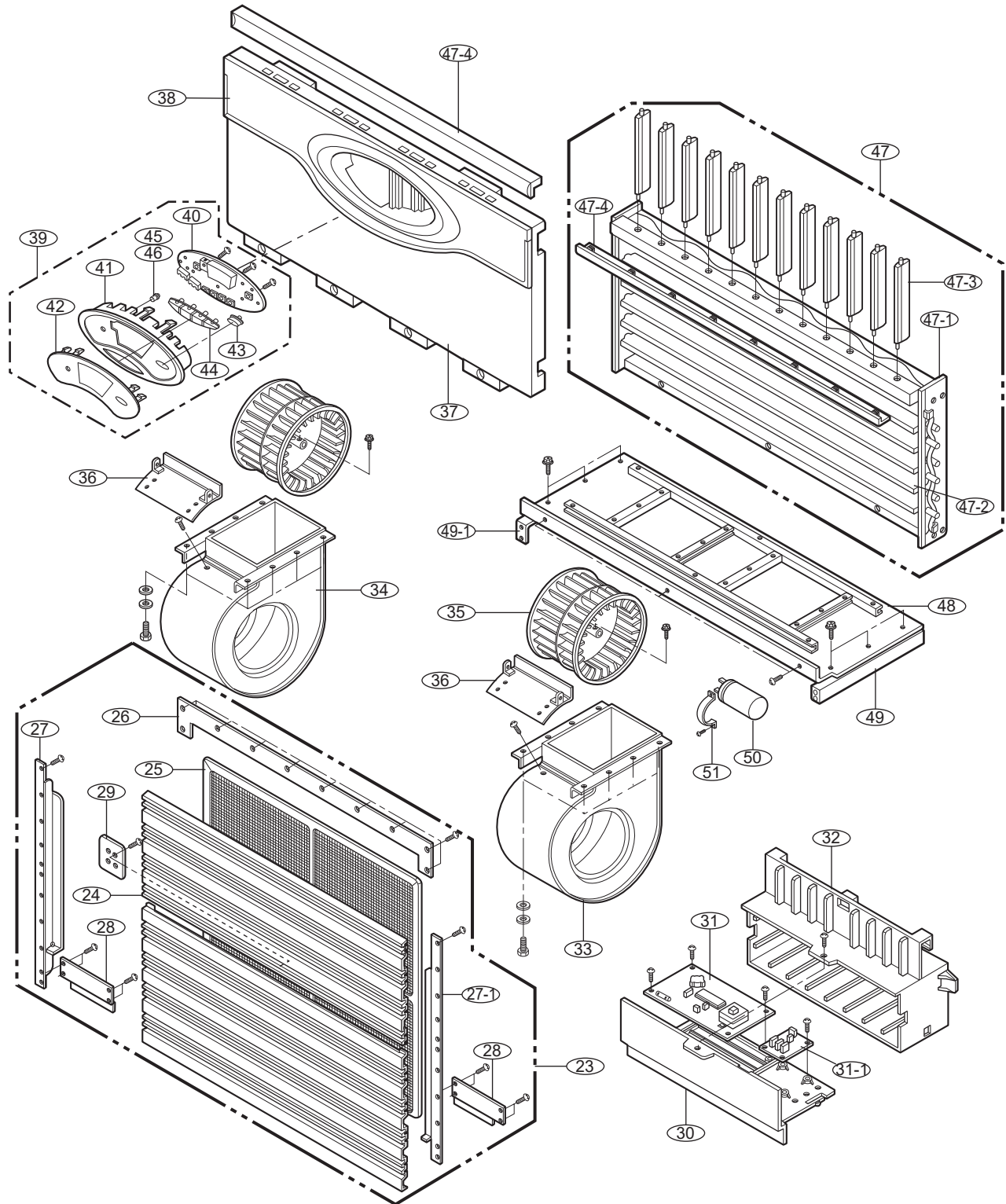



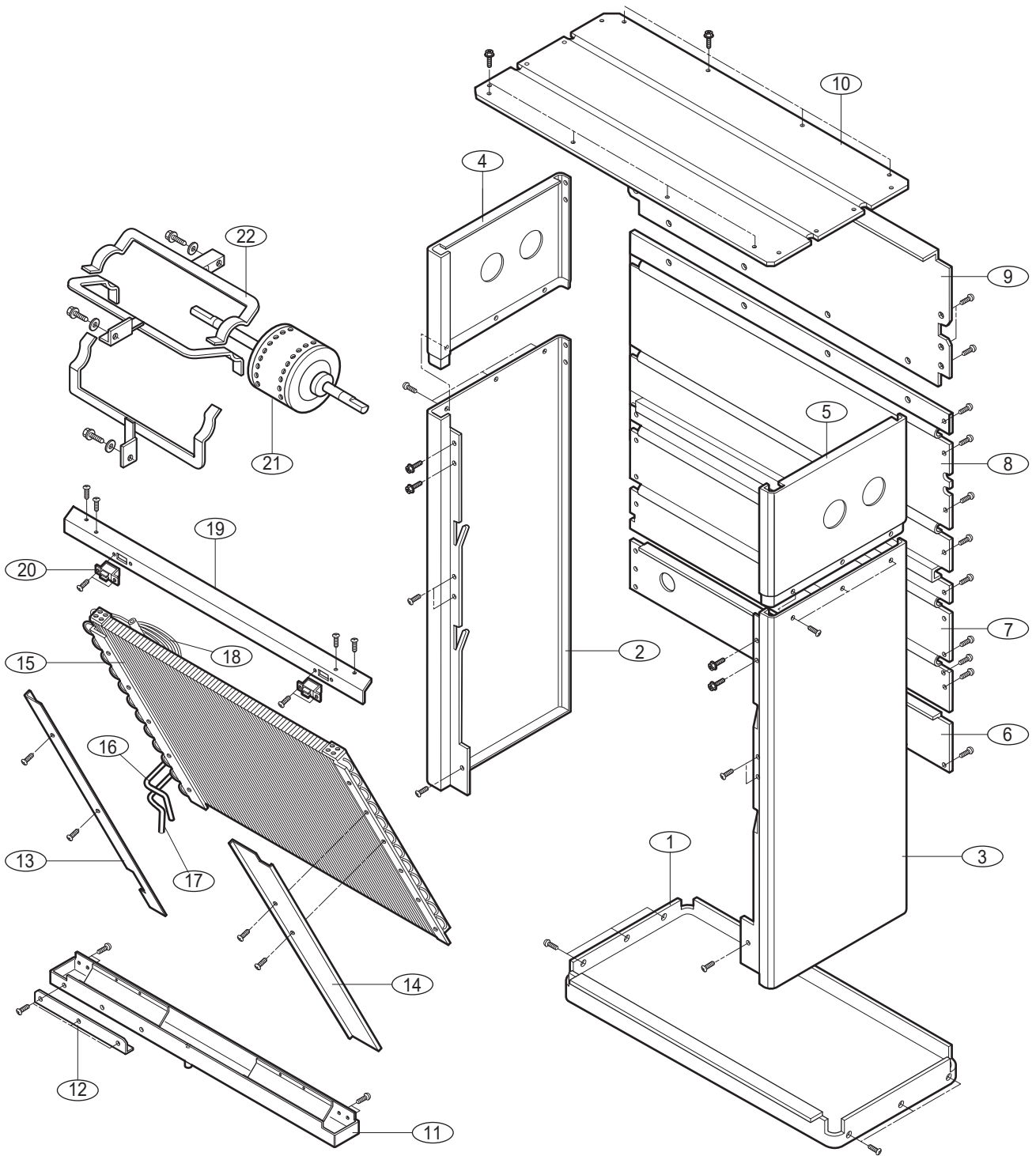

## 2) Exploded View of Electric Heater (LP-10091XL)

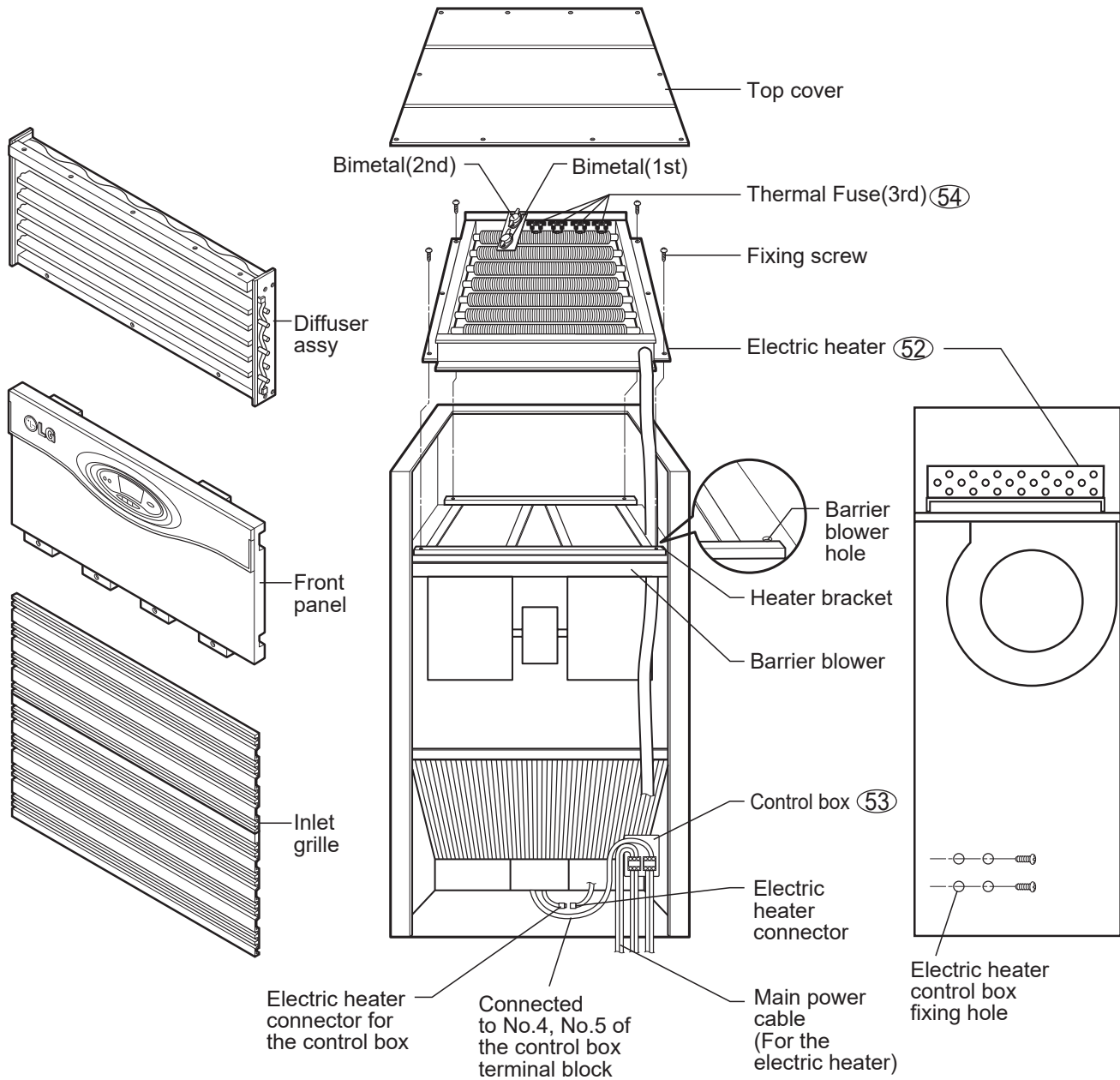

### Bimetal Type

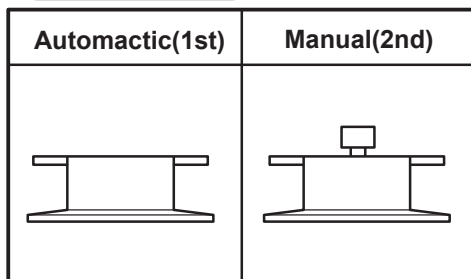

### Thermal Fuse Type

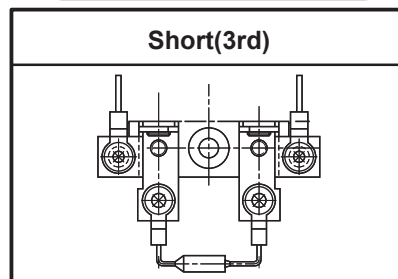

### 3) Replacement Parts List

No.	DESCRIPTION	PART NO.		Q'TY	REMARK
		LP-10091CL	LP-10091XL		
1	BASE PAN	3040AP2624P	3040AP2624P	1	
2	PANEL SIDE-L	3720AP1135P	3720AP1135P	1	
3	PANEL SIDE-R	3720AP1135Q	3720AP1135R	1	
4	PANEL SIDE U-L	3720AP2297R	3720AP2297R	1	
5	PANEL SIDE U-R	3720AP2297S	3720AP2297S	1	
6	PANEL REAR-L	3720AP2221A	3720AP2221A	1	
7	PANEL REAR-M1	3720AP2328A	3720AP2328A	1	
8	PANEL REAR-M2	3720AP2329A	3720AP2329A	1	
9	PANEL REAR	3720AP2268A	3720AP2268A	1	
10	TOP COVER	3720AP2197A	3720AP2197A	1	
11	DRAIN PAN ASS'Y	3081AP2381A	3081AP2381A	1	
12	BRACKET	4810AP3333P	4810AP3333P	1	
13	EVA. SIDE BRACKET	4810AP2296B	4810AP2296B	1	
14	EVA. SIDE BRACKET	4810AP2648A	4810AP2648A	1	
15	EVA. ASM	5420AP2380B	5420AP2380B	1	
16	TUBE ASS'Y	5211AP2678C	5211AP2678C	1	
17	TUBE ASS'Y	5211AP3959A	5211AP3959A	1	
18	CAPILLARY TUBE	3H01372R	3H01372R	15	
19	EVA. BRACKET	5420AP3302A	5420AP3302A	1	
20	DOOR MAGNET ASM	3A02221A	3A02221A	2	
21	MOTOR ASM	4681AP2411	4681AP2411	1	
22	MOTOR BRACKET	3G00788U	3G00788U	3	
23	INLET GRILLE ASM	5237AP2386B	5237AP2386B	1	
24	INLET GRILLE	3530AP1109A	3530AP1109A	2	
25	FILTER ASM	5231AP3330A	5231AP3330A	1	
26	BRACKET	5236AP3294Z	5236AP3294Z	1	
27	GUIDE FILTER	4974AP2225Z	4974AP2225Z	1	
27-1	GUIDE FILTER	4974AP2225Y	4974AP2225Y	1	
28	BRACKET	4810AP3298A	4810AP3298A	2	
29	BRACKET-M	4810AP4051A	4810AP4051A	1	
30	BOARD CONTROL	3500AP2293A	3500AP2293A	1	
31	MAIN PCB ASM	6871AQ0067R	6871AQ0067X	1	
31-1	SUB-PCB ASM	6871AQ2242A	6871AQ2242A	1	

No.	DESCRIPTION	PART NO.		Q'TY	REMARK
		LP-10091CL	LP-10091XL		
32	CONTROL BOX	4994AP2291A	4994AP2291A	1	
33	HOUSING ASS'Y	3661AP1139A	3661AP1139A	1	
34	HOUSING ASS'Y	3661AP1139B	3661AP1139B	1	
35	BLOWER ASS'Y	2A00578R	2A00578R	2	
36	CUT OFF ASM	4A00085A	4A00085A	2	
37	FRONT PANEL	3720AP1136P	3720AP1136P	1	
38	HOLDER DISPLAY	4930AP1133A	4930AP1133A	1	
39	CONTROLLER ASM	3545A20004D	3545A20004N	1	
40	DISPLAY PCB ASM	6871AQ3143Q	6871AQ3143Q	1	
41	BODY DISPLAY	3070AP2292K	3070AP2292K	1	
42	WINDOW DISPLAY	3790AP3936Q	3790AP7356C	1	
43	KNOB-P	4940AP3422C	4940AP3422C	1	
44	KNOB	4940A30006A	4940A30006A	1	
		4940A30006B	4940A30006B	1	
		4940A30006C	4940A30006C	1	
		4940A30006D	4940A30006D	1	
45	KNOB-C.C	4940AP3166E	4940AP3166E	1	
46	KNOB, HEATER	-	4940AP3326E	1	
47	DIFFUSER ASS'Y	3023AP2387B	3023AP2387B	1	
47-1	DIFFUSER ASS'Y	3023AP2641P	3023AP2641P	1	
47-2	GRILLE	4A01317Z	4A01317Z	5	
47-3	GRILLE ASS'Y	3A00752Y	3A00752Y	12	
47-4	DECORATION	3508AP3328B	3508AP3328B	2	
48	BARRIER BLOWER	4791AP2300Q	4791AP2300Q	1	
49	RACK BARRIER	4790AP3217A/B	4790AP3217A/B	1	
50	CAPACITOR	2A00986S	2A00986S	1	
51	CLAMP CAPACITOR	4H00930D	4H00930D	1	
52	ELECTRIC HEATER	-	5300AP1237C	1	
53	CONTROL BOX, HEATER	-	3A01924L	1	
54	THERMAL FUSE	-	6901A30001Z	2	

# 11.2 Indoor Unit (LP-15091CL/15091XL)

## 1) Exploded View

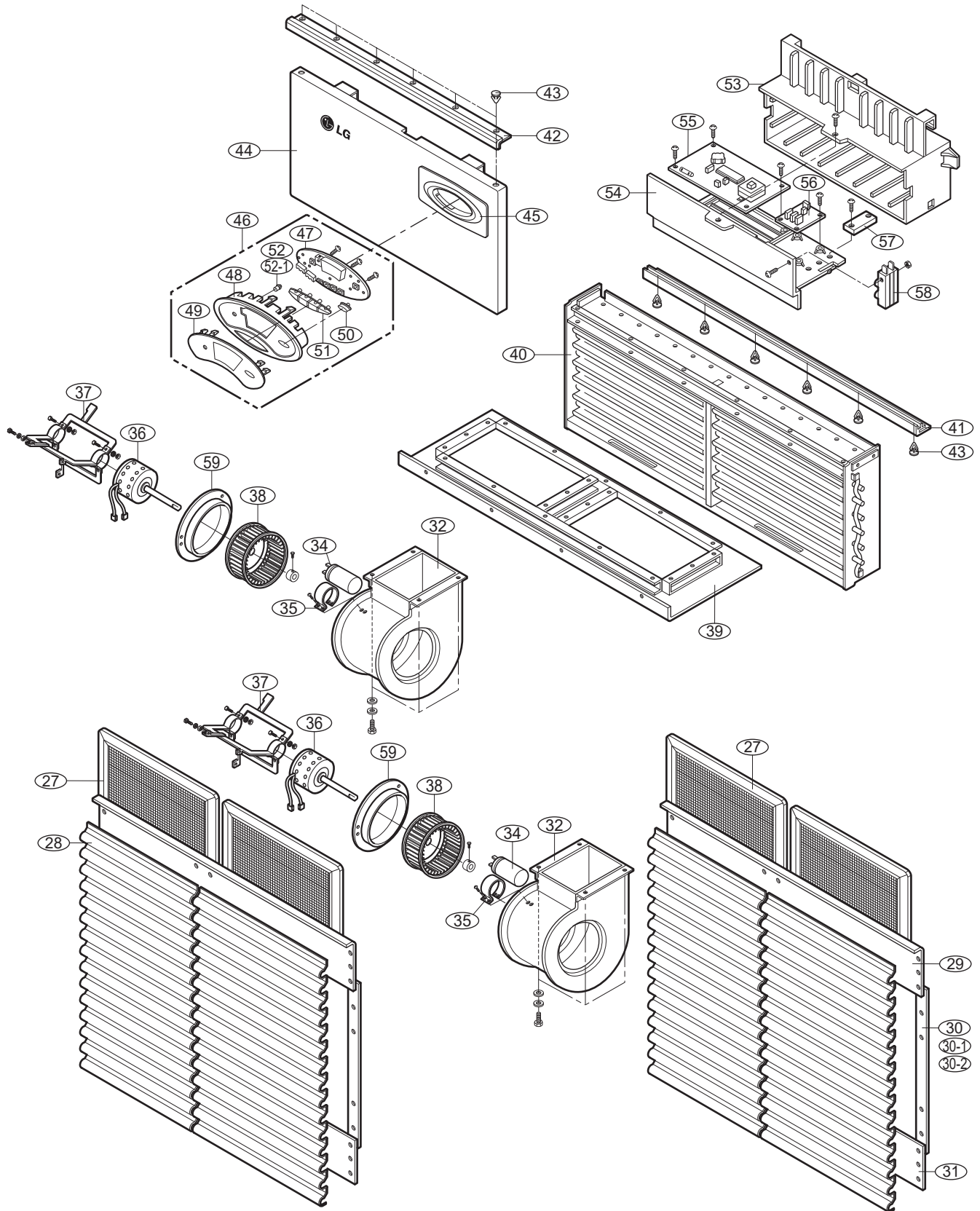

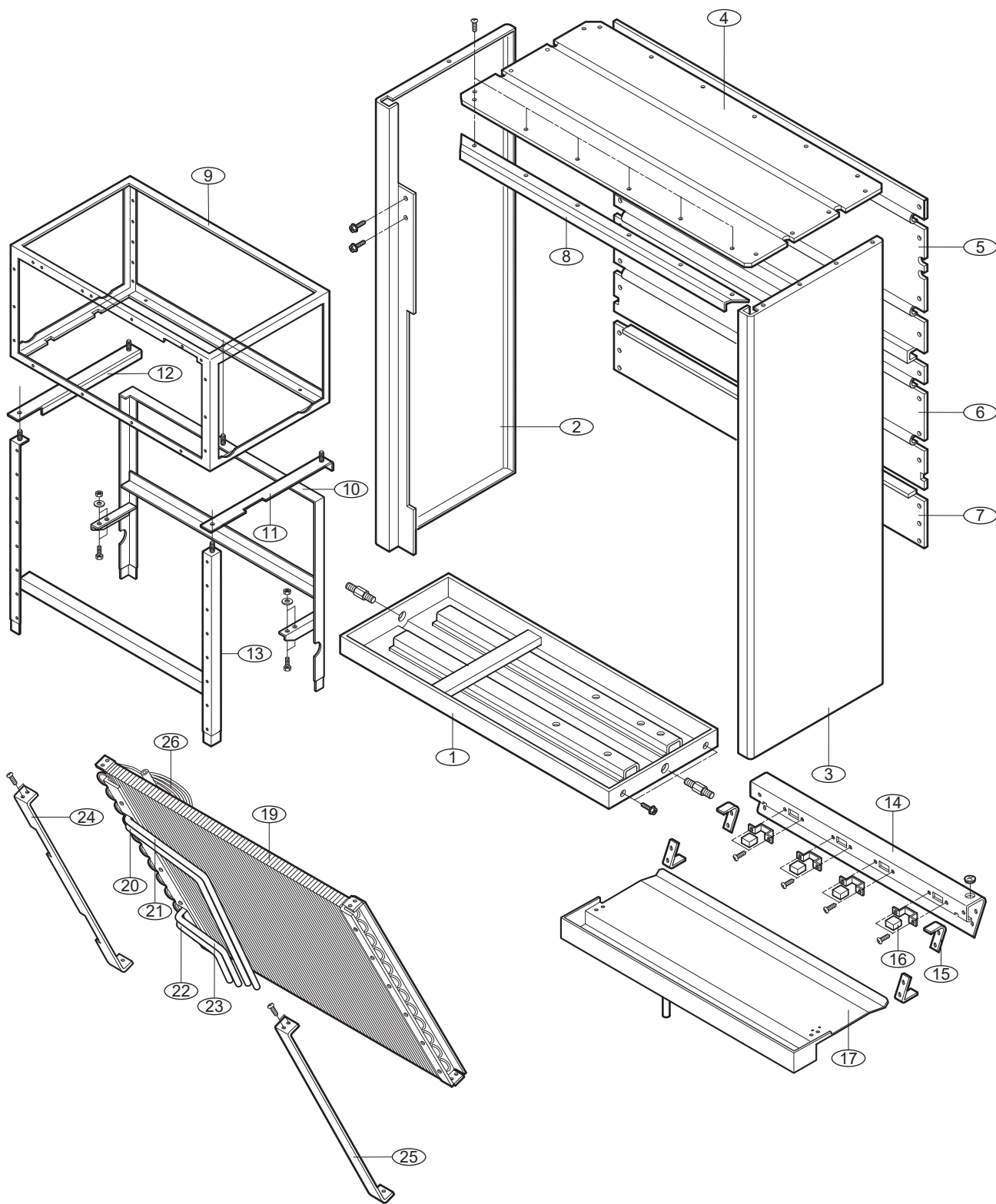

## 2) Exploded View of Electric Heater (LP-15091XL)

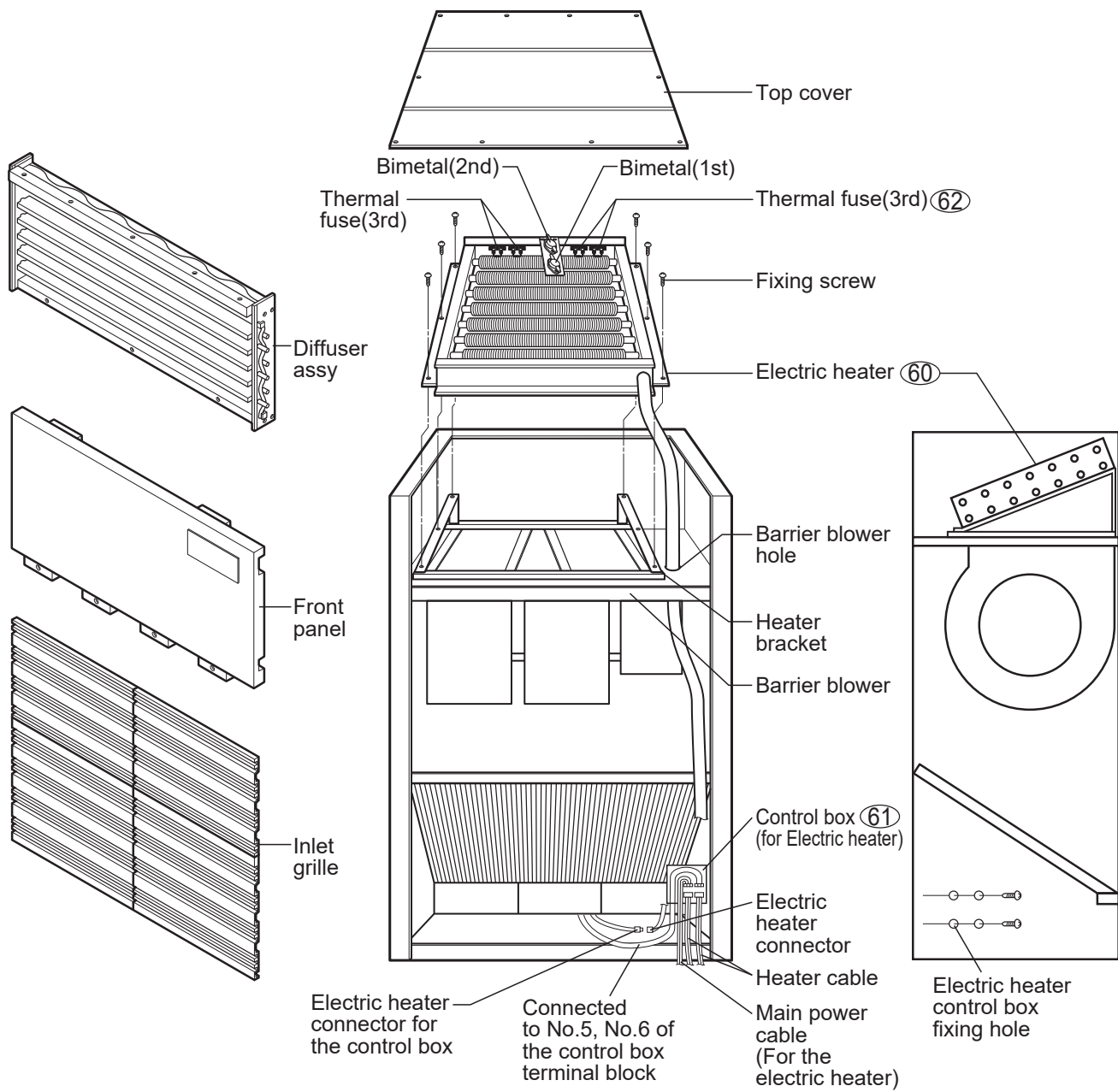

### Bimetal Type

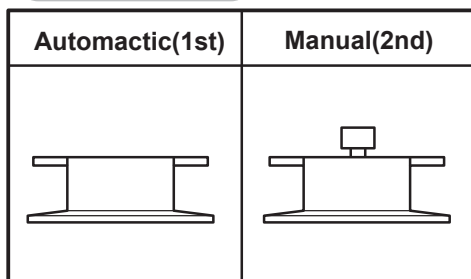

### Thermal Fuse Type

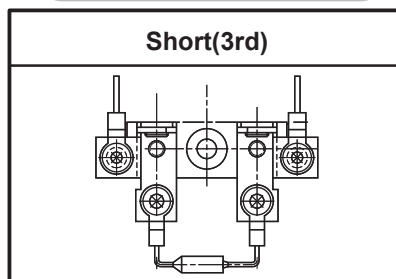

### 3) Replacement Parts List

No.	DESCRIPTION	PART NO.		Q'TY	REMARK
		LP-15091CL	LP-15091XL		
1	BASE	2A00410Q	2A00410Q	1	
2	PANEL SIDE-L	3A02242G	3A02242L	1	
3	PANEL SIDE-R	3A02242M	3A02242M	1	
4	TOP COVER	3A02244D	3A02244C	1	
5	PANEL REAR-B	3A02263C	3A02263B	1	
6	PANEL REAR-M	3A02260B	3A02260B	1	
7	PANEL REAR-L	3A02317B	3A02317B	1	
8	GRILLE TOP COVER	4A01598Q	4A01598Q	1	
9	BEAM-B ASSY	2A00435Q	2A00435Q	1	
10	ANGLE REAR ASSY	3001AP1718P	3001AP1718P	1	
11	BRACKET SIDE W. ASSY	3A01431R	3A01431R	1	
12	BRACKET SIDE W. ASSY	3A01431S	3A01431S	1	
13	ANGLE FRONT ASSY	2A00412R	2A00412R	1	
14	SUPPORT EVAP. ASSY	3A01420C	3A01420C	1	
15	BRACKET-U.L	4810AP4208P	4810AP4208P	4	
16	DOOR MAGNET. ASSY	3A02221A	3A02221A	4	
18	DRAIN PAN ASSY	3087A20001Q	3087A20001Q	1	
19	EVAP. COIL ASSY	5421AP2973A	5421AP2973A	1	
20	TUBE MAINFOLD OUT ASSY-1	5211AP2852A	5211AP2852A	1	
21	TUBE DISCHARGE-1	5211AP7320E	5211AP7320E	1	
22	TUBE MAINFOLD OUT ASSY-2	5211AP2853A	5211AP2853A	1	
23	TYBE DISCHARGE-2	5211AP7320F	5211AP7320F	1	
24	BRACKET EVAP-L	4810AP2822A	4810AP2822A	1	
25	BRACKET EVAP-R	4810AP2822B	4810AP2822B	1	
26	TYBE CAPILLARY	3E92334N	3E92334N	17	
27	FILTER ASSY	3A01299K	3A01299K	4	
28	GRILLE INLET	1A00111C	1A00111C	8	
29	SUPPORT GRILLE-U	3A01493Q	3A01493Q	1	
30	GUIDE FILTER	3A01338E	3A01338E	2	
30-1	GUIDE FILTER	3A01338F	3A01338F	2	
30-2	GUIDE FILTER	4974AP2145C	4974AP2145C	2	
31	SUPPORT GRILLE-L	3A01494Q	3A01494Q	2	
32	HOUSING ASSY	3G00128A	3G00128A	2	
34	CAPACITOR	2A00986T	2A00986T	2	



No.	DESCRIPTION	PART NO.		Q'TY	REMARK
		LP-15091CL	LP-15091XL		
35	CLAMP CAPACITOR	4G00107C	4G00107C	2	
36	MOTOR ASSY	4681AP2824A	4681AP2824A	2	
37	BRACKET, MOTOR	3G00788T	3G00788T	6	
38	BLOWER, WHEEL.	2A00578D	2A00578D	2	
39	BARRIER W. ASSY	4791AP2833P	4791AP2833P	1	
40	DIFFUSER ASSY	2A01107B	2A01107B	1	
41	DECO UPPER	3A01393A	3A01393A	1	
42	DECO. LOWER.	3A02136B	3A02136B	1	
43	HOLDER PIN	3A01407A	3A01407A	16	
44	FRONT PANEL	3720AP1182P	3720AP1182P	1	
45	DISPLAY, HOLDER	4930AP1285A	4930AP1285A	1	
46	CONTROLLER ASSY	3545A20004D	3545A20004N	1	
47	DISPLAY PCB ASSY	6871AQ3143Q	6871AQ3143Q	1	
48	BODY. DISPLAY	3070AP2292K	3070AP2292K	1	
49	WINDOW DISPLAY	3790AP3936Q	3790AP7356C	1	
50	KNOB-P	4940AP3422C	4940AP3422C	1	
51	KNOB	4940A30006A	4940A30006A	1	
51-1	KNOB	4940A30006B	4940A30006B	1	
51-2	KNOB	4940A30006C	4940A30006C	1	
51-3	KNOB	4940A30006D	4940A30006D	1	
52	KNOB-C.C	4940AP3166E	4940AP3166E	1	
52-1	KNOB-HEATER	-	4940AP3326E	1	
53	CONTROL BOX	4944AP2293A	4944AP2293A	1	
54	BOARD CONTROL	3500AP2291A	3500AP2291A	1	
55	MAIN PCB ASSY	6871A20082B	6871A20082C	1	
56	SUB PCB ASSY	6871AQ2242B	6871AQ2242B	1	
57	TERMINAL BLOCK	4G00103B	4G00103B	1	
58	TIMER	3A02380A	3A02380A	1	
59	ORIFICE ASSY	3G00129A	3G00129A	2	
60	ELECTRIC HEATER	-	5301A10002E	1	
61	CONTROL BOX, HEATER	-	4995AP2575H	1	
62	THERMAL FUSE	-	6901A30001S	6	

# 11.3 Indoor Unit (LP-20091CL/20091XL)

## 1) Exploded View

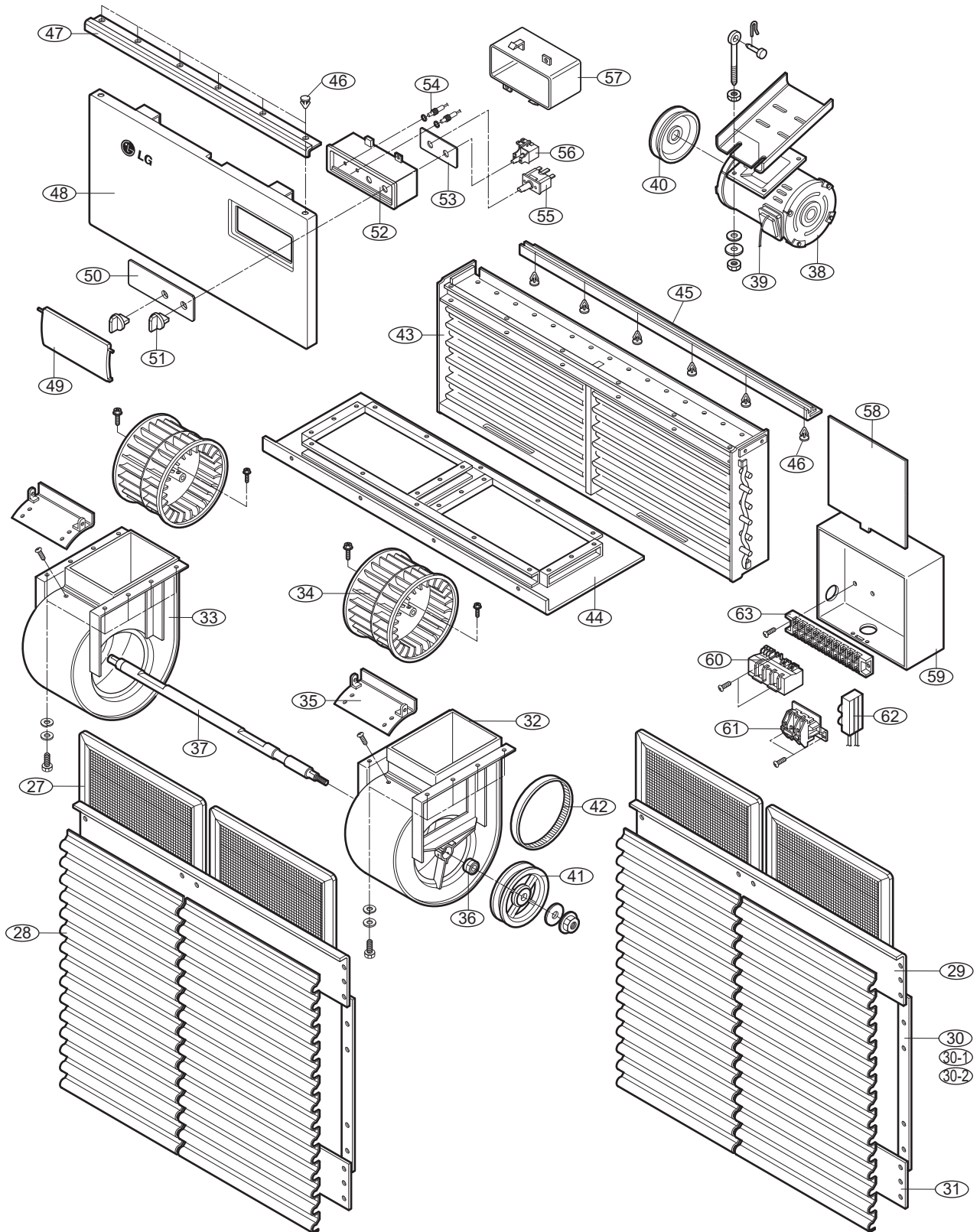

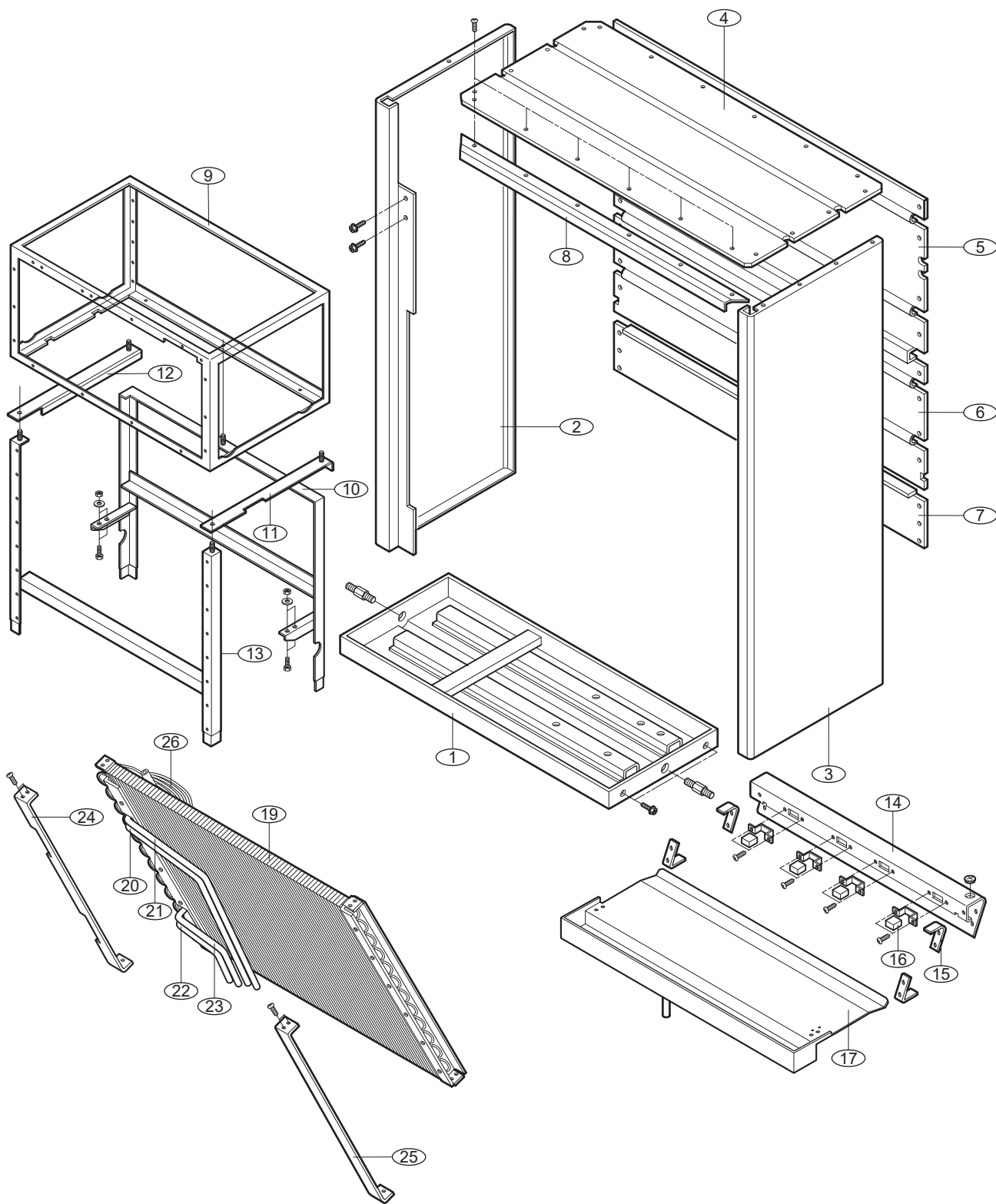

## 2) Exploded View of Electric Heater (LP-20091XL)

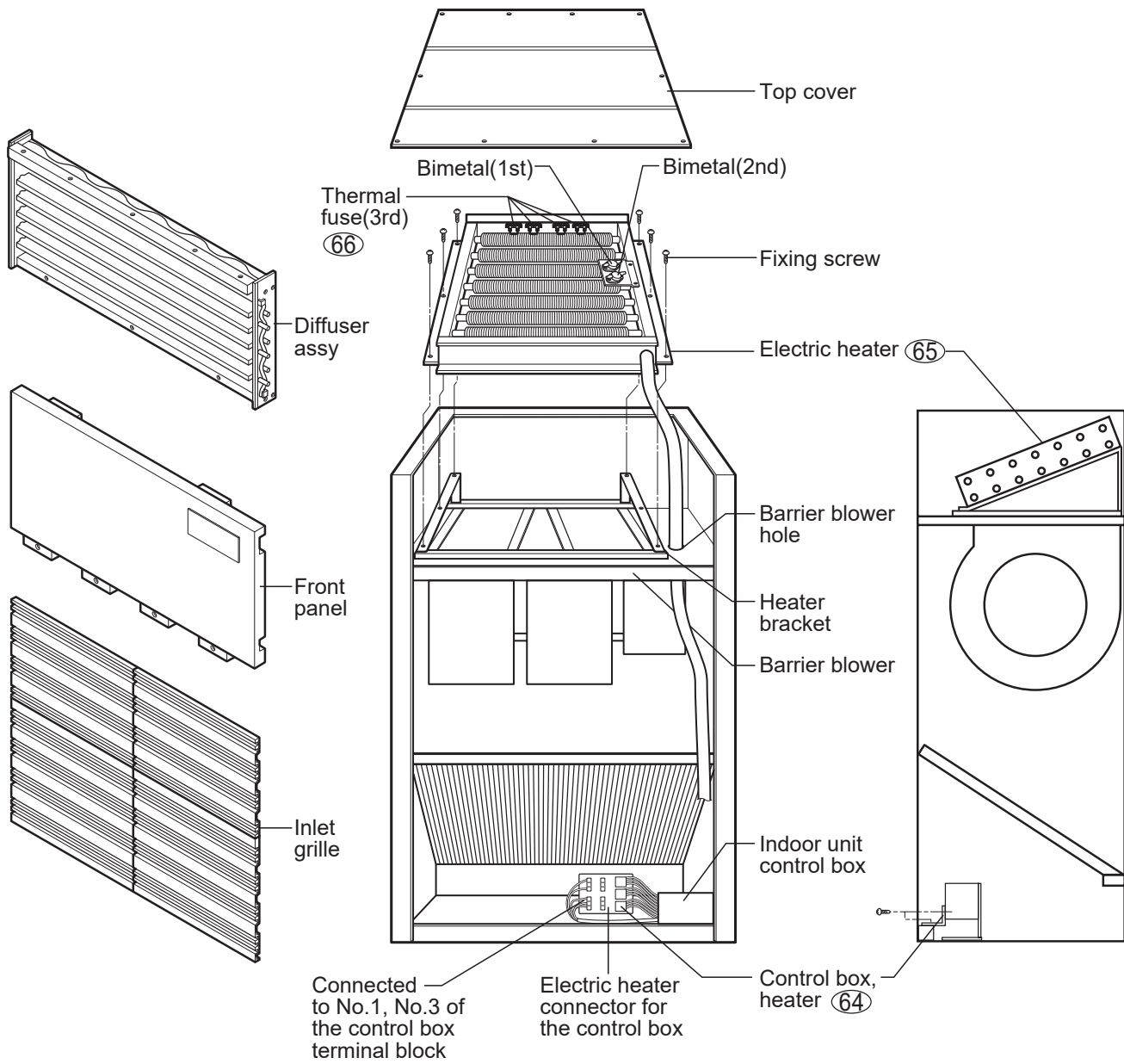

### Bimetal Type

Automatic(1st)

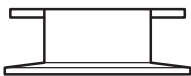

Manual(2nd)

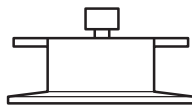

### Thermal Fuse Type

Short(3rd)

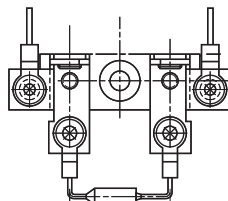

### 3) Replacement Parts List

No.	DESCRIPTION	PART NO.		Q'TY	REMARK
		LP-20091CL	LP-20091XL		
1	BASE	2A00410Q	2A00410Q	1	
2	PANEL SIDE-L	3A02242G	3A02242L	1	
3	PANEL SIDE-R	3A02242H	3A02242V	1	
4	TOP COVER	3A02244D	3A02244C	1	
5	PANEL REAR-B	3A02263C	3A02263B	1	
6	PANEL REAR-M	3A02260B	3A02260B	1	
7	PANEL REAR-L	3A02317B	3A02317B	1	
8	GRILLE TOP COVER	4A01598Q	4A01598Q	1	
9	BEAM-B ASSY	2A00435Q	2A00435Q	1	
10	ANGLE REAR ASSY	3001AP1318P	3001AP1318P	1	
11	BRACKET. SIDE W. ASSY	3A01431R	3A01431R	1	
12	BRACKET. SIDE W. ASSY	3A01431S	3A01431S	1	
13	ANGLE FRONT ASSY	2A00412R	2A00412R	1	
14	SUPPORT EVAP. ASSY	3A01420C	3A01420C	1	
15	BRACKET-U.L	4810AP4208P	4810AP4208P	4	
16	DOOR MAGNET. ASSY	3A02221A	3A02221A	4	
17	DRAIN PAN ASSY	3087A20001Q	3087A20001Q	1	
19	EVAP. COIL ASSY	5421AP2973A	5421AP2973A	1	
20	TUBE ASSY(MAINFOLD OUT-1)	5211AP2852C	5211AP2852C	1	
21	TUBE ASSY(DISCHARGE-1)	5211AP7320E	5211AP7320E	1	
22	TUBE ASSY(MAINFOLD OUT-2)	5211AP2853C	5211AP2853C	1	
23	TUBE ASSY(DISCHARGE-2)	5211AP7320F	5211AP7320F	1	
24	BRACKET EVAP-L	4810AP2822A	4810AP2822A	1	
25	BRACKET EVAP-R	4810AP2822B	4810AP2822B	1	
26	TUBE CAPILLARY	5424AP3074F	5424AP3074F	17	
27	FILTER ASSY	3A01299K	3A01299K	4	
28	GRILLE INLET	1A00111C	1A00111C	8	
29	SUPPORT GRILLE-U	3A01493Q	3A01493Q	2	
30	GUIDE FILTER	3A01338E	3A01338E	2	
30-1	GUIDE FILTER	3A01338F	3A01338F	2	
30-2	GUIDE FILTER	4974AP2145C	4974AP2145C	2	
31	SUPPORT GRILLE-L	3A01494Q	3A01494Q	2	
32	HOUSING ASSY	2A00214R	2A00214R	1	
33	HOUSING ASSY	2A00214S	2A00214S	1	

No.	DESCRIPTION	PART NO.		Q'TY	REMARK
		LP-20091CL	LP-20091XL		
34	BLOWER WHEEL ASSY	2A00578K	2A00578K	2	
35	CUT OFF	3G00013D	3G00013D	2	
36	BEARING	4G00333A	4G00333A	2	
37	SHAFT	3A00910A	3A00910A	1	
38	MOTOR	2A00187C	2A00187C	1	
39	CONDUCTOR ASSY	3A00274B	3A00274B	1	
40	PULLEY, MOTOR	3A00916P	3A00916P	1	
41	PULLEY-B	3A00915Q	3A00915Q	1	
42	V-BELT	4A01316C	4A01316C	4	
43	DIFFUSER ASSY	2A01107B	2A01107B	1	
44	BARRIER W. ASSY	2A00437Q	2A00437R	1	
45	DECO UPPER	3A01393A	3A01393A	1	
46	HOLDER PIN	3A01407A	3A01407A	16	
47	DECO LOWER	3A02136B	3A02136B	1	
48	PANEL. FRONT	3A02137Q	3A02137Q	1	
49	PANEL DOOR	3A01941B	3A01941B	1	
50	ESCUTCHEON	3A01987S	3A01987T	1	
51	KNOB ASSY	4H01519A	4H01519A	2	
52	PANEL, CONTROL	2A00933B	2A00933B	1	
53	BRACKET CONTROL	4A01575A	4A01575A	1	
54	LAMP, NEON ASSY	3G00027D	3G00027G	2	
55	ROTARY S/W	2A00237A	2A00237A	1	
56	THERMOSTAT	3A00963A	3A00963A	1	
57	COVER CONTROL	3A01939A	3A01939A	1	
58	COVER C.B	3A01491A	3A01491A	1	
59	CONTROL BOARD	3A02463B	3A02463A	1	
60	PROTECTION RELAY	2A00999F	2A00999F	1	
61	MAGNETIC CONTACTOR	2A00987C	2A00987C	1	
62	TIMER	3A02380A	3A02380A	1	
63	TERMINAL BLOCK	3A00093A	3A00093A	1	
64	CONTROL BOX, HEATER	-	4995AP2575J	1	
65	ELECTRIC HEATER	-	5301A10002F	1	
66	THERMAL FUSE	-	6901A30001T	6	

# 11.4 Outdoor Unit (LP-10091CL/10091XL)

## 1) Exploded View

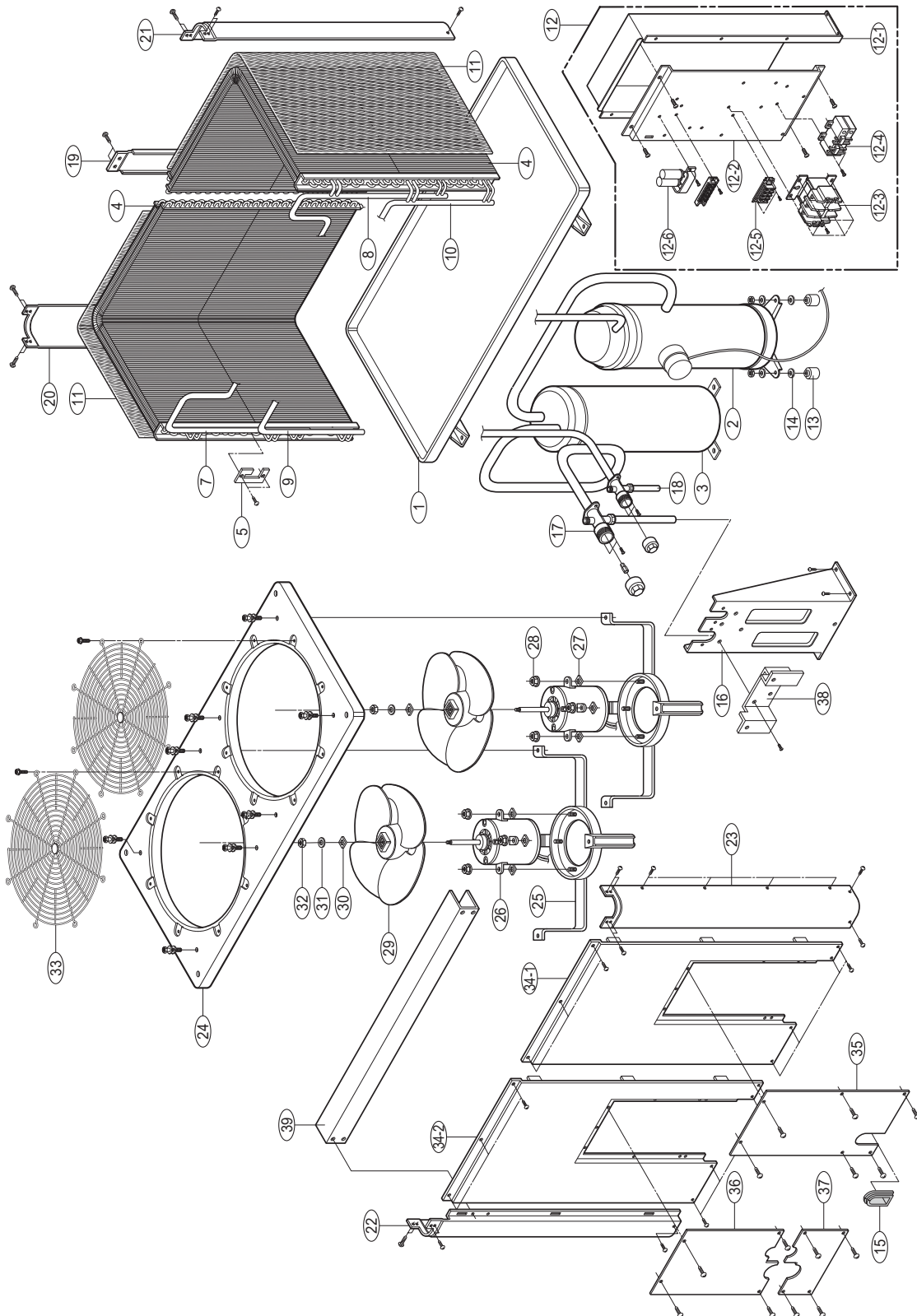

## 2) Replacement Parts List

No.	DESCRIPTION	PART NO.		Q'TY	REMARK
		LP-10091CL	LP-10091XL		
1	BASE ASSY	3041AP2606S	3041AP2606S	1	
2	COMPRESSOR	2A01180D	2A01180D	1	
3	ACCUMULATOR ASSY	3A02139S	3A02139S	1	
4	CONDENSER ASSY	5403AP2618B	5403AP2618B	4	
5	LINK SHEET	4520AP4095A	4520AP4095A	2	
6	BRACKET COND.	4810AP3697A	4810AP3697A	2	
7	MANIFOLD IN ASSY	5211AP3868A	5211AP3868A	1	
8	MANIFOLD IN ASSY	5211AP3868B	5211AP3868B	1	
9	MANIFOLD IN ASSY	5211AP3869A	5211AP3869A	1	
10	MANIFOLD IN ASSY	5211AP3869B	5211AP3869B	1	
11	MESH(COVER FIN)	2A00191Q	2A00191Q	1	
12	CONTROL BOX ASSY	4995AP2608B	4995AP2608B	1	
12-1	CASE CONTROL	3110AP2592A	3110AP2592A	1	
12-2	BOARD CONTROL	3500AP2591A	3500AP2591A	1	
12-3	MAGNETIC CONTACTOR	2A01031D	2A01031D	1	
12-4	PROTECTION RELAY	2A00999N	2A00999N	1	
12-5	TERMINAL BLOCK	3A00493A	3A00493A	1	
12-6	SH-CAPACITOR	2H00841J	2H00841J	2	
13	RUBBER MOUNTING	5040AP4241A	5040AP4241A	4	
14	RUBBER RING	5040AP4242A	5040AP4242A	4	
15	BUSHING	4830AP4182A	4830AP4182A	1	
16	SUPPORTER VALVE	4980AP2621A	4980AP2621A	1	
17	VALVE SERVICE	2A00469G	2A00469G	1	
18	VALVE SERVICE	2A00468C	2A00468C	1	
19	COVER REAR	3550AP2647P	3550AP2647P	1	
20	SUPPORTER REAR	4980AP1265Q	4980AP1265Q	1	
21	SUPPORTER REAR	4980AP1265P	4980AP1265P	1	
22	SUPPORTER FRONT	4980AP1264P	4980AP1264P	1	
23	SUPPORTER FRONT	4980AP1263P	4980AP1263P	1	
24	ORIFICE ASSY	4948AP1242P	4948AP1242P	1	



No.	DESCRIPTION	PART NO.		Q'TY	REMARK
		LP-10091CL	LP-10091XL		
25	MOUNT MOTOR ASM	3A00434A	3A00434A	2	
26	MOTOR	4860AP2610A	4860AP2610A	2	
27	BUSHING BASE COMP	4A00077A	4A00077A	8	
28	NUT	4H00947C	4H00947C	8	
29	FAN ASSY	0A00026B	0A00026B	2	
30	FAN LOCKER	4A01387A	4A01387A	2	
31	SPRING LOCK WASHER	1WSD1000030	1WSD1000030	2	
32	HEXAGON NUTS	1NHA1001206	1NHA1001206	2	
33	GRILLE COVER	2A00144P	2A00144P	2	
34-1	PANEL ASSY FRONT	3721AP2913P	3721AP2913P	1	
34-2	PANEL ASSY FRONT	3721AP2913Q	3721AP2913Q	1	
35	COVER ASSY CONTROL	3551AP7047Z	3551AP7047Z	1	
36	'PANEL INSTALL-U	3720AP3810P	3720AP3810P	1	
37	BRACKET INSTALL-L	4810AP3814P	4810AP3814P	1	
38	BRACKET F.P	4810AP7078A	4810AP7078A	1	
39	COVER FAN	3550AP3912A	3550AP3912A	1	

# 11.5 Outdoor Unit (LP-15091CL/15091XL)

## 1) Exploded View

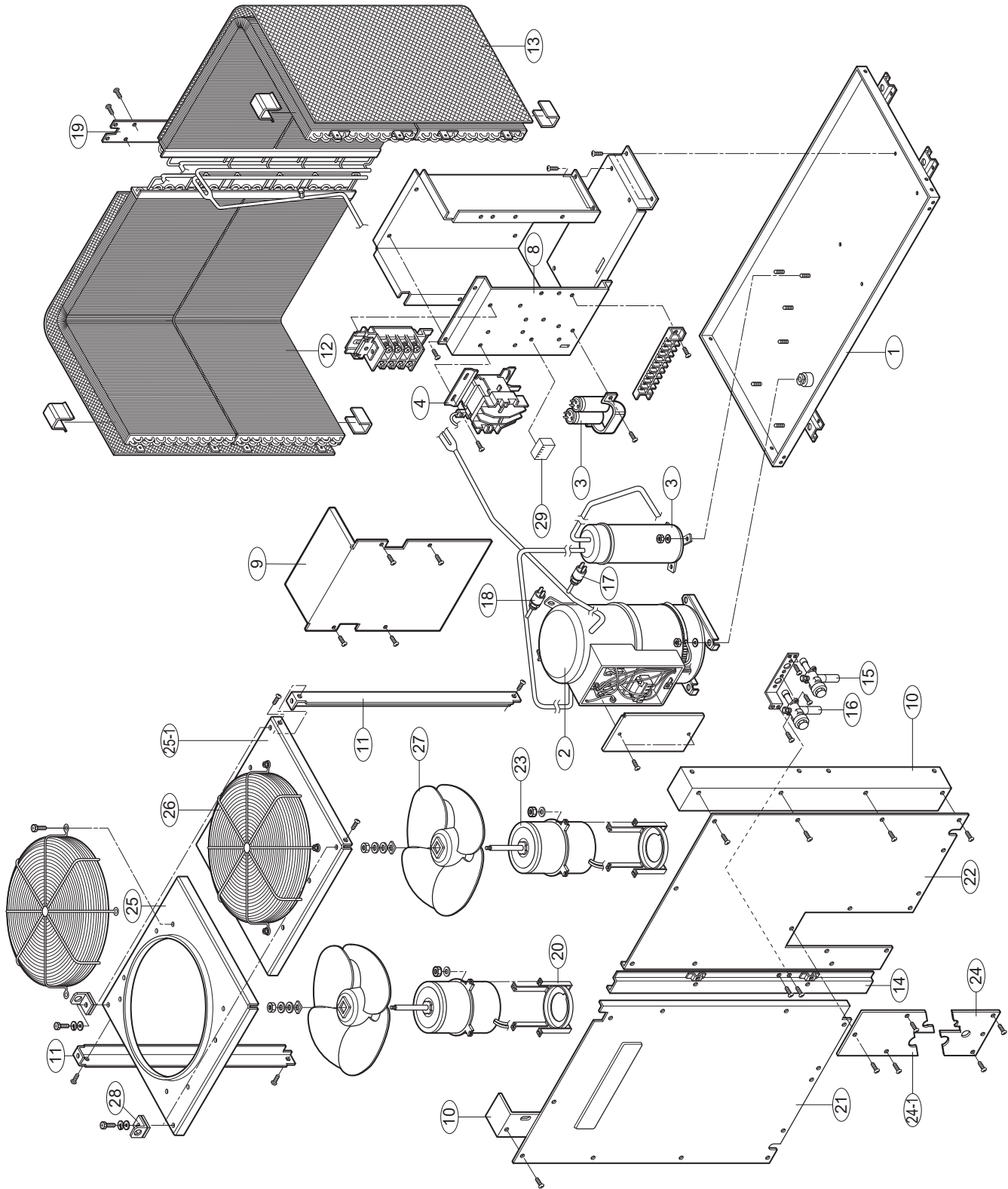

## 2) Replacement Parts List

No.	DESCRIPTION	PART NO.		Q'TY	REMARK
		LP-15091CL	LP-15091XL		
1	BSSE W. ASSY	2A01161P	2A01161P	1	
2	COMPRESSOR ASSY	2A01180C	2A01180C	1	
3	ACCUMULATOR ASSY	3A02139Q	3A02139Q	1	
4	MAGNETIC CONT.	2A01031C	2A01031C	1	
5	SH-CAPACITOR	2H00841J	2H00841J	2	
8	BKT CONTROL BASE	3A02140A	3A02140A	1	
9	COVER CONTROL	3A01701A	3A01701A	1	
10	FRONT COLUMN ASSY	3A02541P	3A02541P	1	
10-1	FRONT COLUMN ASSY	3A02541Q	3A02541Q	1	
11	REAR COLUMN ASSY	3A02367P	3A02367P	2	
12	CONDENSER ASSY	2A01158A	2A01158A	1	
12-1	CONDENSER ASSY	2A01158C	2A01158C	1	
13	CONDENSER ASSY	2A01159A	2A01159A	1	
13-1	CONDENSER ASSY	2A01159C	2A01159C	1	
14	FRONT PANEL W. ASSY	3A02389P	3A02389P	1	
15	SERVICE VALVE	2A00468B	2A00468B	1	
16	SERVICE VALVE	2A00469C	2A00469C	1	
17	HIGH PRE, S/W	6600AG3057A	6600AG3057A	1	
18	LOW PRE, S/W	3A02414B	3A02414B	1	
19	REAR PANEL	3A02355P	3A02355P	1	
20	MOUNT MOTOR	3A01717A	3A01717A	2	
21	SIDE PANEL-L	3A02350P	3A02350P	1	
22	SIDE PANEL-R	3A02350Q	3A02350Q	1	
23	MOTOR ASSY	2A00842B	2A00842B	2	
24	BRACKET INSTALL	4810AP3228Z	4810AP3228Z	1	
24-1	BRACKET INSTALL	4810AP3229Z	4810AP3229Z	1	
25	TOP COVER	2A01163P	2A01163P	1	
25-1	TOP COVER	2A01163Q	2A01163Q	1	
26	GRILLE TOP COVER	2A00823P	2A00823P	2	
27	PROPELLAR FAN	0A00026B	0A00026B	2	
28	BRACKET LIFT	4A01466P	4A01466P	4	
29	EOCR	2A00999C	2A00999M	1	

# 11.6 Outdoor Unit (LP-20091CL/20091XL)

## 1) Exploded View

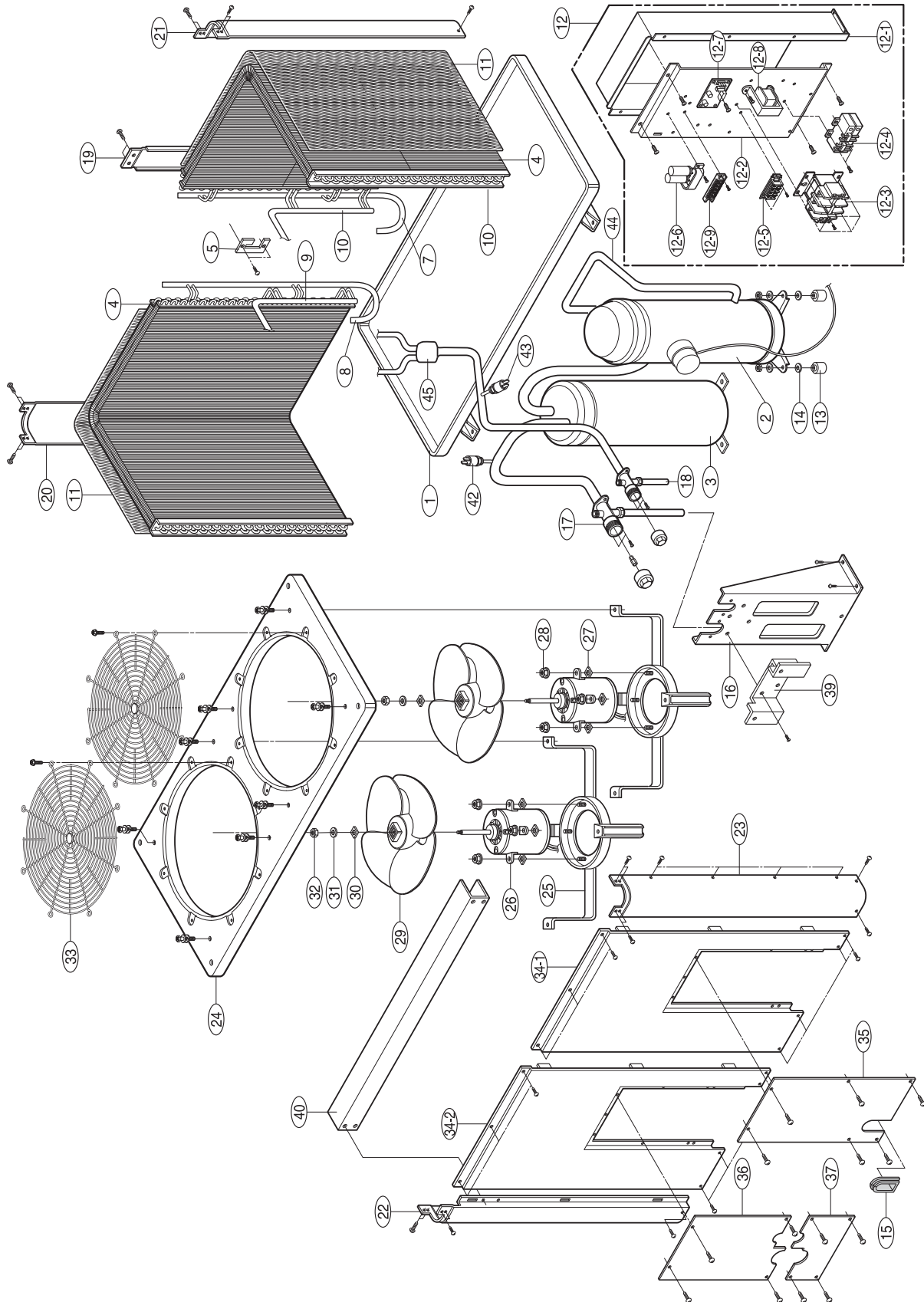

## 2) Replacement Parts List

No.	DESCRIPTION	PART NO.		Q'TY	REMARK
		LP-20091CL	LP-20091XL		
1	BASE ASSY	3041AP2606S	3041AP2606S	2	
2	COMPRESSOR	2A01180D	2A01180D	2	
3	ACCUMULATOR ASSY	3A02139S	3A02139S	2	
4	CONDENSER ASSY	5403AP2618F	5403AP2618F	8	
5	LINK SHEET	4520AP4095A	4520AP4095A	4	
6	BRACKET COND.	4810A30028A	4810A30028A	4	
7	TUBE ASSY,(MANIFOLD IN)	5211A30050C	5211A30050C	2	
8	TUBE ASSY,(MANIFOLD IN)	5211A30050D	5211A30050D	2	
9	TUBE ASSY,(MANIFOLD OUT)	5211AP3868A	5211AP3868A	2	
10	TUBE ASSY,(MANIFOLD OUT)	5211AP3868B	5211AP3868B	2	
11	MESH (COVER. FIN)	2A00191S	2A00191S	4	
12	CONTROL BOX ASSY	4995A20019C	4995A20019C	2	
12-1	CASE CONTROL	3110AP2592A	3110AP2592A	2	
12-2	BOARD CONTROL	3500AP2591A	3500AP2591A	2	
12-3	MAGNETIC CONTACTOR	2A01031C	2A01031C	2	
12-4	PROTECTION RELAY	2A00999H	2A00999N	2	
12-5	TERMINAL BLOCK	3A00493D	3A00493D	2	
12-6	SH-CAPACITOR	2H00841J	2H00841J	4	
12-7	TIMER ASSY	3Q01017A	3Q01017A	2	
12-8	TRANSFORMER	3A01073C	3A01073C	2	
12-9	TERMINAL BLOCK	3A00093A	3A00093A	2	
13	RUBBER MOUNTING	5040AP4241A	5040AP4241A	8	
14	RUBBER RING	5040AP4242A	5040AP4242A	8	
15	BUSHING	4830AP4182A	4830AP4182A	2	
16	SUPPORTER VALVE	4980AP2621A	4980AP2621A	2	
17	VALVE SERVICE	2A00469G	2A00469G	2	
18	VALVE SERVICE	2A00468E	2A00468E	2	
19	COVER TUBING	3550A20003P	3550A20003P	2	
20	SUPPORTER REAR	4980AP1265Q	4980AP1265Q	2	
21	SUPPORTER REAR	4980AP1265P	4980AP1265P	2	
22	SUPPORTER FRONT	4980AP1264P	4980AP1264P	2	
23	SUPPORTER FRONT	4980AP1263P	4980AP1263P	2	
24	ORIFICE ASSY	4948AP1242P	4948AP1242P	2	
25	MOUNT MOTOR ASSY	3A00434A	3A00434A	4	
26	MOTOR	4680AP2610A	4680AP2610A	4	

No.	DESCRIPTION	PART NO.		Q'TY	REMARK
		LP-20091CL	LP-20091XL		
27	BUSHING BASE COMP	4A00077A	4A00077A	16	
28	NUT	4H00947C	4H00947C	16	
29	FAN ASSY	0A00026B	0A00026B	4	
30	FAN LOCKER	4A01387A	4A01387A	4	
31	SPRING LOCK WASHER	1WSD1000030	1WSD1000030	4	
32	HEXAGON NUTS	1NHA1001206	1NHA1001206	4	
33	GRILLE COVER	2A00144P	2A00144P	4	
34-1	PANEL ASSY FRONT	3721AP2913P	3721AP2913P	2	
34-2	PANEL ASSY FRONT	3721AP2913Q	3721AP2913Q	2	
35	COVER ASSY CONTROL	3551AP7047Z	3551AP7047Z	2	
36	PANEL INSTALL-U	3720AP3810P	3720AP3810P	2	
37	BRACKET INSTALL-L	4810AP3814P	4810AP3814P	2	
39	BRACKET F.P	4810AP7078A	4810AP7078A	2	
40	COVER FAN	3550AP3912A	3550AP3912A	2	
42	LOW PRESSURE S/W	3A02414B	3A02414B	2	
43	HIGH PRESSURE S/W	6600AG3057A	6600AG3057A	2	
44	TUBE ASSY, DISCHARGE	5211A30051B	5211A30051B	2	
45	TUBE ASSY, CONDENSER	5211A30052A	5211A30052A	2	

