



FAN COIL DUCT TYPE

ENGINEERING INSTALLATION AND OPERATION MANUAL

RF-DT-20-02-L-M
RF-DT-30-02-L-M
RF-DT-35-02-L-M
RF-DT-45-02-L-M
RF-DT-55-02-L-M
RF-DT-70-02-L-M
RF-DT-90-02-L-M
RF-DT-110-02-L-M

CONTENTS

PAGE

TECHNICAL CHARACTERISTICS UNIT STANDARD	3
SPECIFICATION	5
COIL DATA	6
COOLING PERFORMANCE	6
HEATING PERFORMANCE	9
THERMOSTAT	13
THREE-WAY MOTORIZED VALVES	15
DIMENSIONS	17
INSTALLATION	18
MAINTENANCE	19

TECHNICAL CHARACTERISTICS UNIT STANDARD

BEARING STRUCTURE

Bearing structure made of large thickness galvanized sheet-steel with holes for fixing to wall/ceiling + Thermal-acoustic internal insulation

CABINET

Cabinet made of thick steel-sheet to make it resistant to rust, corrosion, chemical agents, solvents, aliphatic and alcohols. The cabinet is with thermo acoustic internal insulation and holes to hang unit.

AIR DELIVERY GRILL

Air delivery grill by fixed finis, adjustable on two positions (air flow can be reversed by rotating grill by 180°). Made of gray ABS (similar to RAL7035), supplied with small side doors for easy access to control planet.

HEAT EXCHANGER

Highly efficient coil which copper pipes and aluminum fins fixed by mechanical expansion. Coil connections provided with anti torsion system, hand air vent valves, hand water drain valves.

Coils tested at the pressure of 30 bar, intended to work with water at 15 bar pressure.

FAN SECTION

Fan section including 1 or 2 centrifugals fans with double air inlet metal blades (forward curved fins) directly coupled to the electric motor. Fan section statically and dynamically balanced. Extensive diameter fans (= high air flow and high static pressure) and few revolutions (= low noise level). Electric motor has 3 speeds, provided with heat protection (Xlixon), running capacitor permanently switched on, Class B, electric cables protected by double insulation. Fan section is easy to remove.

AIR FILTER

Air filter easy to remove, made of a metal frame holding filtering section which can be regenerated by water wash, blowing, suction.

DRAIN PAN

Drain pan with drain pipe Ø 21mm (standard on the same side of coil connections) and heat insulation

SWITCHBOARD

The unit is supplied equipped with connection terminal board for the ventilation speeds.

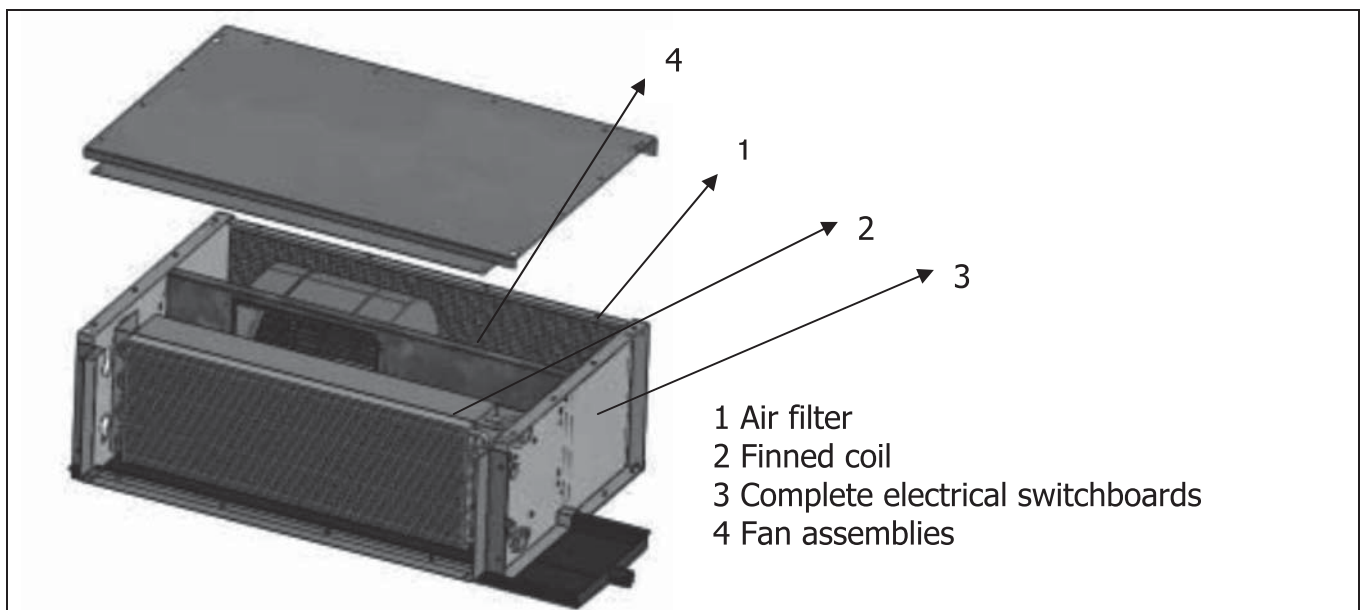

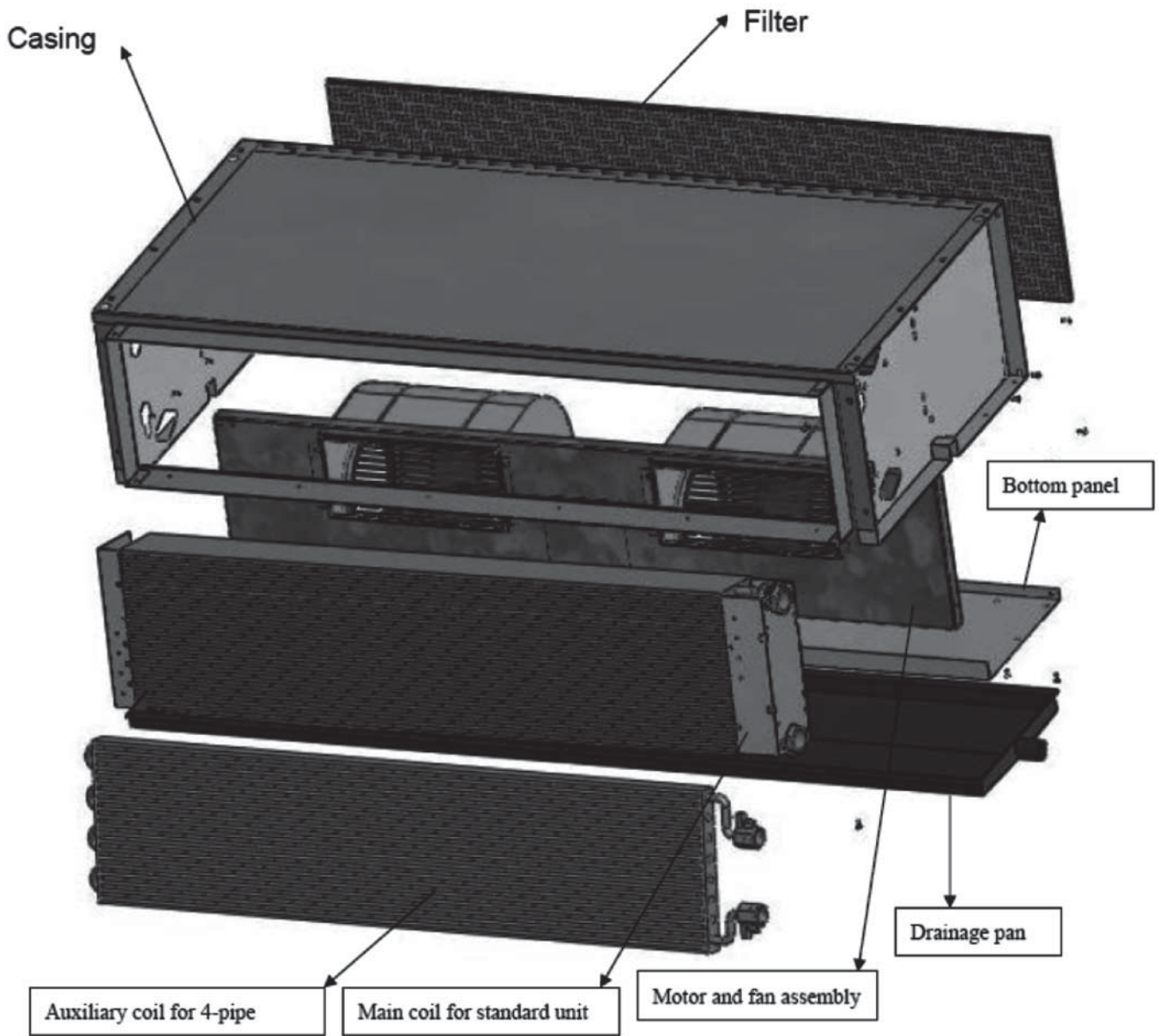

RF - DT SERIES SPECIFICATIONS:

Model			RF-DT-20-02-L-M	RF-DT-30-02-L-M	RF-DT-35-02-L-M	RF-DT-45-02-L-M	RF-DT-55-02-L-M	RF-DT-70-02-L-M	RF-DT-90-02-L-M	RF-DT-110-02-L-M	
Air Flow	H	m ³ / h	340	525	660	870	980	1300	1600	2150	
	M		260	400	560	730	875	1100	1350	1860	
	L		160	300	410	550	700	850	1090	1550	
Cooling Capacity	H	KW	1.75	2.7	3.6	4.5	5.4	7.00	9.00	11.00	
	M		1.35	2.07	3.07	4.00	4.77	6.20	7.40	9.40	
	L		0.88	1.61	2.35	3.06	4.08	5.00	5.90	8.18	
Sensible Cooling Capacity	H	KW	1.32	1.94	2.37	3.09	3.53	4.80	6.19	7.43	
	M		1.10	1.63	2.13	2.78	3.27	4.34	5.25	6.75	
	L		0.77	1.41	1.74	2.31	2.84	3.71	4.52	6.06	
Heating Capacity*	H	KW	2.15	2.98	3.90	4.74	5.45	7.63	9.20	11.38	
	M		1.76	2.43	3.46	4.03	5.04	6.81	7.85	10.30	
	L		1.21	1.96	2.75	3.38	4.29	5.64	6.73	9.10	
Power Input (ESP 12Pa)	H	W	48	55	77	85	105	156	151	250	
Power Input (ESP 30Pa)	H	W	59	76	80	101	113	154	206	274	
Power Input (ESP 50Pa)	H	W	66	76	95	113	131	182	238	277	
Power Input (ESP 70Pa)	H	W	72	83	101	130	145	230	258	280	
Noise Level(ESP 12Pa)	H	dB (A)	37	39	41	43	45	46	48	52	
Noise Level(ESP 30Pa)	H	dB (A)	40	42	44	46	47	49	50	54	
Noise Level (ESP 50Pa)	H	dB (A)	42	44	46	48	50	52	54	58	
Noise Level (ESP 70Pa)	H	dB (A)	45	47	50	53	57	60	63	70	
Water Flow	m ³ / h		0.300	0.501	0.627	0.796	0.938	1.237	1.591	1.944	
Water Pressure Drop	kPa		10.5	13	15	26	36	20.0	26	37.6	
Electrical Heater (optional)	KW		1	1.5	2	2.5	3	4	5	6	
Fan	Type	centrifugal fan (forward-curved galvanized steel fan wheel)									
	Quantity	1	2	2	2	2	4	4	4	4	
Coil	Type	seamless copper tube mechanically bonded to aluminium fin									
	Testing Pressure	2.5Mpa									
	Internal Volume	L	0.661	0.736	0.961	1.186	1.261	1.741	1.966	2.416	
Motor	Type	split-capacitor motor with ball bearing									
	Quantity	1	1	1	1	1	2	2	2	2	
	Power Supply	V / Ph / Hz	220 ~ 240V /1P/50HZ								
	Insulation Class	Class B									
	Running Current*(ESP: 12Pa)	A	0.22	0.26	0.36	0.39	0.49	0.72	0.70	1.16	
	Running Current*(ESP: 30Pa)	A	0.26	0.34	0.35	0.45	0.50	0.68	0.91	1.22	
	Running Current*(ESP: 50Pa)	A	0.29	0.34	0.42	0.50	0.58	0.81	1.06	1.23	
	Running Current*(ESP: 70Pa)	A	0.32	0.37	0.45	0.58	0.64	1.02	1.14	1.24	
Control Method	Three-Speed Switch, Thermostat or Electronic PCB										
Connection (Diameter)	Coil Conns	IN	Rc 3/4								
		OUT	Rc 3/4								
	Drain Pipe		R3/4								
	Valve (2way or 3way)		R3/4								
Working Pressure	Mpa		1.6								
Connection Method			Socket								
Net Weight	kg		15	17	22	24	26	36	38	43	
Dimensions	L	mm	720	770	920	1070	1120	1470	1620	1920	
	W		495								
	H		240								

Note:

*Cooling : 27oC db/19oC wb entering air temperature, 7oC entering water and 12oC leaving water temperature

**Heating : 20oC db entering air temperature, 50oC entering water temperature with water flow rates same as for the cooling test.

*** The air flow,cooling capacity and heating capacity are tested under ESP 12Pa and without filter.

COIL DATA (2 PIPE 3 ROW)

Model	Fin height (mm)	Fin Length (mm)	Fins per Inch	No. of Rows	Fin width (mm)	No. of Circuits	Tube ϕ (mm)
	200	441	12	3	66	2	9.52
RF-DT-30-02-L-M		491					
RF-DT-35-02-L-M		641					
RF-DT-45-02-L-M		791				3	
RF-DT-55-02-L-M		841					
RF-DT-70-02-L-M		1161					
RF-DT-90-02-L-M		1311				6	
RF-DT-110-02-L-M		1611					

COOLING PERFORMANCE (2 PIPE 3 ROWS)

RF-DT-20-02-L-M				TAI DB25°C-WB17.8°C				TAI DB27°C-WB19°C				TAI DB27°C-WB19.5°C				TAI DB29°C-WB21.1°C			
Twi	Qw	DPw	Qa	Pf	Pfs	Tad	Taw	Pf	Pfs	Tad	Taw	Pf	Pfs	Tad	Taw	Pf	Pfs	Tad	Taw
(°C)	(l/h)	(kPa)	(m ³ /h)	(kW)	(kW)	(°C)	(°C)	(kW)	(kW)	(°C)	(°C)	(kW)	(kW)	(°C)	(°C)	(kW)	(kW)	(°C)	(°C)
5	394.2	3.83	341	1.96	1.4	13	11.7	2.14	1.52	14	12.5	2.23	1.47	14.3	12.8	2.57	1.57	15.5	13.8
	318.2	2.58	267	1.56	1.18	12.1	11.5	1.7	1.30	12.9	12.2	1.8	1.23	13.5	12.6	2.05	1.31	14.6	13.6
	212.1	1.18	173	1.05	0.823	11.3	11.3	1.13	0.874	12.1	12.1	1.2	0.869	12.4	12.4	1.38	0.939	13.5	13.5
6	356.2	3.215	341	1.73	1.33	13.65	12.45	1.93	1.46	14.5	13.2	2.015	1.415	14.8	13.5	2.305	1.495	16.2	14.65
	287.25	2.19	266	1.38	1.105	12.95	12.3	1.55	1.23	13.75	13	1.625	1.19	13.9	13.3	1.835	1.23	15.4	14.45
	194.5	1.03	175	0.93	0.774	12.2	12.2	1.03	0.842	12.9	12.9	1.1	0.833	13.1	13.1	1.25	0.887	14.3	14.3
7	318.2	2.6	341	1.5	1.26	14.3	13.2	1.72	1.4	15	13.9	1.8	1.36	15.3	14.2	2.04	1.42	16.9	15.5
	256.3	1.8	265	1.2	1.03	13.8	13.1	1.4	1.16	14.6	13.8	1.45	1.15	14.3	14	1.62	1.15	16.2	15.3
	176.8	0.88	176	0.8	0.724	13	13	0.92	0.81	13.7	13.7	1.0	0.796	13.8	13.8	1.11	0.834	15.1	15.1
8	266.95	1.955	343	1.265	1.1205	15.45	13.95	1.46	1.28	16	14.7	1.51	1.26	16.15	15.1	1.745	1.35	17.45	16.35
	216.55	1.36	265.5	1.025	0.924	14.9	13.8	1.165	1.03	15.8	14.65	1.225	1.061	15.25	14.9	1.39	1.095	16.75	16.15
	152.05	0.68	174.5	0.685	0.642	14.15	13.65	0.78	0.7105	15.15	14.5	0.86	0.7395	14.6	14.6	0.955	0.775	15.95	15.95
9	215.7	1.31	345	1.03	0.981	16.6	14.7	1.2	1.16	17	15.5	1.22	1.16	17	16	1.45	1.28	18	17.2
	176.8	0.92	266	0.85	0.818	16	14.5	0.93	0.9	17	15.5	1	0.972	16.2	15.8	1.16	1.04	17.3	17
	127.3	0.48	173	0.57	0.56	15.3	14.3	0.64	0.611	16.6	15.3	0.72	0.683	15.4	15.4	0.8	0.716	16.8	16.8

Pf: total cooling capacity Tal: in flow air temperature dpw: pressure drop standard coil
 Twi: inflow fluid temperature Qw: fluid flow rate in heat exchanger Qa: air flow
 Pfs: sensible cooling capacity Tad: discharge air dry temperature Taw: discharge air wet temperature

Twi	Qw	dPw	qa	Pf	Pfs	Tad	Taw	Pf	Pfs	Tad	Taw	Pf	Pfs	Tad	Taw	Pf	Pfs	Tad	Taw
RF-DT-30-02-L-M				TAI DB25°C-WB17.8°C				TAI DB27°C-WB19°C				TAI DB27°C-WB19.5°C				TAI DB29°C-WB21.1°C			
(°C)	(l/h)	(kPa)	(m ³ /h)	(kW)	(kW)	(°C)	(°C)	(kW)	(kW)	(°C)	(°C)	(kW)	(kW)	(°C)	(°C)	(kW)	(kW)	(°C)	(°C)
5	622	10	511	3.05	1.97	13.7	11.3	3.41	2.16	14.8	12.1	3.52	2.09	15	12.4	4.02	2.21	16.3	13.4
	479	6.23	384	2.36	1.64	12.5	11.1	2.6	1.77	13.5	11.9	2.71	1.73	13.8	12.2	3.1	1.84	14.8	13.1
	327	3.05	258	1.62	1.23	11	10.9	1.82	1.35	11.8	11.6	1.85	1.29	12.3	12	2.14	1.41	13	12.9
6	554	8.25	512	2.69	1.86	14.3	12.1	3.01	2.04	15.4	12.9	3.13	1.97	15.6	13.2	3.95	2.1	16.9	14.3
	427	5.17	383	2.08	1.54	13.2	11.9	2.32	1.68	14.2	12.7	2.42	1.64	14.4	13.0	2.78	1.74	15.5	14
	296	2.6	259	1.44	1.16	11.8	11.7	1.63	1.28	12.6	12.4	1.67	1.23	13.0	12.8	1.94	1.33	13.9	13.85
7	486.	6.5	513	2.32	1.74	15	13	2.61	1.92	16	13.8	2.75	1.86	16.3	14.1	3.16	1.99	17.5	15.2
	376.	4.12	383	1.8	1.45	13.9	12.8	2.04	1.59	14.9	13.6	2.13	1.56	15	13.9	2.47	1.64	16.3	14.9
	265.	2.15	260	1.27	1.09	12.7	12.6	1.44	1.21	13.4	13.3	1.5	1.18	13.8	13.7	1.75	1.26	14.9	14.8
8	412	4.95	512	1.9	1.58	15.8	13.9	2.22	1.81	16.5	14.6	2.33	1.75	16.9	14.9	2.71	1.87	18.1	16.1
	321.	3.16	383	1.49	1.31	15	13.7	1.73	1.49	15.6	14.4	1.8	1.46	15.7	14.7	2.11	1.53	17.1	15.85
	229	1.69	262	1.07	0.97	14.2	13.5	1.22	1.09	14.6	14.2	1.3	1.10	14.6	14.5	1.52	1.18	15.7	15.65
9	339.	3.4	511	1.48	1.43	16.7	14.8	1.83	1.7	17.1	15.4	1.92	1.64	17.5	15.8	2.26	1.76	18.8	17
	267	2.2	383	1.18	1.16	16.1	14.6	1.43	1.4	16.3	15.3	1.51	1.36	16.5	15.6	1.76	1.42	18	16.8
	194.	1.23	265	0.87	0.84	15.7	14.4	1	0.98	15.8	15.1	1.1	1.03	15.5	15.4	1.3	1.11	16.6	16.5

Pf: total cooling capacity Tal: in flow air temperature dpw: pressure drop standard coil
 Twi: inflow fluid temperature Qw: fluid flow rate in heat exchanger Qa: air flow
 Pfs: sensible cooling capacity Tad: discharge air dry temperature Taw: discharge air wet temperature

RF-DT-35-02-L-M				TAI DB25°C-WB17.8°C				TAI DB27°C-WB19°C				TAI DB27°C-WB19.5°C				TAI DB29°C-WB21.1°C			
Twi [°C]	Qw [l/h]	DPw [kPa]	Qa [m3/h]	Pf [kW]	Pfs [kW]	Tad [°C]	Taw [°C]	Pf [kW]	Pfs [kW]	Tad [°C]	Taw [°C]	Pf [kW]	Pfs [kW]	Tad [°C]	Taw [°C]	Pf [kW]	Pfs [kW]	Tad [°C]	Taw [°C]
5.0	925	42	680	4.41	2.49	14.3	10.7	4.93	2.78	15	11.3	5.13	2.68	15.4	11.6	5.86	2.9	16.4	12.5
	705	30	510	3.35	2.03	13.4	10.6	3.75	2.27	14	11.2	3.91	2.27	14	11.5	4.5	2.36	15.4	12.3
	490	15.6	340	2.3	1.64	11	10.4	2.58	1.74	12.2	11	2.71	1.75	12.1	11.2	3.13	1.85	13.4	13.1
6.0	822	38	681	3.95	2.39	14.7	11.5	4.42	2.64	15.6	12.2	4.56	2.57	15.9	12.6	5.3	2.73	17.2	13.5
	635	25	511	3.06	2.01	13.5	11.3	3.41	2.18	14.5	12	3.52	2.14	14.7	12.4	4.05	2.24	16.1	13.3
	436	12.8	341	2.1	1.53	11.9	11.1	2.34	1.69	12.6	11.8	2.42	1.59	13.4	12.2	2.8	1.72	14.2	13
7.0	650	24	683	3.1	2.28	15.2	13.0	3.58	2.54	16.0	13.6	3.6	2.5	16.2	14.2	4.45	2.48	18.2	14.8
	560	18	510	2.5	1.92	14	12.6	2.87	2.08	15	13.2	3.1	2.07	15.2	13.4	3.58	2.07	17	14.3
	380	9.5	341	1.73	1.4	13	12.4	1.99	1.55	13.7	13	2.1	1.5	14.2	13.3	2.5	1.62	15.2	14.1
8.0	636	20	683	2.9	2.13	15.8	13.3	3.35	2.38	16.7	14	3.53	2.28	17.1	14.3	4.13	2.43	18.4	15.3
	496	16.2	513	2.28	1.75	15	13.1	2.6	1.94	15.8	13.8	2.75	1.9	16.1	14.1	3.2	2.0	17.4	15.1
	342	8.3	342	1.59	1.34	13.6	12.9	1.8	1.45	14.5	13.6	1.9	1.47	14.4	13.9	2.2	1.5	16	14.9
9.0	532	18	684	2.48	1.99	16.4	14	2.77	2.26	17.2	14.9	2.95	2.11	17.8	15.2	3.55	2.27	19.1	16.2
	418	11.9	513	1.9	1.67	15.4	13.9	2.23	1.86	16.3	14.6	2.32	1.79	16.7	15	2.75	1.89	18	16
	300	6.4	343	1.35	1.27	14.2	13.7	1.55	1.39	15	14.4	1.65	1.39	15.1	14.7	1.96	1.47	16.4	15.7

Pf: total cooling capacity Tal: in flow air temperature dpw: pressure drop standard coil
Twi: inflow fluid temperature Qw: fluid flow rate in heat exchanger Qa: air flow
Pfs: sensible cooling capacity Tad: discharge air dry temperature Taw: discharge air wet temperature

RF-DT-45-02-L-M				TAI DB25°C-WB17.8°C				TAI DB27°C-WB19°C				TAI DB27°C-WB19.5°C				TAI DB29°C-WB21.1°C			
Twi [°C]	Qw [l/h]	dpw [kPa]	Qa [m3/h]	Pf [kW]	Pfs [kW]	Tad [°C]	Taw [°C]	Pf [kW]	Pfs [kW]	Tad [°C]	Taw [°C]	Pf [kW]	Pfs [kW]	Tad [°C]	Taw [°C]	Pf [kW]	Pfs [kW]	Tad [°C]	Taw [°C]
5.0	1081	14.6	850	5.1	3.32	13.6	11.3	5.75	3.78	14	11.9	6.0	3.65	14.4	12.2	6.75	3.75	16	13.3
	815	8.8	623	3.9	2.76	12.3	11.1	4.31	3.0	12.9	11.7	4.52	2.99	13	12	5.18	3.14	14.4	13
	560	4.5	421	2.73	2.08	11	10.9	3.01	2.25	11.5	11.5	3.1	2.19	11.9	11.9	3.58	2.34	12.9	12.8
6.0	946	11.5	850	4.53	3.2	14	12.1	5.09	3.54	14.8	12.8	5.25	3.41	15.2	13.2	6.04	3.62	16.4	14.2
	726	7.15	632	3.46	2.64	12.8	11.9	3.89	2.91	13.5	12.6	4.03	2.78	14.1	13	4.6	2.91	15.4	14.0
	505	3.71	426	2.43	1.96	11.7	11.7	2.71	2.14	12.4	12.4	2.8	2.06	12.9	12.8	3.2	2.2	13.9	13.8
7.0	838	9.3	852	3.86	2.96	14.8	13	4.4	3.32	15.5	13.7	4.65	3.3	15.6	14	5.41	3.45	17	15
	642	5.7	630	2.97	2.41	13.8	12.8	3.38	2.68	14.5	13.5	3.56	2.66	14.6	13.8	4.13	2.82	15.8	14.8
	442	2.9	426	2.1	1.83	12.6	12.6	2.39	2.02	13.3	13.3	2.45	1.94	13.7	13.7	2.91	2.11	14.6	14.6
8.0	708	6.84	850	3.25	2.75	15.5	13.8	3.78	3.14	16.1	14.5	3.93	3.02	16.5	14.9	4.6	3.22	17.8	16
	543	4.23	625	2.52	2.28	14.4	13.6	2.92	2.57	15	14.3	3.01	2.48	15.3	14.7	3.52	2.59	16.8	15.8
	384	2.27	426	1.8	1.71	13.4	13.4	2.05	1.87	14.1	14.1	2.13	1.81	14.5	14.5	2.5	1.96	15.6	15.6
9.0	593	4.97	854	2.54	2.48	16.4	14.7	3.14	2.97	16.7	15.3	3.29	2.85	15.7	15.7	3.85	3.08	18.3	16.9
	461	3.2	632	2.0	1.95	15.9	14.5	2.45	2.42	15.7	15.1	2.56	2.33	15.5	15.5	2.96	2.44	17.5	16.7
	325	1.68	434	1.46	1.42	15.4	14.3	1.76	1.72	15.3	14.9	1.8	1.71	15.4	15.4	2.15	1.85	16.5	16.5

Pf: total cooling capacity Tal: in flow air temperature dpw: pressure drop standard coil
Twi: inflow fluid temperature Qw: fluid flow rate in heat exchanger Qa: air flow
Pfs: sensible cooling capacity Tad: discharge air dry temperature Taw: discharge air wet temperature

RF-DT-55-02-L-M				TAI DB25°C-WB17.8°C				TAI DB27°C-WB19°C				TAI DB27°C-WB19.5°C				TAI DB29°C-WB21.1°C			
Twi [°C]	Qw [l/h]	dpw [kPa]	Qa [m3/h]	Pf [kW]	Pfs [kW]	Tad [°C]	Taw [°C]	Pf [kW]	Pfs [kW]	Tad [°C]	Taw [°C]	Pf [kW]	Pfs [kW]	Tad [°C]	Taw [°C]	Pf [kW]	Pfs [kW]	Tad [°C]	Taw [°C]
5.0	1265	19.4	1020	6.02	3.84	14	11.4	6.73	4.25	14.8	12.1	7.02	4.1	15.2	12.4	8.0	4.36	16.4	13.4
	973	12.1	764	4.63	3.21	12.7	11.2	5.15	3.44	13.8	11.9	5.4	3.39	14	12.2	6.1	3.51	15.4	13.2
	670	6.1	510	3.2	2.34	11.7	11	3.55	2.52	12.6	11.7	3.71	2.52	12.6	12.0	4.2	2.58	14.2	13
6.0	1103	15.2	1021	5.25	3.66	14.5	12.3	5.92	3.96	15.6	13	6.12	3.77	16.1	13.4	7.06	4.1	17.1	14.4
	853	9.54	765	4.05	3.0	13.5	12.1	4.56	3.25	14.5	12.8	4.73	3.12	15	13.2	5.43	3.36	16	14.2
	588	4.88	511	2.85	2.26	12.1	11.8	3.06	2.32	13.5	12.7	3.26	2.31	13.8	13	3.75	2.44	15	14
7.0	988	12.4	1022	4.53	3.3	15.5	13.1	5.2	3.75	16.2	13.8	5.48	3.63	16.5	14.1	6.31	3.86	17.8	15.2
	753	7.64	765	3.52	2.81	14.2	12.9	4.01	3.11	15	13.6	4.18	3.02	15.4	14	4.86	3.23	16.5	15
	521	3.9	511	2.46	2.07	13.2	12.7	2.8	2.31	13.8	13.4	2.89	2.21	14.3	13.8	3.35	2.36	15.4	14.8
8.0	838	9.3	1028	3.89	3.22	15.7	13.8	4.44	3.56	16.7	14.6	4.65	3.44	17.1	15	5.42	3.65	18.4	16.1
	650	5.8	764	3.04	2.67	14.7	13.6	3.45	2.94	15.6	14.4	3.6	2.84	16	14.8	4.18	2.98	17.4	15.9
	452	3.1	511	2.14	2.0	13.6	13.4	2.42	2.2	14.4	14.2	2.51	2.1	14.9	14.6	2.91	2.21	16.2	15.7
9.0	676	6.3	1025	2.95	2.87	16.7	14.8	3.57	3.38	17.2	15.5	3.75	3.21	17.7	15.9	4.8	3.54	18.7	16.7
	532	4.1	765	2.35	2.3	16.1	14.6	2.81	2.76	16.3	15.3	2.95	2.64	16.8	15.7	3.75	2.89	17.8	16.5
	375	2.2	513	1.67	1.63	15.6	14.4	2.0	2.05	15.3	15.1	2.08	1.98	15.6	15.5	2.6	2.06	17	16.3

Pf: total cooling capacity Tal: in flow air temperature dpw: pressure drop standard coil
Twi: inflow fluid temperature Qw: fluid flow rate in heat exchanger Qa: air flow
Pfs: sensible cooling capacity Tad: discharge air dry temperature Taw: discharge air wet temperature

RF-DT-70-02-L-M				TAI DB25°C-WB17.8°C				TAI DB27°C-WB19°C				TAI DB27°C-WB19.5°C				TAI DB29°C-WB21.1°C			
Twi [°C]	Qw [l/h]	dpw [kPa]	Qa [m3/h]	Pf [kW]	Pfs [kW]	Tad [°C]	Taw [°C]	Pf [kW]	Pfs [kW]	Tad [°C]	Taw [°C]	Pf [kW]	Pfs [kW]	Tad [°C]	Taw [°C]	Pf [kW]	Pfs [kW]	Tad [°C]	Taw [°C]
5.0	1729	37.3	1361	8.25	4.93	14.4	11.2	9.17	5.37	15.4	11.9	9.59	5.27	15.6	12.2	11	5.57	16.9	13.1
	1334	23.4	1023	6.36	4.05	13.4	11.0	7.1	4.41	14.4	11.7	7.4	4.36	14.5	12	8.45	4.57	15.8	12.9
	912	11.8	682	4.37	3.07	11.9	10.8	4.85	3.27	13	11.5	5.06	3.22	13.2	11.8	5.8	3.45	14.2	12.7
6.0	1512	29.3	1361	7.22	4.64	15	12.1	8.12	5.03	16.1	12.8	8.39	4.93	16.3	13.2	9.78	5.24	17.6	14.1
	1172	18.5	1022	5.6	3.84	14	11.9	6.28	4.17	15	12.6	6.5	4.1	15.2	13	7.45	4.32	16.5	14
	815	9.6	681	3.85	2.85	12.8	11.7	4.32	3.15	13.5	12.4	4.52	3.12	13.6	12.7	5.25	3.3	14.8	13.6
7.0	1314	22.8	1362	6.28	4.35	15.6	12.9	7.04	4.75	16.7	13.7	7.29	4.69	16.8	14.1	8.52	4.95	18.2	15.1
	1024	14.5	1024	4.9	3.63	14.6	12.7	5.46	3.91	15.7	13.5	5.68	3.82	16	13.9	6.58	4.06	17.2	14.9
	717	7.6	682	3.4	2.7	13.4	12.5	3.84	2.98	14.2	13.2	3.98	2.88	14.6	13.6	4.68	3.11	15.6	14.5
8.0	1132	17.4	1361	5.31	4.16	16	13.7	6.05	4.52	17.2	14.5	6.28	4.36	17.5	14.9	7.33	4.62	18.9	16
	885	11.2	1022	4.16	3.4	15.2	13.5	4.72	3.74	16.2	14.3	4.91	3.63	16.5	14.7	5.7	3.78	18	15.8
	616	5.8	684	2.91	2.56	14	13.3	3.3	2.8	15	14.1	3.42	2.74	15.2	14.5	4.01	2.88	16.5	15.5
9.0	944	12.6	1361	4.32	3.83	16.7	14.5	5.02	4.32	17.6	15.3	5.24	4.12	18	15.7	6.12	4.38	19.4	16.9
	746	8.2	1023	3.43	3.23	15.7	14.3	3.96	3.56	16.7	15.1	4.14	3.42	17.1	15.5	4.9	3.64	18.4	16.6
	521	4.3	681	2.42	2.35	14.9	14.1	2.78	2.64	15.6	14.9	2.89	2.56	15.9	15.3	3.48	2.79	16.9	16.3

Pf: total cooling capacity Tal: in flow air temperature dpw: pressure drop standard coil
Twi: inflow fluid temperature Qw: fluid flow rate in heat exchanger Qa: air flow
Pfs: sensible cooling capacity Tad: discharge air dry temperature Taw: discharge air wet temperature

RF-DT-90-02-L-M				TAI DB25°C-WB17.8°C				TAI DB27°C-WB19°C				TAI DB27°C-WB19.5°C				TAI DB29°C-WB21.1°C			
Twi [°C]	Qw [l/h]	dpw [kPa]	Qa [m3/h]	Pf [kW]	Pfs [kW]	Tad [°C]	Taw [°C]	Pf [kW]	Pfs [kW]	Tad [°C]	Taw [°C]	Pf [kW]	Pfs [kW]	Tad [°C]	Taw [°C]	Pf [kW]	Pfs [kW]	Tad [°C]	Taw [°C]
5.0	2105	34.2	1700	10.18	6.16	14.4	11.3	11.32	6.65	15.5	12	11.68	6.41	15.9	12.4	13.3	6.67	17.4	13.4
	1622	21.4	1276	7.82	5.05	13.4	11.1	8.72	5.52	14.3	11.8	9.0	5.26	14.9	12.2	10.3	5.61	16	13.1
	1110	10.8	850	5.4	3.87	11.8	10.9	6.0	4.16	12.8	11.6	6.16	3.93	13.5	12	7.1	4.28	14.3	12.9
6.0	1865	27.5	1703	8.89	5.8	15	12.2	10.0	6.35	16	12.9	10.35	6.05	16.5	13.3	11.9	6.36	17.9	14.3
	1442	17.3	1276	6.86	4.82	13.9	12	7.73	5.21	15	12.7	8.0	4.99	15.5	13.1	9.16	5.25	16.8	14.1
	991	8.82	851	4.75	3.6	12.7	11.8	5.32	3.9	13.6	12.5	5.5	3.75	14.1	12.9	6.4	4.04	15.1	13.8
7.0	1644	21.9	1703	7.7	5.44	15.6	13	8.8	6.0	16.6	13.7	9.12	5.75	17	14.1	10.65	6.19	18.2	15.1
	1272	13.8	1273	5.99	4.51	14.6	12.8	6.8	4.96	15.5	13.5	7.06	4.75	16	13.9	8.2	5.06	17.2	14.9
	883	7.2	854	4.16	3.41	13.3	12.6	4.72	3.78	14	13.3	4.9	3.57	14.7	13.7	5.68	3.82	15.8	14.7
8.0	1388	16.2	1703	6.48	5.13	16.1	13.8	7.4	5.7	17.1	14.6	7.7	5.46	17.5	15	9.16	5.83	18.8	16
	1083	10.3	1275	5.08	4.24	15.2	13.6	5.77	4.7	16.1	14.4	6.01	4.48	16.6	14.8	7.11	4.8	17.8	15.8
	757	5.43	856	3.56	3.23	13.9	13.4	4.02	3.47	15	14.2	4.2	3.43	15.2	14.6	4.94	3.64	16.4	15.6
9.0	1153	11.6	1705	5.24	4.9	16.5	14.6	6.1	5.27	17.8	15.4	6.4	5.1	18.1	15.8	7.63	5.47	19.4	16.9
	908	7.53	1276	4.15	4.06	15.6	14.4	4.81	4.39	16.8	15.2	5.04	4.22	17.2	15.6	5.98	4.54	18.4	16.7
	638	3.99	854	2.95	2.88	15.1	14.2	3.4	3.31	15.6	15	3.54	3.15	16.1	15.4	4.18	3.4	17.2	16.5

Pf: total cooling capacity Tal: in flow air temperature dpw: pressure drop standard coil
Twi: inflow fluid temperature Qw: fluid flow rate in heat exchanger Qa: air flow
Pfs: sensible cooling capacity Tad: discharge air dry temperature Taw: discharge air wet temperature

RF-DT-90-02-L-M				TAI DB25°C-WB17.8°C				TAI DB27°C-WB19°C				TAI DB27°C-WB19.5°C				TAI DB29°C-WB21.1°C			
Twi [°C]	Qw [l/h]	dpw [kPa]	Qa [m3/h]	Pf [kW]	Pfs [kW]	Tad [°C]	Taw [°C]	Pf [kW]	Pfs [kW]	Tad [°C]	Taw [°C]	Pf [kW]	Pfs [kW]	Tad [°C]	Taw [°C]	Pf [kW]	Pfs [kW]	Tad [°C]	Taw [°C]
5.0	2938	52.8	2347	14.2	8	15	11.2	15.6	8.76	16	12	16.3	8.43	16.4	12.3	18.9	8.86	17.9	13.2
	2253	32.8	1751	11.1	6.64	14.1	11	12.2	7.3	15	11.8	12.5	7.1	15.1	12.1	14.5	7.5	16.5	13
	1586	17.5	1186	7.65	5.1	12.4	10.7	8.5	5.59	13.2	11.4	8.8	5.48	13.5	11.8	10.2	5.81	14.7	12.6
6.0	2613	42.6	2354	12.5	7.54	15.6	12.1	14	8.2	16.7	12.8	14.5	7.96	17	13.2	17	8.45	18.4	14.1
	2036	27.3	1780	9.8	6.29	14.7	11.9	11	6.94	15.6	12.6	11.3	6.7	15.9	13	13.1	7.08	17.2	13.9
	1415	14.1	1183	6.8	4.79	13.2	11.6	7.6	5.26	14	12.3	7.85	5.13	14.3	12.7	9.1	5.48	15.4	13.6
7.0	2270	33.2	2355	10.7	7.15	16.1	13	12.2	7.83	17.2	13.7	12.6	7.54	17.5	14.1	14.9	7.97	18.9	15
	1784	21.3	1787	8.4	5.96	15.2	12.8	9.5	6.56	16.1	13.5	9.9	6.29	16.6	13.9	11.7	6.76	17.8	14.8
	1243	11.2	1184	5.87	4.52	13.8	12.5	6.7	4.95	14.8	13.2	6.9	4.83	15	13.6	8.1	5.14	16.2	14.5
8.0	1919	24.5	2358	9	6.72	16.6	13.8	10.25	7.41	17.7	14.6	10.65	7.14	18	15	12.7	7.51	19.5	16
	1550	16.8	1970	7.3	5.59	15.8	13.5	8.25	6.16	16.8	14.3	8.6	6	17.1	14.7	10.2	6.34	18.5	15.7
	1069	8.6	1186	5.1	4.24	14.6	13.3	5.78	4.64	15.4	14	5.93	4.55	15.7	14.5	7	4.86	16.9	15.5
9.0	1593	17.5	2355	7.4	6.31	17	14.5	8.5	7.02	18.2	15.4	8.84	6.72	18.5	15.8	10.6	7.19	19.9	16.9
	1271	11.6	1786	5.8	5.24	16.3	14.4	6.75	5.79	17.4	15.2	7.05	5.59	17.7	15.6	8.4	5.94	18.9	16.6
	901	6.3	1180	4.1	4	15.1	14.2	4.7	4.41	16	15	5	4.23	16.4	15.3	5.9	4.57	17.5	16.4

Pf: total cooling capacity Tal: in flow air temperature dpw: pressure drop standard coil
Twi: inflow fluid temperature Qw: fluid flow rate in heat exchanger Qa: air flow
Pfs: sensible cooling capacity Tad: discharge air dry temperature Taw: discharge air wet temperature

HEATING PERFORMANCE (2 PIPE 3 ROWS)

RF-DT-20-02-L-M				TAI 18°C		TAI 20°C		TAI 22°C		TAI 24°C	
Twi [°C]	Qw [l/h]	DPw [kPa]	Qa [m ³ /h]	Pf [kW]	Tad [°C]	Pf [kW]	Tad [°C]	Pf [kW]	Tad [°C]	Pf [kW]	Tad [°C]
40	88.3	0.224	341	1.13	28.2	1.03	29.3	0.93	30.4	0.83	31.5
	72.8	0.16	267	0.94	29.1	0.85	30	0.78	31	0.69	32
	54.8	0.096	173	0.7	30.5	0.64	31.4	0.57	32.3	0.51	33.2
50	167.2	0.72	348	2.05	36.5	1.95	37.3	1.81	38.2	1.68	39.1
	137	0.5	267	1.71	38.1	1.6	38.5	1.5	39.5	1.39	40.3
	102	0.3	177	1.26	40.5	1.19	40.7	1.1	41.7	1.02	42.3
60	244.3	1.41	343	3	45	2.85	45.7	2.71	46.5	2.56	47.1
	202.3	1.0	265	2.48	46.9	2.36	47.5	2.24	48.3	2.12	49
	146.6	0.56	173	1.8	50.2	1.71	50.5	1.63	51.1	1.54	51.9
70	320	2.3	343	3.92	53.3	3.73	53.6	3.62	54.6	3.47	55.2
	266.6	1.64	265	3.23	56	3.11	56.2	2.98	57.1	2.86	57.7
	192	0.9	173	2.35	59.9	2.24	60	2.17	61	2.08	61.5

Pf: total heating capacity Tai: in flow air temperature
 dpw: pressure drop standard coil Twi: in flow fluid temperature
 Qw: fluid flow rate in heat exchanger Qa: air flow
 Tad: discharge air temperature

RF-DT-30-02-L-M				TAI 18°C		TAI 20°C		TAI 22°C		TAI 24°C	
Twi [°C]	Qw [l/h]	DPw [kPa]	Qa [m ³ /h]	Pf [kW]	Tad [°C]	Pf [kW]	Tad [°C]	Pf [kW]	Tad [°C]	Pf [kW]	Tad [°C]
40	125	0.47	511	1.61	27.7	1.46	28.8	1.31	29.9	1.16	31
	103.7	0.342	384	1.32	28.6	1.21	29.7	1.09	30.8	0.97	31.8
	78	0.21	258	1	29.9	0.91	31	0.82	31.8	0.73	32.8
50	232	1.46	511	2.88	35.4	2.71	36.4	2.53	37.3	2.35	38.2
	189.4	1.0	385	2.36	37	2.21	37.7	2.07	38.6	1.92	39.5
	141.4	0.6	255	1.77	39.3	1.65	40	1.55	40.7	1.45	41.4
60	341	2.93	512	4.16	43.2	3.98	44	3.75	44.7	3.56	45.5
	280	2.04	387	3.43	45.4	3.26	46	3.1	47	2.93	47.6
	209	1.22	258	2.56	48.6	2.44	49.3	2.32	50	2.2	50.5
70	452	4.86	511	5.45	51	5.27	51.6	5.05	52.5	4.8	53
	364.3	3.25	384	4.46	53.6	4.25	54.2	4.1	54.8	3.92	55.5
	274.3	1.97	258	3.35	57.8	3.2	58.3	3.06	59	2.94	59.5

Pf: total heating capacity Tai: in flow air temperature
 dpw: pressure drop standard coil Twi: in flow fluid temperature
 Qw: fluid flow rate in heat exchanger Qa: air flow
 Tad: discharge air temperature

RF-DT-35-02-L-M				TAI 18°C		TAI 20°C		TAI 22°C		TAI 24°C	
Tw _i [°C]	Q _w [1/h]	DP _w [kPa]	Q _a [m ³ /h]	P _f [kW]	T _{ad} [°C]	P _f [kW]	T _{ad} [°C]	P _f [kW]	T _{ad} [°C]	P _f [kW]	T _{ad} [°C]
40	200	2.7	686	2.54	29.5	2.33	30.5	2.08	31.4	1.84	32.3
	163	1.88	511	2.07	30.5	1.9	31.5	1.7	32.3	1.51	33.1
	121	1.1	340	1.55	32	1.41	32.8	1.26	33.4	1.13	34.2
50	351	7.51	681	4.35	37.7	4.1	38.6	3.84	39.3	3.55	40.1
	288	5.25	512	3.59	39.7	3.36	40.3	3.14	41	2.91	41.6
	214	3.08	346	2.64	41.8	2.5	42.3	2.33	43	2.16	43.5
60	510	14.6	681	6.2	46	5.95	47	5.64	47.5	5.3	48
	412	9.97	512	5.04	48.5	4	49	4.56	49.5	4.34	50.2
	300	5.65	343	3.69	51.3	3.5	51.5	3.38	52.5	3.23	53.2
70	667	23.8	687	8.0	54	7.78	55	7.44	55.6	7.1	56.2
	538	16.1	510	6.52	57.5	6.28	58	6.02	58.4	5.78	58.9
	396	9.4	342	4.86	61.6	4.62	61.8	4.45	62.2	4.3	62.7

Pf: total heating capacity
 dpw: pressure drop standard coil
 Qw: fluid flow rate in heat exchanger
 Tad: discharge air temperature
 Tai: in flow air temperature
 Twi: in flow fluid temperature
 Qa: air flow

RF-DT-45-02-L-M				TAI 18°C		TAI 20°C		TAI 22°C		TAI 24°C	
Tw _i [°C]	Q _w [1/h]	DP _w [kPa]	Q _a [m ³ /h]	P _f [kW]	T _{ad} [°C]	P _f [kW]	T _{ad} [°C]	P _f [kW]	T _{ad} [°C]	P _f [kW]	T _{ad} [°C]
40	237	0.8	853	3.03	29	2.76	30	2.48	31	2.21	32
	191	0.6	632	2.44	29.9	2.23	30.9	2.0	31.8	1.78	32.7
	142	0.3	425	1.82	31.2	1.65	32	1.49	32.8	1.32	33.6
50	429	2.4	854	5.33	37.3	5.0	38.1	4.69	39	4.36	39.8
	346	1.6	634	4.29	39	4.04	39.7	3.78	40.4	3.51	41.2
	257	0.9	428	3.18	41	2.99	41.6	2.8	42.2	2.6	42.9
60	626	4.7	851	7.66	45.8	7.3	46.5	6.97	47.2	6.6	47.9
	502	3.2	631	6.14	48.1	5.86	48.7	5.6	49.4	5.31	50
	371	1.9	423	4.55	50.9	4.33	51.6	4.15	52	3.92	52.4
70	820	7.6	851	10	54.2	9.56	54.7	9.16	55.3	8.86	56
	664	5.2	633	8	57.2	7.74	57.8	7.41	58.4	7.15	58.9
	487	3.0	425	5.91	61	5.68	61.3	5.48	61.9	5.26	62.4

Pf: total heating capacity
 dpw: pressure drop standard coil
 Qw: fluid flow rate in heat exchanger
 Tad: discharge air temperature
 Tai: in flow air temperature
 Twi: in flow fluid temperature
 Qa: air flow

RF-DT-55-02-L-M				TAI 18°C		TAI 20°C		TAI 22°C		TAI 24°C	
Twi [°C]	Qw [l/h]	DPw [kPa]	Qa [m3/h]	Pf [kW]	Tad [°C]	Pf [kW]	Tad [°C]	Pf [kW]	Tad [°C]	Pf [kW]	Tad [°C]
40	267	1.1	1022	3.4	28.3	3.11	29.4	2.81	30.5	2.48	31.5
	219	0.7	765	2.8	29.3	2.55	30.3	2.3	31.3	2.05	32.3
	163	0.4	511	2.08	30.6	1.9	31.5	1.71	32.3	1.52	33.2
50	487	3.0	1021	6.05	36.3	5.68	37.2	5.3	38	4.96	39
	399	2.1	765	4.95	38	4.65	38.8	4.34	39.5	4.04	40.3
	295	1.2	511	3.65	40.1	3.44	40.8	3.22	41.5	2.98	42
60	712	6.0	1022	8.7	44.3	8.3	45.1	7.94	46	7.51	46.7
	583	4.2	767	7.15	46.8	6.8	47.4	6.47	48.2	6.12	48.7
	429	2.4	429	5.26	49.6	5.0	50.2	4.76	50.8	4.51	51.3
70	937	9.7	1023	11.37	52.4	10.93	53	10.5	53.7	10.02	54.3
	763	6.7	764	9.27	55.4	8.9	56	8.6	56.7	8.2	57.3
	560	3.8	510	6.82	59	6.52	59.5	6.35	60.2	6.05	60.6

Pf: total heating capacity Tai: in flow air temperature
 dpw: pressure drop standard coil Twi: in flow fluid temperature
 Qw: fluid flow rate in heat exchanger Qa: air flow
 Tad: discharge air temperature

RF-DT-70-02-L-M				TAI 18°C		TAI 20°C		TAI 22°C		TAI 24°C	
Twi [°C]	Qw [l/h]	DPw [kPa]	Qa [m3/h]	Pf [kW]	Tad [°C]	Pf [kW]	Tad [°C]	Pf [kW]	Tad [°C]	Pf [kW]	Tad [°C]
40	363	1.93	1362	4.64	28.5	4.23	29.6	3.79	30.6	3.39	31.7
	295	1.33	1022	3.77	29.4	3.44	30.4	3.11	31.4	2.76	32.3
	220	0.8	682	2.82	30.8	2.56	31.6	2.31	32.4	2.05	33.3
50	658	5.63	1362	8.15	36.5	7.67	37.4	7.15	38.2	6.65	39.1
	531	3.83	1023	6.63	38	6.19	38.7	5.78	39.5	5.4	40.3
	395	2.24	683	4.93	40.3	4.6	40.8	4.31	41.5	4.01	42.1
60	952	10.96	1361	11.65	44.4	11.1	45.2	10.56	45.9	9.96	46.6
	774	7.6	1022	9.51	46.8	9.03	47.3	8.58	47.9	8.12	48.6
	575	4.4	681	7.05	49.9	6.7	50.4	6.35	50.7	6.03	51.4
70	1244	17.8	1363	15.1	52.2	14.51	52.9	13.93	53.6	13.42	54.4
	1020	12.4	1024	12.35	55.2	11.9	55.9	11.43	56.5	10.96	57
	746	7.1	681	9.04	59	8.7	60.6	8.06	60.6		

Pf: total heating capacity Tai: in flow air temperature
 dpw: pressure drop standard coil Twi: in flow fluid temperature
 Qw: fluid flow rate in heat exchanger Qa: air flow
 Tad: discharge air temperature

RF-DT-90-02-L-M				TAI 18°C		TAI 20°C		TAI 22°C		TAI 24°C	
Twi [°C]	Qw [1/h]	DPw [kPa]	Qa [m3/h]	Pf [kW]	Tad [°C]	Pf [kW]	Tad [°C]	Pf [kW]	Tad [°C]	Pf [kW]	Tad [°C]
40	430	1.68	1701	5.51	28	5.01	29.1	4.48	30.1	3.98	31.2
	351	1.2	1277	4.5	28.9	4.09	29.9	3.68	30.9	3.26	31.9
	263	0.7	852	3.36	30.2	3.06	31.1	2.76	32	2.45	32.9
50	780	4.93	1704	9.75	35.7	9.1	36.5	8.5	37.4	7.9	38.3
	638	3.43	1277	7.9	37.1	7.44	38	6.94	38.8	6.45	39.6
	475	2.0	852	5.9	39.4	5.54	40.1	5.19	40.8	4.8	41.4
60	1145	9.82	1705	14	43.4	13.35	44.2	12.7	45	11.95	45.7
	926	6.71	1275	11.32	45.4	10.8	46.2	10.3	47	9.8	47.7
	687	3.9	854	8.45	48.6	8.01	49	7.65	49.8	7.25	50.3
70	1500	16	1706	18.21	51.1	17.57	51.8	16.02	53.1		
	1226	11.1	1277	14.81	54	14.3	54.6	13.7	55.2	13.1	55.7
	903	6.4	852	11	57.7	10.53	58.2	10.2	58.8	9.71	59.2



Pf: total heating capacity Tai: in flow air temperature
 dpw: pressure drop standard coil Twi: in flow fluid temperature
 Qw: fluid flow rate in heat exchanger Qa: air flow
 Tad: discharge air temperature

RF-DT-110-02-L-M				TAI 18°C		TAI 20°C		TAI 22°C		TAI 24°C	
Twi [°C]	Qw [1/h]	DPw [kPa]	Qa [m3/h]	Pf [kW]	Tad [°C]	Pf [kW]	Tad [°C]	Pf [kW]	Tad [°C]	Pf [kW]	Tad [°C]
40	581	2.47	2381	7.42	27.6	6.78	28.8	6.1	29.9	5.4	31
	476	1.72	1786	6.14	28.7	5.55	29.6	5	30.6	4.44	31.7
	358	1.04	1196	4.58	29.8	4.18	30.8	3.75	31.7	3.32	32.7
50	1020	6.75	2373	13	34.9	11.95	35.33	10.58	36.7	9.37	37.7
	857	4.94	1786	10.75	36.5	10	37.3	9.37	38.2	8.69	39.1
	643	2.96	1200	7.94	38.6	7.5	39.3	7	40.1	6.5	40.8
60	1534	14.2	2384	18.75	42.3	17.43	43.2	16.1	44	14.9	44.9
	1252	9.82	1790	15.3	44.3	14.6	45.2	13.87	46	13.1	46.7
	926	5.68	1192	11.3	47.4	10.8	48	10.3	48.8	9.78	49.2
70	2014	23.1	2388	24.45	49.6	23.5	50.4	22.5	51.2	21.6	52
	1629	15.6	1790	19.8	52	19	52.8	18.4	53.6	17.6	54.3
	1221	9.4	1196	14.8	56.1	14.25	56.8	13.6	57.6	13	58

Pf: total heating capacity Tai: in flow air temperature
 dpw: pressure drop standard coil Twi: in flow fluid temperature
 Qw: fluid flow rate in heat exchanger Qa: air flow
 Tad: discharge air temperature

THERMOSTAT

HR2008 Series thermostats are available for individual room temperature control in residential, industrial and business premises. Suitable for 2-pipe or 4-pipe Fan Coil configuration.

HR2008 adopts digital control technology with large LCD display, It shows the following items: working states (cool, heat or ventilation), the speed of fan coil, room temperature, set-point. There are following keys on the panel: On/Off “”, Exchange mode (cool, heat or ventilation) “M”, timer “”, Select fan speed (high, medium, low or auto) “”, set-point temperature “▲” and “▼”.



MODEL DENOMINATIONS







HR2008 -

T: Clock and timing on/off. Blank is invalid.
R: IR remote function. Blank is invalid. (*remote controller should be ordered additionally*)
L: Backlight available. Blank is invalid.













E: Auto Recovery. Blank is invalid.

Y: Control damper to open or close.
DA/DA2: Control Motorized Valve (DA: Control 2-wire N.C. FCU valve; DA2: Control 3-wire FCU valve) and 3-speed fan; When the temperature reaches the set-point, it will close the Motorized Valve with the fan still running.
DB/DB2: Control Motorized Valve (DB: Control 2-wire N.C. FCU valve; DB2: Control 3-wire FCU valve) and 3-speed fan; When the temperature reaches the set-point, it will close the Motorized Valve and Fan both.
FCV2: Control 4 pipe fan coil units, Control two Motorized Valves and 3-speed fan, when the temperature reaches the set-point, it will close the Motorized Valves with the fan still running.















BASIC FEATURES

-  Room temperature setting
-  Manual or Auto 3-speed changeover
-  Defrost (low temperature protection)
-  Auto Recovery (E, Option)
-  Clock and Timer (-T, Option)
-  IR remote control (-R, Option)
-  Blue Backlight (-L, Option)











STATUS DISPLAY

-  Working Status: Cool  , Heat  , Ventilation 
-  Fan Speeds: Low  , Medium  , High  and Auto 
-  Room temperature display
-  Temperature setting
-  Clock week display (-T, Option)

SPECIFICATIONS

-  Sensing element: NTC
-  Accuracy : ±1°C
-  Set-point range: 5°C to 35°C
-  Display range: 0~50°C
-  Operating Temperature: 0~45°C
-  Operating Humidity: 5~90%RH (non-condensing)
-  Power supply: AC 85~260V, 50/60Hz
-  Switch current rating: Resistive: 2 A; Inductive: 1 A
-  Rated Power: < 1 W
-  Wirings: Screw-in terminals, each terminal capable of accepting 2 x 1.5 mm² or 1 x 2.5 mm² wires
-  Housing: ABS+PC Flame Retardant
-  Dimensions: 86 × 86 × 13 mm (W × H × D)
-  Hole pitch: 60mm (Standard)
-  Protection Class: IP30
-  Display: LCD

OPERATION

- ⇨ On/Off: Press “” to turn on, press “” again to turn off thermostat and its output.
- ⇨ Setting temperature: Press “▼” to reduce set-point, press “▲” to raise set-point.
- ⇨ Mode Selection: Press “M” to change system working in cooling “”, heating “” or ventilation “” mode, the related icon will flash, and it will be confirmed automatically after 5 seconds. The ventilation function is invalid for HR2008Y(E).
- ⇨ Fan Speed Selection (HR2008DA[E]/DB[E]/DA2[E]/DB2[E]/FCV2[E]): Press “” to change fan speed among “ (Hi)”, “ (Med)”, “ (Low)” or “ (Auto)”.
- Under auto fan speed “”, the fan-speed will be changed automatically. Auto LOW-speed When the difference between room-temperature and set-point exceed 1°C, Auto MED-speed When exceed 2°C, Auto HI-speed When exceed 3°C.
- ⇨ Control Damper (HR2008Y[E]): The damper will be open when the room temperature is higher than set-point in cooling, or room temperature is lower than set-point in heating, Otherwise the damper will be closed.
- ⇨ Control Motorized Valve under 2-pipe configuration (HR2008DA[E]/DB[E]/DA2[E]/DB2[E]): If the difference between room temperature and set-point exceed 1°C, FCU valve will be open; if room temperature and set-point are equal, HR2008DA[E]/DA2[E] will close the FCU valve with the fan still running, HR2008DB[E]/DB2[E] will close the FCU valve and Fan both.
- ⇨ Control FCU Valve under 4-pipe configuration (HR2008FCV2[E]): In cooling, when the room temperature is higher than set-point, the cooling valved will be opened. Otherwise it will be closed. Heating valve is always closed. In heating, When the room temperature is lower than set-point, the heating valve will be opened. Otherwise it will be closed. Cooling valve is always closed.

AUTO RECOVERY (Option)

☞ When the thermostat is at ON status for one minute, if power cut, it will return back to running automatically with the status how it is one minute ago after power coming back.

☞ When the thermostat is at OFF status for one minute, if power cut, it will keep OFF status after power coming back.

FUNCTIONS ASSOCIATED WITH TIMER ARE IN THE FOLLOWING (Option)

☞ Clock calibration: Press “⊕” till to display “hh:mm” and “mm” flash, press “▲” or “▼” to adjust minute, press “⊕”, “hh” flash, press “▲” or “▼” to adjust hour; Press “⊕”, “week” flash, press “▲” or “▼” to adjust Mon to Sun.

☞ Sleep function setting: Press “⊕”, till to display “☾” and flash, press “▲” to confirm, press “▼” to cancel.

☞ Timer on /Timer off: Press “⊕” till to display “⊕” and “TIMER ON” and all flash, and also “mm” flash, press “▲” or “▼” to adjust minute, press “⊕”, “hh” flash, press “▲” or “▼” to adjust hour; Press “⊕” till to display “⊕” and “TIMER OFF” and all flash, and also “mm” flash, press “▲” or “▼” to adjust minute, press “⊕”, “hh” flash, press “▲” or “▼” to adjust hour.

☞ Canceling timer on / Canceling timer off: Press “⊕” till to display “⊕” and “TIMER ON” and all flash, and also “mm” flash, press “▲” or “▼” to adjust minute to “00”. press “⊕”, “hh” flash, press “▲” or “▼” to adjust hour to “00”; Press “⊕” till to display “⊕” and “TIMER OFF” and all flash, and also “mm” flash, press “▲” or “▼” to adjust minute to “00”. press “⊕”, “hh” flash, press “▲” or “▼” to adjust hour to “00”.

DEFROST (LOW TEMPERATURE PROTECTION)

☞ Description: when the thermostat turns off and the room temperature is lower than 5°C, it will be turned on automatically in heating mode with “△” showing, under HR2008DA[E]/DB[E]/DA2[E]/DB2[E]/FCV2[E] models, the system will be in heat mode and fan runs in high speed. under HR2008Y[E] model, the motorized damper will be open. The thermostat will turn off when room temperature is higher than 7°C.

☞ Set low temperature protection: Turn off the thermostat, press “M” and hold for 3 seconds, it will display “00” or “01”, press “▲” or “▼” key to adjust. “00” indicates low temperature protection invalid, “01” indicates low temperature protection function valid. The default is “00”.

WIRING DIAGRAMS

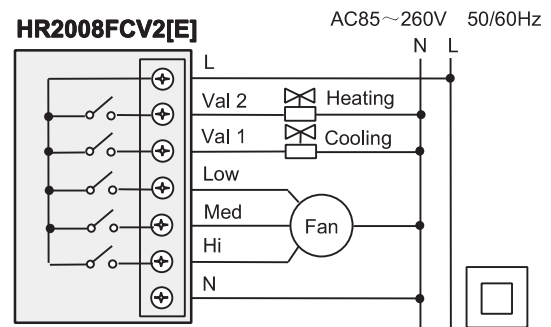
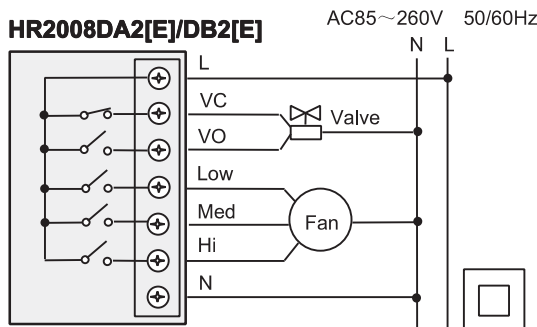
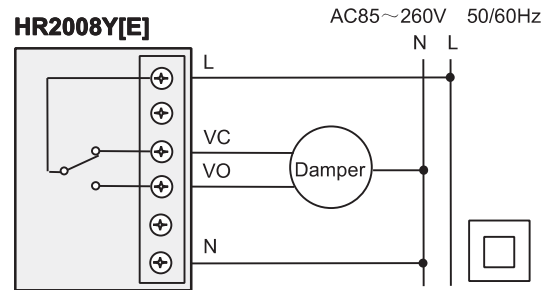
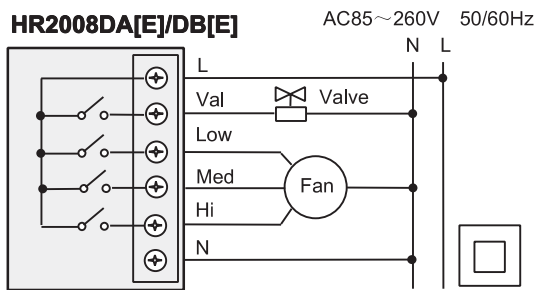

MOUNTING

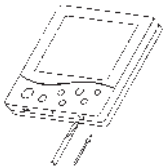
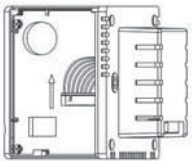
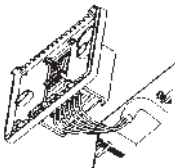
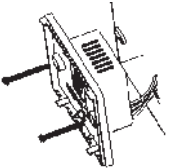
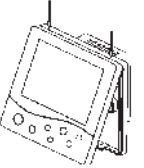
 <p>1. Open the main control panel: put the screwdriver (3.5mm) into the block 4mm along the bevel. Prize up, open the clips.</p>	 <p>2. Take off the wires.</p>	 <p>3. As per wiring diagram, connect it with terminals, fixed by the screwdriver.</p>	 <p>4. Put the connected thermostat onto the back panel in the wall, then fix it with the two screws in the packing box.</p>	 <p>5. Put the cover with 30 degree angle, then fix the up two clips; 6. Push the places of the two down clips, fix the cover, and finish the installation.</p>
--	---	---	--	--

Note: Be sure to connect all the wires as per the wiring diagrams and keep it away from water, mud and other material so as to prevent the unit being spoiled!

HR-G3 SERIES THREE-WAY MOTORIZED VALVES

General

HR-G3 series three-way motorized valves are used to control the cool/heat water flowing through or by pass the fan coil unit. When a thermostat sends the controlling signal to the motorized Valve, the valve is turned on to let water flow from C to B (Fig. 1), and when the signal disappears, the valve, with the help of its own spring, returns back to its original position to change the water flow from C to A(Fig. 2).

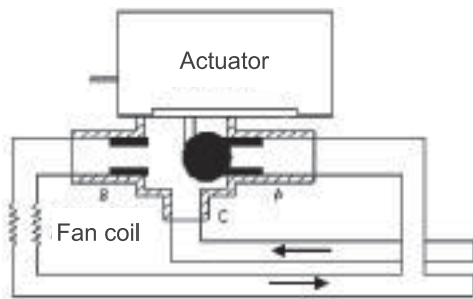

Fig.1

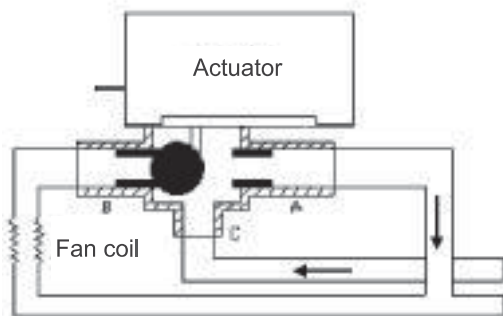
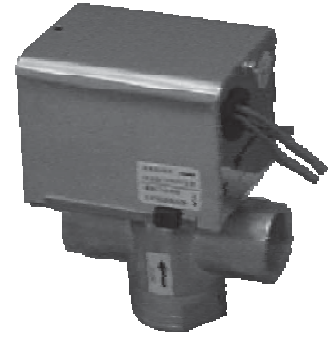

Fig.2



Features

- Forging Brass Body
- Stainless Base with Aluminum Shell
- Synchromotor Drive
- Efficient Power Consumption and Less Noise
- Separated Motorized Valve is easy to dismantle and install and convenient to use.

Model Listing

No.	Model	Caliber	Body Structure	Kv (Cv) Value	Closing Pressure (MPa)
1	HR-G3-1/2	1/2" (15mm)	Actuator and valve body fixed together	2.2 (2.5)	0.20
2	HR-G3-3/4	3/4" (20mm)		3.0 (3.5)	0.18
3	HR-G3-1	1" (25mm)		6.9 (8.0)	0.15
4	HR-G3-1/2-S2	1/2" (15mm)	Actuator is easily dismantled from valve body	2.2 (2.5)	0.20
5	HR-G3-3/4-S2	3/4" (20mm)		3.0 (3.5)	0.18
6	HR-G3-1-S2	1" (25mm)		6.9 (8.0)	0.15

Specifications

Power Supply : AC220V \pm 10%, 50/60Hz

Power Consumption: <7W

Pressure: 1.6MPa

Medium Temperature: 5~90°C

Valve Action Time: Open<10s, Return<6s

Working Environment: 5~60°C, 10%-95%RH

Dimension (mm)

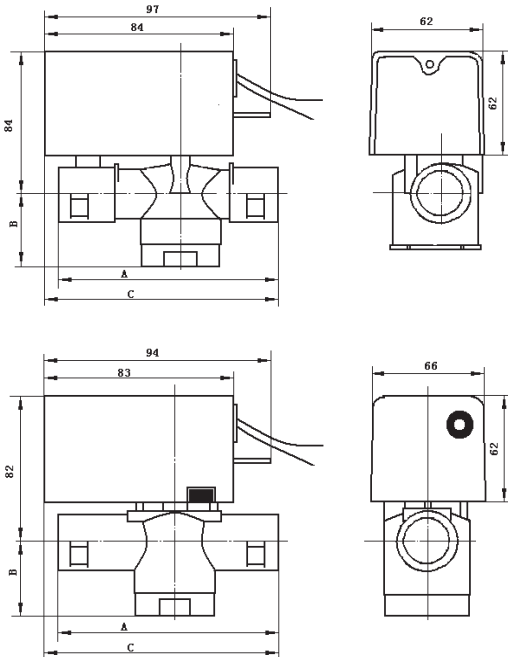

Model	A	B	C
HR-G3-1/2	90	33	94
HR-G3-3/4	94	37	103
HR-G3-1	96	43	105
HR-G3-1/2-S2	70	33	86
HR-G3-3/4-S2	87	37	93
HR-G3-1-S2	94	43	95

Installation

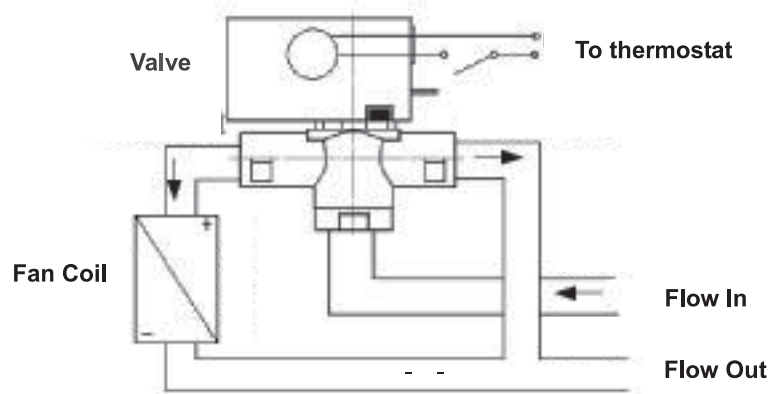

DIMENSIONS

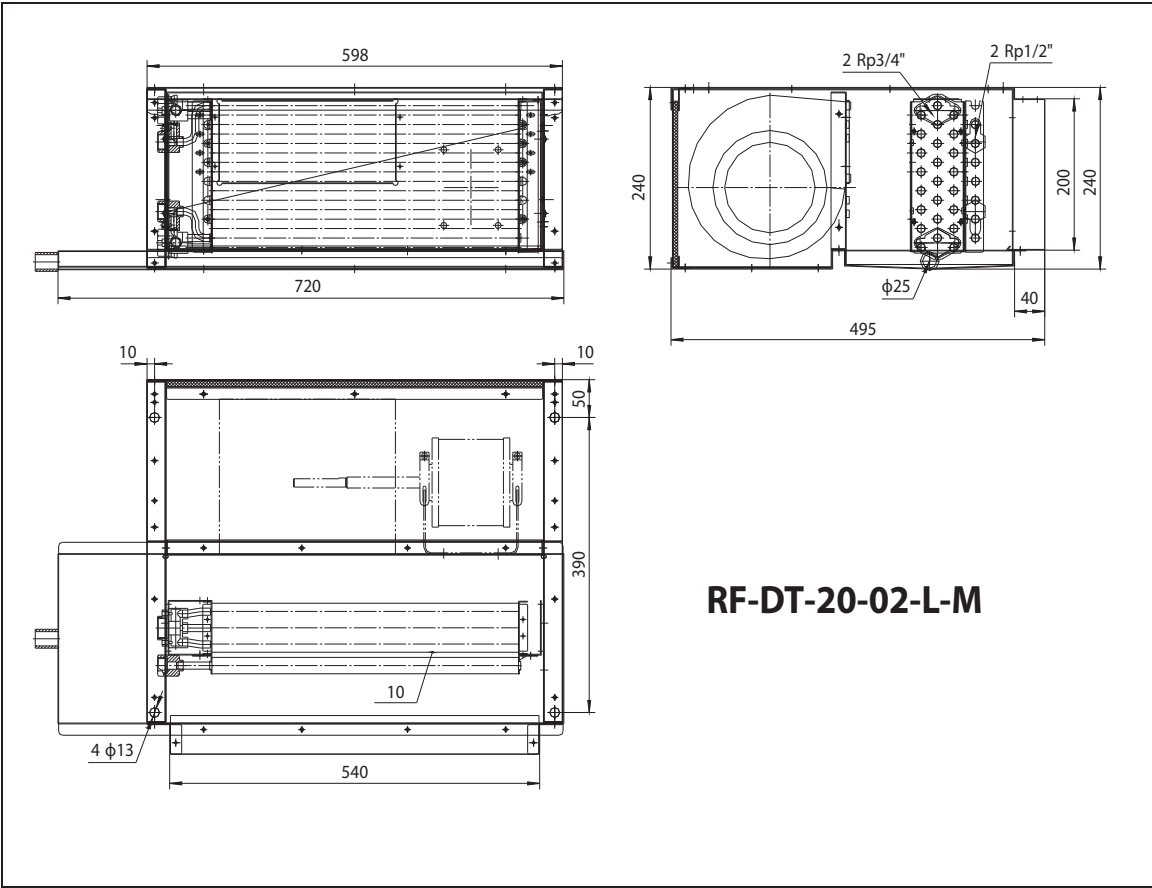

RF-DT-20-02-L-M

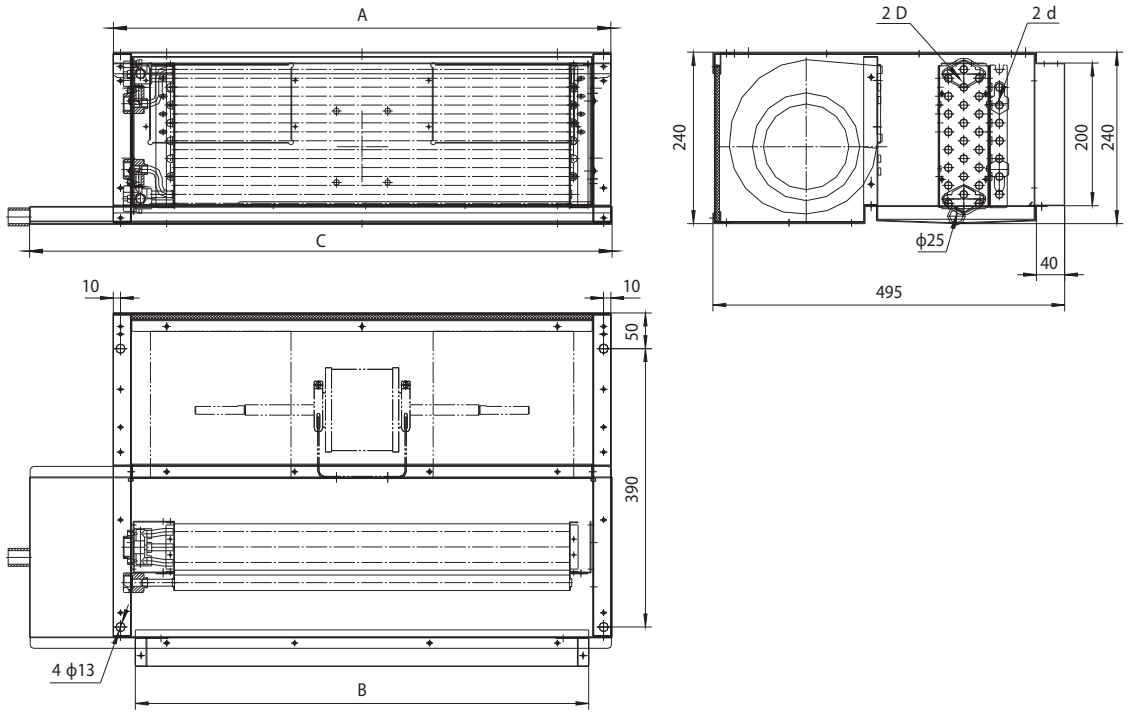

MODEL	-30-	-35-	-45-	-55-	-70-	-90-	-110-
A	648	798	948	998	1348	1498	1798
B	590	740	890	940	1290	1440	1740
C	770	920	1070	1120	1470	1620	1920
D	Rp3/4"	Rp3/4"	Rp3/4"	Rp3/4"	Rp3/4"	Rp3/4"	Rp3/4"
d	Rp1/2"	Rp1/2"	Rp1/2"	Rp1/2"	Rp1/2"	Rp1/2"	Rp1/2"

INSTALLATION

1) LOCATION

Before installation and running the unit, please check the following:

- i. There must be enough space for the unit installation and maintenance. Please refer to Figure 1 for the unit's outlines and dimensions and Figure 2 for the minimum distance between the unit and the obstacle.
- ii. Please ensure enough space for piping connection and electrical wiring.
- iii. Check whether the hanging rods can support weight of the unit (see specification table for weight of the unit).
- iv. The unit must be installed horizontally to ensure proper operation and condensate draining.
- v. The external static pressure of the ducting must be within the design static pressure range.
- vi. Confirm that the unit has been switched OFF before installing or servicing the unit.

2) UNIT INSTALLATION

- i. The unit is designed to be installed in a concealed ceiling. Installation and maintenance should be performed by qualified persons who are familiar with local codes and regulations, and experienced with this type of appliance.
- ii. Please refer to picture below illustrates the installation procedure.

Size	A mm	B mm
602-703	950	320
803-904	1100	320
1003-1104	1300	320

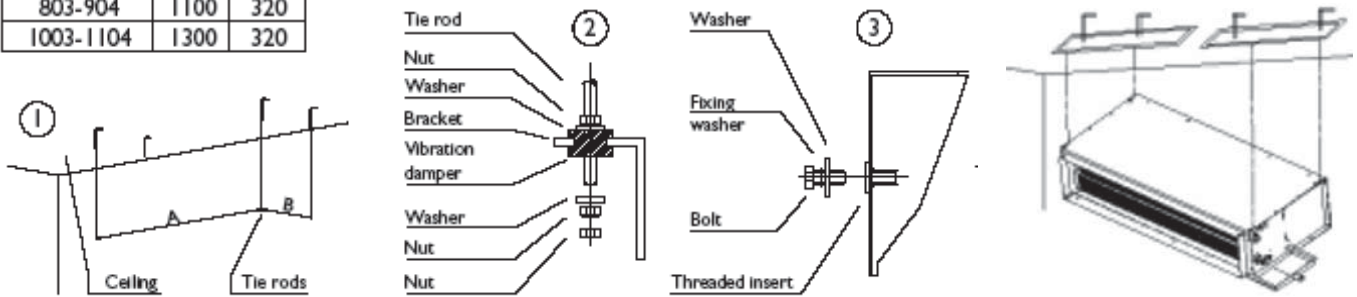

CAUTION:

Make sure the top of the unit is level after installation. The drain pan is designed with a little gradient to facilitate drainage.

4) PIPE CONNECTIONS

Make sure the diameter of the water pipes is adequate for the actual length of the piping and in any case not less than the diameter of the connection on the unit. When connecting the water pipes to the coil, take care not to damage the coil manifold. During this operation, hold the coil connections firm with a spanner to avoid damaging them.

The fittings are located on the back of the unit looking at the air outlets.

CONNECTING THE WATER PIPING

This operation must be carried out with particular care. The unit is fitted with a gravity drainage condensate drain pan with an open connection on the back of the unit. The pipe should have an internal diameter of at least 16 mm. The drain connection has an external diameter of 18 mm.

Proceed according to the following instructions (see figure).

1. Connect the condensate drain hose to the pan outlet with a hose clip.
2. Make sure the drain pipe has a slope of at least 2 cm/m without obstructions or bottlenecks.
3. Fit a siphon. By eliminating the pressure drop caused by the fan, this prevents air being sucked up by the drain hose.
4. Connect the condensate drain pipe to a rainwater drainage system. Do not connect to the sewage system as odors may be sucked up if the water in the siphon evaporates.
5. After connecting, check correct drainage of the condensate by pouring water into the pan.

MAINTENANCE

GENERAL

1. Installation and maintenance should be performed by qualified persons who are familiar with local codes and regulations, and experienced with this type of appliance.
2. Confirm that the unit has been switched OFF before installing or servicing the unit.
3. A good general maintenance plan will avoid losses and unexpected shutting down of the equipment.
4. Dirty filters reduce air flow as well as unit performance. Thus changing or cleaning the filters is very important. Check the cleanliness of filter and replace or clean as required monthly.
5. Coils should be cleaned from dust, dirt or lint with compressed air or water. They can be brushed with a soft brush and vacuum cleaner.
6. Water coil not used during winter season should be drained, or anti freezing solution should be added to the water circuit to avoid freezing.
7. Monthly:
 - a. Inspect and clean condensate drain pan to avoiding clogging of drainage by dirt, dust, etc. Inspect drainage piping to ensure the proper condensate flow.
 - b. Check and clean the coil. Clean the coils with low pressure water jet or low pressure air.
 - c. Clean and tighten all the wiring connections.
 - d. Drain out the system water and check for build up of mineral deposits.

FILTER CLEANING

1. Loosen the screws and remove the filter from the bottom.
2. Clean the filter with a brush, or with water.
3. Put back the filter by sliding it back into the groove.
4. Re tighten the filter side plate with screws.

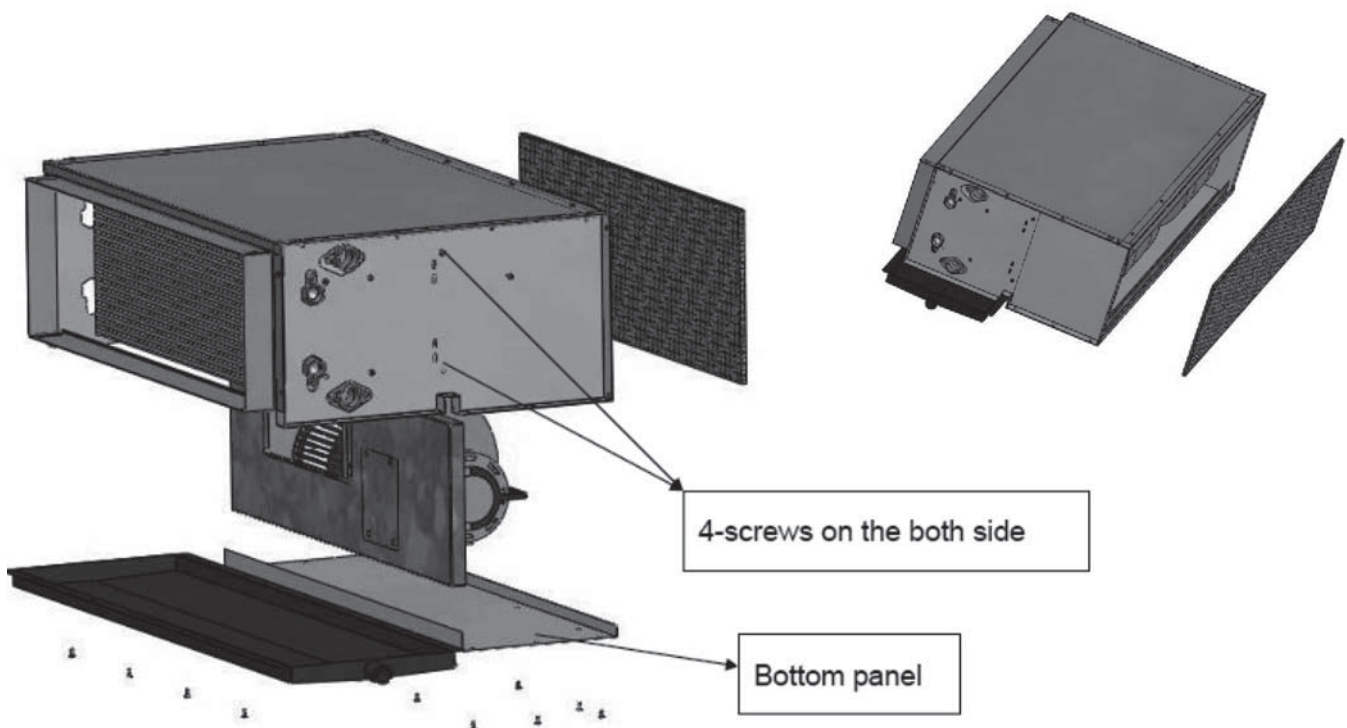

- a) Removing the bottom panel and the 4 screws which showed in the drawing, the motor and fan assembly can be taken out of the case.

