

TURBOCOR TECHNOLOGY  
**NEW!**

# TurboChill

## Air Cooled Chiller

### 500 kW - 1100 kW

### R134a

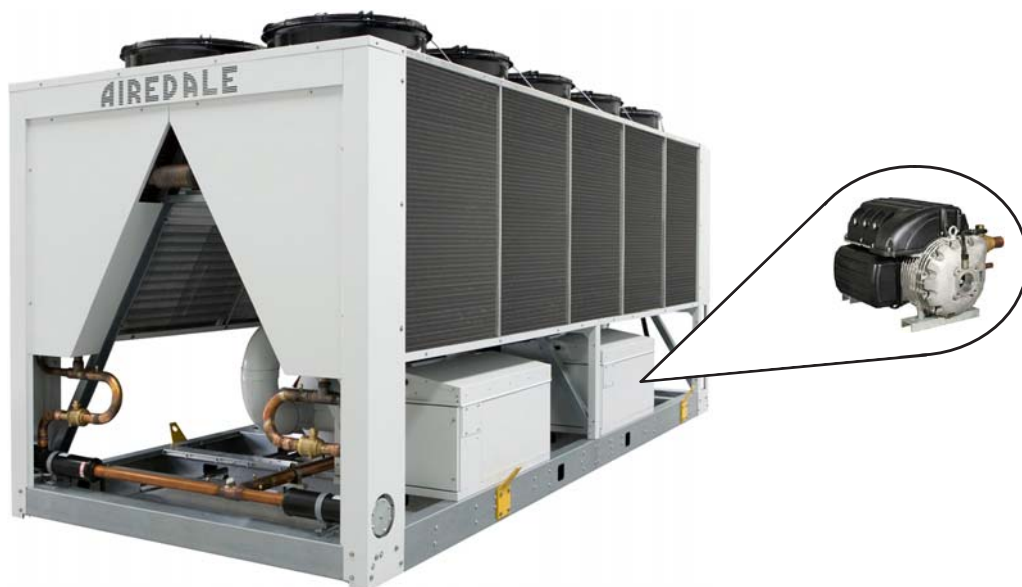

# INSTALLATION MANUAL



ISO 14001  
EMS52086



ISO 9001  
FM00542

## About Airedale Products & Customer Services

### WARRANTY, COMMISSIONING & MAINTENANCE

The equipment carries the Airedale **unit parts and labour warranty** in respect of non-consumable parts, for a period of **12 months** from the date of commissioning or **18 months** from the date of despatch which ever is the sooner. (Excludes the cost of any specialist access or lifting equipment.) Commissioning will be carried out by Airedale International Air Conditioning Ltd.

All Airedale products are designed in accordance with EU Directives regarding prevention of build up of water, associated with the risk of contaminants such as Legionella.

Where applicable, effective removal of condensate is achieved by gradient drainage to outlets and where used, humidification systems produce sterile, non-toxic steam during normal operation.

For effective prevention of such risk it is necessary that the equipment is maintained in accordance with Airedale recommendations.

### CAUTION

**Warranty cover is not a substitute for Maintenance. Warranty cover is conditional to maintenance being carried out in accordance with the recommendations provided during the warranty period. Failure to have the maintenance procedures carried out will invalidate the warranty and any liabilities by Airedale International Air Conditioning Ltd.**

### CHILLERGUARD SERVICE PLAN UK Mainland

To protect your investment in the highly efficient TurboChill, we provide as standard, a 12 months ChillerGuard Service Plan. Following site installation, an Airedale commissioning engineer will set the chiller to work and optimise the control settings in order to meet application design.

Once commissioned the ChillerGuard Service Plan provides a planned, preventative maintenance package to ensure optimum efficiency of the TurboChill.

A priority, 24/7 emergency helpline; professional support and call-out service is on hand throughout the year with guaranteed response by a fully qualified Airedale engineer. ChillerGuard also ensures you are F Gas compliant and incorporates a full parts and labour warranty for the first 12 months.

ChillerGuard packages can be tailored to include specific call out times and extended cover to meet your business needs.

For customers outside the UK, our international distributors trained by Airedale would be pleased to offer service on Airedale units.

### SPARES

A spares list for 1, 3 and 5 years will be supplied with every unit and is also available from our Spares department on request.

### TRAINING

As well as our comprehensive range of products, Airedale offers a modular range of Refrigeration and Air Conditioning Training courses, for further information please contact Airedale.

### CUSTOMER SERVICES

For further assistance, please e-mail: [enquiries@airedale.com](mailto:enquiries@airedale.com) or telephone:

<b>UK Sales Enquiries</b>	+ 44 (0) 113 238 7789	<a href="mailto:uk.sales@airedale.com">uk.sales@airedale.com</a>
<b>International Enquiries</b>	+ 44 (0) 113 239 1000	<a href="mailto:enquiries@airedale.com">enquiries@airedale.com</a>
<b>Spares Hot Line</b>	+ 44 (0) 113 238 7878	<a href="mailto:spares@airedale.com">spares@airedale.com</a>
<b>Airedale Service</b>	+ 44 (0) 113 239 1000	<a href="mailto:service@airedale.com">service@airedale.com</a>
<b>Technical Support</b>	+ 44 (0) 113 239 1000	<a href="mailto:tech.support@airedale.com">tech.support@airedale.com</a>
<b>Training Enquiries</b>	+ 44 (0) 113 239 1000	<a href="mailto:marketing@airedale.com">marketing@airedale.com</a>

For information, visit us at our Web Site: [www.airedale.com](http://www.airedale.com)

AIAC Ltd endeavours to ensure that the information in this document is correct and fairly stated, but none of the statements are to be relied upon as a statement or representation of fact. AIAC Ltd does not accept liability for any error or omission, or for any reliance placed on the information contained in this document.

The development of Airedale products and services is continuous and the information in this document may not be up to date. It is important to check the current position with AIAC Ltd at the address stated. This document is not part of a contract or licence unless expressly agreed.

No part of this document may be reproduced or transmitted in any form or by any means, electronic or mechanical, including photocopying, recording, or information storage and retrieval systems, for any purpose other than the purchaser's personal use, without the express written permission of AIAC Ltd.

© 2008 Airedale International Air Conditioning Limited. All rights reserved. Printed in the UK.

## Contents

<b>General Statement</b>	<b>4</b>
<b>Warranty</b>	<b>5</b>
<b>General Description</b>	<b>6</b>
Unit Identification	6
Introduction	6
Standard Features	7
Optional Extras	9
<b>Dimensional Data</b>	<b>10</b>
<b>Installation Data</b>	<b>12</b>
Weights, Point Loadings & Centre of Gravity (C of G)	12
Unit Lifting	14
Anti Vibration Mounting (Optional)	15
Anti Vibration Mounting (Optional) - Allocation	16
Positioning	18
Airflow & Maintenance Clearances	18
Water System	19
Grooved & Clamped Type Connection	19
Standard Recommended Installation	20
Glycol Data	22
Waterside Pressure Drop (kPa)	23
Electrical	24
Electrical Data	25
Interconnecting Wiring	25

## General Statement



**IMPORTANT**  The information contained within this manual is critical to the correct installation of the unit prior to commissioning. The manual should be used in conjunction with the supporting design application specification.

Please read carefully before commencing.

Following completion of installation, Airedale or an approved Airedale company will complete and certify commissioning of the unit.

### SAFETY

The equipment has been designed and manufactured to meet international safety standards but, like any mechanical/electrical equipment, care must be taken if you are to obtain the best results.

- CAUTION**  **1 Installation, service and maintenance of Airedale equipment should only be carried out by technically trained competent personnel.**
- CAUTION**  **2 When working with any air conditioning units ensure that the electrical isolator is switched off prior to servicing or repair work and that there is no power to any part of the equipment.**
- 3 Also ensure that there are no other power feeds to the unit such as fire alarm circuits, BMS circuits etc.
- 4 Electrical installation commissioning and maintenance work on this equipment should be undertaken by competent and trained personnel in accordance with local relevant standards and codes of practice.
- 5 The refrigerant used in this range of products is classified under the COSHH regulations as an irritant, with set Occupational Exposure Levels (OEL) for consideration if this plant is installed in confined or poorly ventilated areas.
- 6 A full hazard data sheet in accordance with COSHH regulations is available should this be required.

### SPARES

For ease of identification when ordering spares or contacting Airedale about your unit, please quote the unit type, unit serial number and the date of manufacture, which can be found on the unit serial plate.

A spares list for 1, 3 and 5 years will be supplied with every unit and is also available from our Spares department on request.

### SERIAL PLATE

The serial plate can be located to the inside of the control panel door.



UK Office ☎ + 44 113 2391000 📠 + 44 113 2507219

Unit/Gerät/Unite	TTC12B112X95
Serial/Serie/Serie	81543668-001 (63091072)
Manufactured/Hergestellt/Fabriqué	24/01/2007
Supply/Spannung/Alimentation	400 V 3 PH 50 Hz
Fuse/Hauptsicherung/Fusibles	25.0 A
Test Pressure Prüfdruck Pression d'essai	27.0 BAR
Refrigerant & Charge Kältemittel und Füllung Refrigerant & Charge	
Max. operating pressure Betriebsdruck (Maximal) Pression de marche (Maximum)	
N.B. No: 0086	

www.airedale.com

CE

## Warranty

### GENERAL

To be read in conjunction with Airedale International Air Conditioning Ltd standard Conditions of Sale and any related quotation.

The equipment carries Airedale's standard **Parts** (non consumable) & **Labour** warranty for a period of **12 months** from the date of commissioning or **18 months** from the date of despatch, whichever is the sooner. Commissioning must be carried out by Airedale or an approved Airedale company.

### WARRANTY IS ONLY VALID IN THE EVENT THAT:

- 1 In the period between delivery and commissioning the equipment:  
is properly protected & serviced  
water flow safety devices are in place and fully operational
- 2 The equipment is serviced and maintained by Airedale or an approved Airedale company in accordance with the Installation, Commissioning & Maintenance information provided, during the Warranty Period.

In the event of a problem being reported, Airedale will cover the full cost of rectification (excluding costs for any specialist access or lifting equipment) if warranty is valid under these conditions.

Any spare part supplied by Airedale under the warranty shall be warranted for the unexpired period of the warranty or 3 months from delivery whichever period is the longer, with the exception of compressors on which a further 12 months warranty is granted.

### PROCEDURE

- The on site contractor or service company place an official order on Airedale for the replacement part including site labour if required. Airedale will acknowledge this order with detailed prices for components, travel and labour rates.
- Should warranty be accepted, following inspection of the faulty component, a credit note will be issued against the invoice raised in line with the acknowledgement.
- Should warranty be refused the invoice raised against the acknowledgement becomes payable on normal terms.
- Airedale reserves the right to carry out site warranty labour work using their own direct labour or by sub contracting to an approved company of their choice.

### EXCLUSIONS

Warranty may be refused for the following reasons:

- Misapplication of product or component
- Incorrect site installation
- Incomplete commissioning documentation
- Inadequate site installation
- Inadequate site maintenance
- Damage caused by mishandling
- Replaced part being returned damaged without explanation
- Unnecessary delays incurred in return of defective component

### GENERAL

Dead on arrival or manufacturing defects are the responsibility of Airedale and should be reported immediately.

In the event of a warranty failure, dead on arrival or manufacturing defect, the Airedale Service department should be contacted and on receipt of an order, an Airedale engineer (or representative) will be directed to site as soon as possible.

### RETURNS ANALYSIS

All faulty components returned under warranty are analysed on a monthly basis as a means of verifying component and product reliability as well as supplier performance. It is important that all component failures are reported correctly.

## General Description

### UNIT IDENTIFICATION

	<b>TTC1</b>	<b>2</b>	<b>B1</b>	<b>12X</b>	<b>95</b>
TurboChill - Single Circuit Chiller with Centrifugal Compressor					
Number of Turbocor Compressors					
Evaporator Code					
Number of Fans					
Fan Speed (x10 rpm, ie 950 rpm)					

### INTRODUCTION

The Airedale range of TurboChill air cooled liquid chillers uses the technologically superior centrifugal Turbocor compressors. Designed to cover the high capacity range of between 500kW and 1100kW and offering over 200 model variations.

Each single circuit model is individually selected to provide the optimum solution for each application by offering maximum flexibility and matching customer requirements in terms of:

- Capacity
- EER/ESEER
- Sound Levels - Quiet TTC ... 95 and Super Quiet ... 70
- Footprint
- Pressure Drop
- Commercial considerations

### REFRIGERANTS

The range has been designed and optimised for operation with ozone benign R134a refrigerant.

### CE DIRECTIVE



Airedale certify that the equipment detailed in this manual conforms with the following EC Directives:

Electromagnetic Compatibility Directive (EMC)	<b>2004/108/EC</b>
Low Voltage Directive (LVD)	<b>73/23/EEC</b>
Machinery Directive (MD)	<b>89/392/EEC in the version 98/37/EC</b>
Pressure Equipment Directive (PED)	<b>97/23/EC</b>

To comply with these directives appropriate national & harmonised standards have been applied. These are listed on the Declaration of Conformity, supplied with each product.

## General Description

### Construction

The base is fabricated from galvanised steel to ensure a rigid, durable, weatherproof construction.

Unit panels are manufactured from galvanised sheet steel coated with epoxy baked powder paint to provide a durable and weatherproof finish.

Standard unit colour is Light Grey (RAL 7035).

Compressors and evaporator are mounted on a rigid galvanised heavy-duty sub frame. Fully weatherproofed electrical panels are situated at one end of the unit.

Fitted with acoustically lined compressor enclosures as standard.

### STANDARD FEATURES

#### Features

The High Efficiency Quiet TurboChill chiller comes complete with:

- Multiple Turbocor Oil Free Compressors
- **AIRE**Tronix Microprocessor Control
- Single Pass Shell & Tube Evaporator with Immersion heater & Thermostat
- Single Refrigeration Circuit
- Acoustically Lined compressor enclosure
- Electronic Expansion Valve (EEV)
- Intelligent Head Pressure Control
- Electronically Commutated (EC) Sickle Bladed fans with Long Bellmouth
- Pressure Relief Valves - Per Compressor
- Grooved water connections & counter pipe assembly
- Connections for External Trace Heating (230V/500W available)

#### Compressor

Turbocor centrifugal compressor supplied with as standard:

- Vibration isolating rubber mounts
- Suction strainer
- Suction and discharge shut off valves
- Discharge non-return valve
- Line reactor (for removing additional impedance harmonics and voltage spikes in the ac waveform)
- EMI/EMC filter

and comprising of:

- AC-DC rectifier
- DC capacitors
- DC-AC (IGBT) converter
- Motor/bearing management system and incorporating surge protection
- Soft start module
- Magnetic bearing system

The compressors are mounted on Turbocor specially designed vibration reducing isolation.

Linear capacity modulation is provided by a variable frequency drive (VFD).

For further details please refer to Airedale.

## General Description

### Refrigeration

Each refrigeration circuit is supplied with the following:

- Full operating charge of R134a
- Liquid injection cooling circuit fitted to each compressor as standard with sight glass, filter drier, solenoid valve and ball valve
- Electronic Expansion Valves (EEV)
- Discharge line shut off valve - Per compressor
- Suction line shut off valve - Per compressor
- Liquid line shut off valve(s)
- Large capacity filter drier(s) with replaceable cores
- Liquid line sight glass(s)
- Low pressure switch with Auto reset
- High pressure switch with manual reset - Per compressor
- Suction and liquid pressure transducers
- Suction line strainer - Per compressor
- Hot gas load balancing valve
- Discharge check (non return) valve - Per compressor

### Controls

As standard, the **AIRETronix** microprocessor controller can provide an infinite capacity control between 7.5% and 100%, depending on the component selection.

Optionally, the controller is designed to provide capabilities for;

- Building Management Systems (BMS)
- Sequencing (Master/Slave and Run/Standby)

to meet all your system requirements, ***please specify at time of enquiry.***

### Electrical

A weatherproof electrical power and controls panel is situated at the end of the unit and contains:

- Individual mains power isolator for each compressor
- Separate door locking electrical isolation for fan mains compartment
- Dedicated bus-bar chamber for connection of incoming 3-phase and earth mains power supply
- Emergency Stop fitted to compressor mains compartment door
- Separate, fully accessible, controls compartment, allowing adjustment of control set points whilst the unit is operational
- Circuit breakers for protection of all major unit components
- Phase rotation relay incorporating phase loss protection

} refer to  
**Interconnecting  
Wiring**, on page 25

The electrical power and control panel is wired to the latest European standards and codes of practice.

Mains supply is 3 phase and a neutral is not required, refer to **Interconnecting Wiring**, on page 25.

Separate 230V permanent supply is required for the controls and safety features.

Electrical terminals for external evaporator pipework trace heating (230V/500W) are provided.

### CAUTION

**Unit controls supply is supported by an on board UPS to ensure control operation is maintained in the event of a system shut down in a power failure situation. Power will be maintained until mains power is reinstated for a maximum period of 10 minutes.**

For further electrical information refer to **Electrical Data**, on page 25.



## General Description

### OPTIONAL EXTRAS

#### Loose Item

- Anti Vibration Mounts - Instructions supplied with item
- Flow Switch
- Chiller Sequence Manager

#### CAUTION



**It is only possible to set up a sequencing following completion of interconnecting communication wiring. Airedale Service can arrange sequence setup on request (UK Mainland).**

#### Factory Fitted

- Corrosion Resistant Coated Coils
- Coil Guards
- Discharge Air Plenum - Condenser Fan
- Extended Discharge Air Plenum - Condenser Fan
- Maintainable Dual Pressure Relief Valve
- R134a Leak Detection System
- Evaporator Differential Pressure Sensor
- Remote Setpoint Adjust
- BMS Interface Card

#### Optional Unit Cover

Chillerguard® Maintenance<sup>(1)</sup>  
(For details and a competitive quotation, contact Airedale Service.)

(1) UK Mainland Sites

Dimensional Data

**IMPORTANT**



The following information is for general guidance; please refer to the certified drawings provided for installation.

Grooved Water Connections:  
DN200 PN16 (219.1mm)

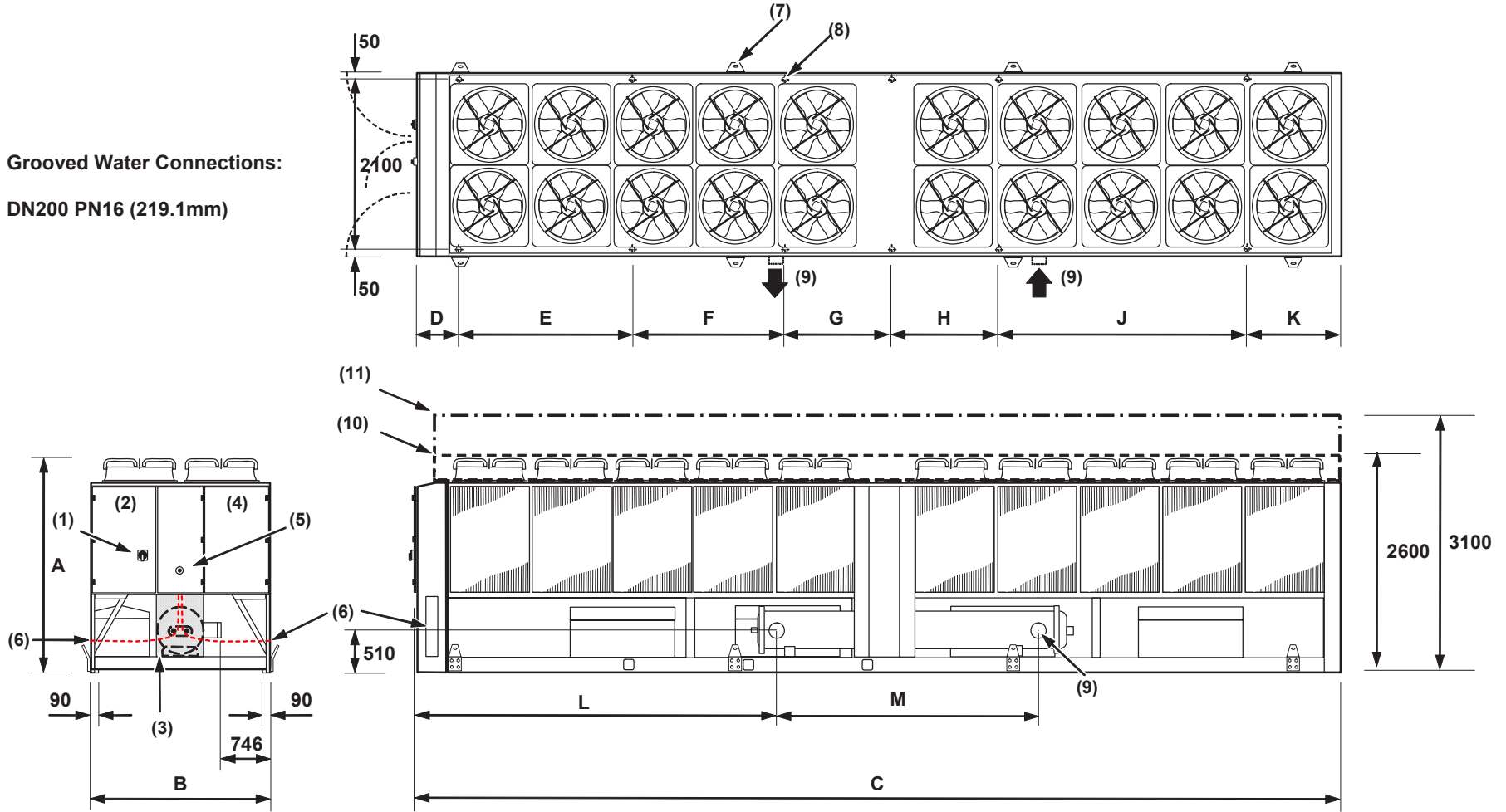

		A	B	C	D	E	F	G	H	J	K	L	M
TCC1xxx08Xxx	mm	2600	2200	4675	500	1250	1250	1250	-	-	425	1082	2360
TCC1xB110Xxx	mm	2600	2200	5676	500	1750	1250	1750	-	-	425	1582	2360
TCC1xB210Xxx	mm	2600	2200	5676	500	1750	1250	1750	-	-	425	1582	2360
TCC1xC110Xxx	mm	2600	2200	5676	500	1750	1250	1750	-	-	425	1307	2910
TCC1xD110Xxx	mm	2600	2200	5676	500	1750	1250	1750	-	-	425	1157	3210
TCC1xD210Xxx	mm	2600	2200	5676	500	1750	1250	1750	-	-	425	1157	3210
TCC1xB112Xxx	mm	2600	2200	7100	500	1850	1200	1175	1775	-	600	2730	2360
TCC1xB212Xxx	mm	2600	2200	7100	500	1850	1200	1175	1775	-	600	2730	2360
TCC1xC112Xxx	mm	2600	2200	7100	500	1850	1200	1175	1775	-	600	2455	2910
TCC1xD112Xxx	mm	2600	2200	7100	500	1850	1200	1175	1775	-	600	2305	3210
TCC1xD112Xxx	mm	2600	2200	7100	500	1850	1200	1175	1775	-	600	2305	3210
TCC1xB114Xxx	mm	2600	2200	8100	500	2000	1400	1400	2000	-	800	2730	2360
TCC1xB214Xxx	mm	2600	2200	8100	500	2000	1400	1400	2000	-	800	2730	2360
TCC1xC114Xxx	mm	2600	2200	8100	500	2000	1400	1400	2000	-	800	2455	2910
TCC1xD114Xxx	mm	2600	2200	8100	500	2000	1400	1400	2000	-	800	2305	3210
TCC1xD214Xxx	mm	2600	2200	8100	500	2000	1400	1400	2000	-	800	2305	3210
TCC1xB116Xxx	mm	2600	2200	9100	500	2875	1400	1400	2325	-	600	3730	2360
TCC1xB216Xxx	mm	2600	2200	9100	500	2875	1400	1400	2325	-	600	3730	2360
TCC1xC116Xxx	mm	2600	2200	9100	500	2875	1400	1400	2325	-	600	3455	2910
TCC1xD116Xxx	mm	2600	2200	9100	500	2875	1400	1400	2325	-	600	3305	3210
TCC1xD216Xxx	mm	2600	2200	9100	500	2875	1400	1400	2325	-	600	3305	3210
TCC1xB118Xxx	mm	2600	2200	10100	500	3000	1400	1400	3000	-	800	3730	2360
TCC1xB218Xxx	mm	2600	2200	10100	500	3000	1400	1400	3000	-	800	3730	2360
TCC1xC118Xxx	mm	2600	2200	10100	500	3000	1400	1400	3000	-	800	3455	2910
TCC1xD118Xxx	mm	2600	2200	10100	500	3000	1400	1400	3000	-	800	3305	3210
TCC1xD218Xxx	mm	2600	2200	10100	500	3000	1400	1400	3000	-	800	3305	3210
TCC1xB120Xxx	mm	2600	2200	11100	500	2000	2000	1400	1400	2700	1100	4730	2360
TCC1xB220Xxx	mm	2600	2200	11100	500	2000	2000	1400	1400	2700	1100	4730	2360
TCC1xC120Xxx	mm	2600	2200	11100	500	2000	2000	1400	1400	2700	1100	4455	2910
TCC1xD120Xxx	mm	2600	2200	11100	500	2000	2000	1400	1400	2700	1100	4305	3210
TCC1xD220Xxx	mm	2600	2200	11100	500	2000	2000	1400	1400	2700	1100	4305	3210

- (1) Fan Electric Isolator(s), for unit isolation refer to (6).
- (2) Mains Electric Panel(s), for unit isolation refer to (6).
- (3) Bus Bar Chamber / Compressor Isolation (Inside) Electric Panel(s), for unit isolation refer to (6).
- (4) Microprocessor Control Panel.
- (5) Emergency Stop.
- (6) **Mains Cable Entry and route to Busbar, unit incoming mains isolation supplied by others.**
- (7) Lifting Lugs (removable): Hole 40mm Ø
- (8) 20mm Ø Mounting Holes:
 

12 - 18 Fan Unit	x 10
20 Fan Unit	x 12
- (9) **Water Connections; grooved pipe, supplied with clamp for coupled connections and a 100mm length of counter pipe for welded connections.**
- (10) Optional discharge plenum
- (11) Optional discharge plenum extension
- (12) Water connections exit from right hand side of unit as standard, optionally connections can exit from left on request, *please specify at time of enquiry.*

# Installation Data

## WEIGHTS, POINT LOADINGS & CENTRE OF GRAVITY (C OF G)

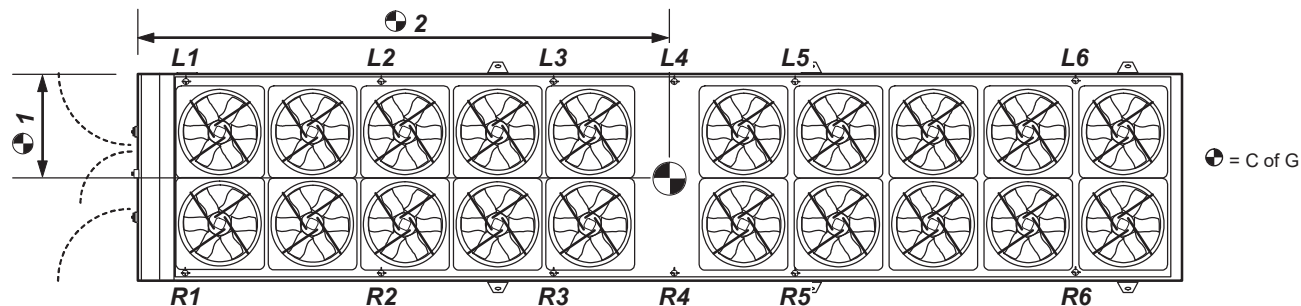

	Operating Weight (kg)	Point Loadings (kg) (Rounded to nearest 5kg)												C of G (mm)	
		L1	L2	L3	L4	L5	L6	R1	R2	R3	R4	R5	R6	1	2
TTC12B108Xxx	5600	810	750	750	590	-	-	790	680	680	550	-	-	1060	2220
TTC12B110Xxx	5960	840	810	790	640	-	-	820	730	740	590	-	-	1060	2700
TTC12B112Xxx	6330	680	705	690	760	430	-	680	635	630	690	430	-	1070	3230
TTC12B114Xxx	6650	710	765	725	765	460	-	710	695	660	695	460	-	1070	3640
TTC12B116Xxx	6970	745	785	755	815	495	-	745	720	695	730	495	-	1070	4400
TTC12B118Xxx	7290	775	830	785	830	525	-	775	760	725	760	525	-	1070	4600
TTC12B120Xxx	7610	715	465	770	725	770	465	715	465	695	665	695	465	1070	4970
TTC12B208Xxx	5590	810	750	750	590	-	-	790	675	675	550	-	-	1060	2220
TTC12B210Xxx	5940	835	810	790	640	-	-	815	725	740	585	-	-	1060	2700
TTC12B212Xxx	6310	675	705	690	760	425	-	675	630	625	690	425	-	1070	3230
TTC12B214Xxx	6640	710	765	720	765	460	-	710	695	660	695	460	-	1070	3640
TTC12B216Xxx	6960	740	780	755	815	490	-	740	720	690	730	490	-	1070	4400
TTC12B218Xxx	7280	775	830	785	830	525	-	775	755	725	755	525	-	1070	4600
TTC12B220Xxx	7590	715	465	770	725	770	465	715	465	695	660	695	465	1070	4970
TTC12C110Xxx	6010	835	825	810	640	-	-	815	745	760	585	-	-	1060	2710
TTC12C112Xxx	6380	670	720	705	785	420	-	670	645	640	710	420	-	1060	3240
TTC12C114Xxx	6700	700	785	735	785	450	-	700	710	675	710	450	-	1070	3650
TTC12C116Xxx	7020	735	800	770	830	485	-	735	740	705	750	485	-	1070	4400
TTC12C118Xxx	7340	765	845	800	845	515	-	765	775	740	775	515	-	1070	4600
TTC12C120Xxx	7660	705	455	790	740	790	455	705	455	715	680	715	455	1070	4990
TTC12D110Xxx	6060	835	835	825	640	-	-	815	755	775	585	-	-	1060	2710
TTC12D112Xxx	6430	665	730	715	800	415	-	665	655	650	725	415	-	1060	3240
TTC12D114Xxx	6760	695	795	745	795	445	-	695	725	685	725	445	-	1070	3650
TTC12D116Xxx	7080	730	815	780	845	480	-	730	750	715	760	480	-	1070	4410
TTC12D118Xxx	7400	760	860	810	860	510	-	760	790	750	790	510	-	1070	4600
TTC12D120Xxx	7720	700	450	805	755	805	450	700	450	730	690	730	450	1070	5000
TTC12D210Xxx	6050	835	835	825	635	-	-	810	755	770	585	-	-	1060	2710
TTC12D212Xxx	6420	660	730	715	800	410	-	660	655	650	725	410	-	1060	3240
TTC12D214Xxx	6750	695	795	745	795	445	-	695	725	685	725	445	-	1070	3650
TTC12D216Xxx	7070	725	815	780	845	475	-	725	750	715	760	475	-	1070	4410
TTC12D218Xxx	7390	760	860	810	860	510	-	760	790	750	790	510	-	1070	4600
TTC12D220Xxx	7700	700	450	800	750	800	450	700	450	730	690	730	450	1070	5000

	Operating Weight (kg)	Point Loadings (kg) (Rounded to nearest 5kg)											C of G (mm)		
		L1	L2	L3	L4	L5	L6	R1	R2	R3	R4	R5	R6	⊕ 1	⊕ 2
TTC13B112Xxx	6820	825	740	740	800	460	-	745	665	665	720	460	-	1050	3180
TTC13B114Xxx	7140	855	825	775	780	490	-	780	735	695	715	490	-	1050	3580
TTC13B116Xxx	7500	870	860	810	840	525	-	805	770	735	760	525	-	1060	4340
TTC13B118Xxx	7820	900	895	840	870	560	-	840	800	765	795	560	-	1060	4550
TTC13B120Xxx	8150	740	630	805	755	805	490	740	540	725	690	725	490	1060	4920
TTC13B212Xxx	6800	820	740	740	795	455	-	745	665	665	720	455	-	1050	3180
TTC13B214Xxx	7130	855	825	775	780	490	-	775	730	695	715	490	-	1050	3580
TTC13B216Xxx	7480	865	860	810	835	525	-	805	765	730	760	525	-	1060	4340
TTC13B218Xxx	7810	900	895	840	870	555	-	840	800	765	790	555	-	1060	4540
TTC13B220Xxx	8130	740	630	805	750	805	490	740	535	725	690	725	490	1060	4920
TTC13C112Xxx	6870	815	755	755	820	445	-	735	680	680	740	445	-	1050	3180
TTC13C114Xxx	7190	845	845	785	795	480	-	770	750	710	735	480	-	1060	3580
TTC13C116Xxx	7550	860	880	825	855	515	-	795	785	745	780	515	-	1060	4340
TTC13C118Xxx	7870	890	910	855	885	545	-	830	820	780	810	545	-	1060	4540
TTC13C120Xxx	8200	735	625	825	770	825	485	735	530	745	705	745	485	1060	4940
TTC13D112Xxx	6930	810	765	765	835	440	-	730	690	690	760	440	-	1050	3190
TTC13D114Xxx	7250	840	855	800	810	475	-	765	765	720	750	475	-	1060	3580
TTC13D116Xxx	7610	855	890	835	870	510	-	790	800	755	790	510	-	1060	4340
TTC13D118Xxx	7930	885	925	865	900	540	-	825	830	790	825	540	-	1060	4540
TTC13D120Xxx	8250	730	620	840	780	840	480	730	525	760	720	760	480	1060	4950
TTC13D212Xxx	6910	805	765	765	835	440	-	730	685	685	755	440	-	1050	3190
TTC13D214Xxx	7240	840	855	800	810	475	-	760	765	720	745	475	-	1050	3580
TTC13D216Xxx	7590	850	890	835	870	510	-	790	800	755	790	510	-	1060	4350
TTC13D218Xxx	7910	885	925	865	900	540	-	820	830	785	820	540	-	1060	4550
TTC13D220Xxx	8240	725	615	835	780	835	475	725	525	760	715	760	475	1060	4950
TTC14B112Xxx	7430	870	790	790	845	620	-	790	710	710	765	540	-	1040	3250
TTC14B114Xxx	7830	910	860	830	860	660	-	830	775	750	775	580	-	1050	3680
TTC14B116Xxx	8170	885	925	865	890	725	-	845	820	780	810	625	-	1050	4480
TTC14B118Xxx	8540	950	960	900	960	700	-	890	855	820	855	640	-	1050	4640
TTC14B120Xxx	8860	785	660	885	825	855	625	785	575	780	745	770	565	1050	5010
TTC14B212Xxx	7410	870	790	790	845	620	-	785	705	705	760	535	-	1040	3250
TTC14B214Xxx	7810	910	855	830	855	660	-	825	775	745	775	575	-	1040	3680
TTC14B216Xxx	8150	880	920	860	890	725	-	840	820	780	810	620	-	1050	4480
TTC14B218Xxx	8520	950	960	900	960	700	-	890	855	815	855	640	-	1050	4640
TTC14B220Xxx	8850	785	655	885	825	855	625	785	575	780	745	770	565	1050	5010
TTC14C112Xxx	7480	860	805	805	865	610	-	780	720	720	785	530	-	1040	3250
TTC14C114Xxx	7880	900	875	845	875	650	-	820	795	760	795	570	-	1050	3680
TTC14C116Xxx	8220	875	940	875	910	715	-	830	835	795	825	615	-	1050	4480
TTC14C118Xxx	8590	940	975	915	975	690	-	880	875	830	875	630	-	1050	4640
TTC14C120Xxx	8910	775	650	905	840	875	620	775	565	800	760	790	555	1050	5030
TTC14D112Xxx	7530	855	815	815	885	605	-	775	730	730	800	525	-	1040	3260
TTC14D114Xxx	7930	895	890	855	890	645	-	815	805	770	805	565	-	1050	3690
TTC14D116Xxx	8270	870	955	890	920	710	-	825	850	805	840	605	-	1050	4480
TTC14D118Xxx	8640	935	990	925	990	685	-	875	885	840	885	625	-	1050	4650
TTC14D120Xxx	8970	770	645	920	855	890	615	770	565	815	770	805	550	1050	5040
TTC14D212Xxx	7520	855	815	815	880	605	-	770	730	730	800	520	-	1040	3260
TTC14D214Xxx	7920	895	890	855	890	645	-	810	805	770	805	560	-	1040	3690
TTC14D216Xxx	8260	865	955	885	920	710	-	825	850	805	840	605	-	1050	4490
TTC14D218Xxx	8630	935	990	925	990	685	-	870	885	840	885	620	-	1050	4640
TTC14D220Xxx	8950	770	645	920	850	885	610	770	560	815	770	805	550	1050	5040

## Installation Data

### UNIT LIFTING

- **Employ lifting specialists**
- Local codes and regulations relating to the lifting of this type of equipment should be observed
- Use the appropriate spreader bars/lifting slings (provided by others) with the eye bolts/lugs provided
- Attach individual lifting chains to each of the lifting eye bolts/lifting lugs provided; each individual chain must be capable of lifting the whole unit
- Lifting eye bolt/lug dimension: 40mm

### IMPORTANT



**Do not use 1 chain between 2 lifting points to avoid load shift.**

**Only use lifting points provided.**

**Chains/slings MUST NOT interfere with the casing or fan assembly to avoid damage.**

**Lift the unit slowly and evenly.**

**If the unit is dropped, it should immediately be checked for damage and reported to Airedale.**

### LIFTING DIMENSIONS

#### 8 - 10 Fan

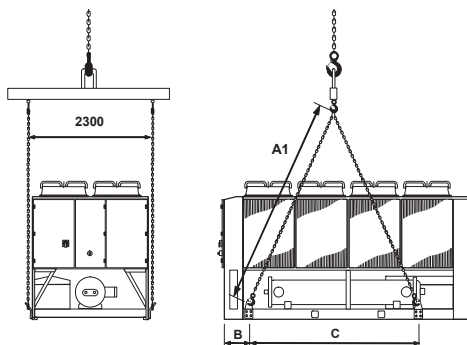

#### 12 - 20 Fan

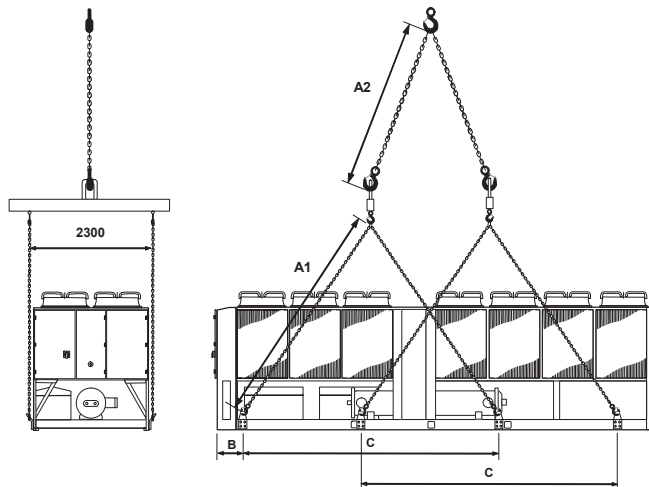

		A1 (Min)	A2 (Min)	B	C
TCC1xxx08Xxx	mm	4000	N/A	520	3200
TCC1xxx10Xxx	mm	4000	N/A	846	3500
TCC1xxx12Xxx	mm	4000	5000	520	4000
TCC1xxx14Xxx	mm	5000	5000	520	4650
TCC1xxx16Xxx	mm	5000	5000	520	5000
TCC1xxx18Xxx	mm	6000	5000	520	5650
TCC1xxx20Xxx	mm	7000	5000	520	6650

## Installation Data

### ANTI VIBRATION MOUNTING (OPTIONAL)

#### Spring Type

Each mount is coloured to indicate the different loads, refer to instructions supplied for correct allocation.

#### Dimensions

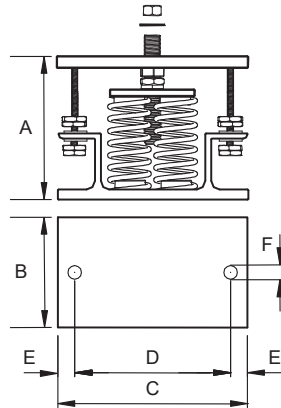

	A(1)	B	C	D	E	FØ
mm	180	130	225	186	20	16

(1) Unloaded dimension

#### Components

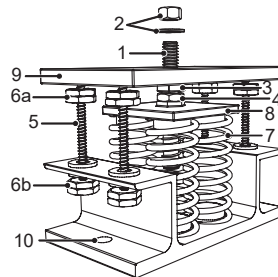

- 1 Locating Screw
- 2 Retaining Nut & Washer
- 3 Levelling Screw
- 4 Levelling Lock Nut
- 5 Retaining Studs
- 6a Upper Retaining Nuts
- 6b Lower Retaining Nuts
- 7 Spring assembly
- 8 Pressure Plate
- 9 Top Plate
- 10 Bolting-down holes

#### Installation

- 1 Locate and secure mount using bolting down holes (10) in base plate.
- 2 Ensure mounts are located in line with the unit base.
- 3 If applicable, remove compressor enclosure covers to allow access to mount fixing holes in the unit base.
- 4 Lock the upper retaining nuts (6a) to the underside of the top plate (9) before a load is applied.
- 5 Remove retaining nut and washer (2), lower the unit onto the mounts and replace retaining nut and washer.
- 6 Beginning with the mount with the largest deflection, adjust the height of each mount using the levelling screw (3).

**CAUTION** **Mountings must be adjusted incrementally in turn. Do not fully adjust 1 mount at a time as this may overload and damage springs.**

- 7 When all mounts are level, lock each into place using the levelling lock nut (4).
- 8 Lock all retaining nuts (6a and 6b) to the extreme ends of the retaining studs (5).

**CAUTION** **Do not connect any services until all anti vibration mounts have been fully adjusted.**

#### Pad Type

#### Components/Installation

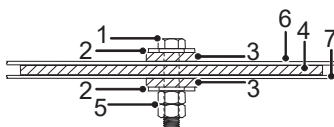

- 1 M16 Bolt (Not Supplied)
- 2 Washer (Not Supplied)
- 3 Fixing Pad 506-063
- 4 A V Pad 506-062
- 5 2 x M16 Nut (Not Supplied)
- 6 Unit Base
- 7 Unit Mounting Plinth

## Installation Data

## ANTI VIBRATION MOUNTING (OPTIONAL) - ALLOCATION

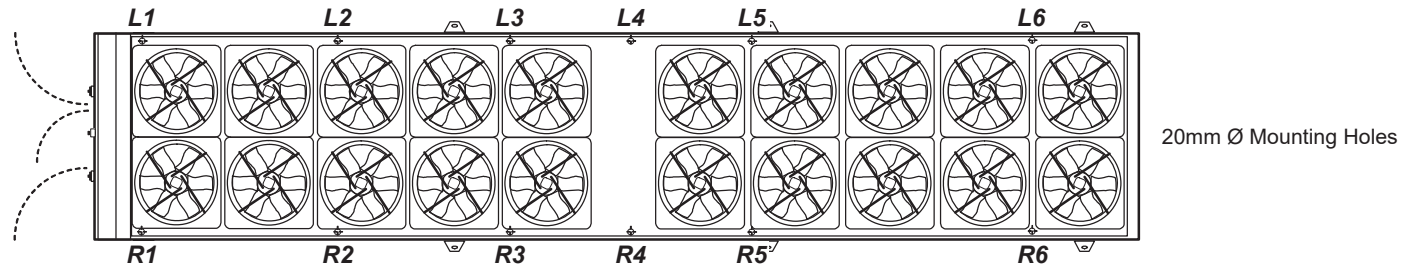

	L1	L2	L3	L4	L5	L6	R1	R2	R3	R4	R5	R6
TTC12B108Xxx	PLAIN	PLAIN	PLAIN	ORANGE	-	-	PLAIN	ORANGE	ORANGE	BLACK	-	-
TTC12B110Xxx	PLAIN	PLAIN	PLAIN	ORANGE	-	-	PLAIN	ORANGE	PLAIN	ORANGE	-	-
TTC12B112Xxx	ORANGE	ORANGE	ORANGE	PLAIN	RED	-	ORANGE	ORANGE	ORANGE	ORANGE	RED	-
TTC12B114Xxx	ORANGE	PLAIN	ORANGE	PLAIN	BLACK	-	ORANGE	ORANGE	ORANGE	ORANGE	BLACK	-
TTC12B116Xxx	PLAIN	PLAIN	PLAIN	PLAIN	BLACK	-	PLAIN	ORANGE	ORANGE	PLAIN	BLACK	-
TTC12B118Xxx	PLAIN	PLAIN	PLAIN	PLAIN	BLACK	-	PLAIN	PLAIN	ORANGE	PLAIN	BLACK	-
TTC12B120Xxx	ORANGE	BLACK	PLAIN	ORANGE	PLAIN	BLACK	ORANGE	BLACK	ORANGE	ORANGE	ORANGE	BLACK
TTC12B208Xxx	PLAIN	PLAIN	PLAIN	ORANGE	-	-	PLAIN	ORANGE	ORANGE	BLACK	-	-
TTC12B210Xxx	PLAIN	PLAIN	PLAIN	ORANGE	-	-	PLAIN	ORANGE	PLAIN	ORANGE	-	-
TTC12B212Xxx	ORANGE	ORANGE	ORANGE	PLAIN	RED	-	ORANGE	ORANGE	ORANGE	ORANGE	RED	-
TTC12B214Xxx	ORANGE	PLAIN	ORANGE	PLAIN	BLACK	-	ORANGE	ORANGE	ORANGE	ORANGE	BLACK	-
TTC12B216Xxx	PLAIN	PLAIN	PLAIN	PLAIN	BLACK	-	PLAIN	ORANGE	ORANGE	PLAIN	BLACK	-
TTC12B218Xxx	PLAIN	PLAIN	PLAIN	PLAIN	BLACK	-	PLAIN	PLAIN	ORANGE	PLAIN	BLACK	-
TTC12B220Xxx	ORANGE	BLACK	PLAIN	ORANGE	PLAIN	BLACK	ORANGE	BLACK	ORANGE	ORANGE	ORANGE	BLACK
TTC12C110Xxx	PLAIN	PLAIN	PLAIN	ORANGE	-	-	PLAIN	PLAIN	PLAIN	ORANGE	-	-
TTC12C112Xxx	ORANGE	ORANGE	ORANGE	PLAIN	RED	-	ORANGE	ORANGE	ORANGE	ORANGE	RED	-
TTC12C114Xxx	ORANGE	PLAIN	PLAIN	PLAIN	BLACK	-	ORANGE	ORANGE	ORANGE	ORANGE	BLACK	-
TTC12C116Xxx	PLAIN	PLAIN	PLAIN	PLAIN	BLACK	-	PLAIN	PLAIN	ORANGE	PLAIN	BLACK	-
TTC12C118Xxx	PLAIN	PLAIN	PLAIN	PLAIN	BLACK	-	PLAIN	PLAIN	PLAIN	PLAIN	BLACK	-
TTC12C120Xxx	ORANGE	BLACK	PLAIN	PLAIN	PLAIN	BLACK	ORANGE	BLACK	ORANGE	ORANGE	ORANGE	BLACK
TTC12D110Xxx	PLAIN	PLAIN	PLAIN	ORANGE	-	-	PLAIN	PLAIN	PLAIN	ORANGE	-	-
TTC12D112Xxx	ORANGE	PLAIN	ORANGE	PLAIN	RED	-	ORANGE	ORANGE	ORANGE	ORANGE	RED	-
TTC12D114Xxx	ORANGE	PLAIN	PLAIN	PLAIN	BLACK	-	ORANGE	ORANGE	ORANGE	ORANGE	BLACK	-
TTC12D116Xxx	ORANGE	PLAIN	PLAIN	PLAIN	BLACK	-	ORANGE	PLAIN	ORANGE	PLAIN	BLACK	-
TTC12D118Xxx	PLAIN	PLAIN	PLAIN	PLAIN	BLACK	-	PLAIN	PLAIN	PLAIN	PLAIN	BLACK	-
TTC12D120Xxx	ORANGE	BLACK	PLAIN	PLAIN	PLAIN	BLACK	ORANGE	BLACK	PLAIN	ORANGE	PLAIN	BLACK
TTC12D210Xxx	PLAIN	PLAIN	PLAIN	ORANGE	-	-	PLAIN	PLAIN	PLAIN	ORANGE	-	-
TTC12D212Xxx	ORANGE	ORANGE	ORANGE	PLAIN	RED	-	ORANGE	ORANGE	ORANGE	ORANGE	RED	-
TTC12D214Xxx	ORANGE	PLAIN	PLAIN	PLAIN	BLACK	-	ORANGE	ORANGE	ORANGE	ORANGE	BLACK	-
TTC12D216Xxx	ORANGE	PLAIN	PLAIN	PLAIN	BLACK	-	ORANGE	PLAIN	ORANGE	PLAIN	BLACK	-
TTC12D218Xxx	PLAIN	PLAIN	PLAIN	PLAIN	BLACK	-	PLAIN	PLAIN	PLAIN	PLAIN	BLACK	-
TTC12D220Xxx	ORANGE	BLACK	PLAIN	PLAIN	PLAIN	BLACK	ORANGE	BLACK	ORANGE	ORANGE	ORANGE	BLACK



	L1	L2	L3	L4	L5	L6	R1	R2	R3	R4	R5	R6
TTC13B112Xxx	PLAIN	PLAIN	PLAIN	PLAIN	BLACK	-	PLAIN	ORANGE	ORANGE	ORANGE	BLACK	-
TTC13B114Xxx	PLAIN	PLAIN	PLAIN	PLAIN	BLACK	-	PLAIN	PLAIN	ORANGE	ORANGE	BLACK	-
TTC13B116Xxx	PLAIN	PLAIN	PLAIN	PLAIN	BLACK	-	PLAIN	PLAIN	PLAIN	PLAIN	BLACK	-
TTC13B118Xxx	PLAIN	PLAIN	PLAIN	PLAIN	BLACK	-	PLAIN	PLAIN	PLAIN	PLAIN	BLACK	-
TTC13B120Xxx	PLAIN	ORANGE	PLAIN	PLAIN	PLAIN	BLACK	PLAIN	BLACK	ORANGE	ORANGE	ORANGE	BLACK
TTC13B212Xxx	PLAIN	PLAIN	PLAIN	PLAIN	BLACK	-	PLAIN	ORANGE	ORANGE	ORANGE	BLACK	-
TTC13B214Xxx	PLAIN	PLAIN	PLAIN	PLAIN	BLACK	-	PLAIN	PLAIN	ORANGE	ORANGE	BLACK	-
TTC13B216Xxx	PLAIN	PLAIN	PLAIN	PLAIN	BLACK	-	PLAIN	PLAIN	PLAIN	PLAIN	BLACK	-
TTC13B218Xxx	PLAIN	PLAIN	PLAIN	PLAIN	BLACK	-	PLAIN	PLAIN	PLAIN	PLAIN	BLACK	-
TTC13B220Xxx	PLAIN	ORANGE	PLAIN	PLAIN	PLAIN	BLACK	PLAIN	BLACK	ORANGE	ORANGE	ORANGE	BLACK
TTC13C112Xxx	PLAIN	PLAIN	PLAIN	PLAIN	BLACK	-	PLAIN	ORANGE	ORANGE	PLAIN	BLACK	-
TTC13C114Xxx	PLAIN	PLAIN	PLAIN	PLAIN	BLACK	-	PLAIN	PLAIN	ORANGE	PLAIN	BLACK	-
TTC13C116Xxx	PLAIN	PLAIN	PLAIN	PLAIN	BLACK	-	PLAIN	PLAIN	PLAIN	PLAIN	BLACK	-
TTC13C118Xxx	PLAIN	PLAIN	PLAIN	PLAIN	BLACK	-	PLAIN	PLAIN	PLAIN	PLAIN	BLACK	-
TTC13C120Xxx	PLAIN	ORANGE	PLAIN	PLAIN	PLAIN	BLACK	PLAIN	BLACK	PLAIN	ORANGE	PLAIN	BLACK
TTC13D112Xxx	PLAIN	PLAIN	PLAIN	PLAIN	RED	-	PLAIN	ORANGE	ORANGE	PLAIN	RED	-
TTC13D114Xxx	PLAIN	PLAIN	PLAIN	PLAIN	BLACK	-	PLAIN	PLAIN	ORANGE	PLAIN	BLACK	-
TTC13D116Xxx	PLAIN	PLAIN	PLAIN	PLAIN	BLACK	-	PLAIN	PLAIN	PLAIN	PLAIN	BLACK	-
TTC13D118Xxx	PLAIN	PLAIN	PLAIN	PLAIN	BLACK	-	PLAIN	PLAIN	PLAIN	PLAIN	BLACK	-
TTC13D120Xxx	ORANGE	ORANGE	PLAIN	PLAIN	PLAIN	BLACK	ORANGE	BLACK	PLAIN	ORANGE	PLAIN	BLACK
TTC13D212Xxx	PLAIN	PLAIN	PLAIN	PLAIN	RED	-	ORANGE	ORANGE	ORANGE	PLAIN	RED	-
TTC13D214Xxx	PLAIN	PLAIN	PLAIN	PLAIN	BLACK	-	PLAIN	PLAIN	ORANGE	PLAIN	BLACK	-
TTC13D216Xxx	PLAIN	PLAIN	PLAIN	PLAIN	BLACK	-	PLAIN	PLAIN	PLAIN	PLAIN	BLACK	-
TTC13D218Xxx	PLAIN	PLAIN	PLAIN	PLAIN	BLACK	-	PLAIN	PLAIN	PLAIN	PLAIN	BLACK	-
TTC13D220Xxx	ORANGE	ORANGE	PLAIN	PLAIN	PLAIN	BLACK	ORANGE	BLACK	PLAIN	ORANGE	PLAIN	BLACK

TTC14B112Xxx	PLAIN	PLAIN	PLAIN	PLAIN	ORANGE	-	PLAIN	ORANGE	ORANGE	PLAIN	BLACK	-
TTC14B114Xxx	PLAIN	PLAIN	PLAIN	PLAIN	ORANGE	-	PLAIN	PLAIN	PLAIN	PLAIN	BLACK	-
TTC14B116Xxx	PLAIN	PLAIN	PLAIN	PLAIN	ORANGE	-	PLAIN	PLAIN	PLAIN	PLAIN	ORANGE	-
TTC14B118Xxx	YELLOW	YELLOW	PLAIN	YELLOW	ORANGE	-	PLAIN	PLAIN	PLAIN	PLAIN	ORANGE	-
TTC14B120Xxx	PLAIN	ORANGE	PLAIN	PLAIN	PLAIN	ORANGE	PLAIN	BLACK	PLAIN	PLAIN	PLAIN	BLACK
TTC14B212Xxx	PLAIN	PLAIN	PLAIN	PLAIN	ORANGE	-	PLAIN	ORANGE	ORANGE	PLAIN	BLACK	-
TTC14B214Xxx	PLAIN	PLAIN	PLAIN	PLAIN	ORANGE	-	PLAIN	PLAIN	PLAIN	PLAIN	BLACK	-
TTC14B216Xxx	PLAIN	PLAIN	PLAIN	PLAIN	ORANGE	-	PLAIN	PLAIN	PLAIN	PLAIN	ORANGE	-
TTC14B218Xxx	YELLOW	YELLOW	PLAIN	YELLOW	ORANGE	-	PLAIN	PLAIN	PLAIN	PLAIN	ORANGE	-
TTC14B220Xxx	PLAIN	ORANGE	PLAIN	PLAIN	PLAIN	ORANGE	PLAIN	BLACK	PLAIN	PLAIN	PLAIN	BLACK
TTC14C112Xxx	PLAIN	PLAIN	PLAIN	PLAIN	ORANGE	-	PLAIN	ORANGE	ORANGE	PLAIN	BLACK	-
TTC14C114Xxx	PLAIN	PLAIN	PLAIN	PLAIN	ORANGE	-	PLAIN	PLAIN	PLAIN	PLAIN	BLACK	-
TTC14C116Xxx	PLAIN	PLAIN	PLAIN	PLAIN	ORANGE	-	PLAIN	PLAIN	PLAIN	PLAIN	ORANGE	-
TTC14C118Xxx	PLAIN	YELLOW	PLAIN	YELLOW	ORANGE	-	PLAIN	PLAIN	PLAIN	PLAIN	ORANGE	-
TTC14C120Xxx	PLAIN	ORANGE	PLAIN	PLAIN	PLAIN	ORANGE	PLAIN	BLACK	PLAIN	PLAIN	PLAIN	BLACK
TTC14D112Xxx	PLAIN	PLAIN	PLAIN	PLAIN	ORANGE	-	PLAIN	PLAIN	PLAIN	PLAIN	BLACK	-
TTC14D114Xxx	PLAIN	PLAIN	PLAIN	PLAIN	ORANGE	-	PLAIN	PLAIN	PLAIN	PLAIN	BLACK	-
TTC14D116Xxx	PLAIN	YELLOW	PLAIN	PLAIN	ORANGE	-	PLAIN	PLAIN	PLAIN	PLAIN	ORANGE	-
TTC14D118Xxx	PLAIN	YELLOW	PLAIN	YELLOW	ORANGE	-	PLAIN	PLAIN	PLAIN	PLAIN	ORANGE	-
TTC14D120Xxx	PLAIN	ORANGE	PLAIN	PLAIN	PLAIN	ORANGE	PLAIN	BLACK	PLAIN	PLAIN	PLAIN	BLACK
TTC14D212Xxx	PLAIN	PLAIN	PLAIN	PLAIN	ORANGE	-	PLAIN	PLAIN	PLAIN	PLAIN	BLACK	-
TTC14D214Xxx	PLAIN	PLAIN	PLAIN	PLAIN	ORANGE	-	PLAIN	PLAIN	PLAIN	PLAIN	BLACK	-
TTC14D216Xxx	PLAIN	YELLOW	PLAIN	PLAIN	ORANGE	-	PLAIN	PLAIN	PLAIN	PLAIN	ORANGE	-
TTC14D218Xxx	PLAIN	YELLOW	PLAIN	YELLOW	ORANGE	-	PLAIN	PLAIN	PLAIN	PLAIN	ORANGE	-
TTC14D220Xxx	PLAIN	ORANGE	PLAIN	PLAIN	PLAIN	ORANGE	PLAIN	BLACK	PLAIN	PLAIN	PLAIN	BLACK

## Installation Data

### POSITIONING

The installation position should be selected with the following points in mind:

- Position on a stable and even base, levelled to ensure that the compressor operates correctly
- Levelling should be to +/- 5mm
- Where vibration transmission to the building structure is possible, fit spring anti-vibration mounts and flexible water connections
- Observe airflow and maintenance clearances
- Pipework and electrical connections are readily accessible
- Where multiple units are installed, due care should be taken to avoid the discharge air from each unit adversely affecting other units in the vicinity
- Within a side enclosed installation, the fan **MUST** be higher than the enclosing structure
- Increase airflow and maintenance clearances for side-enclosed or multiple unit applications
- Ensure there are no obstructions directly above the fans
- Allow free space above the fans to prevent air recirculation

**CAUTION**  Prior to connecting services, ensure that the equipment is installed and completely level.

### AIRFLOW & MAINTENANCE CLEARANCES

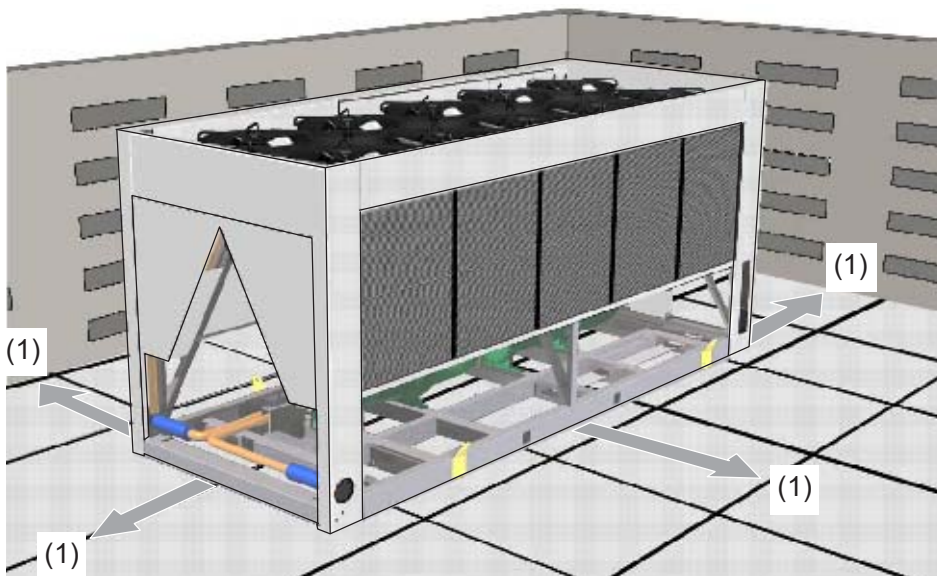

Application	Distance from Overall Base Dimension (1)
Single unit	1300mm
Side-enclosed or multiple units	2600mm

## Installation Data

### WATER SYSTEM

Chilled water pipework and ancillary components must be installed in accordance with:

- National and Local Water supply company standards
- The manufacturer's instructions are followed when fitting ancillary components
- The system liquid is treated to prevent corrosion and algae forming
- In ambients of 0°C and below, where static water can be expected, or when water supply temperatures of +5°C or below is required, the necessary concentration of Glycol or use of an electrical trace heater must be included
- The schematic is referred to as a guide to ancillary recommendations

### CAUTION

The unit water connections are **NOT** designed to support external pipework, pipework **MUST** be supported separately.

### GROOVED & CLAMPED TYPE CONNECTION

#### 1 Place Grooved Ends Together

- Note that an expansion gap of 5mm is shown here

#### 2 Locate Rubber Gasket

- The gasket should be checked for compatability and damage prior to installation
- A thin coat of sealing lubricant should be applied to both the inside and outside mating surfaces
- Slip the gasket fully onto one of the pipe ends, align the second pipe and slide the gasket into place

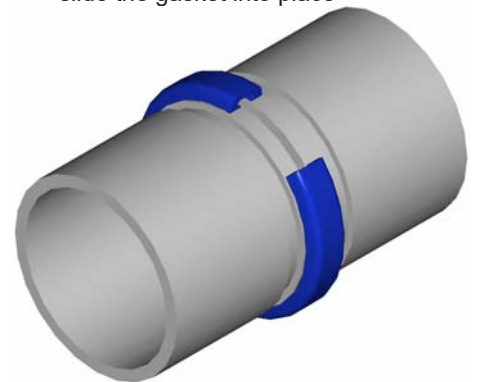
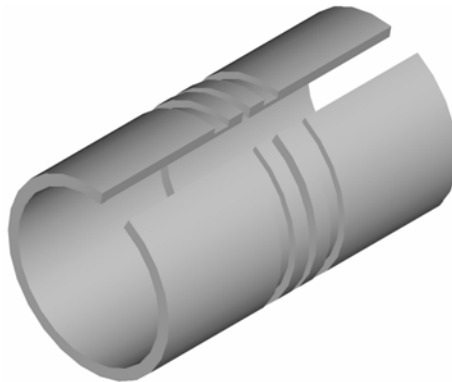

#### 3 Place Clamp over Gasket

- Wrap the 2-halves of the clamp over the gasket
- Ensure the gasket fits snugly within the grooved recess within the inside of the clamp and that the clamp mates correctly

#### 4 Secure Clamp

- Tightend the bolts incrementally and evenly at both sides until a leak free seal is formed
- The gasket should not be visible beneath the clamp when the bolts are properly tightened

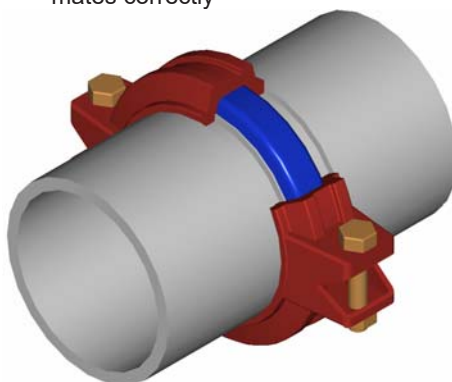

## Installation Data

### STANDARD RECOMMENDED INSTALLATION (Parts Supplied by Others)

#### GENERAL

The following diagram illustrates the minimum component installation requirements. A wide range of optional extras are available to suit various applications, please refer to **Optional Extras**, on page 9.

**CAUTION**  The following installation recommendations should be adhered to. Failure to do this may invalidate the chiller warranty.

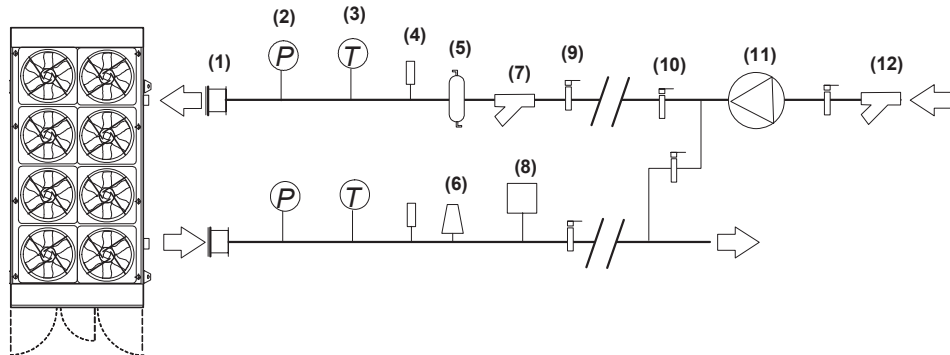

- |                                      |                                    |
|--------------------------------------|------------------------------------|
| (1) Flexible connections             | (7) Strainer (optional extra)      |
| (2) Pressure gauges                  | (8) Flow switch                    |
| (3) Temperature gauges               | (9) Shut off valves                |
| (4) Binder points                    | (10) Bypass circuit (for flushing) |
| (5) De-aerater (optional extra)      | (11) Pump                          |
| (6) Auto air vent (at highest point) | (12) Pump strainer                 |

**CAUTION**  Full design water flow **MUST** be maintained at all times. Variable water volume is **NOT** recommended and will invalidate warranty

The correct operation of the flow proving device is critical if the chiller warranty is to be valid.

Following components are fitted within the chiller unit as standard:

- Temperature Sensors
- Drain Point
- Auto Air Vent

### WATER SYSTEM

#### Component Recommended Requirements

The recommended requirements to allow commissioning to be carried out correctly are:

- The inclusion of Binder Points adjacent to the flow and return connections, to allow temperature and pressure readings
- A flow switch or equivalent, fitted adjacent to the water outlet side of the unit Chiller
- A 20 mesh strainer fitted prior to the evaporator inlet
- A water-flow commissioning valve set fitted to the system
- In multiple chiller installations, 1 commissioning valve set is required per chiller
- Isolating valves should be installed adjacent to all major items of equipment for ease of maintenance
- Balancing valves can be installed if required to aid correct system balancing
- All chilled water pipework must be insulated and vapour sealed to avoid condensation
- If several units are installed in parallel adjacent to each other, reverse return should be applied to avoid unnecessary balancing valves

## Installation Data

### WATER SYSTEM

#### Pump Statement

When installing circulating water pumps or equipment containing them, the following rules should be applied:

- Ensure the system is filled with liquid then vented and the pump primed with water before running the pump, this is required because the pumped liquid cools the pump bearings and mechanical seal faces
- To avoid cavitation the NPSH (Net Positive Suction Head) incorporating a safety margin of 0.5m head must be available at the pump inlet during operation

#### Interlocks & Protection

Always electrically interlock the operation of the chiller with the pump controls and flow proving device for safety reasons.

**CAUTION**  Failure to install safety devices will invalidate the chiller warranty.

**CAUTION**  Do not rely solely on the BMS to protect the chiller against low flow conditions.

An evaporator pump interlock and flow proving device **MUST** be directly wired to the chiller, to *Interconnecting Wiring*, on page 25.

#### Maximum System Operating Pressure

The system can safely be operating at a maximum of 10bar.

#### Pressure Testing

When all the pipework has been connected in the system, proceed as follows:

- Ensure all shut off and control valves are fully open
- Pressurise system to the operating pressure, hold for 1 hour (a gradual fall in pressure shown on the gauge indicates a leak)
- Leaks should be found and repaired and the unit pressure tested for a further hour

When the pressure remains at the operating pressure for 1 hour, the system can be considered leak free.

**CAUTION**  Although a pressure of 1.5 x working pressure is adequate for testing purposes, most local water authorities require 2 x working pressure.

**RECORD**  Record on commissioning sheet provided once completed.

#### Filling

**CAUTION**  The whole system **MUST** be flushed prior to filling to remove debris left in the water pipework by using a flushing bypass as shown to avoid serious damage to the plate evaporator.

- During filling the system should be vented at all high points
- Once the system has been completely vented all vents should be closed
- To prevent air locking in the system it is advisable to fill the systems from the lowest point, ie drain point on pipework
- If auto air vents are used then we strongly recommend an auto pressurisation unit be fitted to the system

## Installation Data

### GLYCOL DATA

For a given percentage of glycol in the system there are correction factors that need to be applied, the following tables can be used as a guide.

**CAUTION**  The source data must be at 100% Water for the correction factors to be valid.

### Ethylene Glycol Nominal Correction Factors

Glycol in System / Freezing Point °C		10% / -4°C	20% / -9°C	30% / -15°C	40% / -23°C
Output (kW)	x	0.98	0.97	0.95	0.93
Compressor Input (kW)		0.99	0.98	0.96	0.95
Water Flow (l/s)		0.99	1.02	1.04	1.07
Pressure Drop (kPa)		1.05	1.20	1.38	1.57

### Propylene Glycol Nominal Correction Factors

Glycol in System / Freezing Point °C		10% / -2°C	20% / -6°C	30% / -12°C	40% / -20°C
Output (kW)	x	0.97	0.95	0.91	0.88
Compressor Input (kW)		0.99	0.98	0.96	0.95
Water Flow (l/s)		0.98	0.97	0.95	0.95
Pressure Drop (kPa)		1.08	1.17	1.31	1.45

### Example:

#### At 100% Water:

Output = 800 kW  
 Compressor Input = 250.5 kW  
 Flow Rate = 38.2  
 Pressure Drop = 37.5 kPa  
 Ambient = 35°C  
 Inlet Fluid Temp. = 7°C  
 Outlet Fluid Temp. = 12°C (5°C ΔT)

#### To 20% Ethylene Glycol:

	100% Water	Multiplier	Corrected Figures
Output (kW)	800.0	x 0.97	776.0 kW
Compressor Input (kW)	250.5	x 0.98	245.5 kW
Water Flow (l/s)	38.2	x 1.02	38.9 l/s
Pressure Drop (kPa)	37.5	x 1.20	45.0 kPa

**CAUTION**  Waste glycol needs to be handled responsibly, recycled or turned over to professional personnel for correct disposal. Most anti-freeze manufacturers recommend that used anti-freeze be collected and disposed according to Local Legislation. Waste glycol should NOT be drained onto the ground, rainwater drainage system or natural waters.

If the glycol contains heavy metals or other contaminants from gas or oil, the level of hazard posed by the glycol is increased and could be characterised as hazardous waste.

#### STEPS IF GLYCOL IS RELEASED/SPILLED

Small spill - soak up with absorbent material.

Large spill - contain spill and pump to suitable container for disposal.

# Installation Data

## WATERSIDE PRESSURE DROP (KPA)

**CAUTION**  Full design water flow **MUST** be maintained at all times. Variable water volume is **NOT** recommended and will invalidate warranty.

Refer to the unit nomenclature to identify the Evaporator Code TTC1x"XX"xxXxx.

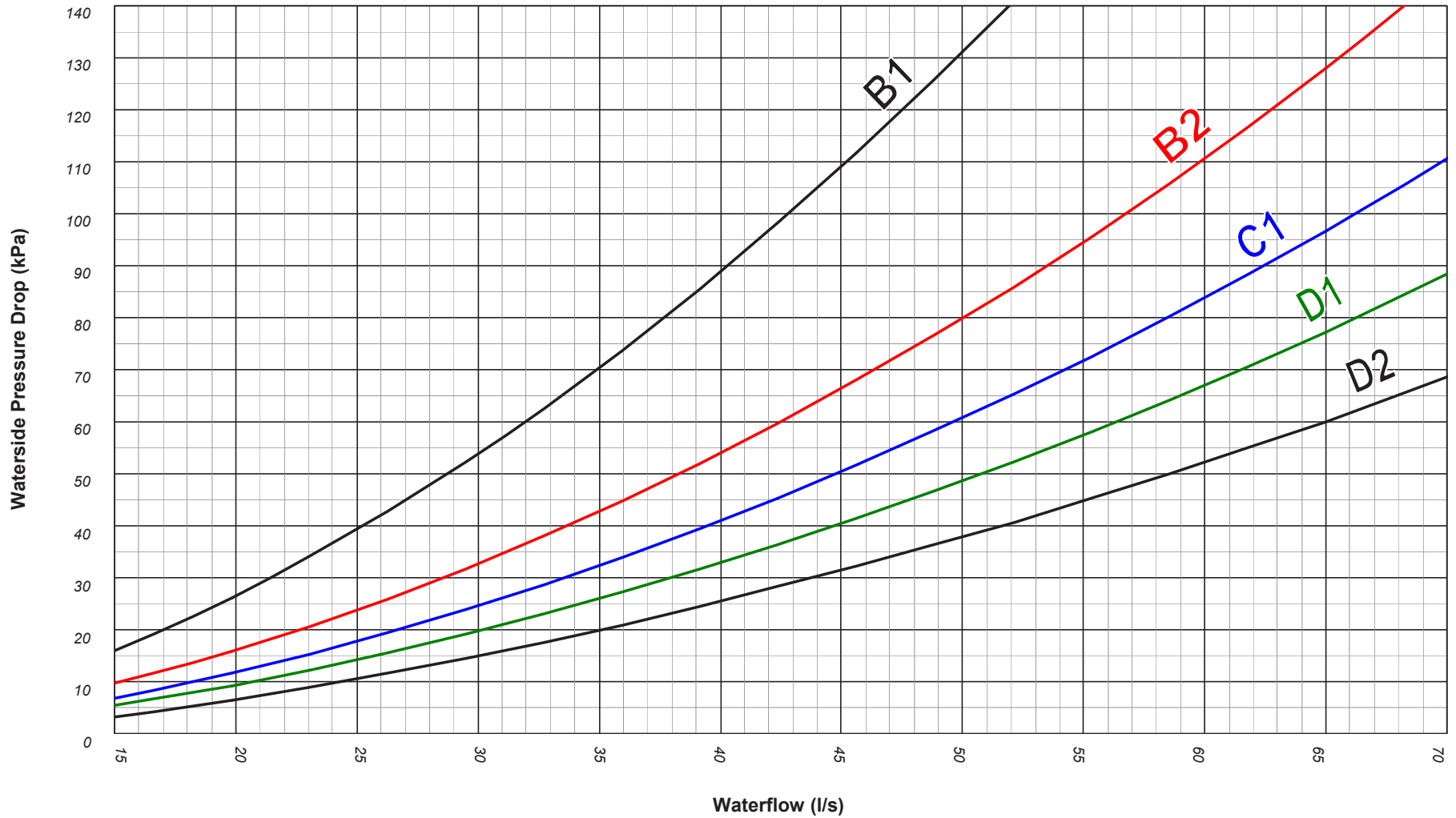

## Installation Data

### ELECTRICAL

<b>IMPORTANT</b>		<p>Please refer to the electrical wiring diagrams provided for installation.</p> <p><b>ALL work MUST be carried out by technically trained competent personnel.</b></p> <p>The equipment contains live electrical and moving parts, <b>ISOLATE</b> prior to maintenance or repair work.</p> <p>The unit isolators <b>DO NOT</b> isolate the incoming mains supply, but isolate the individual electrical panels. Isolate <b>REMOTELY</b> the mains incoming supply to the <b>BUSBAR</b> chamber prior to maintenance or repair work.</p>
------------------	---	--

### General

- As standard the equipment is designed for 400V, 3 phase, 3 wire 50Hz and a separate permanent 230V, 1 phase, 50Hz supply, to all relevant IEE regulations, British standards and IEC requirements
- The control voltage to the interlocks is 24V, always size the low voltage interlock and protection cabling for a maximum voltage drop of 2V
- Avoid large voltage drops on cable runs, particularly low voltage wiring

**CAUTION**  The Emergency Stop **MUST NOT** be used to stop the chiller other than in the event of an emergency.

A fused and isolated electrical supply of the appropriate phase, frequency and voltage should be installed.

Wires should be capable of carrying the maximum load current under non-fault conditions at the stipulated voltage.

A separately fused, locally isolated, permanent single phase and neutral supply **MUST BE FITTED** for the compressor oil heater, evaporator trace heating and control circuits, **FAILURE to do so will INVALIDATE WARRANTY.**

Ensure correct phase rotation.

Unit controls supply is supported by an on board UPS to ensure control operation is maintained in the event of a system shut down in a power failure situation. Power will be maintained until mains power is reinstated for a maximum period of 10 minutes.

Refer also to *Interlocks & Protection*, on page 21.



## Installation Data

### ELECTRICAL DATA

		All Models
<b>Unit Data</b>		<p><i>Refer to Electrical Wiring Diagrams provided</i>  <i>Refer to Electrical Wiring Diagrams provided</i></p> <p>400 V 3 PH 50 Hz                      Direct to Bus Bar                      230 V 1 PH 50 Hz                      16                      4mm<sup>2</sup> Terminal                      24V / 230VAC</p>
Nominal Run Amps	A	
Rec Mains Fuse Size	A	
Mains Supply	VAC	
Max Mains Incoming Cable Size	mm <sup>2</sup>	
Independent Permanent Supply	VAC	
Rec Permanent Fuse Size	A	
Max Permanent Incoming Cable Size	mm <sup>2</sup>	
Control Circuit	VAC	24V / 230VAC
<b>Evaporator</b>		
Immersion Heater Rating	W	100
<b>External Trace Heating</b>		
Available (fitted by others)	W	500
<b>Condenser Fan - Per Fan</b>		
Full Load Amps	A	3.4
Motor Size	kW	2.2
<b>Compressor - Per Compressor</b>		
Motor Size	kW	85
Nominal Run Amps	(1) A	135
Start Amps	A	2
Type Of Start		Digital Electronic Soft Start

(1) Based on Full Load Condition @ 35°C Ambient.

### INTERCONNECTING WIRING

TURBOCHILL		L1	○	←	Mains incoming supply 400V/3PH/50Hz
		L2	○	←	
		L3	○	←	
		E	○	←	
		L4	○	←	Separate Permanent Supply 230V/1PH/50Hz
		N1	○	←	
		E	○	←	
		11	○	→	External Trace Heating Connections 230V/500W max
		N	○	→	
		502	○	→	(1) Remote Pump Interlock 24VAC
		507	○	←	
		502	○	→	(1) Evaporator Pump Water Flow Switch 24VAC
		505	○	←	
		502	○	→	Unit Remote On/Off 24VAC
		504	○	←	
		502	○	→	Setback Setpoint Temperature switch
		506	○	←	
		581	○	←	Non-Critical Alarm
		580	○	→	
		582	○	→	
		591	○	←	Critical Alarm
		590	○	→	
		592	○	→	
		RX-/Tx-	○	←	iRE Lan Network Connections (Inward connection)
	RX+/Tx+	○	←		
	GND	○	←		
	RX-/Tx-	○	→	iRE Lan Network Connections (Outward connection)	
	RX+/Tx+	○	→		
	GND	○	→		

**CAUTION**  (1) MUST be directly wired to the chiller to validate warranty.

Notes:

Notes:



**Head Office:**

**Airedale International Air Conditioning Ltd**  
Leeds Road  
Rawdon  
Leeds LS19 6JY  
United Kingdom

**Tel: +44 (0) 113 239 1000**  
**Fax: +44 (0) 113 250 7219**

**e-mail: [enquiries@airedale.com](mailto:enquiries@airedale.com)**  
**website: [www.airedale.com](http://www.airedale.com)**



<b>PART NO:</b>	<b>ISSUE</b>
<b>6703052 (IM E)</b>	<b>05/2008</b>