

BLU

MONOBLOCK 270 - 17000 kW

DUOBLOCK 350 - 25000 kW



A complete range of burners for all fuels
Полный модельный ряд горелок для всех видов топлива
Une gamme complète de brûleurs pour tous les combustibles
Una gama completa de quemadores para todos los combustibles

MONOBLOCK 20 - 17000 kW
DUOBLOCK 350 - 25000 kW

Select your application - Выберите приложение
Sélectionnez votre application - Seleccione su aplicación



MODEL SIZE

BLU 1200.1	1200 kW
------------	---------

EMISSIONS

LN - Low NOx	Low NOx Class 3 - GAS EN676 (<80 mg/kWh)
-	Standard Class 2 - GAS EN676 (<120 mg/kWh)

OPERATION TYPE

PAB	2 stages soft start
PR	2 stages progressive mechanical
E	2 stages modulating electronic

HEAD TYPE

TC	Short head
TL	Long head

FUEL

GN	Gas natural
LPG	Liquid gas
BIOGAS	Biogas

ТИПОРАЗМЕР

BLU 1200.1	1200 кВт
------------	----------

ВЫБРОСЫ

LN - Low NOx	Low NOx класс 3 - газ по EN676 (<80 мг/кВт·ч)
-	Стандарт класс 2 - газ по EN676 (<120 мг/кВт·ч)

ВИД РЕГУЛИРОВАНИЯ

PAB	двухступенчатая плавный пуск
PR	плавно-двухступенчатая с механическим регулированием
E	двухступенчатая модулируемая с электронным регулированием

ТИП ГОЛОВЫ

TC	Короткая огневая головка
TL	Длинная огневая головка

ВИД ТОПЛИВА

GN	природный газ
LPG	сжиженный газ
BIOGAS	биогаз

MAIN FEATURES

- All burners feature high versatility on different types of domestic, commercial and industrial application
- Aluminium casing up to BLU 2000.1 and steel casing from 3000.1 with electrical panel IP40 on board
- Adjustable combustion head for fine-tune regulation and matching with different combustion chamber
- Modulating version with PID system controller with digital set point display and real time value
- Separate gas train (available for different inlet gas pressure) easy to assemble into the burner
- Configured and special version on request for selected type of applications and fuel characteristics
- DUOBLOCK and ELECTRONIC versions are available on request for selected output to match main boilers and industry applications

ХАРАКТЕРИСТИКИ

- Все горелки отличаются универсальностью и могут использоваться как на гражданских, так и промышленных объектах
- Алюминиевый корпус для моделей вплоть до BLU 2000.1 и стальной, начиная с модели 3000.1, со встроенной панелью управления
- Регулируемая огневая головка упрощает регулировку горелки для работы с различными камерами сгорания
- Модели с модуляцией мощности оборудуются PID-регулятором с цифровым дисплеем, на котором отображаются фактические значения параметров. Имеется возможность изменения значений уставки
- Отдельная газовая рампа (подбираемая в зависимости от входного давления газа) легко монтируется на корпус горелки
- Специальное исполнение и конфигурация по запросу для определенных видов применения и характеристик топлива
- Двухблочное исполнение DUOBLOCK и электронное управление доступны по запросу для определенных значений выходной мощности с целью обеспечения соответствия условиям работы в составе котла или промышленной установки.



BLU 700.1 PAB



BLU 2000.1 PAB



TAILLE DU MODÈLE

BLU 1200.1	1200 kW
------------	---------

EMISSIONS

LN - Low NOx	Bas NOx Classe 3 - GAZ EN676 (<80 mg/kWh)
-	Standard Classe 2 - GAZ EN676 (<120 mg/kWh)

TYPE DE FONCTIONNEMENT

PAB	2 allures démarrage à débit réduit
PR	2 allures progressives, mécanique
E	2 allures progressives, électronique

TYPE DE TÊTE

TC	Tête courte
TL	Tête longue

COMBUSTIBLE

GN	Gaz naturel
LPG	Gaz de pétrole liquéfié
BIOGAS	Biogaz

MODELO

BLU 1200.1	1200 kW
------------	---------

EMISIONES

LN - Low NOx	Bajo NOx Clase 3 - GAS EN676 (<80 mg/kWh)
-	Estándar Clase 2 - GAS EN676 (<120 mg/kWh)

TIPO DE FUNCIONAMIENTO

PAB	2 etapas puesta en marcha suave
PR	2 etapas progresivo mecánico
E	2 etapas modulante electrónico

TIPO DE CABEZA

TC	Cabeza corta
TL	Cabeza larga

COMBUSTIBLE

GN	Gaz natural
LPG	Gas líquido
BIOGAS	Biogaz

CARACTERISTIQUES

- Toute la gamme se caractérise par sa grande adaptabilité dans les applications domestique et industrielles
- Corps en aluminium jusqu'au BLU 2000.1, corps en acier à partir du 3000.1; avec tableau de bord intégré au brûleur
- Tête de combustion réglable pour garantir de meilleurs accouplements sur différentes chambres de combustion
- Versions modulantes avec thermorégulateur PID et affichage numérique qui donne la valeur réelle et permet de régler le point de consigne
- Rampe gaz séparée (disponible pour différentes pressions de gaz) de montage simple
- Versions configurées et spéciales sur demande selon le type d'application et les caractéristiques du combustible
- Les versions DUOBLOCK et ELECTRONIQUE sont disponibles sur demande pour des puissances choisies en combinaison avec les grosses chaudières et les applications industrielles

CARACTERÍSTICAS

- Toda la gama se caracteriza por su gran versatilidad en la aplicación para instalaciones domésticas, comerciales y industriales
- Cuerpo de aleación de aluminio hasta el modelo BLU 2000.1 y en fundición de acero a partir del modelo 3000.1, con el cuadro eléctrico incorporado en el quemador
- Cabeza de combustión regulable para garantizar el mejor acoplamiento en las diferentes cámaras de combustión
- Versión modulante con termoregulador PID con display digital que visualiza el valor real y permite la regulación del set point
- Rampa de gas separada (disponible para diferentes presiones de gas) y de fácil instalación
- Configurado y versión especial a solicitud para aplicaciones selectas y características de combustibles
- Versiones DUOBLOCK y ELECTRONICA están disponibles a solicitud para ciertas potencias para hacer juego con calderas principales y aplicaciones industriales

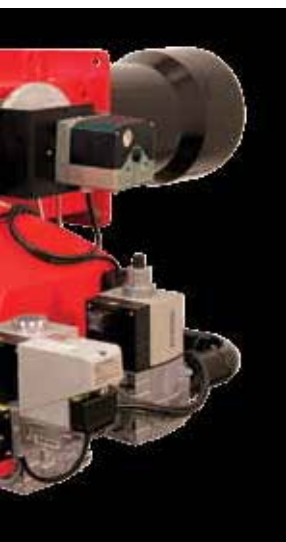

BLU 6000.1 PR



BLU 8000.1 PR

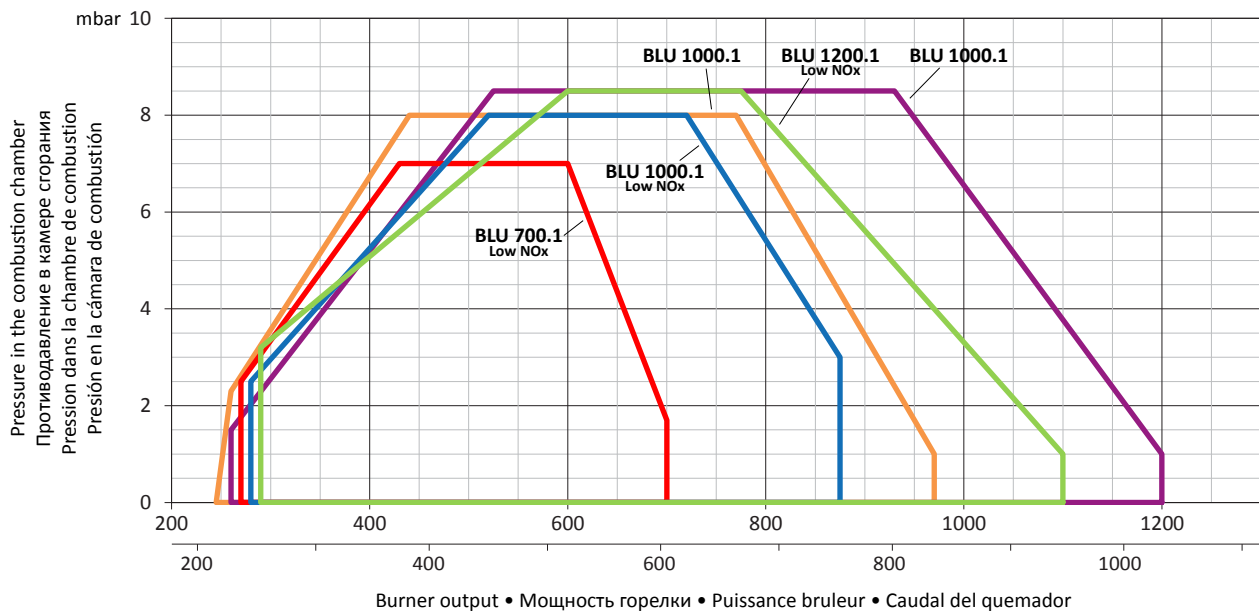

EN 676	
Classe Класс	NOx mg/kWh мг/кВтч
1	170
2	120
3	80

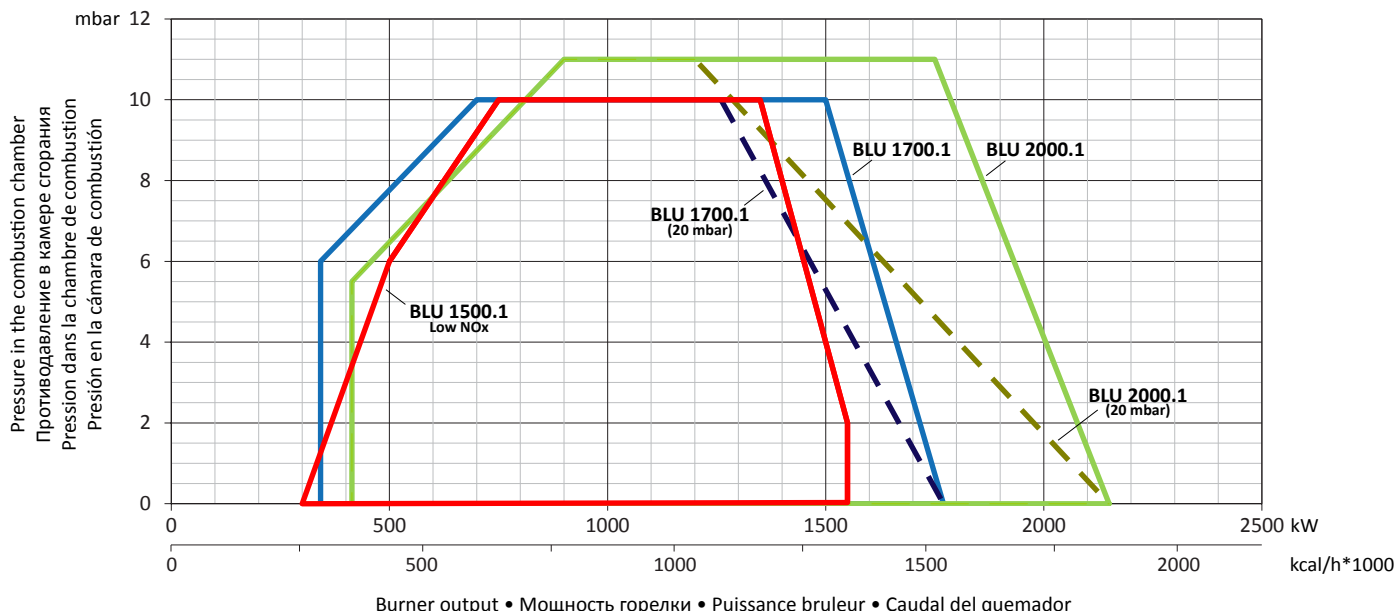

TECHNICAL DATA • ТЕХНИЧЕСКИЕ ДАННЫЕ • DONNEES TECHNIQUES • DATOS TECNICOS

	Output Тепловая мощность Puissance calorifique Potencia térmica MIN / МИН		Output Тепловая мощность Puissance calorifique Potencia térmica MAX / МАКС		Gas pressure Давление газа Pression gaz Presión gas kg/h кг/ч	Power supply Электроснабжение Tension Tensión electrica V В	Motor Мощность Двигателя Moteur Motor W Вт	Class Класс Classe Clase NOx	Operation Модификация Fonctionnement Funcionamiento
	kW кВт	kcal/h*1000 ккал/ч*1000	kW кВт	kcal/h*1000 ккал/ч*1000					
BLU 700.1 Low NOx	270	232	700	602	15 ÷ 500	230/400	740	3	P AB - PR
BLU 1000.1 Low NOx	280	241	875	753	30 ÷ 500	230/400	1100	3	P AB - PR
BLU 1000.1	245	211	970	836	25 ÷ 500	230/400	1100	2	P AB - PR
BLU 1200.1 Low NOx	290	249	1100	946	20 ÷ 600	230/400	2200	3	P AB - PR
BLU 1200.1	260	224	1200	1035	25 ÷ 600	230/400	2200	2	P AB - PR
BLU 1500.1 Low NOx	300	259	1550	1336	30 ÷ 700	230/400	3000	3	P AB - PR
BLU 1700.1	342	295	1770	1526	20 ÷ 700	230/400	3000	2	P AB - PR
BLU 2000.1	414	357	2150	1854	23 ÷ 700	230/400	4000	2	P AB - PR

• FUEL:
natural gas (L.C.V. 8570 kcal/Nm³),
LPG (L.C.V. 22260 kcal/Nm³)

• ВИД ТОПЛИВА:
природный газ (нижн. теплотворная способность 8570 ккал/Нм³),
сжиженный газ (нижн. теплотворная способность 22260 ккал/Нм³)

• COMBUSTIBLE:
gaz naturel (L.C.V. 8570 kcal/Nm³),
GPL (L.C.V. 22260 kcal/Nm³)

• COMBUSTIBLE:
gas natural (L.C.V. 8570 kcal/Nm³),
GPL (L.C.V. 22260 kcal/Nm³)

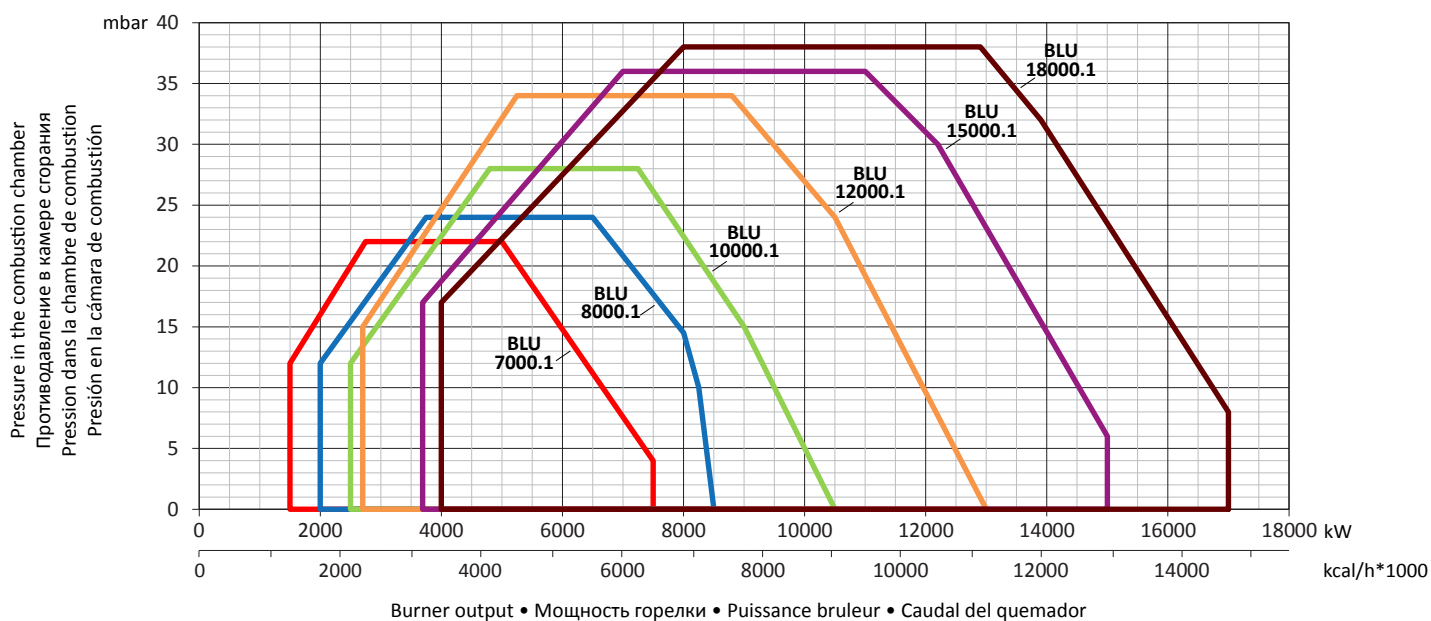
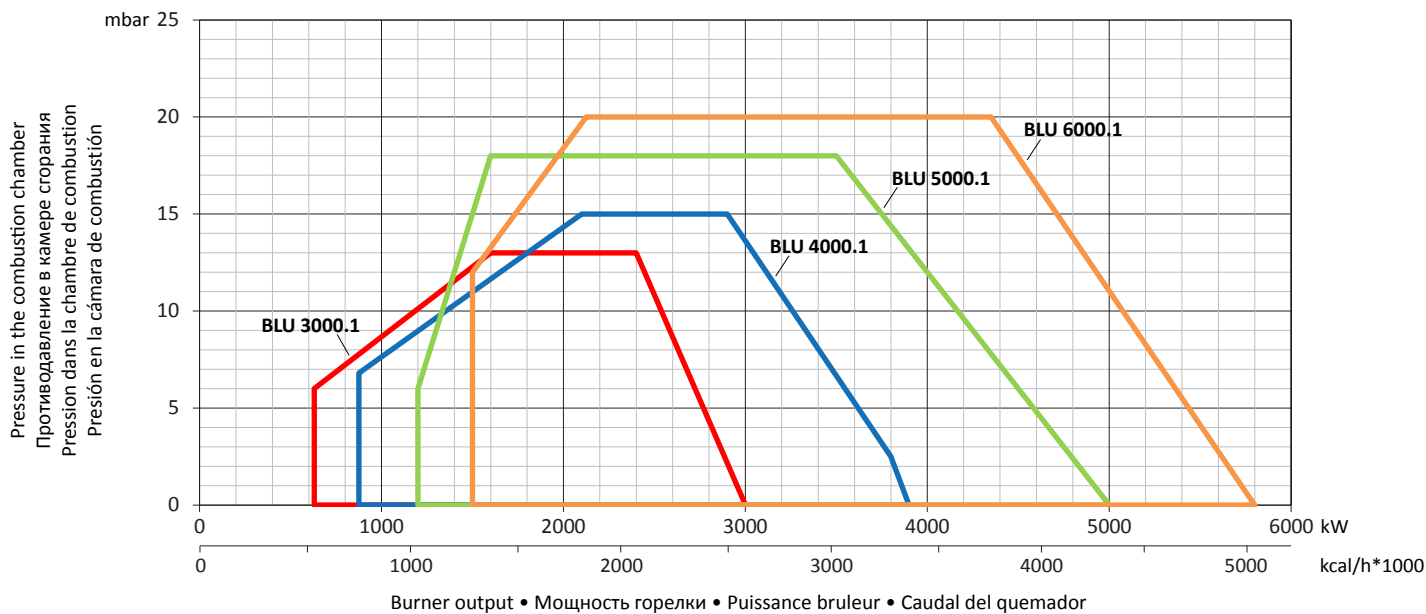

TECHNICAL DATA • ТЕХНИЧЕСКИЕ ДАННЫЕ • DONNEES TECHNIQUES • DATOS TECNICOS

	Output Тепловая мощность Puissance calorifique Potencia térmica MIN / МИН		Output Тепловая мощность Puissance calorifique Potencia térmica MAX / МАКС		Gas pressure Давление газа Presión gas Presión gas MAX / МАКС	Power supply Электропитание Tension Tensión electrica	Motor Мощность Двигателя Moteur Motor	Class Класс Classe Clase	Operation Модификация Funcionamiento
	kW кВт	kcal/h*1000 ккал/ч*1000	kW кВт	kcal/h*1000 ккал/ч*1000	kg/h кг/ч	V В	kW кВт	NOx	
BLU 3000.1	630	543	3000	2586	22 ÷ 700	230/400	5,5	2	PR
BLU 4000.1	875	754	3900	3362	30 ÷ 700	230/400	7,5	2	PR
BLU 5000.1	1200	1035	5000	4310	35 ÷ 700	230/400	11	2	PR
BLU 6000.1	1500	1290	5800	5000	50 ÷ 700	230/400	15	2	PR
BLU 7000.1	1500	1290	7500	6465	60 ÷ 700	230/400	15	2	PR
BLU 8000.1	2000	1724	8500	7328	85 ÷ 700	230/400	18,5	2	PR
BLU 10000.1	2500	2155	10500	9052	115 ÷ 700	230/400	22	2	PR
BLU 12000.1	2700	2328	13000	11207	160 ÷ 700	230/400	37	2	PR
BLU 15000.1	3690	3181	15000	12931	125 ÷ 700	230/400	45	2	PR
BLU 18000.1	4000	3448	17000	14655	175 ÷ 700	230/400	55	2	PR

• FUEL:
natural gas (L.C.V. 8570 kcal/Nm³),
LPG (L.C.V. 22260 kcal/Nm³)

• ВИД ТОПЛИВА:
природный газ (нижн. теплотворная способность 8570 ккал/Нм³),
сжиженный газ (нижн. теплотворная способность 22260 ккал/Нм³)

• COMBUSTIBLE:
gaz naturel (L.C.V. 8570 kcal/Nm³),
GPL (L.C.V. 22260 kcal/Nm³)

• COMBUSTIBLE:
gas natural (L.C.V. 8570 kcal/Nm³),
GPL (L.C.V. 22260 kcal/Nm³)

- **BBCH:** Burner body with combustion head → TC short head and TL long head
- **SILENCER:** included by default from BLU 3000.1 and optional on smaller output KITSIL-...
- **GT:** Gas train separate → EN676 or Export configuration
- **GTCP:** Connection pipe between burner and gas train starting from model 1500.1
- **GAS GOVERNOR & FILTER or FILTER** → EN676 or Export configuration
- **KITTC-....:** Tightness control kit to be included over 1200 kW according to EN676
- **KIT & ACS** can be added according to local rules installation

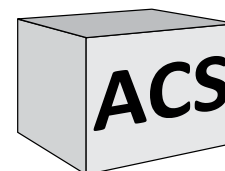
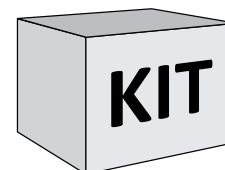
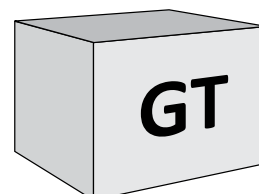
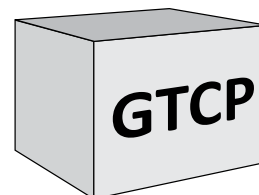
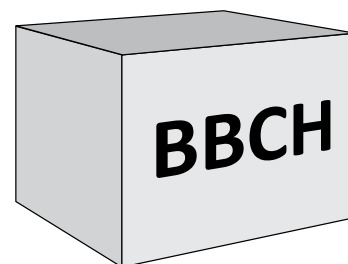

- **BBCH:** Тело горелки с пламенной головой → TC короткая голова и TL длинная голова
- **ШУМОГЛУШИТЕЛЬ:** по умолчанию включен в комплект начиная от BLU 3000.1 для меньшей мощности по желанию KITSIL-...
- **GT:** отдельная газовая рампа → согласно EN676 или на экспорт
- **GTCP:** соединительный патрубок между горелкой и газовой рампой начиная от типоразмера 1500.1
- **СТАБИЛИЗАТОР ДАВЛЕНИЯ ГАЗА + ФИЛЬТР или ФИЛЬТР** → согласно EN676 или на экспорт
- **KITTC-....:** Комплект контроля герметичности обязателен для мощностей более 1200 кВт согласно EN676
- **KIT & ACS** может потребоваться в соответствии с местными правилами монтажа

- **BBCH:** Corps du brûleur avec la tête de combustion → TC tête courte et TL tête longue
- **SILENCIEUX:** inclus de série à partir du BLU 3000.1 et en option en-dessous KITSIL-...
- **GT:** Rampe gaz séparée → configuration EN676 ou Export
- **GTCP:** Tube de liaison entre brûleur et rampe gaz dès le modèle 1500.1
- **REGULATEUR GAZ & FILTRE ou FILTRE** → configuration EN676 ou Export
- **KITTC-....:** le contrôle d'étanchéité est nécessaire au-dessus de 1200 kW selon la EN676
- **KIT & ACS** peuvent être ajoutés selon les règles d'installation locales

- **BBCH:** Cuerpo del quemador con cabeza de combustión → TC cabeza corta y TL cabeza larga
- **SILENCIADOR:** Incluido como estándar desde BLU 3000.1 y opcional en potencias menores KITSIL-...
- **GT:** Rampa de Gas separada → EN676 o Configuración de exportación
- **GTCP:** Tubo de conexión entre quemador y rampa de gas a partir del modelo 1500.1
- **REGULADOR DE PRESION & FILTRO o FILTRO** → EN676 o Configuración de exportación
- **KITTC-....:** Kit de control de estanqueidad a ser incluido a partir de 1200 kW de acuerdo a EN676
- **KIT & ACS** pueden ser agregados de acuerdo a las reglas locales de instalación

KIT & ACCESSORIES • КОМПЛЕКТЫ И ПРИНАДЛЕЖНОСТИ • KITS ET ACCESSOIRES • KIT Y ACCESORIOS

Gas governor/filter Стабилизатор давления/Фильтр Régulateur de pression/filtre Regulador de presión/filtro	Tightness control Устройство контроля герметичности Contrôle d'étanchéité Control de estanqueidad	Modulation Kit PID - Регулятор Kit de modulation Kit de modulación	Max pressure switch Реле макс. давления Pressostat maxi Presostato de máxima presión	LPG/GN Transformation Переделка под сжиженный пропан Transformation LPG/GN Transformación a GPL/GN
FGDR - FILTER	KITTC- Model	KITMD-RWF40	KITPRES50	KITLPG-MAXGAS...
Compulsory EN676	Compulsory over 1200 kW	PROBE-...	KITPRES150	KITGN-BLU...

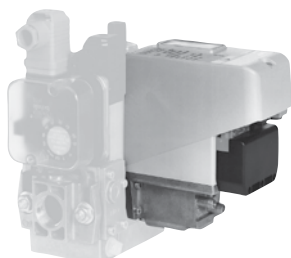

**INVERTER SYSTEM
 O2-CO TRIM CONTROL
 MONITORING APPLICATION**

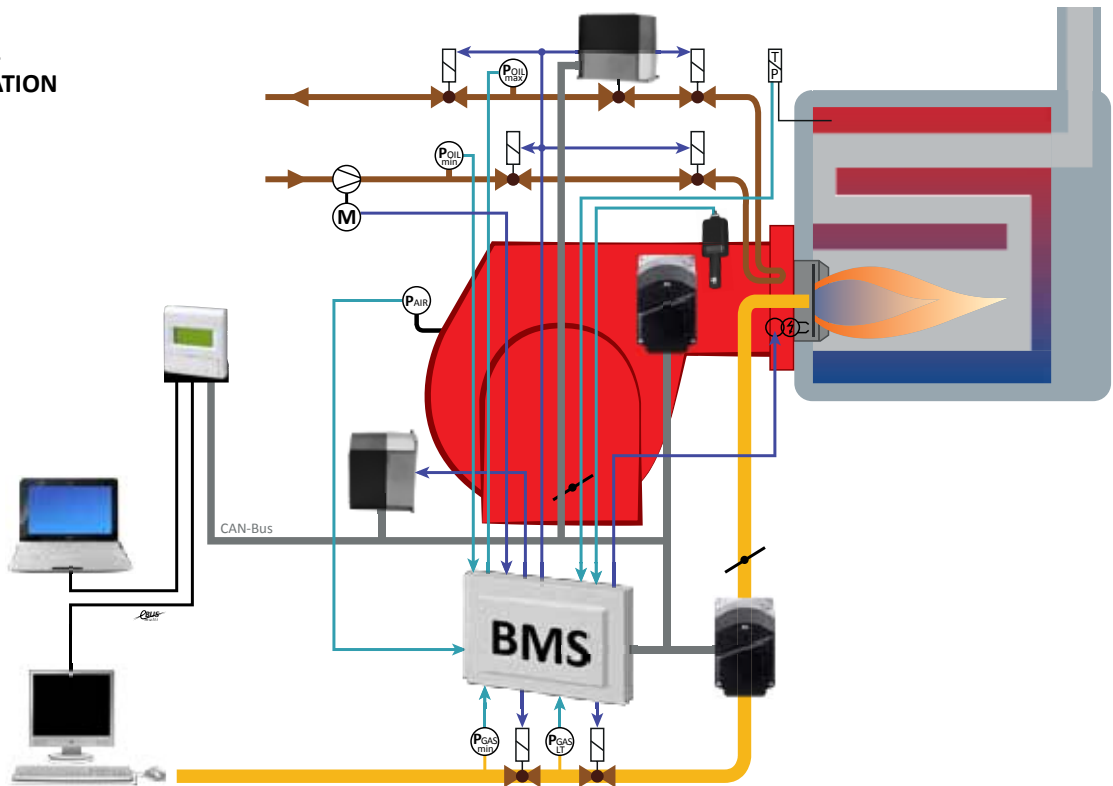

- Burner Management System allows to improve performance and efficiency of modern firing installation. This system is designed to be matched with an extensive range of components such as flame, temperature and pressure sensors, gas valves, variable speed fan motors and oxygen control that can be managed from different bus interfaces
- Система управления горелки используется для улучшения работы и повышения эффективности современных горелочных устройств. Эта система разработана для согласованной работы с широким перечнем компонентов, таких как датчики пламени, температуры и давления, газовые клапаны и электромоторы с переменной скоростью вращения, которые могут управляться через различные шины интерфейсов
- Le Système de gestion permet d'améliorer les performances et le rendement des installations de chauffage modernes. Ce système est fait pour être combiné avec une gamme de composants extensible tels que les sondes de flamme, de température et de pression, les vannes gaz, le variateur de vitesse du ventilateur et de contrôle d'oxygène et peut être géré à partir de différents bus de communication
- El Sistema de Gestión del Quemador permite mejorar el desempeño y eficiencia de las instalaciones con fuentes de calor modernas. Este sistema está diseñado para conectarse con un amplio rango de componentes como son flama, temperatura, sensores de presión, válvulas de gas, ventiladores de velocidad variable y control por oxígeno que pueden ser gestionados desde diferentes interfaces bus

NOISE LEVEL • УРОВЕНЬ ШУМА • NIVEAUX DE BRUIT • NIVEL DE RUIDOS

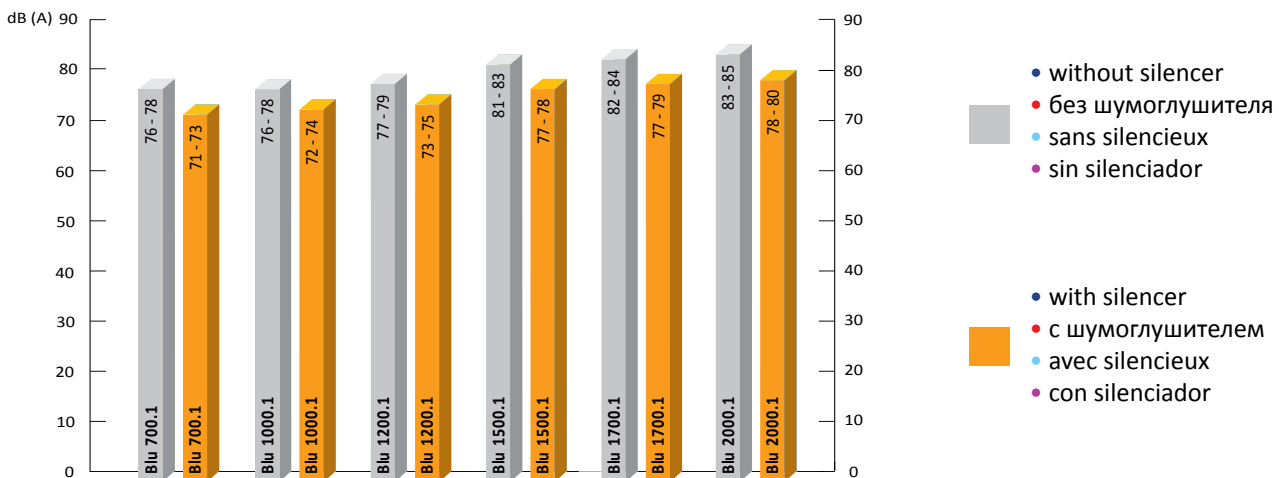

- Data recorded during testing made at a meter distance from the burner
- Данные получены при измерении в лабораторных условиях на расстоянии 1 м от горелки
- Données techniques mesurées à 1 mètre en laboratoire
- Medidas efectuadas en laboratorio a un metro de distancia del quemador

MultiBloc Dungs

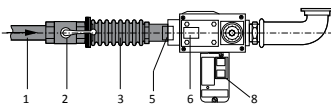

VCS Kromschroder

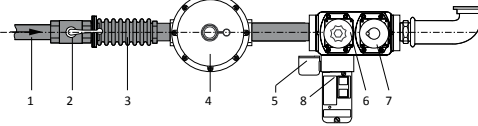

VGD Siemens

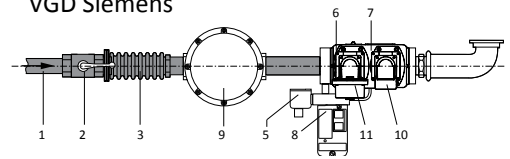

• To be supplied by the installer

• Не входит в стандартную комплектацию

• A fournir par l'installateur

• Accesorios a suministrar por el instalador

1	• Main gas pipe	• Газопровод	• Tuyauterie gaz de réseau	• Tubo de gas
2	• Ball valve	• Шаровый кран	• Vanne d'arrêt	• Valvula de corte
3	• Antivibration coupling	• Антивибрационная вставка	• Manchon antivibration	• Junta antivibración
4	• Gas governor	• Стабилизатор давления	• Régulateur de pression	• Regulador de presión
5	• Gas pressure switch	• Реле давления газа	• Pressostat gaz	• Presostato gas
6	• Safety gas valve	• Предохранительный клапан	• Vanne de sécurité	• Válvula de seguridad
7	• Working gas valve	• Рабочий газ. клапан	• Vanne de réglage	• Válvula de trabajo
8	• Leakage control	• Устройство контроля герметичности	• Dispositif contrôle étanchéité	• Control de estanqueidad
9	• Gas filter	• Газовый фильтр	• Filtre gaz	• Filtro gas
10	• Actuator	• Привод	• Actuateur	• Actuador
11	• Actuator	• Привод	• Actuateur	• Actuador

	GT Gas train	GTCP Gas Train Connection Pipe	GT Designation	Gas governor & filter / filter	Gas pressure [mbar]			KITTC Tightness control EN676	
					LPG min	GN min	max		
BLU 700.1 Low NOx	VCS-125	-	GT-K2-VCS125-RP25-BLU/MULTI	FGDR-RP25	65	175	500	option дополнительно	
	VCS-125	-	GT-K2-VCS125-RP25-BLU/MULTI	FGDR-RP40	-	85	500		
	VCS-240	-	GT-K2-VCS240-RP40-BLU/MULTI	FGDR-RP40	15	30	500		
	VCS-350	-	GT-K2-VCS350-RP50-BLU/MULTI	FGDR-RP50	-	15	500		
	MBDLE410	-	GT-D2-MBDLE410-RP25-BLU/MULTI	-	40	75	360		
	MBDLE412	-	GT-D2-MBDLE412-RP32-BLU/MULTI	included включены	25	45	360		
	MBDLE415	-	GT-D2-MBDLE415-RP40-BLU/MULTI	-	-	25	360		
	MBDLE420	-	GT-D2-MBDLE420-RP50-BLU/MULTI	-	-	17	360		
BLU 1000.1 Low NOx	VCS-125	-	GT-K2-VCS125-RP25-BLU/MULTI	FGDR-RP40	-	170	500	option дополнительно	
	VCS-240	-	GT-K2-VCS240-RP40-BLU/MULTI	FGDR-RP40	24	60	500		
	VCS-350	-	GT-K2-VCS350-RP50-BLU/MULTI	FGDR-RP50	-	30	500		
	MBDLE412	-	GT-D2-MBDLE412-RP32-BLU/MULTI	-	40	75	360		
	MBDLE415	-	GT-D2-MBDLE415-RP40-BLU/MULTI	included включены	25	40	360		
	MBDLE420	-	GT-D2-MBDLE420-RP50-BLU/MULTI	-	-	35	360		
BLU 1000.1	VCS-125	-	GT-K2-VCS125-RP25-BLU/MULTI	FGDR-RP40	-	165	500	option дополнительно	
	VCS-240	-	GT-K2-VCS240-RP40-BLU/MULTI	FGDR-RP40	24	55	500		
	VCS-350	-	GT-K2-VCS350-RP50-BLU/MULTI	FGDR-RP50	-	25	500		
	MBDLE412	-	GT-D2-MBDLE412-RP32-BLU/MULTI	-	40	75	360		
	MBDLE415	-	GT-D2-MBDLE415-RP40-BLU/MULTI	included включены	25	35	360		
	MBDLE420	-	GT-D2-MBDLE420-RP50-BLU/MULTI	-	-	27	360		
BLU 1200.1 Low NOx	VCS-240	-	GT-K2-VCS240-RP40-BLU/MULTI	FGDR-RP40	30	65	500	option дополнительно	
	VCS-350	-	GT-K2-VCS350-RP50-BLU/MULTI	FGDR-RP50	-	30	500		
	MBDLE412	-	GT-D2-MBDLE412-RP32-BLU/MULTI	-	50	75	360		
	MBDLE415	-	GT-D2-MBDLE415-RP40-BLU/MULTI	included включены	30	35	360		
	MBDLE420	-	GT-D2-MBDLE420-RP50-BLU/MULTI	-	-	27	360		
	VGD20.503	-	GT-S2-VGD20-RP50-BLU/MULTI	Filter 2"	-	20	600		option / дополнительно
BLU 1200.1	VCS-240	-	GT-K2-VCS240-RP40-BLU/MULTI	FGDR-RP40	30	80	500	option дополнительно	
	VCS-350	-	GT-K2-VCS350-RP50-BLU/MULTI	FGDR-RP50	-	35	500		
	MBDLE412	-	GT-D2-MBDLE412-RP32-BLU/MULTI	-	50	100	360		
	MBDLE415	-	GT-D2-MBDLE415-RP40-BLU/MULTI	included включены	30	50	360		
	MBDLE420	-	GT-D2-MBDLE420-RP50-BLU/MULTI	-	-	40	360		
	VGD20.503	-	GT-S2-VGD20-RP50-BLU/MULTI	Filter 2"	-	25	600		option / дополнительно
BLU 1500.1 Low NOx	VCS-240	-	GT-K2-VCS240-RP40-BLU/MULTI	FGDR-RP40	60	130	500	KITTC-VPSS04-VCS	
	VCS-240	-	GT-K2-VCS240-RP40-BLU/MULTI	FGDR-RP50	-	95	500		
	VCS-350	-	GT-K2-VCS350-RP50-BLU/MULTI	FGDR-RP50	-	60	500		
	MBDLE412	-	GT-D2-MBDLE412-RP32-BLU/MULTI	-	50	100	360		
	MBDLE415	-	GT-D2-MBDLE415-RP40-BLU/MULTI	included включены	45	67	360		
	MBDLE420	-	GT-D2-MBDLE420-RP50-BLU/MULTI	-	-	54	360		
	VGD20.503	-	GT-S2-VGD20-RP50-BLU/MULTI	Filter 2"	-	40	600		KITTC-VPSS04-VGD20503
	VGD40.065	GTCP-DN65-260	GT-S2-VGD40-DN65-BLU/MULTI	Filter DN65	-	30	700		KITTC-VPSS04-MB-VGDDN65-80

	GT	GTCP Gas Train Connection Pipe	GT Designation	Gas governor & filter / Filter	Gas pressure [mbar]			KITTC Tightness control EN676
					LPG min	GN min	max	
BLU 1700.1	VCS-240		GT-K2-VCS240-RP40-BLU/MULTI	FGDR-RP40	63	150	500	KITTC-VP5504-VCS
	VCS-240	GTCP-RP50-280	GT-K2-VCS240-RP40-BLU/MULTI	FGDR-RP50	-	105	500	
	VCS-350		GT-K2-VCS350-RP50-BLU/MULTI	FGDR-RP50	32	65	500	KITTC-VP5504-MB-VGDDN65-80
	MBDLE415		GT-D2-MBDLE415-RP40-BLU/MULTI	included	45	85	360	
	MBDLE420	GTCP-RP50-280	GT-D2-MBDLE420-RP50-BLU/MULTI	включены	35	60	360	
	VGD20.503		GT-S2-VGD20-RP50-BLU/MULTI	Filter 2"	-	45	600	KITTC-VP5504-VGD20503
	VGD40.065	GTCP-DN65-260/280/320	GT-S2-VGD40-DN65-BLU/MULTI	Filter DN65	-	30	700	KITTC-VP5504-MB-VGDDN65-80
	VGD40.080	GTCP-DN80-260/280/320	GT-S2-VGD40-DN80-BLU/MULTI	Filter DN80	-	20	700	
BLU 2000.1	VCS-240		GT-K2-VCS240-RP40-BLU/MULTI	FGDR-RP40	90	220	500	KITTC-VP5504-VCS
	VCS-240	GTCP-RP50-280	GT-K2-VCS240-RP40-BLU/MULTI	FGDR-RP50	-	155	500	
	VCS-350		GT-K2-VCS350-RP50-BLU/MULTI	FGDR-RP50	40	90	500	KITTC-VP5504-MB-VGDDN65-80
	MBDLE415		GT-D2-MBDLE415-RP40-BLU/MULTI	included	55	100	360	
	MBDLE420	GTCP-RP50-280	GT-D2-MBDLE420-RP50-BLU/MULTI	включены	45	75	360	
	VGD20.503		GT-S2-VGD20-RP50-BLU/MULTI	Filter 2"	-	60	600	KITTC-VP5504-VGD20503
	VGD40.065	GTCP-DN65-260/280/320	GT-S2-VGD40-DN65-BLU/MULTI	Filter DN65	-	35	700	KITTC-VP5504-MB-VGDDN65-80
	VGD40.080	GTCP-DN80-260/280/320	GT-S2-VGD40-DN80-BLU/MULTI	Filter DN80	-	23	700	
BLU 3000.1	VCS-350	GTCP-RP50-320/380	GT-K2-VCS350-RP50-BLU/MULTI	FGDR-RP50	70	160	500	KITTC-VP5504-VCS
	VGD20.503		GT-S2-VGD20-RP50-BLU/MULTI	Filter 2"	45	100	600	KITTC-VP5504-VGD20503
	VGD40.065	GTCP-DN65-260/280/320	GT-S2-VGD40-DN65-BLU/MULTI	Filter DN65	-	55	700	KITTC-VP5504-MB-VGDDN65-80
	VGD40.080	GTCP-DN80-260/280/320	GT-S2-VGD40-DN80-BLU/MULTI	Filter DN80	-	35	700	
	VGD40.100	GTCP-DN80-380 + GTCP-REDUCERDN100TODN80	GT-S2-VGD40-DN100-BLU/MULTI	Filter DN100	-	22	700	KITTC-VDK200
BLU 4000.1	VCS-350	GTCP-RP50-320/380	GT-K2-VCS350-RP50-BLU/MULTI	FGDR-RP50	110	280	500	KITTC-VP5504-VCS
	VGD20.503		GT-S2-VGD20-RP50-BLU/MULTI	Filter 2"	70	170	600	KITTC-VP5504-VGD20503
	VGD40.065	GTCP-DN65-260/280/320	GT-S2-VGD40-DN65-BLU/MULTI	Filter DN65	-	90	700	KITTC-VP5504-MB-VGDDN65-80
	VGD40.080	GTCP-DN80-260/280/320	GT-S2-VGD40-DN80-BLU/MULTI	Filter DN80	-	50	700	
	VGD40.100	GTCP-DN80-380 + GTCP-REDUCERDN100TODN80	GT-S2-VGD40-DN100-BLU/MULTI	Filter DN100	-	30	700	KITTC-VDK200
BLU 5000.1	VGD20.503	GTCP-RP50-320/380	GT-S2-VGD20-RP50-BLU/MULTI	Filter 2"	-	250	600	KITTC-VP5504-VGD20503
	VGD40.065	GTCP-DN65-380	GT-S2-VGD40-DN65-BLU/MULTI	Filter DN65	65	140	700	KITTC-VP5504-MB-VGDDN65-80
	VGD40.080	GTCP-DN80-380	GT-S2-VGD40-DN80-BLU/MULTI	Filter DN80	-	75	700	
	VGD40.100	GTCP-DN80-380 + GTCP-REDUCERDN100TODN80	GT-S2-VGD40-DN100-BLU/MULTI	Filter DN100	-	45	700	KITTC-VDK200
	VGD40.125	GTCP-DN125-380	GT-S2-VGD40-DN125-BLU/MULTI	Filter DN115	-	35	700	
BLU 6000.1	VGD20.503	GTCP-RP50-320/380	GT-S2-VGD20-RP50-BLU/MULTI	Filter 2"	-	340	600	KITTC-VP5504-VGD20503
	VGD40.065	GTCP-DN65-380	GT-S2-VGD40-DN65-BLU/MULTI	Filter DN65	90	180	700	KITTC-VP5504-MB-VGDDN65-80
	VGD40.080	GTCP-DN80-380	GT-S2-VGD40-DN80-BLU/MULTI	Filter DN80	-	100	700	
	VGD40.100	GTCP-DN80-380 + GTCP-REDUCERDN100TODN80	GT-S2-VGD40-DN100-BLU/MULTI	Filter DN100	-	60	700	KITTC-VDK200
	VGD40.125	GTCP-DN125-380	GT-S2-VGD40-DN125-BLU/MULTI	Filter DN115	-	50	700	
BLU 7000.1	VGD40.065	GTCP-DN65-630	GT-S2-VGD40-DN65-BLU/MULTI	Filter DN65	125	280	700	KITTC-VP5504-MB-VGDDN65-80
	VGD40.080	GTCP-DN80-630/710	GT-S2-VGD40-DN80-BLU/MULTI	Filter DN80	-	140	700	
	VGD40.100	GTCP-DN100-630/710	GT-S2-VGD40-DN100-BLU/MULTI	Filter DN100	-	75	700	KITTC-VDK200
	VGD40.125	GTCP-DN100-630/710 + GTCP-REDUCERDN125TODN100	GT-S2-VGD40-DN125-BLU/MULTI	Filter DN115	-	60	700	
	BLU 8000.1	VGD40.065	GTCP-DN65-630	GT-S2-VGD40-DN65-BLU/MULTI	Filter DN65	185	410	700
VGD40.080		GTCP-DN80-630/710	GT-S2-VGD40-DN80-BLU/MULTI	Filter DN80	-	210	700	
VGD40.100		GTCP-DN100-630/710	GT-S2-VGD40-DN100-BLU/MULTI	Filter DN100	-	110	700	KITTC-VDK200
VGD40.125		GTCP-DN100-630/710 + GTCP-REDUCERDN125TODN100	GT-S2-VGD40-DN125-BLU/MULTI	Filter DN115	-	85	700	
BLU 10000.1		VGD40.065	GTCP-DN65-630	GT-S2-VGD40-DN65-BLU/MULTI	Filter DN65	250	550	700
	VGD40.080	GTCP-DN80-630/710	GT-S2-VGD40-DN80-BLU/MULTI	Filter DN80	-	290	700	
	VGD40.100	GTCP-DN100-630/710	GT-S2-VGD40-DN100-BLU/MULTI	Filter DN100	110	165	700	KITTC-VDK200
	VGD40.125	GTCP-DN100-630/710 + GTCP-REDUCERDN125TODN100	GT-S2-VGD40-DN125-BLU/MULTI	Filter DN115	-	115	700	
	BLU 12000.1	VGD40.080	GTCP-DN80-630/710	GT-S2-VGD40-DN80-BLU/MULTI	Filter DN80	230	420	700
VGD40.100		GTCP-DN100-630/710	GT-S2-VGD40-DN100-BLU/MULTI	Filter DN100	160	230	700	KITTC-VDK200
VGD40.125		GTCP-DN100-630/710 + GTCP-REDUCERDN125TODN100	GT-S2-VGD40-DN125-BLU/MULTI	Filter DN115	-	175	700	
BLU 15000.1	VGD40.080	GTCP-DN80-630/710	GT-S2-VGD40-DN80-BLU/MULTI	Filter DN80	225	450	700	KITTC-VP5504-MB-VGDDN65-80
	VGD40.100	GTCP-DN100-630/710	GT-S2-VGD40-DN100-BLU/MULTI	Filter DN100	135	230	700	KITTC-VDK200
	VGD40.125	GTCP-DN100-630/710 + GTCP-REDUCERDN125TODN100	GT-S2-VGD40-DN125-BLU/MULTI	Filter DN115	-	150	700	
BLU 18000.1	VGD40.080	GTCP-DN80-630/710	GT-S2-VGD40-DN80-BLU/MULTI	Filter DN80	325	210	700	KITTC-VP5504-MB-VGDDN65-80
	VGD40.100	GTCP-DN100-630/710	GT-S2-VGD40-DN100-BLU/MULTI	Filter DN100	190	330	700	KITTC-VDK200
	VGD40.125	GTCP-DN100-630/710 + GTCP-REDUCERDN125TODN100	GT-S2-VGD40-DN125-BLU/MULTI	Filter DN115	-	150	700	

• HOW TO CALCULATE THE OVERALL DIMENSIONS OF BURNER COMPLETE WITH THE MATCHING GAS TRAIN

In order to calculate the overall dimensions of the burner complete with gas train, you have to consider value “N” and “V” indicated in the burner leaflet and the dimension of the matching gas train chosen, according to the inlet gas pressure available in the gas train leaflet.

• КАК РАССЧИТАТЬ ОБЩИЕ ГАБАРИТНЫЕ РАЗМЕПЫ ГОРЕЛКИ ВМЕСТЕ С ГАЗОВОЙ РАМПЫ

Для расчета общих габаритных размеров горелки вместе с газовой рампой возьмите размеры “N” и “V”, указанные в документации на горелку, и размеры соответствующей газовой рампы, приведенные в таблице сочетаний горелок и рамп, содержащейся в каталоге газовых рамп.

• COMMENT CALCULER LES DIMENSIONS DES BRULEURS AVEC LES RAMPES DE GAZ

Pour calculer les dimensions du brûleurs avec la rampe gaz, il faut considerer les valeurs “N” et “V” indiquées sur le catalogue du brûleur et les dimensions de la rampe gaz choisie en accord avec la pression disponible qui est possible de trouver sur le catalogue des rampes gaz.

• COMO CALCULAR LAS DIMENSIONES TOTALES DEL QUEMADOR Y LA RAMPA DE GAS CORRESPONDIENTES

Para calcular las dimensiones totales del quemador con el circuito del gas, se necesita tener en cuenta los valores N y V que se indican en el libro de instrucciones del quemador y las dimensiones del correspondiente circuito de gas elegido en base a la tabla de presiones disponible en el libro de instrucciones del circuito de gas.

BLU 700.1 ÷ BLU 1500.1

BLU 1700 ÷ BLU 18000.1

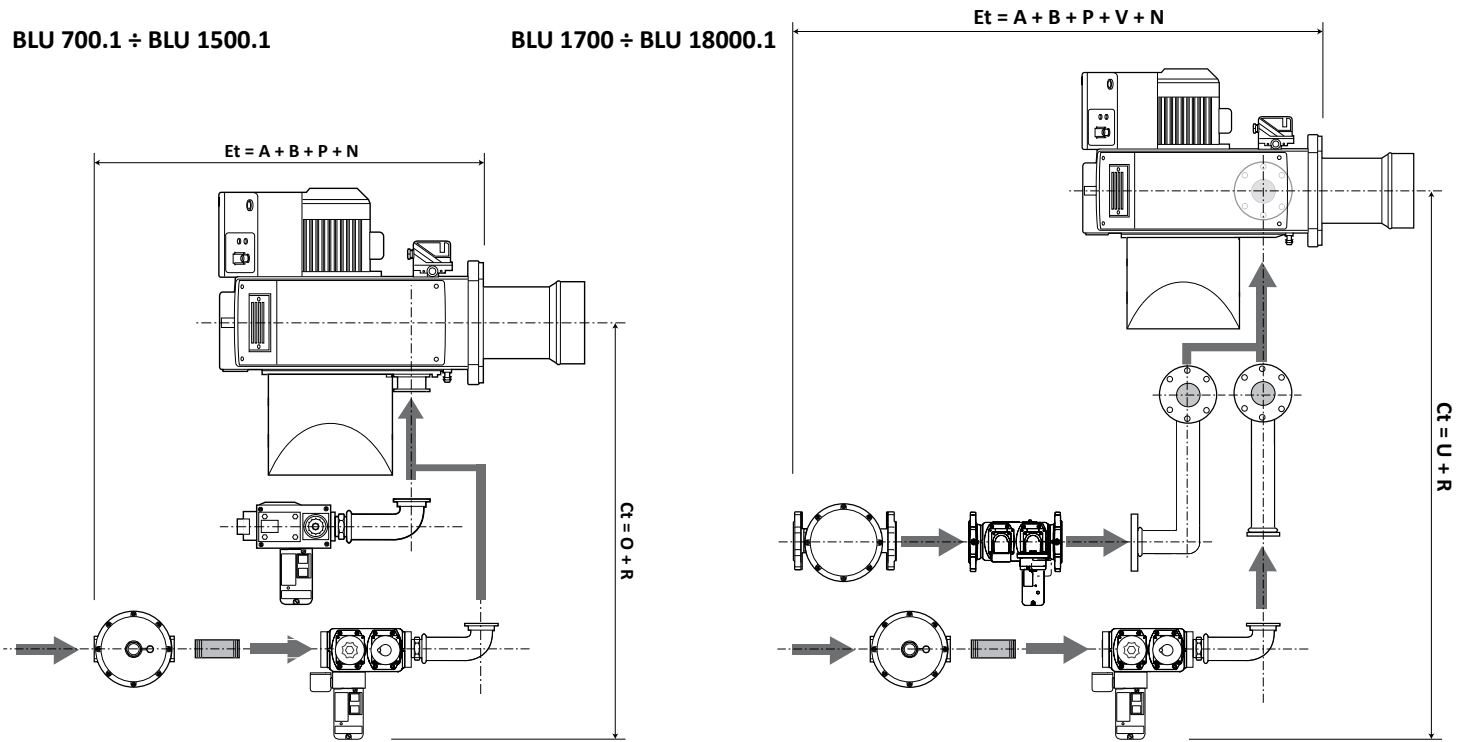

SWIRL SYSTEM • ВИХРЕВАЯ ОГНЕВАЯ ГОЛОВКА • SYSTÈME SWIRL • SISTEMA SWIRL

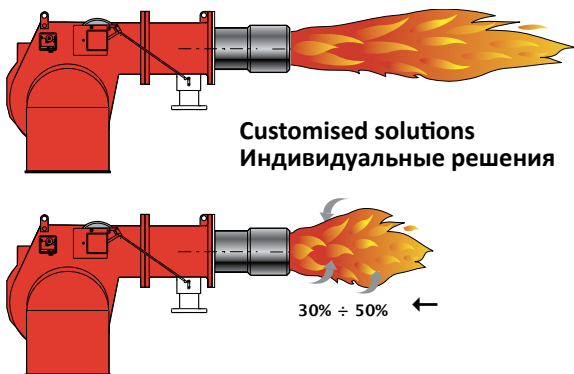

Customised solutions
Индивидуальные решения

- Swirls for blast tube that can reduce fame lenght up to 10-50% depending on fuel, backpressure and shape of combuston chamber
- Завихрители на огневой трубе позволяют уменьшить длину пламени на 10-50% в зависимости от топлива, противоавления и формы топки
- Les swirls de tête de combustion peuvent réduire la longueur de la flamme de 10 à 50% selon le combustible, la pression et la forme du foyer
- Torbellinos en el tubo de flama que reducen la longitud de la misma hasta un 10-50% dependiendo del combustible, la contra-presión y la forma de la cámara de combustión

BLU 700.1 ÷ BLU 1500.1

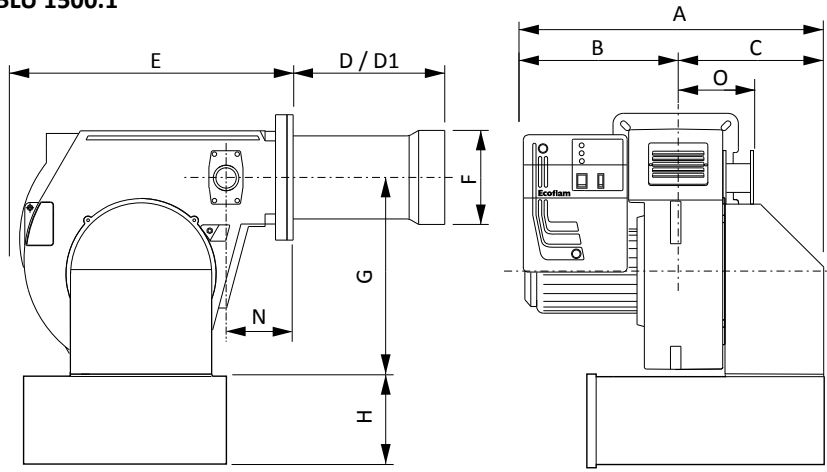

BLU 1700 ÷ BLU 18000.1

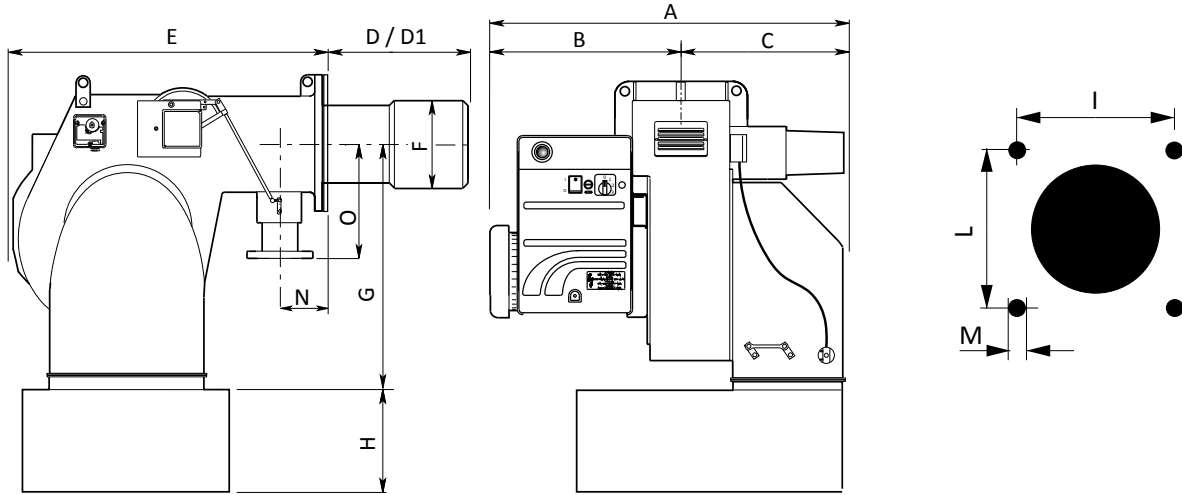

	A	B	C	D	D1	E	F	G	H	I	L	M	N	O
BLU 700.1 Low NOx	650	330	320	175	335	555	170	385	225*	190	190	M10	140	165
BLU 1000.1	650	330	320	175	335	555	190	385	225*	190	190	M10	140	165
BLU 1000.1 Low NOx	650	330	320	175	335	555	190	385	225*	190	190	M10	140	165
BLU 1200.1	670	350	320	310	460	555	200	385	225*	190	190	M10	140	165
BLU 1200.1 Low NOx	670	350	320	310	460	555	200	385	225*	190	190	M10	140	165
BLU 1500.1 Low NOx	710	385	325	340	540	680	215	398	283*	240	240	M14	140	190
BLU 1700.1	710	385	325	340	540	680	250	398	283*	240	240	M14	125	250
BLU 2000.1	730	405	325	345	545	680	270	398	283*	240	240	M14	125	250
BLU 3000.1	941	448	493	330	530	780	290	466	280	315	315	M16	195	250
BLU 4000.1	941	448	493	365	565	780	320	466	280	315	315	M16	195	250
BLU 5000.1	1019	495	524	375	575	970	320	565	400	330	330	M16	195	250
BLU 6000.1	1069	545	524	375	575	970	320	565	400	330	330	M16	195	250
BLU 7000.1	1210	585	625	470	-	1212	420	770	500	460	460	M20	195	232
BLU 8000.1	1280	655	625	470	-	1212	420	770	500	460	460	M20	195	232
BLU 10000.1	1310	685	625	470	-	1212	420	770	500	460	460	M20	195	232
BLU 12000.1	1420	795	625	470	-	1212	450	770	500	460	460	M20	195	232
BLU 15000.1	1670	800	870	590	-	1750	550	1100	500	620	620	M20	210	320
BLU 18000.1	1670	800	870	590	-	1750	550	1100	500	620	620	M20	210	320

• Dimensions in mm
D: short head
D1: long head
*: optional silencer

• Размеры в мм
D: короткая огневая головка
D1: длинная огневая головка
*: шумоглушитель в комплект поставки не включен

• Dimensions en mm
D: tête courte
D1: tête longue
*: silencieux en option

• Dimensiones in mm
D: cabeza corta
D1: cabeza larga
*: silenciador opcional

MultiBloc

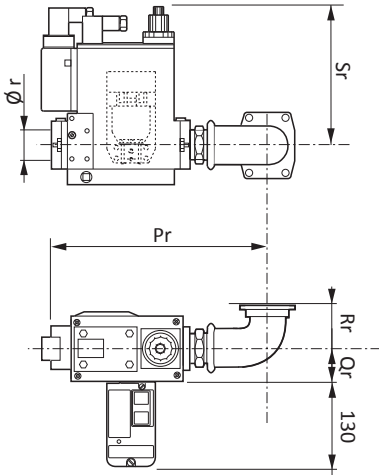

VCS + FGDR

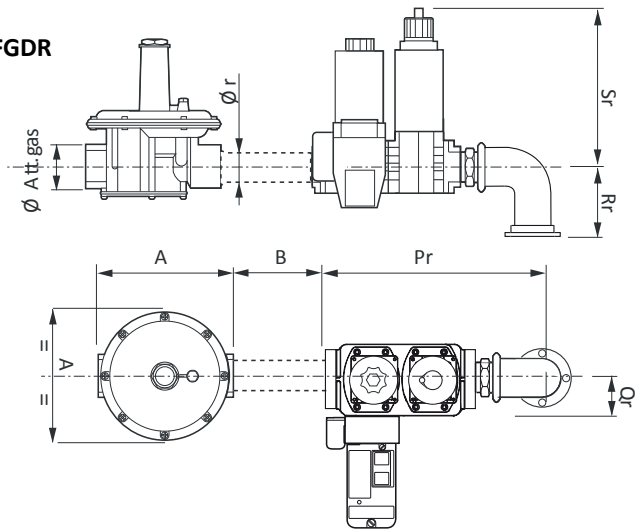

	GT	GTCP Dimension			GT Dimension				Gas governor & filter / Filter	FGDR - Filter		
		T	U	V	Pr	Qr	Rr	Ø r		A	A1	B
BLU 700.1 Low NOx	VCS-125	-	-	-	275	150	309	1"	FGDR-RP25	105	105	>100
	VCS-125	-	-	-	275	150	309	1"	FGDR-RP40	185	185	>100
	VCS-240	-	-	-	335	167	327	1" 1/2	FGDR-RP40	185	185	>100
	VCS-350	-	-	-	372	180	335	2"	FGDR-RP50	260	260	>100
	MBDLE410	-	-	-	330	145	275	1"				
	MBDLE412	-	-	-	330	145	275	1" 1/4				
	MBDLE415	-	-	-	410	145	275	1" 1/2	included включены	-	-	-
	MBDLE420	-	-	-	420	145	275	2"				
BLU 1000.1 Low NOx	VCS-125	-	-	-	275	150	309	1"	FGDR-RP40	185	185	>100
	VCS-240	-	-	-	335	167	327	1" 1/2	FGDR-RP40	185	185	>100
	VCS-350	-	-	-	372	180	335	2"	FGDR-RP50	260	260	>100
	MBDLE412	-	-	-	330	145	275	1" 1/4				
	MBDLE415	-	-	-	410	145	275	1" 1/2	included включены	-	-	-
	MBDLE420	-	-	-	420	145	275	2"				
BLU 1000.1	VCS-125	-	-	-	275	150	309	1"	FGDR-RP40	185	185	>100
	VCS-240	-	-	-	335	167	327	1" 1/2	FGDR-RP40	185	185	>100
	VCS-350	-	-	-	372	180	335	2"	FGDR-RP50	260	260	>100
	MBDLE412	-	-	-	330	145	275	1" 1/4				
	MBDLE415	-	-	-	410	145	275	1" 1/2	included включены	-	-	-
	MBDLE420	-	-	-	420	145	275	2"				
BLU 1200.1 Low NOx	VCS-240	-	-	-	335	167	327	1" 1/2	FGDR-RP40	185	185	>100
	VCS-350	-	-	-	372	180	335	2"	FGDR-RP50	260	260	>100
	MBDLE412	-	-	-	330	145	275	1" 1/4				
	MBDLE415	-	-	-	410	145	275	1" 1/2	included включены	-	-	-
	MBDLE420	-	-	-	420	145	275	2"				
	VG D20.503	-	-	-	450	185	315	2"	Filter 2"	230	148	>100
BLU 1200.1	VCS-240	-	-	-	335	167	327	1" 1/2	FGDR-RP40	185	185	>100
	VCS-350	-	-	-	372	180	335	2"	FGDR-RP50	260	260	>100
	MBDLE412	-	-	-	330	145	275	1" 1/4				
	MBDLE415	-	-	-	410	145	275	1" 1/2	included включены	-	-	-
	MBDLE420	-	-	-	420	145	275	2"				
	VG D20.503	-	-	-	450	185	315	2"	Filter 2"	230	148	>100
BLU 1500.1 Low NOx	VCS-240	-	-	-	335	167	327	1" 1/2	FGDR-RP40	185	185	>100
	VCS-240	-	-	-	335	167	327	1" 1/2	FGDR-RP50	260	260	>100
	VCS-350	-	-	-	372	180	335	2"	FGDR-RP50	260	260	>100
	MBDLE412	-	-	-	330	145	275	1" 1/4				
	MBDLE415	-	-	-	410	145	275	1" 1/2	included включены	-	-	-
	MBDLE420	-	-	-	420	145	275	2"				
	VG D20.503	-	-	-	450	185	315	2"	Filter 2"	230	148	>100
BLU 1700.1	VG D40.065	169	207	-	290	97	211	DN65	Filter DN65	290	212	>100
	VCS-240	85	400	-	335	167	327	1" 1/2	FGDR-RP40	185	185	>100
	VCS-240	85	400	-	335	167	327	1" 1/2	FGDR-RP50	260	260	>100
	VCS-350	85	400	-	372	180	335	2"	FGDR-RP50	260	260	>100
	MBDLE415	85	400	-	410	145	275	1" 1/2				
	MBDLE420	85	400	-	420	145	275	2"	included включены	-	-	-
	VG D20.503	85	400	-	450	185	315	2"	Filter 2"	230	148	>100
	VG D40.065	104	560	104	290	97	211	DN65	Filter DN65	290	212	>100
	VG D40.080	125	560	125	310	102	218	DN80	Filter DN80	320	240	>100
BLU 2000.1	VCS-240	85	400	-	335	167	327	1" 1/2	FGDR-RP40	185	185	>100
	VCS-240	85	400	-	335	167	327	1" 1/2	FGDR-RP50	260	260	>100
	VCS-350	85	400	-	372	180	335	2"	FGDR-RP50	260	260	>100
	MBDLE415	85	400	-	410	145	275	1" 1/2				
	MBDLE420	85	400	-	420	145	275	2"	included включены	-	-	-
	VG D20.503	85	400	-	450	185	315	2"	Filter 2"	230	148	>100
	VG D40.065	104	560	104	290	97	211	DN65	Filter DN65	290	212	>100
	VG D40.080	125	560	125	310	102	218	DN80	Filter DN80	320	240	>100

VGD20...

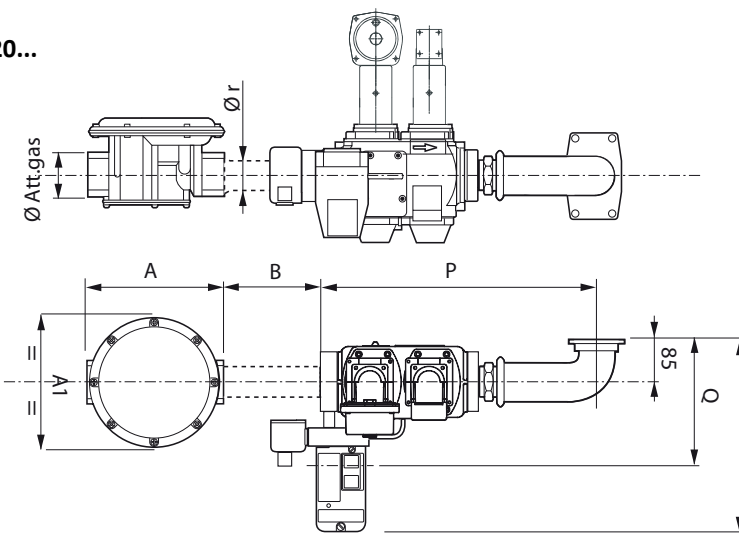

VGD40...

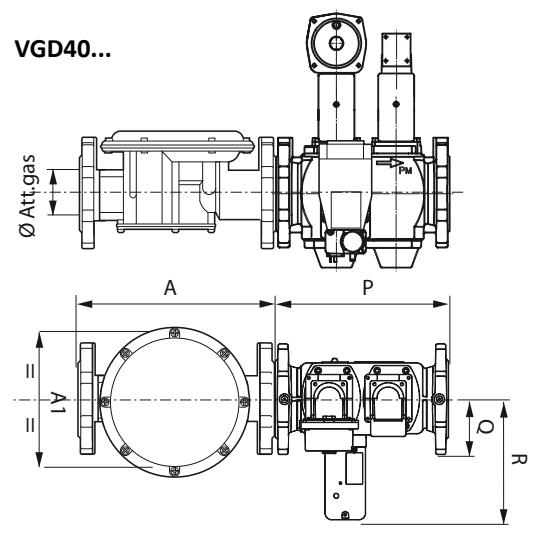

GTCP

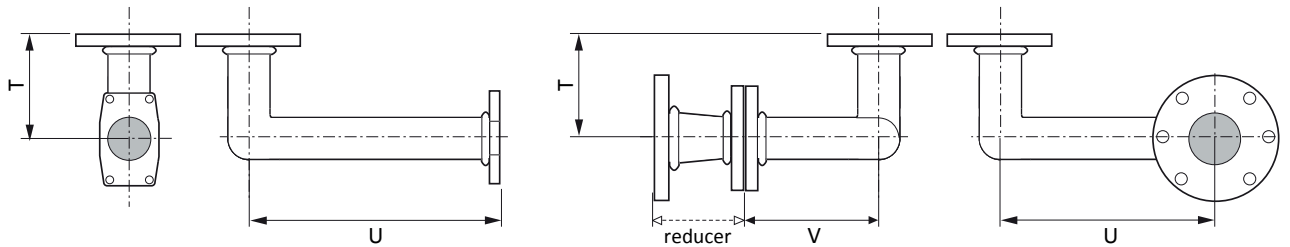

	GT	GTCP Dimension			GT Dimension			Gas governor & filter / Filter	FGDR - Filter			
		T	U	V	Pr	Qr	Rr		Ø r	A	A1	B
BLU 3000.1	VCS-350	85	588	-	372	180	335	2"	FGDR-RP50	260	260	>100
	VGD20.503	85	588	-	450	185	315	2"	Filter 2"	230	148	>100
	VGD40.065	104	560	104	290	97	211	DN65	Filter DN65	290	212	>100
	VGD40.080	125	560	125	310	102	218	DN80	Filter DN80	320	240	>100
BLU 4000.1	VGD40.100	125	560	255	350	113,5	229	DN100	Filter DN100	380	280	>100
	VCS-350	85	588	-	372	180	335	2"	FGDR-RP50	260	260	>100
	VGD20.503	85	588	-	450	185	315	2"	Filter 2"	230	148	>100
	VGD40.065	104	560	104	290	97	211	DN65	Filter DN65	290	212	>100
BLU 5000.1	VGD40.080	125	560	125	310	102	218	DN80	Filter DN80	320	240	>100
	VGD40.100	125	560	255	350	113,5	229	DN100	Filter DN100	380	280	>100
	VGD20.503	85	588	-	450	185	315	2"	Filter 2"	260	260	>100
	VGD40.065	125	668	125	290	97	211	DN65	Filter DN65	230	148	>100
BLU 6000.1	VGD40.080	125	668	125	310	102	218	DN80	Filter DN80	290	212	>100
	VGD40.100	125	560	255	350	113,5	229	DN100	Filter DN100	320	240	>100
	VGD40.125	125	718	164	400	127,5	243	DN125	Filter DN125	380	280	>100
	VGD20.503	85	588	-	450	185	315	2"	Filter 2"	260	260	>100
BLU 7000.1	VGD40.065	125	668	125	290	97	211	DN65	Filter DN65	230	148	>100
	VGD40.080	202	820	108	290	97	211	DN65	Filter DN65	230	148	>100
	VGD40.100	221	820	129	310	102	218	DN80	Filter DN80	290	212	>100
	VGD40.125	165	820	165	350	113,5	229	DN100	Filter DN100	320	240	>100
BLU 8000.1	VGD40.100	165	820	165	400	127,5	243	DN125	Filter DN125	380	280	>100
	VGD40.065	202	820	108	290	97	211	DN65	Filter DN65	230	148	>100
	VGD40.080	221	820	129	310	102	218	DN80	Filter DN80	290	212	>100
	VGD40.100	165	820	165	350	113,5	229	DN100	Filter DN100	320	240	>100
BLU 10000.1	VGD40.125	165	820	441	400	127,5	243	DN125	Filter DN125	380	280	>100
	VGD40.065	202	820	108	290	97	211	DN65	Filter DN65	230	148	>100
	VGD40.080	221	820	129	310	102	218	DN80	Filter DN80	290	212	>100
	VGD40.100	165	820	165	350	113,5	229	DN100	Filter DN100	320	240	>100
BLU 12000.1	VGD40.125	165	820	441	400	127,5	243	DN125	Filter DN125	380	280	>100
	VGD40.080	221	820	129	310	102	218	DN80	Filter DN80	290	212	>100
	VGD40.100	165	820	165	350	113,5	229	DN100	Filter DN100	320	240	>100
	VGD40.125	165	820	441	400	127,5	243	DN125	Filter DN125	380	280	>100
BLU 15000.1	VGD40.080	221	820	129	310	102	218	DN80	Filter DN80	290	212	>100
	VGD40.100	165	820	165	350	113,5	229	DN100	Filter DN100	320	240	>100
	VGD40.125	165	820	441	400	127,5	243	DN125	Filter DN125	380	280	>100
	VGD40.080	221	820	129	310	102	218	DN80	Filter DN80	290	212	>100
BLU 18000.1	VGD40.100	165	820	165	350	113,5	229	DN100	Filter DN100	320	240	>100
	VGD40.125	165	820	441	400	127,5	243	DN125	Filter DN125	380	280	>100
	VGD40.080	221	820	129	310	102	218	DN80	Filter DN80	290	212	>100

Ecoflam

Ecoflam Bruciatori S.p.A.

Via Roma, 64 - 31023 Resana (TV) - Italy

Tel. +39 0423 719500

Fax +39 0423 719580

<http://www.ecoflam-burners.com>

e-mail: export@ecoflam-burners.com

Società soggetta alla direzione e al coordinamento di Ariston Thermo S.p.A.

Via A. Merloni, 45 - 60044 Fabriano (AN) - CF 01026940427

Version 1.1

Date: 09/03/2011

- Ecoflam Bruciatori S.p.A. reserves the right to make any adjustments, without prior notice, which is considered necessary or useful to its products, without affecting their main features
- “Ecoflam Bruciatori S.p.A.” оставляет за собой право вносить в конструкцию оборудования любые необходимые изменения без особого предупреждения
- La maison Ecoflam Bruciatori S.p.A. se réserve le droit d’apporter les modifications qu’elle jugera nécessaires ou utiles à ses produits sans pour autant nuire à leurs caractéristiques principales
- Ecoflam Bruciatori S.p.A. se reserva el derecho a introducir en sus productos todas las modificaciones que considere necesarias o utiles, sin perjudicar sus características