

Technical manual for 2x1 air conditioning systems

GB



CE

COMPANY
WITH QUALITY SYSTEM
CERTIFIED BY DNV
=ISO 9001/2000=

TABLE OF CONTENTS

1	THE PATENT	3
2	CONSTRUCTIVE FEATURES	4
3	RATINGS AND TECHNICAL DATA	5
4	OVERALL DIMENSIONS	5
5	PERFORMANCE	6
5.1	COOLING - 2 PIPE SYSTEMS	6
5.2	COOLING - 4 PIPE SYSTEMS	7
5.3	HEATING - 2 PIPE SYSTEMS	8
5.4	HEATING - 4 PIPE SYSTEMS	9
5.5	SOUND LEVEL	10
6	WIRING DIAGRAMS	10
7	ACCESSORIES	11

DECLARATION OF CONFORMITY 

Galletti S.p.A., whose main office is in via Romagnoli 12/a, 40010 Bentivoglio (Bologna) - Italy, hereby declares, under its sole responsibility, that the 2X1 units, indoor units for heating and air conditioning systems, conform to the specifications of EEC Directives 73/23, 89/392, 91/368, 93/44, 93/68, 89/336, 98/37 and subsequent amendments.

Bologna, 03.04.06
Luigi Galletti
President

OPERATING LIMITS

- > thermal carrier fluid: water
- > water temperature: from 5°C to 95°C
- > maximum water pressure during operation: 10 bar
- > air temperature: from 5°C to 43 °C
- > Supply voltage: +/- 10%

1 THE PATENT

2x1 by Galletti: Evolution in air conditioning

Only someone who has been designing and manufacturing heating and air conditioning units for 45 years could have conceived a product which transcends the limits of existing technology.

2x1 is an indoor unit for hydronic heating and cooling systems which combines two operating modes in a single unit.

Thanks to an exclusive patented design, 2x1 can function as a heater without the aid of a fan, exploiting instead the principle of natural convection.

In summertime 2x1 offers the advantages of the best fan coil units, cooling, dehumidifying and filtering the air inside the room.

The exclusive patent combines 2 different operating modes in a single unit:

2 different air flow routes inside the unit and 2 distinct heat exchangers make it possible to switch over from natural convection heating to ventilated cooling or heating.



Heating: 3 operation mode, 5 thermal emission levels:

- > **1st level - convection heating mode**, fan off, flap open. The thermostat controls the room temperature by acting on the valve (optional), which interrupts the flow of water. The unit can be shut down immediately by positioning the air outlet flap in the closed position.
- > **2nd level - convection heating mode**, fan speed set on extra low, flap open. The thermostat controls the room temperature by acting on the fan and valve (optional), which interrupts the flow of water.
- > **3rd / 4th / 5th level - fan coil mode**, fan speed on low, medium or high, flap closed. The thermostat controls the room temperature by acting on the fan and valve (optional), which interrupts the flow of water.

COOLING: 1 OPERATING MODE, 4 LEVELS OF COOL AIR DELIVERY

- > **1st / 2nd / 3rd / 4th level - fan coil mode**, fan speed set on EXTRA-LOW, low, medium or high, flap closed. The thermostat controls the room temperature by acting on the fan and valve (optional), which interrupts the flow of water.

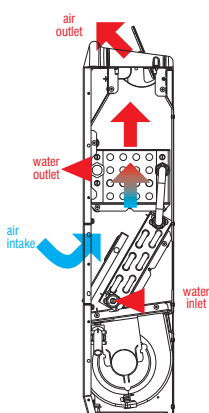

Heating
Static convector mode
Natural convection

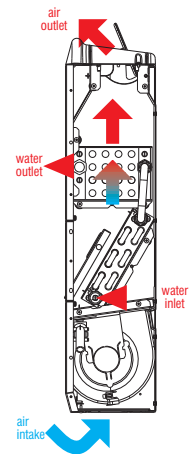

Heating
Static convector mode
EXTRA-LOW operation

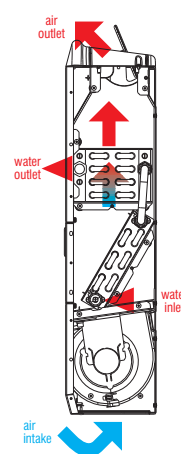

Heating
Fan coil mode
Maximum, medium, minimum operation

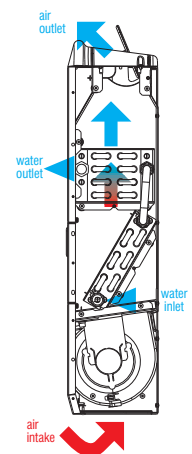

Cooling
Fan coil mode
Extra-low, maximum, medium, minimum operation

2 CONSTRUCTIVE FEATURES

- > CABINET WITH A REFINED DESIGN
 - Front panel made of sheet steel, colour RAL9010. The front panel incorporates an exclusive air flap which activates the convection heating mode. The flap is opened and closed manually.
 - Side panels manufactured from UV-stabilised ABS to maintain the colour intact over time.
 - Upper grill made of ABS (UV stabilised), adjustable louvers and flap. The flap features a microswitch that automatically shuts down the unit when the flap itself is closed. The side doors provide access to the control panel and compartment housing the plumbing connections. The doors may be secured by screws to prevent opening.
- > HEAT EXCHANGERS

2X1 incorporates 2 heat exchangers for 2 distinct operating modes.

 - 4-row convector exchanger made up of copper tubing and aluminium fins secured to the tubing by mechanical expansion, complete with brass manifolds and air vent valve. The wide spacing between fins optimises the draught effect during natural convection.
 - Fan coil exchanger, made up of copper tubing and high-efficiency aluminium fins submitted to a hydrophilic surface treatment, secured to the tubing by mechanical expansion. The exchanger comes complete with air vent valves.
 - The heat exchangers are normally connected in series, so that the 2x1 unit will be ready for installation in 2-pipe systems. By removing the connecting pipe, 2x1 can be immediately converted for installation in a 4-pipe system, where the convector exchanger will be connected to the heating circuit and the fan coil exchanger to the cooling circuit.
 - The plumbing connections are normally provided on the left side but may be switched over to the other side (180°) during unit installation.
- > FAN ASSEMBLY

Including centrifugal fans with staggered airfoil-shaped blades, manufactured from anti-static ABS. The fans are housed in a low-noise ABS volute distinguished by a compact, high-efficiency profile. Four-speed electrical motor, mounted on vibration damping couplings, directly connected to the fans, with permanently activated capacitor and winding thermal protection .
- > BEARING STRUCTURE

Bearing structure built from galvanised sheet steel of adequate thickness, insulated by means of Class 1 self-extinguishing panels, supplied with an installation kit (wall screws). A support terminal board for electrical connections is located on the bearing structure, on the opposite side of the plumbing connections.
- > AIR FILTER

Honey-comb polypropylene washable air filter, mounted on a galvanised sheet frame protected by a net, easily removable for maintenance operations. The filter may be secured to the unit by means of screws.
- > ACCESSORIES
 - Speed switch
 - Microprocessor panel for automatic control of the unit and the connection to the ERGO control system
 - Base support panels which conceal the pipes leading up from the floor
 - Water flow regulating valves
 - BIOXIGEN ionisation and purification system

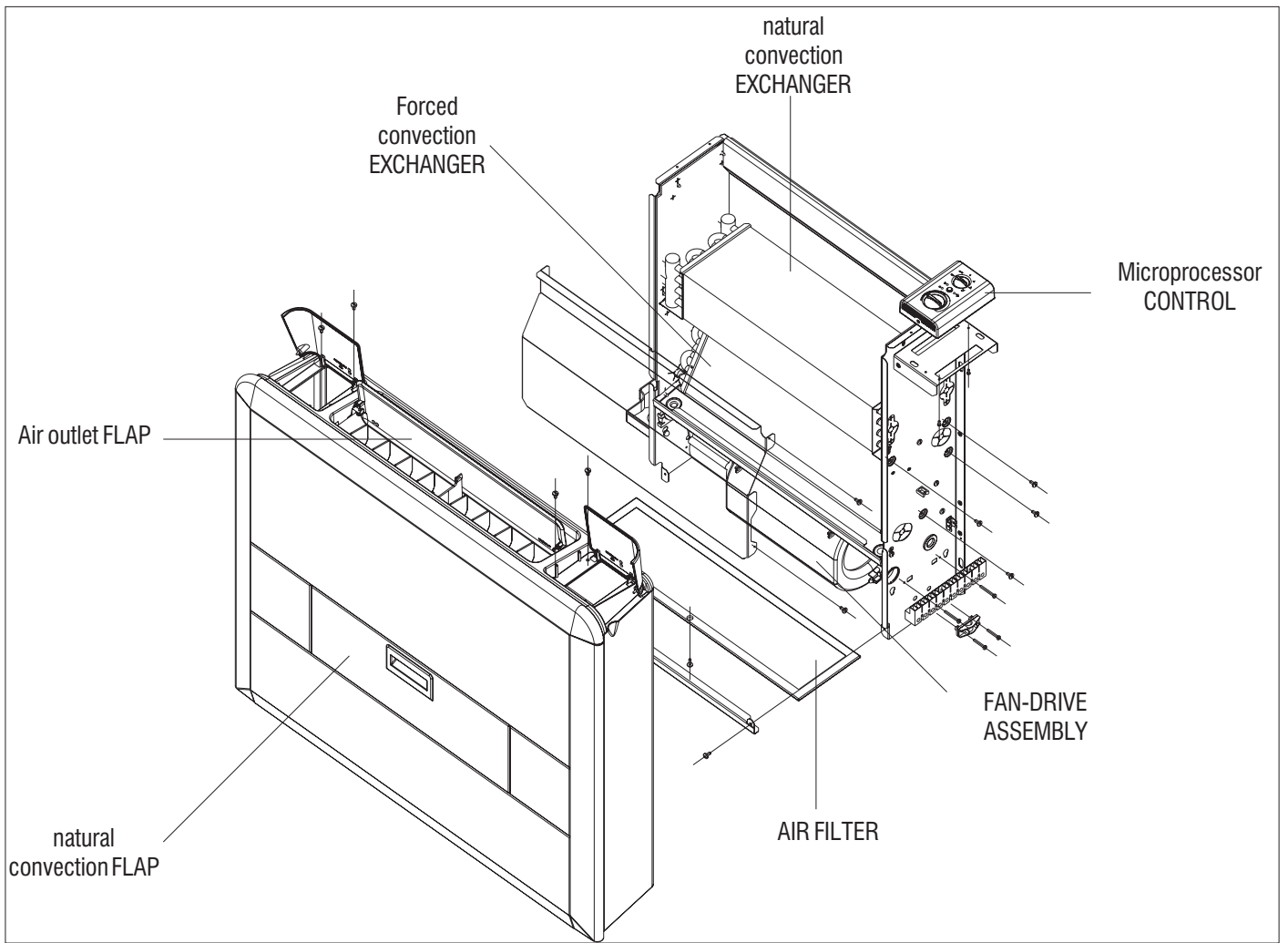

3 RATINGS AND TECHNICAL DATA

			COOLING water 7/12°C, air dry bulb 27°C humid bulb 19°C)					HEATING water 75/65°C, air 20°C)				
MODEL	Ventilation	Air flow rate	Total capacity	Sensible capacity	Dehum. Capacity	Water flow rate	Pressure drop	Capacity	water flow rate	Pressure drop	Electrical input	Sound power level
		m ³ /h	kW	kW	l/h	l/h	kPa	kW	l/h	kPa	watt	dB A
124	convection	-	-	-	-	-	-	0,93	80	0,5	-	-
	extra-low	80	0,56	0,39	0,24	95	1,5	1,74	80	0,5	11	27
	minimum	110	0,74	0,52	0,32	125	2,0	1,86	165	2,5	12	29
	medium	135	0,90	0,64	0,37	155	3,0	2,24	195	3,0	17	34
	maximum	170	1,17	0,95	0,32	200	5,0	2,89	255	3,5	23	40
224	convection	-	-	-	-	-	-	1,30	115	1,1	-	-
	extra-low	100	0,70	0,49	0,30	120	1,2	1,95	115	1,1	12	31
	minimum	135	0,87	0,64	0,34	150	1,9	2,30	205	3,0	14	33
	medium	170	1,14	0,80	0,49	190	2,6	2,85	250	4,5	20	37
	maximum	225	1,62	1,34	0,40	275	4,5	3,54	310	6,5	27	43
324	convection	-	-	-	-	-	-	1,49	130	1,1	-	-
	extra-low	140	1,04	0,70	0,48	175	2,7	2,74	130	1,1	22	32
	minimum	200	1,48	1,00	0,68	250	5,0	3,38	295	6,0	23	34
	medium	250	1,82	1,24	0,84	305	7,0	4,13	365	9,0	28	39
	maximum	340	2,38	1,82	0,80	410	13,5	5,10	450	13,0	37	46
424	convection	-	-	-	-	-	-	1,49	130	1,1	-	-
	extra-low	175	1,28	0,89	0,56	225	4,0	3,34	130	1,1	22	33
	minimum	250	1,82	1,17	0,94	305	7,0	4,13	365	9,0	25	34
	medium	310	2,17	1,50	0,97	375	10,0	5,00	440	13,0	31	40
	maximum	420	3,13	2,32	1,17	540	20,0	5,89	520	18,0	42	47

- 1 Water temperature 7-12°C, air temperature 27°C dry bulb, 19°C wet bulb (47% relative humidity).
- 2 Water inlet temperature 50°C, water flow rate same as in cooling mode, air inlet temperature 20°C
3. Water temperature 75 - 65°C; air temperature 20°C
4. Sound power measured according to standards ISO3741 and ISO3742

4 OVERALL DIMENSIONS

- 1 Drain outlet Ø 17 mm
- 2 Water inlet, 2-pipe systems, Ø 1/2" female gas
- 3 Water outlet, 2-pipe systems, Ø 1/2" female gas
- 4 Cooling circuit water inlet, 4-pipe systems, Ø 1/2" female gas
- 5 Cooling circuit water outlet, 4-pipe systems, Ø 1/2" female gas
- 6 Heating circuit water connections, Ø 1/2" female gas

2x1	A	B	Weight	Water content		
				Cooling exchanger	Heating exchanger	Total
	mm	mm	kg	dm ³	dm ³	dm ³
124	820	534	21	0,49	0,73	1,22
224	990	704	25	0,65	0,97	1,62
324	1160	874	29	0,81	1,20	2,01
424	1160	874	29	0,81	1,20	2,01

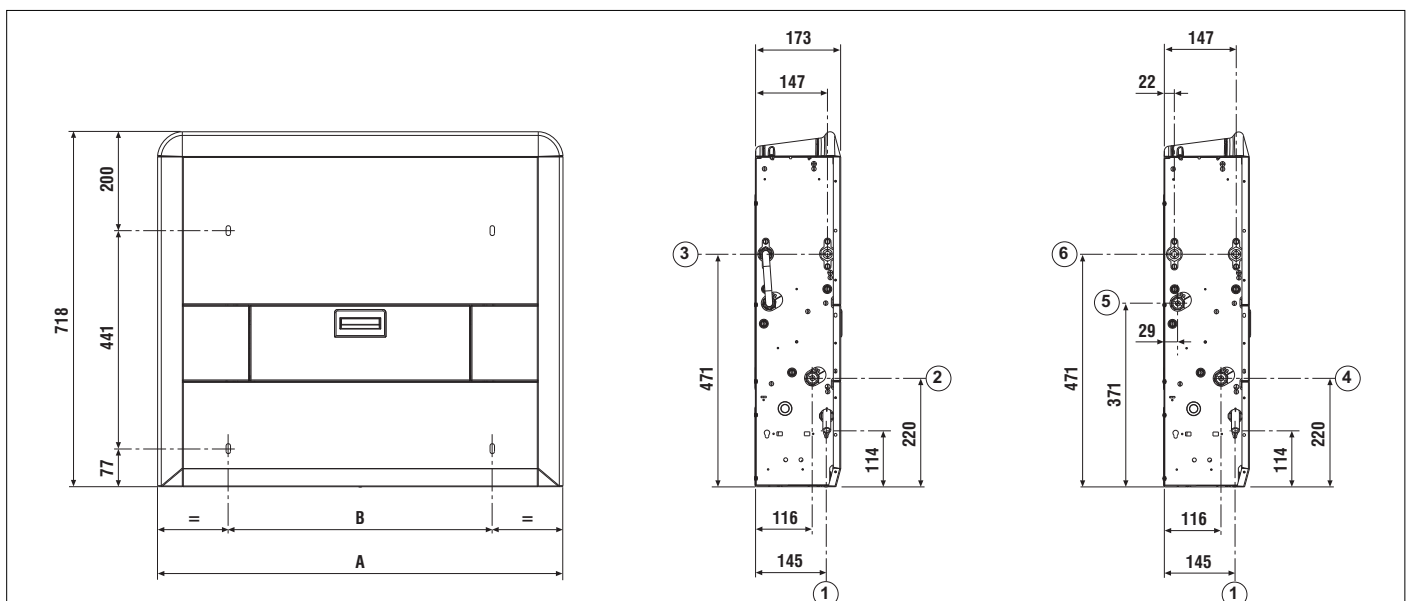

5 PERFORMANCE

5.1 COOLING - 2 PIPE SYSTEMS

- T_{bs1}** Air intake temperature (dry bulb)
T_{bu1} Air intake temperature (wet bulb)
T_{w1} Inlet water temperature
T_{w2} Water outlet temperature
V_r Fan speed:
 max maximum
 med medium
 min minimum
PFT Total cooling capacity
PFS Sensible cooling capacity
Q_w Water flow rate
Δpw Pressure drop, water side

NOTE: FRONT FLAP ALWAYS CLOSED

T _{bs1} / T _{bu1} (UR ₁)		25°C / 18°C (51%)															
T _{w1} / T _{w2}		6°C / 11°C				7°C / 12°C				8°C / 13°C				9°C / 14°C			
	V _r	PFT	PFS	Q _w	Δpw	PFT	PFS	Q _w	Δpw	PFT	PFS	Q _w	Δpw	PFT	PFS	Q _w	Δpw
		W	W	l/h	kPa	W	W	l/h	kPa	W	W	l/h	kPa	W	W	l/h	kPa
124	MAX	1120	830	192	5,0	960	760	164	4,0	760	680	131	2,0	670	670	116	2,0
	MED	850	650	147	3,0	720	590	124	2,0	640	560	110	2,0	560	520	95	1,0
	MIN	740	560	126	2,0	670	530	114	2,0	590	500	102	2,0	520	460	89	1,0
	extra low	620	470	107	2,0	560	440	97	1,0	500	420	86	1,0	440	390	75	1,0
224	MAX	1550	1130	265	5,0	1310	1020	226	3,0	1010	900	174	2,0	930	930	160	2,0
	MED	1060	790	182	2,0	950	750	164	2,0	850	700	145	2,0	740	660	127	1,0
	MIN	850	610	147	2,0	770	570	133	1,0	690	530	118	1,0	600	500	103	1,0
	extra low	680	450	117	1,0	620	420	106	1,0	550	390	95	1,0	480	370	83	1,0
324	MAX	2280	1660	391	13,0	2000	1540	343	10,0	1690	1400	289	7,0	1310	1310	226	5,0
	MED	1750	1270	299	8,0	1520	1170	261	6,0	1260	1060	216	4,0	1000	1000	173	3,0
	MIN	1410	1030	243	6,0	1220	940	209	4,0	1020	860	175	3,0	890	800	153	2,0
	extra low	1020	760	175	3,0	920	720	158	3,0	820	670	141	2,0	720	630	123	2,0
424	MAX	3020	2170	518	19,0	2670	2010	458	15,0	2290	1850	393	11,0	1850	1670	318	8,0
	MED	2080	1520	357	10,0	1820	1400	313	8,0	1530	1280	263	6,0	1200	1200	206	4,0
	MIN	1750	1270	299	7,0	1520	1170	261	6,0	1260	1060	216	4,0	1000	1000	173	3,0
	extra low	1210	910	208	4,0	1050	840	180	3,0	930	790	160	2,0	810	750	139	2,0

T _{bs1} / T _{bu1} (UR ₁)		27°C / 19°C (47%)															
T _{w1} / T _{w2}		6°C / 11°C				7°C / 12°C				8°C / 13°C				9°C / 14°C			
	V _r	PFT	PFS	Q _w	Δpw	PFT	PFS	Q _w	Δpw	PFT	PFS	Q _w	Δpw	PFT	PFS	Q _w	Δpw
		W	W	l/h	kPa	W	W	l/h	kPa	W	W	l/h	kPa	W	W	l/h	kPa
124	MAX	1320	960	226	6,0	1170	890	201	5,0	1010	820	173	4,0	820	750	140	3,0
	MED	1020	750	175	4,0	900	700	154	3,0	760	640	130	2,0	650	590	112	2,0
	MIN	880	650	151	3,0	770	600	133	2,0	680	560	117	2,0	600	530	104	2,0
	extra low	700	520	120	2,0	640	500	109	2,0	580	470	99	1,0	510	440	88	1,0
224	MAX	1820	1300	313	6,0	1620	1210	278	5,0	1390	1110	239	4,0	1110	990	190	3,0
	MED	1290	930	222	3,0	1130	860	193	3,0	970	790	167	2,0	860	750	148	2,0
	MIN	950	670	164	2,0	870	640	150	2,0	790	600	136	1,0	700	570	121	1,0
	extra low	770	500	131	1,0	700	470	120	1,0	630	450	109	1,0	570	420	97	1,0
324	MAX	2640	1890	452	16,0	2370	1770	407	14,0	2090	1650	358	11,0	1770	1520	304	8,0
	MED	2030	1450	348	10,0	1820	1350	312	9,0	1590	1260	274	7,0	1340	1150	230	5,0
	MIN	1650	1180	283	7,0	1480	1100	254	6,0	1280	1020	221	5,0	1050	920	180	3,0
	extra low	1170	860	200	4,0	1040	800	179	3,0	940	760	162	3,0	840	720	144	2,0
424	MAX	3460	2460	594	24,0	3130	2310	538	20,0	2780	2150	477	16,0	2390	1990	410	12,0
	MED	2410	1730	414	13,0	2170	1620	372	10,0	1900	1510	327	8,0	1610	1390	276	6,0
	MIN	2030	1450	348	9,0	1820	1350	312	8,0	1590	1260	274	6,0	1340	1150	230	4,0
	extra low	1450	1060	248	5,0	1280	980	220	4,0	1090	900	187	3,0	950	850	163	2,0

5 PERFORMANCE

5.2 COOLING - 4 PIPE SYSTEMS

- Tbs₁** Air intake temperature (dry bulb)
Tbu₁ Air intake temperature (wet bulb)
Tw₁ Inlet water temperature
Tw₂ Water outlet temperature
Vr Fan speed
max maximum
med medium
min minimum
PFT Total cooling capacity
PFS Sensible cooling capacity
Qw Water flow rate
Δpw Pressure drop, water side

NOTE: FRONT FLAP ALWAYS CLOSED

Tbs ₁ / Tbu ₁ (UR ₁)		25°C / 18°C (51%)															
Tw ₁ / Tw ₂		6°C / 11°C				7°C / 12°C				8°C / 13°C				9°C / 14°C			
Vr		PFT	PFS	Qw	Δpw	PFT	PFS	Qw	Δpw	PFT	PFS	Qw	Δpw	PFT	PFS	Qw	Δpw
		W	W	l/h	kPa	W	W	l/h	kPa	W	W	l/h	kPa	W	W	l/h	kPa
124	MAX	1040	770	178	4,0	880	700	151	3,0	700	630	121	2,0	640	640	110	2,0
	MED	800	600	136	3,0	690	550	119	2,0	610	520	106	2,0	530	490	92	1,0
	MIN	700	520	120	2,0	630	490	109	2,0	560	460	97	1,0	490	430	84	1,0
	extra low	590	420	101	2,0	530	400	92	1,0	480	370	82	1,0	410	350	71	1,0
224	MAX	1440	1060	246	4,0	1200	960	207	3,0	970	860	167	2,0	890	890	153	2,0
	MED	1020	760	175	2,0	920	720	158	2,0	820	670	140	1,0	710	630	122	1,0
	MIN	790	540	136	1,0	720	510	123	1,0	640	480	109	1,0	560	450	95	1,0
	extra low	640	380	109	1,0	570	350	99	1,0	510	330	88	1,0	450	300	77	1,0
324	MAX	2030	1400	348	10,0	1770	1290	303	8,0	1470	1170	252	6,0	1090	1020	187	3,0
	MED	1620	1150	278	7,0	1400	1060	240	5,0	1140	950	195	4,0	940	870	162	3,0
	MIN	1320	950	226	5,0	1120	870	192	4,0	980	800	168	3,0	850	750	146	2,0
	extra low	950	660	162	3,0	860	620	147	2,0	760	590	131	2,0	670	550	114	1,0
424	MAX	2800	1960	480	16,0	2460	1810	422	13,0	2090	1660	359	10,0	1670	1490	287	7,0
	MED	1940	1360	333	9,0	1690	1250	290	7,0	1400	1130	241	5,0	1120	1120	192	3,0
	MIN	1620	1150	278	6,0	1400	1060	240	5,0	1140	950	195	3,0	940	870	162	2,0
	extra low	1130	810	194	3,0	1010	760	173	3,0	890	710	154	2,0	780	660	134	2,0

Tbs ₁ / Tbu ₁ (UR ₁)		27°C / 19°C (47%)															
Tw ₁ / Tw ₂		6°C / 11°C				7°C / 12°C				8°C / 13°C				9°C / 14°C			
Vr		PFT	PFS	Qw	Δpw	PFT	PFS	Qw	Δpw	PFT	PFS	Qw	Δpw	PFT	PFS	Qw	Δpw
		W	W	l/h	kPa	W	W	l/h	kPa	W	W	l/h	kPa	W	W	l/h	kPa
124	MAX	1230	890	212	6,0	1090	820	187	5,0	930	760	160	3,0	930	760	160	3,0
	MED	960	690	164	4,0	840	640	144	3,0	710	590	121	2,0	710	590	121	2,0
	MIN	810	590	140	3,0	720	550	123	2,0	650	520	111	2,0	650	520	111	2,0
	extra low	660	470	113	2,0	600	450	104	2,0	550	420	94	1,0	550	420	94	1,0
224	MAX	1710	1220	293	6,0	1510	1130	259	4,0	1280	1040	220	3,0	1280	1040	220	3,0
	MED	1220	880	208	3,0	1050	810	180	2,0	940	760	161	2,0	940	760	161	2,0
	MIN	890	610	152	2,0	810	570	139	1,0	730	540	126	1,0	730	540	126	1,0
	extra low	710	420	122	1,0	650	400	112	1,0	590	370	101	1,0	590	370	101	1,0
324	MAX	2370	1600	406	14,0	2120	1500	364	11,0	1850	1390	317	9,0	1850	1390	317	9,0
	MED	1890	1320	325	9,0	1690	1230	290	7,0	1470	1140	253	6,0	1470	1140	253	6,0
	MIN	1550	1090	266	6,0	1380	1020	237	5,0	1190	940	204	4,0	1190	940	204	4,0
	extra low	1060	740	182	3,0	970	700	166	3,0	880	660	150	2,0	880	660	150	2,0
424	MAX	3220	2230	553	21,0	2910	2090	499	17,0	2560	1940	440	14,0	2560	1940	440	14,0
	MED	2260	1560	388	11,0	2020	1450	348	9,0	1770	1350	304	7,0	1770	1350	304	7,0
	MIN	1890	1320	325	8,0	1690	1230	290	7,0	1470	1140	253	5,0	1470	1140	253	5,0
	extra low	1360	940	233	5,0	1190	870	205	4,0	1030	800	177	3,0	1030	800	177	3,0

5 PERFORMANCE

5.3 HEATING - 2 PIPE SYSTEMS

Tbs₁ Air intake temperature (dry bulb)

Tw₁ Inlet water temperature

Tw₂ Water outlet temperature

Vr Fan speed

max maximum

med medium

min minimum

PT Heating capacity

Qw Water flow rate

Δpw Pressure drop, water side

Tbs ₁	20°C														
	Tw ₁ / Tw ₂	Vr	FLAP	45 / 40°C			60°C / 50°C			70°C / 60°C			90°C / 70°C		
				PT	Qw	Δ pw	PT	Qw	Δ pw	PT	Qw	Δ pw	PT	Qw	Δ pw
				W	l/h	kPa	W	l/h	kPa	W	l/h	kPa	W	l/h	kPa
124	MAX	closed	1290	225	5,2	2040	178	3,3	2610	229	5,0	3560	157	2,5	
	MED	closed	1000	174	3,3	1570	137	2,1	2020	178	3,2	2750	121	1,6	
	MIN	closed	820	143	2,4	1300	113	1,5	1680	147	2,3	2260	100	1,1	
	extra-low	open	690	121	1,8	1090	95	1,1	1410	124	1,7	1910	84	0,8	
	convection	open	279	48	0,2	542	47	0,2	790	68	0,4	1216	52	0,2	
224	MAX	closed	1560	272	5,9	2460	215	3,7	3180	279	5,6	4290	189	2,7	
	MED	closed	1260	219	4,0	1990	173	2,5	2560	225	3,9	3470	153	1,9	
	MIN	closed	1020	177	2,8	1610	141	1,8	2070	182	2,7	2810	124	1,3	
	extra-low	open	820	142	1,9	1300	113	1,2	1660	146	1,8	2270	100	0,9	
	convection	open	399	69	0,4	767	66	0,4	1112	96	0,8	1703	73	0,5	
324	MAX	closed	2270	395	11,7	3570	312	7,3	4590	403	11,1	6190	273	5,4	
	MED	closed	1850	321	8,1	2910	254	5,1	3720	327	7,7	5060	223	3,8	
	MIN	closed	1510	262	5,7	2380	208	3,6	3040	267	5,4	4150	183	2,7	
	extra-low	open	1160	201	3,6	1830	160	2,3	2340	206	3,4	3200	141	1,7	
	convection	open	461	79	0,4	882	76	0,4	1276	110	0,8	1948	84	0,5	
424	MAX	closed	2620	456	15,5	4100	358	9,7	5300	465	14,7	7110	314	7,1	
	MED	closed	2230	388	11,7	3510	307	7,4	4500	395	11,1	6110	270	5,4	
	MIN	closed	1850	321	8,4	2910	254	5,3	3720	327	7,9	5060	223	3,9	
	extra-low	open	1410	246	5,3	2230	195	3,3	2860	251	5,0	3890	172	2,5	
	convection	open	461	79	0,4	882	76	0,4	1276	110	0,8	1948	84	0,5	

Tbs ₁	22°C														
	Tw ₁ / Tw ₂	Vr	FLAP	45 / 40°C			60°C / 50°C			70°C / 60°C			90°C / 70°C		
				PT	Qw	Δ pw	PT	Qw	Δ pw	PT	Qw	Δ pw	PT	Qw	Δ pw
				W	l/h	kPa	W	l/h	kPa	W	l/h	kPa	W	l/h	kPa
124	MAX	closed	1170	204	4,4	1910	167	3,0	2480	218	4,5	3430	151	2,3	
	MED	closed	900	157	2,8	1470	129	1,9	1930	169	2,9	2640	117	1,5	
	MIN	closed	750	130	2,0	1220	106	1,3	1590	140	2,1	2180	96	1,0	
	extra-low	open	570	99	0,1	1020	90	1,0	1340	118	1,5	1840	81	0,8	
	convection	open	243	42	0,1	496	43	0,1	738	63	0,3	1156	50	0,2	
224	MAX	closed	1420	246	5,0	2300	201	3,3	3020	265	5,2	4130	182	2,6	
	MED	closed	1140	199	3,4	1860	163	2,3	2440	214	3,5	3340	147	1,8	
	MIN	closed	920	161	2,4	1510	132	1,6	1970	173	2,4	2710	120	1,2	
	extra-low	open	690	120	0,3	1220	106	1,1	1580	139	1,7	2190	96	0,8	
	convection	open	347	60	0,3	703	60	0,3	1040	89	0,7	1619	70	0,4	
324	MAX	closed	2060	359	9,9	3350	293	6,6	4370	384	10,2	5970	263	5,0	
	MED	closed	1680	291	6,9	2730	239	4,6	3540	311	7,0	4880	215	3,5	
	MIN	closed	1370	238	4,8	2230	195	3,2	2900	254	5,0	4000	176	2,5	
	extra-low	open	910	158	0,5	1720	150	2,0	2230	196	3,1	3080	136	1,6	
	convection	open	402	69	0,3	809	70	0,3	1194	103	0,7	1853	80	0,4	
424	MAX	closed	2380	413	13,1	3850	337	8,7	5040	442	13,5	6850	302	6,6	
	MED	closed	2030	353	9,9	3300	288	6,6	4290	376	10,2	5880	260	5,1	
	MIN	closed	1680	291	7,1	2730	239	4,7	3540	311	7,3	4880	215	3,7	
	extra-low	open	1080	188	0,7	2090	183	3,0	2720	239	4,6	3750	166	2,3	
	convection	open	402	69	0,3	809	70	0,3	1194	103	0,7	1853	80	0,4	

5 PERFORMANCE

5.4 HEATING - 4 PIPE SYSTEMS

Tbs₁ Air intake temperature (dry bulb)

Tw₁ Inlet water temperature

Tw₂ Water outlet temperature

Vr Fan speed

max maximum

med medium

min minimum

PT Heating capacity

Qw Water flow rate

Δpw Pressure drop, water side

Tbs ₁	20°C														
	Tw ₁ / Tw ₂	Vr	FLAP	45 / 40°C			60°C / 50°C			70°C / 60°C			90°C / 70°C		
				PT	Qw	Δpw	PT	Qw	Δpw	PT	Qw	Δpw	PT	Qw	Δpw
124		MAX	closed	920	160	0,3	1410	123	0,2	1930	170	0,3	2510	111	0,1
		MED	closed	800	138	0,2	1240	108	0,1	1650	145	0,2	2140	94	0,1
		MIN	closed	720	125	0,2	1120	98	0,1	1470	129	0,2	1920	85	0,1
		extra-low	open	630	109	0,1	980	86	0,1	1260	111	0,1	1690	74	0,1
		convection	open	279	48	0,2	542	47	0,2	790	68	0,4	1216	52	0,2
224		MAX	closed	1230	214	0,9	1900	166	0,5	2560	224	0,9	3350	148	0,4
		MED	closed	1010	176	0,6	1570	137	0,4	2120	186	0,6	2780	123	0,3
		MIN	closed	860	149	0,5	1340	117	0,3	1790	157	0,5	2350	104	0,2
		extra-low	open	760	132	0,4	1190	104	0,2	1560	137	0,4	2050	90	0,2
		convection	open	399	69	0,4	767	66	0,4	1112	96	0,8	1703	73	0,5
324		MAX	closed	1790	312	1,7	2790	244	1,1	3690	323	1,7	4870	215	0,8
		MED	closed	1470	256	1,2	2290	200	0,7	3030	266	1,2	4010	177	0,6
		MIN	closed	1260	219	0,9	1960	171	0,6	2590	227	0,9	3440	152	0,4
		extra-low	open	1010	176	0,6	1580	138	0,4	2090	184	0,6	2790	123	0,3
		convection	open	461	79	0,4	882	76	0,4	1276	110	0,8	1948	84	0,5
424		MAX	closed	2040	354	2,2	3160	276	1,4	4180	367	2,1	5510	243	1,0
		MED	closed	1690	295	1,6	2630	230	1,0	3480	305	1,6	4600	203	0,7
		MIN	closed	1470	256	1,3	2290	200	0,8	3030	266	1,2	4010	177	0,6
		extra-low	open	1200	209	0,9	1870	164	0,5	2480	217	0,9	3290	145	0,4
		convection	open	461	79	0,4	882	76	0,4	1276	110	0,8	1948	84	0,5

Tbs ₁	22°C														
	Tw ₁ / Tw ₂	Vr	FLAP	45 / 40°C			60°C / 50°C			70°C / 60°C			90°C / 70°C		
				PT	Qw	Δpw	PT	Qw	Δpw	PT	Qw	Δpw	PT	Qw	Δpw
124		MAX	closed	830	144	0,2	1330	116	0,2	1830	161	0,3	2400	106	0,1
		MED	closed	720	125	0,2	1160	101	0,1	1560	137	0,2	2050	90	0,1
		MIN	closed	650	113	0,2	1050	92	0,1	1390	122	0,2	1850	82	0,1
		extra-low	open	570	99	0,1	920	80	0,1	1200	105	0,1	1620	72	0,1
		convection	open	243	42	0,1	496	43	0,1	738	63	0,3	1156	50	0,2
224		MAX	closed	1100	191	0,7	1770	155	0,5	2430	213	0,8	3210	142	0,4
		MED	closed	910	158	0,5	1460	128	0,3	2010	176	0,6	2660	118	0,3
		MIN	closed	780	135	0,4	1260	110	0,3	1700	149	0,4	2250	99	0,2
		extra-low	open	690	120	0,3	1110	97	0,2	1480	130	0,3	1970	87	0,2
		convection	open	347	60	0,3	703	60	0,3	1040	89	0,7	1619	70	0,4
324		MAX	closed	1620	281	1,4	2600	228	0,9	3500	307	1,5	4680	207	0,7
		MED	closed	1320	230	1,0	2140	187	0,7	2880	252	1,1	3850	170	0,5
		MIN	closed	1130	197	0,8	1830	160	0,5	2460	216	0,8	3310	146	0,4
		extra-low	open	910	158	0,5	1470	128	0,3	1990	174	0,6	2680	118	0,3
		convection	open	402	69	0,3	809	70	0,3	1194	103	0,7	1853	80	0,4
424		MAX	closed	1830	319	1,8	2950	258	1,2	3970	349	2,0	5300	234	0,9
		MED	closed	1530	265	1,3	2460	215	0,9	3310	290	1,4	4420	195	0,7
		MIN	closed	1320	230	1,0	2140	187	0,7	2880	252	1,1	3850	170	0,5
		extra-low	open	1080	188	0,7	1750	153	0,5	2350	207	0,8	3160	140	0,4
		convection	open	402	69	0,3	809	70	0,3	1194	103	0,7	1853	80	0,4

5 PERFORMANCE

5.5 SOUND LEVEL

Vr Fan speed

3=maximum

2=medium

1=minimum

Lw Sound power level by octave band, not weighted

Lw_A Total sound power level, weighted A

Lp_A Total sound pressure level, weighted A, measured in an open field, at a distance of 1 m, with a directivity factor of 4

	Vr	Lw								
		125 Hz	250 Hz	500 Hz	1000 Hz	2000 Hz	4000 Hz	8000 Hz	LwA	LpA
		dB	dB	dB	dB	dB	dB	dB	dB/A	dB/A
124	MAX	39,0	42,6	40,6	32,0	22,4	15,8	15,2	40	35
	MED	31,2	38,0	34,0	23,7	15,8	14,7	15,3	34	29
	MIN	29,1	33,9	28,8	17,0	13,8	14,4	16,3	29	24
	SMIN	27,6	31,3	26,8	15,0	11,0	14,3	16,3	27	22
224	MAX	36,5	44,6	43,1	34,4	28,9	29,3	20,0	43	38
	MED	32,7	40,7	35,6	26,6	24,9	27,1	18,4	37	32
	MIN	26,9	36,4	30,3	20,3	22,9	24,9	16,4	33	28
	SMIN	26,3	34,3	26,7	17,0	21,7	23,8	15,8	31	26
324	MAX	43,3	48,3	46,7	39,5	32,2	19,5	14,4	46	41
	MED	38,0	41,7	39,7	29,3	20,7	13,4	14,2	39	34
	MIN	36,9	38,6	33,7	22,5	13,7	13,1	15,2	34	29
	SMIN	35,4	36,2	30,2	19,9	10,0	13,1	15,2	32	27
424	MAX	44,3	49,3	47,7	40,5	33,2	20,5	15,4	47	42
	MED	39,0	42,7	40,7	30,3	21,7	13,4	15,2	40	35
	MIN	36,9	38,6	33,7	22,5	13,7	13,1	15,2	34	29
	SMIN	36,4	37,2	32,2	20,9	10,0	13,1	15,2	33	28

6 WIRING DIAGRAMS

Make the electrical connections with the mains power disconnected, in accordance with current safety regulations; strictly abide by the layout given in the appended diagram, which illustrates a 2x1 unit complete with **MICROK** microprocessor controller.

The electrical connections indicated must be made by the installer. For each fan coil an (IL) switch should be mounted on the power supply, with opening contacts at a distance of at least 3 mm and a suitable protection fuse (F) .

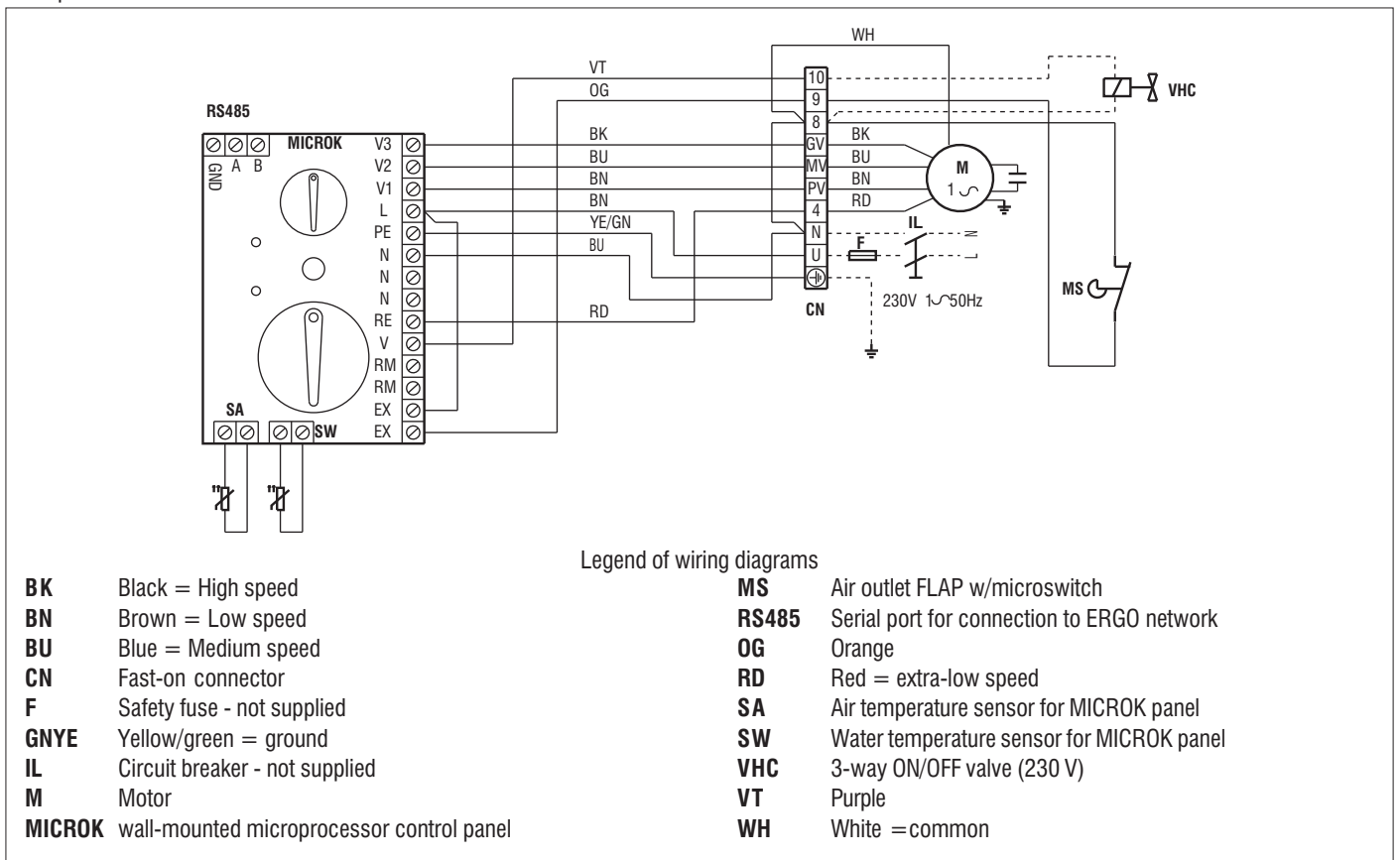

7 ACCESSORIES

CK Speed switch, installation on the unit.

Control panel for installation directly on the unit, featuring a selector for setting the fan speed (4 speeds) and shutting down the unit.

MICROK - advanced microprocessor control panel.

Microprocessor control panel to be installed on the wall or directly on the unit, complete with speed selector, electronic thermostat and cooling/heating changeover switch, suitable for connection to an ERGO supervision system.

It controls the fan speed and regulates the room temperature in the heating and cooling modes.

- Room temperature control in both the heating and cooling modes, achieved by switching the fan off and on, at the manually set speed.
- Room temperature control in both the heating and cooling modes, with automatic fan speed adjustment.
- Timer (where installed in the unit).
- Cooling/heating switching in the following modes: manual, on the unit; remote, manual (centralised); automatic, depending on water temperature; automatic, depending on air temperature.
- Control of ON/OFF valves.

MICROK is also equipped with

- input for remote enabling or disabling of unit operation
- input for remote enabling or disabling of the ECONOMY set point (only for systems controlled by ERGO software)
- Sensor for air and water temperature reading
- Optoisolated RS 485 communication port. No electricity supply required.
- Integrated MODBUS communication protocol
- INTEGRATED pull-up and pull-down resistors which may be activated via jumpers.



ZK - Two support covering feet

Supplied in pairs, they comprise supports for fastening to the base unit and outer coverings for fastening to the cabinet.

They are used to conceal the plumbing (pipes leading up from the floor) and in cases where the fan coil unit cannot be anchored to the wall. The height of the base support panels is 100 mm.

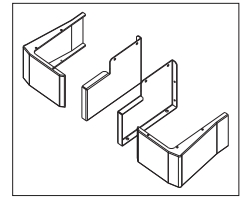

BV - Auxiliary water drip tray for vertical installation units, enabling collection of condensate from balancing/regulating valves.

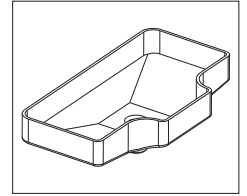

VK - ON-OFF 3-way motor driven valve, with hydraulic kit

The ON/OFF motor driven 3-way/4 collection VK valve kit controls the room temperature by stopping the water flow through the heat exchanger.

VK kit includes:

- Brass 3-way valve / 4 connections with built-in by-pass, maximum operating pressure 16 bar;
- Electrothermal actuator with the ON/OFF functions (total opening time 4 minutes), 230 V power supply.
- Plumbing kit for installing the valve on the heat exchanger, complete with 2 holders for balancing and regulating the fan coil unit.

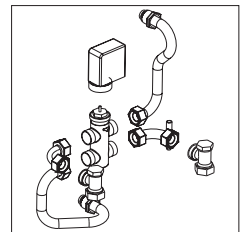



40010 Bentivoglio (BO)
Via Romagnoli, 12/a
Tel. 051/8908111
Fax 051/8908122
www.galletti.it