

O I L B O I L E R

▶ **GEODIS**



BAXI

GEODIS, is **sum**[®], GUARANTEED – TECHNOLOGY WHICH CHANGES YOUR LIFE

TRUE TECHNOLOGICAL PROWESS, BAXI'S HALLMARK A MASS PRODUCED FULLY FITTED RANGE OF OIL BOILERS, DELIVERED IN ONE SINGLE PACKAGE WITH BURNER, CONTROL UNIT, DOMESTIC HOT WATER TANK AND INCORPORATED CONNECTIONS.

WHAT'S MORE GEODIS IS FITTED WITH A HEAT EXCHANGER* OF UNIQUE DESIGN GIVING IT FOOLPROOF RELIABILITY.

ALL THESE PERFORMANCES ARE COMBINED UNDER THE SUM APPELLATION: SYSTEM UNIVERSEL MONOBLOC.*



GEODIS is **sum**[®] guaranteed by BAXI.

- Because it responds to the "System" concept by incorporating all vital functions for the user's well-being.
- Because it responds to the "Universel" concept by fitting all installation configurations with the greatest of ease.
- Because it responds to the "Monobloc" concept by guaranteeing the reliability of its heat exchanger.*

System: GEODIS IS MASS PRODUCED FULLY FITTED.

GEODIS is delivered fully fitted with all functions required for the user's well-being. Burner, domestic hot water tank and control unit are mass production fitted at the factory, the whole perfectly incorporated under an extremely rigid very carefully designed jacket.

Incorporating all components allows maximum performance optimization. Factory presettings and component compatibility are the guarantee of installation carried out with the greatest of ease under the best conditions for foolproof long lasting quality. Specially designed hermetically sealed cladding softens operating noise even more.



Incorporated control unit.



Incorporated burner.

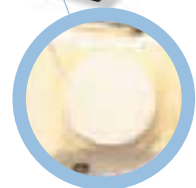

Incorporated hot water tank.

* Up to 30 kW models.

Universel: GEODIS **EASILY FITS ALL** **SITUATIONS.**

One of the feats of GEODIS is providing maximum boiler components of the highest level of comfort under minimum volume.

In the Bi version, the maximum height does not exceed 1.40 m to allow it to be incorporated by limiting the space used. Its control panel, thereby located at eye level, provides the advantage of being completely accessible.

GEODIS flexibility also resides in its control unit.

It guarantees the user the best comfort level while providing GEODIS optimized, so economical, control of it.

The control panel "Nomade" can be set on a pedestal in a living room for remote control of ambience and operating settings.

What's more, the GEODIS control unit is capable of meeting all a plant's requirements; from basic needs to the most sophisticated plants.

The plant can be extended throughout the boiler's service life to fit changes in the house.



The control panel summarizes control unit operating instructions. So programming is simplified.

Monobloc: GEODIS **HAS A HEMISPHERICAL** **ONE PIECE HEAT** **EXCHANGER*.**

The GEODIS heat exchanger is the outcome of BAXI's know-how and outstanding mastery of all new foundry technologies.

One piece and hemispherical, it consists of single cast iron element with no welds and no connections which prevents any risk of leakage and guarantees GEODIS reliability, long lasting quality and performance.

RELIABILITY

The hemispherical shape gives outstanding pressure resistance; thermal stresses are applied in a fully symmetrical way.

One piece body irrigation is ideal since water is not compartmentalised. The water circulates perfectly in the heat exchanger at a uniform temperature. The lack of a cold zone eliminates condensation risks.

LONG LASTING QUALITY

The GEODIS one piece design reduces stresses and so strengthens the heat exchanger's solidity.

The hemispherical shape makes possible a significant increase in heating area and combustion chamber volume. Thereby the boiler is thermally less loaded which is the guarantee of very long lasting quality.

PERFORMANCE

GEODIS performance is the outcome of its heat exchanger's specifics.

The hemispherical shape is geometrically favourable as it allows the external heat exchanger surface to be reduced. What's more, its wide door at the front eliminates heat losses.



*The unique GEODIS heat exchanger**

GEODIS achieves 93% annual operating output.
GEODIS is a high output boiler enjoying the ★★CE standard.

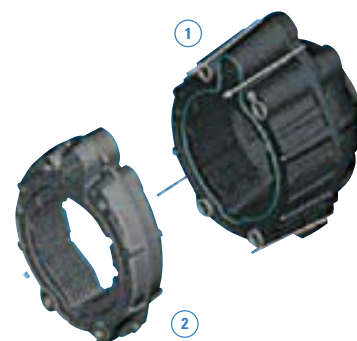

1 - GEODIS unique body common to all models.

2 - Specific element for models with more than 30 kW output.

* Up to 30 kW models.

GEODIS CHIMNEY VERSION, COME INTO THE WORLD OF COMFORT

A RANGE OF OIL BOILERS INTENDED FOR INDIVIDUAL PLANTS PROVIDED WITH A CHIMNEY. AVAILABLE IN TWO VERSIONS, HEATING ONLY, AND WITH DOMESTIC HOT WATER PRODUCTION, GEODIS PROVIDES MAXIMUM COMFORT FOR THE MOST DEMANDING USERS.



NOTE THE ADVANTAGES!



IDEALLY COMPACT

Geodis provides all functions required for optimum comfort in the minimum volume. It is easily incorporated in any space.



IDEAL PERFORMANCE

Geodis is the archetypal boiler for houses of standing and very many families thanks to striking capacity for heating or domestic hot water production.



IDEAL ENVIRONMENTAL FRIENDLINESS

Thanks to a very low level of pollution emission Geodis respects the environment.

RANGE.

GEODIS Bi

4 models: 24, 30, 40 and 50 kW.*

Boiler with domestic hot water production, incorporated burner and control unit.

GEODIS Ci

4 models: 24, 30, 40 and 50 kW.*

Boiler for heating only with incorporated burner and control unit to be fitted with a domestic hot water tank.

COMPACT.

Mass produced incorporation of Geodis fundamental functions allowed its volume to be considerably reduced making it the most compact boiler on the market. In the Bi version, its height is only 1.40 m and 0.85 m in the Ci version, for possible installation in all kinds of boiler rooms, with easy access to settings and data.

HIGH PERFORMANCE.

Geodis in the Bi version is delivered with its incorporated 130 or 170 litres hot water tank. Its specific discharge is 26 or 30 l/min equivalent to 260 or 300 litres of hot water available in 10 minutes.

Something to meet the needs of a large family or a luxury installation.

ECOLOGY.

The 500i burner enables the Geodis boiler get the best outputs. It operates over a wide range of CO₂ with no risk of fouling.

It has a low level of pollution emission with a NO_x rate less than 130 mg/kWh.

The flue gas discharge is perfect, what gives the boiler an outstanding acoustic performance level.

Thanks to the Geodis, hermetically sealed cladding, the noise level is considerably reduced compared with the previous generation of boilers.

	dBA pressure	dBA power
GEODIS 500 i	50	55.6* and 56*
HELIS on CRYSLIS	53	62
Previous generation	54	63.6

* CETIAT report according to NF EN 23741 for 24 and 30 kW

*New 2004

► GEODIS CHIMNEY - SECTIONAL VIEW

★★ CE GEODIS Bi models

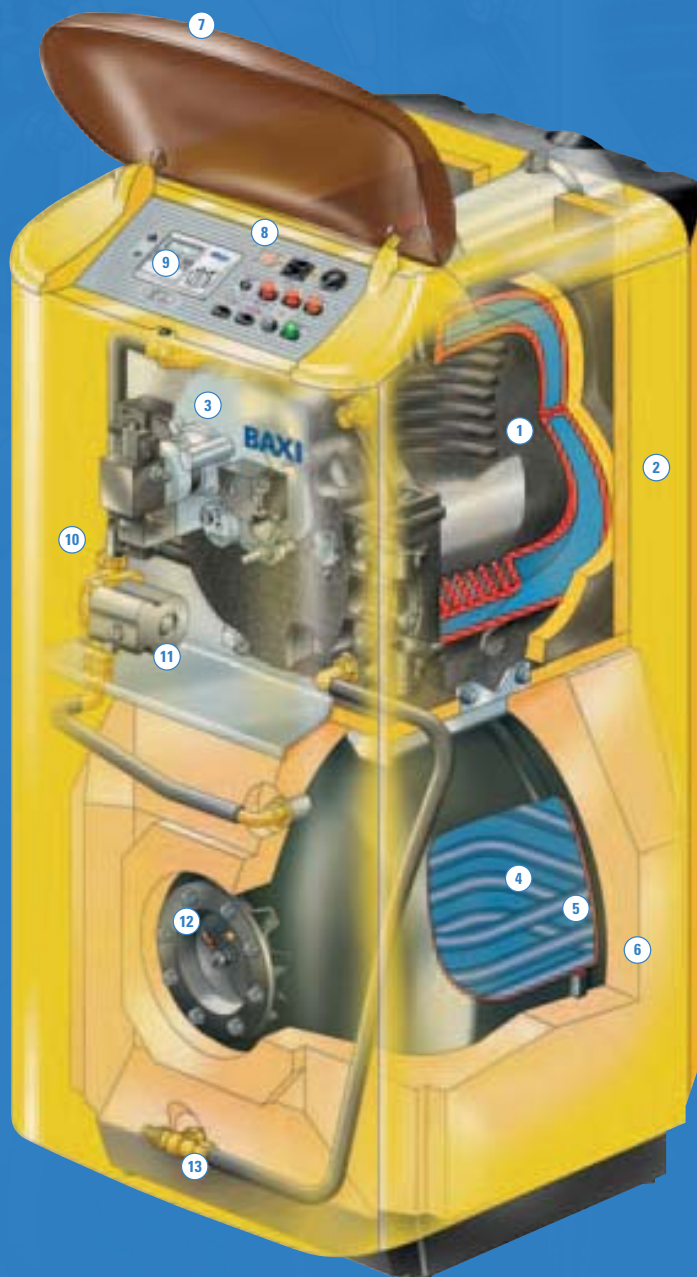

- 1 Cast iron one or two pieces hemispherical heat exchanger
- 2 Epoxy steel jacket
- 3 Incorporated burner
- 4 130/170 l hot water tank
- 5 Enamelled steel exchanger
- 6 CFC free polyurethane insulation
- 7 Translucent protective screen
- 8 Control panel
- 9 Detachable control unit
- 10 Soundproofed front
- 11 Domestic hot water load pump
- 12 Inspection flap
- 13 Drain cock

GEODIS FAN FLUE VERSION, NO CHIMNEY REQUIRED TO TAKE ADVANTAGE OF GEODIS COMFORT

PROVIDING THE SAME ACES AS ALL GEODIS BOILERS, THE FAN FLUE VERSION IS INSTALLED IN ALL KINDS OF LOCATIONS WHICH DO NOT HAVE CHIMNEYS.

DO YOU WANT RENOVATE AN EXISTING PLANT?

DO YOU WANT TO REPLACE AN ELECTRIC PLANT?

GEODIS FAN FLUE STANDS OUT AS THE IDEAL SOLUTION.



GEODIS BVi

GEODIS CVi

NOTE THE ADVANTAGES!

EASY INSTALLATION

The GEODIS FAN FLUE fits to a small room and finds its place anywhere in the house.

DISCRETION ITSELF

You can tell the GEODIS FAN FLUE is different because of its performance, not its operating noise. The fan flue system provides higher output and a significant reduction in noise levels.

RANGE.

GEODIS BVi

3 models: 25, 35 and 45 kW.*

Boiler with domestic hot water production, incorporated burner and control unit.

GEODIS CVi

3 models: 25, 35 and 45 kW.*

Boiler for heating only with incorporated burner and control unit to be fitted with a domestic hot water tank.

INSTALLATION.

GEODIS can be installed in any apartments not having chimneys or keeping chimneys for the pleasure of having wood fires, thanks to its fan flue system.

With air being taken from outside rooms GEODIS FAN FLUE can be installed in small volume unventilated places and be located anywhere in apartments: guaranteed space saving.

ITS SILENCE IS GOLDEN.

For user comfort, GEODIS FAN FLUE sound levels are well below those of previous generations. The fully sealed burner cover and fresh air intake through a duct directly connected to the outside are one of the GEODIS FAN FLUE acoustic performance factors.

	dBA pressure at 1m	dBA power*
GEODIS BVi/CVi	48.3	53.6
GEODIS Bi/Ci	50	56
Chimney boiler	54	63.6

* CETIAT report according to NF EN 23741 for 25 kW.

***New 2004**

▶ GEODIS EXTRACTOR - SECTIONAL VIEW

★★ CE GEODIS BVI Models

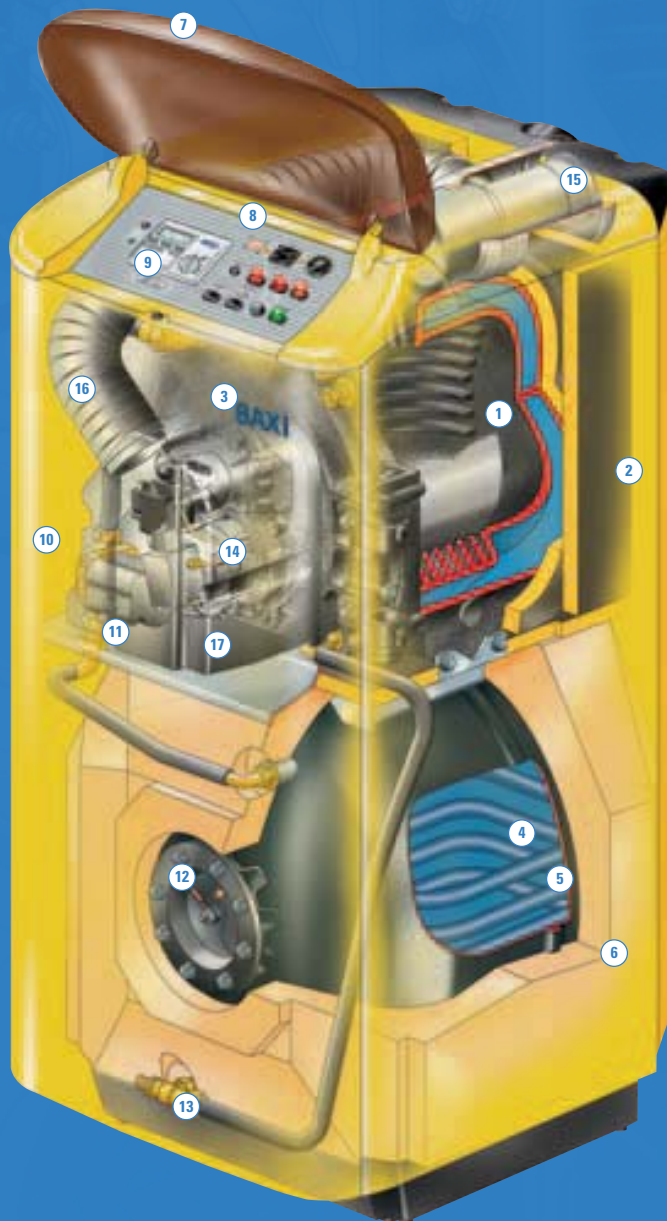

- 1 Cast iron one or two pieces hemispherical heat exchanger
- 2 Epoxy steel jacket
- 3 Incorporated burner
- 4 130/170 l hot water tank
- 5 Enamelled steel exchanger
- 6 CFC free polyurethane insulation
- 7 Translucent protective screen
- 8 Control panel
- 9 Detachable control unit
- 10 Soundproofed front
- 11 Domestic hot water load pump
- 12 Inspection flap
- 13 Drain cock
- 14 Flow separator
- 15 80/125 in and out stainless steel concentric conversion kit
- 16 Air hose
- 17 Sealed cover

INSTALLATION

GEODIS FAN FLUE INSTALLATION RULES

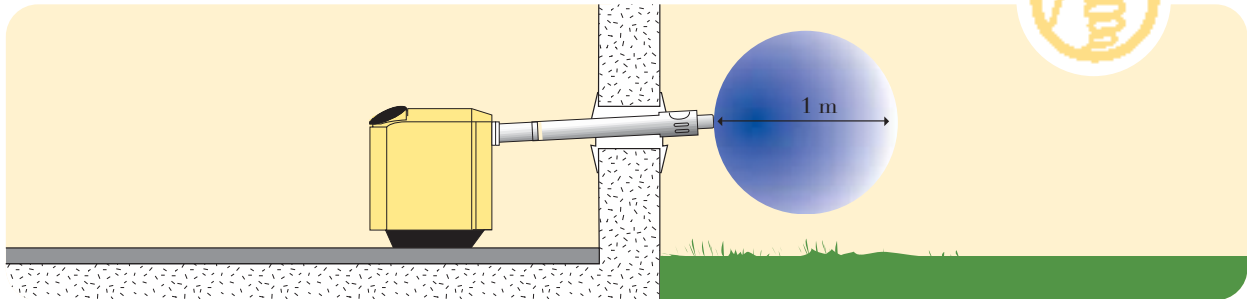

No obstacles shall be put in the dilution area to prevent combustion gas recycling risks.

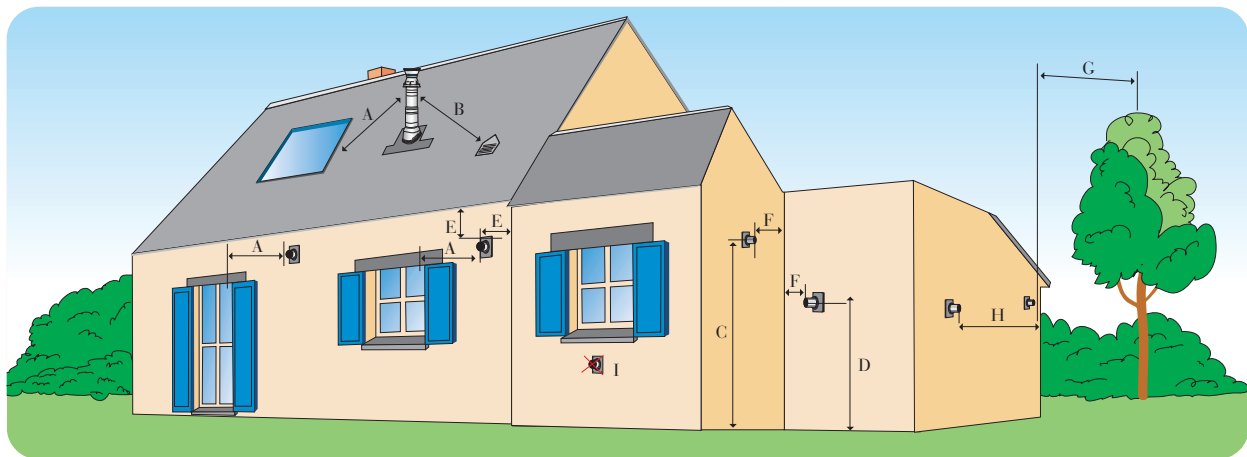

Dimensions shown originate from the flue gases extraction opening centreline.

- A: 1 m** - Minimum distance relative to any opening leaf.
- B: 1 m** - Minimum distance relative to any ventilation opening.
- C: 2 m** - Minimum height relative to the ground outside, when the opening opens out onto a public or private road.
- D: 0.50 m** - Minimum height relative to the ground, the flue gases exhaust opening shall then be protected by a grating provided for this purpose.
- E: 0.50 m** - Minimum height relative to a roof ledge, gutter or vertical piping.
- F: 2 m** - Minimum distance relative to a wall at 90°, with an opening leaf or ventilation.
- G: 2.50 m** - Minimum distance relative to a hedge or plantation.
- H: 3 m** - Minimum distance between two fan flue terminals.
- I:** The terminal cannot be installed under a window or balcony ledge.

WHAT SHOULD NEVER BE DONE

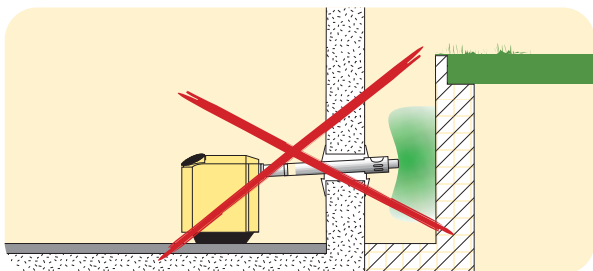

Fit a fan flue outlet opening out onto a closed or half closed area.

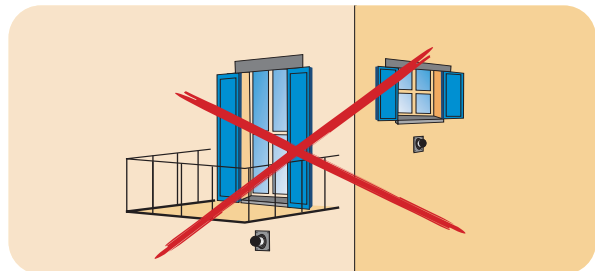

Fit a fan flue outlet under a window or balcony.



WHICH FAN FLUE PACKAGE SHALL WE CHOOSE?

■ Example of connections for fan flue boiler.

- | | | | |
|--|---------------|-----------------------------------|---------------|
| ① 350 to 650 mm adjustable horizontal terminal | Ref. FFVF0002 | ⑦ Condensate recovery device' | Ref. FFVF0007 |
| ② Vertical terminal | Ref. FFVF0013 | ⑧ Sound filter (option) | Ref. FFVF0008 |
| ③ 1000m extension | Ref. FFVF0003 | ⑨ Fan flue protective grille | Ref. FFVF0009 |
| ④ 500m extension | Ref. FFVF0004 | ⑩ 390 to 640 adjustable extension | Ref. FFVF0010 |
| ⑤ 90° bend | Ref. FFVF0005 | ⑪ 15 to 30° fillet | Ref. FFVF0011 |
| ⑥ Set of two 45° bends | Ref. FFVF0006 | ⑫ 30 to 45° fillet | Ref. FFVF0012 |
| | | ⑬ Slate fillet | Ref. FFVF0014 |

(1) One of these fittings is compulsory for GÉODIS FAN FLUE connection.

GÉODIS BVi horizontal outlet.

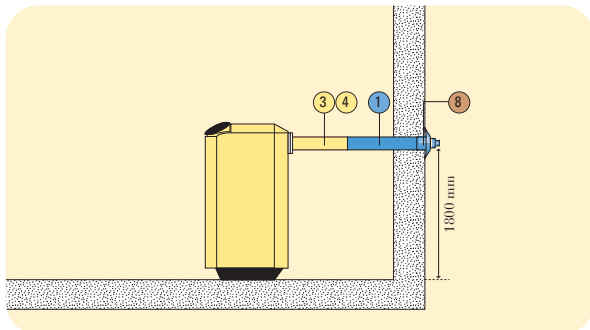

GÉODIS BVi vertical outlet.

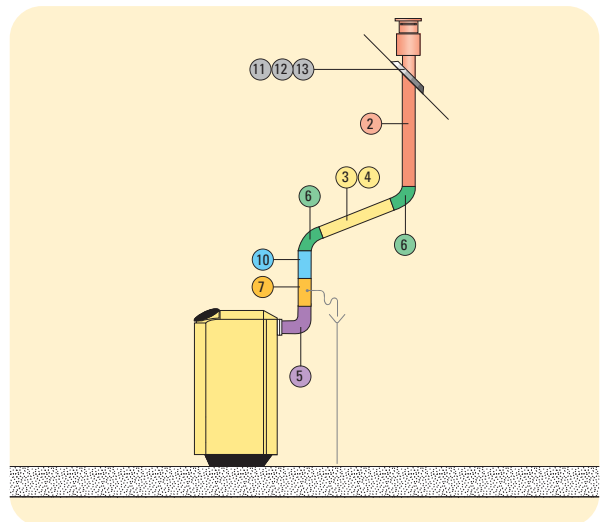

GÉODIS CVi raised horizontal outlet.

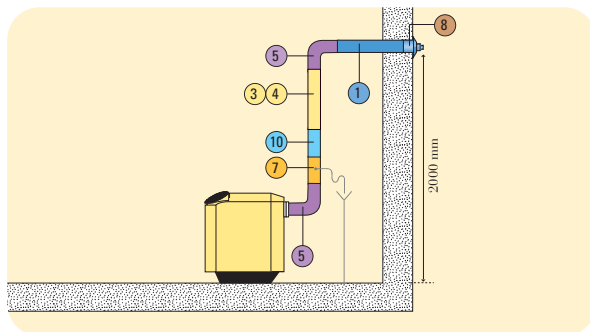

The outlet bend may be directed to the left or right horizontal position

GÉODIS BVi straight roof outlet.

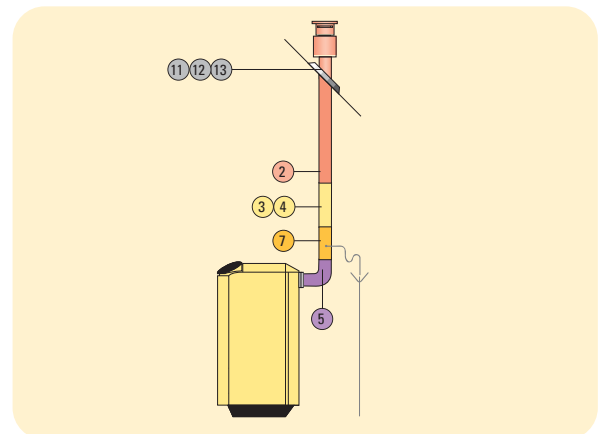

GÉODIS CVi straight wall outlet.

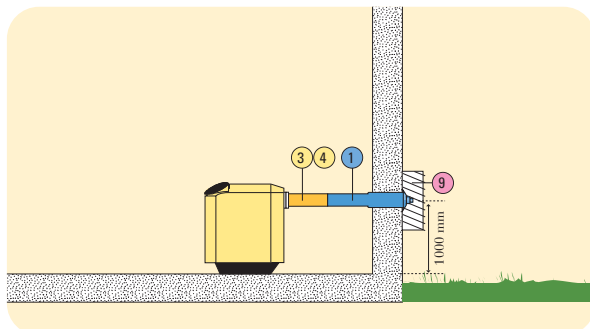

Maximum permitted length as equivalent straight length:

- 8m in vertical fan flue
- 4m in horizontal fan flue
- 1 90° bend = 1m – 45° bend = 0.5m

"PLUS" TECHNOLOGY MAKING THE DIFFERENCE

CONTROL PANEL

GEODIS control panels have very user friendly ergonomics. The display shows clearly the setting on the screen thanks to a text zone.

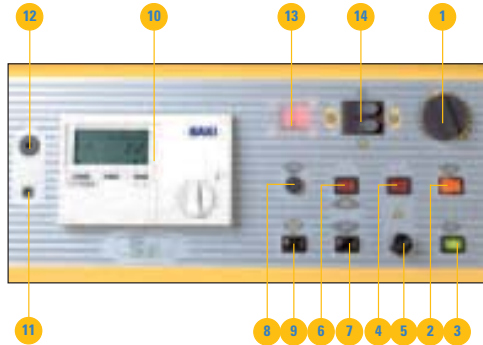

GEODIS Bi control panel.

- | | |
|---|--|
| <ul style="list-style-type: none"> 1 Boiler thermostat (for manual operation) 2 On indicator 3 On/off switch 4 Boiler safety indicator 5 Boiler safety thermostat reset 6 Burner safety indicator 7 Burner reset | <ul style="list-style-type: none"> 8 Fuse 9 Burner test switch 10 Control unit housing 11 Service switch 12 Service connector 13 Digital display 14 Manual / automatic switches |
|---|--|

COMFORT CONTROL UNITS

The GEODIS intelligence resides in its incorporated control unit. It provides users with an optimum comfort level. It can locate its control unit at the most practical place it considers: either leaving it on the boiler control panel, or in a living room on a pedestal supplied. Control units in living rooms control ambient temperature and users can remotely read or change all operating settings. A text zone is for clearly displaying the displayed setting which makes using it easier.

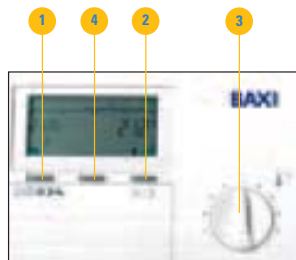

Control unit in operating position.

- | | |
|---|--|
| <ul style="list-style-type: none"> 1 Heating mode selection switch: <ul style="list-style-type: none"> Standby Programme Permanent comfort Permanent reduction Permanent DHW only | <ul style="list-style-type: none"> 2 Brief programme exemption switch 3 Comfort ambient temperature setting 4 Display screen for operating settings and setting |
|---|--|

ACCESSIBLE USER FUNCTIONS

- Outside temperature.
- Time.
- Day.
- Set comfort ambient temperature.
- Set reduced ambient temperature.
- Set tank temperature.
- Daily programme (3 periods/day).
- Holiday shut down programming.
- Technical function access.
- Standard programme.
- Measured hot water temperature.

INSTALLER SETTING FUNCTIONS

- Language (F, D, GB, FL, E).
- Bus address.
- Slope.
- Maximum output temperature.
- Auto-fitting.
- Ambience effect.
- Ambience calibration.
- Optimization.
- Legionnaires disease prevention (on, off).
- 24hr/24hr DHW mode as programme.
- Valve motor (time setting).

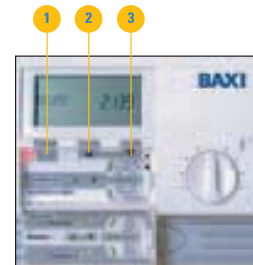

Control unit in operating position.

The open door of the control unit enables setting and display functions to be accessed. The and switches are for scrolling the menu, then when a change is wanted with the + switch light 1 goes on. The and switches are then used for changing settings. By pressing the switch the light goes out validating them.

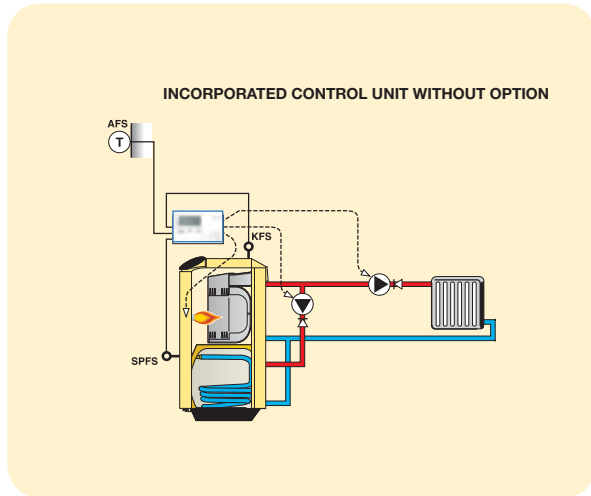

Direct heating circuit with domestic hot water production.

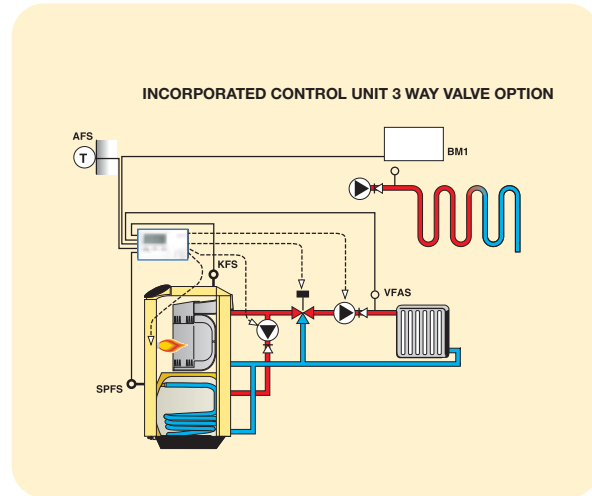

Heating circuit on mixer valves with domestic hot water production

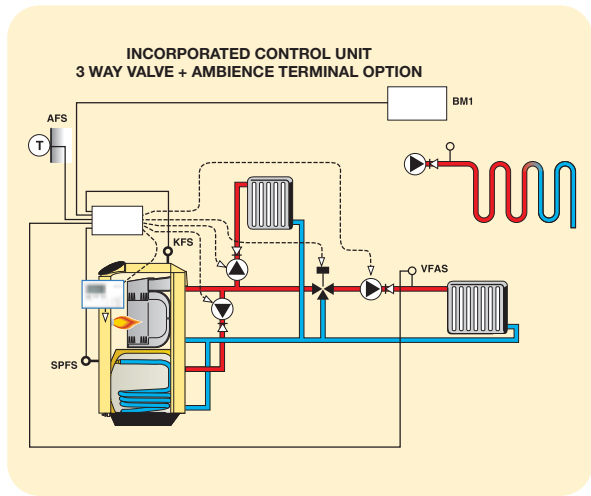

2 heating circuits with 1 on valve with domestic hot water production

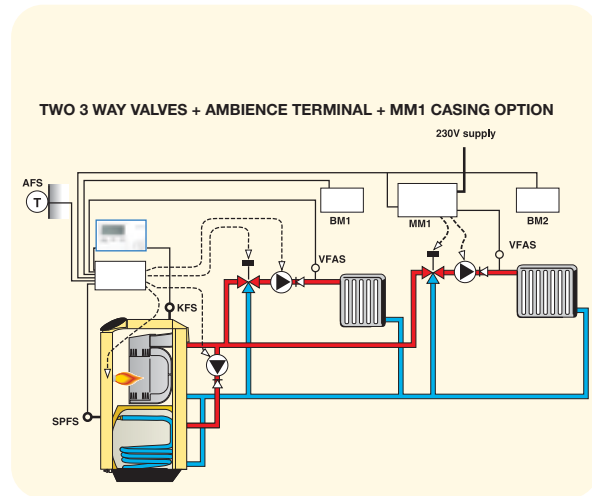

2 separate heating circuits on 2 valves with domestic hot water production

LEGEND: AFS. Outside sensor
SPFS. Hot water tank sensor
KFS. Boiler sensor

VFAS. Output sensor
BM1. 1st circuit control
BM2. 2nd circuit control

MM1. 2nd 3 way valve control module

FITTINGS AS OPTIONS



2nd circuit control unit.



MM1 module for 2nd 3 way valve control.



Telephone control.



3 way mixer valve with output sensor package.



Output sensor package.

HEATING MODULES: UNIVERSAL MODULES

BAXI offers a range of heating modules specially designed to make up comprehensive systems consistent with GEODIS boilers. Special tubing make it possible to fit these modules directly onto output/return connections on GEODIS boilers, on the right or left. The modules as well as the tubing are heat insulated.

■ 1. HEATING MODULE FOR CIRCUIT WITH NO MIXER VALVE (No. 12000201).

Purpose: for boilers with or without control unit directly regulating a burner for a radiator circuit.

Packaging: delivered in 1 package No. 12000201 (module 1).

Contents: One heating circulating pump, hot water output thermometer, hot water return thermometer, isolating valves, 1" internal Ø connection heat insulation.



Module 1

■ 2. HEATING MODULE FOR CIRCUIT WITH NO MIXER VALVE WITH DIFFERENTIAL VALVE (No. 12000202).

Purpose: for boilers with or without control unit directly regulating a burner for a radiator circuit. The differential valve balances the pressure in the event of the thermostat controlled valves on the radiator circuit being closed.

Packaging: delivered in 2 packages (1 module package No. 12000201 and 1 differential valve package No. 12000207).



Module 2

■ 3. HEATING MODULE FOR CIRCUIT WITH 3 WAY NON MOTORIZED VALVE (No. 12000203).

Purpose: for boilers with or without control unit directly regulating valve and burner for a radiator circuit or underfloor heating.

Packaging: delivered in 1 package No. 12000203 (module 3).

Contents: One heating circulating pump, hot water output thermometer, hot water return thermometer, isolating valves, 1" internal Ø connection heat insulation and 3 way non powered valve.



Module 3

■ 4. HEATING MODULE FOR CIRCUIT WITH 3 WAY NON MOTORIZED VALVE, DIFFERENTIAL VALVE (No. 12000204).

Purpose: for boilers with or without control unit directly regulating valve and burner for a radiator circuit with thermostat controlled valve or underfloor heating.

Packaging: delivered in 2 packages (1 module 3 package and 1 differential valve package No. 12000207).



Module 4

■ 5. HEATING MODULE FOR 2 CIRCUITS INCLUDING 1 ON 3 WAY NON MOTORIZED VALVE (No. 12000205).

Purpose: for boilers with control unit regulating 2 circuits, first radiator or underfloor heating circuit, second exclusively radiator circuit with differential valve. If it is a DHW production boiler 2 heating circuits can be produced with this module.

Packaging: delivered in 4 packages (1 module 1 package No. 12000201, 1 module 3 package No. 12000203, 1 manifold package No. 12000208 and 1 differential valve package No. 12000207).



Module 5



HEATING MODULES (CONTINUED)

6. HEATING MODULE FOR 2 CIRCUITS INCLUDING 2 NON MOTORIZED 3 WAY VALVES (No. 12000206).

Purpose: for boilers with control unit regulating 2 circuits regulating two 3 way valves.

Packaging: delivered in 4 packages (2 module 3 packages No.12000203, 1 manifold package No. 12000208 and 1 differential valve package No. 12000207).

Module 6



7. VALVE MOTOR WITH VFAS OUTPUT SENSOR (No. 12000209).

8. INSULATED CONNECTION TUBINGS (No. 12000187).

Purpose: for connecting the above modules. The insulated tubing is fitted on the left or right of the boiler. Option of connecting the safety module and expansion tank (not

supplied).

Packaging: delivered in 1 packaging

Valve motor with output sensor



9. SAFETY MODULE No. 12000212).

Purpose: The insulated module includes a safety valve, gas relief valve and pressure gauge. The safety module is fitted on the

insulated connection tubing. It cannot be separately fitted.

Safety module



FITTING

RIGHT FITTING

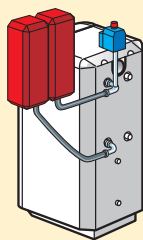

LEFT FITTING

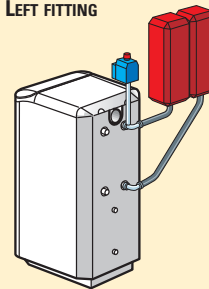

Connecting to Bi version GEODIS boilers.

"ECO HEATING MODULE" CONNECTION KIT

The ECO heating module, designed by BAXI combines all additional components of GEODIS for making complete quality installation in less time.

Function: module for heating circuit on motorized mixer valve, for fitting on right or left of boiler (option for connecting 2 modules on right or left).

Contents: pump, flap valve, motorized 3 way valve, valve, pressure gauge, 18 litre expansion tank, gas relief valve, isolation valve, compression connections, isolated connection pipes, insulating sleeves.



ECO module fitted on GEODIS.

DOMESTIC HOT WATER MODULE

BAXI offers a complete domestic hot water module absolutely appropriate to requirements for fast fitting to the GÉODIS hot water tank. The unit includes all functions required for making a quality installation: thermostat mixer, NF pollution preventing safety set, funnel, siphon, 8 l domestic hot water expansion tank, isolation valve, disconnection device, valve and NF filling disconnection device.

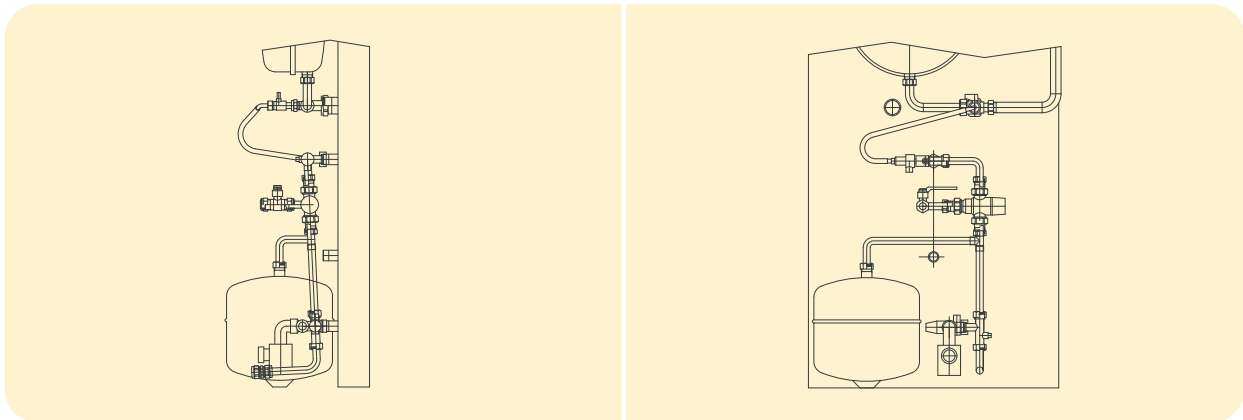

GENEROUS DOMESTIC HOT WATER COMFORT

The GÉODIS BVi and Bi versions incorporated 130/170 l tank provides outstanding domestic hot water performance: plentiful hot water at a stable temperature. Its 260/300 litres output in 10 minutes enables it to meet the needs of a large family or a high comfort level installation.

GÉODIS Bi / BVi	130 l	170 l
1 bath + washbasins – sinks	●	●
1 bath + 1 shower + washbasins - sinks	●	●
1 bath + 2 showers + washbasins - sinks	●	●
2 baths + washbasins - sinks	▲	●
2 baths + 1 shower + washbasins - sinks	▲	●

● OUTSTANDING ▲ POSSIBLE

DHW TANK SPECIFICATIONS ACCORDING TO RT 2000

Models		GÉODIS Bi				GÉODIS BVi		
		24 kW	30 kW	40 kW	50 kW	25 kW	35 kW	45 kW
Storage capacity	l	130	130	170	170	130	170	170
Heating surface	m ²	0.85	0.85	1.05	1.05	0.85	1.05	1.05
Storage temperature	°C	60	60	60	60	60	60	60
Draw off flow rate in 10 min*	l	260	260	300	300	260	300	300
Continuous draw off $\Delta T = 30K$	l/h	800	800	950	950	730	950	950
Pre-heating time	min	15	15	20	20	15	20	20
Nominal output**	kW	27.5	27.5	32	32	27.5	32	32
Max. operating pressure (domestic hot water)	bar	7	7	7	7	7	7	7
Auxiliary electric output	W	104	104	104	104	104	104	104

* According to EN 303.6 on Bi 30 model.

** Hot water 40°C, cold water 10°C.



HEATING: PERFORMANCE

HIGH ★★CE PERFORMANCE

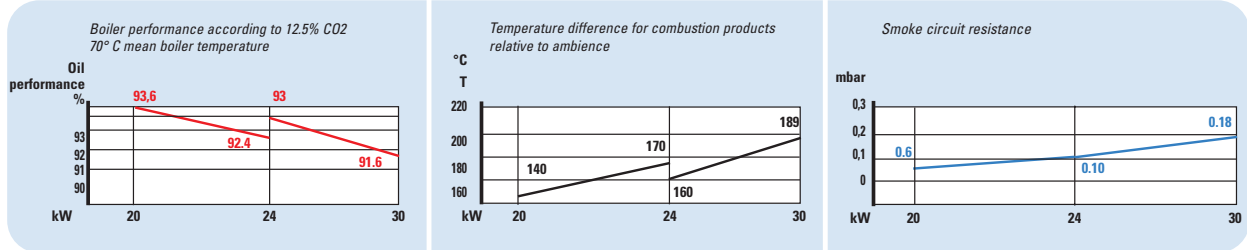

FEATURES OF PUMP COMMON TO ALL MODELS (3 POSSIBLE SPEEDS)

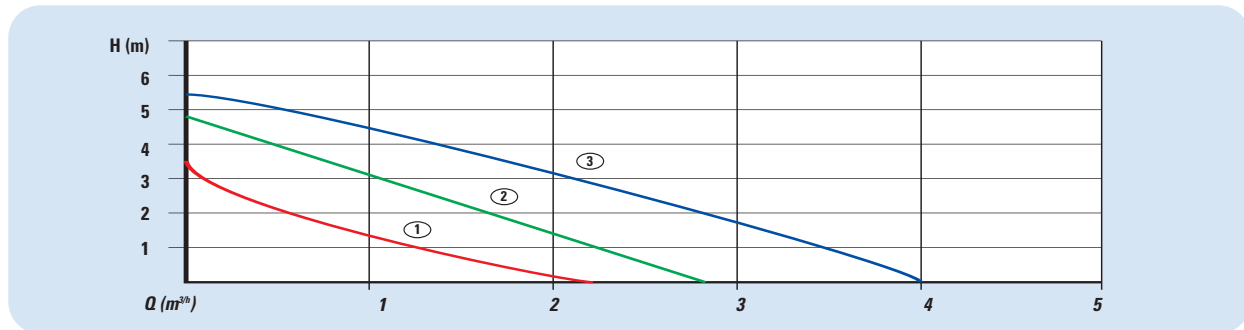

BOILER SPECIFICATIONS ACCORDING TO RT 2000

Models	GÉODIS Ci				GÉODIS Bi				GÉODIS CVi			GÉODIS BVi				
	24	30	40	50	24	30	40	50	25	35	45	25	35	45		
Type of generator	heating				mixed				heating			mixed				
Type of boiler	BT				BT				BT			BT				
Flue exhaust	chimney								suction							
Nominal output	kW		20/24	24/30	40	50	20/24	24/30	40	50	25	35	45	25	35	45
Heat output	kW		21.9/26.4	26.0/33.0	45.1	55	21.9/26.4	26.0/33.0	45.1	55	27.9	40.2	49	27.9	40.2	49
Flue gas discharge	kg/h		37	47	63	78	37	47	63	78	-	-	-	-	-	-
Flue gas volume	l		30	38	51	64	30	38	51	64	-	-	-	-	-	-
Smoke circuit resistance	mbar		0.1	0.18	0.18	0.3	0.1	0.18	0.18	0.3	-	-	-	-	-	-
Required draught	mbar		0.15	0.23	0.23	0.53	0.15	0.23	0.23	0.53	-	-	-	-	-	-
100% and 70°C load efficiency	%		91.4	90.2	90.5	90.5	91.4	90.2	90.5	90.5	89.6	90.5	90.5	89.6	90.5	90.5
30% and 30°C load efficiency	%		92	92.9	91	91	92	92.9	91	91	91.5	91	91	91.5	91	91
Losses when off Δ T = 30 K	W		182	182	300	300	252	252	420	420	182	300	300	252	420	420
Auxiliary electric output (burner)	W		80	80	80	80	80	80	80	80	80	80	80	80	80	80
Nominal water flow rate at Pn Δ= 20K	m³/h		1.37	1.7	2.3	2.8	1.37	1.7	2.3	2.8	1.4	1.9	2.4	1.4	1.9	2.4
Nominal flow rate boiler Δ P	mbar		3.3	5.3	10	12	3.3	5.3	10	12	3.6	9	11	3.6	9	11
Water content	l		24	32	30	30	24	32	39	39	24	30	30	32	39	39
Max operating pressure (primary)	bar		4	4	4	4	4	4	4	4	4	4	4	4	4	4
Test report reference	No.		997261	997261	-	-	997261	997261	-	-	2071230	-	-	2071230	-	-
Official testing laboratory	CETIAT															
EC Reference	49 AU 122R									49 BL 130R						

GEODIS

GEODIS Bi/BVi

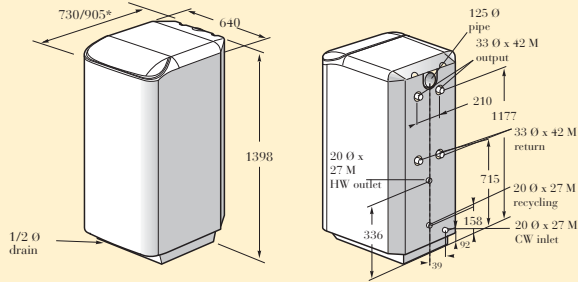

*For outputs > 30 kW

GEODIS Ci/CVi

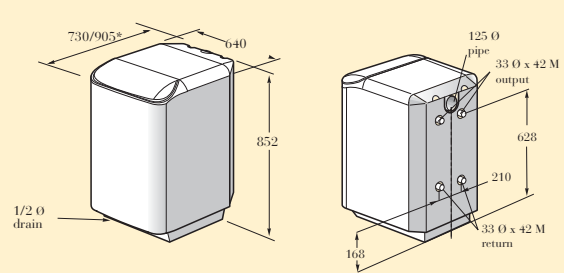

*For outputs > 30 kW

Geodis Models		Bi 24	Bi 30	Bi 40	Bi 50	BVi 25	BVi 35	BVi 45
Power	kW	24	30	40	50	25	35	45
Number of parts		one piece	one piece	2	2	one piece	2	2
Combustion chamber P depth	mm	337	337	475	475	337	475	475
Drain cock	mm	125	125	139	153	80/125	80/125	100/150
DHW tank capacity	l	130	130	170	170	130	170	170
Electricity supply		AC 230V-50hz						
Packaged weight	Kg	270	270	364	364	272	366	366
Net weight	Kg	230	230	314	314	232	316	316

Geodis Models		Ci 24	Ci 30	Ci 40	Ci 50	CVi 25	CVi 35	CVi 45
Power	kW	24	30	40	50	25	35	45
Number of parts		one piece	one piece	2	2	one piece	2	2
Combustion chamber P depth	mm	337	337	475	475	337	475	475
Drain cock	mm	125	125	139	153	80/125	80/125	100/150
Electricity supply		AC 230V-50hz						
Packaged weight	Kg	215	215	278	278	212	281	281
Net weight	Kg	180	180	239	239	180	242	242

GEODIS		SUPPLIED ▲ Standard ● Option
Ci/CVi	Bi/BVi	
GENERAL SPECIFICATIONS		
▲	▲	• Cast iron (≤ 30 kW) or two pieces (> 30 kW) heat exchanger fitted with combustion chamber channel.
▲	▲	• Yellow lacquered steel jacket with sound insulation fitted
▲	▲	• Heat exchanger glass wool insulation
▲	▲	• Control panel with automatic control unit: - remote control - outside sensor - DHW sensor (delivered not fitted on Ci version)
▲	▲	• Incorporated 500 i ecological burner fitted and factory preset
▲	▲	• Domestic hot water tank fully fitted and factory connected
▲	▲	• Domestic hot water load pump
▲*	▲*	• Delivery in 1 package on pallet (unit fully factory assembled)
▲*	▲*	• 80/125 in and out stainless steel concentric suction connection conversion unit
▲*	▲*	• Sealed burner cover
FITTINGS		
▲	▲	• Sweeping brush
▲	▲	• Fitted drain cock
▲	▲	• Base with adjustable feet
▲	▲	• 2 heating outputs, 2 heating returns 33/42 Ø threaded
▲	▲	• Burner time switch on control panel
OPTIONS		
●	●	• MT 31 telephone control
●	●	• 1 to 6 heating modules and ECO module
●	●	• Ambience module for 2 nd BM circuit
●	●	• Control for 2 nd 3 way MMI valve
●	●	• Safety module
●	●	• Domestic hot water module
●	●	• Roll on – roll off kit
●*	●*	• All suction connection fittings

* For fan flue models

BAXI

157, AVENUE CHARLES FLOQUET
93158 LE BLANC-MESNIL CEDEX - FRANCE
TÉLÉPHONE : + 33 (0) 1 45 91 56 00
FAX: + 33 (0) 1 45 91 56 18
www.baxifrance.com

BAXI S.A.

LIMITED COMPANY WITH 43 214 640 EURO CAPITAL
R.C.S. BOBIGNY B 602 041 675 - A.P.E. 282D
A member of BAXI GROUP LTD

