









Plenum boxes

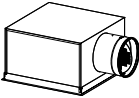

About Lindab	1
Comfort and Design	2
Product overview / symbols	3
Theory	4
Ceiling diffusers	5
Ceiling diffusers - visible	6
Plenum boxes	7
Wall diffusers	8
Nozzles	9
Ventiduct	10
Grilles	11
Displacement diffusers	12
VAV	13
Air flow regulators	14
Air valves	15
Fresh air valves/overflow units	16
Cleanroom diffusers	17
Contents	18

Plenum boxes

Plenum boxes

	Product	Functions	Page
1			
2			338
3			
4			340
5			341
6			342
7			
8			
9			
10			
11			
12			
13			
14			
15			
16			
17			
18			

Plenum boxes



Plenum box type H

Plenum boxes

Plenum boxes are used for supply and exhaust of air through diffusers and grilles. The plenum box ensures a continuous flow to the diffuser, and plenum boxes equipped with dampers create the possibility of adjusting the diffuser on an individual level. Furthermore, the plenum box is usually supplied with acoustic insulation. This contributes to the sound attenuation inside the box. This way the noise from the air flow inside the air duct system and the sound from room to room is reduced.

Large selection

Lindab's selection of plenum boxes include plenum boxes for mounting in ceiling or wall/skirt. The plenum boxes are normally delivered with dampers and measuring devices in addition to acoustic insulation. The plenum boxes are equipped with a scaled adjustment wire with a lock-function where the K-factor is independent of the diffuser. The K-factors are printed on the adjustment wire. The plenum-boxes eliminate the need for a straight air duct in front of the diffuser, which gives a greater flexibility in mounting.



MBB box



Описание

MVB расширительная камера для приточных и вытяжных диффузоров, служит для достижения стабильного расхода воздуха через диффузор, измерения расхода, балансировки системы и снижения шума от вентиляционной системы.

MVB первая расширительная камера с уникальной конической заслонкой, позволяющей осуществлять регулировку по расходу в диапазоне от 0% до 100%, и держать высокое аэродинамическое сопротивление на камере практически не генерируя лишних шумов. Более того, конструкция заслонки способствует более точной и аккуратной настройке, нежели стандартный вариант заслонки.

MVB имеет шкалу настройки K-фактор и может быть преднастроен до окончательной пуско-наладки.

Камера MVB имеет маленький размер, что упрощает монтаж и использование.

- Может держать большое сопротивление при малой генерации шума
- Точные измерения
- Регулировка расхода в полном диапазоне (0-100%)
- Легко адаптируется к изменениям системы
- Простой монтаж и балансировка
- Маленькие размеры

Код Заказа

Изделие	MVB	aaa	bbb	c
Тип	MVB			
Соединение воздуховода $\varnothing d_1$	Ш100-315			
Соединение диффузора $\varnothing d_2$	$\varnothing 100-400$			
Описание	S = Приток E = Вытяжка			

Пример: MVB-100-160-S

Размеры

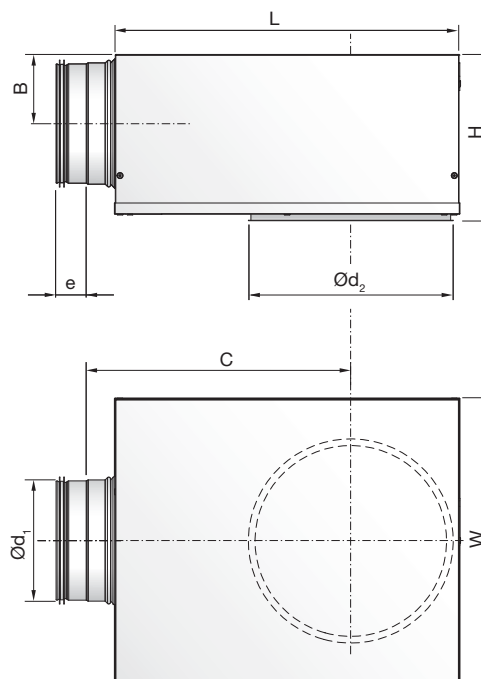

$\varnothing d_1$	$\varnothing d_2$	W	H	B	C	e	L	m
ii		ii						ëã
100	100	260	163	62	245	40	310	2,6
100	125	260	163	62	245	40	310	2,6
100	160	260	163	62	245	40	310	2,6
125	125	310	188	75	291	40	376	3,7
125	160	310	188	75	291	40	376	3,7
125	200	310	188	75	291	40	376	3,7
160	160	380	222	92	352	40	459	5,5
160	200	380	222	92	352	40	459	5,5
160	250	380	222	92	352	40	459	5,5
200	200	460	263	112	425	40	565	7,3
200	250	460	263	112	425	40	565	7,3
200	315	460	263	112	425	40	565	7,3
250	250	540	313	137	514	60	698	10,6
250	315	540	313	137	514	60	698	10,6
250	400	540	313	137	514	60	698	10,6
315	315	540	378	170	675	60	858	13,5
315	400	540	378	170	675	60	858	13,5

Обслуживание

Клапан может быть демонтирован для легкой очистки воздуховода.

Материалы и покрытие

Материал: Оцинкованная сталь
Стандартный цвет: Оцинкованная сталь

Возможна покраска в другие цвета. Пожалуйста обратитесь в Lindab для получения дополнительной информации.

Технические данные

Шумопоглощение

Шумопоглощение MVB + диффузор ΔL , включая концевое отражение, см. таблицу ниже.

Пример в таблице: PCA + MVB

MVB		Среднегеом. частоты октавных полос Hz							
$\varnothing d_1$	$\varnothing d_2$	63	125	250	500	1K	2K	4K	8K
100	100	18	17	8	20	19	20	19	23
100	125	19	16	7	19	18	18	18	21
100	160	21	16	5	15	17	18	16	19
125	125	18	13	9	20	13	19	18	19
125	160	12	13	8	19	13	16	17	19
125	200	16	11	5	16	13	15	15	17
160	160	17	17	11	19	18	17	20	20
160	200	14	14	7	21	15	16	18	19
160	250	15	15	5	17	13	15	16	18
200	200	15	10	6	16	17	15	19	18
200	250	12	9	5	14	17	15	17	17
200	315	12	7	4	11	15	14	16	15
250	250	14	8	8	14	16	17	17	18
250	315	12	6	6	15	15	15	16	17
250	400	13	5	4	13	14	14	15	15
315	315	7	9	8	14	17	16	17	21
315	400	7	8	8	12	16	16	16	18

Для других диффузоров + MVB:
Найдите модель диффузора в каталоге Комфорт. В технических данных приведены значения шумопоглощения диффузор + MVB.

Регулятор

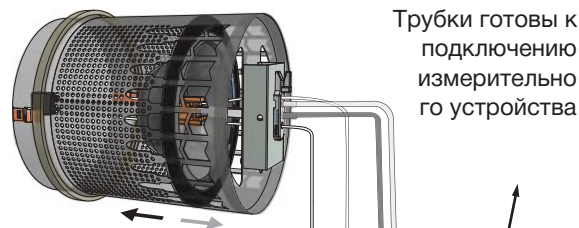
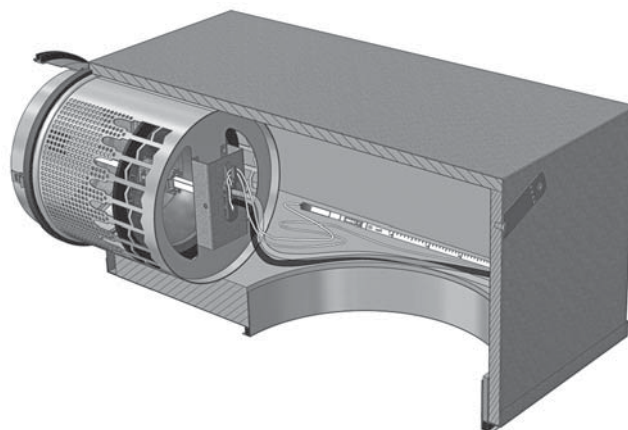

Заккрыть клапан

Тяните для регулировки клапана

Открыть клапан

Значение k-фактор на шкале.

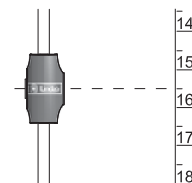

Дополнительные данные смотри на www.lindab.ru, монтажная инструкция MVB.



Dimensions

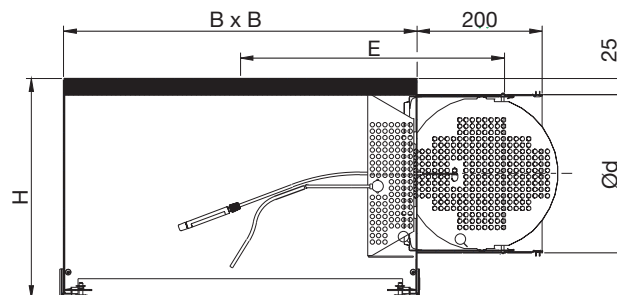

Description

The type H plenum box is a side-connected plenum box for supply and exhaust air for the Versio range of diffusers. The plenum box can be equipped with an adjustment damper and a measuring device, depending on the configuration required.

The adjustment damper is operated from the front of the box by means of a graduated handle with integral lock function.

K-factors for determining the volume flow are printed on the damper handle. The plenum box has a low overall height and has internal sound insulation of fibre-free material.

For configuration with an integrated ceiling solution, the box is equipped with a frame and/or a face plate, depending on the type of ceiling. For further details, see the Versio range of ceiling diffusers.

- Can be used for both supply and exhaust air.
- Can be connected regardless of straight ducting before the box
- Detachable damper and plenum plate for access to duct
- The same box is used for all face plates and ceiling systems

Maintenance

The damper can be removed in connection with cleaning of the internal parts or the duct.

Ordering information

Go to chapter: " ceiling diffusers - Versio "

Size	Ød mm	B mm	E mm	H mm
125	125	380	350	215
160	160	380	350	250
200	200	460	390	290
250	250	560	420	340
315	315	560	420	405

Materials and finish

The box, plenum plate and damper are made of hot-galvanised steel plate. Acoustic insulation is made of non-flammable material.



Description

VBA is a plenum box for supply and exhaust air intended to achieve a stable flow to a rectangular grille or other types of face plates. VBA is equipped with an adjustment damper and pressure measurement device. The plenum box can be connected from the side, the top or the back. The adjustment damper is operated from the front of the box by means of a graduated handle with integral lock function.

VBA is equipped with a telescopic connection for easy installation. The same face plate and telescope are used as for WB boxes.

- Can be used for both supply and exhaust air
- Easy-to-detach face plate for access to duct
- Same box used for all front types

Materials and finish

Box, plenum plate and damper are made of hot-galvanised steel plate.

Ordering example

Product		VBA	a	bbb	ccc
Type					
Connection	back	1			
	side	2			
	top	4			
A-Measure					
B-Measure					

Dimensions

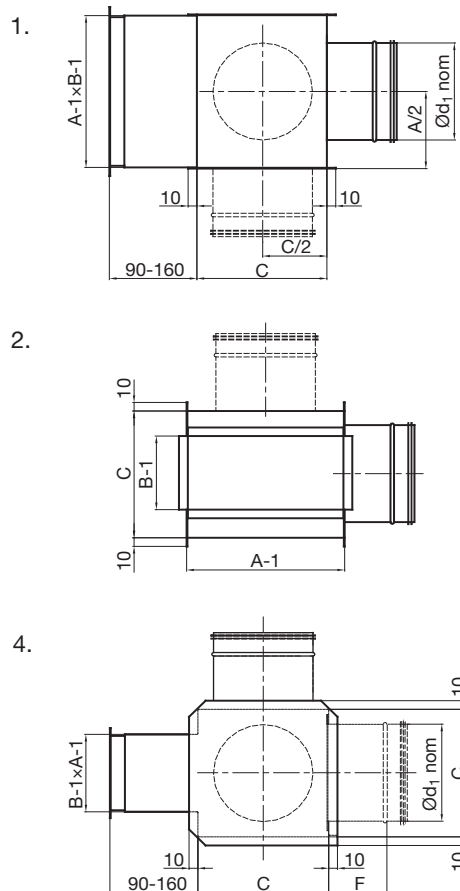

A x B	Ød ₁ nom	C mm	F mm
200 x 100	125	165	90
300 x 100	160	200	110
400 x 100	160	200	110
500 x 100	200	240	130
600 x 100	250	290	155
800 x 100	250	290	155
1000 x 100	250	290	155
300 x 150	200	240	130
400 x 150	250	290	155
500 x 150	250	290	155
600 x 150	250	290	155
800 x 150	315	355	190
1000 x 150	315	355	190
300 x 200	250	290	155
400 x 200	250	290	155
500 x 200	315	355	190
600 x 200	315	355	190
800 x 200	315	355	190
1000 x 200	315	355	190
600 x 300	400	440	215

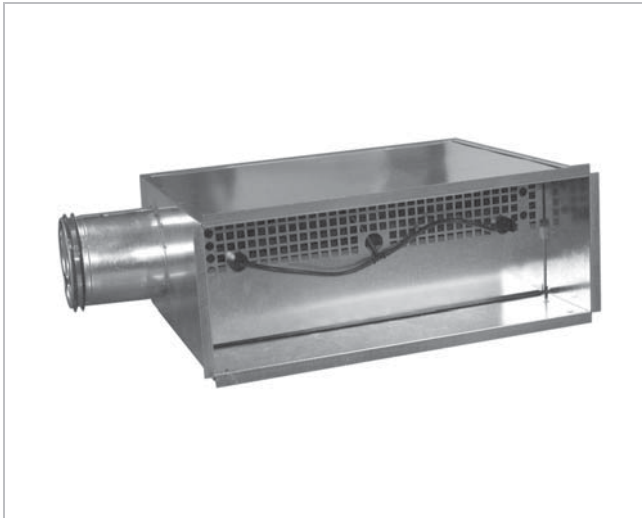

Description

WB is a plenum box for supply air intended to achieve a stable flow to rectangular front plates or grilles. WB is equipped with an adjustment damper and pressure measuring device. The plenum box can be connected from the side or the back. The adjustment damper is operated from the front of the box by means of a graduated handle with integral lock function. WB is equipped with a telescopic connection that can be adjusted up to 50 mm, which provides flexibility during the installation phase. WB has a maximum width of 500 mm, which ensures that you can install the box in a standrd wall structure with a centre distance of 600 mm between the plasterboard struts.

- Telescopic function
- Easy-to-detach face plate for access to duct
- Same box used for all front types

Materials and finish

Box, plenum plate and damper are made of hot-galvanised steel plate.

Order details

See section on wall diffusers.

Dimensions

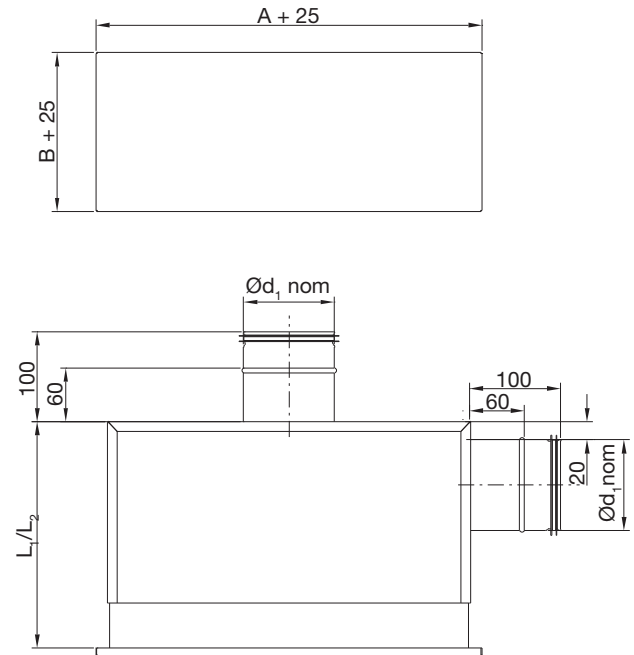

A x B	Ød ₁ nom	A	B	Back L ₁	Side L ₂	Weight Kg
300 x 100	80	300	100	240-290	280-330	2,5
400 x 150	100	400	150	240-290	300-350	3,5
500 x 150	125	500	150	240-290	325-375	4,3
500 x 200	160	500	200	240-290	360-410	5,5
500 x 300	200	500	300	240-290	400-450	7,4