

Model NDFL100-38 fully automatic dual fuel burner (MPA22 / RWF40).

Worcester Hospital Contract BR003211



Natural Gas / Class D Oil

Contents

IMPORTANT - SAFETY	4
EMERGENCY INSTRUCTIONS	4
EUROPEAN BOILER EFFICIENCY DIRECTIVE (B.E.D.)	4
IMPORTANT NOTICE	4
BURNER & COMPONENT IDENTIFICATION	5
COMBUSTION HEAD DETAILS	6
SETTING THE IGNITION ELECTRODES	6
CONTROL PANEL & ELECTRICAL DATA	7
BURNER WIRING DIAGRAM	8
FEATURES	15
Air Regulation	15
Controls & Operation	15
Fuel	15
GENERAL	15
SERVICES & SITE CONDITIONS	15
Gas Supply	15
Fuel Oil Storage and Handling	15
Fuel Oil Supply	15
Gravity feed system	15
Suction lift System	15
Flue and Chimney Requirements	15
Plant Room Ventilation	16
Existing Appliances	16
Combustion Chamber Conditions	16
ASSEMBLY	16
INSTALLATION	16
General	16
Fitting to the Appliance	16
Electrical Power Supply	16
BURNER AIR CONTROLS	16
Air Diffuser	16
Air Pressure Switch	16
BURNER GAS CONTROLS	16
Gas Nozzle	16
Gas Pressure Switch	16
INTEGRATED VALVE PROVING SYSTEM	16
Functional sequence	17
BURNER OIL CONTROLS	17
Oil Nozzle	17
Oil Control Train	17
MPA 22 CONTROL UNITS	17
Entering the pass code	17

NDFL - GAS	17
OPERATION	17
COMMISSIONING THE BURNER	18
MULTI-FUNCTIONAL DISPLAY	18
Check for Valve Closure	18
Gas Supply Pressures	18
ESTABLISHING MAIN FLAME	19
General Notes	19
Commissioning Procedure	19
Firing the burner	19
FINAL ADJUSTMENTS	20
Setting the Air Pressure Switch	20
Checking the Flame Signal	20
Setting the Low Gas Pressure Switch	21
FINAL CHECK	21
Commissioning is now complete	21
THE LANDIS & STAFA MODULATION CONTROLLER, TYPE RWF 40	21
Basic display	21
To change the working set point.	21
To enter a new parameter	22
NDFL - OIL	22
OPERATION	22
Three Nozzle System	22
COMMISSIONING THE BURNER	22
ESTABLISHING MAIN FLAME	23
Commissioning Procedure	23
Initial Settings Air Damper	23
Firing the burner.	24
SAFETY CHECKS	24
FINAL CHECK	24
MPA DISPLAYS	25
Standby Display	25
Operating Display	25
Information Display	25
Service Display	26
ROUTINE SAFETY CHECKS	26
Flame Detection System (UV Cell)	26
Flame Detection System (Photocell)	26
ROUTINE MAINTENANCE	27
Combustion Air Fan	27
Inner Assembly	27
Air Diffuser and Gas Nozzle	27
Ignition Electrodes	27

Oil Nozzles	27
Filters	27
Fan Motor	27
Replacement of Control Valve SKP20	27
FAULT FINDING	27
MPA Error Codes	27
Incorrect Rotation of Burner Motor	28
Burner Motor Fails to Start	28
Motor starts but burner will not light	28
Burner Fails to Establish Main Flame Gas firing only	28
Unstable pump pressure Oil firing only	28
Burner fires then locks out Oil firing only	28
Burner fails change to high flame Oil firing only	28
Flame failure in changing to high flame Oil firing Only	29
Burner fails change to low flame Oil firing only	29
Burner locks out without attempting to light	29
SPARE PARTS	29
BURNER SERVICE RECORD	32
NOTES	34

IMPORTANT - SAFETY

It is essential that qualified engineers who are experienced in forced draught gas and pressure jet oil burner commissioning carry out the following instructions and adjustments. In the UK it is a legal requirement that anyone working on gas installation, as defined in the "Gas Safety (Installation & Use) Regulations 1994" is CORGI registered. The manufacturer cannot be held responsible for any consequential damage, loss or personal injury as a result of failure to follow these instructions, or as a result of misuse.

EMERGENCY INSTRUCTIONS

This product has been designed and constructed to meet all of the essential requirements of the GAS APPLIANCE DIRECTIVE 90/396/EEC and other applicable European Directives. Under normal circumstances this product should not give occasion to any hazardous conditions. If such a condition should occur during commissioning or subsequent use of this product, be it a fault of the burner, the appliance or of any instrument, machine or service in the proximity of the burner, then the **FUEL** and **ELECTRICITY** supply to the burner should be **IMMEDIATELY ISOLATED** until such time that the fault has been investigated and rectified.

EUROPEAN BOILER EFFICIENCY DIRECTIVE (B.E.D.)

All burners and boiler bodies marketed separately within the European Union must comply with EN676 Gas Burners, EN267 Oil burners and EN303 Heating Boilers. Burner adjustments must be made in accordance with boiler manufactures instructions, and these must include flue gas temperatures, average water temperature, and CO₂ or O₂ concentration.

IMPORTANT NOTICE

To protect the microprocessor fitted in the MPA control units, any action such as the fitting or removal of plugs, valves or any other wiring should be carried out with the MPA isolated. Failure to comply with this notice may result in damage.

BURNER & COMPONENT IDENTIFICATION

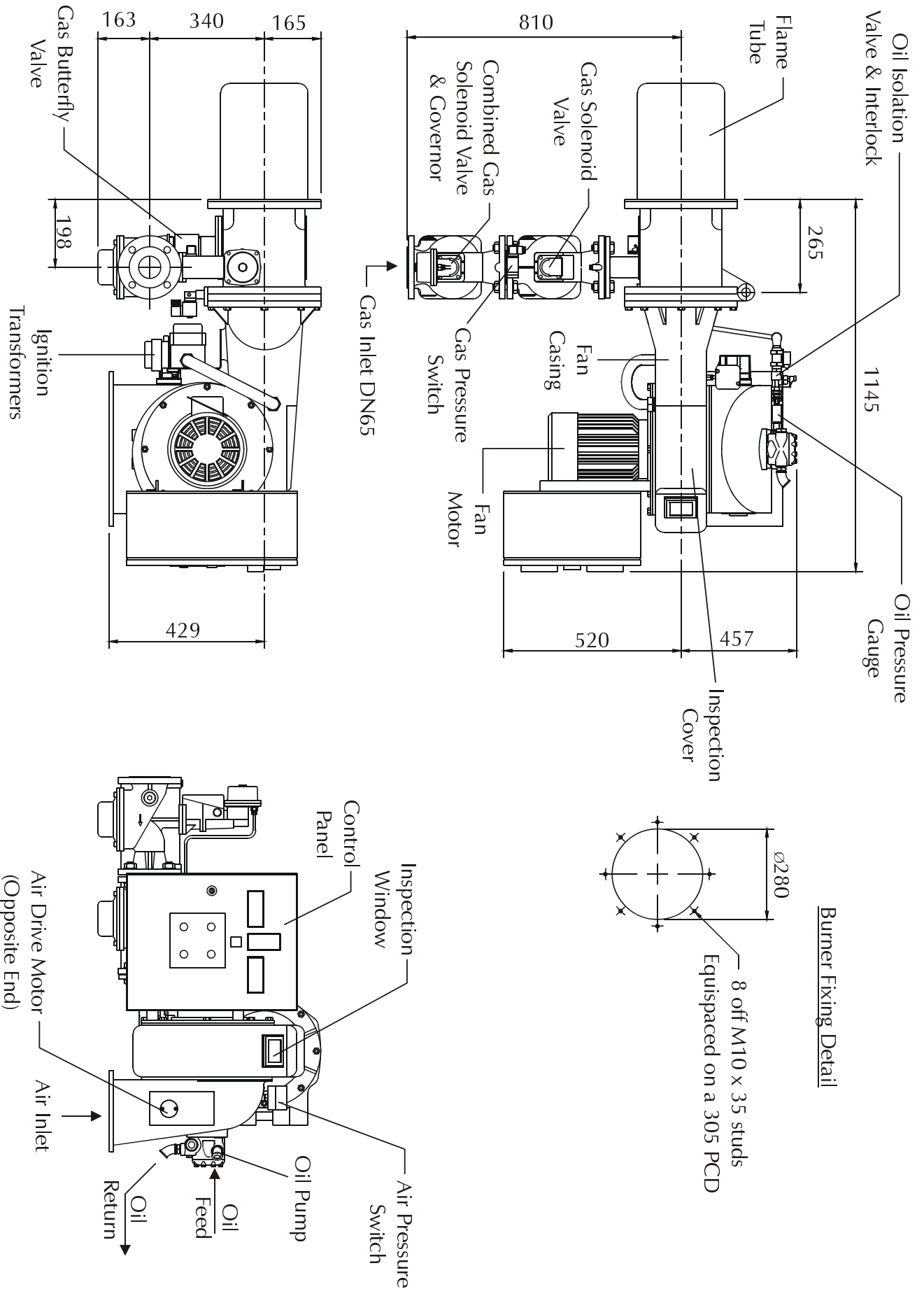

COMBUSTION HEAD DETAILS

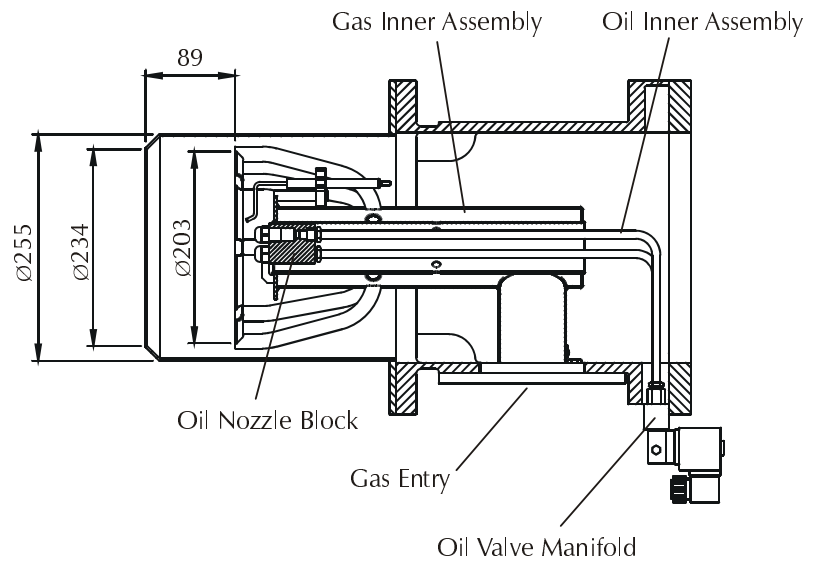
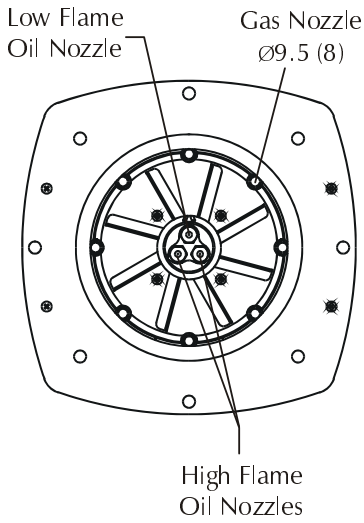
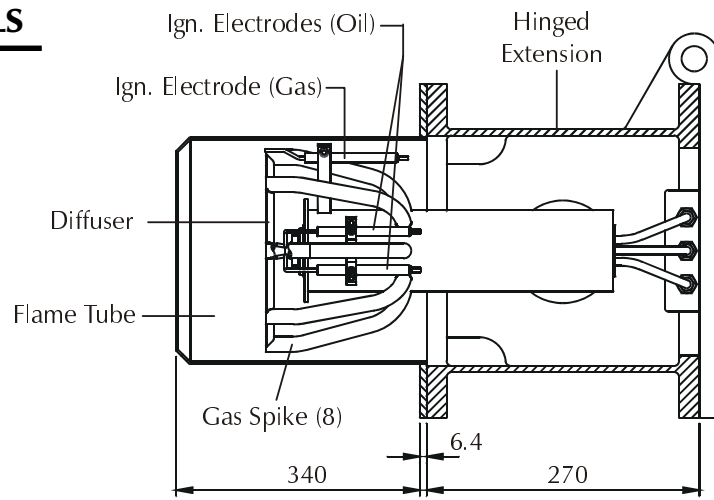

SETTING THE IGNITION ELECTRODES

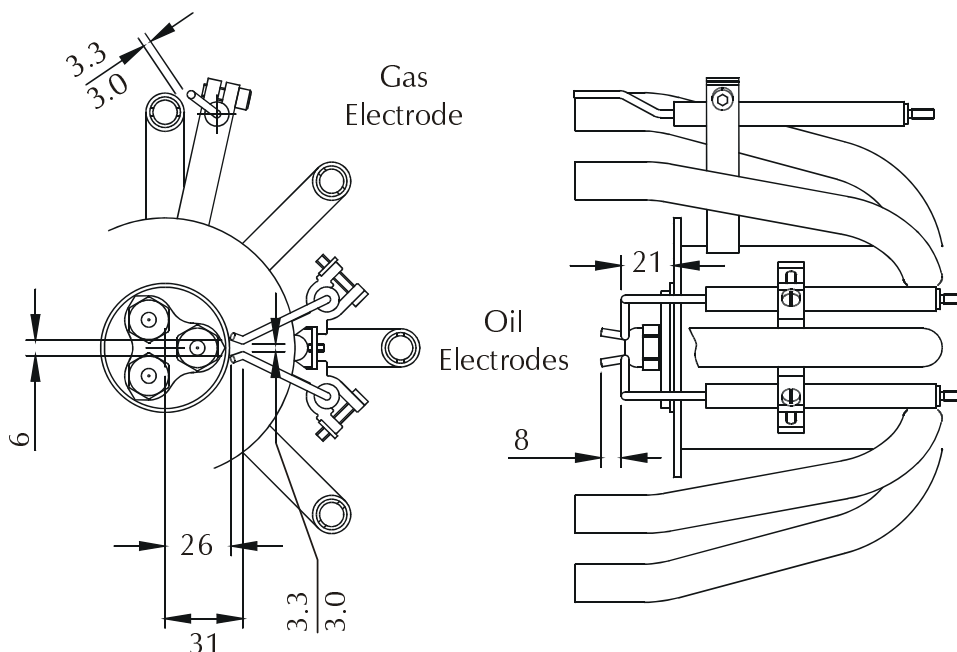

CONTROL PANEL & ELECTRICAL DATA

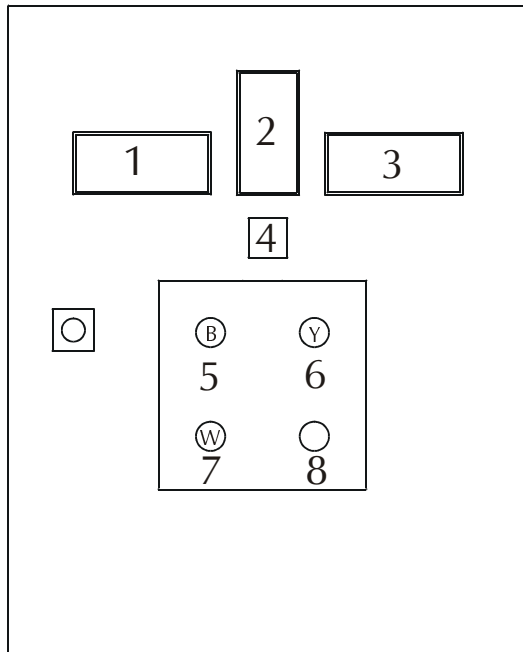

Panel Door

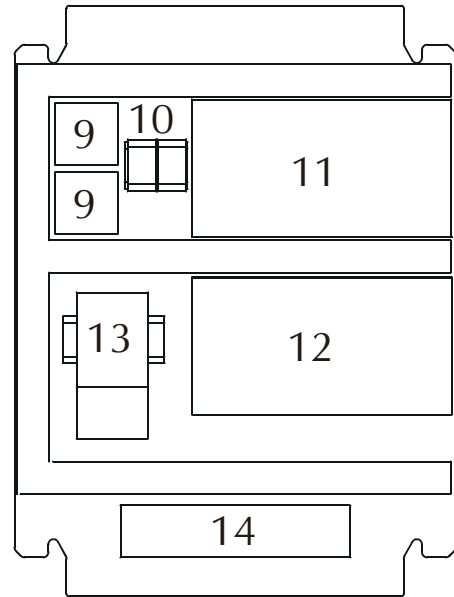

Panel Chassis

Item	Description	Item	Description
1	MPA22 Display (Gas)	8	Burner On/Off Switch
2	RWF40 Modulating Control	9	EMC Filters
3	MPA22 Display (Oil)	10	Relays
4	Fuel Selector Switch	11	MPA22 Control (Gas)
5	Gas Indicator Lamp	12	MPA22 Control (Oil)
6	Oil Indicator Lamp	13	Burner Fan Starter
7	Burner On Indicator Lamp	14	Main Terminals

3 Phase 400V/50Hz					
Burner Model	Motor (kW/rpm)	Start Current (A)	Full Load Current (A)	Main Fuse (A)	Cable Size (mm ²)
NDFL100-38	7.5/2800	57	15.2	40	4.0

BURNER WIRING DIAGRAM

REVISIONS		CONDITIONS OF USE	
REF	DATE	ACTION	
<p>READ FROM LEFT TO RIGHT</p> <p>ALL WIRING 0.5mm TRI-RATED UNLESS OTHERWISE STATED.</p> <p>PANEL WIRING _____</p> <p>EXTERNAL WIRING _____</p>			<p>THIS IS A SPECIAL COPY ISSUED TO _____ ON _____</p> <p>IT WILL NOT BE KEPT UP TO DATE AND SHOULD BE RETURNED TO</p> <p style="text-align: center;">NU-WAY DRAWING OFFICE</p>
<p>NU-WAY LIMITED, P.O. BOX 1, VINES LANE, DROITWICH, WORCESTERSHIRE, WR9 8NA, ENGLAND.</p> <p>TELEPHONE: (01905) 794331 & 794242 FACSIMILIE: (01905) 794017</p>			<p>TITLE</p> <p>CONN'S. FOR NDFL100-38 MOD. GAS 3 STAGE OIL DUNGS MPA 22 & SIEMENS RWF40 CONTROLS. (3PH)</p>
<p>FUSE REF</p> <p>F1</p> <p>F2</p>			<p>AMPAGE</p> <p>6.3A</p> <p>1A</p>
<p>PROTECTING</p> <p>CONTROL CIRCUIT</p> <p>MODULATING CONTROL</p>			<p>DATE</p> <p>15-2-00</p>
<p>DRAWN BY</p> <p>T.H.</p>			<p>DATE</p>
<p>CHECKED BY</p>			<p>DRAWING No.</p> <p>WE-0723</p>
<p>ISSUE</p> <p>0</p>			<p>PAGE</p> <p>1 OF 7</p>



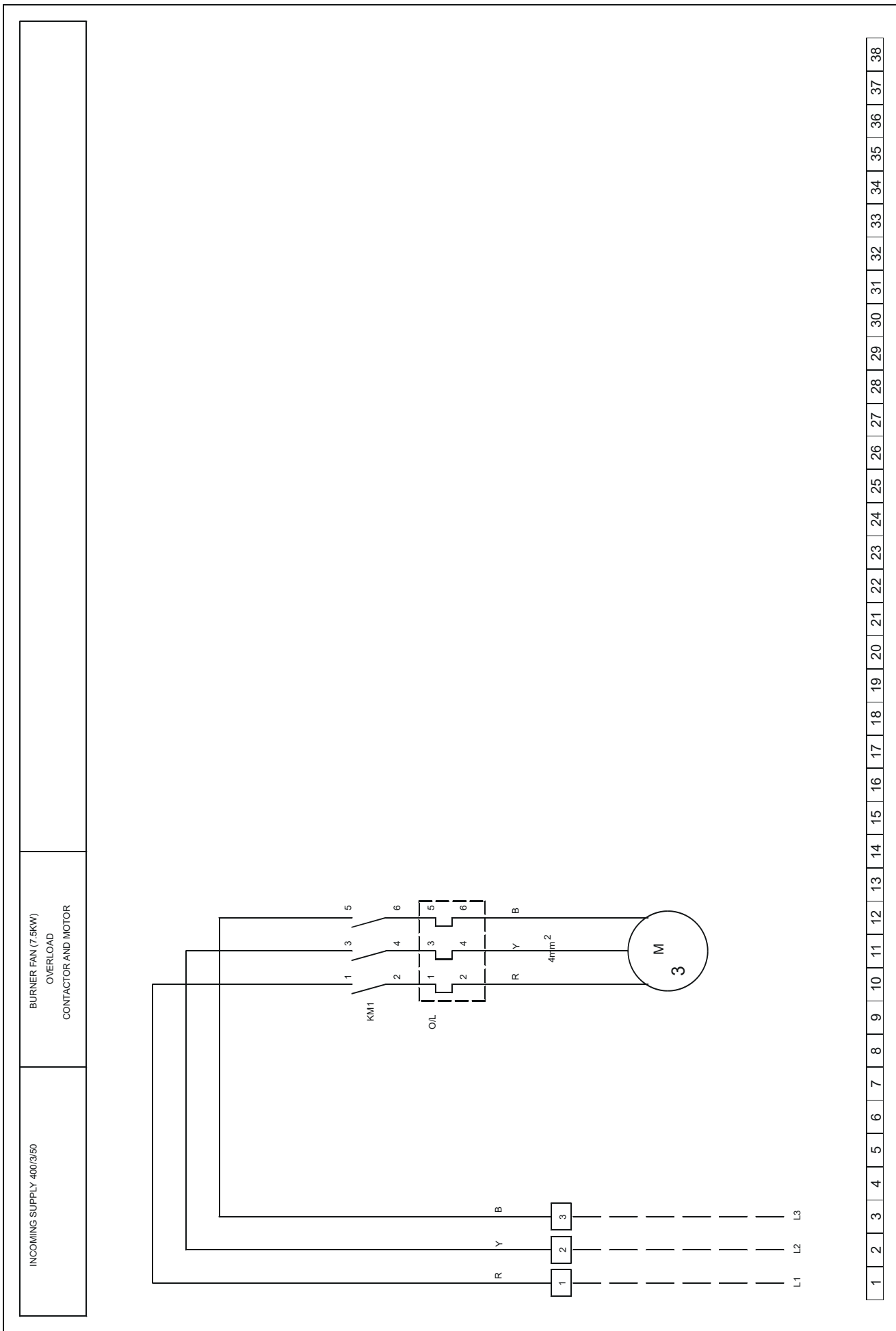

INCOMING SUPPLY 400/3/50

BURNER FAN (7.5KW)
OVERLOAD
CONTACTOR AND MOTOR

see page 1 for conditions of use

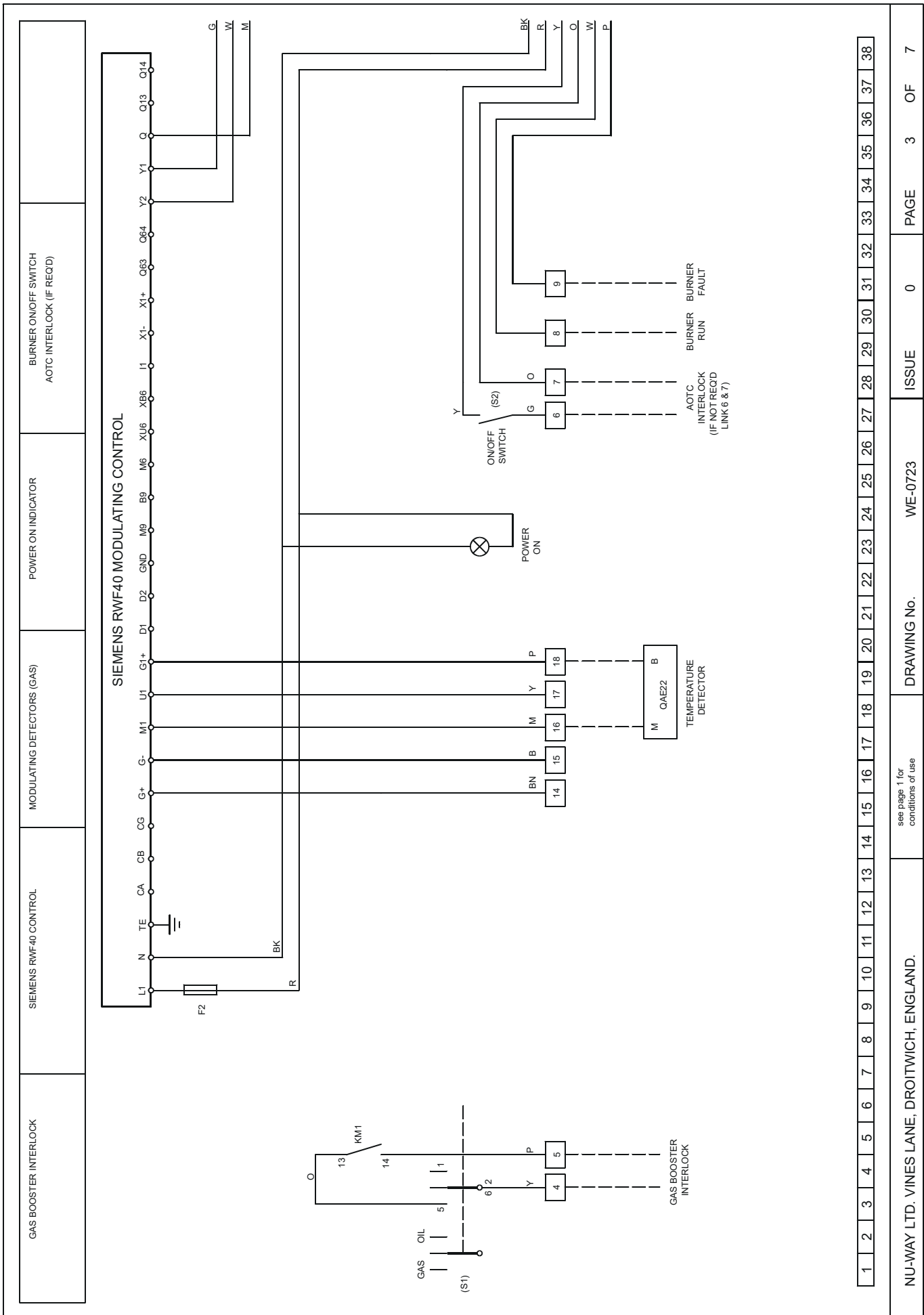

1	2	3	4	5	6	7	8	9	10	11	12	13	14	15	16	17	18	19	20	21	22	23	24	25	26	27	28	29	30	31	32	33	34	35	36	37	38
---	---	---	---	---	---	---	---	---	----	----	----	----	----	----	----	----	----	----	----	----	----	----	----	----	----	----	----	----	----	----	----	----	----	----	----	----	----

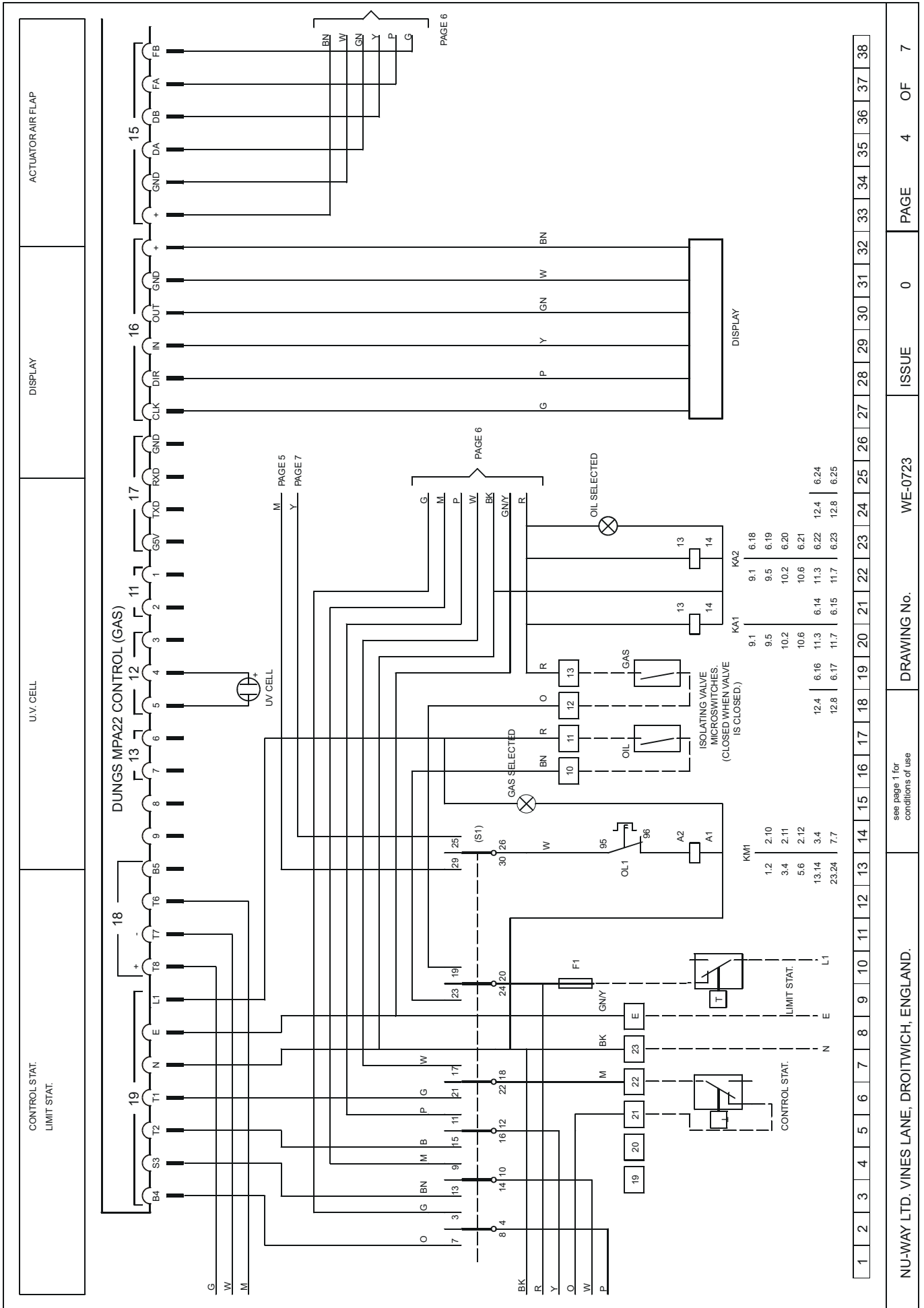

see page 1 for conditions of use

NU-WAY LTD. VINES LANE, DROITWICH, ENGLAND.

DRAWING No. WE-0723

ISSUE 0

PAGE 4 OF 7

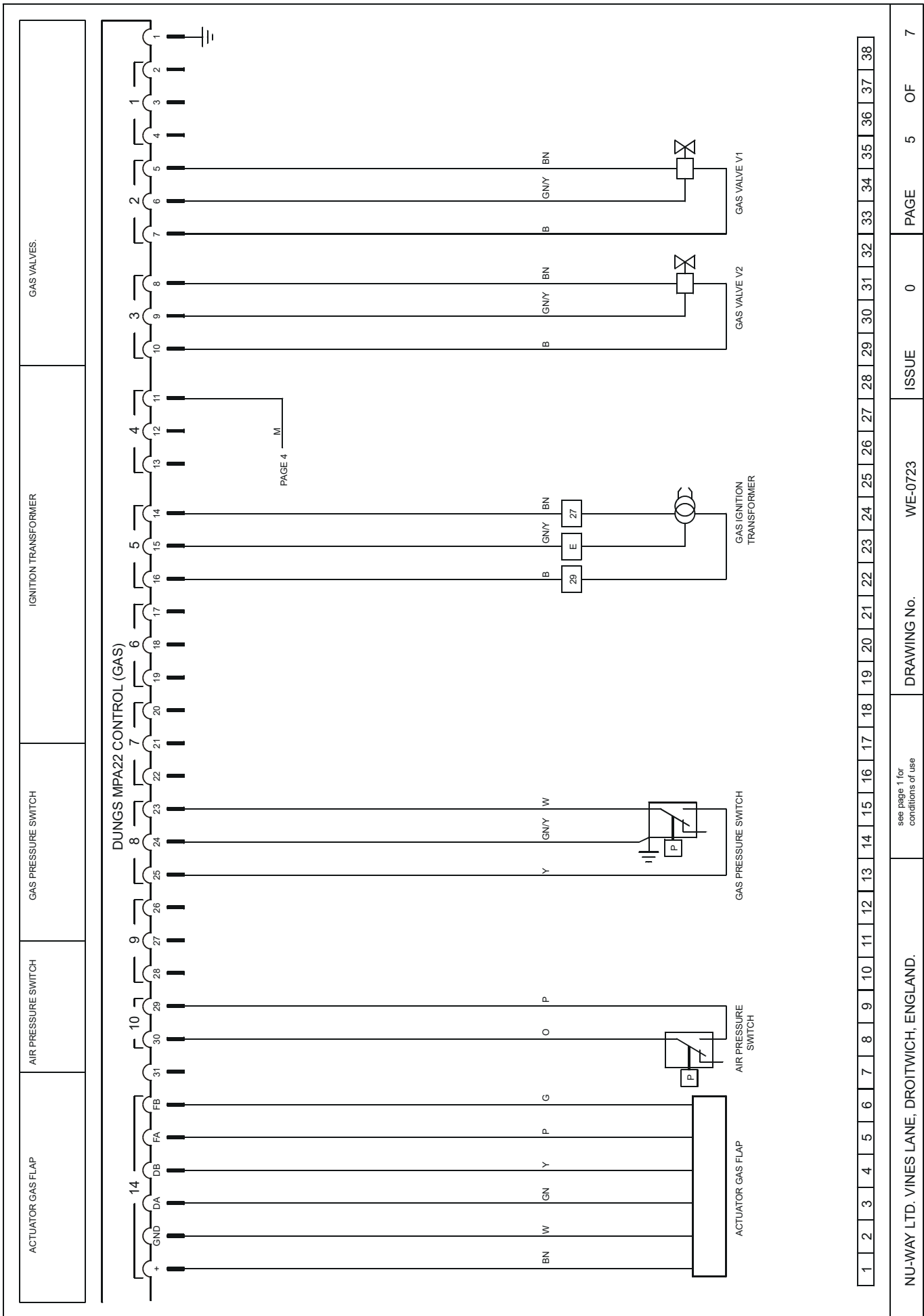

1	2	3	4	5	6	7	8	9	10	11	12	13	14	15	16	17	18	19	20	21	22	23	24	25	26	27	28	29	30	31	32	33	34	35	36	37	38
---	---	---	---	---	---	---	---	---	----	----	----	----	----	----	----	----	----	----	----	----	----	----	----	----	----	----	----	----	----	----	----	----	----	----	----	----	----

NU-WAY LTD. VINES LANE, DROITWICH, ENGLAND.

see page 1 for conditions of use

DRAWING No. WE-0723

ISSUE 0

PAGE 5

OF 7

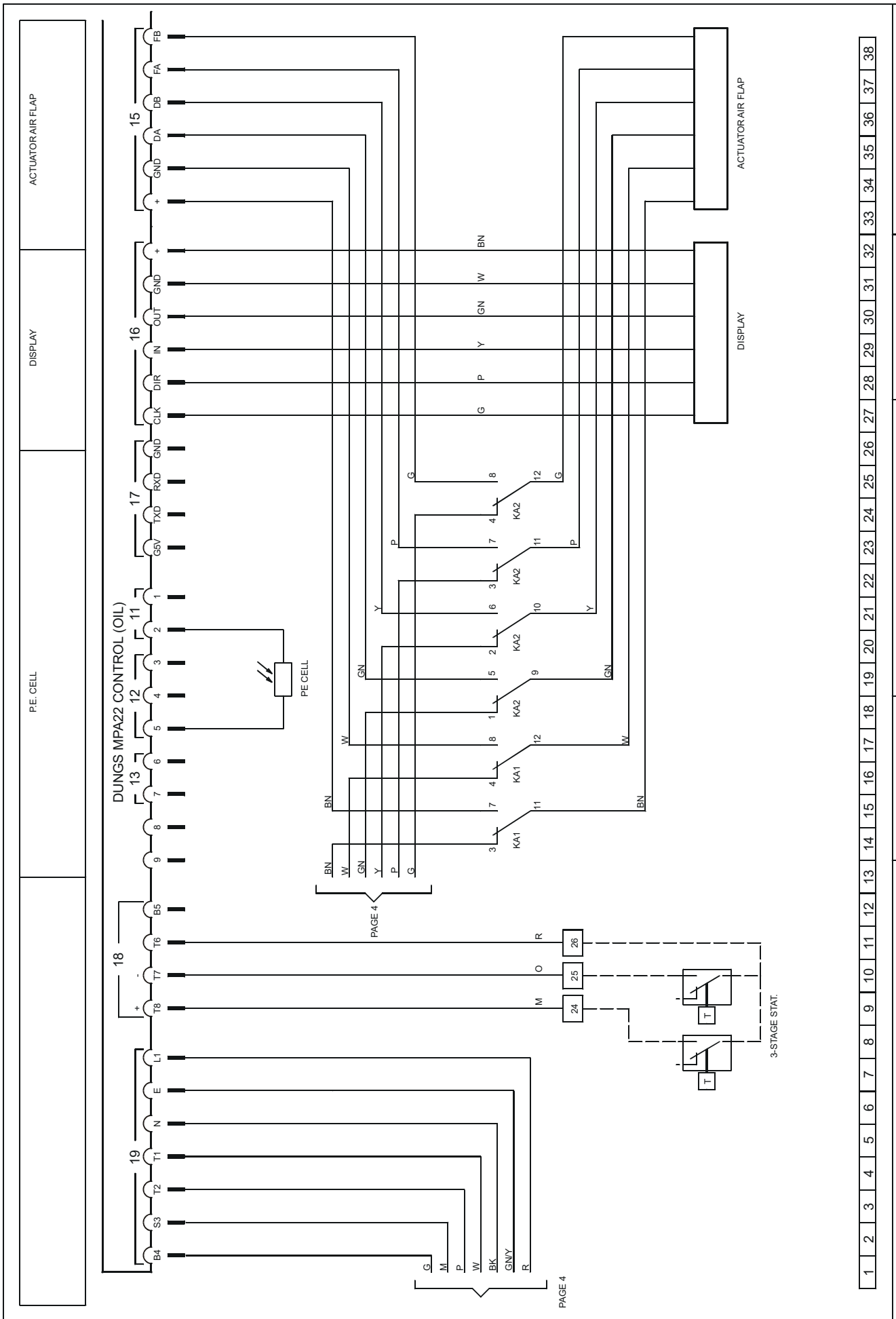

see page 1 for conditions of use

NU-WAY LTD. VINES LANE, DROITWICH, ENGLAND.

DRAWING No. WE-0723

ISSUE 0

PAGE 6

OF 7

1	2	3	4	5	6	7	8	9	10	11	12	13	14	15	16	17	18	19	20	21	22	23	24	25	26	27	28	29	30	31	32	33	34	35	36	37	38
---	---	---	---	---	---	---	---	---	----	----	----	----	----	----	----	----	----	----	----	----	----	----	----	----	----	----	----	----	----	----	----	----	----	----	----	----	----

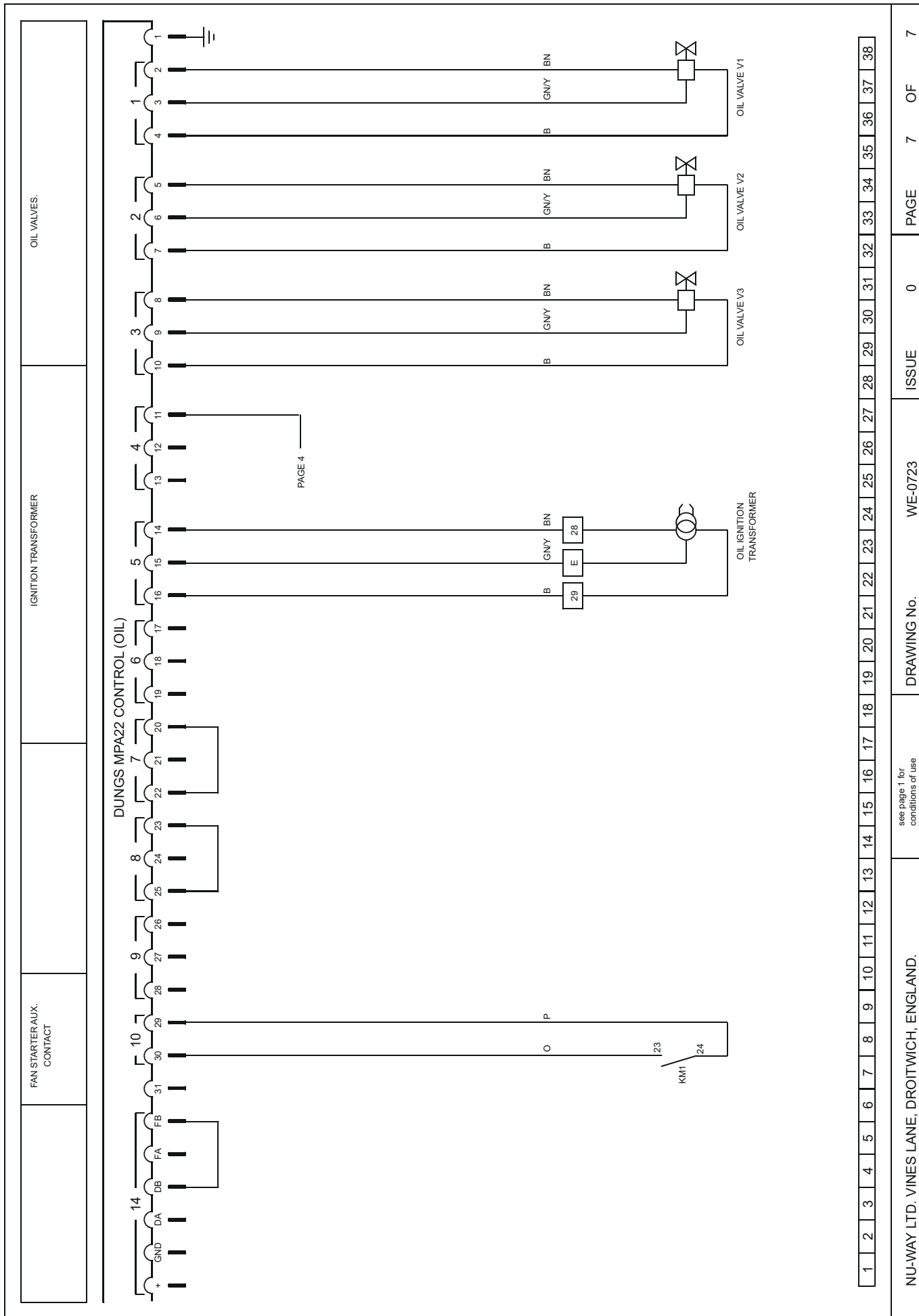

1	2	3	4	5	6	7	8	9	10	11	12	13	14	15	16	17	18	19	20	21	22	23	24	25	26	27	28	29	30	31	32	33	34	35	36	37	38
---	---	---	---	---	---	---	---	---	----	----	----	----	----	----	----	----	----	----	----	----	----	----	----	----	----	----	----	----	----	----	----	----	----	----	----	----	----

NU-WAY LTD. VINES LANE, DROITWICH, ENGLAND.

see page 1 for conditions of use

DRAWING No. WE-0723

ISSUE 0

PAGE 7

OF 7

7

FEATURES

Developed from Worldwide field experience, the NDFL100 38 sets new standards in efficient and reliable operation. The burner is designed to meet the requirements of all international markets.

Delivered ready to install with prewired packaged control system and plug in gas train.

Air Regulation

Air for combustion can be adjusted to give maximum efficiency. A closed position air control is incorporated as standard.

Controls & Operation

Flame supervision is by U.V. cell (Gas) and photocell (Oil). Microprocessor controllers are employed for automatic start up, running, and shutdown of the burner.

Fuel

Natural gas and light distillate oil Class D (1.5 5.5 cSt @ 40°C).

GENERAL

This manual is structured to enable the user to proceed from the delivery of the burner to its commissioning and use.

The conditions to be fulfilled and the controls and adjustments to be used are dealt with in the sequence that should be followed for the correct installation and use. Pre commissioning and Live Run are described, and the location of necessary controls and adjustments to undertake these are illustrated and supported by appropriate tabular matter and graphs.

Routine Maintenance, Fault Finding, and Spare Parts identification complete the manual. literature on proprietary components is available on request.

SERVICES & SITE CONDITIONS

Gas Supply

The gas supply pipework must be constructed and installed in compliance with the appropriate Codes and Standards, and comply with all local conditions. It shall be of sufficient size to satisfy the pressure and volume flow requirements of the burner under all firing conditions.

A 90° manual isolation valve must be fitted upstream of the gas control train to allow the burner to be isolated for maintenance.

To avoid any restriction in gas flow the size of this valve should not be less than that of the gas train.

Fuel Oil Storage and Handling

The requirements of BS2869 will ensure that the fuel is suitable. Under sustained cold and exposed conditions, class D grade of fuel should be stored and supplied to the burner at a minimum temperature of 5°C (14°F).

Fuel Oil Supply

The oil line should consist of copper tube (NEVER galvanised steel). The final connection to the pump inlet port is made with a flexible pipes supplied with the burner. Joints should be made with compression fittings.

When gravity feed is used, the maximum head should not exceed 4m, (35 kPa). The return side of the burner pump **MUST** be piped into the oil supply line at a distance of no less than 1 Metre from the pump inlet connection This will prevent the oil attaining temperature from the oil pump whilst the burner is firing on gas.

On installations where the fuel tank is situated below the level of the burner the maximum suction permitted is 40 kPa (300 mm HG) and a two pipe (supply and return) fuel supply system **MUST** be used.

Gravity feed system

On a single pipe (gravity feed) system, the pump should be primed under gravity from the tank and not by running the pump mechanically. To prime the pump remove the purge plug, connect the purge port to a suitable container.

Suction lift System

The suction line will require priming before energising the pump mechanically. It is essential to ensure that the return pipe is not obstructed in any way. Any obstructions will damage the pump. The fuel supply line may need priming if the oil storage is allowed to drain completely.

Flue and Chimney Requirements

The flue and chimney must be constructed and installed to the appropriate local conditions, Codes and Standards. It shall be of sufficient size to satisfy the volume of flue gases at all firing conditions.

Plant Room Ventilation

An adequate dust free supply of fresh air is required for the burner at both high and low level in accordance with the appropriate standards.

Existing Appliances

In preparing the appliance to receive the burner, a careful inspection should be made of its condition after it has been cleaned thoroughly to remove all adhering tars, scale and dirt.

Combustion Chamber Conditions

When the burner is fitted to an appliance designed to work under balanced or negative combustion chamber conditions, the over fire draught must not exceed 0.25 mbar.

Should the over fire draught exceed this figure, then steps should be taken to reduce it to this level.

ASSEMBLY

Fit the gas train to the gas inlet mounting flange using the gasket nuts and washers provided.

Ensure that the gasket is seated correctly when tightening the assembly.

Connect the four number coded plugs from the gas valves V1 and V2, the gas pressure switch and the gas butterfly valve to the **GAS** MPA22 controller sockets 2,3,7 & 14 respectively.

Do not force the plugs into the sockets. If difficulty is encountered, check the coding to ensure correct location.

INSTALLATION

General

Check that the burner is appropriate for the appliance rating. Detailed burner performance data is given on page XX.

Fitting to the Appliance

If the burner is to be fitted to a new packaged unit, refer to the manufacturers recommendations.

If the burner is to be fitted to an existing appliance, prepare the mounting flange as detailed on page 5.

Ensure the joint between appliance and burner is effectively sealed with the gasket provided.

Unless otherwise specified, the flame tube should be flush with the inner face of the appliance combustion chamber.

Electrical Power Supply

Connect a three phase 50Hz electrical supply to the burner observing all applicable IEE Regulations. Connect all of the applicable external auxiliary controls.

Refer to the electrical supply specifications and connection diagrams shown on pages 8 to 14.

If supplied as a packaged appliance/burner unit refer to the manufacturers instructions.

BURNER AIR CONTROLS

A motorised air flap controls the air for combustion. It is located inside the air inlet, see page 5.

Air Diffuser

The air diffuser creates a pressure drop to ensure good fuel/air mixing and flame stability.

Air Pressure Switch

The air pressure switch is required to prove adequate air flow throughout the burner operating cycle. Air flow failure at any stage after pre purge will result in a lockout, failure during pre purge will result in four restarts before a lockout.

BURNER GAS CONTROLS

Gas Nozzle

The hole in the gas nozzles is designed to suit the output of the particular burner model and gas type being used.

Gas Pressure Switch

The low gas pressure switch is located between the two gas valves and has two functions:

- To monitor the gas pressure during the burner operating cycle. A low gas pressure will result in the safe shutdown of the burner.
- The check the gas leak integrity of the valves.

INTEGRATED VALVE PROVING SYSTEM

The burner comes complete with an integrated Valve Proving System.

A leakage test is performed after every controlled shutdown.

A leakage test is performed before the burner is started after a power failure or fault reset.

Functional sequence

After a controlled shut down, the second main valve is closed after a 2 second delay. The pressure in the test section is thus evacuated and the gas pressure switch opens. A test of the first main valve (V1) commences and during the first pre set test period. The gas pressure switch must remain in the open position, otherwise the burner will lockout and a fault code for 'valve 1 leaking' will be displayed

At the completion of the first test period the first gas valve is momentarily opened and the test section is pressurised with gas, the gas pressure switch closes. A test of the second main valve (V2) commences during the second pre set test period. The gas pressure switch must remain closed, otherwise the burner will lockout and a fault code for 'valve 2 leaking' will be displayed.

At the end of the second test period the valve proving is complete.

BURNER OIL CONTROLS

Oil Nozzle

The oil nozzles are fitted to the front end of the inner assembly and located in the flame tube.

The nozzles should be sized to match the rating and turndown requirements of the appliance.

Oil Control Train

The oil control train consists of a high pressure fuel pump driven by the burner fan motor.

Each oil nozzle is controlled by an individual solenoid valve. A further solenoid valve acts as a safety shut off for all nozzles.

MPA 22 CONTROL UNITS

Engineers who are not experienced with this unit should read all the notes and procedures before attempting to commission the burner.

A separate MPA22 controller and display unit is provided for each fuel. The display unit, as shown on page 18 is used to program the MPA, and to retrieve information from it.

The system has many functions; several of them need a pass code before the user can obtain access to them. Entering this code is described in the following text.

When using the keys on the display unit, the best results are achieved by using a slow deliberate pressure of about 1/2 to 1 second in duration.

Entering the pass code.

Press key numbers (1&2) together for a full commissioning or keys (+&) together for a part commissioning.

The display will show seven short lines, the first flashing and is ready to accept the code.

The default pass-code is 8904236.

To enter the first number (eight) press the plus (+) key eight times, or the minus (-) key twice (10 8=2).

Each press of either key, plus or minus (+/ -) will result in flashing line dropping down indicating that the press has been recorded.

Press key (2) to move to the next number, the second line will start to flash. To enter this number, (nine) in this illustration, press (+) key nine times, or the (-) key once (10 9)=1. Again the flashing line will drop to indicate it has been recorded.

Press key (2) to move to the next number, zero, the third line will start to flash. Zero requires no action therefore move to the next number, (four). Continue this procedure until all the numbers have been entered.

When the last number has been recorded, press the acknowledgement key. The procedure is complete.

If required, pressing key number (1) will return the flashing line to the previous position.

NDFL - GAS

OPERATION

When the burner is switched on the start procedure begins:

The M.P.A. completes a series of internal tests.

Both the air and gas motors check their reference positions.

The air damper moves to the high fire position.

Air pressure switch is checked to ensure that it is in the open position.

The flame monitor checks if flame is present.

If the above is successful, the fan begins the pre purge.

During the pre purge and thereafter the air pressure switch monitors the air pressure.

MULTI-FUNCTIONAL DISPLAY

The MPA22 is controlled by means of 5 keys on the touch sensitive display. The individual parameters are displayed on the liquid crystal display.

The individual display elements and control buttons are explained below.

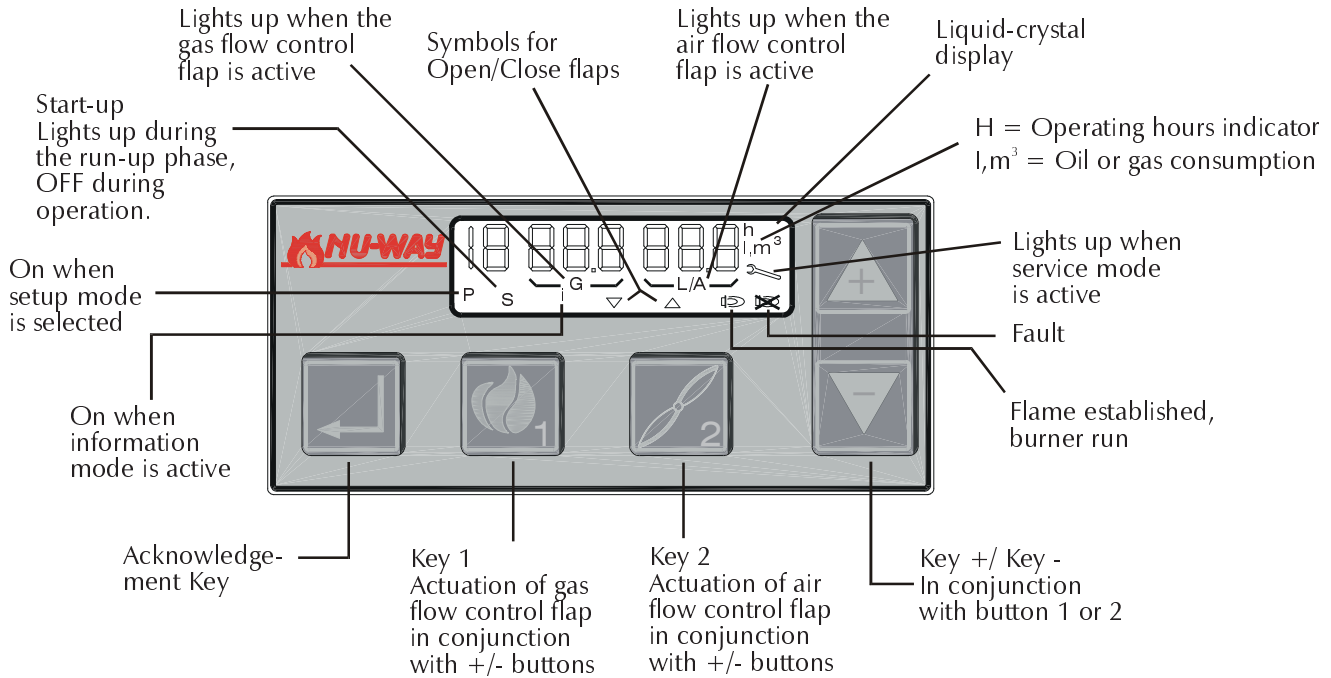

The gas stepper motor opens fully, above 90° and then closes to the ignition position.

After the pre purge period, the air damper moves to the ignition position.

At the start of the ignition and thereafter the gas pressure switch checks the gas pressure.

Ignition takes place and the burner starts to fire.

COMMISSIONING THE BURNER

Re check that the electrical wiring is complete and complies with all Codes and Standards. Check fuses are fitted and correctly sized.

Re check that the gas pipework is correctly installed and there are no leaks.

Set the low gas pressure switch to just above the minimum and the air pressure switch to minimum.

Check that the appliance is in a proper and safe state to be fired.

Set the appliance controls to call for heat.

Set the Fuel Selector switch to Gas (refer to control panel identification on page 7).

Check for Valve Closure

All gas train assemblies are fully leak tested before despatch. A test of the individual gas valves is difficult without specialised testing equipment. However, the following check can be performed to test the security of the valve system.

Fit a manometer to the test point at the inlet to the upstream main safety valve. Open the main upstream manual valve for a few seconds, then close and secure the gas supply.

The manometer will detect any gas leakage and will prove that gas is not leaking past the gas train.

If no drop in pressure is recorded then commissioning can continue until a full valve proving test is completed by the integrated proving system.

Gas Supply Pressures

Refer to the gas supply pressure graphs on pages 20 to 24 of this handbook. The supply pressure must not exceed 100mbar. All pressures shown are measured when the burner is at full firing rate.

Fit a manometer or other approved pressure measuring instrument at the test point on the upstream main safety valve. Open the main isolating manual gas valve. Check there is adequate gas pressure to enable commissioning to proceed.

ESTABLISHING MAIN FLAME

General Notes

In the following sections, reference is made to checking gas flow rates at the gas meter. This is the most accurate method of determining throughputs and should always be used whenever possible. Information regarding the burner head gas pressures is shown on pages 20 to 25. These are intended as a guide to initial burner settings, but should not be relied upon to offer proof of actual throughputs.

IMPORTANT After each adjustment, gas flow rate and flue gas analysis should be checked.

ALWAYS use approved test equipment.

NEVER rely on a visual inspection of the flame as a guide to combustion quality.

Commissioning Procedure

The Nu way NDFL burner has been delivered with initial gas and air settings. These have been applied to the burner during the test and inspection phase of its manufacture. Whilst these settings may enable the burner to operate, they are not intended to be final settings. **A full commissioning procedure must be completed.**

The procedure consists of the following:

- Entering the pass code.
- Reviewing the air and gas set points.
- Firing the burner.
- Commissioning the burner.
- Completing the procedure.

Refer to page 17 for a functional description of the Display unit.

Enter the pass code.

Initial settings for air and gas.

Set Point	Combustion Air	Gas	Firing Rate
P9	65°	90°	High Fire
P1	15°	10°	Low Fire
P0	10°	5°	Ignition Position

The MPA control will calculate values for the intermediate points P2 to P8.

Use the (+) key to move the display forwards from P9 through P1 to P0.

Use the () key to move the display backwards from P0.

To alter the value of any gas setting, move to the required display point (P9,P1 or P0) and use the (1) key in conjunction with the (+) or () keys.

To alter the value of any air setting, repeat the above procedure but using the (2) key in conjunction with the (+) or () keys.

The Low Flame point P1 cannot be set at a higher value than the High Flame point P9.

The initial burner set up is now complete.

Table of Available Gas and Air Settings.

Point	Maximum Angle	Minimum Angle
P0	P1+ 25.5°	0 or P1-25.5°
P1	P0+ 25.5° or P2	0 or P0-25.5°
P2	P1+ 25.5° or P3	P1
The same formula applies to points P3 to P8		
P9	P8+ 25.5° or 90°	P8
Bu	P1	Bo
Bo	P9	Bu

Firing the burner

Scroll through to the GAS EL display by pressing (+), close the burner control circuit. The burner will now start.

The display will show a number scrolling down whilst pre purge takes place, eventually the burner will fire at position P0 and will remain at this position until further actions take place.

Switch the burner off and check the fan motor rotation, which should be anti clockwise, viewed from the motor end. If the rotation is incorrect, please refer to 'Fault Finding' to correct it.

Restart a fresh from entering the pass code and allow the burner to fire at position P0.

- Press (+) to move the control point to P1, the Low Fire position.
- Check that the gas pressure is not excessive.
- Visually check for a clean, safe and stable flame, adjusting the air damper to suit if necessary.
- Press (+) to move the control point to P2, again making any adjustments to keep the flame safe and stable.
- Follow the above procedure through P3, P4 etc. until position P9, the high fire position, is obtained.
- With the gas butterfly set at 90°, adjust the governor on the SKP20 valve to give the required high flame gas flow.
- Adjust the air damper position to give the required combustion analysis. **Note the air damper position.**
- Switch off the burner and restart the procedure from entering the pass code.
- Adjust the value of the air damper at P9 to that noted above.
- Scroll through to the GAS EL display and start the burner.
- At the ignition point P0, adjust the air and start gas values to give a good light up.
Ensure that the start rate gas flow does not exceed 30% of the high flame gas rate. Note the gas and air positions.
- Move to point P1 and adjust the gas butterfly to give the required low flame gas flow. Adjust the air damper to give the required combustion analysis. **Note the gas and air positions.**
- Switch off the burner and re start the procedure from entering the pass code.
- Adjust the value of the gas and air settings to those noted at points P0, P1 and P9.
- Scroll through to the GAS EL display and start the burner.
- Move to point P2, the firing rate will increase.
- Adjust the air damper to give the correct combustion analysis.

- Repeat the above procedure for points P3 through P8, fine tuning the combustion analysis as required.
- When the burner is firing satisfactorily, return the burner to set point P9.

Two further points **Bu** and **Bo**, which correspond to the minimum and maximum firing rates can now be set using the air damper angles that were set at P1 and P9 respectively.

- Press keys (1) and (2) together to access the display point Bu. Wait until the display is steady. Adjust the value to reflect the air damper angle at P1.
- Press keys (1) and (2) again to access the display point bo. Wait until the display is steady. Adjust the value to reflect the air damper angle at P9.
- Finally, press keys (1) and (2) again to enter the information into memory.

The procedure is now complete.

FINAL ADJUSTMENTS

Setting the Air Pressure Switch

Switch off the electrical supply to the burner. Remove the air pressure switch cover. Fit a manometer to the pressure switch to check the accuracy of the dial.

Re establish the electrical supply.

Enter the pass code as described on page 13 for a part commissioning. The default settings will not be displayed. Switch on and the burner will purge then fire at point P0. Slowly turn the adjusting dial clockwise until the flame is extinguished; the burner may go to lockout. Turn the dial one division anticlockwise and let the burner restart, if the burner fails to start, turn the dial another division anticlockwise. Repeat the above procedure at one division per cycle until the burner operates. Adjust the dial a further two divisions anticlockwise.

Switch off the burner, isolate the electrical supply, fit the cover and remove the manometer.

Checking the Flame Signal

The flame signal can be checked by using a micro ammeter. The minimum signal required is 15 μ A.

The MPA display is designed to give an indication of the signal, the screen gives a 0 to 4 readout. See service display screen 18

Setting the Low Gas Pressure Switch

Loss of gas pressure will cause the burner to switch off. After a 2 minute delay the burner will restart. After two restarts the delay is increased to 1 hour. This delay can be removed by electrically isolating the burner and then re establishing the power.

Remove the gas pressure switch cover and allow the burner to establish main flame.

Slowly turn the adjustment dial on the gas pressure switch clockwise until the flame is extinguished and the burner shuts down. Turn the dial slowly anticlockwise one division at a time until the burner restarts and establishes main flame. Turn the dial a further two divisions anticlockwise. Replace the gas pressure switch cover.

FINAL CHECK

Check that all the covers to components have been replaced and that locking devices are properly secured. Check that the appliance control instruments are set to safe limits. On modulation burner check and set the RWF 40.

Commissioning is now complete

Switch on the electrical supply.

The burner will now operate until switched off.

- a) by controlling instruments of the appliance
- b) manually
- c) by power failure. Upon restoration of power, the burner will restart automatically and follow the normal sequence.

THE LANDIS & STAefa MODULATION CONTROLLER, TYPE RWF 40

Basic display

The diagram below shows the RWF40 after switching on the supply voltage. This condition is called the basic display. The actual value and the currently active set point are shown here. Manual operation, self optimization, the operating parameter and configuration levels can be activated from here.

To change the working set point.

The operating display shows the actual pressure/temperature of the boiler in red and the required set point pressure/temperature beneath in smaller green digits.

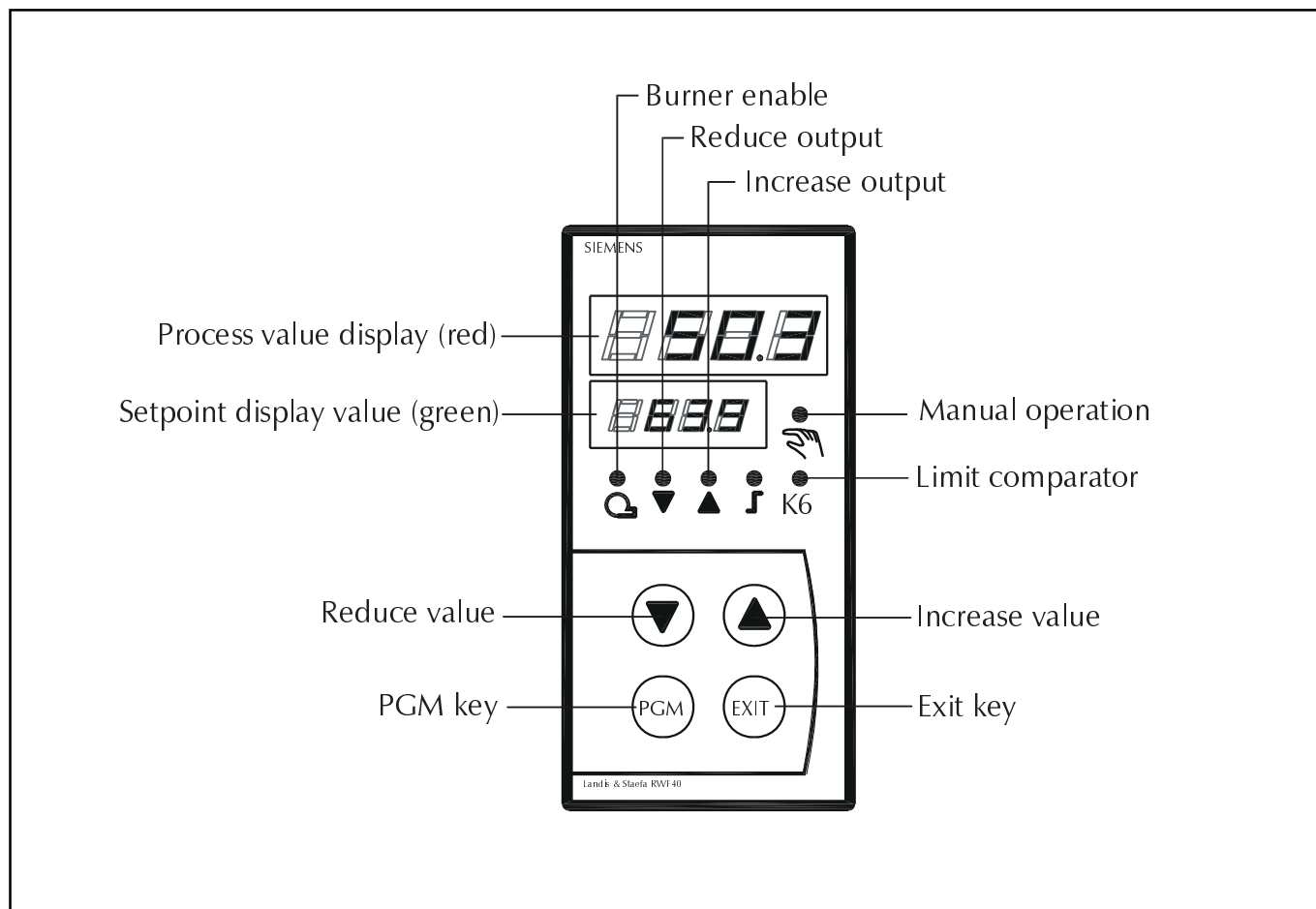

One quick press of the PGM button, the display changes to show the set point as the larger red digits and the SPI in the lower small green digits.

Alter the red display using the up/down buttons to show the new required set point, press exit or let the unit time out to return to the basic display which should be the new set point figure.

To enter a new parameter

The parameters dictate the way in which the burner firing rate alters in response to changes in the pressure/temperature of the boiler.

A major factor that determines the need to change the parameters is if the burner is fitted to a steam or hot water boiler. The table below indicates the parameter and it's setting for steam and hot water boilers. It must be emphasised that it is only an indication and any departure from these settings should be made in small increments, with time given to see how the burner is reacting to the changed parameter.

Press and hold the PGM button down until the green set point figure changes to an AL, the larger upper figures show the value. Use the up/down buttons to set the new value, press the PGM button to enter the value and change to the next screen. To cancel an entry press exit. Scroll through the screens, (PGM button) modifying any value found to be in error (up/down buttons). At the last screen the PGM button will return the controller to the original operating display.

At any point in the procedure the original operating display can be obtained by letting the unit time out, the value in the display at the time out will be accepted.

A value can only be altered within the permitted range of that parameter. All other parametrs must remain as supplied.

Note: The detector range parameters SCL & SCH are given as °C for Hot Water (temperature) and bar for Steam (pressure).

NDFL - Oil

OPERATION

There are three atomising nozzles. The top nozzle only sprays on low flame whilst two spray together for the intermediate flame and all nozzles spray on high flame. The oil operating pressure is 300 psi.

RWF RECOMMENDED SETTINGS			
Parameter	Display	Hot Water	Steam
Proportional band	Pb1	10	1
Derivative time	Dt	10	5
Reset time	Rt	50	20
Actuator time	Tt	Set to the Air Damper running time between low & high flame	
Switch on threshold	Hys 1	0	0
Upper off threshold	Hyst 3	999.9	999.9
Detector: range start	SCL	0	0
Detector: range end	SCH	100	25

At the start of the firing cycle, there is a pre purge with forced air and ignition. At the end of this period, the air damper moves from the high fire position to the ignition position. After a delay, the low flame and safety (if fitted) solenoid valves are energised, allowing oil to flow. The burner will light, and the ignition is switched off. After a stabilising period, the air damper moves to the low fire position. If the flame fails to establish the burner will go to lockout. If there is flame failure during operation, the burner will shut down, and a single restart cycle will follow.

Three-Nozzle System

When the air damper moves to the next pre set positions, the nozzle control valves open in sequence. The burner will be held in any of the three positions under the control of the boiler thermostats.

COMMISSIONING THE BURNER

Check that the electrical wiring is complete and complies with all applicable Codes and Standards. Check that the fuses are fitted and correctly sized.

Check that oil supply pipework is correctly sized and has been checked for leakage.

Check that oil is available at the fuel pump at the correct pressure.

Check or fit nozzles of correct size for appliance.

Check that the electrode setting is correct; see page 6.

Make all personnel involved in the commissioning aware of the location of the emergency oil and electricity isolation points.

Ensure that the oil pump is primed, see page 15.

Establish that the appliance is in a proper and safe state to be fired.

Set the appliance controls to call for heat.

Set the Fuel Selector switch to Oil (refer to control panel identification on page 7).

ESTABLISHING MAIN FLAME

The instructions in this section are presented as a continuous sequence. No separate set of actions should be followed in isolation without paying particular attention to any safety precautions such as isolating the electrical supply to the burner which should precede such actions.

ALWAYS use approved test equipment for combustion quality.

NEVER rely on a visual inspection of the flame.

Commissioning Procedure

The Nu way NDFL burner has been delivered with initial air damper and fuel settings. These have been applied to the burner during the test and inspection phase of its manufacture. Whilst these settings may enable the burner to operate, they are not intended to be final settings.

A full commissioning procedure must be completed.

The procedure consists of the following:

- Entering the pass code.
- Reviewing the default set points.
- Firing the burner.
- Commissioning the burner.
- Completing the procedure.

Refer to page 18 for a functional description of the display unit.

Enter the pass code.

Initial Settings - Air Damper

Set Point	Value	Description
P9	60°	High fire air damper position.
P3	30°	Mid fire air damper position
P1	10°	Low fire air damper position
P0	5°	Ignition air damper position
P2	15°	Mid fire valve - low to mid
P4	35°	High fire valve - mid to high

Use of the (+) key will move the display forwards from P9 through P3, P1, and hence to P4. Likewise, use of the () key will move the display back to the previous display and hence to P9.

To alter the pre set working point, move to the required display, press the (2) key with either the (+) to increase or the () to reduce the angle required.

It should be noted that the point P0 cannot be set above point P1, and P1 cannot be set above P3. This note applies equally, to the other points, either in this review stage or more importantly with the burner firing whilst being tuned.

The display order changes from P9 through P3, P1, P0, P2, to P4 when in the commissioning mode.

The burner starts at the ignition point P0 and will remain in this position until the (+) key is pressed, the air damper moves to the value given in P1.

With the next press of the (+) key the burner firing rate increases to the mid firing position, P3. Continuing to P9, P2 and finally to P4 with each press of the (+) key.

Returning to previous displays can be achieved by use of the () key, similar to the pre setting mode. If during the commissioning procedure the burner is switched off or is locked out, the commissioning will need to start at the beginning by entering the password.

At the end of the procedure, with the burner firing and the display in P4, the new setting can be entered into the memory by pressing the (1) & (2) keys.

The initial burner set up is complete.

Firing the burner.

When all the pre firing checks are complete and the burner is in a safe state to be fired, switch the electrical power on to the burner but ensure that the control circuit is broken.

Enter the passcode by referring to page 17.

Press the (+) key and scroll through the pre set working points, amending any value if needed.

The action requires six presses of the (+) key to gain access to the P4 display. Pressing the (+) key one more time and closing the control circuit starts the burner.

Switch the burner off and check the fan motor rotation, which should be anti clockwise, viewed from the motor end. If the rotation is incorrect, please refer to 'Fault Finding' to correct it.

Restart the procedure from entering the pass code.

The display will show a number scrolling down as pre purge takes place, eventually the burner will fire at position P0, press the (+) to move to P1, the low fire position.

Check that the oil pressure is not excessive.

Visually check for a reasonable clean flame. Increase the air damper angle by pressing the (2) & (+) keys. The maximum angle available without increasing the P2 setting is 14.9°. If the combustion is so poor that it unsafe to proceed, switch the burner off and re start, beginning with the passcode. Increase the values of P1, and P2 while scrolling through the initial settings.

When a reasonable flame is achieved at P1, slowly increase the oil pressure to the required value. Adjust the air damper angle by pressing the (2) & either the (+) or () keys to give acceptable combustion.

Move to the next position, P3 by using the (+) key. The burner firing rate will increase to the mid fire position, the combustion can be set by adjustment of the air damper with the (2) & either the (+) or () keys.

Note: The range of the angular movement is limited by the positions of P2 and P4. If it is necessary to adjust these, scroll to the required display using the (+) key. The burner will operate at the initial high flame position whilst adjusting either. Make the adjustment with the (2) & either the (+) or () keys. Whilst in the high fire position, check and set the firing rate. Return to P9 using the () key, and adjust to give acceptable combustion.

Return to P3 using the () key, and adjust to give acceptable combustion.

Return to the previous P1 and P0 using the () key, and fine tune where necessary.

Scroll up using the (+) key to P2, set this value midway between P1 and P3.

Scroll up using the (+) key to P4, set this value midway between P3 and P9.

Scroll up and down the firing range to confirm that the burner is working and changing firing stages satisfactorily.

Return to P4 and press the (1) & (2) keys simultaneously, the new information is entered into the burner memory and the procedure is complete.

If the procedure is not completed and no action takes place for approximately 30 minutes the burner will switch off.

An adjustment of a working point or a part commissioning can be achieved by entering the passcode pressing the (+) & () keys together. Switch on and the burner will purge, then fire at point P0. Follow the above procedure to scroll up and down the working positions, amend any found unsatisfactory. Continue through to P4 and complete the procedure.

SAFETY CHECKS

Remove the photocell from its holder and cover this whilst the burner is running. The burner should stop firing within 2 seconds. The control re cycles and attempts to re start the burner. As the photocell cannot see light, the control will go to lockout shortly after flame appears.

Expose the cell to strong light. Press the acknowledgement key and allow the control to recycle. As the photocell can see light, the control will go to a fault condition.

Replace photocell in its holder, and press the acknowledgement key.

FINAL CHECK

Check that all the covers to components have been replaced and that locking devices are properly secured. Check that the appliance control instruments are set to safe limits.

Commissioning is now complete

The burner will now operate until switched off.

a) by controlling instruments of the appliance.

- b) manually.
- c) by power failure. Upon restoration of power, the burner will restart automatically and follow the normal sequence.

MPA DISPLAYS

Standby Display

Screen	Information
OFF	After shutdown
OFF U	Due to low voltage
OFF S	Safety circuit open
OFF E	Due to eBUS

Operating Display

TEST	Information
TEST	Internal tests
L	Air stepper motor check
6	Gas stepper motor check
1	Safety and control circuit check
2	Air stepper motor driving to P9
3	Burner fan start
4	Pre-purge period
5	Pre-purge period
6	Pre-purge period, gas stepper motor driving to P0
7	Air stepper motor driving to P0
8	Pre-ignition
9	Safety period
10	Stabilisation time
11	Stepper motors driving to P1
12	Operating position
13	Gas valve test, phase 1
14	Gas valve test, phase 2
15	Gas valve test, phase 3
16	Gas valve test, phase 4
17	Post-ventilation

18	Waiting time
OFF	Standby

Information Display

The information display can be accessed only from the operating display, and can be obtained irrespective of burner status. Press the acknowledgement key and hold for about 1 second, a small i will be highlighted. If the key is continued to be pressed, the display will change to service mode, indicated by a spanner symbol. Should this occur, take no action and the display will revert to the original after about twenty seconds.

Start afresh, but release the key while the small i is highlighted.

When in the information mode, the display will move to the next screen and finally back to the operating display with each press of the acknowledgement key.

Screen	Information - Gas
0	Total cubic meters of fuel consumed
1	Total hours of operation
4	Number of successful starts
5	The software version number
6	The software creation date
7	The serial number of the controller
8	The production date of the controller

Screen	Information - Oil
0	Total litres of fuel consumed
1	Operating hours first stage
2	Operating hours second stage
3	Operating hours third stage
4	Number of successful starts
5	The software version number
6	The software creation date
7	Serial number of the controller
8	Production date of the controller

Service Display

The service display can be accessed only from the operating display, and can be obtained irrespective of burner status. Press the acknowledgement key, and hold for about 2 seconds, a spanner symbol will be highlighted. When in the service mode, the display will move to the next screen and finally back to the operating display with each press of the acknowledgement key.

Screen	Information - Gas
0	Air and gas setting point P0
1	Air and gas setting point P1
2	Air and gas setting point P2
3	Air and gas setting point P3
4	Air and gas setting point P4
5	Air and gas setting point P5
6	Air and gas setting point P6
7	Air and gas setting point P7
8	Air and gas setting point P8
9	Air and gas setting point P9
10	Most recent fault code
11	Second last fault code
12	Third last fault code
13	Fourth last fault code
14	Fifth last fault code
15	Sixth last fault code
16	Testing time Y2
17	Testing time Y3
18	Flame quality indication (1-4)
19	eBus address
21	Integrated valve test, on/off
22	Lower limit of modulation
23	Upper limit of modulation
24	Controller address
25	Motor speed
26	Motor rotation and reference

Screen	Information - Oil
0	Air setting point P0
1	Air setting point P1
2	Changeover point P2
3	Air setting point P3
4	Changeover point P4
9	Air setting point P9
10	Most recent fault code
11	Second last fault code
12	Third last fault code
13	Fourth last fault code
14	Fifth last fault code
15	Sixth last fault code
18	Flame signal indication (1-4)
19	eBus address
20	Status indicator
24	Controller address
25	Motor speed
26	Motor rotation and reference

ROUTINE SAFETY CHECKS

TO BE CARRIED OUT ONLY BY QUALIFIED AND EXPERIENCED PERSONNEL.

Check that the plant room is ventilated at all times. Frequently inspect the air inlet of the burner and ensure that there are no obstructions to air flow.

Flame Detection System (UV Cell)

Switch off the electrical supply to the burner. Remove the UV cell from the burner casing and cover the quartz glass envelope to exclude any light. Do not touch the quartz glass with fingers.

Switch on the power supply. Check that the burner locks out at the end of the ignition cycle. Switch off the power supply. Replace UV cell. Switch on the power supply. Reset lockout.

Flame Detection System (Photocell)

Carry out the photocell check sequence outlined in the section Safety Checks on page 24.

ROUTINE MAINTENANCE

Switch off electrical supply and gas/oil supplies to the burner.

Combustion Air Fan

Clean the blades regularly with a stiff brush. Access is obtained through the burner top cover. Care should be taken to avoid damaging the fan blades. Check that the air inlet into the fan is clean.

Inner Assembly

Remove the 2 locking nuts and washers securing the hinged extension.

Open the hinged extension and disconnect the ignition electrode H.T. leads.

Disconnect the manifold oil feed at the flexible connection.

Remove the 3 Din plugs from the triple oil valve assembly **having first made note of their positions.**

Loosen the 2 nuts securing the oil inner assembly manifold to the hinge flange and slide the oil inner assembly backwards until it clears the burner.

Remove the cap head screw securing the gas inner assembly to its manifold. Carefully withdraw the inner assembly from the hinged extension.

Air Diffuser and Gas Nozzle

Clean using a stiff brush.

Ignition Electrodes

Clean and check the electrodes are not cracked or worn. Renew if necessary.

Check the settings of the ignition electrode and reset if necessary, details are shown on page 6.

Oil Nozzles

The oil nozzles should be replaced after approximately 2000 hours operation.

Filters

A filter is fitted within the pump. To gain access, remove pump and endplate. Withdraw filter and clean it in paraffin, or similar solvent. Replace filter and pump endplate.

A filter should be fitted in the fuel supply pipe. If fitted with a disposable element this should be replaced at least once per year. If the filter has a re useable element this should be cleaned at suitable intervals.

It will be necessary to remove air from the system after the above operations by bleeding the pump.

Fan Motor

The motor requires no maintenance. It has bearings that are factory lubricated for the life of the motor.

Replacement of Control Valve SKP20

Should the SKP20 valve require replacing due to mechanical or electrical failure, then the governed gas pressure will have to be reset. It is essential that only qualified combustion engineers undertake replacement of these components.

FAULT FINDING

Any modifications to the installation or component settings resulting from actions suggested below may require the re establishment of the various settings.

During the purges and firing cycles the MPA control checks for both internal and external faults. Should a fault be found the control causes a safety shutdown and flashes an error code on the display. The last six error codes are kept and can be obtained from the service mode screen ten onwards.

MPA Error Codes

Code	Error Description
20H	Air pressure switch not in rest position
21H	Air pressure switch failure
22H	Gas pressure switch failure
25H	No flame after safety period
26H	Extraneous light
27H	Flame failure during operation
2BH	Short circuit in UV/Photocell
43H	First valve leaking
44H	Second valve leaking
66H	Gas servomotor or coding plug
68H	Air servomotor acknowledgement
69H	Gas servomotor acknowledgement
6AH	Air motor position out of tolerance

Code	Error Description
6BH	Gas motor position out of tolerance
6EH	Motors have been interchanged or incorrectly connected
6FH	Burner recognition or zero reference
All others	Internal device fault

- That nozzle is not blocked and that atomisation is correct
- That all filters are able to pass oil
- That the oil solenoid valve opens
- That fuel pressure delivered by the pump is correct

Burner Fails to Establish Main Flame - Gas firing only

Check:

- The gas butterfly is operating correctly
- The combustion air is set correctly
- There is sufficient gas

Incorrect Rotation of Burner Motor

The Fan Motor rotates clockwise viewed from the shaft end. If the rotation is incorrect, interchange any two phases.

Burner Motor Fails to Start

Check:

- that the electrical supply is available and the burner is correctly wired
- all fuses for continuity and size
- all control instruments are "calling for heat"
- the MPA control is not locked out

Gas firing only:

- The gas supply is not isolated
- There is sufficient gas pressure
- The gas pressure switch is correctly set

Motor starts but burner will not light

If the flame is not established the burner will lock out.

Check :

- The air setting is correct.
- All connections including high voltage leads, with mains switched off.
- That there is an arc at the electrodes.
- The electrode gap and correct if necessary, see page 6.
- That the electrodes are not short circuited and that the insulators are not cracked or soiled.

Gas firing only:

- There is sufficient gas under ignition conditions
- The gas valve(s) operate correctly

Oil firing only:

- Whether the nozzle is spraying oil. If not check that there is an oil supply to the burner and that all isolating valves are open

Unstable pump pressure - Oil firing only

- On suction lift systems, check that the pump has been correctly primed by disconnecting return pipe from pump. Air free fuel should flow out when the pump is run.
- Check that all pipework and connections on the suction side are free of leaks and that there are no blockages.
- Check internal by pass plug is fitted to pump, Check that there is a suitable spring loaded non return valve is fitted.
- On gravity feed systems, remove the purge plug to ascertain that air free oil flows out (do not run motor).

Burner fires then locks out - Oil firing only

Check:

- That photocell is clean and correctly located.
- That the air damper and burner head setting are correct and re adjust as necessary.

Burner fails change to high flame - Oil firing only

Check:

- The settings and operation of the controlling instruments. Check that the high/low magnetic valve is opening.
- That there is high flame signal from control box.

Flame failure in changing to high flame - Oil firing Only

(or small 'sparky' high flame).

- High flame nozzle blocked / excess air condition.

Burner fails change to low flame - Oil firing only

(except on initial start).

- Check setting and operation of high/low control instrument.

Burner locks out without attempting to light

If the UV/photocell detects light before the pre purge period, the burner will lockout, the cause will be extraneous light.

SPARE PARTS

For spare parts contact Nu way's Parts and Components Division at the address and telephone number listed on the rear cover of this handbook.

To avoid delays, please provide the burner model and specification number.

COMMISSIONING SHEET - NATURAL GAS

The details below are to be completed by the Commissioning Engineer

Installers Name:

Address:

Site Address:

Appliance:

Type:

Size:

Serial No. :

Burner:

Type: NDFL

Size: 100-38

Serial No. :

Commissioning Date:

Spec'n No. : X29-658S

Guarantee Expiry Date:

Gas Type: Natural Gas

Gas Pressure upstream of the main gas governor:

Standing (mbar):

Running (mbar):

Set point	P0	P1	P2	P3	P4	P5	P6	P7	P8	P9
Gas pressure at burner head (mbar)										
Gas rate (m ³)										
Heat input (MJ/hr)										
CO (%)										
CO ₂ (%)										
Gas butterfly setting (X°)										
Air damper setting (X°)										
Gross flue gas temp. (°C)										
Ambient temp. (°C)										
Nett flue gas temp. (°C)										
Efficiency (%)										

COMMISSIONING SHEET - CLASS D OIL

The details below are to be completed by the Commissioning Engineer

Installers Name:			
Address:			
Site Address:			
Appliance:	Type:	Size:	Serial No. :
Burner:	Type: NDFL	Size: 100-38	Serial No. :
Commissioning Date:			Spec'n No. : X29-658S
Guarantee Expiry Date:			Fuel Oil Type: Class D
Oil Pressure upstream of burner pump			
Nozzle Type/Rating	Spray Angle		

Set point	P0	P1	P2	P3	P4	P9
Oil Throughput (kg/hr)						
Heat input (MJ/hr)						
O ₂ (%)						
CO (ppm)						
CO ₂ (%)						
Smoke Number						
Air damper setting (X°)						
Gross flue gas temp. (°C)						
Ambient temp. (°C)						
Nett flue gas temp. (°C)						
Efficiency (%)						

BURNER SERVICE RECORD

The details below are to be completed by the Servicing Engineer

This sheet to be completed and signed following each service / adjustment

Date	Details Of Service	Signature

The details below are to be completed by the Servicing Engineer

This sheet to be completed and signed following each service / adjustment

Date	Details Of Service	Signature



BS EN ISO 9001
CERT No. FM00921



NU WAY LIMITED, P.O.Box 1, Vines Lane
Droitwich, Worc, WR9 8NA, England
Telephone: (01905) 794331
e mail: info@nu way.co.uk
Fax: Office (01905) 794017
Parts & Components (01905) 795829