

Safe









Lindab	1
General information and theory	2
Safe	3
Silencers	4
Dampers & Measure units	5
Fire dampers & Smoke evacuation	6
Air valves	7
Roof hoods	8
Other circular products	9
Transfer	10
Rectangular	11
Flexible ducting	12
Isol	13
Access doors	14
Smart tools	15
Duct suspensions & Support systems	16
Fastening material	17
Index	18

Content – Safe

Circular duct

	SR..... 56
	SRL..... 59

Bends

	BU 90°..... 62
	BU 60°..... 63
	BU 45°..... 64
	BU 30°..... 65
	BU 15°..... 66
	BFU 90°..... 67
	BFU 60°..... 68
	BFU 45°..... 69
	BFU 30°..... 70
	BFU 15°..... 71
	BKU90°..... 72
	BKFU 90°..... 73
	BKMU 90°..... 78
	BKFMU 90°..... 79
	BSU 90°..... 74
	BSU 45°..... 75
	BSFU 90°..... 76
	BSFU 45°..... 77
	BKCU 90°..... 80
	BFKCU 90°..... 81
	BBKCU 90°..... 82
	BFBKCU 90°..... 83
	BU GJUT..... 84
	BSIU GJUT..... 85

Reducers

	RCU..... 86
	RCFU..... 88
	RU..... 91
	RFU..... 93
	RFLU..... 95
	RCLU..... 98
	RCFLU..... 102
	RLU..... 105

Saddle

	PSU..... 108
	PSVU45°..... 111

T-pieces

	TCPU..... 115
	TCSIU GJUT..... 120
	TCPU GJUT..... 121
	TCPU GIPS..... 122
	TCPU KORT..... 123
	TCU..... 124
	TU..... 128
	TCPMU..... 133
	TVU45°..... 134

X-pieces

	XCPU..... 137
	XCU..... 140
	XU..... 142
	XVU45°..... 146

Y-pieces

	YVU45°..... 149
---	-----------------

T-pieces

	TSTCU..... 151
	TSTU..... 155

Take-offs

	ILRU..... 160
	ILU..... 161
	ILF..... 162
	ILRNU..... 163
	ESNU..... 164
	EPNF..... 165
	ILKNU 50..... 166
	ILKNU 100..... 167
	ILKNF 50..... 168
	ILKNF 100..... 169
	ILVU45°..... 170
	AVU..... 171

Couplings

	NPU..... 172
	NPEU..... 173
	SNPU..... 175

Female couplings

	MF..... 174
	SMFU..... 177

End caps

	EPF..... 179
	ESU..... 180

Access doors

	See chapter Access doors
	EPFH..... 647
	ESHU..... 648
	KCU..... 652
	KCIVU..... 653
	KCRU..... 649
	TLU..... 650

Bends

Overview bends – ordinary

Ød ₁	Short radius $r_m \approx 0,6 \cdot d_1$		Normal radius $r_m \approx 1 \cdot d_1$		Long radius $r_m \approx 1,5 \cdot d_1$	
	Pressed and seam welded	Segmented and lockseamed	Pressed and seam welded	Segmented and lockseamed	Pressed and seam welded	Segmented and lockseamed
63	BKU 90°		BU 90° BU 60° BU 45° BU 30° BU 15°		BSU 90° BSU 45°	
80						
100						
125		BKFU 90°		BFU 90° BFU 60° BFU 45° BFU 30° BFU 15°		BSFU 90° BSFU 45°
160						
200						
250						
315						
400						
500						
630						
800						
1000						
1250						



Overview bends – others

Ød ₁	Short radius $r_m \approx 0,6 \cdot d_1$	Normal radius $r_m \approx 1 \cdot d_1$						
	Pressed and seam welded	Segmented and lockseamed	Pressed and seam welded	Segmented and lockseamed	Segmented and lockseamed	Segmented and lockseamed	Pressed and seam welded	Pressed and seam welded
63	BKMU 90°		BKCU 90°		BBKCU 90°		BU GJUT	BSIU GJUT
80								
100								
125		BKFMU 90°		BFKCU 90°		BFBKCU 90°		
160								
200								
250								
315								
400								
500								
630								

Female end		Cleaning stud at side		Cleaning stud at back		Female end and nail flange	Air valve socket and nail flange
------------	--	-----------------------	--	-----------------------	--	----------------------------	----------------------------------



T-pieces and saddles

Overview T-pieces – ordinary

Ød ₁	Short installation length	Normal installation length	
	Pressed and seam welded	Pressed and seam welded	Segmented and lockseamed
63	TCPU KORT	TCPU	TCU TU
80			
100			
125			
160	TCPU	TCU TU	TCU TU
200			
250			
315			
400	TCPU	TCU TU	TCU TU
500			
630			
800			
1000	TCPU	TCU TU	TCU TU
1250			



Overview saddles and T-piece

Normal installation length	
Pressed and seam welded	Segmented and lockseamed
PSU	TSTCU TSTU



Overview T-pieces – others

Ød ₁	Short installation length	Normal installation length					
	Pressed and seam welded	Pressed and seam welded	Pressed and seam welded	Pressed and seam welded			
63	TCPU GIPS	TCPMU	TCPU GJUT	TCSIU GJUT			
80							
100							
125							
160	TCPU GIPS	TCPMU	TCPU GJUT	TCSIU GJUT			
200							
250							
315							
400	TCPU GIPS	TCPMU	TCPU GJUT	TCSIU GJUT			
Female end					Female end	Female end and nail flange	Air valve socket and nail flange



The Safe system

The Safe-system

- Safe is a quickly assembled system for round ventilation ducts.
- Safe is type approved to class D by SITAC, no. 1358/88.
- The complete programme has dimensions according to Eurovent 2/3 and Swedish Standard SS-EN 1506.
- The system is based on a double-lipped, factory-installed seal made from EPDM rubber. The moulding, which can withstand rough handling, and is almost insensitive to temperature changes, gives a very airtight seal.

Advantages of the Safe-system

- Quick assembly.
- Factory fitted seal with no loose fittings.
- Can be twisted and adjusted with tightness unaffected.
- Installation without sealant or solvents.
- Can be used in all climates.
- Seal moulding remains tight from 5 000 Pa negative pressure to 3 000 Pa positive pressure. Duct resistance to collapse differs from these pressures, and is noted on page 49.
- Type approved to sealing class D.

Click function

The Click function exists in principle on all Safe-products. The exceptions are stated under each product.

The Click function exists on the dimensions Ø 80–315.

The Click function means;

- a. that an end with male measure has an open turned-over end and
- b. that an end with female measure has a number of notches.

Type approval

Approval no 1358/88 means that the Safe-system complies with the requirements for tightness class D without any demand for pressure testing after installation.

The approval is only valid on condition that all fittings are marked by us in accordance with the example and are installed in accordance with the accompanying installation instruction.

Marking

Each individual product is marked with a special label or stamped in the metal.



Tightness

A duct system will never be “completely tight”. The system will normally have some leaks at joints between ducts and fittings. The leakage will also increase as the pressure difference between the in- and outside of the duct sides increases.

The leakage factor in (l/s)/m² is always specified in relation to the pressure difference in Pa. (The unit (l/s)/m² denotes the leakage flow in l/s in or out of the system in relation to its duct area in m².) The graph below shows the leakage factor for the sealing classes A–D as a function of the pressure difference.

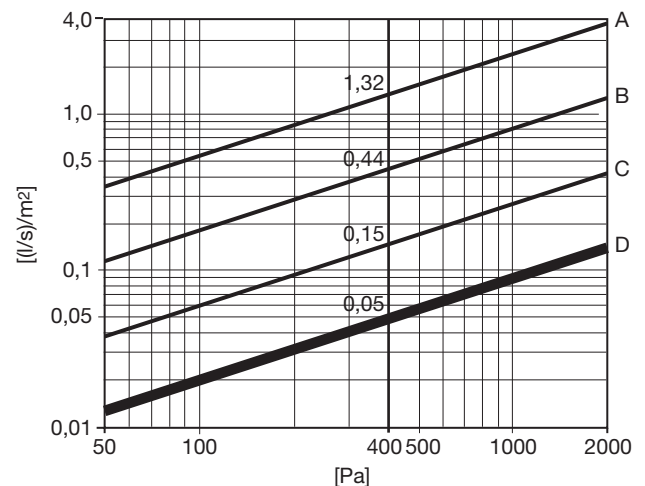

The graph shows that sealing class D is 3 times better than class C, which in turn is 3 times better than class B etc. Class D thus entails demands on not only the seal moulding but also the fittings and how well the system is installed.

This is one reason why we have given all fittings a turned-over edge and have given still more fittings a stop bead. This gives us stable products which are better suited to withstand handling on site at the same time as the risk of skewed assembly falls.

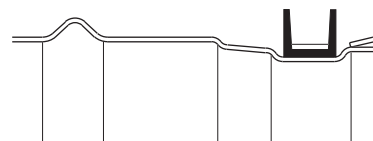

Turned-over edge design

The Safe system

1

Economy – Tightness

Present-day stringent demands for interior climate entail expensive air treatment. Leakage leads to uneconomical operation, adjustment difficulties and over-dimensioned equipment. For this reason, it is important that ventilation systems are very well sealed, to keep overall costs down. This is why official requirements for sealing vary with the size and use of systems.

2

3

Inspection/Testing

In order to make Safe comply with the requirements of sealing class D, we have constant inspection procedures where we do daily sampling. Inspection is done on goods received from sub-contractors and our own production of ducts and fittings.

Goods reception inspection complies with Swedish Standard for testing methods and batch acceptance levels. The inspection points include:

1. Inspection of seal moulding inner diameter. This is particularly important for ageing resistance of the rubber. The greater the load on the rubber, either stretching or pressure, the faster the rubber ages, causing brittleness and cracking.
2. The seal moulding profile is measured in a profile projector, where the dimensions of the seal moulding are checked against agreed tolerances.
3. The seal moulding material is tested by accelerated ageing in heat oven.

4

5

6

7

8

9

10

11

12

13

Manufacturing inspection is logged. The inspection includes a diameter check of ducts and fittings, a check of the groove where the seal moulding has been fixed, and a check of its fixing. Pressure testing is done in our air laboratory, to check the leakage flow from our products. This does not give the whole picture, however, so the best inspection of the Safe system is the pressure testing that The Swedish National and Testing Institute undertakes on randomly sampled products. In all these pressure tests, the Safe system has always exceeded the relevant sealing requirements.

Fittings

Products under the Safe insert and fittings with Safe seals under the Silencers, Dampers and measure units, and Isol inserts are included in the type approval for sealing class D. In addition, some fittings, under the Other circular products insert, are included.

A handful of fittings with the Safe seal can only manage up to tightness class C. This is marked on each of these products.

Fittings in this catalogue with a “U” in their designations have Safe seals, with only a few exceptions.

14

15

16

17

Degreased

Fittings can be supplied degreased on the inside, to order.

18

Dimensions

Almost all products in the Safe-programme can also be delivered in intermediate dimensions. For further information see page 13.

Negative pressure

At big negative pressure there is a risk for a ventilation system to collapse. This risk is greater the bigger dimensions you have.

In order to increase the strength of *the ducts* you can e.g. increase their sheet metal thickness. This is a simple way but the effect is rather small. It exists other ways with higher result. For bigger dimensions then the ducts may be stronger than the fittings.

In order to increase the strength of *the fittings* other ways than thicker sheet metal thickness are more suitable. Lindab has experience and knowledge about this and is willing to offer help at special cases. We can, as special, deliver duct systems that can withstand at least 5 000 Pa negative pressure.

The Safe system

Design

Our Safe seal system is based on a U-shaped profile of solid rubber. The seal moulding rests in a groove at the end of the fitting and is fixed with a steel strap.

As standard are Safe-fittings always supplied with an EPDM (ethylene-propylene rubber) seal moulding. The material has been chosen due to its long service life and the best possible resistance to ozone and UV radiation. It is also highly tolerant to temperature variations. Under normal conditions, the moulding can withstand:

-30 °C to +100 °C continuous
-50 °C to +120 °C intermittent

As special for installations which demand high temperature tolerance and somewhat higher oil resistance, Safe fittings can be supplied with a special silicone rubber moulding. This moulding is recognized by its blue colour. Mastic sealed fittings for higher temperatures are also produced with a more temperature resistant mastic. Temperature tolerance:

-70 °C to +150 °C continuous
-90 °C to +200 °C intermittent

When fittings are installed in ducts, the seal moulding lips will be bent backwards. This means that the seal will be better at withstanding negative pressure than positive pressure, since the negative pressure will tend to press the lips harder against the duct walls. The following pressure differences must not be exceeded, to cope with tightness class D.

Positive pressure in duct 3000 Pa
Negative pressure in duct 5000 Pa

Both Swedish and European standards allow a greater tolerance range between the duct and matching fittings as the diameter increases. In order to achieve maximum sealing for all dimensions, we have chosen to use successively bigger seal mouldings as duct dimensions increase.

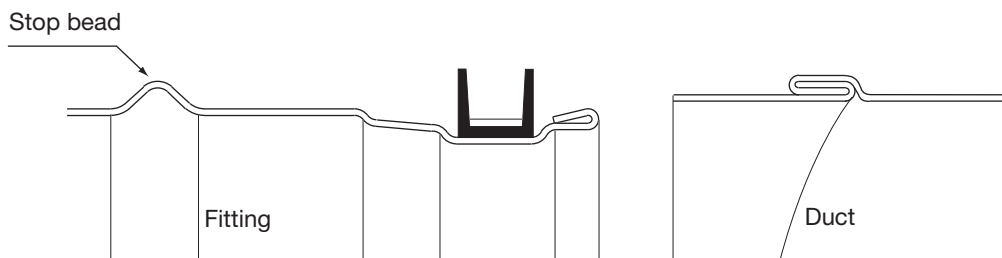

1

2

3

4

5

6

7

8

9

10

11

12

13

14

15

16

17

18

Lindab Safe® Click

Assemble easy and fast

1



2 "CLICK"



The new, innovative duct system from Lindab is based on a principle well known to you. A simple click is all it takes to assemble ducts and fittings. Save time and create a perfect ventilation solution.

The new system is installed quickly and improves working conditions especially where space is limited. Lindab Safe Click is based on our well-known, tested and documented Safe system. We just added simplicity. One click and the job is done.

Advantages during installation

- Quick assembly
- Minimised use of screws or rivets
- Easy to install, especially where space is limited
- Better ergonomics
- Assembling and adjusting is made easier

Advantages during use

- Fewer holes from screws or rivets in the duct system and thereby a tighter system
- Fewer sharp parts from screws or rivets in the duct
- The ducts are easier to clean and the risk of bacteria growth is reduced
- Based on our well-known, tested and well-documented Lindab Safe system
- Compatible with other systems



Assembly Instruction

Lindab Safe and Lindab Safe Click

The Lindab Safe and the Lindab Safe Click duct system are type-approved, as per certificate no. 1358/88 issued by SITAC and are subject to continuous production checks.

This means that the requirements for air tightness class D are met if ducts and fittings of the systems are used and if assembly is performed as per these instructions.

The products covered by the type approval are either specified on the delivery note or are supplied with the following labelling. Labelling can comprise a sticker or an embossing on the sheet metal



NOTE! The assembly methods described herein only cope with the forces from the “Static pressure limits” defined in EN 12237. Forces from other sources, e.g. gravity or wind, have to be dealt with using other means, e.g. suspensions or supports.

NOTE! If the system shall be tested for air tightness, this shall be done before integration and insulation so that there is an opportunity for inspection and taking action. Any complaints regarding air tightness will only be dealt with provided the system is fully accessible for inspection.

Joining systems (general characteristics)

Lindab Safe	Lindab Safe Click
Is joined with screws or blind rivets.	Is joined with snapping heels, below called notches. Is based on Lindab Safe.
Spans all dimensions.	Spans only a restricted number of dimensions. See table 2. For the other dimensions use Lindab Safe.
	<p>Lindab Safe Click can be complementary joined with screws or blind rivets.</p> <p>This may be done in order to:</p> <ul style="list-style-type: none"> • achieve a stronger joint • prevent a joint from twisting • join a Click product with a non-Click product • join a Click product with a non-Click product to create an openable joint.

Preparations for assembly

- Check that ducts and fittings to be used in the system are labelled as shown above.
- Store ducts and fittings in a well-ordered and weatherproof storage area to minimize the risk of damage. Do not use ducts or fittings that have been damaged in such a way that they jeopardise the air tightness or structural strength of the system.

Lindab Safe	Lindab Safe Click
<ul style="list-style-type: none"> • Cut ducts at right angles. Carefully remove any burrs from cut edges. Installation is easier and the risk of damaging the gasket is reduced if there are no burrs. Also cut away the two needles created from the fold. 	<ul style="list-style-type: none"> • Cut ducts at right angles. This is an uncompromisable demand for Lindab Safe Click. Carefully remove any burrs from cut edges. Installation is easier and the risk of damaging the gasket is reduced if there are no burrs. Also cut away the two needles created from the fold.
	<ul style="list-style-type: none"> • If a duct is cut – make notches around its circumference. See table 1 and 2.
<ul style="list-style-type: none"> • Carefully seal any holes left by measurements, removed screws, blind rivets, etc. 	<ul style="list-style-type: none"> • Carefully seal any holes left by measurements etc.

Table 1. Size and location of notches

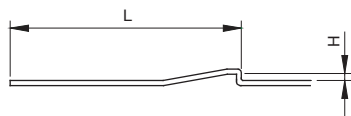

Ø [mm]	Click Pliers		L [mm]
	40.1	60.1	
80–224	H _{min} [mm] 2,0	H _{min} [mm] –	30,5–32,5
250–315	H _{min} [mm] –	H _{min} [mm] 2,5	50,5–52,5

Table 2. Number of fasteners and notches

Ø [mm]	Lindab Safe	Lindab Safe Click	
		Click Pliers	
		40.1	60.1
	Minimum number of fasteners required to achieve sufficient strength.	Recommended number of notches required to achieve sufficient strength.	
63	2	–	–
80–112	2	2	–
125–160	3	4	–
180–224	3	4	–
250–315	4	–	4
355–630	4	–	–
710–1250	6	–	–
	Depending on the means of suspension, a larger number of fasteners than this may be required to achieve sufficient structural strength of a duct system.	Depending on the means of suspension, a larger number of notches than this may be required to achieve sufficient structural strength of a duct system. A greater number of notches makes it harder to assemble the parts.	

Assembly

Lindab Safe	Lindab Safe Click
1. Start by inserting the turned-over edge of the fitting into the duct.	1. Insert the fitting's turned-over edge into the duct.
2. Check that the first lip of the gasket is in contact with the edge of the duct all the way around and sticks straight out so that the lip is not twisted in one direction or the other.	2. Check that the gasket's first lip is in contact with the duct's edge all the way around and points straight out so that the lip is not twisted in any direction.
3. Push the end of the fitting into the duct. Twisting the fitting slightly aids insertion.	3. Push the first part of the fitting into the duct to just before the notches. Twisting the fitting slightly aids insertion.
4. Secure the fitting in the duct using self-tapping screws or airtight blind rivets. NOTE! Use only the types allowed by Lindab when going for tightness class C or D. See table 3.	4. Push the rest of the fitting into the duct and over the notches. Bend the fitting or duct back and forward slightly in order not to pass all notches at the same time aids insertion.
5. Fasteners should be positioned 10–15 mm from the end of the duct to prevent damage to the gasket.	5. The fitting is secured to the duct when the fitting's end has snapped behind all the notches.
6. Always position fasteners at the present largest radial gap between fitting and duct. Be sure to achieve an even distribution around the circumference.	6. After assembly it's possible to rotate the fitting.

Lindab Safe

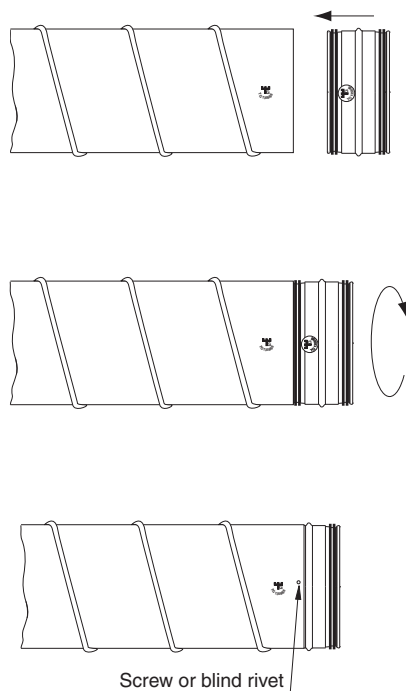

Lindab Safe Click

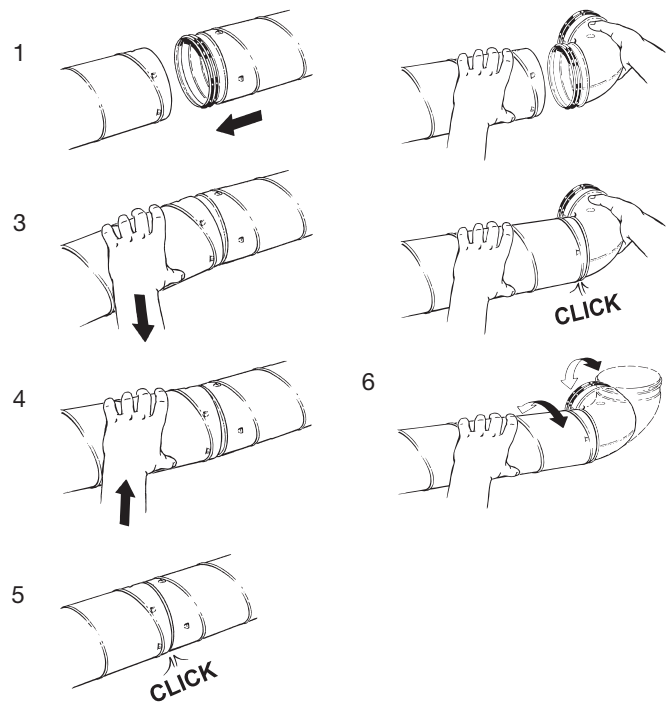
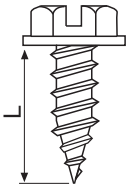
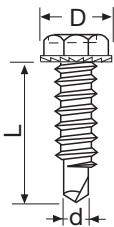
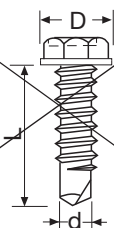



Table 3. Allowed and banned screws and blind rivets

	<p>Screw with sharp tip</p> <ul style="list-style-type: none"> • Very tight • Strong since it forms a collar in the thin sheet metal 	<p>Allowed by Lindab</p>
	<p>Screw with reduced drill tip</p> <ul style="list-style-type: none"> • Very tight • Strong since it only drills off a small part of the thin sheet metal 	<p>Allowed by Lindab</p>
	<p>Screw with drill tip</p> <ul style="list-style-type: none"> • Not tight • Weak since it drills off a big part of the thin sheet metal 	<p>Banned by Lindab</p>
	<p>Pressure-tight blind rivet</p> <ul style="list-style-type: none"> • Very tight • Strong • Very laborious to install 	<p>Allowed by Lindab</p>
	<p>Blind rivet</p> <ul style="list-style-type: none"> • Not tight if the inner splint falls out • Strong • Laborious to install 	<p>Banned by Lindab</p>

Hints!

Turning and bending the fitting slightly as you insert it into the duct aids assembly and removal.

If ducts and fittings are round, assembly is much easier. Lindab has placed high demands on roundness during the design and production stages, but large heavy fittings in particular have a tendency to be slightly oval because of their weight. These often become round when suspended, which is why you should use the brackets to make the components round and in this way simplify assembly.

Carefully tapping the surface of the duct with your hand normally makes assembly a lot easier, as it reduces the friction between duct and fitting, and the fitting tries to move to the right side if there are burrs and irregularities.

When cutting, be sure to remove burrs properly. Also cut away the two needles created from the fold.

For larger dimensions, Lindab has moved the gasket away from the edge, which makes assembly much easier.

If you have to reinstall a product, take care to seal old holes from screws or blind rivets which can cause leaks and noise.

Products with special seals

Some fittings, such as the collar saddle PSU, T-pieces TSTCU, TSTU and take-offs ILRU, ILU, ILF, have one more connection than Lindab Safe or Lindab Safe Click. This connection must be sealed so that they definitely meet the requirements for air-tightness class C or D. Sealing material used must be durable and permanently elastic.

Products without Click

Some fittings, such as the slide-in female coupling SMFU, the end caps EPF and ESU and of course the cleaning covers EPFH, ESHU, KCU and KCIVU, do not have any Click function in order to make them easier to remove.

Use of products other than Lindab Safe or Lindab Safe Click

Products that do not formally fulfil the requirements for air tightness class C or D may only be used to a small extent. If such items are used, they must be carefully checked with regard to seal design and strength. They must be sealed so that they definitely meet the requirements for air-tightness class C or D. Sealing material used must be durable and permanently elastic.

To join parts temporarily to check if length of duct or system run is all right.	
Lindab Safe	Lindab Safe Click
<p>Solution:</p> <ol style="list-style-type: none"> 1 Join together to check. 2 Then take apart – and cut if necessary the duct length. 3 Join together with screws or blind rivets. 	<p>Solution 1:</p> <ol style="list-style-type: none"> 1 Use a duct without notches in the end/ends. 2 Join together to check. 3 Then take apart – and cut if necessary the duct length. 4 Make notches in the duct. 5 Click-join together. <p>Solution 2:</p> <ol style="list-style-type: none"> 1 Use a duct with notches in the end/ends. 2 Join together to check – but don't join the parts completely so they click together. 3 Then take apart – and cut if necessary the duct length and make new notches. 4 Click-join together.

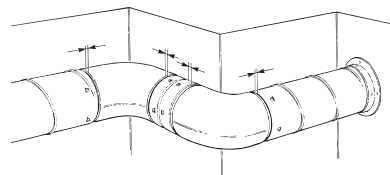

To lengthwise adjust joined products instead of cutting the duct.

Lindab Safe

Lindab Safe Click

Solution:

- 1 Use products with sliding property. E.g. slide-in coupling SNPU or slide-in female coupling SMFU.
- 2 Join together with screws or blind rivets.

Solution:

- 1 Use products with sliding property. E.g. slide-in coupling SNPU or slide-in female coupling SMFU.
- 2 Join together with screws or blind rivets.

Slide-in coupling

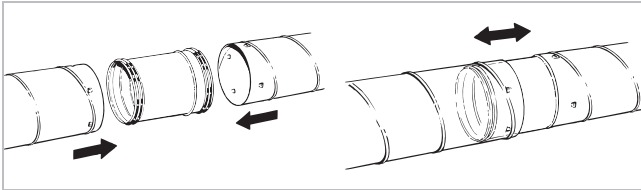

Slide-in female coupling

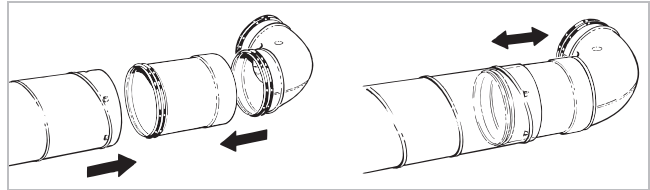

The joint must be locked

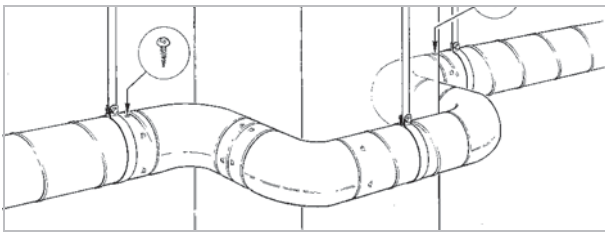

In situations where the mounting must be locked, e.g. when a bend is mounted to a duct and it twists downwards the floor. Mount the first hanger and mount the bend, then lock the joint with a screw or blind rivet.

Corners out of angle and curved walls

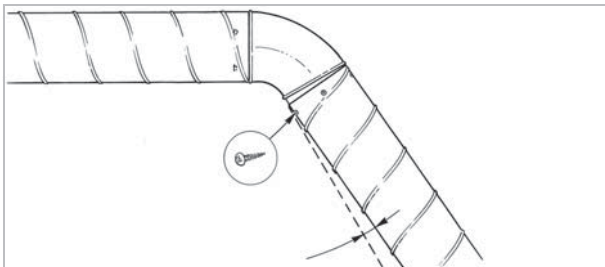

Mount the next piece of duct at an angle, but make sure that the rubber sealant is not visible. Put screws or blind rivets where the notches have not clicked in position.

Cutting duct with the SR Cutter

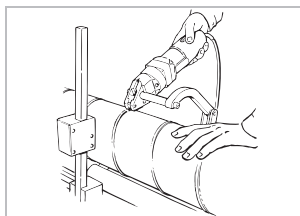
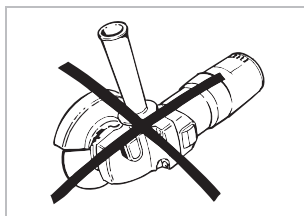
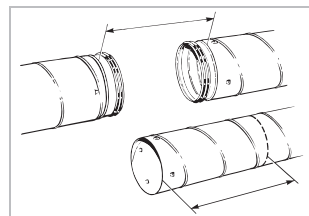

Suspension

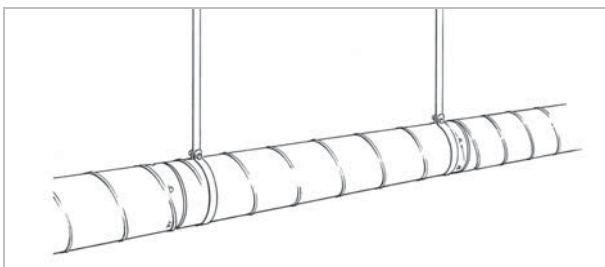

Mount the hangers in a straight line and as close to every joint as possible. Fix with an extra screw when needed for extra stability.

Dismantling

To separate joined products.	
Lindab Safe	Lindab Safe Click
<p>Solution:</p> <ol style="list-style-type: none"> 1 Unscrew the screws or drill away the blind rivets. 2 Twist the product loose. 3 The fitting will now have leaking holes but can be reused if these holes are carefully sealed off with mastic or tape. 	<p>Solution:</p> <ol style="list-style-type: none"> 1 Drill a 5 mm hole in the duct 4 mm behind the notch with the drill angled backward and 2 turn in the same moment the drill back so the fitting and duct are separated somewhat from each other. With the right technique the fitting remains undamaged and can be reused. 3 Repeat if necessary at more notches. 4 Twist the product loose. 5 Cut away the drilled through duct end.

Lindab Safe Click

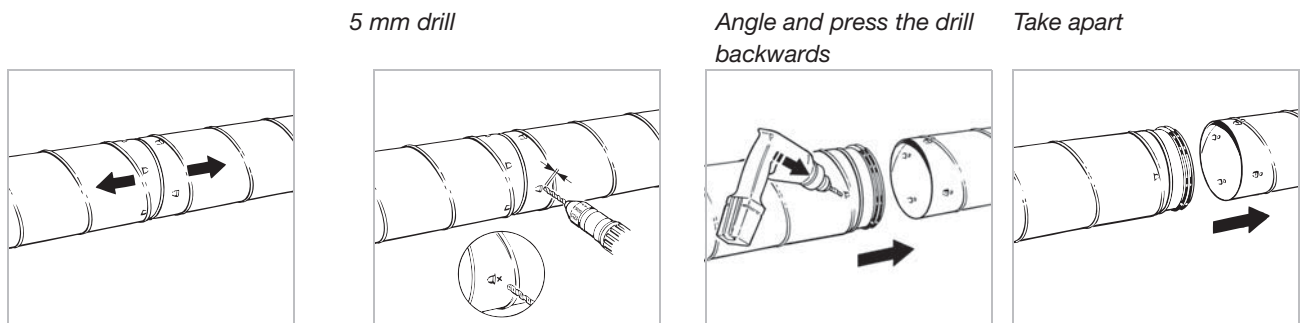



Dimensions

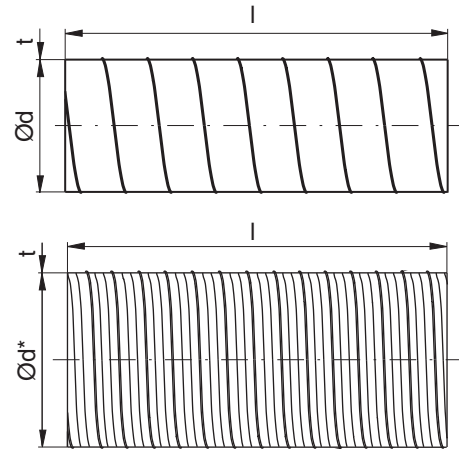

Description

Circular duct.

Ducts are always produced locally and can therefore have different thicknesses and other specifications per country.

The ducts can be produced both with and without click function (notches).

Please specify when ordering.

Ød std nom	O πd m	A $\pi d^2/4$ m ²	t std mm	l std mm	ml std kg/m
63	0,198	0,003	0,5	3000	0,89
80	0,251	0,005	0,45	3000	0,91
100	0,314	0,008	0,45	3000	1,14
112	0,352	0,010	0,5	3000	1,42
125	0,393	0,012	0,45	3000	1,41
140	0,440	0,015	0,5	3000	1,76
150	0,471	0,018	0,5	3000	1,89
160	0,503	0,020	0,5	3000	2,02
180	0,565	0,025	0,5	3000	2,26
200	0,628	0,031	0,5	3000	2,56
224	0,704	0,039	0,6	3000	3,42
250 *	0,785	0,049	0,5	3000	3,18
280	0,880	0,062	0,55	3000	3,92
300 *	0,942	0,071	0,55	3000	4,20
315 *	0,990	0,078	0,55	3000	4,41
355 *	1,115	0,099	0,55	3000	4,96
400 *	1,257	0,126	0,55	3000	6,01
450 *	1,414	0,159	0,7	3000	8,60
500 *	1,571	0,196	0,7	3000	9,54
560 *	1,759	0,246	0,8	3000	12,2
600 *	1,885	0,283	0,7	3000	13,1
630 *	1,979	0,312	0,7	3000	12,0
710 *	2,231	0,396	0,8	3000	15,5
800 *	2,513	0,503	0,8	3000	17,4
900 *	2,827	0,636	0,9	3000	21,7
1000 *	3,142	0,785	0,9	3000	24,1
1120 *	3,519	0,985	0,9	3000	27,0
1250 *	3,927	1,227	0,9	3000	30,2
1400 *	4,398	1,539	1,25	2400	48,0
1500 *	4,712	1,767	1,25	2400	51,4
1600 *	5,027	2,011	1,25	2400	54,8

Ordering example

Product	SR	200	3000	CLIC
Dimension Ød				
Length l				
Type				

* With outturned stiffening corrugation.

Technical data

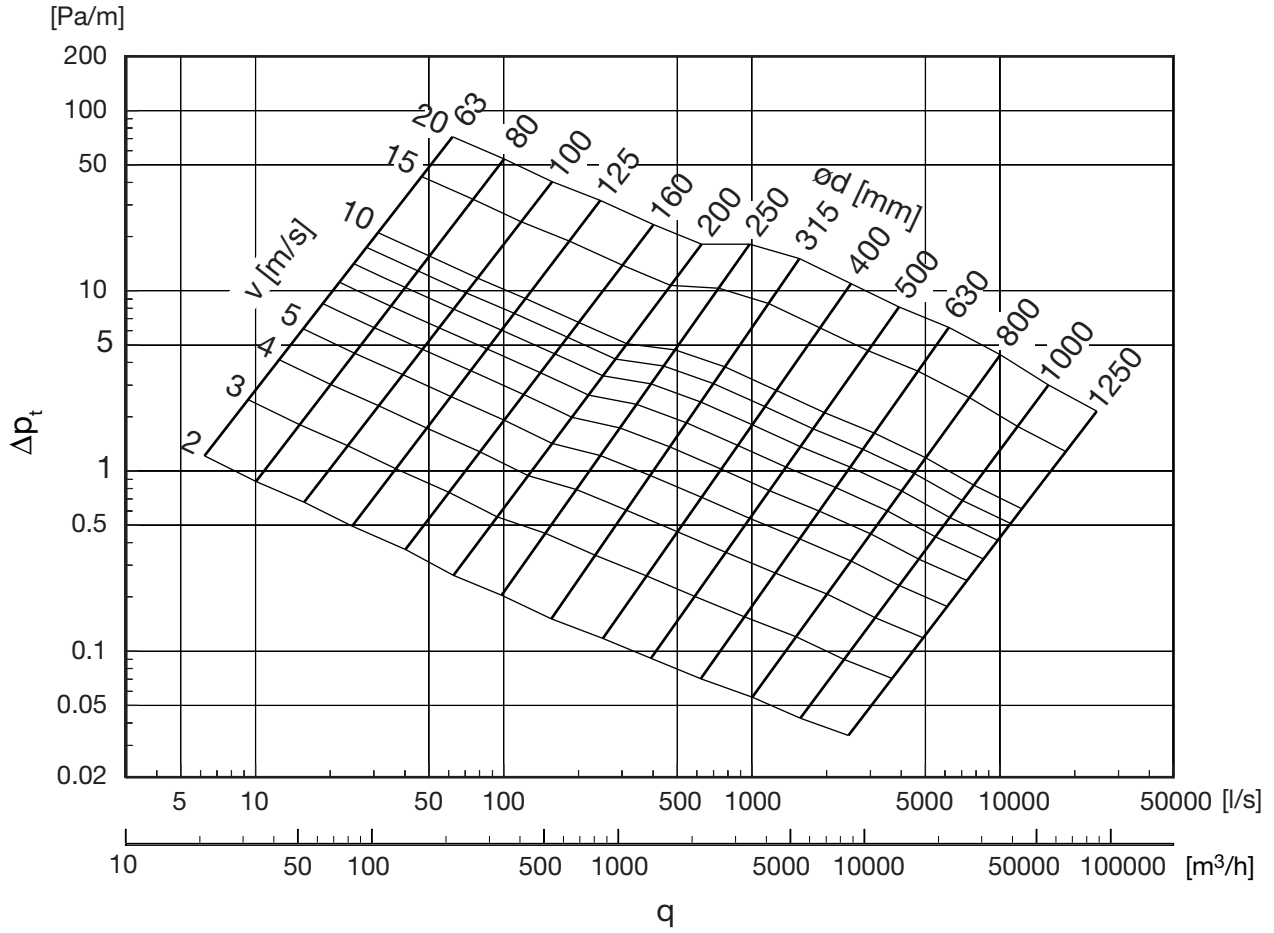

- 1
- 2
- 3
- 4
- 5
- 6
- 7
- 8
- 9
- 10
- 11
- 12
- 13
- 14
- 15
- 16
- 17
- 18

Technical data

Special versions

We can supply ducts with the following special designs:

- In intermediate dimensions, see page 15.
- Extra tight, with nitrile rubber seal in the lock seam
- In other sheet metal thicknesses

Extra tight, with seam seal

When extremely good sealing is required in the spiral seam, the ducts can also be supplied with a special rubber seal in the seam.

This seal is very effective at stopping leakage of vegetable oils and greases, and most petroleum products including white spirit.

Other sheet metal thicknesses

If extra stability is needed in ducts, because of high negative pressure etc., they can be supplied with thicker sheet metal than standard. Remember that the thickness increase always reduces the inner diameter. Fittings for such special ducts must be specified separately and sometimes have to be made specially.

Reinforcement corrugations

Ducts of Ø250 mm and above are normally given stiffening corrugations to increase radial stiffness.

Strength

Positive pressure

In case of high positive pressure, the seal moulding lips will first start to whistle. At considerably higher pressure, the joints between the ducts will be forced apart. If you manage to fix the connections very well, the ducts will burst at their seams at even higher pressure. The high pressures needed for this to happen are not relevant to ventilation installations.

Negative pressure

In installations with high negative pressure, there is a risk that the ducts could collapse.

This phenomenon is referred to as buckling, and can suddenly happen at the weakest point in the system. Buckling wanders along the duct, which can be completely flattened. The weakest point is frequently a "transport dent" on a duct. For this reason, only use undamaged ducts in systems which are close to the critical pressure!

Sealing

The ability of the seal moulding to seal is different from these pressures, and is noted on page 45.

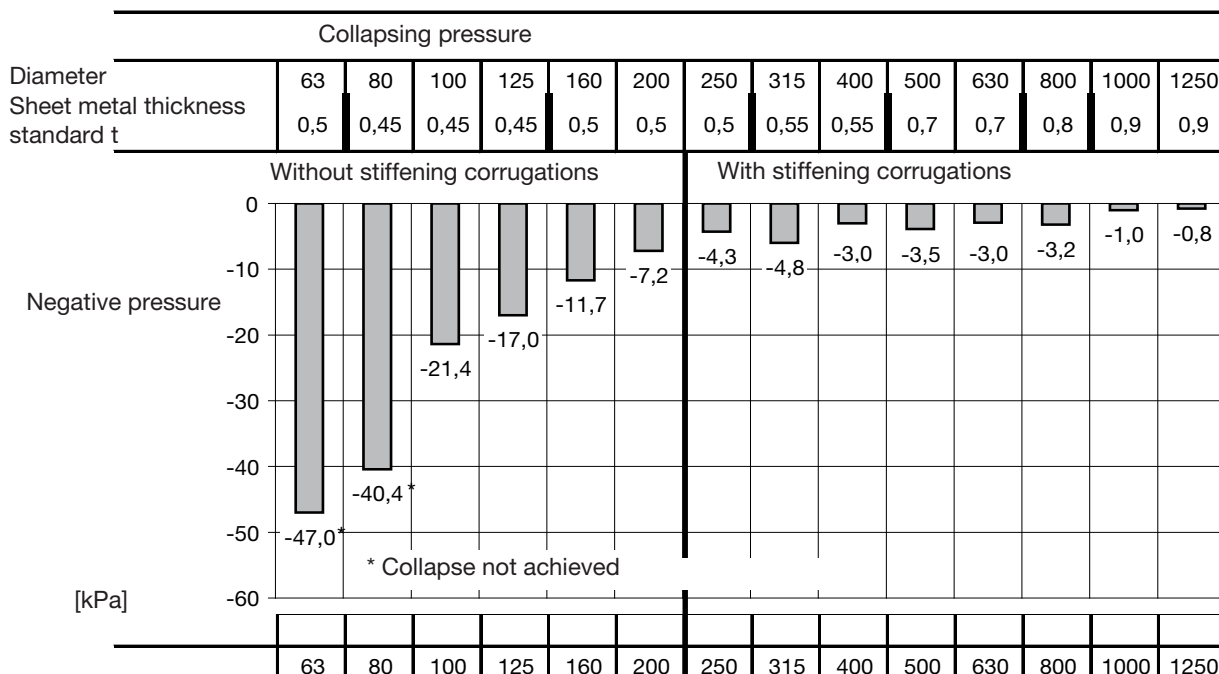



Description

Capped circular duct.

Ducts are always produced locally and can therefore have different thicknesses and other specifications per country.

The ducts can be produced both with and without click function (notches).

Please specify when ordering.

Dimensions

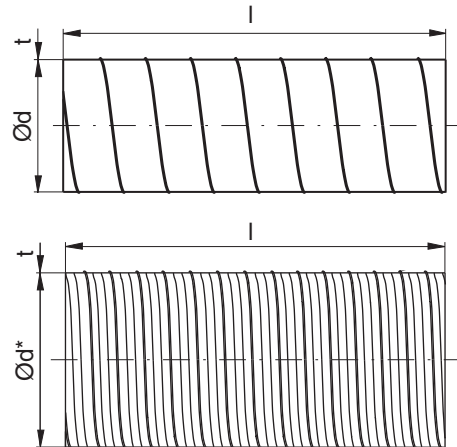

Ød std nom	O πd m	A $\pi d^2/4$ m ²	t std mm	l std mm	ml std kg/m
63 ¹	0,198	0,003	0,5	3000	0,89
80 ¹	0,251	0,005	0,45	3000	0,91
100 ¹	0,314	0,008	0,45	3000	1,14
112	0,352	0,01	0,5	3000	1,42
125 ¹	0,393	0,012	0,45	3000	1,41
140	0,44	0,015	0,5	3000	1,76
150	0,471	0,018	0,5	3000	1,89
160 ¹	0,503	0,02	0,5	3000	2,02
180	0,565	0,025	0,5	3000	2,26
200 ¹	0,628	0,031	0,5	3000	2,56
224	0,704	0,039	0,6	3000	3,42
250 ^{*1}	0,785	0,049	0,5	3000	3,18
280	0,88	0,062	0,55	3000	3,92
300 [*]	0,942	0,071	0,55	3000	4,26
315 ^{*1}	0,99	0,078	0,55	3000	4,41
355 [*]	1,115	0,099	0,55	3000	4,96
400 ^{*2}	1,257	0,126	0,55	3000	6,01
450 [*]	1,414	0,159	0,7	3000	8,60
500 ^{*2}	1,571	0,196	0,7	3000	9,54
560 [*]	1,759	0,246	0,8	3000	12,2
600 [*]	1,885	0,283	0,7	3000	13,1
630 ^{*2}	1,979	0,312	0,7	3000	12,0
710 [*]	2,231	0,396	0,8	3000	15,5
800 ^{*2}	2,513	0,503	0,8	3000	17,4
900 [*]	2,827	0,636	0,9	3000	21,7
1000 ^{*2}	3,142	0,785	0,9	3000	24,1
1120 [*]	3,519	0,985	0,9	3000	27,0
1250 ^{*2}	3,927	1,227	0,9	3000	30,2

Ordering example

Product	SRL	250	3000	CLIC
Dimension Ød				
Length l				
Type				

* With outturned stiffening corrugations.

¹ With blue plastic caps.

² With transparent plastic hoods.

Technical data

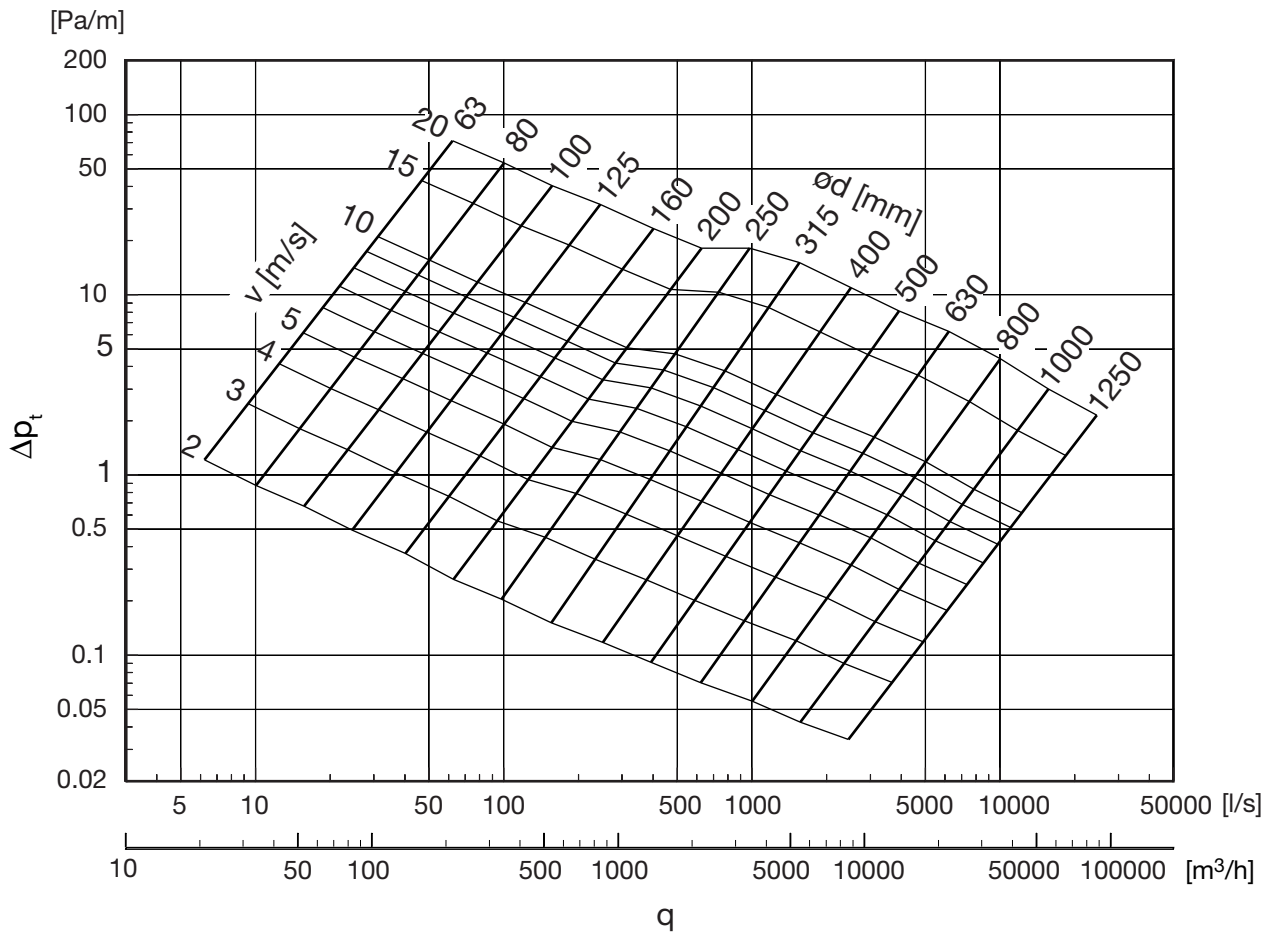

Technical data

Special versions

We can supply ducts with the following special designs:

- In intermediate dimensions, see page 15.
- Extra tight, with nitrile rubber seal in the lock seam
- In other sheet metal thicknesses

Extra tight, with seam seal

When extremely good sealing is required in the spiral seam, the ducts can also be supplied with a special rubber seal in the seam.

This seal is very effective at stopping leakage of vegetable oils and greases, and most petroleum products including white spirit.

Other sheet metal thicknesses

If extra stability is needed in ducts, because of high negative pressure etc., they can be supplied with thicker sheet metal than standard. Remember that the thickness increase always reduces the inner diameter. Fittings for such special ducts must be specified separately and sometimes have to be made specially.

Reinforcement corrugations

Ducts of Ø250 mm and above are normally given stiffening corrugations to increase radial stiffness.

Strength

Positive pressure

In case of high positive pressure, the seal moulding lips will first start to whistle. At considerably higher pressure, the joints between the ducts will be forced apart. If you manage to fix the connections very well, the ducts will burst at their seams at even higher pressure. The high pressures needed for this to happen are not relevant to ventilation installations.

Negative pressure

In installations with high negative pressure, there is a risk that the ducts could collapse.

This phenomenon is referred to as buckling, and can suddenly happen at the weakest point in the system. Buckling wanders along the duct, which can be completely flattened. The weakest point is frequently a "transport dent" on a duct. For this reason, only use undamaged ducts in systems which are close to the critical pressure!

Sealing

The ability of the seal moulding to seal is different from these pressures, and is noted on page 45.

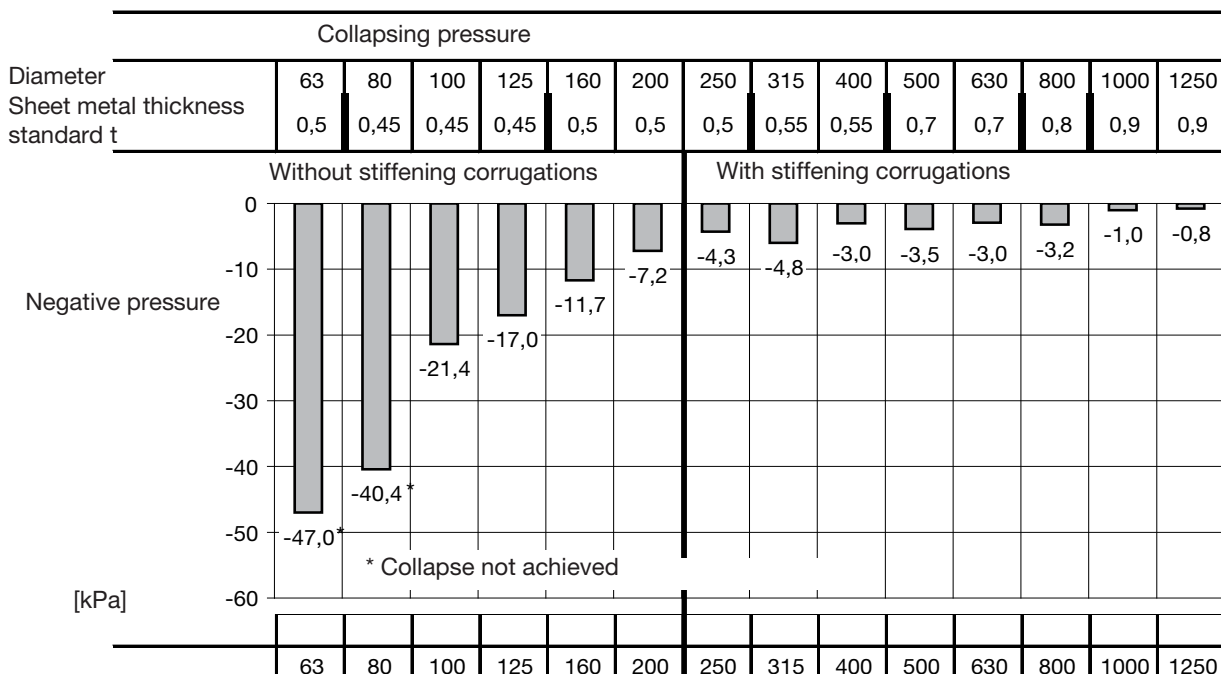



Dimensions

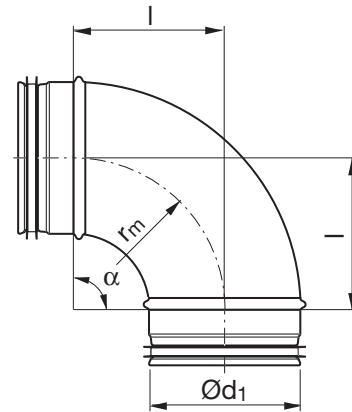

$$r_m \approx 1 \cdot d_1$$

Description

Pressed and seam welded bend.

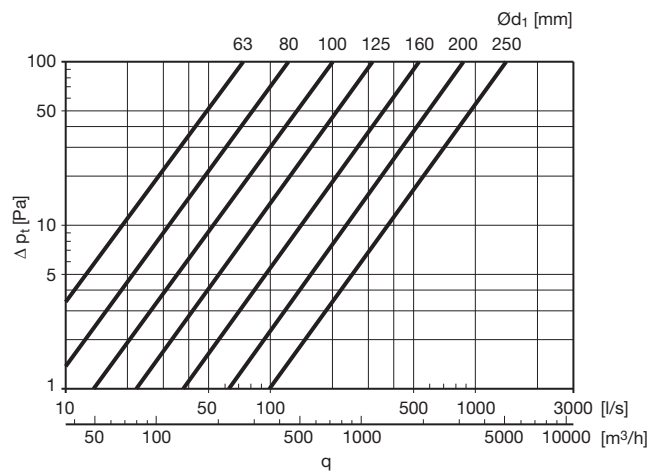

$\text{O} d_1$ nom	l mm	m kg
63	110	0,20
80	105	0,26
100	100	0,31
112	120	0,39
125	125	0,48
140	135	0,66
150	150	0,66
160	160	0,62
180	180	1,02
200	200	1,12
224	225	1,33
250	242	1,77

Ordering example

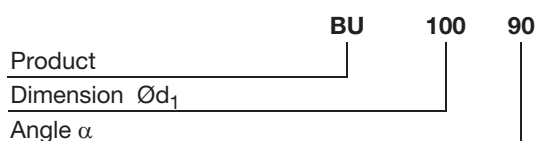



Dimensions

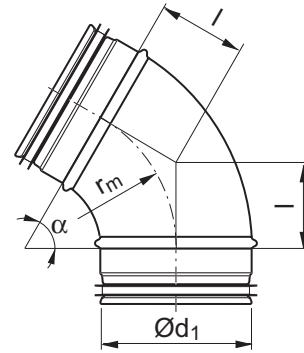

$$r_m \approx 1 \cdot d_1$$

Description

Pressed and seam welded bend.

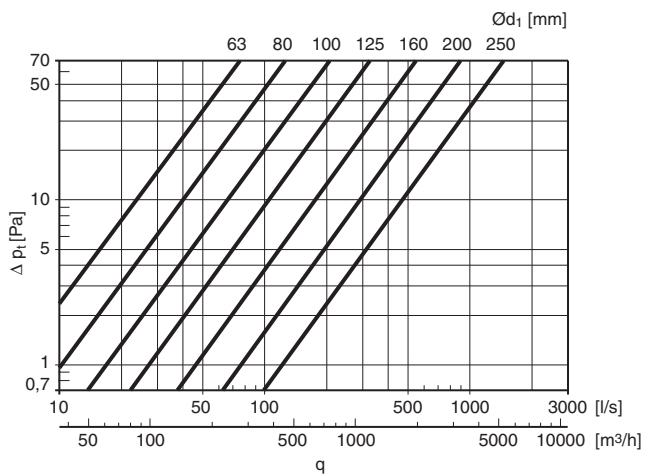

Ød ₁ nom	l mm	m kg
63	64	0,30
80	58	0,32
100	58	0,33
112	69	0,37
125	72	0,33
140	78	0,51
150	87	0,50
160	92	0,56
180	104	0,79
200	115	0,82
224	130	0,95
250	144	1,12

Ordering example

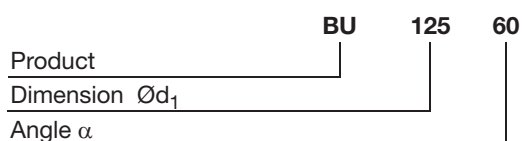



Dimensions

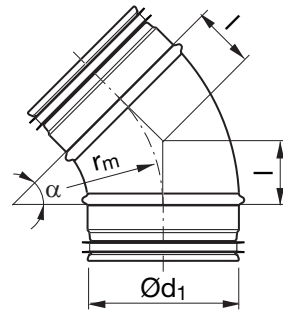

$$r_m \approx 1 \cdot d_1$$

Description

Pressed and seam welded bend.

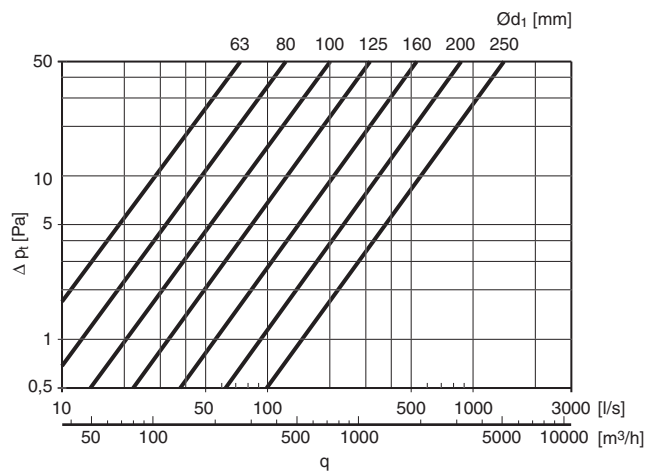

$\text{O} d_1$ nom	l mm	m kg
63	46	0,16
80	41	0,17
100	41	0,21
112	81	0,24
125	52	0,29
140	56	0,43
150	62	0,42
160	66	0,48
180	76	0,65
200	83	0,80
224	93	0,82
250	103	1,05

Ordering example

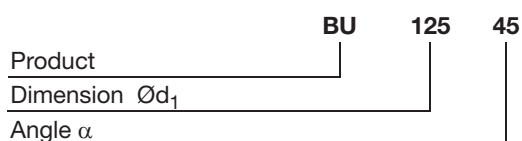



Dimensions

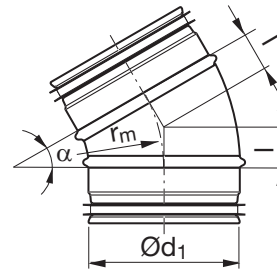

$$r_m \approx 1 \cdot d_1$$

Description

Pressed and seam welded bend.

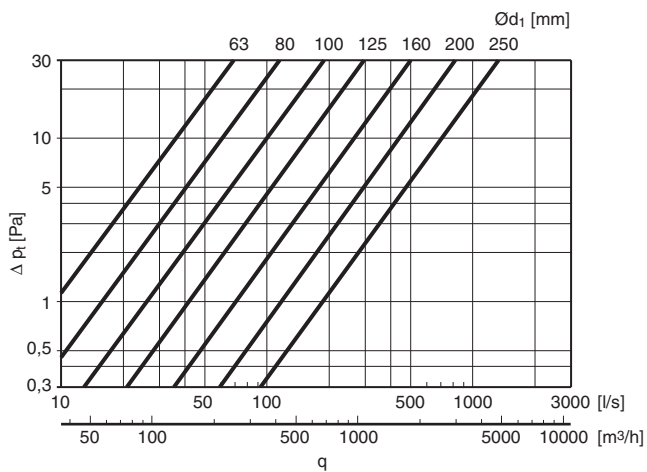

Ød ₁ nom	l mm	m kg
63	29	0,13
80	27	0,15
100	27	0,18
112	30	0,21
125	33	0,20
140	36	0,36
150	40	0,35
160	43	0,32
180	48	0,51
200	54	0,62
224	60	0,72
250	67	0,91

Ordering example

Product **BU**
 Dimension Ød₁ **125**
 Angle α **30**



Dimensions

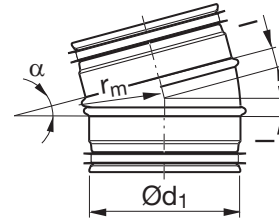

$$r_m \approx 1 \cdot d_1$$

Description

Pressed and seam welded bend.

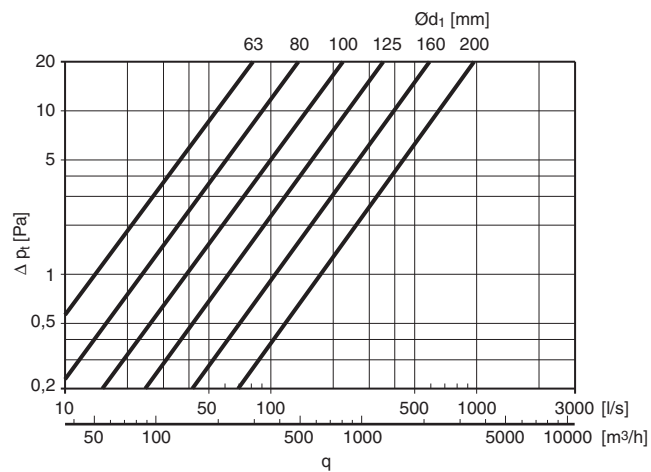

$\text{O}d_1$ nom	l mm	m kg
63 *	14	0,09
80 *	13	0,11
100	13	0,15
112 *	25	0,29
125	16	0,18
140 *	18	0,29
150 *	20	0,27
160	21	0,24
180 *	24	0,37
200	26	0,35
224 *	30	0,56

* Segmented and lockseamed

Ordering example

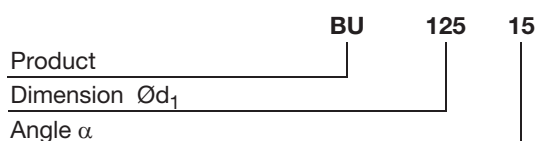



Dimensions

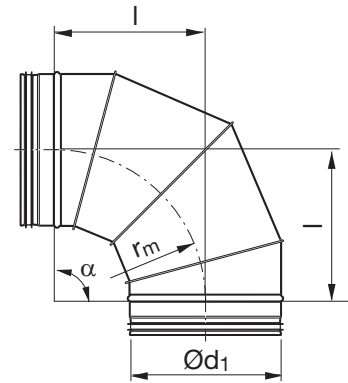

$$r_m \approx 1 \cdot d_1$$

Description

Segmented and lockseamed bend.

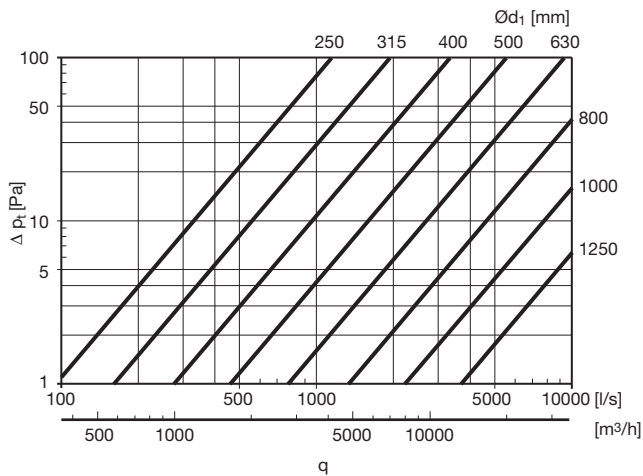

O_{d_1} nom	l mm	m kg	Number of segments
250	250	2,20	4
280	280	2,50	4
300	300	2,7	4
315	315	3,00	4
355	355	3,75	4
400	400	5,64	4
450	450	7,00	4
500	500	8,20	4
560	560	10,1	4
600	600	11,7	4
630	630	12,9	4
710	710	19,8	4
800	800	26,0	4
900	900	33,6	4
1000	1000	42,0	5
1120	1120	52,6	5
1250	1250	64,0	5

Ordering example

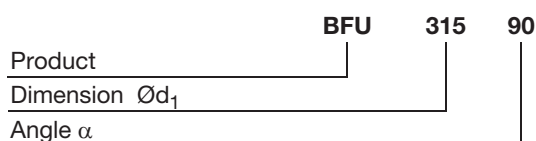



Dimensions

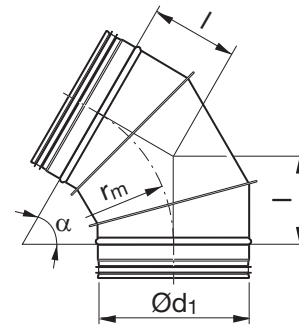

$$r_m \approx 1 \cdot d_1$$

Description

Segmented and lockseamed bend.

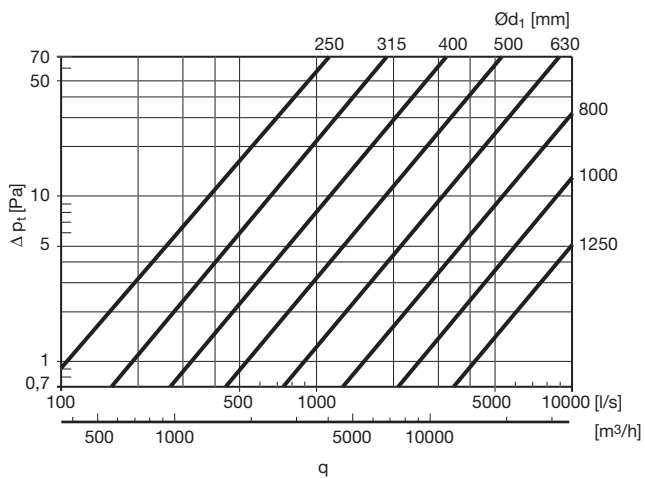

O_{d_1} nom	l mm	m kg
250	144	1,48
280	162	1,80
300	173	2,00
315	182	2,20
355	205	2,80
400	231	3,47
450	260	4,70
500	289	6,00
560	323	7,40
600	346	8,60
630	364	9,20
710	410	11,3
800	462	14,8
900	520	19,3
1000	577	24,2
1120	647	30,1
1250	722	36,6

Ordering example

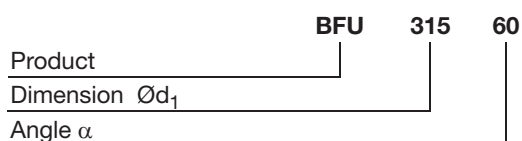



Dimensions

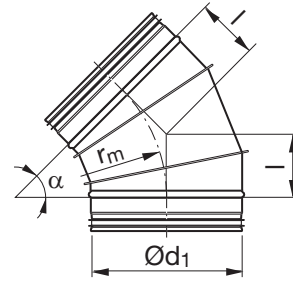

$$r_m = 1 \cdot d_1$$

Description

Segmented and lockseamed bend.

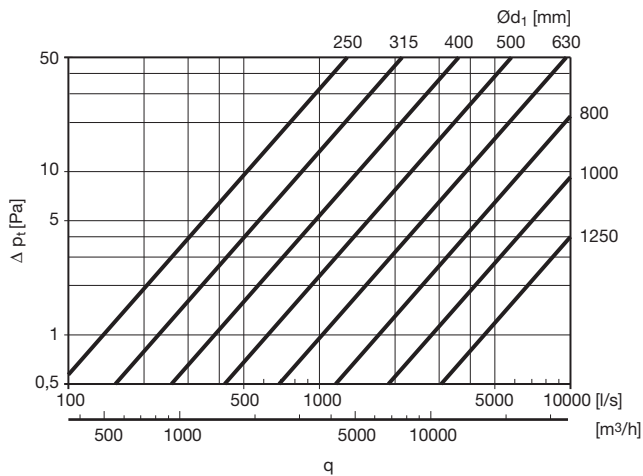

Ød ₁ nom	l mm	m kg
250	104	1,26
280	116	1,54
300	124	1,77
315	130	1,90
355	147	2,26
400	166	2,96
450	186	4,00
500	207	4,90
560	232	6,10
600	249	6,80
630	261	7,49
710	294	11,3
800	331	15,0
900	373	16,8
1000	414	19,5
1120	464	28,5
1250	518	38,0

Ordering example

Product **BFU**
 Dimension Ød₁ **250**
 Angle α **45**



Dimensions

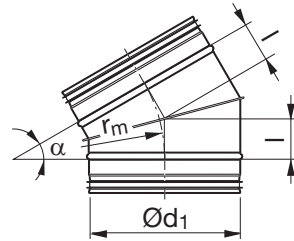

$$r_m = 1 \cdot d_1$$

Description

Segmented and lockseamed bend.

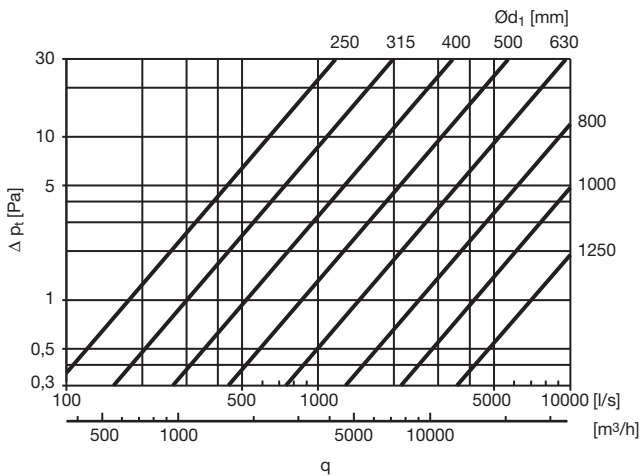

$\text{Ø}d_1$ nom	l mm	m kg
250	67	1,00
280	75	1,10
300	80	1,30
315	84	1,42
355	95	1,70
400	107	2,27
450	121	3,00
500	134	3,70
560	150	4,60
600	161	5,10
630	169	5,60
710	190	8,60
800	214	11,0
900	241	10,9
1000	268	13,4
1120	300	16,1
1250	335	19,0

Ordering example

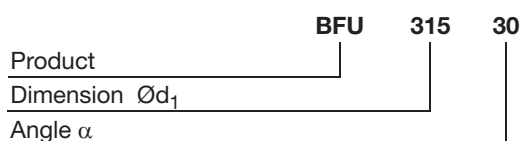



Dimensions

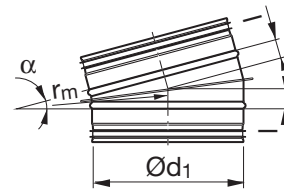

$$r_m = 1 \cdot d_1$$

Description

Segmented and lockseamed bend.

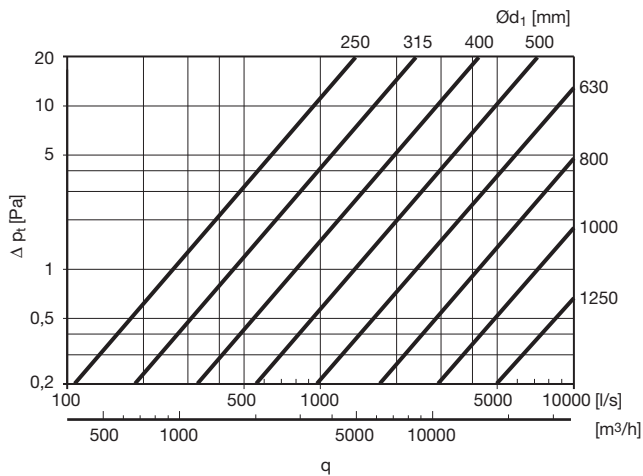

Ød ₁ nom	l mm	m kg
250	33	0,65
280	37	0,77
300	39	0,85
315	41	0,91
355	47	1,41
400	53	1,70
450	59	2,20
500	66	2,65
560	74	3,30
600	79	3,70
630	83	4,00
710	93	5,80
800	105	7,00
900	118	8,50
1000	132	10,4
1120	147	12,5
1250	165	14,5

Ordering example

Product	BFU	400	15
Dimension Ød ₁			
Angle α			



Dimensions

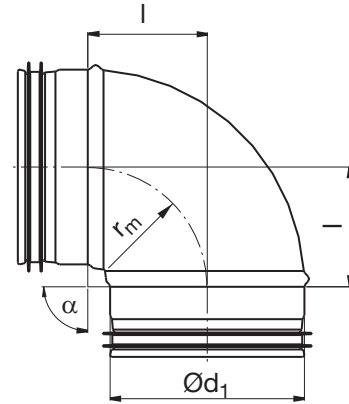

$$r_m \approx 0,6 \cdot d_1$$

Description

Pressed and seam welded bend with short installation length.

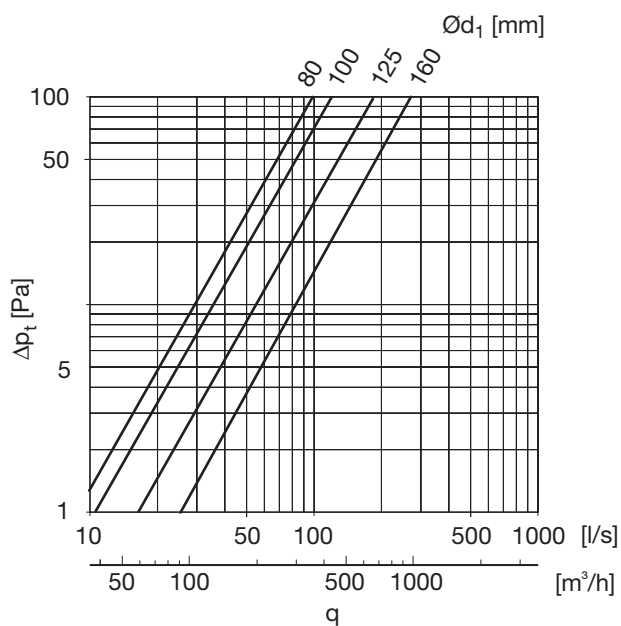

$\varnothing d_1$ nom	l mm	m kg
80	80	0,14
100	62	0,22
125	79	0,31
160	94	0,50

Ordering example

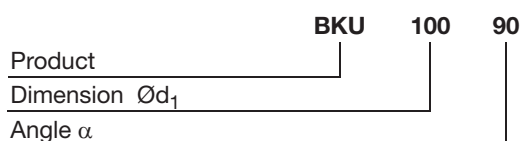



Dimensions

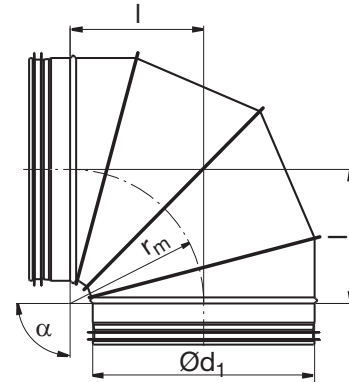

$$r_m \approx 0,6 \cdot d_1$$

Description

Segmented and lockseamed bend with short installation length.

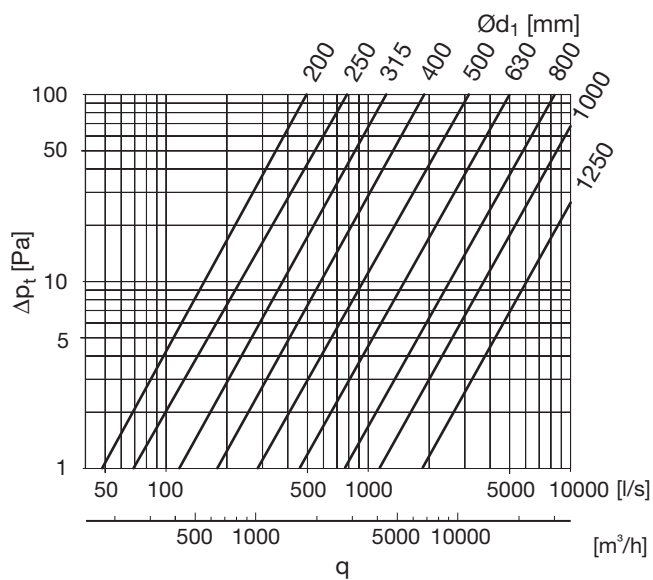

$\text{O} d_1$ nom	l mm	m kg
200	158	1,18
250	180	1,64
315	220	2,49
400	255	3,61
500	315	6,30
630	397	9,45
800	470	18,0
1000	570	26,9
1250	695	38,8

Ordering example

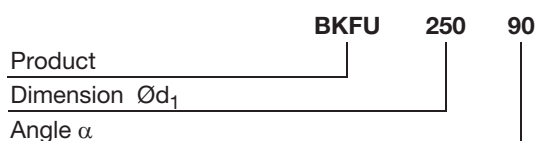



Dimensions

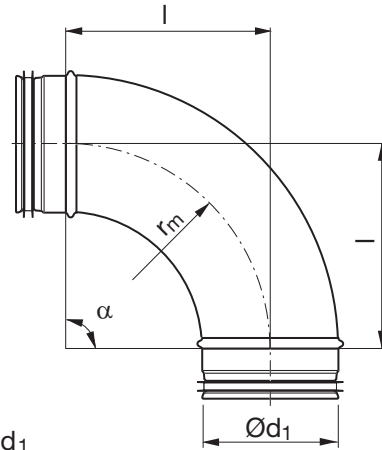

$$r_m \approx 1,5 \cdot d_1$$

Description

Pressed and seam welded bend.

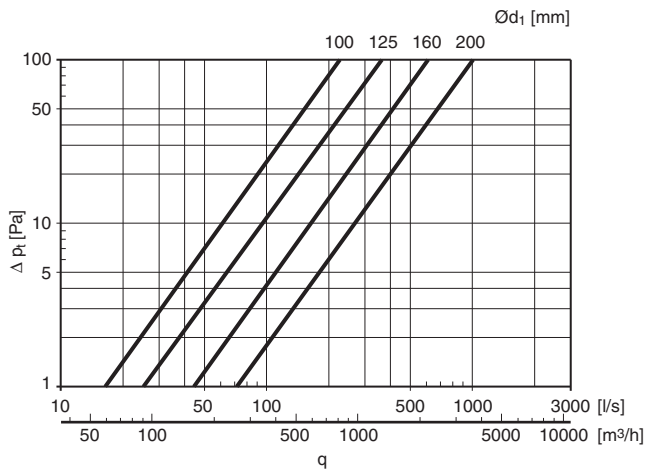

Ød ₁ nom	l mm	m kg
100	150	0,50
125	190	0,79
150	225	0,95
160	240	1,14
180	270	1,50
200	300	1,55

Ordering example

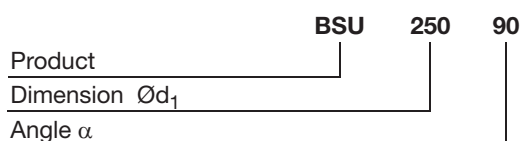



Dimensions

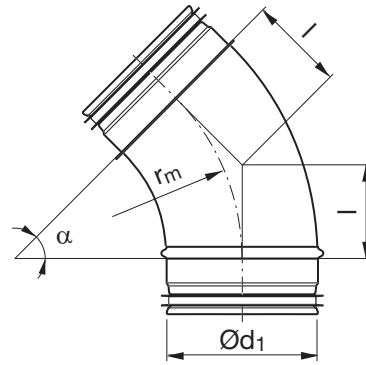

$$r_m \approx 1,5 \cdot d_1$$

Description

Pressed and seam welded bend.

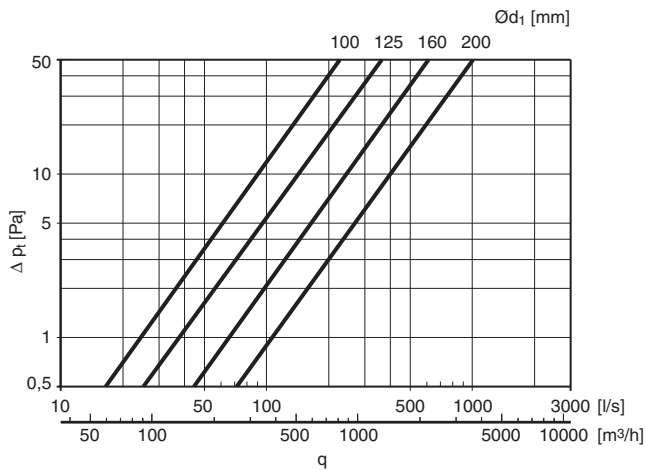

$\text{Ø}d_1$ nom	l mm	m kg
100	62	0,26
125	79	0,41
150	93	0,49
160	100	0,59
180	112	0,77
200	124	0,82

Ordering example

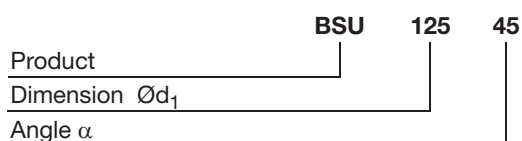



Dimensions

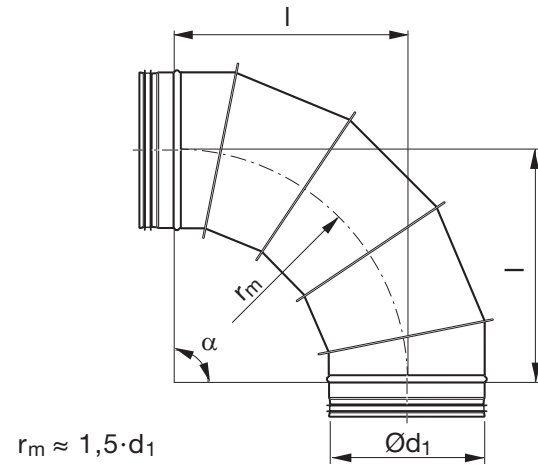

Description

Segmented and lockseamed bend.

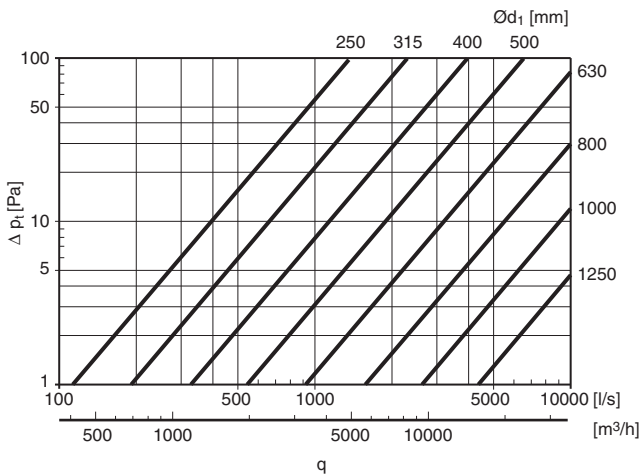

$\text{O} d_1$ nom	l mm	m kg
250	375	2,70
280	420	3,33
300	450	3,60
315	473	4,20
355	533	4,60
400	600	8,30
450	675	10,2
500	750	11,9
560	840	15,2
600	900	17,0
630	945	18,8
710	1065	22,7
800	1200	26,9
900	1350	39,3
1000	1500	47,7
1120	1680	63,0
1250	1875	78,5

...

Ordering example

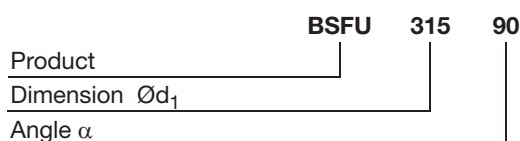



Dimensions

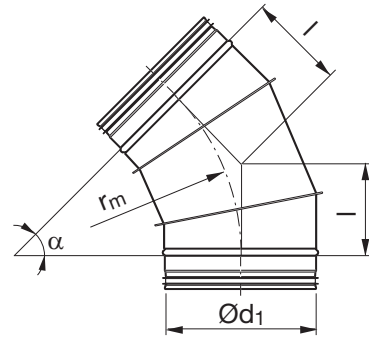

$$r_m = 1,5 \cdot d_1$$

Description

Segmented and lockseamed bend.

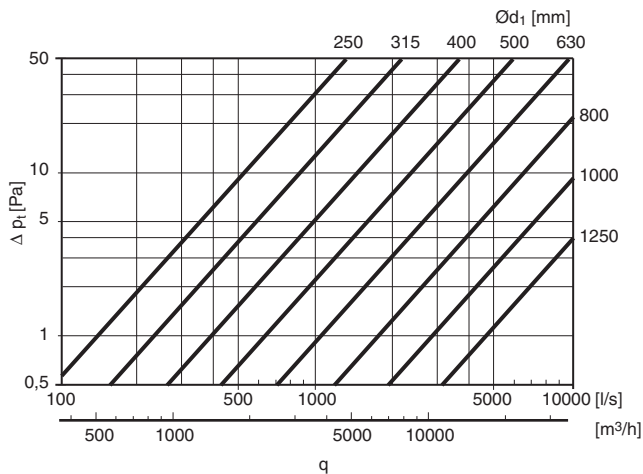

$\text{O} d_1$ nom	l mm	m kg
250	155	1,60
280	174	1,81
300	186	2,00
315	196	2,26
355	221	2,60
400	249	4,50
450	280	5,53
500	311	6,60
560	348	7,95
600	373	8,80
630	391	9,50
710	441	11,1
800	497	13,1
900	559	18,9
1000	621	23,9
1120	696	29,6
1250	777	36,1

Ordering example

Product **BSFU**
 Dimension $\text{O} d_1$ **315**
 Angle α **45**

Bend – Casting-in programme

BKMU 90°



Dimensions

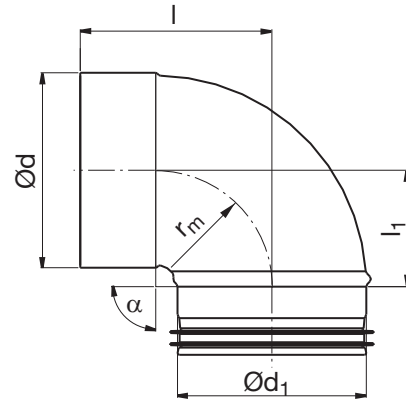

$$r_m = 0,6 \cdot d_1$$

Ød ₁ nom	Ød nom	l mm	l ₁ mm	m kg
80	80	123	80	0,13
100	100	105	62	0,21
125	125	120	79	0,31
160	160	136	94	0,63

Description

Pressed and seam welded bend with short installation length and female end.

Has Click function at the Safe end – has an open turned-over end.

Has normally not any Click function at the female end – hasn't any notches.

Ø 125–160 can upon order be delivered with click function at the female end as well – i.e. with notches.

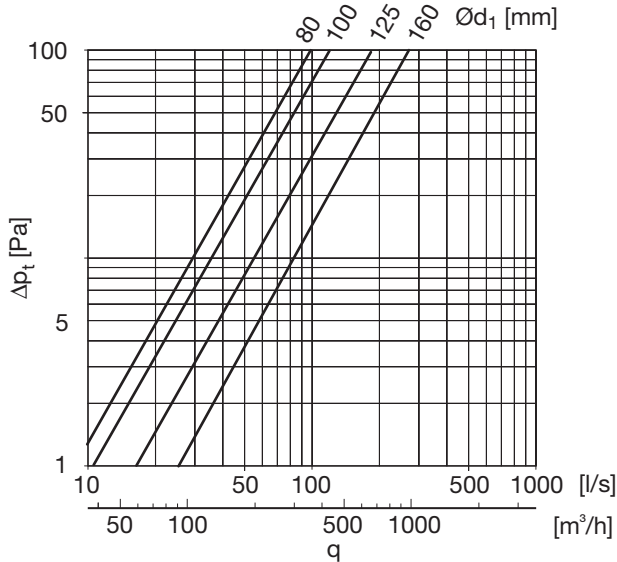

Ordering example

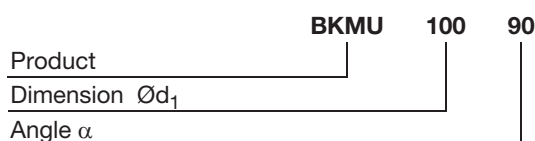

Bend, short, segmented, female end

BKFMU 90°



Dimensions

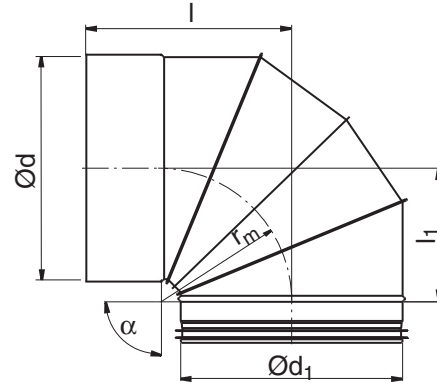

$$r_m \approx 0,6 \cdot d_1$$

Description

Segmented and lockseamed bend with short installation length and female end.

Has Click function at the Safe end – has an open turned-over end.

Has normally not any Click function at the female end – hasn't any notches.

Ø 200–315 can upon order be delivered with click function at the female end as well – i.e. with notches.

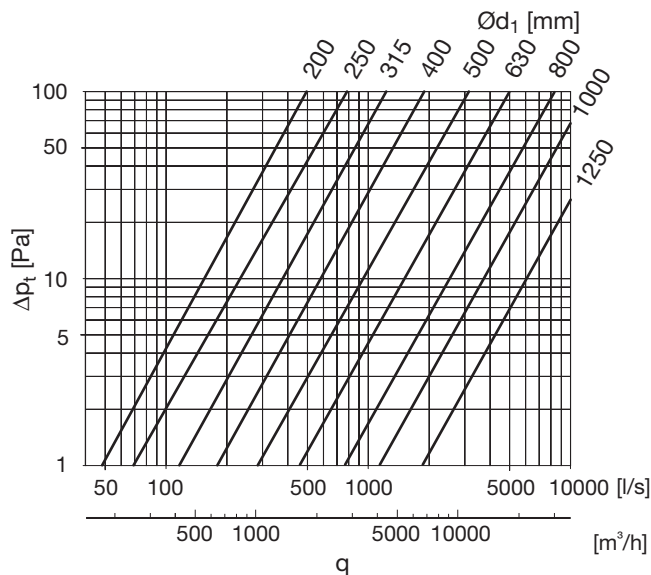

Ød ₁ nom	Ød nom	l mm	l ₁ mm	m kg
200	200	199	158	1,17
250	250	240	180	1,59
315	315	280	220	2,26
400	400	335	255	3,46
500	500	395	315	6,33
630	630	475	397	9,51
710	710	525	425	16,0
800	800	570	470	20,0
1000	1000	690	570	32,0
1120	1120	750	630	41,0
1250	1250	815	695	52,0

Ordering example





Dimensions

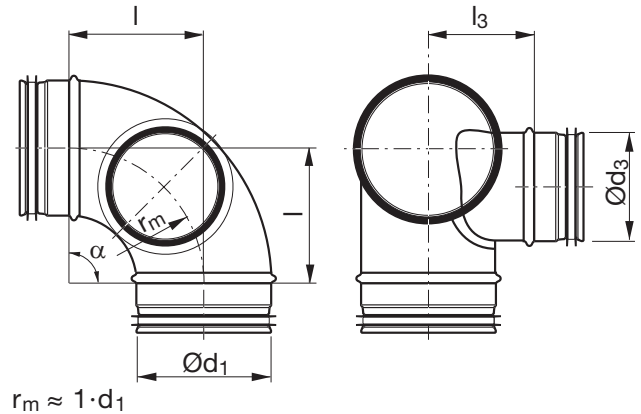

Description

Pressed and seam welded bend with separate branch for cleaning. The stud is fitted with a Safe take-off and fits an inspection cap. The design gives a lower pressure drop than the equivalent design using a T-piece. The stud can also be used as the connection for an SR duct.

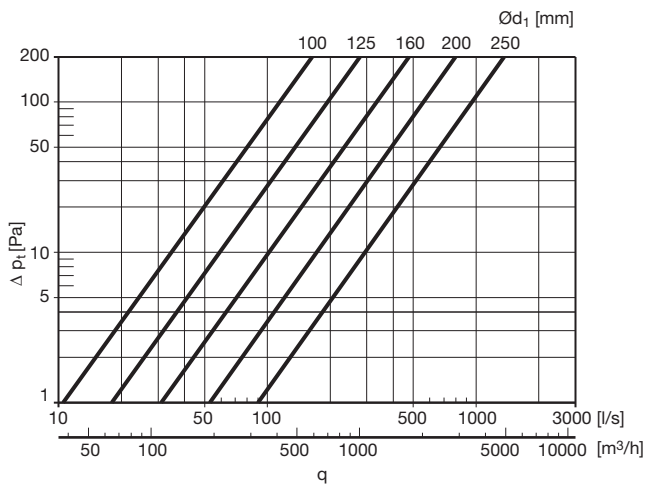

The graph applies to a cleaning bend with cleaning cap. Pressure drop is independent of take-off dimension ($\text{O}d_3 \leq \text{O}d_1$).

$\text{O}d_1$ nom	$\text{O}d_3$ nom	l mm	l ₃ mm	m kg
100	100	100	75	0,41
112	100	120	85	0,50
125	100	125	90	0,59
125	125	125	90	0,66
140	125	135	100	0,75
150	125	150	105	0,78
160	125	160	110	0,97
160	160	160	110	0,97
180	160	180	120	1,18
200	160	200	130	1,24
200	200	200	130	1,28
224	200	225	140	1,57
250	200	250	155	1,93
250	250	250	150	2,01

Ordering example

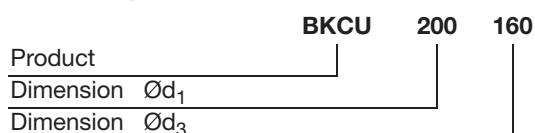



Description

Segmented and lockseamed bend with separate branch for cleaning. The stud is fitted with a Safe take-off and fits an inspection cap. The design gives a lower pressure drop than the equivalent design using a T-piece. The stud can also be used as the connection for an SR duct.

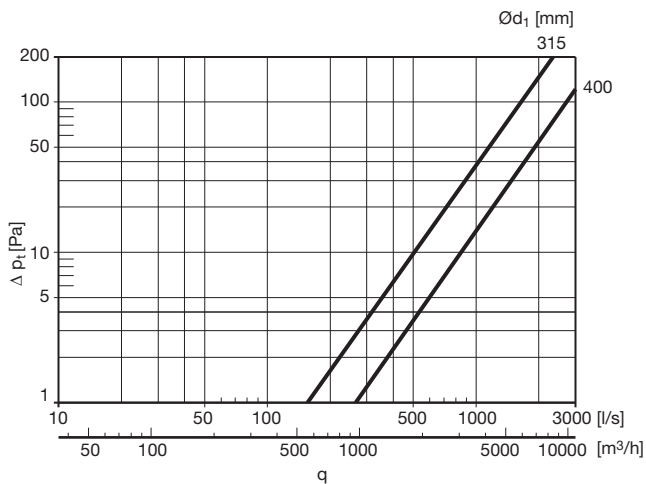

The graph applies to a cleaning bend with cleaning cap. Pressure drop is independent of take-off dimension ($\text{Ø}d_3 \leq \text{Ø}d_1$).

Ordering example

Product	BFKCU	315	250
Dimension $\text{Ø}d_1$		315	
Dimension $\text{Ø}d_3$			250

Dimensions

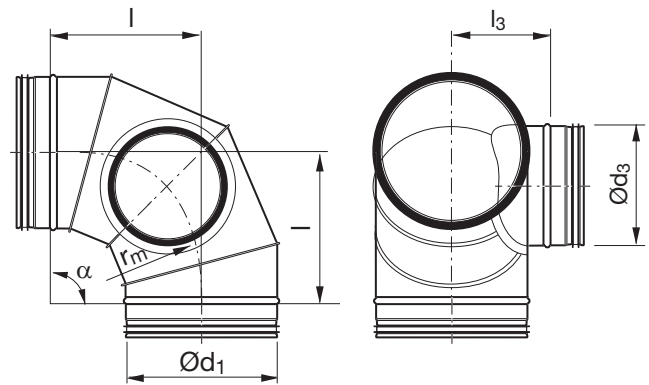

$$r_m \approx 1 \cdot d_1$$

$\text{Ø}d_1$ nom	$\text{Ø}d_3$ nom	l mm	l ₃ mm	m kg
300	250	300	177	4,10
315	250	315	185	4,60
315	315	315	185	4,60
400	315	400	227	7,53
400	400	400	227	7,25

1

2

3

4

5

6

7

8

9

10

11

12

13

14

15

16

17

18



Dimensions

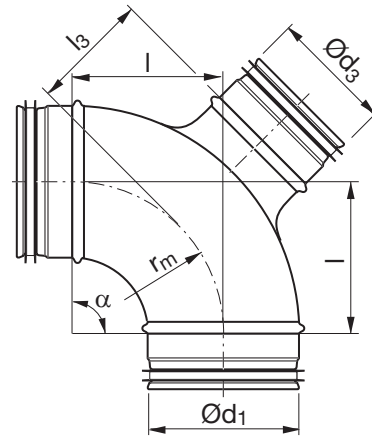

$$r_m \approx 1 \cdot d_1$$

Description

Pressed and seam welded bend with separate branch for cleaning. The stud is fitted with a Safe take-off and fits an inspection cap.

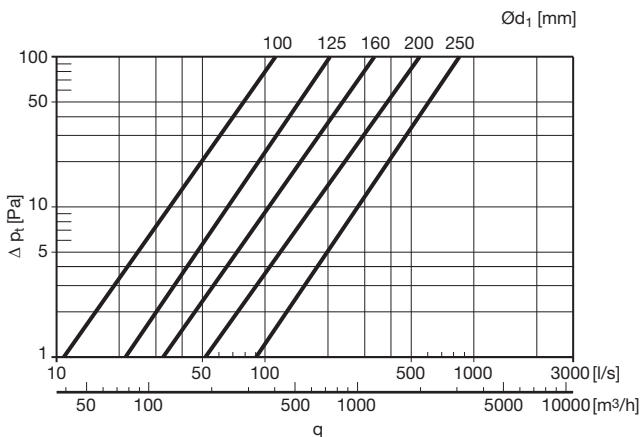

The graph applies to a cleaning bend with cleaning cap EPFH and with the same dimension of take-off and main duct ($\text{Ø}d_3 = \text{Ø}d_1$).

The pressure drop is about 30% lower for cleaning cap KCU and $\text{Ø}d_3 = \text{Ø}d_1$.

The pressure drop is about 30% lower for cleaning cap EPFH and one step smaller take-off dimension ($\text{Ø}d_3 < \text{Ø}d_1$).

The pressure drop is about 50% lower for cleaning cap KCU and one step smaller take-off dimension ($\text{Ø}d_3 < \text{Ø}d_1$).

$\text{Ø}d_1$ nom	$\text{Ø}d_3$ nom	l mm	l ₃ mm	m kg
100	100	100	75	0,42
112	100	120	78	0,51
125	100	125	78	0,58
125	125	125	83	0,58
140	125	135	90	0,75
150	125	150	90	0,77
160	125	160	100	0,97
160	160	160	105	0,96
180	160	180	108	1,20
200	160	200	125	1,24
200	200	200	125	1,29
224	200	225	128	1,67
250	200	250	150	2,02
250	250	250	150	2,12

Ordering example

Product	BBKCU	200	160
Dimension $\text{Ø}d_1$			
Dimension $\text{Ø}d_3$			

Cleaning bend

BFBKCU 90°



Dimensions

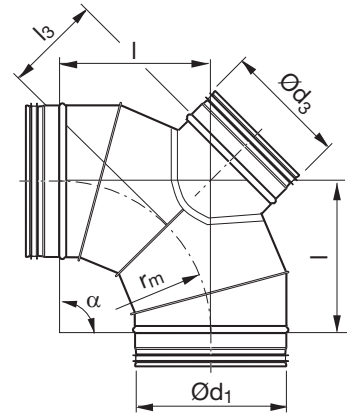

$$r_m \approx 1 \cdot d_1$$

Description

Segmented and lockseamed bend with separate branch for cleaning. The stud is fitted with a Safe take-off and fits an inspection cap.

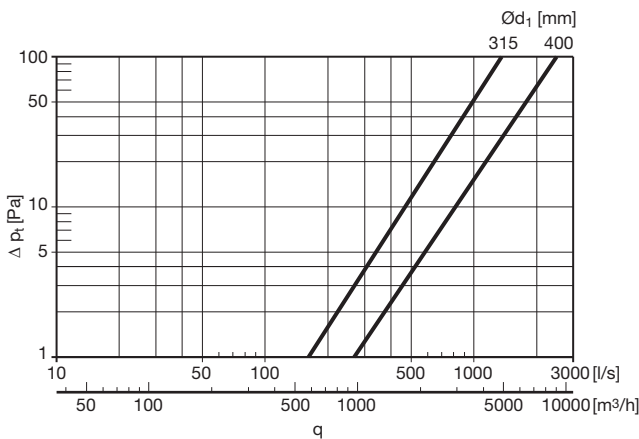

The graph applies to a cleaning bend with cleaning cap EPFH and with the same dimension of take-off and main duct ($\varnothing d_3 = \varnothing d_1$).

The pressure drop is about 30% lower for cleaning cap KCU and $\varnothing d_3 = \varnothing d_1$.

The pressure drop is about 30% lower for cleaning cap EPFH and one step smaller take-off dimension ($\varnothing d_3 < \varnothing d_1$).

The pressure drop is about 50% lower for cleaning cap KCU and one step smaller take-off dimension ($\varnothing d_3 < \varnothing d_1$).

$\varnothing d_1$ nom	$\varnothing d_3$ nom	l mm	l ₃ mm	m kg
300	250	300	177	4,00
315	250	315	185	4,50
315	315	315	185	4,50
400	315	400	227	7,30
400	400	400	227	7,30

Ordering example





Dimensions

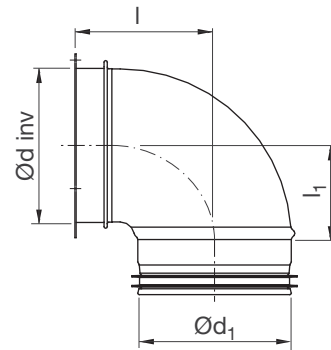

Description

Short installation length with female end and nail flange with pre-punched holes.

Ød_1 nom	Ød nom	l mm	l ₁ mm	m kg
80	80	101	80	0,26
100	100	93	62	0,24
125	125	106	79	0,32
160	160	130	94	0,43

Ordering example

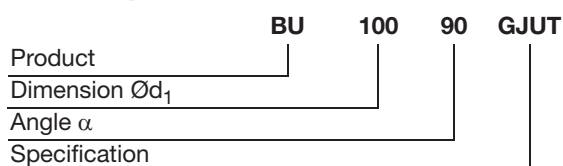



Description

Short installation length with air valve socket and nail flange with pre-punched holes. Fits air valve KVB etc.

Dimensions

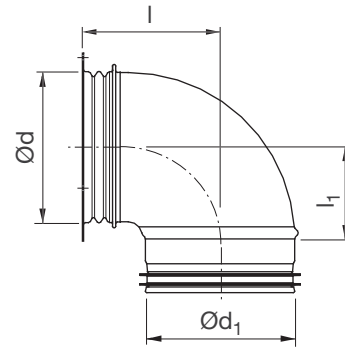

Ød ₁ nom	Ød nom	l mm	l ₁ mm	m kg
100	92	93	62	0,23
125	117	106	79	0,31
160	152	131	94	0,39

Ordering example

	BSIU	100	90	GJUT
Product				
Dimension Ød ₁				
Angle α				
Specification				





Dimensions

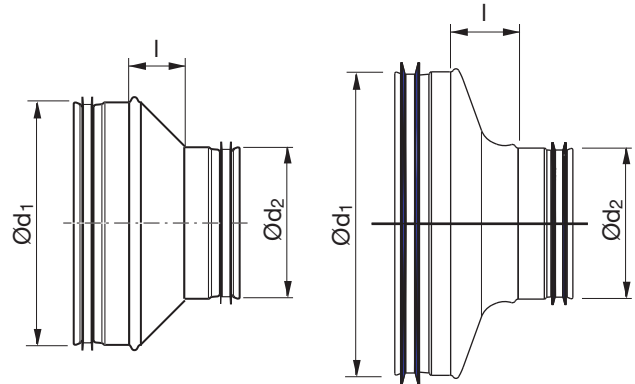

Description

Pressed, concentric reducer to meet demands for short installation length with low pressure drop and low internal noise generation.

Pressure drop, see graphs on page 90.

Ød ₁ nom	Ød ₂ nom	l mm	m kg
80	63	18	0,12
100	63	30	0,17
100 *	80	26	0,18
125 *	80	36	0,16
125 *	100	27	0,21
150	100	36	0,17
150 *	125	31	0,15
160	80	55	0,31
160 *	100	46	0,17
160 *	125	35	0,22
160	150	22	0,26
180	100	55	0,24
180	125	40	0,37
180	150	27	0,29
180	160	20	0,26
200 *	100	46	0,22
200 *	125	55	0,30
200	150	37	0,37
200 *	160	39	0,29
200	180	26	0,35
224	150	48	0,53
224	160	44	0,53
224	180	34	0,48
224	200	24	0,45
250	125	70	0,62
250	150	62	0,60
250 *	160	60	0,46
250	180	47	0,59
250 *	200	42	0,46
250	224	29	0,57
300 *	200	59	0,64
300	250	34	0,71
315	160	91	0,86

Ordering example

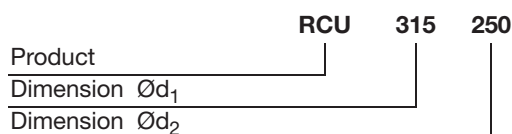

Reducer

$\varnothing d_1$ nom	$\varnothing d_2$ nom	l mm	m kg
315 *	200	74	0,72
315 *	250	50	0,65
355	250	69	1,08
355	315	33	0,99
400	200	118	1,37
400	250	94	1,38
400	315	54	1,29
500 **	250	128	2,30
500	315	95	1,90
500	400	68	1,76
630 **	315	160	3,37
630 **	400	118	3,17
630 **	500	68	2,89

* With stream-lined transition

** Hand made

1

2

3

4

5

6

7

8

9

10

11

12

13

14

15

16

17

18



Dimensions

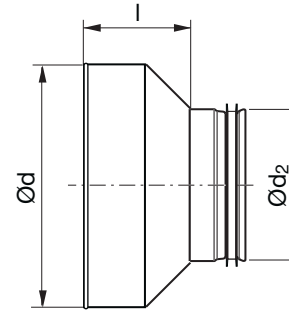

Description

Pressed, concentric reducer with female coupling, with a 45° angle to meet demands for short installation length with low pressure drop and low internal noise generation. Ød fits outside another fitting.

Pressure drop, see graphs on page 90.

Has Click function at the Safe end – has an open turned-over end.

Has normally not any Click function at the female end – hasn't any notches.

Ø 80–315 can upon order be delivered with click function at the female end as well – i.e. with notches.

Ød nom	Ød ₂ nom	l mm	m kg
80	63	57	0,11
100	63	70	0,14
100 * ¹	80	61	0,16
125 * ¹	80	73	0,16
125 * ¹	100	64	0,14
150	100	78	0,16
150 ¹	125	66	0,17
160 *	80	92	0,24
160 * ¹	100	83	0,16
160 * ¹	125	71	0,20
160	150	59	0,25
180	100	98	0,24
180	125	85	0,31
180	150	68	0,24
180	160	66	0,27
200 * ¹	100	84	0,23
200 * ¹	125	90	0,27
200	150	75	0,34
200 * ¹	160	73	0,26
200	180	63	0,32
224	150	92	0,45
224	160	87	0,49
224	180	76	0,46
224	200	66	0,45
250 *	125	133	0,57
250	150	122	0,56
250 * ¹	160	117	0,40
250	180	107	0,55
250 * ¹	200	103	0,42
250	224	89	0,53
300	200	119	0,68
300	250	94	0,66
315 *	160	153	0,82

Ordering example

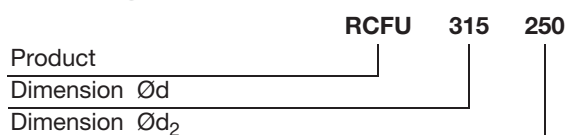

Ød nom	Ød ₂ nom	l mm	m kg
315 *1	200	134	0,77
315 *1	250	108	0,65
355	250	136	1,04
355	315	97	0,89
400 *	200	196	1,31
400 *	250	174	1,37
400 *	315	133	1,20
500 **	250	208	2,12
500 **	315	185	2,09
500 **	400	150	1,95
630 **	315	240	2,76
630 **	400	198	2,72
630 **	500	148	2,69

* With turned-over edge

** Hand made

1 With stream-lined transition

1

2

3

4

5

6

7

8

9

10

11

12

13

14

15

16

17

18

Technical data

1 dimension step

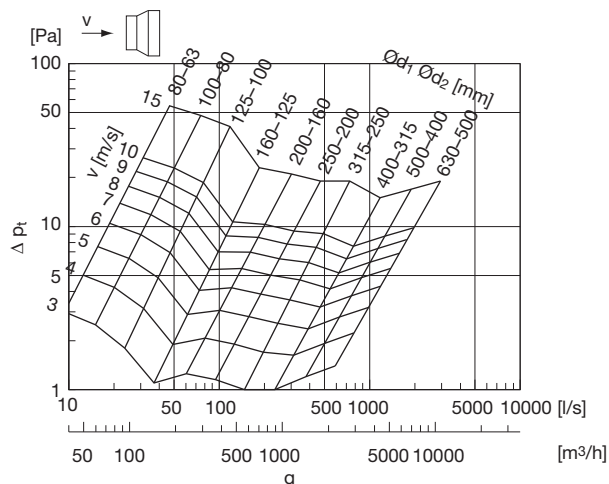
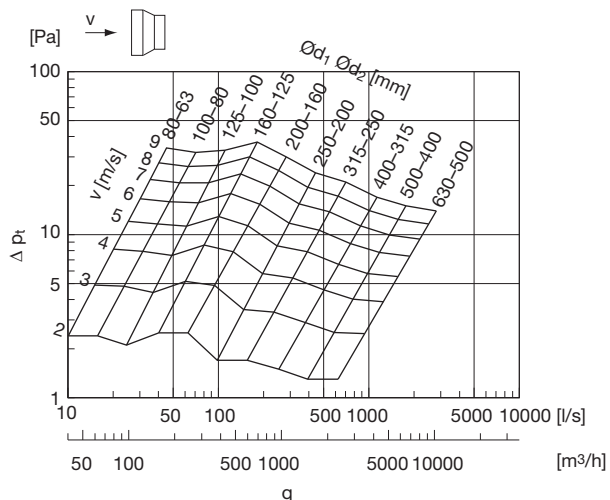

2 dimension steps

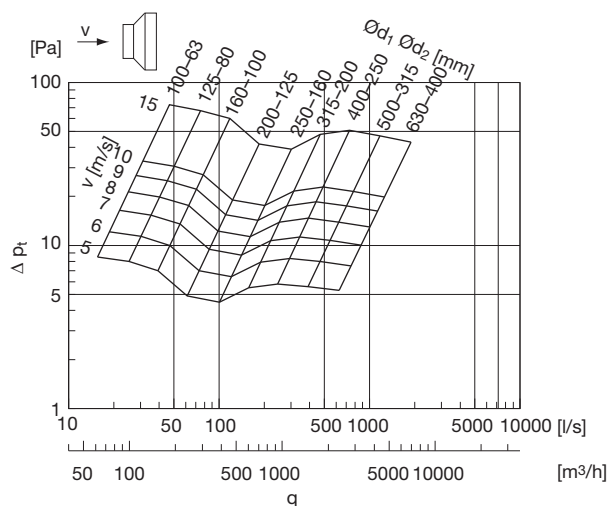
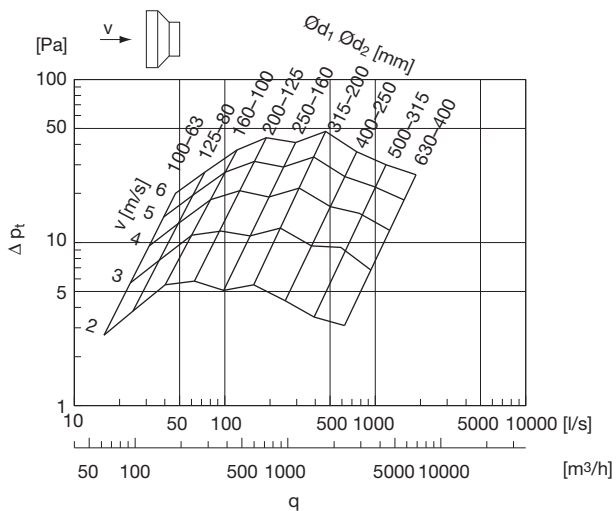

3 dimension steps

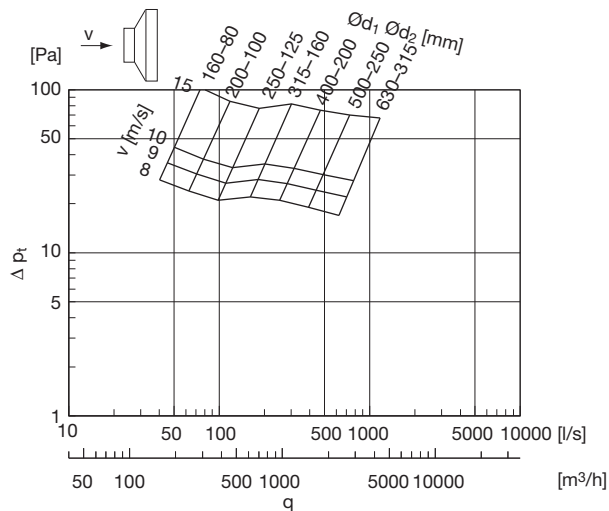
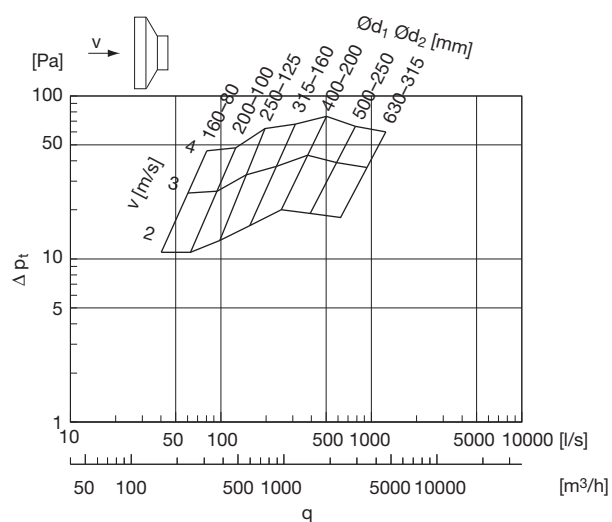



Description

Short, eccentric reducer to achieve extremely short installation length.

Dimensions

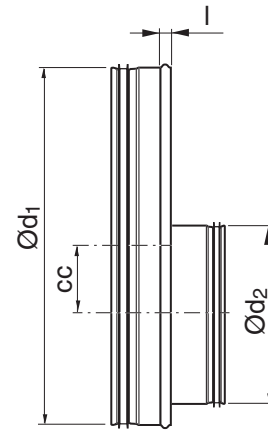

Ød ₁ nom	Ød ₂ nom	cc mm	l mm	m kg
400	200	90	12	1,42
400	224	78	12	1,48
400	250	65	12	1,54
400	280	50	12	1,53
400	300	40	12	1,52
400	315	33	12	1,51
400	355	13	12	1,13
450	250	90	4	1,76
450	280	75	4	1,75
450	300	65	4	1,74
450	315	58	4	1,73
450	355	38	4	1,64
450	400	15	4	1,31
500	250	115	12	1,98
500	280	100	12	1,97
500	300	90	12	1,96
500	315	83	12	1,95
500	355	63	12	1,87
500	400	40	12	1,92
500	450	15	12	1,46
560	315	113	4	2,29
560	355	93	4	2,21
560	400	70	4	2,26
560	450	45	4	1,80
560	500	20	4	1,70
600	315	133	4	2,63
600	355	113	4	2,54
600	400	90	4	2,60
600	450	65	4	2,14
600	500	40	4	2,56
600	560	10	4	1,87
630	315	148	4	2,85
630	355	128	4	2,77

Ordering example

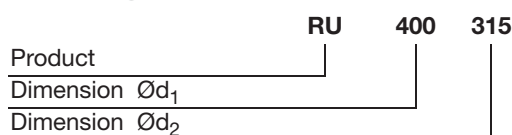

1

2

3

4

5

6

7

8

9

10

11

12

13

14

15

16

17

18

Ød ₁ nom	Ød ₂ nom	cc mm	l mm	m kg
630	400	105	4	2,82
630	450	80	4	2,36
630	500	55	4	2,78
630	560	25	4	2,09
630	600	5	4	1,90
710	400	145	4	3,43
710	450	120	4	2,97
710	500	95	4	3,39
710	560	65	4	2,70
710	600	45	4	2,51
710	630	30	4	2,48
800	400	190	4	4,06
800	450	165	4	3,60
800	500	140	4	4,02
800	560	110	4	3,33
800	600	90	4	3,14
800	630	75	4	3,75
800	710	35	4	3,06
900	500	190	4	5,30
900	560	160	4	4,58
900	600	140	4	4,36
900	630	125	4	4,95
900	710	85	4	4,20
900	800	40	4	4,01
1000	500	240	4	6,52
1000	560	210	4	5,80
1000	600	190	4	5,58
1000	630	175	4	6,17
1000	710	135	4	5,42
1000	800	90	4	5,23
1000	900	40	4	4,94
1120	630	235	4	7,59
1120	710	195	4	6,48
1120	800	150	4	6,64
1120	900	100	4	6,36
1120	1000	50	4	5,46
1250	630	300	4	9,69
1250	710	260	4	8,94
1250	800	215	4	8,74
1250	900	165	4	8,46
1250	1000	115	4	7,56
1250	1120	55	4	7,53



Description

Short, eccentric reducer with female end to achieve extremely short installation length.

Ød fits outside another fitting.

Dimensions

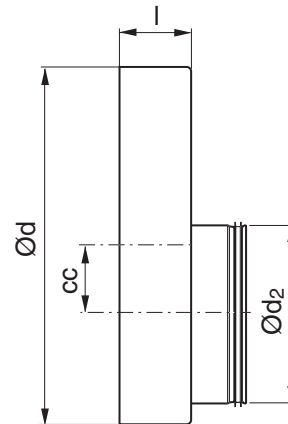

Ød nom	Ød ₂ nom	cc mm	l mm	m kg
400 *	200	90	80	1,33
400	224	78	80	1,39
400 *	250	65	80	1,44
400	280	50	80	1,43
400	300	40	80	1,43
400 *	315	33	80	1,42
400	355	13	80	0,99
450	250	90	80	1,76
450	280	75	80	1,75
450	300	65	80	1,74
450	315	58	80	1,73
450	355	38	80	1,69
450	400	15	80	1,31
500	250	115	80	2,09
500	280	100	80	2,08
500	300	95	80	2,07
500	315	83	80	2,06
500	355	63	80	1,98
500	400	40	80	2,03
500	450	15	80	1,57
560	315	113	80	2,39
560	355	93	80	2,32
560	400	70	80	2,36
560	450	45	80	1,90
560	500	20	80	1,80
600	315	133	80	2,62
600	355	113	80	2,54
600	400	90	80	2,59
600	450	65	80	2,53
600	500	40	80	2,54
600	560	10	80	1,86
630	315	148	80	2,79
630	355	128	80	2,71

Ordering example

Product	RFU	630	315
Dimension Ød			
Dimension Ød ₂			

Ød nom	Ød₂ nom	cc mm	l mm	m kg
630	400	105	80	2,76
630	450	80	80	2,30
630	500	55	80	2,72
630	560	25	80	2,03
630	600	5	80	1,84
710	400	145	100	3,72
710	450	120	100	2,76
710	500	95	100	3,18
710	560	65	100	2,49
710	600	45	100	2,30
710	630	30	100	2,44
800	400	190	100	3,76
800	450	165	100	3,30
800	500	140	100	3,72
800	560	110	100	3,03
800	600	90	100	2,84
800	630	75	100	3,44
800	710	35	100	2,76
900	500	190	100	6,14
900	560	160	100	5,42
900	600	140	100	5,20
900	630	125	100	5,74
900	710	85	100	5,04
900	800	40	100	4,84
1000	500	240	100	7,34
1000	560	210	100	6,42
1000	600	190	100	6,40
1000	630	175	100	6,99
1000	710	135	100	6,24
1000	800	90	100	6,04
1000	900	40	100	5,76
1120	630	235	120	9,09
1120	710	195	120	8,34
1120	800	150	120	8,14
1120	900	100	120	7,86
1120	1000	50	120	6,96
1250	630	300	120	11,0
1250	710	260	120	10,3
1250	800	215	120	10,0
1250	900	165	120	9,76
1250	1000	115	120	8,86
1250	1120	55	120	8,83

* With turned-over edge



Description

Long, tangential, hand made reducer with a female end and with approx. 35° angle.

Dimensions are otherwise adapted to DIN 24147 section 4.

Has Click function at the Safe end – has an open turned-over end.

Has normally not any Click function at the female end – hasn't any notches.

Ø 80–315 can upon order be delivered with click function at the female end as well – i.e. with notches.

Dimensions

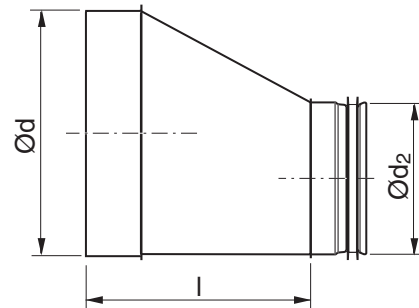

Ød nom	Ød ₂ nom	l mm	m kg
80	63	98	0,14
100	63	126	0,20
100	80	103	0,18
112	63	142	0,23
112	80	119	0,22
112	100	92	0,20
125	63	159	0,28
125	80	137	0,26
125	100	109	0,24
125	112	93	0,23
140	63	181	0,33
140	80	157	0,32
140	100	130	0,30
140	112	114	0,28
140	125	96	0,27
150	63	195	0,37
150	80	171	0,36
150	100	144	0,34
150	112	127	0,32
150	125	109	0,30
150	140	99	0,28
160	63	207	0,43
160	80	185	0,42
160	100	157	0,40
160	112	141	0,38
160	125	123	0,36
160	140	102	0,34
160	150	99	0,32
180	80	212	0,51
180	100	185	0,49
180	112	168	0,47
180	125	151	0,46
180	140	130	0,43

Ordering example

Product	RFLU	250	160
Dimension Ød			
Dimension Ød ₂			

Ød nom	Ød ₂ nom	l mm	m kg
180	150	116	0,41
180	160	103	0,41
200	80	240	0,61
200	100	213	0,59
200	112	196	0,57
200	125	178	0,55
200	140	157	0,53
200	150	144	0,51
200	160	130	0,50
200	180	103	0,46
224	100	215	0,72
224	112	229	0,70
224	125	211	0,68
224	140	190	0,65
224	150	177	0,64
224	160	163	0,63
224	180	135	0,58
224	200	107	0,53
250	100	301	0,94
250	112	285	0,92
250	125	267	0,90
250	140	246	0,89
250	150	232	0,87
250	160	219	0,87
250	180	191	0,80
250	200	164	0,75
250	224	131	0,67
280	125	308	1,10
280	140	287	1,08
280	150	274	1,06
280	160	260	1,05
280	180	232	1,00
280	200	205	0,95
280	224	172	0,87
280	250	136	0,84
300	125	335	1,25
300	140	315	1,22
300	150	301	1,20
300	160	287	1,20
300	180	260	1,15
300	200	262	1,09
300	224	200	1,02
300	250	164	0,98
300	280	123	0,86
315	125	356	1,36
315	140	335	1,33
315	150	322	1,32
315	160	308	1,31

Ød nom	Ød ₂ nom	l mm	m kg
315	180	281	1,26
315	200	253	1,21
315	224	220	1,13
315	250	184	1,09
315	280	143	0,97
315	300	116	0,88
355	160	363	1,84
355	180	335	1,77
355	200	308	1,71
355	224	275	1,61
355	250	239	1,56
355	280	198	1,41
355	300	171	1,30
355	315	150	1,21
400	160	450	2,44
400	180	422	2,38
400	200	395	2,31
400	224	362	2,23
400	250	326	2,20
400	280	285	2,01
400	300	257	1,90
400	315	237	1,86
400	355	182	1,55
450	200	463	2,99
450	224	431	2,90
450	250	395	2,85
450	280	354	2,70
450	300	326	2,59
450	315	306	2,50
450	355	251	2,24
450	400	194	2,64
500	200	532	3,66
500	224	499	3,56
500	250	463	3,51
500	280	422	3,36
500	300	395	3,25
500	315	374	3,16
500	355	319	2,89
500	400	262	2,69
500	450	194	2,37
560	250	546	4,47
560	280	505	4,32
560	300	477	4,21
560	315	456	4,11
560	355	402	3,85
560	400	345	3,66
560	450	276	2,70
560	500	207	2,86

Ød nom	Ød ₂ nom	l mm	m kg
600	250	601	5,10
600	280	560	4,96
600	300	532	4,84
600	315	512	4,76
600	355	457	4,49
600	400	400	4,29
600	450	331	3,96
600	500	262	3,49
600	560	180	2,94
630	250	642	5,60
630	280	601	5,46
630	300	573	5,34
630	315	553	5,25
630	355	498	4,99
630	400	441	4,79
630	450	372	4,46
630	500	304	4,00
630	560	221	3,43
630	600	166	2,97
710	355	633	7,11
710	400	576	6,92
710	450	507	6,60
710	500	438	6,12
710	560	356	5,57
710	600	301	5,10
710	630	260	4,72
800	400	699	8,81
800	450	631	8,49
800	500	562	8,02
800	560	480	7,46
800	600	425	6,99
800	630	384	6,62
800	710	279	6,21
900	450	768	10,8
900	500	699	10,3
900	560	617	9,78
900	600	562	9,31
900	630	521	8,94
900	710	416	8,53
900	800	292	7,18
1000	560	774	12,5
1000	600	719	12,0
1000	630	678	11,7
1000	710	573	11,2
1000	800	450	9,91
1000	900	312	8,17
1120	560	939	16,4
1120	600	884	15,9

Ød nom	Ød ₂ nom	l mm	m kg
1120	630	843	15,5
1120	710	738	15,1
1120	800	615	13,8
1120	900	477	12,1
1120	1000	656	16,2
1250	600	340	10,3
1250	630	1063	20,1
1250	710	1022	19,7
1250	800	917	19,3
1250	900	793	17,9
1250	1000	518	14,4
1250	1120	354	12,2

1

2

3

4

5

6

7

8

9

10

11

12

13

14

15

16

17

18



Dimensions

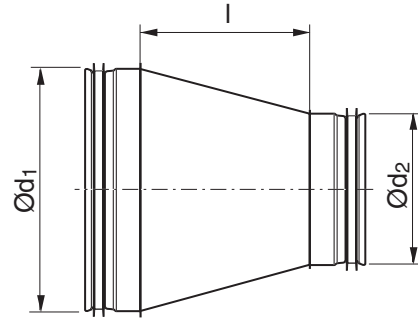

Description

Long, concentric, hand made reducer with approx. 18° angle.

Ød ₁ nom	Ød ₂ nom	l mm	m kg
112	63	97	0,23
112	80	74	0,22
112	100	47	0,20
125	63	115	0,28
125	112	48	0,23
140	63	136	0,33
140	80	112	0,32
140	100	85	0,30
140	112	69	0,28
140	125	51	0,27
150	63	150	0,37
150	80	126	0,36
150	112	82	0,32
150	140	44	0,28
160	63	163	0,43
160	112	96	0,38
160	140	57	0,34
180	80	167	0,51
180	112	123	0,47
180	140	85	0,43
200	80	195	0,61
200	112	151	0,57
200	140	112	0,53
224	100	200	0,72
224	112	184	0,70
224	125	166	0,68
224	140	145	0,65
250	100	236	0,94
250	112	220	0,92
250	140	181	0,89
280	125	243	1,10
280	140	222	1,08
280	150	209	1,06

Ordering example

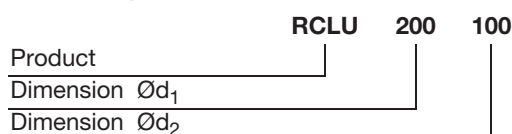

Ød ₁ nom	Ød ₂ nom	l mm	m kg
280	160	195	1,05
280	180	167	1,00
280	200	140	0,95
280	224	107	0,87
280	250	71	0,84
300	125	270	1,25
300	140	250	1,22
300	150	236	1,20
300	160	222	1,20
300	180	195	1,15
300	224	135	1,02
300	280	58	0,86
315	125	291	1,36
315	140	270	1,33
315	150	257	1,32
315	180	216	1,26
315	224	155	1,13
315	280	78	0,97
315	300	51	0,88
355	160	298	1,84
355	180	270	1,77
355	200	243	1,71
355	224	210	1,61
355	280	133	1,41
355	300	106	1,30
400	160	365	2,44
400	180	337	2,38
400	224	277	2,23
400	280	200	2,01
400	300	172	1,90
400	355	97	1,55
450	200	378	2,99
450	224	346	2,90
450	250	310	2,85
450	280	269	2,70
450	300	241	2,59
450	315	221	2,50
450	355	166	2,24
450	400	109	2,64
500	200	447	3,66
500	224	414	3,56
500	280	337	3,36
500	300	310	3,25
500	355	234	2,89
500	450	109	2,37
560	250	461	4,47
560	280	420	4,32
560	300	392	4,21

Ød ₁ nom	Ød ₂ nom	l mm	m kg
560	315	371	4,11
560	355	317	3,85
560	400	260	3,66
560	450	191	2,70
560	500	122	2,86
600	250	516	5,10
600	280	475	4,96
600	300	447	4,84
600	315	427	4,76
600	355	372	4,49
600	400	315	4,29
600	450	246	3,96
600	500	177	3,49
600	560	95	2,94
630	250	557	5,60
630	280	516	5,46
630	300	488	5,34
630	355	413	4,99
630	450	287	4,46
630	560	136	3,43
630	600	81	2,97
710	355	528	7,11
710	400	471	6,92
710	450	402	6,60
710	500	333	6,12
710	560	251	5,57
710	600	196	5,10
710	630	155	4,72
800	400	594	8,81
800	450	526	8,49
800	500	457	8,02
800	560	375	7,46
800	600	320	6,99
800	630	279	6,62
800	710	174	6,21
900	450	663	10,8
900	500	594	10,3
900	560	512	9,78
900	600	457	9,31
900	630	416	8,94
900	710	311	8,53
900	800	187	7,18
1000	500	732	13,1
1000	560	649	12,5
1000	600	594	12,0
1000	630	553	11,7
1000	710	448	11,2
1000	800	325	9,91

- 1
- 2
- 3**
- 4
- 5
- 6
- 7
- 8
- 9
- 10
- 11
- 12
- 13
- 14
- 15
- 16
- 17
- 18

- 1
- 2
- 3
- 4
- 5
- 6
- 7
- 8
- 9
- 10
- 11
- 12
- 13
- 14
- 15
- 16
- 17
- 18

$\text{\O}d_1$ nom	$\text{\O}d_2$ nom	l mm	m kg
1000	900	187	8,17
1120	560	814	16,4
1120	600	759	15,9
1120	630	718	15,5
1120	710	613	15,1
1120	800	490	13,8
1120	900	352	12,1
1120	1000	215	10,3
1250	600	938	20,1
1250	630	897	19,7
1250	710	792	19,3
1250	800	668	17,9
1250	900	531	16,2
1250	1000	393	14,4
1250	1120	229	12,2

Technical data

1 dimension step

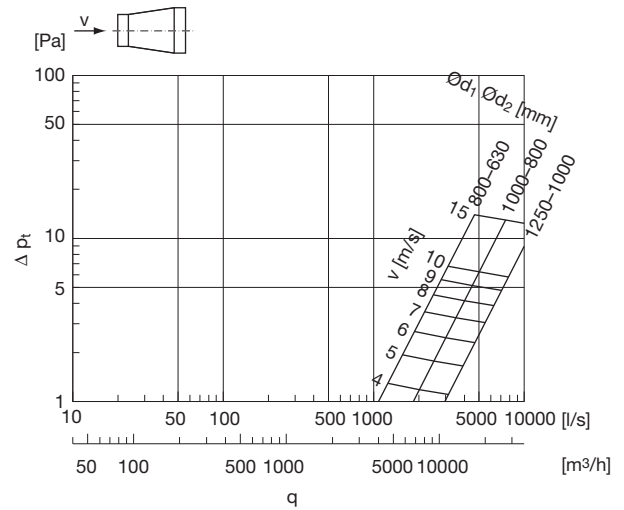
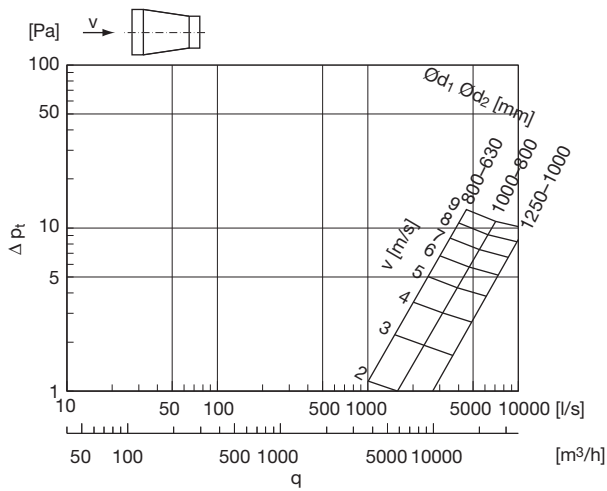

2 dimension steps

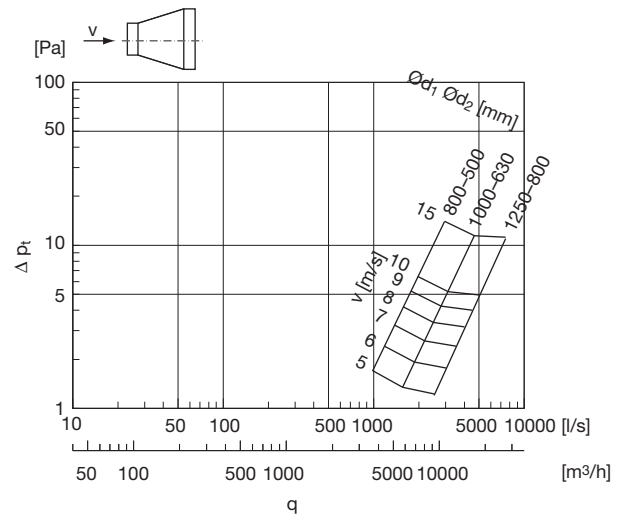
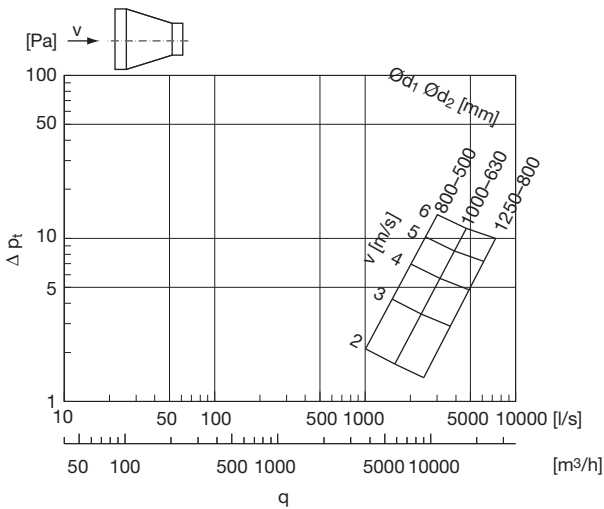

3 dimension steps

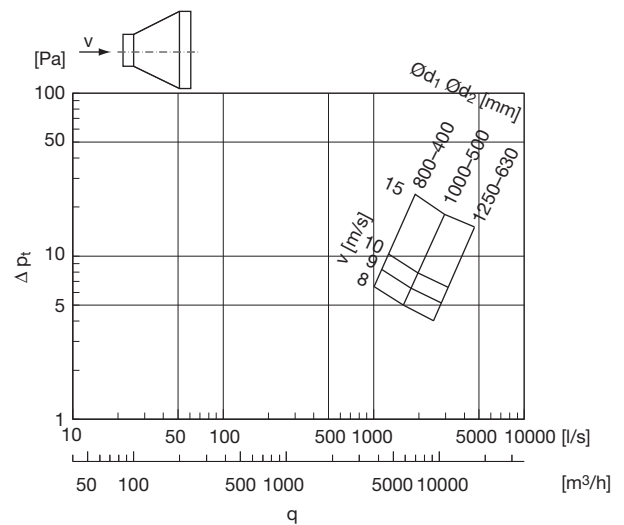
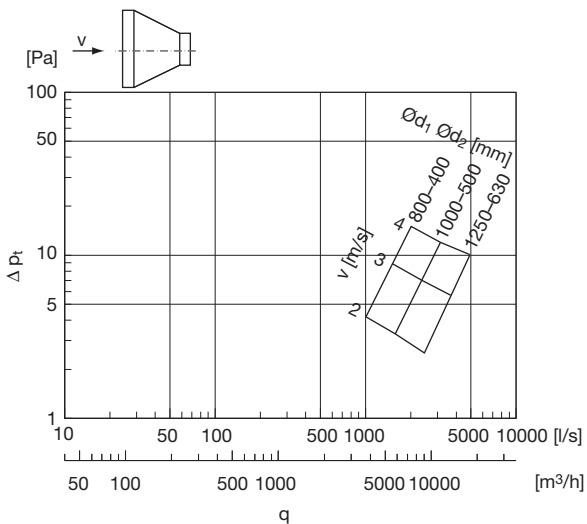

- 1
- 2
- 3
- 4
- 5
- 6
- 7
- 8
- 9
- 10
- 11
- 12
- 13
- 14
- 15
- 16
- 17
- 18



Dimensions

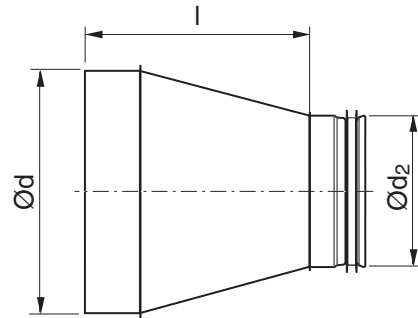

Description

Long, concentric, hand made reducer with a female end and with approx. 18° angle.

Has Click function at the Safe end – has an open turned-over end.

Has normally not any Click function at the female end – hasn't any notches.

Ø 80–315 can upon order be delivered with click function at the female end as well – i.e. with notches.

Ød nom	Ød ₂ nom	l mm	m kg
80	63	98	0,14
100	63	126	0,20
100	80	103	0,18
112	63	142	0,23
112	80	119	0,22
112	100	92	0,20
125	63	159	0,28
125	100	109	0,24
125	112	93	0,23
140	63	137	0,26
140	80	181	0,33
140	112	130	0,30
140	125	114	0,28
140	140	96	0,27
150	63	157	0,32
150	80	195	0,37
150	100	144	0,34
150	112	127	0,32
150	125	109	0,30
150	140	99	0,28
160	63	171	0,36
160	80	207	0,43
160	100	157	0,40
160	112	141	0,38
160	125	123	0,36
160	140	102	0,34
160	150	99	0,32
180	80	185	0,42
180	100	185	0,49
180	112	168	0,47
180	125	151	0,46
180	140	130	0,43
180	150	116	0,41

Ordering example

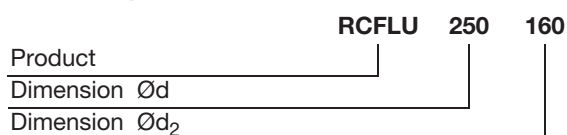

Ød nom	Ød ₂ nom	l mm	m kg
180	160	103	0,41
200	80	212	0,51
200	100	213	0,59
200	112	196	0,57
200	125	178	0,55
200	140	157	0,53
200	150	144	0,51
200	160	130	0,50
200	180	103	0,46
224	100	215	0,72
224	112	229	0,70
224	125	211	0,68
224	140	190	0,65
224	150	177	0,64
224	160	163	0,63
224	180	135	0,58
224	200	107	0,53
250	100	301	0,94
250	112	285	0,92
250	125	267	0,90
250	140	246	0,89
250	150	232	0,87
250	160	219	0,87
250	180	191	0,80
250	200	164	0,75
250	224	131	0,67
280	125	308	1,10
280	140	287	1,08
280	150	274	1,06
280	160	260	1,05
280	180	232	1,00
280	200	205	0,95
280	224	172	0,87
280	250	136	0,84
300	125	335	1,25
300	140	315	1,22
300	150	301	1,20
300	160	287	1,20
300	180	260	1,15
300	200	262	1,09
300	224	200	1,02
300	250	164	0,98
300	280	123	0,86
315	125	356	1,36
315	140	335	1,33
315	150	322	1,32
315	160	308	1,31
315	180	281	1,26

Ød nom	Ød ₂ nom	l mm	m kg
315	200	253	1,21
315	224	220	1,13
315	250	184	1,09
315	280	143	0,97
315	300	116	0,88
355	160	363	1,84
355	180	335	1,77
355	200	308	1,71
355	224	275	1,61
355	250	239	1,56
355	280	198	1,41
355	300	171	1,30
355	315	150	1,21
400	160	450	2,44
400	180	422	2,38
400	200	395	2,31
400	224	362	2,23
400	250	326	2,20
400	280	285	2,01
400	300	257	1,90
400	315	237	1,86
400	355	182	1,55
450	200	463	2,99
450	224	431	2,90
450	250	395	2,85
450	280	354	2,70
450	300	326	2,59
450	315	306	2,50
450	355	251	2,24
450	400	194	2,64
500	200	532	3,66
500	224	499	3,56
500	250	463	3,51
500	280	422	3,36
500	300	395	3,25
500	315	374	3,16
500	355	319	2,89
500	400	262	2,69
500	450	194	2,37
560	250	546	4,47
560	280	505	4,32
560	300	477	4,21
560	315	456	4,11
560	355	402	3,85
560	400	345	3,66
560	450	276	2,70
560	500	207	2,86
600	250	601	5,10

- 1
- 2
- 3
- 4
- 5
- 6
- 7
- 8
- 9
- 10
- 11
- 12
- 13
- 14
- 15
- 16
- 17
- 18

Ød nom	Ød ₂ nom	l mm	m kg
600	280	560	4,96
600	300	532	4,84
600	315	512	4,76
600	355	457	4,49
600	400	400	4,29
600	450	331	3,96
600	500	262	3,49
600	560	180	2,94
630	250	642	5,60
630	280	601	5,46
630	300	573	5,34
630	315	553	5,25
630	355	498	4,99
630	400	441	4,79
630	450	372	4,46
630	500	304	4,00
630	560	221	3,43
630	600	166	2,97
710	355	633	7,11
710	400	576	6,92
710	450	507	6,60
710	500	438	6,12
710	560	356	5,57
710	600	301	5,10
710	630	260	4,72
800	400	699	8,81
800	450	631	8,49
800	500	562	8,02
800	560	480	7,46
800	600	425	6,99
800	630	384	6,62
800	710	279	6,21
900	450	768	10,8
900	500	699	10,3
900	560	617	9,78
900	600	562	9,31
900	630	521	8,94
900	710	416	8,53
900	800	292	7,18
1000	500	857	13,1
1000	560	774	12,5
1000	600	719	12,0
1000	630	678	11,7
1000	710	573	11,2
1000	800	450	9,91
1000	900	312	8,17
1120	560	939	16,4
1120	600	884	15,9

Ød nom	Ød ₂ nom	l mm	m kg
1120	630	843	15,5
1120	710	738	15,1
1120	800	615	13,8
1120	900	477	12,1
1120	1000	656	16,2
1250	600	340	10,3
1250	630	1063	20,1
1250	710	1022	19,7
1250	800	917	19,3
1250	900	793	17,9
1250	1000	518	14,4
1250	1120	354	12,2



Description

Long, tangential, hand made reducer with approx. 35° angle.

Dimensions are otherwise adapted to DIN 24147 section 4.

Dimensions

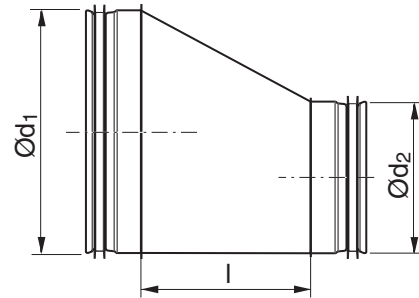

Ød ₁ nom	Ød ₂ nom	l mm	m kg
80	63	53	0,14
100	63	81	0,20
100	80	58	0,18
112	63	97	0,23
112	80	74	0,22
112	100	47	0,20
125	63	115	0,28
125	80	92	0,26
125	100	64	0,24
125	112	48	0,23
140	63	136	0,33
140	80	112	0,32
140	100	85	0,30
140	112	69	0,28
140	125	51	0,27
150	63	150	0,37
150	80	126	0,36
150	100	99	0,34
150	112	82	0,32
150	125	64	0,30
150	140	44	0,28
160	63	163	0,43
160	80	140	0,42
160	100	112	0,40
160	112	96	0,38
160	125	78	0,36
160	140	57	0,34
160	150	44	0,32
180	80	167	0,51
180	100	140	0,49
180	112	123	0,47
180	125	106	0,46
180	140	85	0,43

Ordering example

Product	RLU	200	160
Dimension Ød ₁			
Dimension Ød ₂			

Ød ₁ nom	Ød ₂ nom	l mm	m kg
180	150	71	0,41
180	160	58	0,41
200	80	195	0,61
200	100	167	0,59
200	112	151	0,57
200	125	133	0,55
200	140	112	0,53
200	150	99	0,51
200	160	85	0,50
200	180	58	0,46
224	100	200	0,72
224	112	184	0,70
224	125	166	0,68
224	140	145	0,65
224	150	132	0,64
224	160	118	0,63
224	180	90	0,58
224	200	63	0,53
250	100	236	0,94
250	112	220	0,92
250	125	202	0,90
250	140	181	0,89
250	150	167	0,87
250	160	154	0,87
250	180	126	0,80
250	200	99	0,75
250	224	66	0,67
280	125	243	1,10
280	140	222	1,08
280	150	209	1,06
280	160	195	1,05
280	180	167	1,00
280	200	140	0,95
280	224	107	0,87
280	250	71	0,84
300	125	270	1,25
300	140	250	1,22
300	150	236	1,20
300	160	222	1,20
300	180	195	1,15
300	200	167	1,09
300	224	135	1,02
300	250	99	0,98
300	280	58	0,86
315	125	291	1,36
315	140	270	1,33
315	150	257	1,32
315	160	243	1,31

Ød ₁ nom	Ød ₂ nom	l mm	m kg
315	180	216	1,26
315	200	188	1,21
315	224	155	1,13
315	250	119	1,09
315	280	78	0,97
315	300	51	0,88
355	160	298	1,84
355	180	270	1,77
355	200	243	1,71
355	224	210	1,61
355	250	174	1,56
355	280	133	1,41
355	300	106	1,30
355	315	85	1,21
400	160	365	2,44
400	180	337	2,38
400	200	310	2,31
400	224	277	2,23
400	250	241	2,20
400	280	200	2,01
400	300	172	1,90
400	315	152	1,86
400	355	97	1,55
450	200	378	2,99
450	224	346	2,90
450	250	310	2,85
450	280	269	2,70
450	300	241	2,59
450	315	221	2,50
450	355	166	2,24
450	400	109	2,64
500	200	447	3,66
500	224	414	3,56
500	250	378	3,51
500	280	337	3,36
500	300	310	3,25
500	315	289	3,16
500	355	234	2,89
500	400	177	2,69
500	450	109	2,37
560	250	461	4,47
560	280	420	4,32
560	300	392	4,21
560	315	371	4,11
560	355	317	3,85
560	400	260	3,66
560	450	191	2,70
560	500	122	2,86

Reducer

Ød ₁ nom	Ød ₂ nom	l mm	m kg
600	250	516	5,10
600	280	475	4,96
600	300	447	4,84
600	315	427	4,76
600	355	372	4,49
600	400	315	4,29
600	450	246	3,96
600	500	177	3,49
600	560	95	2,94
630	250	557	5,60
630	280	516	5,46
630	300	488	5,34
630	315	468	5,25
630	355	413	4,99
630	400	356	4,79
630	450	287	4,46
630	500	219	4,00
630	560	136	3,43
630	600	81	2,97
710	355	528	7,11
710	400	471	6,92
710	450	402	6,60
710	500	333	6,12
710	560	251	5,57
710	600	196	5,10
710	630	155	4,72
800	400	594	8,81
800	450	526	8,49
800	500	457	8,02
800	560	375	7,46
800	600	320	6,99
800	630	279	6,62
800	710	174	6,21
900	450	663	10,8
900	500	594	10,3
900	560	512	9,78
900	600	457	9,31
900	630	416	8,94
900	710	311	8,53
900	800	187	7,18
1000	500	732	13,1
1000	560	649	12,5
1000	600	594	12,0
1000	630	553	11,7
1000	710	448	11,2
1000	800	325	9,91
1000	900	187	8,17
1120	560	814	16,4

Ød ₁ nom	Ød ₂ nom	l mm	m kg
1120	600	759	15,9
1120	630	718	15,5
1120	710	613	15,1
1120	800	490	13,8
1120	900	352	12,1
1120	1000	215	10,3
1250	600	938	20,1
1250	630	897	19,7
1250	710	792	19,3
1250	800	668	17,9
1250	900	531	16,2
1250	1000	393	14,4
1250	1120	229	12,2

1

2

3

4

5

6

7

8

9

10

11

12

13

14

15

16

17

18

1

2

3

4

5



6

Description

Pressed saddle with aerodynamic flow radius facing the branch.

7

Some PSUs are pressed with one and the same tool, and fit several dimensions of main pipe.

8

9

10

11

12

13

14

15

16

Ordering example

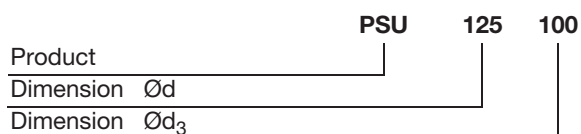

17

18

Dimensions

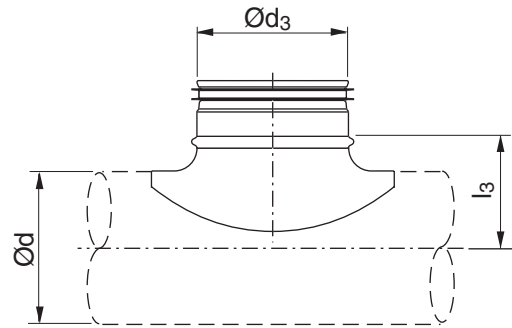

Ød nom	Ød ₃ nom	l ₃ mm	m kg
63	63	42	0,09
80	63	50	0,09
80	80	52	0,13
100	63	60	0,09
100	80	60	0,14
100	100	65	0,18
112	63	66	0,09
112	80	68	0,13
112	100	71	0,18
112 *	112	81	0,21
125	63	73	0,08
125	80	75	0,13
125	100	78	0,18
125 *	112	88	0,21
125	125	83	0,25
140	80	82	0,13
140	100	85	0,18
140 *	112	95	0,21
140 *	125	95	0,22
140	140	90	0,25
150	80	87	0,10
150	100	90	0,18
150	125	95	0,18
150	140	95	0,25
150	150	95	0,25
160	80	92	0,10
160	100	95	0,18
160	125	100	0,18
160	140	100	0,25
160	150	100	0,32
160	160	105	0,26
180	80	102	0,09
180	100	105	0,19

Ød nom	Ød ₃ nom	l ₃ mm	m kg
180	125	110	0,25
180	140	110	0,25
180	150	110	0,22
180	160	115	0,27
180	180	115	0,48
200	80	112	0,09
200	100	115	0,19
200	125	115	0,25
200	140	120	0,25
200	150	120	0,22
200	160	125	0,27
200	180	125	0,45
200	200	125	0,39
224	80	124	0,12
224	100	127	0,18
224	125	132	0,23
224	140	132	0,29
224	150	132	0,21
224	160	137	0,24
224	180	137	0,41
224 *	200	137	0,47
224	224	137	0,64
250	80	137	0,12
250	100	140	0,18
250	125	145	0,23
250	140	145	0,29
250	150	145	0,21
250	160	150	0,24
250	180	150	0,41
250	200	150	0,34
250	224	150	0,63
250	250	150	0,80
280	80	155	0,12
280	100	155	0,12
280	125	160	0,23
280	140	160	0,27
280	150	160	0,21
280	160	165	0,24
280	180	165	0,40
280	200	165	0,46
280	224	165	0,58
280 *	250	165	0,77
280 *	280	165	0,59
300	80	162	0,12
300	100	165	0,12
300	125	170	0,23
300	140	170	0,27
300	150	170	0,21

Ød nom	Ød ₃ nom	l ₃ mm	m kg
300	160	175	0,24
300	180	175	0,40
300	200	175	0,46
300	224	175	0,58
300	250	175	0,71
300 *	280	175	0,59
300	300	175	1,13
315	80	170	0,12
315	100	173	0,12
315	125	178	0,23
315	140	178	0,27
315	150	178	0,21
315	160	182	0,24
315	180	182	0,40
315	200	182	0,34
315	224	182	0,58
315	250	182	0,71
315 *	280	182	0,95
315	300	182	1,10
315	315	182	1,22
355	100	193	0,12
355	125	198	0,23
355	140	198	0,27
355	150	198	0,21
355	160	203	0,24
355	180	203	0,40
355	200	203	0,44
355	224	203	0,58
355	250	203	0,65
355 *	280	203	0,89
355	300	203	0,94
355 *	315	203	1,12
355 *	355	203	0,90
400	100	215	0,12
400	125	220	0,23
400	150	220	0,24
400	160	225	0,24
400	200	225	0,44
400	224	225	0,54
400	250	225	0,65
400 *	280	225	0,83
400	300	250	0,94
400	315	225	1,03
400 *	355	225	1,42
400	400	225	1,87
450	100	240	0,12
450	125	245	0,23
450	150	245	0,24

Ød nom	Ød ₃ nom	l ₃ mm	m kg
450	160	250	0,25
450	200	250	0,42
450	224	250	0,54
450	250	250	0,67
450 *	280	250	0,77
450	300	250	0,83
450	315	250	0,94
450 *	355	250	1,01
450	400	250	1,81
450 *	450	250	1,58
500	100	265	0,12
500	125	270	0,23
500	150	270	0,24
500	160	275	0,25
500	200	275	0,42
500	224	275	0,54
500	250	275	0,67
500	300	275	0,83
500	315	275	0,93
500 *	355	275	1,01
500	400	275	1,75
500 *	450	275	1,45
500 *	500	290	1,87
560	100	295	0,12
560	125	300	0,23
560	160	305	0,25
560	200	305	0,42
560	224	305	0,54
560	250	305	0,67
560	300	305	0,83
560	315	305	0,93
560 *	355	305	1,06
560	400	305	1,75
560 *	450	305	1,37
560 *	500	320	1,75
560 *	560	320	2,24
600	100	315	0,12
600	125	320	0,23
600	160	325	0,31
600	200	325	0,40
600	224	325	0,54
600	250	325	0,65
600	300	325	0,83
600	315	325	0,93
600 *	355	325	0,94
600	400	325	1,49
600 *	450	325	1,34
600 *	500	340	1,60

Ød nom	Ød ₃ nom	l ₃ mm	m kg
600 *	560	340	2,09
600 *	600	340	2,47
630	100	330	0,12
630	125	335	0,23
630	160	340	0,31
630	200	340	0,40
630	224	340	0,54
630	250	340	0,83
630	300	340	0,55
630	315	340	0,93
630 *	355	340	0,80
630	400	340	1,49
630 *	450	340	1,82
630 *	500	355	1,53
630 *	560	355	2,09
630 *	600	355	2,35
630 *	630	355	2,53

* Hand made without radius.



Description

As standard the angle is 45°.
Different angle available to order.

Dimensions

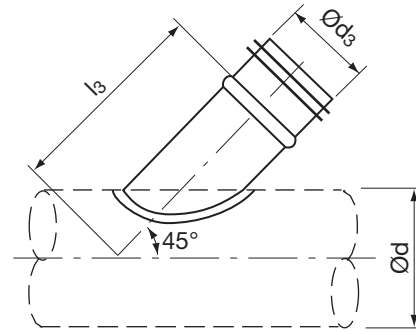

Ød nom	Ød ₃ nom	l ₃ mm	m kg
80	80	165	0,20
100	80	180	0,20
100	100	190	0,30
125	80	200	0,20
125	100	210	0,30
125	112	215	0,30
125	125	220	0,40
140	80	210	0,20
140	100	220	0,30
140	112	225	0,30
140	125	230	0,40
140	140	250	0,50
150	80	215	0,20
150	100	225	0,30
150	112	235	0,30
150	125	240	0,40
150	140	260	0,50
150	150	265	0,50
160	80	220	0,20
160	100	230	0,30
160	112	240	0,30
160	125	245	0,40
160	140	265	0,50
160	150	270	0,50
160	160	275	0,60
180	80	235	0,20
180	100	245	0,30
180	112	250	0,30
180	125	260	0,40
180	140	280	0,50
180	150	285	0,50
180	160	290	0,60
180	180	300	0,90

Ordering example

Product	PSVU45	125	100
Dimension Ød			
Dimension Ød ₃			

Ød nom	Ød ₃ nom	l ₃ mm	m kg
200	80	250	0,20
200	100	260	0,30
200	112	265	0,30
200	125	270	0,40
200	140	295	0,50
200	150	300	0,50
200	160	305	0,60
200	180	315	0,90
200	200	325	1,00
224	100	275	0,30
224	112	285	0,30
224	125	290	0,40
224	140	310	0,50
224	150	315	0,50
224	160	320	0,60
224	180	330	0,90
224	200	340	1,00
224	224	350	1,20
250	80	287	0,20
250	100	295	0,30
250	112	300	0,30
250	125	310	0,40
250	140	330	0,50
250	150	335	0,50
250	160	340	0,60
250	180	350	0,90
250	200	360	1,00
250	224	370	1,20
250	250	385	1,60
280	112	320	0,30
280	125	330	0,40
280	140	350	0,50
280	150	355	0,50
280	160	360	0,60
280	180	370	0,90
280	200	380	1,00
280	224	390	1,20
280	250	405	1,60
280	280	435	1,80
300	125	350	0,40
300	140	365	0,50
300	150	370	0,50
300	160	375	0,60
300	180	385	0,90
300	200	395	1,00
300	224	405	1,20
300	250	420	1,60
300	280	450	2,00

Ød nom	Ød ₃ nom	l ₃ mm	m kg
300	300	460	2,20
315	80	333	0,20
315	100	343	0,30
315	125	360	0,40
315	140	375	0,50
315	150	380	0,50
315	160	385	0,60
315	180	395	0,90
315	200	405	1,00
315	224	415	1,20
315	250	430	1,60
315	280	460	1,90
315	300	470	2,20
315	315	480	2,40
355	80	361	0,20
355	100	371	0,30
355	125	388	0,40
355	150	410	0,50
355	160	415	0,60
355	180	425	0,90
355	200	435	1,00
355	224	445	1,20
355	250	460	1,60
355	280	490	2,00
355	300	500	2,20
355	315	505	2,30
355	355	525	2,80
400	80	393	0,20
400	100	403	0,30
400	125	420	0,40
400	160	445	0,60
400	180	455	0,90
400	200	465	1,00
400	224	475	1,20
400	250	490	1,60
400	280	520	1,90
400	300	530	2,20
400	315	535	2,30
400	355	555	2,80
400	400	580	4,30
450	180	490	0,90
450	200	500	1,00
450	224	510	1,20
450	250	525	1,60
450	280	555	1,90
450	300	565	2,20
450	315	570	2,30
450	355	590	2,80

Saddle

Ød nom	Ød ₃ nom	l ₃ mm	m kg
450	400	615	4,30
450	450	640	5,20
500	80	464	0,20
500	100	474	0,30
500	125	491	0,40
500	160	518	0,60
500	200	535	1,00
500	224	550	1,20
500	250	560	1,60
500	280	590	1,80
500	300	600	2,20
500	315	610	2,40
500	355	630	2,90
500	400	650	4,30
500	450	675	5,20
500	500	700	6,30
560	160	560	0,60
560	224	590	1,20
560	250	605	1,60
560	280	630	1,90
560	300	640	2,20
560	315	650	2,30
560	355	670	2,80
560	400	690	4,30
560	450	715	5,20
560	500	740	6,30
560	560	800	7,80
600	250	630	1,60
600	280	655	1,90
600	300	665	2,20
600	315	675	2,40
600	355	695	2,80
600	400	715	4,30
600	450	740	5,20
600	500	765	6,20
600	560	825	7,80
600	600	850	8,80
630	315	700	2,30
630	355	720	2,80
630	400	740	4,30
630	450	765	5,20
630	500	790	6,30
630	560	850	7,80
630	600	870	8,80
630	630	885	9,50
710	300	745	2,20
710	315	755	2,30
710	355	775	2,80

Ød nom	Ød ₃ nom	l ₃ mm	m kg
710	400	800	4,20
710	450	825	5,10
710	500	850	6,10
710	560	905	7,60
710	600	925	8,60
710	630	940	9,30
710	710	980	15,5
800	315	820	2,30
800	355	840	2,80
800	400	860	4,30
800	450	885	5,20
800	500	910	6,30
800	560	970	7,80
800	600	990	8,80
800	630	1005	9,50
800	710	1045	15,6
800	800	1090	19,0
900	355	910	2,80
900	400	935	4,30
900	450	960	5,20
900	500	980	6,30
900	560	1040	7,80
900	600	1060	8,80
900	630	1075	9,50
900	710	1115	15,6
900	800	1160	19,0
900	900	1210	23,3
1000	400	1005	4,30
1000	450	1030	5,20
1000	500	1055	6,40
1000	560	1110	7,80
1000	600	1130	8,80
1000	630	1145	9,50
1000	710	1185	15,5
1000	800	1230	19,0
1000	900	1280	23,0
1000	1000	1330	28,5
1120	500	1140	6,30
1120	560	1195	7,80
1120	600	1215	8,80
1120	630	1230	9,50
1120	710	1270	15,5
1120	800	1315	19,0
1120	900	1365	23,3
1120	1000	1415	28,5
1120	1120	1505	36,0
1250	500	1230	6,30
1250	560	1290	7,80

1
2
3
4
5
6
7
8
9
10
11
12
13
14
15
16
17
18

$\varnothing d$ nom	$\varnothing d_3$ nom	l_3 mm	m kg
1250	600	1310	8,80
1250	630	1325	9,50
1250	710	1365	15,6
1250	800	1410	19,1
1250	900	1460	23,0
1250	1000	1510	28,6
1250	1120	1595	35,9
1250	1250	1660	43,4

1

2

3

4

5

6

7

8

9

10

11

12

13

14

15

16

17

18



Description

T-piece built with PSU saddle or a fully pressed top section.

Pressure drop, see graphs on page 118.

Dimensions

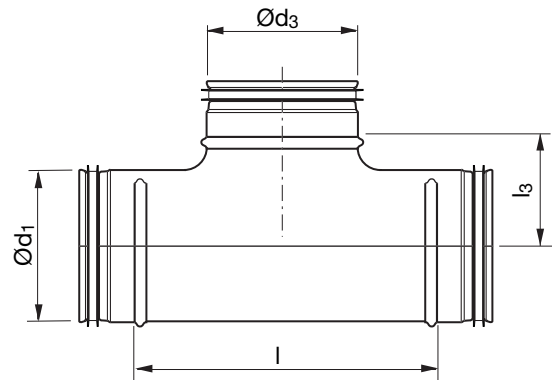
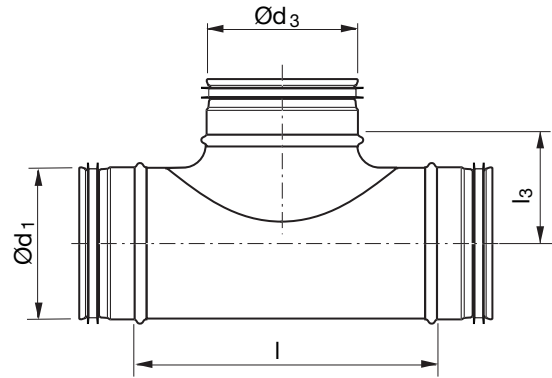

Ød ₁ nom	Ød ₃ nom	l mm	l ₃ mm	m kg
63	63	125	42	0,26
80	63	125	50	0,31
80	80	140	52	0,36
100	63	125	60	0,35
100	80	97	60	0,23
100	100	130	65	0,32
112	63	125	66	0,41
112	80	140	68	0,47
112	100	175	71	0,55
112	112 *	140	81	0,57
125	63	125	73	0,44
125	80	97	72	0,34
125	100	130	78	0,37
125	112	175	78	0,61
125	125	165	83	0,44
140	80	140	82	0,56
140	100	175	85	0,65
140	112	175	85	0,67
140	125 *	215	70	0,76
140	140	230	90	0,78
150	80	140	87	0,58
150	100	175	90	0,69
150	125	215	95	0,76
150	140	230	95	0,82

Ordering example

Product	TCPU	250	160
Dimension Ød ₁			
Dimension Ød ₃			

Ød ₁ nom	Ød ₃ nom	l mm	l ₃ mm	m kg
150	150	260	95	0,94
160	80	140	92	0,59
160	100	130	95	0,46
160	125	166	100	0,53
160	140	230	100	0,87
160	150	260	100	0,99
160	160	209	105	0,63
180	80	140	102	0,92
180	100	175	105	0,80
180	125	215	110	0,91
180	140	230	110	0,96
180	150	260	110	1,08
180	160	260	115	1,06
180	180	285	115	1,44
200	80	140	112	0,77
200	100	175	115	0,88
200	125	215	115	1,02
200	140	230	120	1,07
200	150	260	120	1,19
200	160	209	125	0,67
200	180	285	125	1,35
200	200	249	125	1,21
224	80	140	124	0,85
224	100	175	127	1,01
224	125	215	132	1,14
224	140	230	132	1,20
224	150	260	132	1,29
224	160	260	137	1,28
224	180	285	137	1,46
224	200	346	137	1,69
250	80	156	137	1,13
250	100	175	140	1,22
250	125	220	145	1,48
250	140	230	145	1,48
250	150	255	145	1,55
250	160	256	150	1,58
250	180	306	150	1,79
250	200	306	150	1,78
250	224	350	150	2,09
250	250	296	150	1,65
280	80	156	155	1,25
280	100	175	155	1,37
280	125	220	160	1,56
280	140	230	160	1,63
280	150	255	160	1,72
280	160	256	165	1,75
280	180	306	165	1,97
280	200	306	165	2,01

Ød ₁ nom	Ød ₃ nom	l mm	l ₃ mm	m kg
280	224	350	165	2,27
280	250 *	350	140	2,44
280	280 *	390	140	2,67
300	80	156	162	1,36
300	100	175	165	1,47
300	125	220	170	1,68
300	140	230	170	1,74
300	150	255	170	1,86
300	160	256	175	1,87
300	180	306	175	2,12
300	200	306	175	2,15
300	224	350	175	2,41
300	250	350	175	2,50
300	280 *	390	150	2,53
300	300	430	175	3,55
315	80	156	170	1,43
315	100	175	173	1,50
315	125	220	178	1,76
315	140	230	178	1,82
315	150	355	178	2,38
315	160	256	182	1,96
315	180	306	182	2,21
315	200	306	182	2,14
315	224	350	182	2,51
315	250	350	182	2,59
315	280	390	182	3,00
315	300	430	182	3,21
315	315	363	182	2,20
355	100	175	193	1,73
355	125	220	198	1,96
355	140	230	198	2,03
355	150	255	198	2,46
355	160	256	203	2,45
355	180	306	203	2,81
355	200	306	203	2,82
355	224	350	203	3,13
355	250	350	203	3,18
355	280 *	390	178	3,63
355	300	430	203	3,87
355	315	455	203	4,06
355	355 *	470	203	5,14
400	100	175	215	2,27
400	125	225	220	2,81
400	160	266	225	3,02
400	200	300	225	3,37
400	224	350	225	3,74
400	250	350	225	3,79
400	280 *	390	200	4,23

Ød ₁ nom	Ød ₃ nom	l mm	l ₃ mm	m kg
400	300	430	225	4,47
400	315	415	225	4,42
400	355 *	470	225	5,04
400	400	510	225	6,20
450	100	175	240	2,76
450	125	225	245	3,15
450	160	266	250	3,38
450	200	300	250	3,75
450	224	350	250	4,16
450	250	350	250	4,23
450	280 *	390	225	4,64
450	300	430	250	4,89
450	315	415	250	4,82
450	355	470	250	5,16
450	400	510	250	5,81
450	450 *	550	225	6,99
500	100	175	265	3,06
500	125	225	270	3,35
500	160	266	275	3,77
500	200	300	275	4,14
500	250	350	275	4,68
500	300	430	275	5,36
500	315	415	275	5,30
500	355	470	275	5,70
500	400	510	275	6,34
500	450 *	550	250	6,56
500	500 *	552	290	8,27
560	100	175	295	3,59
560	125	225	300	3,92
560	160	266	305	4,41
560	200	300	305	4,78
560	250	350	305	5,38
560	300	430	280	5,86
560	315	415	305	6,06
560	355	470	305	6,57
560	400	510	305	7,08
560	450 *	550	280	7,38
560	500 *	552	280	7,57
560	560 *	610	280	9,69
600	100	175	315	3,83
600	125	225	320	4,19
600	160	266	325	4,73
600	200	300	325	5,10
600	250	350	325	5,73
600	300 *	430	300	6,36
600	315	415	325	6,46
600	355 *	470	300	6,98
600	400	510	325	7,43

Ød ₁ nom	Ød ₃ nom	l mm	l ₃ mm	m kg
600	450 *	550	300	7,84
600	500 *	552	300	7,91
600	560 *	610	300	8,76
600	600 *	650	300	10,8
630	100	175	330	4,03
630	125	225	335	4,41
630	160	266	340	4,99
630	200	300	340	5,35
630	250	350	340	6,00
630	300 *	450	315	7,23
630	315	415	340	6,77
630	355 *	470	315	7,18
630	400	510	340	7,69
630	450 *	555	315	8,24
630	500 *	552	340	8,44
630	560 *	610	315	9,11
630	600 *	650	315	9,58
630	630 *	680	340	11,3

* Hand made with saddle without radius.

Supply air

1

Diverging flow

2

3

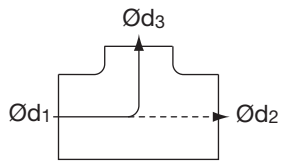

4

5

6

7

Diverging flow

8

9

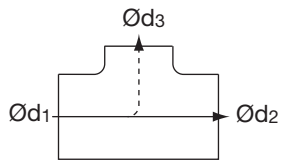

10

The diagram is also applicable to reduction in Ød_2 .

11

12

Diverging flow

13

14

15

16

17

18

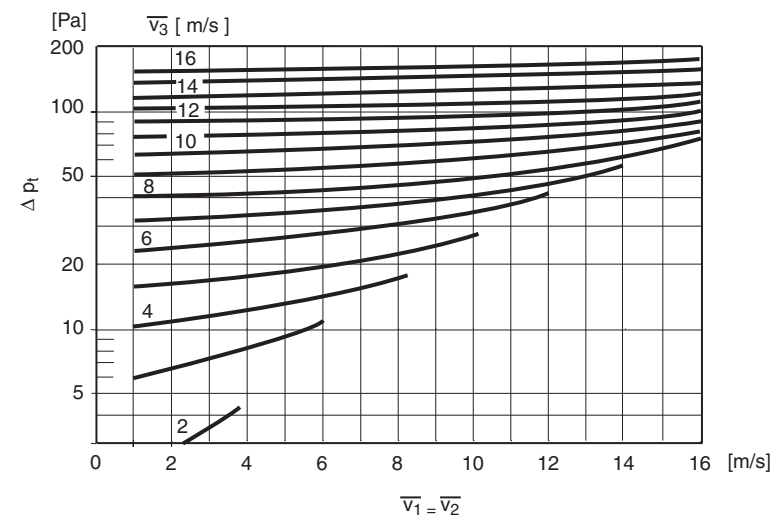
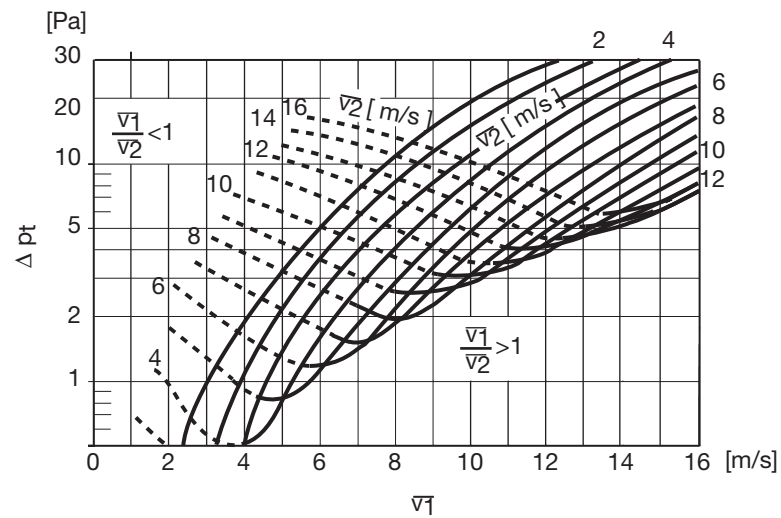
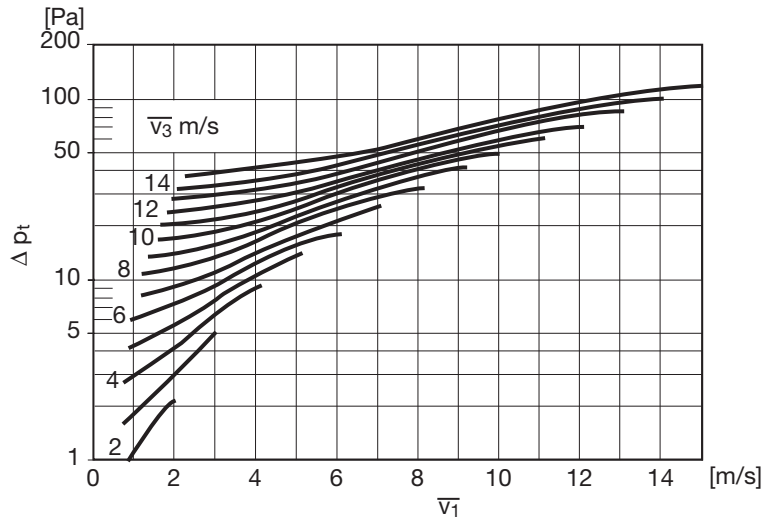

Exhaust air

Converging flow

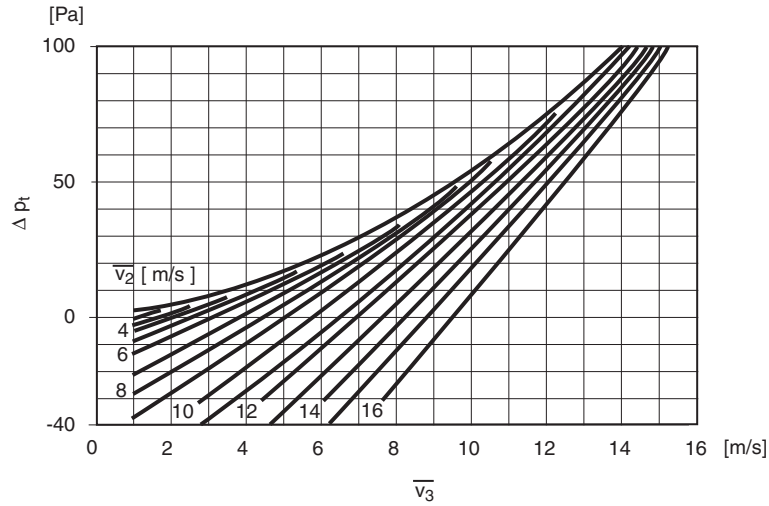
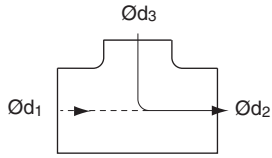

Converging flow

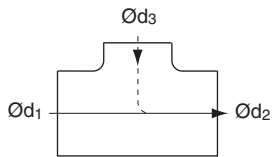

The diagram is also applicable to reduction in Ød_1 .

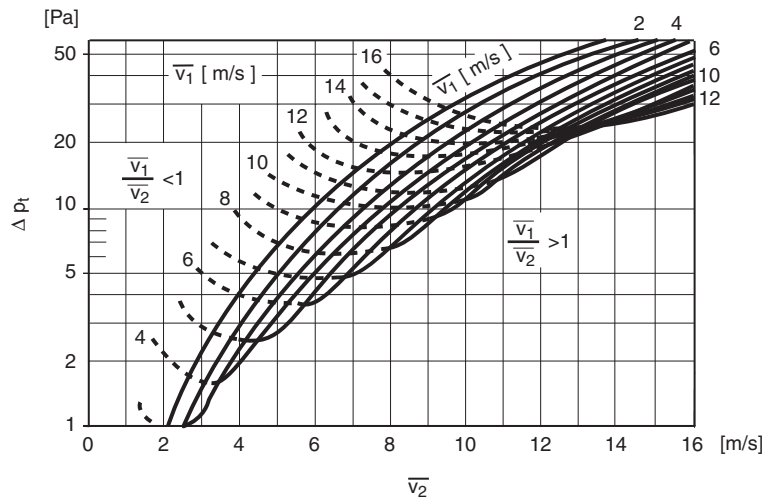

Converging flow

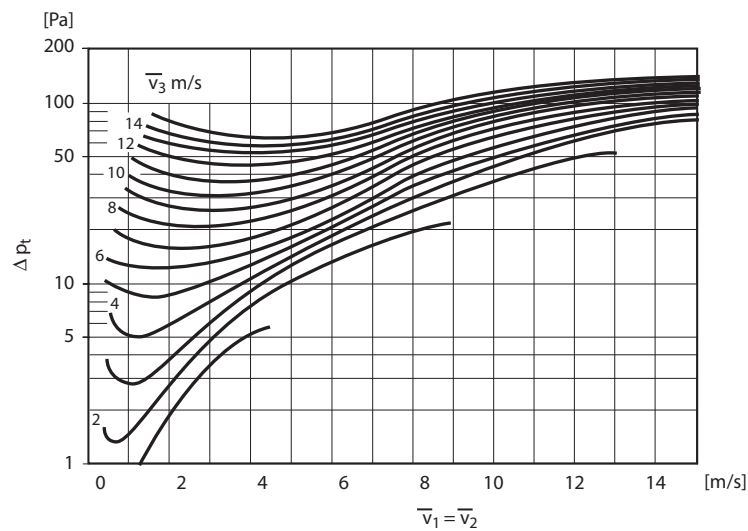
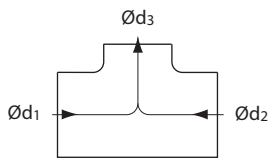

- 1
- 2
- 3
- 4
- 5
- 6
- 7
- 8
- 9
- 10
- 11
- 12
- 13
- 14
- 15
- 16
- 17
- 18

T-piece – Casting-in programme

TCSIU



Dimensions

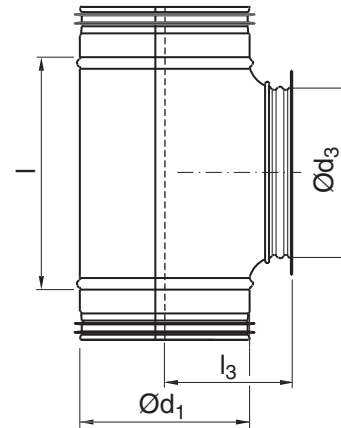

Description

Short branch with air valve socket and nail flange with pre-punched holes.

Fits air valve KVB etc.

Ød ₁ nom	Ød ₃ nom	l mm	l ₃ mm	m kg
100	100	130	93	0,31
125	100	130	106	0,52
125	125	165	106	0,67
160	160	229	131	1,02

Ordering example

	TCSIU	100	100	GJUT
Product				
Dimension Ød ₁				
Branch Ød ₃				
Specification				

T-piece – Casting-in programme

TCPU



Description

Short branch with female end and nail flange with pre-punched holes.

Dimensions

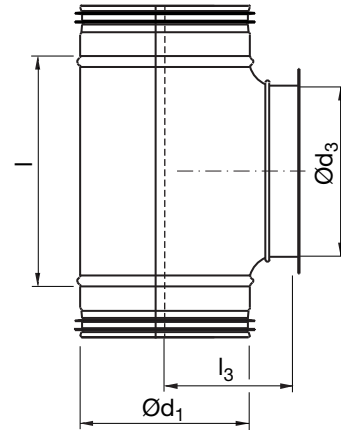

Ød ₁ nom	Ød ₃ nom	l mm	l ₃ mm	m kg
80 *	80	140	80	0,38
100	100	130	93	0,30
125	100	130	106	0,50
125	125	165	102	0,59
160	160	209	130	0,88

* Made with saddle PS

Ordering example

	TCPU	100	100	GJUT
Product				
Dimension Ød ₁				
Branch Ød ₃				
Specification				



T-piece – Casting-in programme

TCPU



Dimensions

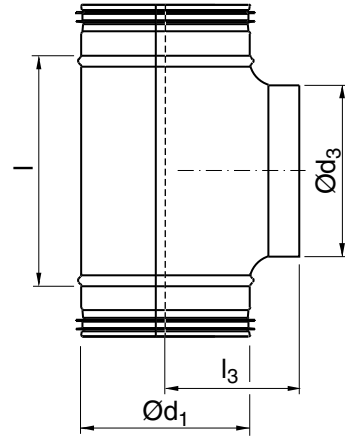

Description

Short branch with female end.

Ød ₁ nom	Ød ₃ nom	l mm	l ₃ mm	m kg
80 *	80	140	80	0,33
100	100	130	85	0,27
125	100	130	100	0,44
125	125	165	100	0,53
160	160	229	117	0,82

* Made with saddle PS

Ordering example

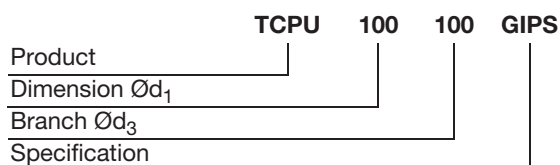

T-piece – Casting-in programme

TCPU



Description

Short branch and short installation lengths.

Dimensions

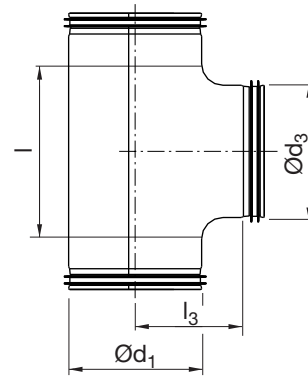

Ød ₁ nom	Ød ₃ nom	l mm	l ₃ mm	m kg
100	100	123	65	0,31
125	125	157	83	0,43
160	160	203	105	0,62

Ordering example

	TCPU	100	100	KORT
Product				
Dimension Ød ₁				
Dimension Ød ₃				
Specification				

- 1
- 2
- 3
- 4
- 5
- 6
- 7
- 8
- 9
- 10
- 11
- 12
- 13
- 14
- 15
- 16
- 17
- 18



Dimensions

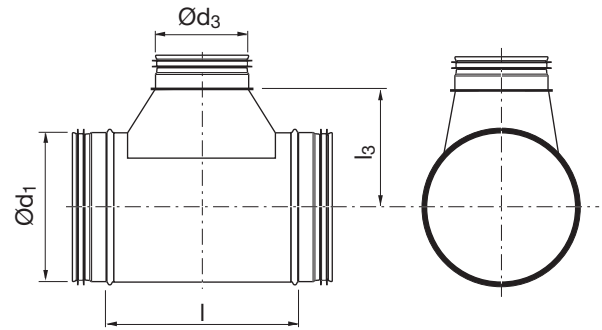

Description

Centric T-piece with hand made T-piece TSTCU.

Ød ₁ nom	Ød ₃ nom	l mm	l ₃ mm	m kg
63	80	195	77	0,33
63	100	215	77	0,38
80	112	225	85	0,48
80	125	240	85	0,53
100	112	225	95	0,52
100	125	240	95	0,56
100	140	260	100	0,63
100	150	270	100	0,63
100	160	280	100	0,68
112	112	225	100	0,60
112	140	260	105	0,71
112	150	270	105	0,74
112	160	280	105	0,77
112	180	300	105	0,83
125	140	260	115	0,72
125	150	270	115	0,75
125	160	280	115	0,77
125	180	300	115	0,85
125	200	335	130	1,01
140	63	178	115	0,60
140	125	240	115	0,75
140	150	270	120	0,85
140	160	280	120	0,88
140	180	300	120	0,95
140	200	335	135	1,09
140	224	360	135	1,19
150	63	178	120	0,59
150	112	225	120	0,75
150	180	300	125	0,99
150	200	335	140	1,17
150	224	360	140	1,24
150	250	385	140	1,40
160	63	178	125	0,58

Ordering example



T-piece

Ød ₁ nom	Ød ₃ nom	l mm	l ₃ mm	m kg
160	200	335	145	1,21
160	224	360	145	1,30
160	250	385	145	1,52
180	63	178	135	0,69
180	112	225	135	0,87
180	200	335	155	1,32
180	224	360	155	1,41
180	250	385	155	1,58
180	280	425	165	1,98
200	63	178	145	0,74
200	112	225	145	0,92
200	224	360	165	1,50
200	250	385	165	1,68
200	280	425	175	2,06
200	300	445	175	2,19
200	315	460	175	2,11
224	63	178	160	0,83
224	112	225	160	1,02
224	250	385	180	1,94
224	280	425	190	2,21
224	300	445	190	2,33
224	315	460	190	2,42
224	355	510	200	2,80
250	63	178	170	1,05
250	112	225	170	1,12
250	280	425	200	2,36
250	300	445	200	2,49
250	315	460	200	2,55
250	355	510	210	2,97
250	400	555	210	3,56
280	112	225	185	1,24
280	250	385	205	2,27
280	280	425	215	2,51
280	300	445	215	2,65
280	315	460	215	2,75
280	355	510	225	3,13
280	400	555	225	3,74
280	450	605	225	4,14
300	112	225	195	1,34
300	280	425	225	2,64
300	315	460	225	2,87
300	355	510	235	3,28
300	400	555	235	3,81
300	450	605	235	4,29
315	112	235	205	1,38
315	355	520	245	3,44
315	400	565	245	3,99
315	450	615	245	4,31

Ød ₁ nom	Ød ₃ nom	l mm	l ₃ mm	m kg
315	500	670	250	4,68
355	112	235	225	1,76
355	280	435	245	3,78
355	355	520	265	4,44
355	400	565	265	5,07
355	450	615	265	5,50
355	500	670	270	5,99
355	560	730	270	6,51
400	112	235	245	1,97
400	140	270	250	2,31
400	150	280	250	2,40
400	180	310	250	2,68
400	280	435	275	4,16
400	355	520	285	4,85
400	450	615	285	5,99
400	500	670	290	6,59
400	560	730	290	7,11
400	600	770	290	7,47
400	630	800	290	7,73
450	140	270	275	2,52
450	150	280	275	2,62
450	180	310	275	2,94
450	280	435	300	4,72
450	450	615	310	6,44
450	500	670	315	7,16
450	560	730	315	7,78
450	600	770	315	8,19
450	630	800	315	8,50
450	710	880	315	9,85
500	140	270	300	2,79
500	150	280	300	2,90
500	180	310	300	3,18
500	224	370	315	3,87
500	280	435	325	4,99
500	450	615	335	7,15
500	500	670	340	7,81
500	560	730	340	8,60
500	600	770	340	9,19
500	630	800	340	9,41
500	710	880	340	11,5
500	800	970	340	11,8
560	224	370	345	4,33
560	280	435	355	5,56
560	450	615	365	8,01
560	500	670	370	8,56
560	560	730	370	9,21
560	600	770	370	9,80
560	630	800	370	10,3

- 1
- 2
- 3**
- 4
- 5
- 6
- 7
- 8
- 9
- 10
- 11
- 12
- 13
- 14
- 15
- 16
- 17
- 18

1

2

3

4

5

6

7

8

9

10

11

12

13

14

15

16

17

18

Ød ₁ nom	Ød ₃ nom	l mm	l ₃ mm	m kg
560	710	880	370	12,1
560	800	970	370	13,7
560	900	1090	370	15,6
600	224	370	365	4,62
600	280	435	375	5,93
600	300	455	375	6,15
600	355	520	385	6,99
600	450	615	385	8,55
600	500	670	390	9,16
600	560	730	390	9,63
600	600	770	390	10,5
600	630	800	390	10,7
600	710	880	390	12,6
600	800	970	390	14,1
600	900	1090	390	16,1
630	224	380	380	4,84
630	280	445	390	6,21
630	300	465	390	6,44
630	355	530	400	7,23
630	450	625	400	8,95
630	500	680	405	9,72
630	560	740	405	10,2
630	600	780	405	10,4
630	630	810	405	10,8
630	710	890	405	12,9
630	800	980	405	14,4
630	900	1100	405	16,4
630	1000	1200	405	18,3
710	250	455	420	6,34
710	280	495	420	7,00
710	300	515	430	7,26
710	315	530	430	7,46
710	355	580	440	8,24
710	400	625	440	9,49
710	450	675	440	10,1
710	500	730	445	10,9
710	560	790	445	11,6
710	600	830	445	12,1
710	630	860	445	12,3
710	710	940	445	14,1
710	800	1030	445	15,7
710	900	1150	445	17,8
710	1000	1250	445	19,8
710	1120	1370	445	23,2
800	250	455	465	8,49
800	280	495	475	9,46
800	300	515	475	9,80
800	315	530	475	9,99

Ød ₁ nom	Ød ₃ nom	l mm	l ₃ mm	m kg
800	355	580	485	11,1
800	400	625	485	12,6
800	450	675	485	13,4
800	500	730	490	14,6
800	560	790	490	15,3
800	600	830	490	15,8
800	630	860	490	16,5
800	710	940	490	18,0
800	800	1030	490	19,5
800	900	1150	490	21,5
800	1000	1250	490	22,6
800	1120	1370	490	27,6
800	1250	1500	490	30,8
900	315	530	525	11,5
900	355	580	535	12,8
900	400	625	535	15,0
900	450	675	535	15,7
900	500	730	540	16,9
900	560	790	540	18,2
900	600	830	540	19,0
900	630	860	540	19,6
900	710	940	540	22,2
900	800	1030	540	23,8
900	900	1150	540	26,1
900	1000	1250	540	29,1
900	1120	1370	540	34,1
900	1250	1500	540	38,5
1000	315	530	575	12,7
1000	355	580	585	14,1
1000	400	625	585	16,1
1000	450	675	585	17,3
1000	500	730	590	18,4
1000	560	790	590	20,1
1000	600	830	590	21,0
1000	630	860	590	22,0
1000	710	940	590	24,7
1000	800	1030	590	26,8
1000	900	1150	590	29,1
1000	1000	1250	590	31,8
1000	1120	1370	590	37,4
1000	1250	1500	590	42,5
1120	500	730	650	20,5
1120	560	790	650	22,3
1120	600	830	650	23,3
1120	630	860	650	24,1
1120	710	940	650	27,5
1120	800	1030	650	29,9
1120	900	1150	650	32,9

T-piece

$\varnothing d_1$ nom	$\varnothing d_3$ nom	l mm	l_3 mm	m kg
1120	1000	1250	650	35,0
1120	1120	1370	650	40,0
1120	1250	1500	650	45,3
1250	500	730	715	22,9
1250	560	790	715	24,6
1250	600	830	715	25,8
1250	630	860	715	26,7
1250	710	940	715	30,4
1250	800	1030	715	33,1
1250	900	1150	715	36,5
1250	1000	1250	715	39,2
1250	1120	1370	715	43,9
1250	1250	1500	715	48,4

1

2

3

4

5

6

7

8

9

10

11

12

13

14

15

16

17

18



Dimensions

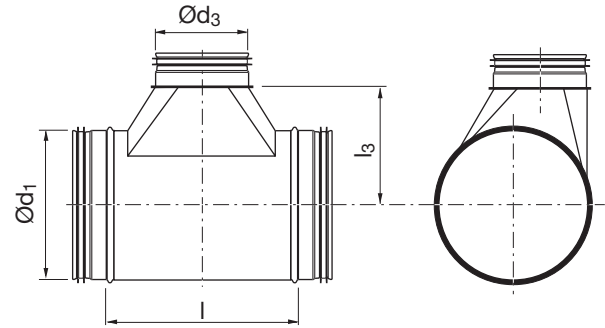

Description

Tangential T-piece with hand made T-piece TSTU.

Ød ₁ nom	Ød ₃ nom	l mm	l ₃ mm	m kg
63	63	178	77	0,28
63	80	195	77	0,33
63	100	215	77	0,38
80	63	178	85	0,34
80	80	195	85	0,38
80	100	215	85	0,44
80	112	225	85	0,48
80	125	240	85	0,53
100	63	178	95	0,41
100	80	195	95	0,45
100	100	215	95	0,49
100	112	225	95	0,52
100	125	240	95	0,56
100	140	260	100	0,63
100	150	270	100	0,63
100	160	280	100	0,68
112	63	178	100	0,50
112	80	195	100	0,54
112	100	215	100	0,59
112	112	225	100	0,60
112	125	240	100	0,65
112	140	260	105	0,71
112	150	270	105	0,74
112	160	280	105	0,77
112	180	300	105	0,83
125	63	178	110	0,51
125	80	195	110	0,55
125	100	215	110	0,59
125	112	225	110	0,61
125	125	240	110	0,65
125	140	260	115	0,72
125	150	270	115	0,75
125	160	280	115	0,77

Ordering example

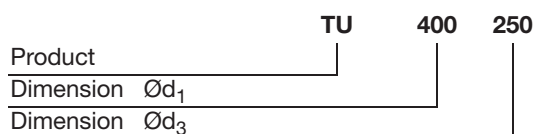

T-piece

Ød ₁ nom	Ød ₃ nom	l mm	l ₃ mm	m kg
125	180	300	115	0,85
125	200	335	130	1,01
140	63	178	115	0,60
140	80	195	115	0,65
140	100	215	115	0,69
140	112	225	115	0,72
140	125	240	115	0,75
140	140	260	120	0,81
140	150	270	120	0,85
140	160	280	120	0,88
140	180	300	120	0,95
140	200	335	135	1,09
140	224	360	135	1,19
150	63	178	120	0,59
150	80	195	120	0,65
150	80	195	120	0,65
150	100	215	165	0,70
150	112	225	120	0,75
150	125	240	120	0,80
150	140	260	125	0,86
150	150	270	125	0,89
150	160	280	125	0,92
150	180	300	125	0,99
150	200	335	140	1,17
150	224	360	140	1,24
150	250	385	140	1,40
160	63	178	125	0,58
160	80	195	125	0,65
160	100	215	125	0,72
160	112	225	125	0,76
160	125	240	125	0,82
160	140	260	130	0,89
160	150	270	130	0,91
160	160	280	130	0,93
160	180	300	130	1,04
160	200	335	145	1,21
160	224	360	145	1,30
160	250	385	145	1,52
180	63	178	135	0,69
180	80	195	135	0,76
180	100	215	135	0,82
180	112	225	135	0,87
180	125	240	135	0,90
180	140	260	140	1,00
180	150	270	140	1,03
180	160	280	140	1,07
180	180	300	140	1,12
180	200	335	155	1,32

Ød ₁ nom	Ød ₃ nom	l mm	l ₃ mm	m kg
180	224	360	155	1,41
180	250	385	155	1,58
180	280	425	165	1,98
200	63	178	145	0,74
200	80	195	145	0,95
200	100	215	145	0,87
200	112	225	145	0,92
200	125	240	145	0,96
200	140	260	150	1,07
200	150	270	150	1,10
200	160	280	150	1,12
200	180	300	150	1,19
200	200	335	165	1,42
200	224	360	165	1,50
200	250	380	165	1,68
200	280	425	175	2,06
200	300	445	175	2,19
200	315	460	175	2,11
224	63	178	160	0,83
224	80	195	160	0,90
224	100	215	160	0,98
224	112	225	160	1,02
224	125	240	160	1,08
224	140	260	165	1,18
224	150	270	165	1,22
224	160	280	165	1,25
224	180	300	165	1,33
224	200	335	180	1,54
224	224	360	180	1,61
224	250	385	180	1,94
224	280	425	190	2,21
224	300	445	190	2,33
224	315	460	190	2,42
224	355	510	200	2,80
250	63	178	170	1,05
250	80	195	170	0,99
250	100	215	170	1,20
250	112	225	170	1,12
250	125	240	170	1,30
250	140	260	175	1,29
250	150	270	175	1,34
250	160	280	175	1,49
250	180	300	175	1,46
250	200	335	190	1,80
250	224	360	190	1,76
250	250	385	190	2,09
250	280	425	200	2,36
250	300	445	200	2,49

- 1
- 2
- 3**
- 4
- 5
- 6
- 7
- 8
- 9
- 10
- 11
- 12
- 13
- 14
- 15
- 16
- 17
- 18

Ød ₁ nom	Ød ₃ nom	l mm	l ₃ mm	m kg
250	315	460	200	2,55
250	355	510	210	2,97
250	400	555	210	3,56
280	80	195	185	1,10
280	100	215	185	1,20
280	112	225	185	1,24
280	125	240	185	1,32
280	140	260	190	1,43
280	150	270	190	1,48
280	160	280	190	1,53
280	180	300	190	1,62
280	200	335	205	1,85
280	224	360	205	1,96
280	250	385	205	2,27
280	280	425	215	2,51
280	300	445	215	2,65
280	315	460	215	2,75
280	355	510	225	3,13
280	400	555	225	3,74
280	450	605	225	4,14
300	80	195	195	1,18
300	100	215	195	1,27
300	112	225	195	1,34
300	125	240	195	1,40
300	140	260	200	1,52
300	150	270	200	1,59
300	160	280	200	1,64
300	180	300	200	1,74
300	200	335	215	2,01
300	224	360	215	2,10
300	250	385	215	2,44
300	280	425	225	2,64
300	300	445	225	2,77
300	315	460	225	2,87
300	355	510	235	3,28
300	400	555	235	3,81
300	450	605	235	4,29
315	80	205	205	1,22
315	100	225	205	1,33
315	112	235	205	1,38
315	125	250	205	1,46
315	140	270	210	1,63
315	150	280	210	1,69
315	160	290	210	1,72
315	180	310	210	1,87
315	200	345	225	2,09
315	224	370	225	2,28
315	250	395	225	2,60

Ød ₁ nom	Ød ₃ nom	l mm	l ₃ mm	m kg
315	280	435	235	2,85
315	300	455	235	2,90
315	315	470	235	3,08
315	355	520	245	3,44
315	400	565	245	3,99
315	450	615	245	4,31
315	500	670	250	4,68
355	100	225	225	1,67
355	112	235	225	1,76
355	125	250	225	1,89
355	140	270	230	2,09
355	150	280	230	2,18
355	160	290	230	2,26
355	180	310	230	2,42
355	200	345	245	2,79
355	224	370	245	2,97
355	250	395	245	3,45
355	280	435	245	3,78
355	300	455	255	3,89
355	315	470	255	3,96
355	355	520	265	4,44
355	400	565	265	5,07
355	450	615	265	5,50
355	500	670	270	5,99
355	560	730	270	6,51
400	100	225	245	1,90
400	112	235	245	1,97
400	125	250	245	2,11
400	140	270	250	2,31
400	150	280	250	2,40
400	160	290	250	2,50
400	180	310	250	2,68
400	200	345	265	3,04
400	224	370	265	3,30
400	250	395	265	3,84
400	280	435	275	4,16
400	300	455	275	4,38
400	315	470	275	4,43
400	355	520	285	4,85
400	400	565	285	5,54
400	450	615	285	5,99
400	500	670	290	6,59
400	560	730	290	7,11
400	600	770	290	7,47
400	630	800	290	7,73
450	125	250	270	2,26
450	140	270	275	2,52
450	150	280	275	2,62

T-piece

Ød ₁ nom	Ød ₃ nom	l mm	l ₃ mm	m kg
450	160	290	275	2,73
450	180	310	275	2,94
450	200	345	290	3,41
450	224	370	290	3,66
450	250	395	290	4,26
450	280	435	300	4,72
450	300	455	300	4,89
450	315	470	300	5,02
450	355	520	310	5,50
450	400	565	310	6,19
450	450	615	310	6,44
450	500	670	315	7,16
450	560	730	315	7,78
450	600	770	315	8,19
450	630	800	315	8,50
450	710	880	315	9,85
500	125	250	295	2,56
500	140	270	300	2,79
500	150	280	300	2,90
500	160	290	300	3,70
500	180	310	300	3,18
500	200	345	315	3,73
500	224	370	315	3,87
500	250	395	315	4,57
500	280	435	325	4,99
500	300	455	325	5,18
500	315	470	325	5,32
500	355	520	335	5,89
500	400	565	335	6,75
500	450	615	335	7,15
500	500	670	340	7,81
500	560	730	340	8,60
500	600	770	340	9,19
500	630	800	340	9,41
500	710	880	340	11,5
500	800	970	340	11,8
560	200	345	345	4,07
560	224	370	345	4,33
560	250	395	345	5,03
560	280	435	355	5,56
560	300	455	355	5,77
560	315	470	355	5,93
560	355	520	365	6,56
560	400	565	365	7,52
560	450	615	365	8,01
560	500	670	370	8,56
560	560	730	370	9,21
560	600	770	370	9,80

Ød ₁ nom	Ød ₃ nom	l mm	l ₃ mm	m kg
560	630	800	370	10,3
560	710	880	370	12,1
560	800	970	370	13,7
560	900	1090	370	15,6
600	200	345	365	4,34
600	224	370	365	4,62
600	250	395	365	5,37
600	280	435	375	5,93
600	300	455	375	6,15
600	315	470	375	6,32
600	355	520	385	6,99
600	400	565	385	8,01
600	450	615	385	8,55
600	500	670	390	9,16
600	560	730	390	9,63
600	600	770	390	10,5
600	630	800	390	10,7
600	710	880	390	12,6
600	800	970	390	14,1
600	900	1090	390	16,1
630	200	355	380	4,56
630	224	380	380	4,84
630	250	405	380	5,62
630	280	445	390	6,21
630	300	465	390	6,44
630	315	480	390	6,62
630	355	530	400	7,23
630	400	575	400	8,48
630	450	625	400	8,95
630	500	680	405	9,72
630	560	740	405	10,2
630	600	780	405	10,4
630	630	810	405	10,8
630	710	890	405	12,9
630	800	980	405	14,4
630	900	1100	405	16,4
630	1000	1200	405	18,3
710	250	455	420	6,34
710	280	495	420	7,00
710	300	515	430	7,26
710	315	530	430	7,46
710	355	580	440	8,24
710	400	625	440	9,49
710	450	675	440	10,1
710	500	730	445	10,9
710	560	790	445	11,6
710	600	830	445	12,1
710	630	860	445	12,3

- 1
- 2
- 3
- 4
- 5
- 6
- 7
- 8
- 9
- 10
- 11
- 12
- 13
- 14
- 15
- 16
- 17
- 18

1

2

3

4

5

6

7

8

9

10

11

12

13

14

15

16

17

18

Ød ₁ nom	Ød ₃ nom	l mm	l ₃ mm	m kg
710	710	940	445	14,1
710	800	1030	445	15,7
710	900	1150	445	17,8
710	1000	1250	445	19,8
710	1120	1370	445	23,2
800	250	455	465	8,49
800	280	495	475	9,46
800	300	515	475	9,80
800	315	530	475	9,99
800	355	580	485	11,1
800	400	625	485	12,6
800	450	675	485	13,4
800	500	730	490	14,6
800	560	790	490	15,3
800	600	830	490	15,8
800	630	860	490	16,5
800	710	940	490	18,0
800	800	1030	490	19,5
800	900	1150	490	21,5
800	1000	1250	490	22,6
800	1120	1370	490	27,6
800	1250	1500	490	30,8
900	315	530	525	11,5
900	355	580	535	12,8
900	400	625	535	15,0
900	450	675	535	15,7
900	500	730	540	16,9
900	560	790	540	18,2
900	600	830	540	19,0
900	630	860	540	19,6
900	710	940	540	22,2
900	800	1030	540	23,8
900	900	1150	540	26,1
900	1000	1250	540	29,1
900	1120	1370	540	34,1
900	1250	1500	540	38,5
1000	315	530	575	12,7
1000	355	580	585	14,1
1000	400	625	585	16,1
1000	450	675	585	17,3
1000	500	730	590	18,4
1000	560	790	590	20,1
1000	600	830	590	21,0
1000	630	860	590	22,0
1000	710	940	590	24,7
1000	800	1030	590	26,8
1000	900	1150	590	29,1
1000	1000	1250	590	31,8

Ød ₁ nom	Ød ₃ nom	l mm	l ₃ mm	m kg
1000	1120	1370	590	37,4
1000	1250	1500	590	42,5
1120	500	730	650	20,5
1120	560	790	650	22,3
1120	600	830	650	23,3
1120	630	860	650	24,1
1120	710	940	650	27,5
1120	800	1030	650	29,9
1120	900	1150	650	32,9
1120	1000	1250	650	35,0
1120	1120	1370	650	40,0
1120	1250	1500	650	45,3
1250	500	730	715	22,9
1250	560	790	715	24,6
1250	600	830	715	25,8
1250	630	860	715	26,7
1250	710	940	715	30,4
1250	800	1030	715	33,1
1250	900	1150	715	36,5
1250	1000	1250	715	39,2
1250	1120	1370	715	43,9
1250	1250	1500	715	48,4



Description

Centric T-piece with female coupling for joining fittings.

Fits very well with Lindab InCapsa.

Has Click function at the Safe ends – has an open turned-over ends.

Has normally not any Click function at the female end – hasn't any notches.

Ø 100–160 can upon order be delivered with click function at the female end as well – i.e. with notches.

Dimensions

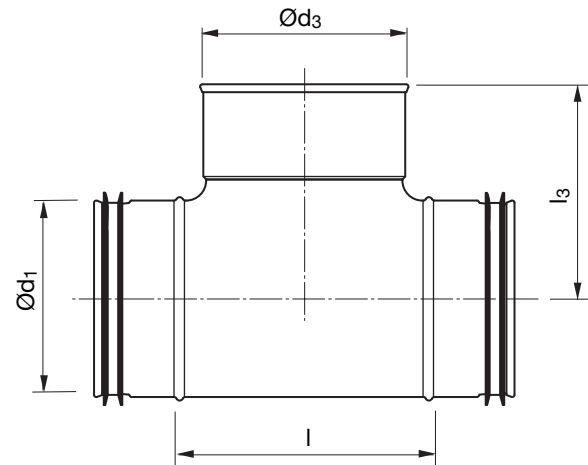

Ød ₁ nom	Ød ₃ nom	l mm	l ₃ mm	m kg
100	100	130	100	0,31
125	100	130	113	0,32
125	125	125	121	0,43
160	100	130	128	0,46
160	125	165	137	0,53
160	160	209	141	0,63

Ordering example

Product	TCPMU	125	100
Dimension Ød ₁			
Dimension Ød ₃			



Description

As standard the angle is 45°.
Different angle available to order.

Dimensions

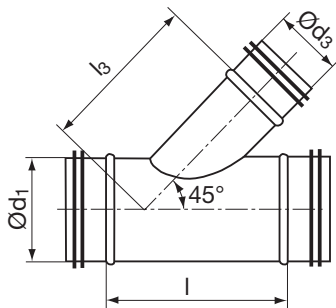

Dimensions

Ød ₁ nom	Ød ₃ nom	l mm	l ₃ mm	m kg
80	80	250	165	0,70
100	80	250	180	0,80
100	100	280	190	1,10
125	80	250	200	0,90
125	100	280	210	1,10
125	112	300	215	1,20
125	125	315	220	1,30
140	80	280	210	1,00
140	100	305	220	1,20
140	112	320	225	1,30
140	125	340	230	1,40
140	140	365	250	1,60
150	80	280	215	1,10
150	100	305	225	1,30
150	112	320	235	1,40
150	125	340	240	1,50
150	140	365	260	1,70
150	150	380	265	1,80
160	80	280	220	1,10
160	100	305	230	1,30
160	112	320	240	1,40
160	125	340	245	1,50
160	140	365	265	1,70
160	150	380	270	1,80
160	160	390	275	1,90
180	80	280	235	1,20
180	100	305	245	1,40
180	112	320	250	1,50
180	125	340	260	1,60
180	140	365	280	1,90
180	150	380	285	2,00
180	160	390	290	2,10
180	180	420	300	2,30
200	80	280	250	1,30
200	100	305	260	1,50
200	112	320	265	1,60
200	125	340	270	1,80
200	140	365	295	2,00
200	150	380	300	2,10
200	160	390	305	2,20
200	180	420	315	2,50
200	200	450	325	2,80
224	100	305	275	1,70
224	112	320	285	1,80
224	125	340	290	1,90
224	140	365	310	2,20
224	150	380	315	2,30
224	160	390	320	2,40

Ordering example

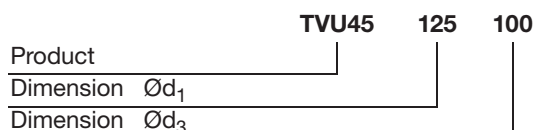

Ød ₁ nom	Ød ₃ nom	l mm	l ₃ mm	m kg
224	180	420	330	2,70
224	200	450	340	3,00
224	224	480	350	3,20
250	100	305	295	2,10
250	112	320	300	2,20
250	125	340	310	2,30
250	140	365	330	2,60
250	150	380	335	2,80
250	160	390	340	2,80
250	180	420	350	3,00
250	200	450	360	3,40
250	224	480	370	3,60
250	250	520	385	4,10
280	112	320	320	2,50
280	125	340	330	2,70
280	140	365	350	2,90
280	150	380	355	3,00
280	160	390	360	3,10
280	180	445	370	3,40
280	200	475	380	3,80
280	224	510	390	4,00
280	250	545	405	4,50
280	280	590	435	5,10
300	125	340	350	3,10
300	140	365	365	3,40
300	150	380	370	3,60
300	160	390	375	3,70
300	180	445	385	4,00
300	200	475	395	4,40
300	224	510	405	4,70
300	250	545	420	5,20
300	280	590	450	5,90
300	300	615	460	6,70
315	100	280	343	3,50
315	125	340	360	3,60
315	140	365	375	3,80
315	150	380	380	4,00
315	160	395	385	4,10
315	180	445	395	4,40
315	200	475	405	4,90
315	224	510	415	5,20
315	250	545	430	5,80
315	280	590	460	6,50
315	300	615	470	7,00
315	315	640	480	7,30
355	100	280	371	4,00
355	125	340	388	5,90
355	150	380	410	4,40
355	160	395	415	4,50
355	180	445	425	4,80
355	200	475	435	5,40

Ød ₁ nom	Ød ₃ nom	l mm	l ₃ mm	m kg
355	224	510	445	5,60
355	250	545	460	6,30
355	280	590	490	7,10
355	300	615	500	7,50
355	315	640	505	7,80
355	355	695	525	8,80
400	100	280	403	5,90
400	125	340	420	6,10
400	160	395	445	5,30
400	180	445	455	5,60
400	200	475	465	6,20
400	224	510	475	6,50
400	250	545	490	7,10
400	280	590	520	8,00
400	300	615	530	8,50
400	315	640	535	8,80
400	355	695	555	9,80
400	400	760	580	11,2
450	180	445	490	6,30
450	200	475	500	6,90
450	224	510	510	7,20
450	250	545	525	7,90
450	280	590	555	8,70
450	300	615	565	9,20
450	315	640	570	9,60
450	355	695	590	10,6
450	400	760	615	12,1
450	450	830	640	13,5
500	200	475	535	7,50
500	224	510	550	7,80
500	250	545	560	8,60
500	280	590	560	9,50
500	300	615	600	10,0
500	315	640	610	10,4
500	355	695	630	11,5
500	400	760	650	13,0
500	450	830	675	14,5
500	500	900	700	16,1
560	224	510	590	9,20
560	250	600	605	10,0
560	280	640	630	10,8
560	300	665	640	11,4
560	315	690	650	11,8
560	355	750	670	13,0
560	400	810	690	14,5
560	450	880	715	16,1
560	500	950	740	17,8
560	560	1040	800	20,4
600	250	600	630	11,5
600	280	640	655	12,5
600	300	665	665	13,1

- 1
- 2
- 3**
- 4
- 5
- 6
- 7
- 8
- 9
- 10
- 11
- 12
- 13
- 14
- 15
- 16
- 17
- 18

	Ød ₁ nom	Ød ₃ nom	l mm	l ₃ mm	m kg
1	600	315	690	675	13,6
	600	355	750	695	15,1
2	600	400	810	715	16,7
	600	450	880	740	18,4
	600	500	950	765	20,5
3	600	560	1040	825	23,4
	600	600	1090	850	25,8
	630	280	640	680	14,0
	630	300	665	690	14,6
4	630	315	690	700	15,1
	630	355	750	720	16,8
	630	400	810	740	18,7
5	630	450	880	765	20,6
	630	500	950	790	22,7
6	630	560	1040	850	25,8
	630	600	1090	870	27,8
	630	630	1140	885	29,2
7	710	300	665	745	16,9
	710	315	690	755	17,4
	710	355	750	775	19,1
8	710	400	810	800	21,0
	710	450	880	825	23,2
	710	500	950	850	25,4
9	710	560	1040	905	28,6
	710	600	1090	925	30,6
	710	630	1140	940	32,2
10	710	710	1250	980	36,7
	800	315	690	820	19,2
	800	355	750	840	21,0
11	800	400	810	860	23,1
	800	450	880	885	25,4
12	800	500	950	910	27,7
	800	560	1040	970	31,2
	800	600	1090	990	33,9
13	800	630	1140	1005	34,9
	800	710	1250	1045	39,6
	800	800	1380	1090	45,0
14	900	355	750	910	26,2
	900	400	810	935	28,8
	900	450	880	960	31,5
15	900	500	950	985	34,4
	900	560	1040	1040	38,6
	900	600	1090	1060	41,1
16	900	630	1140	1075	43,1
	900	710	1250	1115	48,7
	900	800	1380	1160	55,2
17	900	900	1520	1210	62,7
	1000	400	810	1005	31,5
18	1000	450	880	1030	34,4
	1000	500	950	1055	37,5
	1000	560	1040	1110	41,8

	Ød ₁ nom	Ød ₃ nom	l mm	l ₃ mm	m kg
	1000	600	1090	1130	44,5
	1000	630	1140	1145	46,5
	1000	710	1250	1185	52,5
	1000	800	1380	1230	59,3
	1000	900	1520	1280	67,2
	1000	1000	1660	1330	75,5
	1120	500	1005	1140	49,0
	1120	560	1090	1195	54,3
	1120	600	1140	1215	57,4
	1120	630	1190	1230	60,0
	1120	710	1305	1270	67,1
	1120	800	1430	1315	75,2
	1120	900	1570	1365	84,6
	1120	1000	1710	1415	94,7
	1120	1120	1880	1505	109
	1250	500	1005	1230	53,6
	1250	560	1090	1290	59,3
	1250	600	1140	1310	62,8
	1250	630	1190	1325	65,4
	1250	710	1305	1365	73,0
	1250	800	1430	1410	81,5
	1250	900	1570	1460	91,5
	1250	1000	1710	1510	101
	1250	1120	1880	1595	117
	1250	1250	2065	1660	132



Description

Centric –

- fully pressed or
- with saddle PSU.

Dimensions

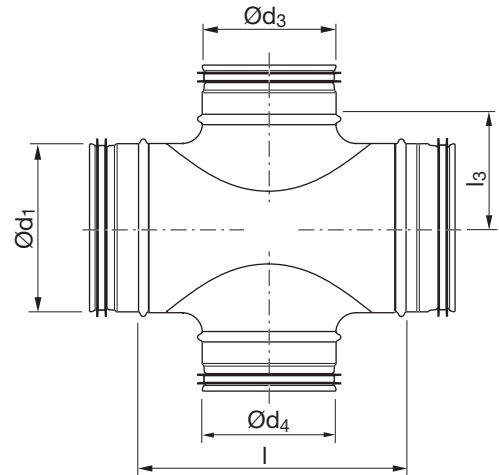

Ød ₁ nom	Ød ₃ /Ød ₄ nom	l mm	l ₃ mm	m kg
63	63	125	42	0,38
80	63	125	50	0,31
80	80	140	52	0,36
100	63	125	60	0,35
100	80	126	65	0,43
100	100	130	65	0,37
112	63	125	66	0,68
112	80	140	68	0,73
112	100	175	71	0,77
125	63	125	73	0,44
125	80	146	75	0,51
125	100	175	78	0,45
125	125	165	83	0,57
140	80	140	82	0,79
140	100	175	85	0,86
140	140	230	90	0,99
150	80	140	87	0,77
150	100	175	90	0,86
150	125	215	95	0,96
150	140	230	95	1,03
150	150	260	95	1,08
160	80	140	92	0,59
160	100	175	95	0,91
160	125	215	100	0,91
160	140	230	100	1,05
160	150	260	100	1,08
160	160	209	105	0,67
180	80	140	102	0,88
180	100	175	105	0,97
180	125	215	110	1,08
180	140	230	110	1,18
180	150	260	110	1,21
180	160	260	115	1,26

Ordering example

Product	XCPU	315	250
Dimension Ød ₁			
Dimension Ød ₃ , Ød ₄			

- 1
- 2
- 3**
- 4
- 5
- 6
- 7
- 8
- 9
- 10
- 11
- 12
- 13
- 14
- 15
- 16
- 17
- 18

Ød ₁ nom	Ød ₃ /Ød ₄ nom	l mm	l ₃ mm	m kg
180	180	285	115	1,33
200	80	140	112	0,77
200	100	175	115	0,88
200	125	215	115	1,02
200	140	230	120	1,22
200	150	260	120	1,26
200	160	260	125	0,77
200	180	285	125	1,36
200	200	249	125	1,70
224	80	140	124	0,99
224	100	175	127	1,09
224	125	215	132	1,22
224	140	230	132	1,33
224	150	260	132	1,38
224	160	260	137	1,42
224	180	285	137	1,50
224	200	346	137	1,81
224	224	346	137	1,83
250	80	156	137	1,13
250	100	175	140	1,22
250	125	220	145	1,48
250	140	230	145	1,45
250	150	255	145	1,50
250	160	256	150	1,58
250	180	306	150	1,65
250	200	306	150	1,78
250	224	350	150	1,98
250	250	296	150	1,78
280	80	156	137	1,20
280	100	175	140	1,31
280	125	220	145	1,46
280	140	230	145	1,59
280	150	255	145	1,65
280	160	256	150	1,71
280	180	306	150	1,81
280	200	306	150	2,08
280	224	350	150	2,19
300	80	156	162	1,29
300	100	175	165	1,38
300	125	220	170	1,53
300	140	230	170	1,66
300	150	255	170	1,76
300	160	256	175	1,82
300	180	306	175	1,93
300	200	306	175	2,27
300	224	350	175	2,34
300	250	350	175	2,75
300	300	445	225	3,12

Ød ₁ nom	Ød ₃ /Ød ₄ nom	l mm	l ₃ mm	m kg
315	80	156	170	1,43
315	100	175	173	1,50
315	125	220	178	1,76
315	140	230	178	1,81
315	150	255	178	1,90
315	160	256	182	1,96
315	180	306	182	2,13
315	200	306	182	2,14
315	224	350	182	2,61
315	250	350	182	2,59
315	300	430	182	3,26
315	315	363	182	3,73
355	100	175	193	1,74
355	125	220	198	2,03
355	140	230	198	2,29
355	150	255	198	2,40
355	160	256	203	2,50
355	180	306	203	2,71
355	200	306	203	3,15
355	224	350	203	3,37
355	250	350	203	3,96
355	300	430	203	4,43
400	100	175	215	2,27
400	125	225	220	2,81
400	150	255	220	2,47
400	160	266	225	3,02
400	200	300	225	3,37
400	224	350	225	3,71
400	250	350	225	3,79
400	300	430	225	4,97
400	315	415	225	4,42
400	400	510	225	6,20
450	125	225	245	2,30
450	150	255	245	2,76
450	160	266	250	2,90
450	200	300	250	3,75
450	224	350	250	4,06
450	250	350	250	4,79
450	300	430	250	5,54
450	315	415	250	5,68
450	400	510	250	6,96
500	125	225	270	3,35
500	150	255	270	3,35
500	160	266	275	3,77
500	200	300	275	4,14
500	224	350	275	4,12
500	250	350	275	4,68
500	300	430	275	5,64

$\varnothing d_1$ nom	$\varnothing d_3/\varnothing d_4$ nom	l mm	l_3 mm	m kg
500	315	415	275	5,30
500	400	510	275	6,34
560	200	300	305	4,30
560	224	350	305	4,59
560	250	350	305	5,41
560	300	430	305	6,25
560	315	415	305	6,43
560	400	510	305	8,28
600	200	300	325	4,59
600	224	350	325	4,98
600	250	350	325	5,75
600	300	350	325	6,64
600	315	415	325	6,83
600	400	510	325	8,78
630	200	300	340	5,35
630	224	350	340	5,12
630	250	350	340	6,00
630	300	430	340	6,93
630	315	415	340	6,77
630	400	510	340	7,69

1

2

3

4

5

6

7

8

9

10

11

12

13

14

15

16

17

18



Dimensions

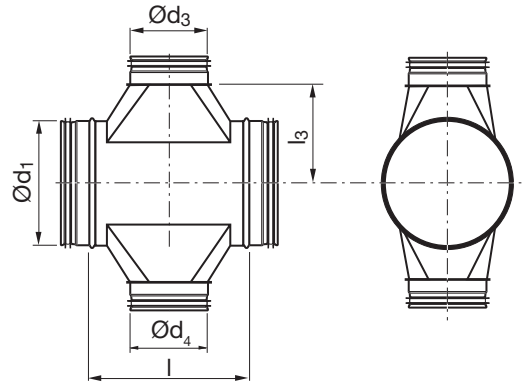

Description

Centric – with hand made T-piece TSTCU.

$\varnothing d_1$ nom	$\varnothing d_3/\varnothing d_4$ nom	l mm	l_3 mm	m kg
112	112	225	100	0,80
125	112	225	110	0,77
140	63	178	115	0,79
140	112	225	115	0,88
140	125	240	115	0,92
150	63	178	120	0,67
150	112	225	120	0,90
160	63	178	125	0,62
160	112	225	125	0,89
180	63	178	135	0,79
180	112	225	135	1,01
200	63	178	145	0,83
200	112	225	145	1,05
224	63	178	160	0,91
224	112	225	160	1,14
250	63	178	170	0,99
250	112	225	170	1,24
280	112	225	185	1,37
280	250	385	205	2,57
280	280	425	215	2,86
300	112	225	195	1,47
300	280	425	225	2,95
315	112	225	205	1,49
315	280	435	235	3,26
355	112	235	225	1,85
355	280	435	245	4,33
355	315	470	255	4,48
355	355	520	265	5,09
400	112	235	245	2,05
400	140	270	250	2,47
400	180	310	250	2,95
400	280	435	275	4,68
400	355	520	285	5,42

Ordering example

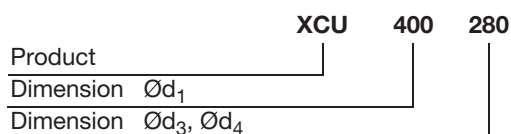

Ød ₁ nom	Ød ₃ /Ød ₄ nom	l mm	l ₃ mm	m kg
450	140	270	275	2,62
450	180	310	275	3,17
450	280	435	300	5,33
450	355	520	310	6,19
450	450	615	310	7,08
500	140	270	300	2,91
500	180	310	300	3,35
500	280	435	325	5,42
500	355	520	335	6,45
500	450	615	335	7,86
500	500	670	340	8,69
560	280	435	355	6,01
560	355	520	365	7,15
560	450	615	365	8,82
560	500	670	370	9,35
560	560	730	370	10,1
600	280	435	375	6,38
600	355	520	385	7,59
600	450	615	385	9,38
600	500	670	390	10,0
600	560	730	390	10,4
600	600	770	390	11,7
630	280	445	390	6,67
630	355	530	400	7,74
630	450	625	400	9,78
630	500	680	405	10,7
630	560	740	405	11,0
630	600	780	405	11,1
630	630	810	405	11,6
710	250	455	420	6,78
710	280	495	420	7,52
710	300	515	430	7,82
710	315	530	430	8,05
710	355	580	440	8,91
710	400	625	440	10,4
710	450	675	440	11,1
710	500	730	445	12,0
710	560	790	445	12,7
710	600	830	445	13,2
710	630	860	445	13,4
710	710	940	445	15,5
800	250	455	465	7,08
800	280	495	475	8,10
800	300	515	475	8,42
800	315	530	475	8,54
800	355	580	485	9,60
800	400	625	485	11,1
800	450	675	485	11,9

Ød ₁ nom	Ød ₃ /Ød ₄ nom	l mm	l ₃ mm	m kg
800	500	730	490	13,3
800	560	790	490	13,7
800	600	830	490	14,2
800	630	860	490	15,2
800	710	940	490	16,3
800	800	1030	490	17,9
900	315	530	525	11,9
900	355	580	535	13,2
900	400	625	535	16,0
900	450	675	535	16,5
900	500	730	540	17,9
900	560	790	540	19,2
900	600	830	540	20,1
900	630	860	540	20,7
900	710	940	540	23,7
900	800	1030	540	25,1
900	900	1150	540	27,8
1000	315	530	575	13,0
1000	355	580	585	14,3
1000	400	625	585	16,6
1000	450	675	585	17,9
1000	500	730	590	19,0
1000	560	790	590	21,0
1000	600	830	590	22,1
1000	630	860	590	23,4
1000	710	940	590	26,4
1000	800	1030	590	28,5
1000	900	1150	590	31,0
1000	1000	1250	590	34,3
1120	500	730	650	21,4
1120	560	790	650	23,1
1120	600	830	650	24,3
1120	630	860	650	25,2
1120	710	940	650	29,1
1120	800	1030	650	31,7
1120	900	1150	650	35,4
1120	1000	1250	650	37,3
1120	1120	1370	650	43,5
1250	500	730	715	23,4
1250	560	790	715	25,3
1250	600	830	715	26,6
1250	630	860	715	27,6
1250	710	940	715	31,9
1250	800	1030	715	34,9
1250	900	1150	715	39,1
1250	1000	1250	715	41,9
1250	1120	1370	715	47,1
1250	1250	1500	715	52,6



Dimensions

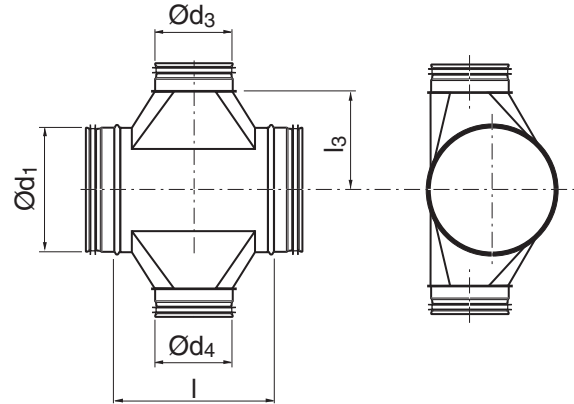

Description

Tangential –

- with hand made T-piece TSTU

Ød ₁ nom	Ød ₃ /Ød ₄ nom	l mm	l ₃ mm	m kg
80	63	178	85	0,46
100	63	178	95	0,54
100	80	195	95	0,58
112	63	178	100	0,68
112	80	195	100	0,73
112	100	215	100	0,77
125	63	178	110	0,65
125	80	195	110	0,70
125	100	215	110	0,75
125	112	225	110	0,77
140	63	178	115	0,79
140	80	195	115	0,79
140	100	215	115	0,86
140	112	225	115	0,88
140	125	240	115	0,92
150	63	178	120	0,67
150	80	195	120	0,77
150	100	215	120	0,86
150	112	225	120	0,90
150	125	240	120	0,96
150	140	260	125	1,03
160	63	178	125	0,62
160	80	195	125	0,72
160	100	215	125	0,82
160	112	225	125	0,89
160	125	240	125	0,97
160	140	260	130	1,05
160	150	270	130	1,08
180	63	178	135	0,79
180	80	195	135	0,88
180	100	215	135	0,97
180	112	225	135	1,01
180	125	240	135	1,08

Ordering example

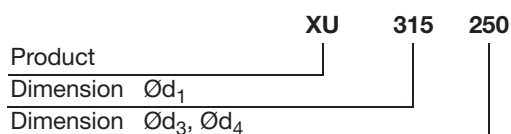

X-piece

Ød ₁ nom	Ød ₃ /Ød ₄ nom	l mm	l ₃ mm	m kg
180	140	260	140	1,18
180	150	270	140	1,21
180	160	280	140	1,26
200	63	178	145	0,83
200	80	195	145	0,91
200	100	215	145	1,00
200	112	225	145	1,05
200	125	240	145	1,11
200	140	260	150	1,22
200	150	270	150	1,26
200	160	280	150	1,30
200	180	300	150	1,36
224	63	178	160	0,91
224	80	195	160	0,99
224	100	215	160	1,09
224	112	225	160	1,14
224	125	240	160	1,22
224	140	260	165	1,33
224	150	270	165	1,38
224	160	280	165	1,42
224	180	300	165	1,50
224	200	335	180	1,81
250	63	178	170	0,99
250	80	195	170	1,08
250	100	215	170	1,19
250	112	225	170	1,24
250	125	240	170	1,31
250	140	260	175	1,45
250	150	270	175	1,50
250	160	280	175	1,55
250	180	300	175	1,65
250	200	335	190	1,95
250	224	360	190	1,98
280	80	195	185	1,20
280	100	215	185	1,31
280	112	225	185	1,37
280	125	240	185	1,46
280	140	260	190	1,59
280	150	270	190	1,65
280	160	280	190	1,71
280	180	300	190	1,81
280	200	335	205	2,08
280	224	360	205	2,19
280	250	385	205	2,57
300	80	195	195	1,29
300	100	215	195	1,38
300	112	225	195	1,47
300	125	240	195	1,53

Ød ₁ nom	Ød ₃ /Ød ₄ nom	l mm	l ₃ mm	m kg
300	140	260	200	1,66
300	150	270	200	1,76
300	160	280	200	1,82
300	180	300	200	1,93
300	200	335	215	2,27
300	224	360	215	2,34
300	250	385	215	2,75
300	280	425	225	2,95
315	80	205	205	1,31
315	100	225	205	1,44
315	112	235	205	1,49
315	125	250	205	1,59
315	140	270	210	1,81
315	150	280	210	1,90
315	160	290	210	1,91
315	180	310	210	2,13
315	200	345	225	2,35
315	224	370	225	2,61
315	250	395	225	2,97
315	280	435	235	3,26
315	300	455	235	3,26
355	100	225	250	1,74
355	112	235	250	1,85
355	125	250	250	2,03
355	140	270	230	2,29
355	150	280	230	2,40
355	160	290	230	2,50
355	180	310	230	2,71
355	200	345	245	3,15
355	224	370	245	3,37
355	250	395	245	3,96
355	280	435	245	4,33
355	300	455	255	4,43
355	315	470	255	4,48
400	100	225	245	1,99
400	112	235	245	2,05
400	125	250	245	2,24
400	140	270	250	2,47
400	150	280	250	2,60
400	160	290	250	2,72
400	180	310	250	2,95
400	200	345	265	3,35
400	224	370	265	3,71
400	250	395	265	4,37
400	280	435	275	4,68
400	300	455	275	4,97
400	315	470	275	4,99
400	355	520	285	5,42

- 1
- 2
- 3**
- 4
- 5
- 6
- 7
- 8
- 9
- 10
- 11
- 12
- 13
- 14
- 15
- 16
- 17
- 18

Ød_1 nom	$\text{Ød}_3/\text{Ød}_4$ nom	l mm	l ₃ mm	m kg
450	125	250	270	2,30
450	140	270	275	2,62
450	150	280	275	2,76
450	160	290	275	2,90
450	180	310	275	3,17
450	200	345	290	3,75
450	224	370	290	4,06
450	250	395	290	4,79
450	280	435	300	5,33
450	300	455	300	5,54
450	315	470	300	5,68
450	355	520	310	6,19
450	400	565	310	6,96
500	125	250	295	2,65
500	140	270	300	2,91
500	150	280	300	3,04
500	160	290	300	3,14
500	180	310	300	3,35
500	200	345	315	4,05
500	224	370	315	4,12
500	250	395	315	4,99
500	280	435	325	5,42
500	300	455	325	5,64
500	315	470	325	5,80
500	355	520	335	6,45
500	400	565	335	6,81
500	450	615	335	7,86
560	200	345	345	4,30
560	224	370	345	4,59
560	250	395	345	5,41
560	280	435	355	6,01
560	300	455	355	6,25
560	315	470	355	6,43
560	355	520	365	7,15
560	400	565	365	8,28
560	450	615	365	8,82
560	500	670	370	9,35
600	200	345	365	4,59
600	224	370	365	4,89
600	250	395	365	5,75
600	280	435	375	6,38
600	300	455	375	6,64
600	315	470	375	6,83
600	355	520	385	7,59
600	400	565	385	8,78
600	450	615	385	9,38
600	500	670	390	10,0
600	560	730	390	10,4

Ød_1 nom	$\text{Ød}_3/\text{Ød}_4$ nom	l mm	l ₃ mm	m kg
630	200	355	380	4,81
630	224	380	380	5,12
630	250	405	380	6,01
630	280	445	390	6,67
630	300	465	390	6,93
630	315	480	390	7,13
630	355	530	400	7,74
630	400	575	400	9,36
630	450	625	400	9,78
630	500	680	405	10,7
630	560	740	405	11,0
630	600	780	405	11,1
710	250	455	420	6,78
710	280	495	420	7,52
710	300	515	430	7,82
710	315	530	430	8,05
710	355	580	440	8,91
710	400	625	440	10,4
710	450	675	440	11,1
710	500	730	445	12,0
710	560	790	445	12,7
710	600	830	445	13,2
710	630	860	445	13,4
800	250	455	465	7,08
800	280	495	475	8,10
800	300	515	475	8,42
800	315	530	475	8,54
800	355	580	485	9,60
800	400	625	485	11,1
800	450	675	485	11,9
800	500	730	490	13,3
800	560	790	490	13,7
800	600	830	490	14,2
800	630	860	490	15,2
800	710	940	490	16,3
900	315	530	525	11,9
900	355	580	535	13,2
900	400	625	535	16,0
900	450	675	535	16,5
900	500	730	540	17,9
900	560	790	540	19,2
900	600	830	540	20,1
900	630	860	540	20,7
900	710	940	540	23,7
900	800	1030	540	25,1
1000	315	530	575	13,0
1000	355	580	585	14,3
1000	400	625	585	16,6

X-piece

$\varnothing d_1$ nom	$\varnothing d_3/\varnothing d_4$ nom	l mm	l ₃ mm	m kg
1000	450	675	585	17,9
1000	500	730	590	19,0
1000	560	790	590	21,0
1000	600	830	590	22,1
1000	630	860	590	23,4
1000	710	940	590	26,4
1000	800	1030	590	28,5
1000	900	1150	590	31,0
1120	500	730	650	21,4
1120	560	790	650	23,1
1120	600	830	650	24,3
1120	630	860	650	25,2
1120	710	940	650	29,1
1120	800	1030	650	31,7
1120	900	1150	650	35,4
1120	1000	1250	650	37,3
1250	500	730	715	23,4
1250	560	790	715	25,3
1250	600	830	715	26,6
1250	630	860	715	27,6
1250	710	940	715	31,9
1250	800	1030	715	34,9
1250	900	1150	715	39,1
1250	1000	1250	715	41,9
1250	1120	1370	715	47,1

1
2
3
4
5
6
7
8
9
10
11
12
13
14
15
16
17
18



Dimensions

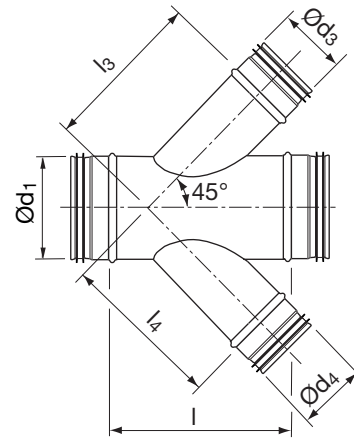

Description

As standard is $\text{Ød}_3 = \text{Ød}_4$ and the angle 45° .
Different dimensions and angle available to order.

Ød_1 nom	$\text{Ød}_3/\text{Ød}_4$ nom	l mm	l_3/l_4 mm	m kg
80	80	250	165	0,80
100	80	250	180	0,90
100	100	280	190	1,10
125	80	250	200	1,00
125	100	280	210	1,30
125	112	295	215	1,40
125	125	315	220	1,50
140	80	280	210	1,10
140	100	305	220	1,40
140	112	320	225	1,50
140	125	340	230	1,60
140	140	365	250	1,90
150	80	280	215	1,20
150	100	305	225	1,50
150	112	320	235	1,60
150	125	340	240	1,70
150	140	365	260	2,00
150	150	380	265	2,10
160	80	280	220	1,20
160	100	305	230	1,50
160	112	320	240	1,60
160	125	340	245	1,70
160	140	365	265	2,00
160	150	380	270	2,10
160	160	390	275	2,20
180	80	280	235	1,30
180	100	305	245	1,60
180	112	320	250	1,70
180	125	340	260	1,80
180	140	365	280	2,20
180	150	380	285	2,30
180	160	390	290	2,40
180	180	420	300	2,70

Ordering example

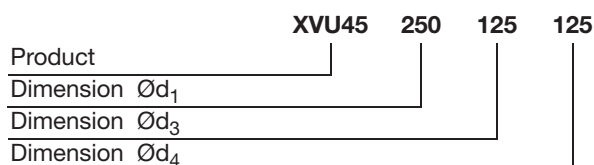

X-piece

Ød ₁ nom	Ød ₃ /Ød ₄ nom	l mm	l ₃ /l ₄ mm	m kg
200	80	280	250	1,40
200	100	305	260	1,70
200	112	320	265	1,80
200	125	340	270	2,00
200	140	365	295	2,30
200	150	380	300	2,40
200	160	390	305	2,50
200	180	420	315	2,90
200	200	450	325	3,30
224	100	305	275	1,90
224	112	320	285	2,00
224	125	340	290	2,10
224	140	365	310	2,50
224	150	380	315	2,60
224	160	390	320	2,70
224	180	420	330	3,10
224	200	450	340	3,50
224	224	480	350	3,80
250	100	305	295	2,30
250	112	320	300	2,40
250	125	340	310	2,50
250	140	365	330	2,90
250	150	380	335	3,10
250	160	390	340	3,20
250	180	420	350	3,40
250	200	450	360	3,90
250	224	480	370	4,20
250	250	520	385	4,80
280	112	320	320	2,70
280	125	340	330	2,90
280	140	365	350	3,20
280	150	380	355	3,30
280	160	390	360	3,40
280	180	445	370	3,80
280	200	475	380	4,30
280	224	510	390	4,60
280	250	545	405	5,20
280	280	590	435	5,90
300	125	340	350	3,30
300	140	365	365	3,70
300	150	380	370	3,90
300	160	390	375	4,00
300	180	445	385	4,40
300	200	475	395	4,90
300	224	510	405	5,30
300	250	545	420	5,90
300	280	590	450	6,70
300	300	615	460	7,60

Ød ₁ nom	Ød ₃ /Ød ₄ nom	l mm	l ₃ /l ₄ mm	m kg
315	140	365	375	4,10
315	150	380	380	4,30
315	160	395	385	4,40
315	180	445	395	4,80
315	200	475	405	5,40
315	224	510	415	5,80
315	250	545	430	6,50
315	280	590	460	7,30
315	300	615	470	7,90
315	315	640	480	8,30
355	150	380	410	4,70
355	160	395	415	4,80
355	180	445	425	5,20
355	200	475	435	5,90
355	224	510	445	6,20
355	250	545	460	7,00
355	280	590	490	7,90
355	300	615	500	8,40
355	315	640	505	8,80
355	355	695	525	10,0
400	160	395	445	5,60
400	180	445	455	6,00
400	200	475	465	6,70
400	224	510	475	7,10
400	250	545	490	7,80
400	280	590	520	8,80
400	300	615	530	9,40
400	315	640	535	9,80
400	355	695	555	11,0
400	400	760	580	12,7
450	180	445	490	6,70
450	200	475	500	7,40
450	224	510	510	7,80
450	250	545	525	8,60
450	280	590	555	9,50
450	300	615	565	10,1
450	315	640	570	10,6
450	355	695	590	11,8
450	400	760	615	13,6
450	450	830	640	15,5
500	200	475	535	8,00
500	224	510	550	8,40
500	250	545	560	9,30
500	280	590	590	10,3
500	300	615	600	10,9
500	315	640	610	11,4
500	355	695	630	12,7
500	400	760	650	14,5

- 1
- 2
- 3**
- 4
- 5
- 6
- 7
- 8
- 9
- 10
- 11
- 12
- 13
- 14
- 15
- 16
- 17
- 18

1

2

3

4

5

6

7

8

9

10

11

12

13

14

15

16

17

18

Ød ₁ nom	Ød ₃ /Ød ₄ nom	l mm	l ₃ /l ₄ mm	m kg
500	450	830	675	16,5
500	500	900	700	18,6
560	224	510	590	9,80
560	250	600	605	10,7
560	280	640	630	11,6
560	300	665	640	12,3
560	315	690	650	12,6
560	355	750	670	14,2
560	400	810	690	16,0
560	450	880	715	18,1
560	500	950	740	20,3
560	560	1040	800	23,4
600	250	600	630	12,2
600	280	640	655	13,3
600	300	665	665	14,0
600	315	690	675	14,6
600	355	750	695	16,3
600	400	810	715	18,2
600	450	880	740	20,4
600	500	950	765	23,0
600	560	1040	825	26,4
600	600	1090	850	29,3
630	280	640	680	14,8
630	300	665	690	15,6
630	315	690	700	16,1
630	355	750	720	18,0
630	400	810	740	20,2
630	450	880	765	22,6
630	500	950	790	25,2
630	560	1040	850	28,8
630	600	1090	870	31,3
630	630	1140	885	33,4
710	300	665	745	17,8
710	315	690	755	18,4
710	355	750	775	20,3
710	400	810	800	22,5
710	450	880	825	25,2
710	500	950	850	27,9
710	560	1040	905	31,6
710	600	1090	925	34,1
710	630	1140	940	36,4
710	710	1250	980	41,7
800	315	690	820	20,2
800	355	750	840	22,2
800	400	810	860	24,6
800	450	880	885	27,4
800	500	950	910	30,2
800	560	1040	970	34,2

Ød ₁ nom	Ød ₃ /Ød ₄ nom	l mm	l ₃ /l ₄ mm	m kg
800	600	1090	990	37,4
800	630	1140	1005	39,1
800	710	1250	1045	44,6
800	800	1380	1090	51,0
900	355	750	910	27,4
900	400	810	935	30,3
900	450	880	960	33,5
900	500	950	985	36,9
900	560	1040	1040	41,6
900	600	1090	1060	44,6
900	630	1140	1075	47,3
900	710	1250	1115	53,7
900	800	1380	1160	51,2
900	900	1520	1210	69,7
1000	400	810	1005	33,0
1000	450	880	1030	36,4
1000	500	950	1055	40,0
1000	560	1040	1110	44,8
1000	600	1090	1130	48,0
1000	630	1140	1145	50,7
1000	710	1250	1185	57,5
1000	800	1380	1230	65,3
1000	900	1520	1280	74,2
1000	1000	1660	1330	83,5
1120	500	1005	1140	51,0
1120	560	1090	1195	57,3
1120	600	1140	1215	60,9
1120	630	1190	1230	64,2
1120	710	1305	1270	72,1
1120	800	1430	1315	81,2
1120	900	1570	1365	91,6
1120	1000	1710	1415	102
1120	1120	1880	1505	118
1250	500	1005	1230	56,1
1250	560	1090	1290	62,3
1250	600	1140	1310	66,3
1250	630	1190	1325	69,6
1250	710	1305	1365	78,0
1250	800	1430	1410	87,5
1250	900	1570	1460	98,5
1250	1000	1710	1510	110
1250	1120	1880	1595	126
1250	1250	2065	1660	142



Description

As standard is $\text{Ø}d_3 = \text{Ø}d_4$ and the angle 45° .
Different dimensions and angle available to order.

....

Dimensions

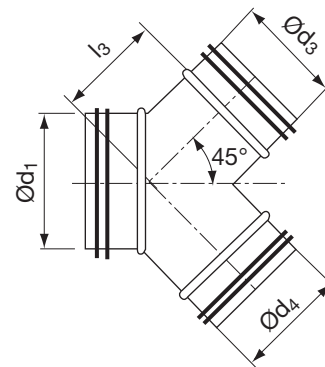

$\text{Ø}d_1$ nom	$\text{Ø}d_3$ nom	$\text{Ø}d_4$ nom	l_3 mm	m kg
80	80	80	120	0,90
100	80	80	140	1,00
100	100	100	140	1,00
112	80	80	160	1,00
125	100	100	170	1,30
125	125	125	170	1,30
140	100	100	185	1,40
150	100	100	190	1,50
150	150	150	190	1,50
160	112	112	205	1,60
160	160	160	205	1,80
180	125	125	215	1,80
180	180	180	215	1,80
200	140	140	230	2,10
200	200	200	230	2,10
224	160	160	250	3,50
224	224	224	250	2,70
250	180	180	280	3,50
250	200	200	280	3,50
250	250	250	280	3,50
280	200	200	310	3,60
280	280	280	310	3,50
300	200	200	320	4,20
300	300	300	320	4,20
315	224	224	335	4,40
315	315	315	335	4,80
355	250	250	365	5,00
355	355	355	365	6,40
400	280	280	410	6,80
400	300	300	410	7,00
400	400	400	410	9,10
450	300	300	440	8,50
450	315	315	440	8,50

Ordering example

Product	YVU45	125	100	100
Dimension $\text{Ø}d_1$				
Dimension $\text{Ø}d_3$				
Dimension $\text{Ø}d_4$				

- 1
- 2
- 3**
- 4
- 5
- 6
- 7
- 8
- 9
- 10
- 11
- 12
- 13
- 14
- 15
- 16
- 17
- 18

Ød_1 nom	Ød_3 nom	Ød_4 nom	l_3 mm	m kg
500	355	355	490	9,80
560	400	400	550	12,1
600	400	400	580	13,2
630	450	450	610	15,6
630	630	630	610	20,6
710	500	500	670	18,7
710	710	710	670	24,4
800	560	560	740	22,7
800	800	800	740	28,9
900	630	630	825	24,8
1000	710	710	920	30,5
1120	800	800	1030	38,0
1250	900	900	1150	50,0



Description

Hand made centric T-piece.

Dimensions

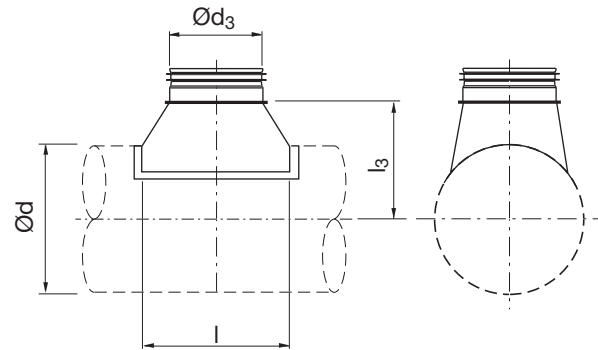

Ød nom	Ød ₃ nom	l mm	l ₃ mm	m kg
63	80	145	77	0,15
63	100	165	77	0,20
80	100	165	85	0,21
80	112	175	85	0,24
80	125	190	85	0,29
100	112	175	95	0,22
100	125	190	95	0,25
100	140	210	100	0,30
100	150	220	100	0,30
100	160	230	100	0,36
112	112	175	100	0,27
112	125	190	100	0,30
112	140	210	105	0,34
112	150	220	105	0,37
112	160	230	105	0,39
112	180	250	105	0,43
125	112	175	110	0,23
125	140	210	115	0,31
125	150	220	115	0,33
125	160	230	115	0,35
125	180	250	115	0,41
125	200	285	130	0,50
140	80	145	115	0,22
140	112	175	115	0,28
140	150	220	120	0,38
140	160	230	120	0,40
140	180	250	120	0,45
140	200	285	135	0,53
140	224	310	135	0,59
150	80	145	120	0,19
150	112	175	120	0,27
150	160	230	125	0,43
150	180	250	125	0,47

Ordering example

Product	TSTCU	400	500
Dimension Ød			
Dimension Ød ₃			

Ød nom	Ød ₃ nom	l mm	l ₃ mm	m kg
150	200	285	140	0,57
150	224	310	140	0,64
150	250	335	140	0,77
160	63	128	125	0,10
160	112	175	125	0,25
160	180	250	130	0,47
160	200	285	145	0,57
160	224	310	145	0,65
160	250	335	145	0,85
180	63	128	135	0,16
180	80	145	135	0,20
180	112	175	135	0,27
180	125	190	135	0,31
180	140	210	140	0,36
180	150	220	140	0,39
180	160	230	140	0,43
180	200	285	155	0,62
180	224	310	155	0,69
180	250	335	155	0,82
180	280	375	165	1,02
200	63	128	145	0,14
200	112	175	145	0,25
200	224	310	165	0,66
200	250	335	165	0,79
200	280	375	175	1,00
200	300	395	175	1,09
200	315	410	175	1,13
224	63	128	160	0,15
224	112	175	160	0,25
224	250	335	180	0,84
224	280	375	190	1,01
224	300	395	190	1,11
224	315	410	190	1,18
224	355	460	200	1,44
250	63	128	170	0,15
250	112	175	170	0,26
250	280	375	200	1,03
250	300	395	200	1,12
250	315	410	200	1,13
250	355	460	210	1,46
250	400	505	210	1,83
280	112	175	185	0,27
280	250	335	205	0,86
280	280	375	215	1,03
280	300	395	215	1,12
280	315	410	215	1,19
280	355	460	225	1,44
280	400	505	225	1,80

Ød nom	Ød ₃ nom	l mm	l ₃ mm	m kg
280	450	555	225	2,11
300	112	175	195	0,28
300	280	375	225	1,03
300	315	410	225	1,20
300	355	460	235	1,45
300	400	505	235	1,73
300	450	555	235	2,10
315	112	175	205	0,26
315	280	375	235	1,11
315	355	460	245	1,53
315	400	505	245	1,80
315	450	555	245	2,01
315	500	610	250	2,24
355	112	175	225	0,28
355	280	375	245	1,36
355	315	410	255	1,55
355	355	460	265	1,91
355	400	505	265	2,18
355	450	555	265	2,46
355	500	610	270	2,77
355	560	670	270	3,11
400	112	175	245	0,28
400	140	210	250	0,44
400	180	250	250	0,66
400	280	375	275	1,34
400	355	460	285	1,89
400	450	555	285	2,58
400	500	610	290	2,96
400	560	670	290	3,29
400	600	710	290	3,51
400	630	740	290	3,68
450	140	210	275	0,40
450	180	250	275	0,64
450	280	375	300	1,46
450	355	460	310	1,98
450	450	555	310	2,60
450	500	610	315	3,08
450	560	670	315	3,48
450	600	710	315	3,74
450	630	740	315	3,94
450	710	820	315	4,70
500	140	210	300	0,43
500	180	250	300	0,60
500	280	375	325	1,29
500	355	460	335	1,85
500	450	555	335	2,74
500	500	610	340	3,28
500	560	670	340	3,83

T-piece

Ød nom	Ød ₃ nom	l mm	l ₃ mm	m kg
500	600	710	340	4,25
500	630	740	340	4,35
500	710	820	340	5,74
500	800	910	340	6,91
560	280	375	355	1,34
560	355	460	365	1,98
560	450	555	365	2,78
560	500	610	370	3,27
560	560	670	370	3,85
560	600	710	370	4,26
560	630	740	370	4,58
560	710	820	370	5,71
560	800	910	370	6,34
560	900	1030	370	8,45
600	280	375	375	1,37
600	355	460	385	1,93
600	450	555	385	2,81
600	500	610	390	3,29
600	560	670	390	3,86
600	600	710	390	4,54
600	630	740	390	4,58
600	710	820	390	5,69
600	800	910	390	6,79
600	900	1030	390	8,36
630	280	375	390	1,39
630	355	460	400	1,86
630	450	555	400	2,83
630	500	610	405	3,42
630	560	670	405	3,87
630	600	710	405	4,27
630	630	740	405	4,45
630	710	820	405	5,68
630	800	910	405	6,76
630	900	1030	405	8,30
630	1000	1130	405	9,71
710	250	335	420	1,26
710	280	375	420	1,50
710	300	395	430	1,64
710	315	410	430	1,74
710	355	460	440	2,08
710	400	505	440	2,61
710	450	555	440	3,01
710	500	610	445	3,52
710	560	670	445	4,11
710	600	710	445	4,52
710	630	740	445	4,81
710	710	820	445	6,00
710	800	910	445	7,10

Ød nom	Ød ₃ nom	l mm	l ₃ mm	m kg
710	900	1030	445	8,69
710	1000	1130	445	10,2
710	1120	1250	445	12,4
800	250	335	465	1,08
800	280	375	475	1,44
800	300	395	475	1,57
800	315	410	475	1,61
800	355	460	485	2,00
800	400	505	485	2,50
800	450	555	485	2,88
800	500	610	490	3,59
800	560	670	490	3,93
800	600	710	490	4,32
800	630	740	490	4,94
800	710	820	490	5,73
800	800	910	490	6,99
800	900	1030	490	8,32
800	1000	1130	490	8,61
800	1120	1250	490	11,9
800	1250	1380	490	14,0
900	315	410	525	2,00
900	355	460	535	2,43
900	400	505	535	3,41
900	450	555	535	3,59
900	500	610	540	4,24
900	560	670	540	5,01
900	600	710	540	5,56
900	630	740	540	5,99
900	710	820	540	7,50
900	800	910	540	9,03
900	900	1030	540	11,2
900	1000	1130	540	13,3
900	1120	1250	540	16,4
900	1250	1380	540	19,7
1000	315	410	575	1,95
1000	355	460	585	2,36
1000	400	505	585	2,97
1000	450	555	585	3,54
1000	500	610	590	3,99
1000	560	670	590	5,02
1000	600	710	590	5,66
1000	630	740	590	6,34
1000	710	820	590	7,67
1000	800	910	590	9,31
1000	900	1030	590	11,8
1000	1000	1130	590	14,2
1000	1120	1250	590	17,7
1000	1250	1380	590	21,5

$\varnothing d$ nom	$\varnothing d_3$ nom	l mm	l_3 mm	m kg
1120	500	610	650	4,25
1120	560	670	650	5,07
1120	600	710	650	5,66
1120	630	740	650	6,12
1120	710	820	650	7,75
1120	800	910	650	9,45
1120	900	1030	650	12,2
1120	1000	1130	650	14,3
1120	1120	1250	650	17,9
1120	1250	1380	650	21,7
1250	500	610	715	4,28
1250	560	670	715	5,11
1250	600	710	715	5,71
1250	630	740	715	6,18
1250	710	820	715	7,83
1250	800	910	715	9,55
1250	900	1030	715	12,5
1250	1000	1130	715	14,5
1250	1120	1250	715	18,2
1250	1250	1380	715	22,0



Description

Hand made tangential T-piece.

Dimensions

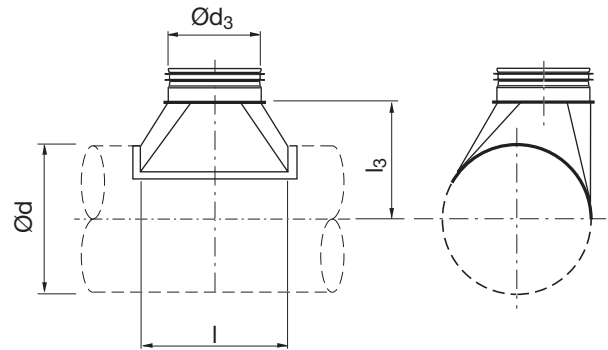

Ød nom	Ød ₃ nom	l mm	l ₃ mm	m kg
63	80	145	77	0,15
63	100	165	77	0,20
80	63	128	85	0,12
80	100	165	85	0,21
80	112	175	85	0,24
80	125	190	85	0,29
100	63	128	95	0,13
100	80	145	95	0,16
100	112	175	95	0,22
100	125	190	95	0,25
100	140	210	100	0,30
100	150	220	100	0,30
100	160	230	100	0,36
112	63	128	100	0,18
112	80	145	100	0,21
112	100	165	100	0,25
112	125	190	100	0,30
112	140	210	105	0,34
112	150	220	105	0,37
112	160	230	105	0,39
112	180	250	105	0,43
125	63	128	110	0,14
125	80	145	110	0,17
125	100	165	110	0,21
125	112	175	110	0,23
125	140	210	115	0,31
125	150	220	115	0,33
125	160	230	115	0,35
125	180	250	115	0,41
125	200	285	130	0,50
140	63	128	115	0,18
140	80	145	115	0,22
140	100	165	115	0,26

Ordering example

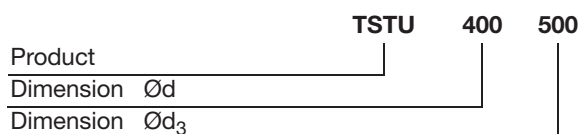

1
2
3
4
5
6
7
8
9
10
11
12
13
14
15
16
17
18

Ød nom	Ød ₃ nom	l mm	l ₃ mm	m kg
140	112	175	115	0,28
140	125	190	115	0,31
140	150	220	120	0,38
140	160	230	120	0,40
140	180	250	120	0,45
140	200	285	135	0,53
140	224	310	135	0,59
150	63	128	120	0,14
150	80	145	120	0,19
150	100	165	120	0,24
150	112	175	120	0,27
150	125	190	120	0,31
150	140	210	125	0,37
150	160	230	125	0,43
150	180	250	125	0,47
150	200	285	140	0,57
150	224	310	140	0,64
150	250	335	140	0,77
160	63	128	125	0,10
160	80	145	125	0,15
160	100	165	125	0,22
160	112	175	125	0,25
160	125	190	125	0,29
160	140	210	130	0,35
160	150	220	130	0,38
160	180	250	130	0,47
160	200	285	145	0,57
160	224	310	145	0,65
160	250	335	145	0,85
180	63	128	135	0,16
180	80	145	135	0,20
180	100	165	135	0,25
180	112	175	135	0,27
180	125	190	135	0,31
180	140	210	140	0,36
180	150	220	140	0,39
180	160	230	140	0,43
180	200	285	155	0,62
180	224	310	155	0,69
180	250	335	155	0,82
180	280	375	165	1,02
200	63	128	145	0,14
200	80	145	145	0,18
200	100	165	145	0,23
200	112	175	145	0,25
200	125	190	145	0,29
200	140	210	150	0,34
200	150	220	150	0,37

Ød nom	Ød ₃ nom	l mm	l ₃ mm	m kg
200	160	230	150	0,40
200	180	250	150	0,46
200	224	310	165	0,66
200	250	335	165	0,79
200	280	375	175	1,00
200	300	395	175	1,09
200	315	410	175	1,13
224	63	128	160	0,15
224	80	145	160	0,18
224	100	165	160	0,23
224	112	175	160	0,25
224	125	190	160	0,29
224	140	210	165	0,35
224	150	220	165	0,37
224	160	230	165	0,40
224	180	250	165	0,47
224	200	285	180	0,63
224	250	335	180	0,84
224	280	375	190	1,01
224	300	395	190	1,11
224	315	410	190	1,18
224	355	460	200	1,44
250	63	128	170	0,15
250	80	145	170	0,18
250	100	165	170	0,23
250	112	175	170	0,26
250	125	190	170	0,29
250	140	210	175	0,35
250	150	220	175	0,38
250	160	230	175	0,41
250	180	250	175	0,47
250	200	285	190	0,62
250	224	310	190	0,68
250	280	375	200	1,03
250	300	395	200	1,12
250	315	410	200	1,13
250	355	460	210	1,46
250	400	505	210	1,83
280	80	145	185	0,20
280	100	165	185	0,24
280	112	175	185	0,27
280	125	190	185	0,31
280	140	210	190	0,36
280	150	220	190	0,39
280	160	230	190	0,42
280	180	250	190	0,49
280	200	285	205	0,60
280	224	310	205	0,69

T-piece

Ød nom	Ød ₃ nom	l mm	l ₃ mm	m kg
280	250	335	205	0,86
280	300	395	215	1,12
280	315	410	215	1,19
280	355	460	225	1,44
280	400	505	225	1,80
280	450	555	225	2,11
300	80	145	195	0,20
300	100	165	195	0,24
300	112	175	195	0,28
300	125	190	195	0,30
300	140	210	200	0,35
300	150	220	200	0,40
300	160	230	200	0,43
300	180	250	200	0,49
300	200	285	215	0,63
300	224	310	215	0,70
300	250	335	215	0,86
300	280	375	225	1,03
300	315	410	225	1,20
300	355	460	235	1,45
300	400	505	235	1,73
300	450	555	235	2,10
315	80	145	205	0,19
315	100	165	205	0,24
315	112	175	205	0,26
315	125	190	205	0,31
315	140	210	210	0,40
315	150	220	210	0,44
315	160	230	210	0,45
315	180	250	210	0,56
315	200	285	225	0,63
315	224	310	225	0,79
315	250	335	225	0,92
315	280	375	235	1,11
315	300	395	235	1,19
315	355	460	245	1,53
315	400	505	245	1,80
315	450	555	245	2,01
315	500	610	250	2,24
355	100	165	225	0,23
355	112	175	225	0,28
355	125	195	225	0,36
355	140	210	230	0,45
355	150	220	230	0,50
355	160	230	230	0,55
355	180	250	230	0,65
355	200	285	245	0,82
355	224	310	245	0,95

Ød nom	Ød ₃ nom	l mm	l ₃ mm	m kg
355	250	335	245	1,16
355	280	375	245	1,36
355	300	395	255	1,47
355	315	410	255	1,55
355	400	505	265	2,18
355	450	555	265	2,46
355	500	610	270	2,77
355	560	670	270	3,11
400	100	165	245	0,26
400	112	175	245	0,28
400	125	195	245	0,36
400	140	210	250	0,44
400	150	220	250	0,50
400	160	230	250	0,55
400	180	250	250	0,66
400	200	285	265	0,78
400	224	310	265	0,97
400	250	335	265	1,19
400	280	375	275	1,34
400	300	395	275	1,52
400	315	410	275	1,56
400	355	460	285	1,89
400	450	555	285	2,58
400	500	610	290	2,96
400	560	670	290	3,29
400	600	710	290	3,51
400	630	740	290	3,68
450	125	190	270	0,28
450	140	210	275	0,40
450	150	220	275	0,46
450	160	230	275	0,52
450	180	250	275	0,64
450	200	285	290	0,84
450	224	310	290	0,98
450	250	335	290	1,22
450	280	375	300	1,46
450	300	395	300	1,58
450	315	410	300	1,68
450	355	460	310	1,98
450	400	505	310	2,39
450	500	610	315	3,08
450	560	670	315	3,48
450	600	710	315	3,74
450	630	740	315	3,94
450	710	820	315	4,70
500	125	190	295	0,35
500	140	210	300	0,43
500	150	220	300	0,48

- 1
- 2
- 3**
- 4
- 5
- 6
- 7
- 8
- 9
- 10
- 11
- 12
- 13
- 14
- 15
- 16
- 17
- 18

Ød nom	Ød ₃ nom	l mm	l ₃ mm	m kg
500	160	230	300	0,52
500	180	250	300	0,60
500	200	285	315	0,84
500	224	310	315	0,86
500	250	335	315	1,13
500	280	375	325	1,29
500	300	395	325	1,42
500	315	410	325	1,52
500	355	460	335	1,85
500	400	505	335	2,26
500	450	555	335	2,74
500	560	670	340	3,83
500	600	710	340	4,25
500	630	740	340	4,35
500	710	820	340	5,74
500	800	910	340	6,91
560	200	285	345	0,78
560	224	310	345	0,90
560	250	335	345	1,12
560	280	375	355	1,34
560	300	395	355	1,47
560	315	410	355	1,57
560	355	460	365	1,98
560	400	505	365	2,38
560	450	555	365	2,78
560	500	610	370	3,27
560	600	710	370	4,26
560	630	740	370	4,58
560	710	820	370	5,71
560	800	910	370	6,34
560	900	1030	370	8,45
600	200	285	365	0,81
600	224	310	365	0,93
600	250	335	365	1,14
600	280	375	375	1,37
600	300	395	375	1,50
600	315	410	375	1,59
600	355	460	385	1,93
600	400	505	385	2,39
600	450	555	385	2,81
600	500	610	390	3,29
600	560	670	390	3,86
600	630	740	390	4,58
600	710	820	390	5,69
600	800	910	390	6,79
600	900	1030	390	8,36
630	200	285	380	0,83
630	224	310	380	0,95

Ød nom	Ød ₃ nom	l mm	l ₃ mm	m kg
630	250	335	380	1,16
630	280	375	390	1,39
630	300	395	390	1,52
630	315	410	390	1,62
630	355	460	400	1,86
630	400	505	400	2,51
630	450	555	400	2,83
630	500	610	405	3,42
630	560	670	405	3,87
630	600	710	405	4,27
630	710	820	405	5,68
630	800	910	405	6,76
630	900	1030	405	8,30
630	1000	1130	405	9,71
710	250	335	420	1,26
710	280	375	420	1,50
710	300	395	430	1,64
710	315	410	430	1,74
710	355	460	440	2,08
710	400	505	440	2,61
710	450	555	440	3,01
710	500	610	445	3,52
710	560	670	445	4,11
710	600	710	445	4,52
710	630	740	445	4,81
710	800	910	445	7,10
710	900	1030	445	8,69
710	1000	1130	445	10,2
710	1120	1250	445	12,4
800	250	335	465	1,08
800	280	375	475	1,44
800	300	395	475	1,57
800	315	410	475	1,61
800	355	460	485	2,00
800	400	505	485	2,50
800	450	555	485	2,88
800	500	610	490	3,59
800	560	670	490	3,93
800	600	710	490	4,32
800	630	740	490	4,94
800	710	820	490	5,73
800	900	1030	490	8,32
800	1000	1130	490	8,61
800	1120	1250	490	11,9
800	1250	1380	490	14,0
900	315	410	525	2,00
900	355	460	535	2,43
900	400	505	535	3,41

T-piece

Ød nom	Ød ₃ nom	l mm	l ₃ mm	m kg
900	450	555	535	3,59
900	500	610	540	4,24
900	560	670	540	5,01
900	600	710	540	5,56
900	630	740	540	5,99
900	710	820	540	7,50
900	800	910	540	9,03
900	1000	1130	540	13,3
900	1120	1250	540	16,4
900	1250	1380	540	19,7
1000	315	410	575	1,95
1000	355	460	585	2,36
1000	400	505	585	2,97
1000	450	555	585	3,54
1000	500	610	590	3,99
1000	560	670	590	5,02
1000	600	710	590	5,66
1000	630	740	590	6,34
1000	710	820	590	7,67
1000	800	910	590	9,31
1000	900	1030	590	11,8
1000	1120	1250	590	17,7
1000	1250	1380	590	21,5
1120	500	610	650	4,25
1120	560	670	650	5,07
1120	600	710	650	5,66
1120	630	740	650	6,12
1120	710	820	650	7,75
1120	800	910	650	9,45
1120	900	1030	650	12,2
1120	1000	1130	650	14,3
1120	1250	1380	650	21,7
1250	500	610	715	4,28
1250	560	670	715	5,11
1250	600	710	715	5,71
1250	630	740	715	6,18
1250	710	820	715	7,83
1250	800	910	715	9,55
1250	900	1030	715	12,5
1250	1000	1130	715	14,5
1250	1120	1250	715	18,2

1

2

3

4

5

6

7

8

9

10

11

12

13

14

15

16

17

18

1

2

3

4

5



6

Description

Take-off with radius.

7

8

9

10

11

12

13

14

15

16

Ordering example

ILRU 250

Product

Dimension $\text{\O}d_1$

17

18

Dimensions

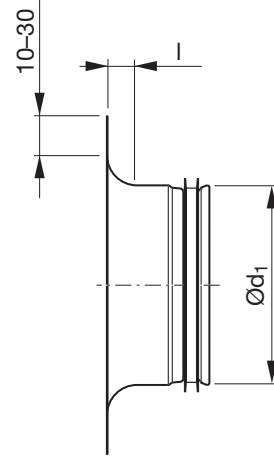

$\text{\O}d_1$ nom	l mm	m kg
63	10	0,07
80	12	0,10
100	15	0,11
125	20	0,14
140	20	0,22
150	20	0,24
160	25	0,19
180	25	0,30
200	25	0,26
224	25	0,46
250	25	0,57
300	25	0,68
315	25	0,72
355	25	0,53
400	25	0,97
500	25	1,35
630	25	1,77



Description

Take-off without radius.

Dimensions

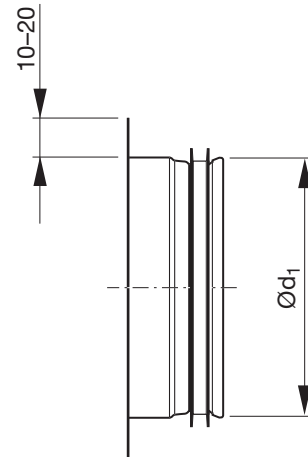

Ød ₁ nom	m kg
63	0,07
80	0,07
100	0,08
112	0,09
125	0,11
140	0,12
150	0,12
160	0,16
180	0,15
200	0,17
224	0,23
250	0,33
280	0,37
300	0,40
315	0,42
355	0,48
400	0,65
450	0,74
500	0,82
560	1,13
600	1,21
630	1,27
710	2,12
800	2,39
900	2,69
1000	3,57
1120	3,99
1250	4,46

Ordering example

Product **ILU**
 Dimension Ød₁ **250**

1

2

3

4

5

6

7

8

9

10

11

12

13

14

15

16

17

18

1

2

3

4

5

6

7

8

9

10

11

12

13

14

15

16

17

18



Description

Take-off without radius. With female end – fits outside a Safe fitting.

Hasn't any Click function – hasn't any notches.

Dimensions

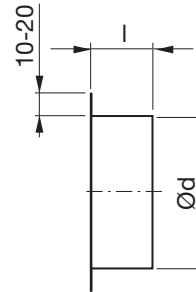

Ød nom	l mm	m kg
63	45	0,06
80	45	0,08
100	45	0,06
112	45	0,10
125	45	0,08
140	45	0,15
150	45	0,15
160	45	0,16
180	45	0,19
200	45	0,21
224	45	0,26
250	65	0,31
280	65	0,30
300	65	0,41
315	65	0,46
355	65	0,41
400	90	0,58
450	90	0,71
500	90	0,83
560	90	0,96
600	90	0,99
630	90	1,13
710	110	1,50
800	110	1,70
900	110	2,50
1000	135	3,35
1120	135	3,75
1250	135	4,20

Ordering example

Product **ILF**
Dimension Ød **200**



Description

To terminate an inlet duct.

With radius.

Mesh size 10 × 10 mm

Dimensions

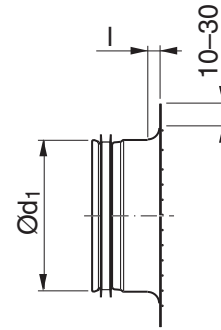

Ød ₁ nom	l mm	m kg
63	10	0,07
80	12	0,11
100	15	0,16
125	20	0,21
140	20	0,24
150	20	0,27
160	25	0,22
180	25	0,34
200	25	0,39
224	25	0,51
250	25	0,64
300	25	0,77
315	25	0,83
355	25	0,89
400	25	1,14
500	25	1,61
630	25	2,19

Ordering example

Product **ILRNU** **200**
 Dimension Ød₁

1

2

3

4

5



6

Description

To terminate an inlet duct.

Mesh size 10 × 10 mm.

7

8

9

10

11

12

13

14

15

16

Ordering example

Product **ESNU** **200**
 Dimension Ød_1

17

18

Dimensions

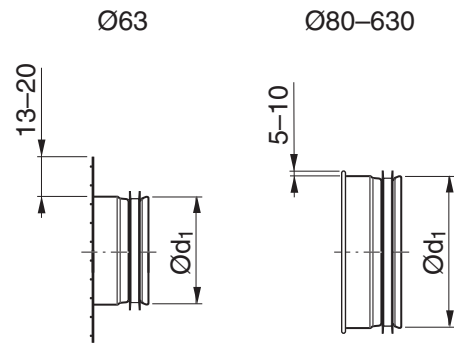

Ød_1 nom	m kg
63	0,06
80	0,08
100	0,10
112	0,11
125	0,13
140	0,15
150	0,16
160	0,17
180	0,21
200	0,25
224	0,31
250	0,38
280	0,44
300	0,51
315	0,57
355	0,66
400	0,75
450	0,92
500	1,09
560	1,32
600	1,48
630	1,55
710	1,82
800	2,11
900	2,57
1000	3,23
1120	3,59
1250	4,00



Description

To terminate an inlet duct. With female end – fits outside a Safe fitting.

Mesh size 10 × 10 mm.

No Click function – no notches.

Dimensions

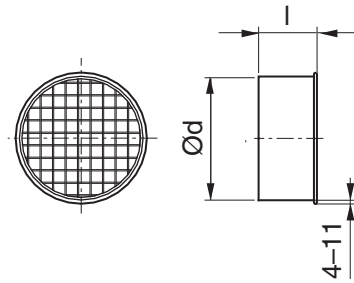

Ød nom	l mm	m kg
80	48	0,07
100	48	0,09
112	48	0,10
125	48	0,11
140	48	0,13
150	48	0,14
160	48	0,15
180	48	0,17
200	48	0,21
224	48	0,25
250	68	0,32
280	68	0,38
300	68	0,42
315	68	0,45
355	68	0,54
400	93	0,69
450	93	0,81
500	93	0,92
560	93	1,12
600	93	1,23
630	93	1,29
710	113	1,47
800	113	1,65
900	138	1,97
1000	138	2,50
1120	138	2,79
1250	138	3,08

Ordering example

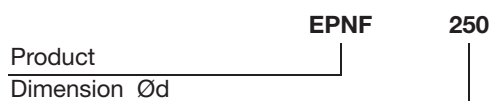

- 1
- 2
- 3
- 4
- 5
- 6
- 7
- 8
- 9
- 10
- 11
- 12
- 13
- 14
- 15
- 16
- 17
- 18

1

2

3

4

5



6

Description

To terminate an inlet duct.

Mesh size 10 × 10 mm.

7

8

9

10

11

12

13

14

15

16

Ordering example

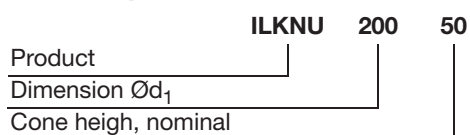

17

18

Dimensions

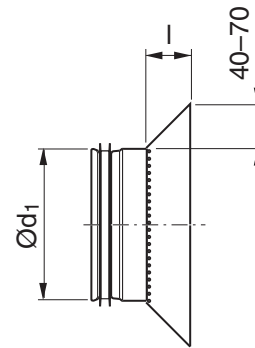

$\text{\O}d_1$ nom	l mm	m kg
80	50	0,12
100	50	0,15
125	50	0,22
160	50	0,25
200	50	0,32
250	53	0,65
315	68	0,89
400	50	1,00
500	50	1,24
630	40	1,43
800	50	1,79

Take-off with mesh and cone ILKNU 100



Description

To terminate an inlet duct.

Mesh size 10 × 10 mm.

Dimensions

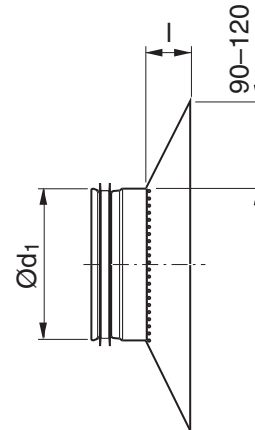

$\varnothing d_1$ nom	l mm	m kg
100	100	0,48
125	95	0,54
160	98	0,68
200	100	0,99
250	100	1,23
315	93	1,43
400	100	1,73
500	105	2,14
630	115	2,87
800	100	4,21

Ordering example

	ILKNU	200	100
Product			
Dimension $\varnothing d_1$			
Cone heigh, nominal			

1

2

3

4

5



6

Description

To terminate an inlet duct. With female end – fits outside a Safe fitting.

7

Mesh size 10 × 10 mm.

8

No Click function – no notches.

9

10

11

12

13

14

15

16

Ordering example

ILKNF 200 50

Product

Dimension Ød

Cone heigh, nominal

17

18

Dimensions

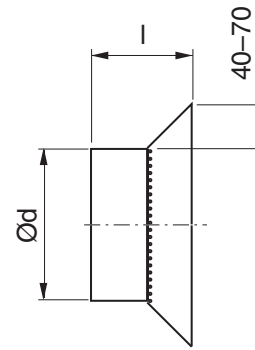

Ød nom	l mm	m kg
100	92	0,15
125	92	0,22
160	92	0,25
200	92	0,32
250	115	0,65
315	130	0,89
400	132	1,00
500	132	1,24
630	122	1,43
800	152	1,79

Take-off with mesh and cone ILKNF 100



Description

To terminate an inlet duct. With female end – fits outside a Safe fitting.

Mesh size 10 × 10 mm.

No Click function – no notches.

Dimensions

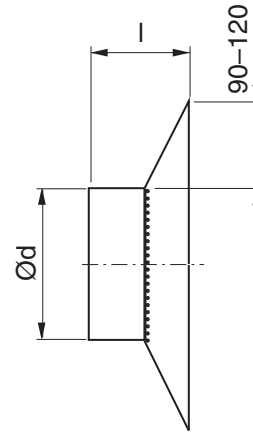

Ød nom	l mm	m kg
100	142	0,48
125	137	0,54
160	140	0,68
200	142	0,99
250	162	1,23
315	155	1,43
400	182	1,73
500	187	2,14
630	197	2,87
800	202	4,21

Ordering example

	ILKNF	200	100
Product			
Dimension Ød			
Cone heigh, nominal			

1

2

3

4

5

6

7

8

9

10

11

12

13

14

15

16

17

18



Description

As standard the angle is 45°.
Different angle available to order.

Dimensions

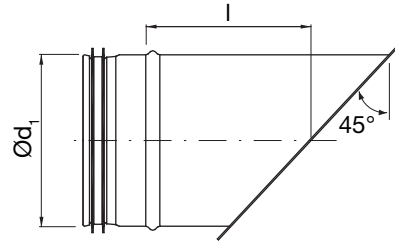

Ød ₁ nom	l mm	m kg
80	80	0,11
100	90	0,15
112	96	0,18
125	103	0,21
140	110	0,25
150	115	0,27
160	120	0,30
180	130	0,36
200	140	0,43
224	152	0,62
250	185	0,87
280	200	1,00
300	210	1,20
315	218	1,20
355	238	1,50
400	280	2,40
450	305	2,90
500	330	3,50
560	360	4,20
600	380	4,60
630	395	5,00
710	455	8,40
800	500	10,0
900	550	12,0
1000	620	16,0
1120	680	19,0
1250	745	23,0

Ordering example

Product **ILVU45** **125**
Dimension Ød₁



Description

Exhaust air stud with internal bird protection net.
 Standard angle is 45°. Other angles are available to order.
 Standard design is galvanized sheet metal. Painted available to order (and extra cost).
 Fits duct SR.

Dimensions

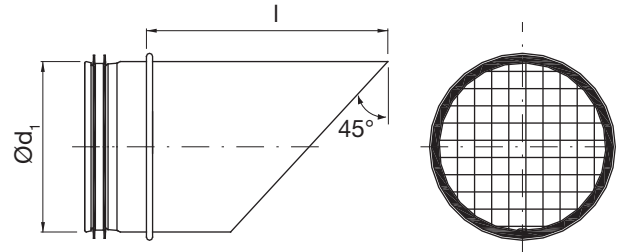

Ød ₁ nom	l mm	m kg
63	160	0,12
80	180	0,17
100	200	0,22
112	210	0,25
125	225	0,29
140	240	0,34
150	250	0,37
160	260	0,41
180	280	0,48
200	300	0,56
224	325	0,80
250	350	1,00
280	380	1,20
300	400	1,30
315	415	1,40
355	455	1,70
400	500	2,50
450	550	3,00
500	600	3,60
560	660	4,30
600	700	4,80
630	730	5,20
710	810	8,40
800	900	10,0
900	1000	12,0
1000	1100	15,0
1120	1220	19,0
1250	1350	23,0

Ordering example

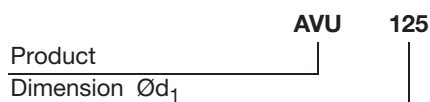

- 1
- 2
- 3
- 4
- 5
- 6
- 7
- 8
- 9
- 10
- 11
- 12
- 13
- 14
- 15
- 16
- 17
- 18



Dimensions

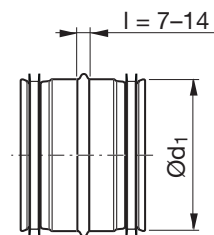

Description

Coupling connector for joining circular ducts.

Ød_1 nom	m kg
63	0,07
80	0,09
100	0,12
112	0,14
125	0,15
140	0,16
150	0,18
160	0,19
180	0,25
200	0,30
224	0,30
250	0,52
280	0,56
300	0,64
315	0,66
355	0,76
400	1,10
450	1,34
500	1,52
560	1,90
600	2,10
630	2,24
710	2,65
800	3,10
900	4,52
1000	5,30
1120	7,03
1250	7,70

Ordering example

Product **NPU** **200**
 Dimension Ød_1



Description

Expanding coupling, intended for installation of ventilation ducts and components of larger dimensions. The coupling makes installation easier and can also be used between circular ducts and fittings without a rubber seal.

The coupling is expanded by means of a threaded bolt, socket no. 13. Can achieve maximum tightness class C.

Dimensions

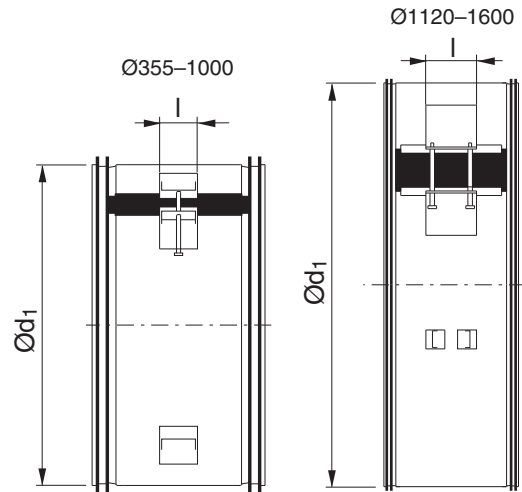

Ød ₁ nom	l mm	m kg
355	45	1,24
400	45	1,64
450	45	1,83
500	45	2,50
560	45	2,95
600	45	3,15
630	45	3,30
710	45	4,30
800	45	4,81
900	45	5,40
1000	45	8,48
1120	120	15,3
1250	120	17,3
1400	120	15,2
1500	120	16,4
1600	120	17,5

Ordering example

Product **NPEU**
 Dimension Ød₁ **500**



Dimensions

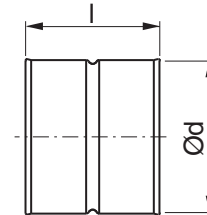

Description

Female coupling for joining fittings.

Has normally not any Click function – hasn't any notches.

Ø 80–315 can upon order be delivered with click function – i.e. with notches.

Ød nom	l mm	m kg
63 *	99	0,06
80 *	99	0,08
100 *	99	0,10
112	99	0,12
125 *	99	0,14
140	99	0,19
150 *	99	0,19
160 *	99	0,21
180	99	0,24
200 *	99	0,26
224	99	0,30
250 *	139	0,42
280	139	0,56
300	139	0,57
315 *	139	0,54
355	139	0,69
400 *	190	1,01
450	190	1,31
500 *	190	1,54
560	190	1,75
600	190	1,84
630	190	1,94
710	230	2,06
800	230	2,35
900	230	4,20
1000	275	5,49
1120	275	9,39
1250	275	11,0

* With turned-over edge

Ordering example

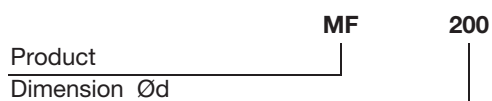



Dimensions

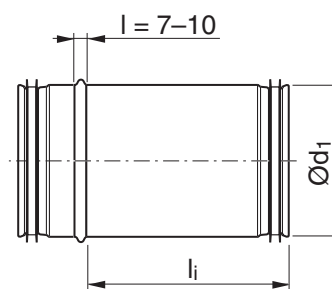

Description

Areas of use:

- To eliminate the accurate length cutting of ducts which the ordinary NPU connector sometimes requires when joining SR ducts. In this case the slide-in coupling shall be secured with screws or pop rivets.
- To make it possible to use a duct that is cut to a too short length – instead of having to cut a new duct to the correct length. In this case the slide-in coupling shall be secured with screws or pop rivets.
- To assist when joining two ducts which run towards each other. E.g. when building a system from two opposing directions. In this case the slide-in coupling shall be secured with screws or pop rivets.
- To assist when inserting or adding an other product into an existing system. E.g. the addition of a new piece of duct to replace a damaged part. In this case the slide-in coupling shall be secured with screws or pop rivets.
- To facilitate access when inspecting and/or cleaning a system – by simply sliding the coupling. The coupling acts as an access cap.

No Click function – has closed turned-over ends (at both ends).

Ordering example

Product	SNPU	160	150
Dimension $\text{Ø}d_1$			
Nominal length L			

$\text{Ø}d_1$ nom	L nom	l_i mm	m kg
80	150	133	0,18
80	300	284	0,32
80	500	548	0,69
100	150	133	0,22
100	300	284	0,40
100	500	548	0,84
112	150	133	0,24
112	300	284	0,43
112	500	548	0,92
125	150	133	0,28
125	300	284	0,50
125	500	548	1,07
140	150	133	0,31
140	300	284	0,56
140	500	548	1,19
150	150	133	0,33
150	300	284	0,59
150	500	548	1,26
160	150	133	0,36
160	300	284	0,65
160	500	548	1,38
180	150	133	0,40
180	300	284	0,72
180	500	548	1,53
200	150	133	0,56
200	300	293	1,02
200	500	548	1,76
224	150	133	0,62
224	300	293	1,13
224	500	548	1,95
250	150	177	0,91
250	300	297	1,35
250	500	527	2,17

$\varnothing d_1$ nom	L nom	l_1 mm	m kg
280	150	177	1,02
280	300	297	1,50
280	500	527	2,41
300	150	177	1,12
300	300	297	1,63
300	500	527	2,61
315	150	177	1,18
315	300	297	1,72
315	500	527	2,76
355	150	177	1,32
355	300	297	1,94
355	500	527	2,93
400	150	175	2,11
400	300	297	2,80
400	500	510	3,10
450	150	175	2,37
450	300	297	3,10
450	500	510	3,80
500	150	175	2,65
500	300	297	3,70
500	500	515	4,50
630	150	175	3,40
630	300	297	4,70
630	500	515	6,00



Description

Areas of use:

- To avoid the necessity of an exact length cutting of a duct when it is difficult to take a proper measure. E.g. the connection of a duct to a stub on an air supply terminal. In this case the slide-in coupling shall be secured with screws or pop rivets.
- To make it possible to use a duct that is cut to a too short length – instead of having to cut a new duct to the correct length. In this case the slide-in coupling shall be secured with screws or pop rivets.
- To eliminate or minimize the number of ordinary duct cuttings at building site – together with pre-cut ducts of shorter lengths. In this case the slide-in coupling shall be secured with screws or pop rivets.
- To assist when inserting or adding an other product into an existing system. E.g. the cutting-in of an extra silencer. In this case the slide-in coupling shall be secured with screws or pop rivets.
- To assist when removing an other product when cleaning a system. E.g. the removal of a damper with a obstructionable blade.
- To facilitate access when inspecting and/or cleaning a system – by simply sliding the coupling. The coupling acts as an access cap.
- To extend the distance between a T-piece and an access cap, e.g. EPFH or KCU, to get the cap outside any insulation. In this case the slide-in coupling shall be secured with screws or pop rivets only at its female end.

No Click function – has a closed turned-over end and hasn't any notches.

Ordering example

	SMFU	200	150
Product			
Dimension $\varnothing d_1$			
Nominal length L			

1

2

3

4

5

6

7

8

9

10

11

12

13

14

15

16

17

18

Dimensions

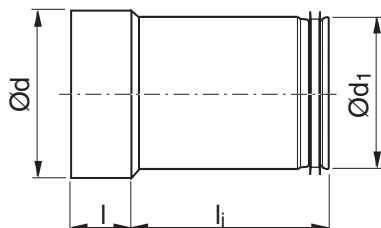

Ød ₁ nom	L nom	l mm	l _i mm	m kg
80	150	40	127	0,16
80	300	40	288	0,30
80	500	40	552	0,65
100	150	40	127	0,20
100	300	40	288	0,38
100	500	40	552	0,81
112	150	40	127	0,23
112	300	40	288	0,43
112	500	40	552	0,93
125	150	40	127	0,25
125	300	40	288	0,47
125	500	40	552	1,01
140	150	40	127	0,28
140	300	40	288	0,53
140	500	40	552	1,13
150	150	40	127	0,29
150	300	40	288	0,57
150	500	40	552	1,21
160	150	40	127	0,31
160	300	40	288	0,60
160	500	40	552	1,29
180	150	40	127	0,35
180	300	40	288	0,68
180	500	40	552	1,45
200	150	40	127	0,49
200	300	40	297	0,96
200	500	40	552	1,67
224	150	40	127	0,55
224	300	40	297	1,08
224	500	40	552	1,87
250	150	60	192	0,90
250	300	60	302	1,28
250	500	60	537	2,10

Ød ₁ nom	L nom	l mm	l _i mm	m kg
280	150	60	192	1,02
280	300	60	302	1,44
280	500	60	537	2,36
300	150	60	192	1,10
300	300	60	302	1,55
300	500	60	537	2,53
315 *	150	60	182	1,11
315 *	300	60	297	1,62
315 *	500	60	537	2,64
355 *	150	60	182	1,26
355 *	300	60	297	1,83
355 *	500	60	537	5,00
400 **	300	80	242	2,65
400 **	500	80	500	6,05
450 **	300	80	242	3,04
450 **	500	80	503	7,20
500 **	300	80	242	3,37
500 **	500	80	503	7,69
630 **	300	80	246	5,90
630 **	500	80	502	8,00

*With stiffening bead

**Design with lockseam



Dimensions

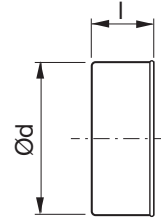

Description

End cap, which fits outside a Safe fitting.

No Click function – no notches.

Ød nom	l mm	m kg
63	40	0,04
80 *	48	0,07
100 *	48	0,11
112 **	48	0,10
125 *	48	0,14
140	48	0,16
150	48	0,14
160 *	48	0,17
180	48	0,24
200 *	46	0,21
224	46	0,35
250 *	68	0,50
280 **	60	0,61
300	60	0,63
315 *	60	0,67
355	60	0,84
400 *	91	1,17
450 **	80	1,48
500 **	80	1,81
560 **	80	2,14
600 **	80	2,37
630 **	80	2,54
710 **	100	3,00
800 **	100	3,54
900 **	100	6,10
1000 **	100	7,30
1120 **	120	9,40
1250 **	120	11,3

* With turned-over edge

** Hand made

Ordering example

Product **EPF**
 Dimension Ød **250**

- 1
- 2
- 3
- 4
- 5
- 6
- 7
- 8
- 9
- 10
- 11
- 12
- 13
- 14
- 15
- 16
- 17
- 18

1

2

3

4

5



6

Description

End cap, which fits inside SR duct.

No Click function – has a closed turned-over end.

7

8

9

10

11

12

13

14

15

16

Ordering example

ESU 160

Product

Dimension $\varnothing d_1$

17

18

Dimensions

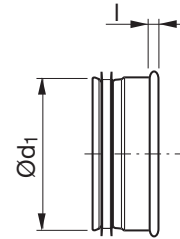

$\varnothing d_1$ nom	l mm	m kg
63	4	0,08
80	10	0,08
100	10	0,12
112	4	0,13
125	10	0,14
140	10	0,14
150	10	0,17
160	10	0,24
180	10	0,28
200	10	0,32
224	10	0,40
250	10	0,37
280	4	0,62
300	10	0,70
315	10	0,80
355	12	0,91
400	12	1,26
450	4	1,48
500	12	2,00
560	4	2,04
600	4	2,38
630	4	2,90
710	4	3,21
800	4	5,00
900	4	5,26
1000	4	9,25
1120	4	7,92
1250	4	10,0