

KXR
INVERTER DRIVEN MULTI-INDOOR UNIT
HEAT RECOVERY CLIMATE CONTROL SYSTEM

SELECTION DATA

1. Specifications
2. Range of usage & limitations
3. Exterior dimensions
4. Piping system
5. Selection chart
6. Electrical wiring

APPLICATION DATA

1. Refrigerant piping
2. Electric wiring

(1) INDOOR UNIT

FDT25 1HKXE2,32 1HKXE2 **FDT**40 1HKXE2,50 1HKXE2,63 1HKXE2

FDT80 1HKXE2,100 1HKXE2,125 1HKXE2

FDTW25 1HKXE2,40 1HKXE2,50 1HKXE2 **FDTW**63 1HKXE2,80 1HKXE2

FDTW100 1HKXE2,125 1HKXE2

FDTs25 1HKXE2,32 1HKXE2 **FDTs**40 1HKXE2,63 1HKXE2

FDR20 1HKXE2,25 1HKXE2 **FDR**40 1HKXE2,50 1HKXE2

FDR63 1HKXE2,80 1HKXE2 **FDR**100 1HKXE2,125 1HKXE2

FDUM32 1HKXE2,40 1HKXE2 **FDUM**50 1HKXE2,63 1HKXE2,80 1HKXE2

FDUM100 1HKXE2,125 1HKXE2

FDE32 1HKXE2,40 1HKXE2 **FDE**50 1HKXE2,63 1HKXE2

FDE100 1HKXE2,125 1HKXE2

FDKY25 1HKXE2,32 1HKXE2,40 1HKXE2

FDKY50 1HKXE2,63 1HKXE2

FDFL25 1HKXE2,40 1HKXE2,63 1HKXE2

(2) OUTDOOR UNIT

FDC200 1HKXRE2,250 1HKXRE2

1 SELECTION DATA

1.1 Specifications

(1) Indoor unit

(a) Ceiling recessed type (FDT)

Models FDT251HKXE2, 321HKXE2

Item	Models	FDT251HKXE2 ⁽³⁾	FDT321HKXE2 ⁽³⁾
Nominal cooling capacity*1	W	2800	3600
Nominal heating capacity*2	W	3200	4000
Power source		1 Phase 220/240V 50Hz	
Noise level	dB(A)	Hi: 40 Me: 38 Lo: 35	
Exterior dimensions Height × Width × Depth	mm	Unit:290 × 840 × 840 Panel:22 × 950 × 950	
Net weight	kg	Unit:25 Panel:6	
Refrigerant equipment Heat exchanger		Louver fine & inner grooved tubing	
Refrigerant control		Electronic Expansion Valve +Capillary tube	
Refrigerant		R22	
Quantity	kg	—	
Air handling equipment Fan type & Q'ty		Turbo fan × 1	
Motor	W	20 × 1	
Starting method		Line starting	
Air flow(Standard)	CMM	Hi: 12 Me: 11 Lo: 10	
Fresh air intake		Possible	
Air filter, Q'ty		Long life filter × 1(Washable)	
Shock & vibration absorber		Rubber sleeve(for fan motor)	
Insulation (noise & heat)		Polyurethane foam	
Operation control Operation switch		Remote control switch (Optional:RC-HKXR-SA8-E2)	
Room temperature control		Thermostat by electronics	
Safety equipment		Internal thermostat for fan motor. Frost protection thermostat	
Installation data Refrigerant piping size	mm(in)	Liquid line:φ 6.35(1/4"), Gas line:φ 12.7(1/2")	
Connecting method		Flare piping	
Drain hose		Connectable with VP25	
Insulation for piping		Necessary (both Liquid & Gas line)	
Accessories		Mounting kit	
Optional parts		Decorative Panel	
Outdoor units to be combined		FDC2001HKXRE2, 2501HKXRE2	

Notes (1) The data are measured at the following conditions.

Item	Indoor air temperature		Outdoor air temperature		Standards
	DB	WB	DB	WB	
Operation Cooling*1	27℃	19℃	35℃	24℃	ISO-A,,JIS B8616
Heating*2	20℃	—	7℃	6℃	

(2) This packaged air conditioner is manufactured and tested in conformity with the following standard.
JIS B8616"UNITARY AIR CONDITIONERS"

●Decorative Panel model (Optional)

Item	Panel Part No.
Model FDT251,321type	T-PSA-31W-E

(3) The number "2", following the type of each model, represents"CE-marked model" especially for European Union, and for European nations which require CE marking.

Models FDT401HKXE2, 501HKXE2, 631HKXE2

Item	Models	FDT401HKXE2 ⁽³⁾	FDT501HKXE2 ⁽³⁾	FDT631HKXE2 ⁽³⁾
Nominal cooling capacity* ¹	W	4500	5600	7100
Nominal heating capacity* ²	W	5000	6300	8000
Power source		1 Phase 220/240V 50Hz		
Noise level	dB(A)	Hi: 41 Me: 38 Lo: 36		Hi: 42 Me: 40 Lo: 39
Exterior dimensions Height × Width × Depth	mm	Unit:290 × 840 × 840 Panel:22 × 950 × 950		
Net weight	kg	Unit:25 Panel:6		Unit:26 Panel:6
Refrigerant equipment Heat exchanger		Louver fine & inner grooved tubing		
Refrigerant control		Electronic Expansion Valve +Capillary tube		
Refrigerant		R22		
Quantity	kg	—		
Air handling equipment Fan type & Q'ty		Turbo fan × 1		
Motor	W	25 × 1		35 × 1
Starting method		Line starting		
Air flow(Standard)	CMM	Hi: 15 Me: 12 Lo: 10		Hi: 16 Me: 13 Lo: 11
Fresh air intake		Possible		
Air filter, Q'ty		Long life filter × 1(Washable)		
Shock & vibration absorber		Rubber sleeve(for fan motor)		
Insulation (noise & heat)		Polyurethane foam		
Operation control Operation switch		Remote control switch (Optional:RC-HKXR-SA8-E2)		
Room temperature control		Thermostat by electronics		
Safety equipment		Internal thermostat for fan motor. Frost protection thermostat		
Installation data Refrigerant piping size	mm(in)	Liquid line:φ 6.35(1/4") Gas line:φ 12.7(1/2")	Liquid line:φ 9.52(3/8") Gas line:φ 15.88(5/8")	
Connecting method		Flare piping		
Drain hose		Connectable with VP25		
Insulation for piping		Necessary (both Liquid & Gas lines)		
Accessories		Mounting kit		
Optional parts		Decorative Panel		
Outdoor units to be combined		FDC2001HKXRE2, 2501HKXRE2		

Notes (1) The data are measured at the following conditions.

Item	Indoor air temperature		Outdoor air temperature		Standards
	DB	WB	DB	WB	
Operation					
Cooling* ¹	27℃	19℃	35℃	24℃	ISO-A,JIS B8616
Heating* ²	20℃	—	7℃	6℃	

(2) This packaged air conditioner is manufactured and tested in conformity with the following standard.
JIS B8616"UNITARY AIR CONDITIONERS"

●Decorative Panel model (Optional)

Item	Panel Part No.
Model FDT401,501,631type	T-PSA-31W-E

(3) The number "2", following the type of each model, represents"CE-marked model" especially for European Union, and for European nations which require CE marking.

Models FDT801HKXE2, 1001HKXE2, 1251HKXE2

Item		Models	FDT801HKXE2 ⁽³⁾	FDT1001HKXE2 ⁽³⁾	FDT1251HKXE2 ⁽³⁾
Nominal cooling capacity*1	W		9000	11200	14000
Nominal heating capacity*2	W		10000	12500	16000
Power source			1 Phase 220/240V 50Hz		
Noise level	dB(A)		Hi: 44 Me: 42 Lo: 39	Hi: 52 Me:47 Lo: 42	Hi: 54 Me: 48 Lo: 45
Exterior dimensions Height × Width × Depth	mm		Unit: 290 × 840 × 840 Panel:22 × 950 × 950	Unit: 340 × 840 × 840 Panel:22 × 950 × 950	
Net weight	kg		Unit:26 Panel:6	Unit:31 Panel:6	Unit:33 Panel:6
Refrigerant equipment Heat exchanger			Louver fins & inner grooved tubing		
Refrigerant control			Electronic Expansion Valve +Capillary tube		
Refrigerant			R22		
Quantity	kg		—		
Air handling equipment Fan type & Q'ty			Turbo fan × 1		
Motor	W		40×1	80×1	130×1
Starting method			Line starting		
Air flow(Standard)	CMM		Hi: 20 Me: 15 Lo: 12	Hi: 28 Me: 24 Lo: 21	Hi: 30 Me: 26 Lo: 22
Fresh air intake			Possible		
Air filter, Q'ty			Long life filter × 1(Washable)		
Shock & vibration absorber			Rubber sleeve(for fan motor)		
Insulation (noise & heat)			Polyurethane foam		
Operation control Operation switch			Remote control switch (Optional:RC-HKXR-SA8-E2)		
Room temperature control			Thermostat by electronics		
Safety equipment			Internal thermostat for fan motor. Frost protection thermostat		
Installation data Refrigerant piping size	mm(in)		Liquid line:φ9.52(3/8") Gas line:φ15.88(5/8")	Liquid line:φ9.52(3/8") Gas line:φ19.05(3/4")	
Connecting method			Flare piping		
Drain hose			Connectable with VP25		
Insulation for piping			Necessary (both Liquid & Gas lines)		
Accessories			Mounting kit		
Optional parts			Decorative Panel		
Outdoor units to be combined			FDC2001HKXRE2, 2501HKXRE2		

Notes (1) The data are measured at the following conditions.

Item	Indoor air temperature		Outdoor air temperature		Standards
	DB	WB	DB	WB	
Operation					
Cooling*1	27℃	19℃	35℃	24℃	ISO-A,JIS B8616
Heating*2	20℃	—	7℃	6℃	

(2) This packaged air conditioner is manufactured and tested in conformity with the following standard.
JIS B8616"UNITARY AIR CONDITIONERS"

●Decorative Panel model (Optional)

Item	Panel Part No.
Model FDT801,1001,1251type	T-PSA-31W-E

(3) The number "2", following the type of each model, represents"CE-marked model" especially for European Union, and for European nations which require CE marking.

(b) 2-way outlet ceiling recessed type (FDTW)

Models FDTW251HKXE2, 401HKXE2, 501HKXE2

Item	Models	FDTW251HKXE2 ⁽³⁾	FDTW401HKXE2 ⁽³⁾	FDTW501HKXE2 ⁽³⁾
		Nominal cooling capacity* ¹	W	2800
Nominal heating capacity* ²	W	3200	5000	6300
Power source		1 Phase 220/240V 50Hz		
Noise level	dB(A)	Hi: 42 Me:38 Lo: 33		
Exterior dimensions Height × Width × Depth	mm	Unit:380× 809× 620 Panel:8 × 1055 × 680		
Net weight	kg	Unit:31 Panel:10		
Refrigerant equipment Heat exchanger		Louver fins & inner grooved tubing		
Refrigerant control		Electronic Expansion Valve +Capillary tube		
Refrigerant		R22		
Quantity	kg	—		
Air handling equipment Fan type & Q'ty		Centrifugal fan × 2		
Motor	W	55 × 1		
Starting method		Line starting		
Air flow(Standard)	CMM	Hi: 15 Me: 12 Lo: 9		
Fresh air intake		Possible		
Air filter, Q'ty		Long life filter × 2(Washable)		
Shock & vibration absorber		Rubber sleeve(for fan motor)		
Insulation (noise & heat)		Polyurethane foam		
Operation control Operation switch		Remote control switch (Optional:RC-HKXR-SA8-E2)		
Room temperature control		Thermostat by electronics		
Safety equipment		Internal thermostat for fan motor. Frost protection thermostat		
Installation data Refrigerant piping size	mm(in)	Liquid line:φ 6.35(1/4") Gas line:φ 12.7(1/2")		Liquid line:φ 9.52(3/8") Gas line:φ 15.88(5/8")
Connecting method		Flare piping		
Drain hose		Connectable with VP25		
Insulation for piping		Necessary (both Liquid & Gas lines)		
Accessories		Mounting kit		
Optional parts		Decorative Panel		
Outdoor units to be combined		FDC2001HKXRE2, 2501HKXRE2		

Notes (1) The data are measured at the following conditions.

Item	Indoor air temperature		Outdoor air temperature		Standards
	DB	WB	DB	WB	
Operation					
Cooling* ¹	27℃	19℃	35℃	24℃	ISO-A,JIS B8616
Heating* ²	20℃	—	7℃	6℃	

(2) This packaged air conditioner is manufactured and tested in conformity with the following standard.
JIS B8616"UNITARY AIR CONDITIONERS"

●Decorative Panel model (Optional)

Item	Panel Part No.	
	Standard type	Attachment of ceiling material type
Model		
FDTW251,401,501type	TW-PSA-28W-E	TW-PSB-28W-E

(3) The number "2", following the type of each model, represents"CE-marked model" especially for European Union, and for European nations which require CE marking.

Models FDTW631HKXE2, 801HKXE2

Item		Models	FDTW631HKXE2 ⁽³⁾	FDTW801HKXE2 ⁽³⁾
Nominal cooling capacity* ¹	W		7100	9000
Nominal heating capacity* ²	W		8000	10000
Power source			1 Phase 220/240V 50Hz	
Noise level	dB(A)		Hi: 42 Me: 39 Lo: 35	Hi: 42 Me: 40 Lo: 36
Exterior dimensions Height × Width × Depth	mm		Unit:380 × 1054 × 620	Panel:8 × 1300 × 680
Net weight	kg		Unit:37	Panel:11
Refrigerant equipment Heat exchanger			Louver fins & inner grooved tubing	
Refrigerant control			Electronic Expansion Valve +Capillary tube	
Refrigerant			R22	
Quantity	kg		—	
Air handling equipment Fan type & Q'ty			Centrifugal fan × 2	
Motor	W		55×1	80×1
Starting method			Line starting	
Air flow(Standard)	CMM		Hi: 16 Me: 13 Lo: 11	Hi: 19 Me: 16 Lo: 12
Fresh air intake			Possible	
Air filter, Q'ty			Long life filter × 2(Washable)	
Shock & vibration absorber			Rubber sleeve(for fan motor)	
Insulation (noise & heat)			Polyurethane foam	
Operation control Operation switch			Remote control switch (Optional:RC-HKXR-SA8-E2)	
Room temperature control			Thermostat by electronics	
Safety equipment			Internal thermostat for fan motor. Frost protection thermostat	
Installation data Refrigerant piping size	mm(in)		Liquid line:φ 9.52(3/8"),Gas line:φ 15.88(5/8")	
Connecting method			Flare piping	
Drain hose			Connectable with VP25	
Insulation for piping			Necessary (both Liquid & Gas lines)	
Accessories			Mounting kit	
Optional parts			Decorative Panel	
Outdoor units to be combined			FDC2001HKXRE2, 2501HKXRE2	

Notes (1) The data are measured at the following conditions.

Item	Indoor air temperature		Outdoor air temperature		Standards
	DB	WB	DB	WB	
Operation					
Cooling* ¹	27℃	19℃	35℃	24℃	ISO-A,JIS B8616
Heating* ²	20℃	—	7℃	6℃	

(2) This packaged air conditioner is manufactured and tested in conformity with the following standard.
JIS B8616"UNITARY AIR CONDITIONERS"

●Decorative Panel model (Optional)

Item	Panel Part No.	
	Standard type	Attachment of ceiling material type
Model		
FDTW631,801type	TW-PSA-38W-E	TW-PSB-38W-E

(3) The number "2", following the type of each model, represents"CE-marked model" especially for European Union, and for European nations which require CE marking.

Models FDTW1001HKXE2, 1251HKXE2

Item		Models	FDTW1001HKXE2 ⁽³⁾	FDTW1251HKXE2 ⁽³⁾
Nominal cooling capacity*1	W		11200	14000
Nominal heating capacity*2	W		12500	16000
Power source			1 Phase 220/240V 50Hz	
Noise level	dB(A)		Hi: 44 Me: 41 Lo: 37	Hi: 46 Me: 43 Lo: 38
Exterior dimensions Height × Width × Depth	mm		Unit:380 × 1524 × 620	Panel:8 × 1770 × 680
Net weight	kg		Unit:53	Panel:13
Refrigerant equipment Heat exchanger			Louver fins & inner grooved tubing	
Refrigerant control			Electronic Expansion Valve +Capillary tube	
Refrigerant			R22	
Quantity	kg		—	
Air handling equipment Fan type & Q'ty			Centrifugal fan × 2	
Motor	W		55 × 1,40 × 1	80 × 1,45 × 1
Starting method			Line starting	
Air flow(Standard)	CMM		Hi: 28 Me: 24 Lo: 20	Hi: 30 Me: 26 Lo: 22
Fresh air intake			Possible	
Air filter, Q'ty			Long life filter × 2(Washable)	
Shock & vibration absorber			Rubber sleeve(for fan motor)	
Insulation (noise & heat)			Polyurethane foam	
Operation control Operation switch			Remote control switch (Optional:RC-HKXR-SA8-E2)	
Room temperature control			Thermostat by electronics	
Safety equipment			Internal thermostat for fan motor. Frost protection thermostat	
Installation data Refrigerant piping size	mm(in)		Liquid line:φ 9.52(3/8"),Gas line:φ 19.05(3/4")	
Connecting method			Flare piping	
Drain hose			Connectable with VP25	
Insulation for piping			Necessary (both Liquid & Gas linse)	
Accessories			Mounting kit	
Optional parts			Decorative Panel	
Outdoor units to be combined			FDC2001HKXRE2, 2501HKXRE2	

Notes (1) The data are measured at the following conditions.

Item	Indoor air temperature		Outdoor air temperature		Standards
	DB	WB	DB	WB	
Operation					
Cooling*1	27℃	19℃	35℃	24℃	ISO-A,JIS B8616
Heating*2	20℃	—	7℃	6℃	

(2) This packaged air conditioner is manufactured and tested in conformity with the following standard.

JIS B8616"UNITARY AIR CONDITIONERS"

●Decorative Panel model (Optional)

Item	Panel Part No.	
	Standard type	Attachment of ceiling material type
Model		
FDTW1001,1251type	TW-PSA-48W-E	TW-PSB-48W-E

(3) The number "2", following the type of each model, represents"CE-marked model" especially for European Union, and for European nations which require CE marking.

(c) 1-way outlet ceiling recessed type (FDTS)

Models FDTS251HKXE2, 321HKXE2

Item		Model	FDTS251HKXE2 ⁽³⁾	FDTS321HKXE2 ⁽³⁾
Nominal cooling capacity*1	W		2800	3600
Nominal heating capacity*2	W		3200	4000
Power source			1 Phase 220/240V 50Hz	
Noise level	dB(A)		Hi: 40 Me: 39 Lo: 38	
Exterior dimensions Height × Width × Depth	mm		Unit:194 × 1040 × 650 Panel:10 × 1290 × 770	
Net weight	Kg		Unit:26 Panel:6	
Refrigerant equipment Heat exchanger			Louver fine & inner grooved tubing	
Refrigerant control			Electronic Expansion Valve +Capillary tube	
Refrigerant			R22	
Quantity	Kg		—	
Air handling equipment Fan type & Q'ty			Centrifugal fan × 2	
Motor	W		35 × 1	
Starting method			Line starting	
Air flow(Standard)	CMM		Hi: 12 Me: 11 Lo: 10	
Fresh air intake			Possible	
Air filter, Q'ty			Long life filter × 1(Washable)	
Shock & vibration absorber			Rubber sleeve(for fan motor)	
Insulation (noise & heat)			Polyurethane foam	
Operation control Operation switch			Remote control switch (Optional:RC-HKXR-SA8-E2)	
Room temperature control			Thermostat by electronics	
Safety equipment			Internal thermostat for fan motor. Frost protection thermostat	
Installation data Refrigerant piping size	mm(in)		Liquid line: φ6.35(1/4"), Gas line: φ12.7(1/2")	
Connecting method			Flare piping	
Drain hose			Connectable with VP25	
Insulation for piping			Necessary (both Liquid & Gas lines)	
Accessories			Mounting kit	
Optional parts			Decorative Panel	
Outdoor units to be combined			FDC2001HKXRE2, 2501HKXRE2	

Notes (1) The data are measured at the following conditions.

Item	Indoor air temperature		Outdoor air temperature		Standards
	DB	WB	DB	WB	
Operation					
Cooling*1	27℃	19℃	35℃	24℃	ISO-A, JIS B8616
Heating*2	20℃	—	7℃	6℃	

(2) This packaged air conditioner is manufactured and tested in conformity with the following standard.
JIS B8616 "UNITARY AIR CONDITIONERS"

●Decorative Panel model (Optional)

Item	Panel Part No.
Model	With Auto Swing
FDTS251,321 type	TS-PSA-26W-E

(3) The number "2", following the type of each model, represents "CE-marked model" especially for European Union, and for European nations which require CE marking.

Models FDTS401HKXE2, 631HKXE2

Item		Model	FDTS401HKXE2 ⁽³⁾	FDTS631HKXE2 ⁽³⁾
Nominal cooling capacity*1	W		4500	7100
Nominal heating capacity*2	W		5000	8000
Power source			1 Phase 220/240V 50Hz	
Noise level	dB(A)		Hi: 43 Me: 40 Lo: 38	Hi: 44 Me: 40 Lo: 38
Exterior dimensions Height × Width × Depth	mm		Unit:194 × 1040 × 650 Panel:10 × 1290 × 770	Unit:194 × 1300 × 650 Panel:10 × 1500 × 790
Net weight	kg		Unit:26 Panel:6	Unit:30 Panel:7
Refrigerant equipment Heat exchanger			Louver fins & inner grooved tubing	
Refrigerant control			Electronic Expansion Valve +Capillary tube	
Refrigerant			R22	
Quantity	kg		—	
Air handling equipment Fan type & Qty			Centrifugal fan × 2	Centrifugal fan × 4
Motor	W		40 × 1	25 × 2
Starting method			Line starting	
Air flow(Standard)	CMM		Hi: 14 Me: 12 Lo: 10	Hi: 18 Me: 15 Lo: 12
Fresh air intake			Possible	
Air filter, Qty			Long life filter × 1(Washable)	
Shock & vibration absorber			Rubber sleeve(for fan motor)	
Insulation (noise & heat)			Polyurethane foam	
Operation control Operation switch			Remote control switch (Optional:RC-HKXR-SA8-E2)	
Room temperature control			Thermostat by electronics	
Safety equipment			Internal thermostat for fan motor. Frost protection thermostat	
Installation data Refrigerant piping size	mm(in)		Liquid line:φ 6.35(1/4") Gas line:φ 12.7(1/2")	Liquid line:φ 9.52(3/8") Gas line:φ 15.88(5/8")
Connecting method			Flare piping	
Drain hose			Connectable with VP25	
Insulation for piping			Necessary (both Liquid & Gas line)	
Accessories			Mounting kit	
Optional parts			Decorative Panel	
Outdoor units to be combined			FDC2001HKXRE2, 2501HKXRE2	

Notes (1) The data are measured at the following conditions.

Item	Indoor air temperature		Outdoor air temperature		Standards
	DB	WB	DB	WB	
Operation					
Cooling*1	27℃	19℃	35℃	24℃	ISO-A,JIS B8616
Heating*2	20℃	—	7℃	6℃	

(2) This packaged air conditioner is manufactured and tested in conformity with the following standard.
JIS B8616"UNITARY AIR CONDITIONERS"

●Decorative Panel model (Optional)

Item	Panel Part No.
Model	With Auto Swing
FDTS401 type	TS-PSA-26W-E
FDTS631 type	TS-PSA-36W-E

(3) The number "2", following the type of each model, represents"CE-marked model" especially for European Union, and for European nations which require CE marking.

(d) Cassetteria type (FDR)

Models FDR201HKXE2, 251HKXE2

Item	Models	FDR201HKXE2 ⁽⁴⁾		FDR251HKXE2 ⁽⁴⁾	
		Silent panel	Canvas panel	Silent panel	Canvas panel
Air inlet panel					
Panel model (Option)		R-PNLS-26W-E	R-PNLC-26W-E	R-PNLS-26W-E	R-PNLC-26W-E
Nominal cooling capacity* ¹	W	2200		2800	
Nominal heating capacity* ²	W	2500		3200	
Power source		1 Phase 220/240V 50Hz			
Noise level	dB(A)	Hi: 41 Me: 39 Lo: 36	Hi: 42 Me: 40 Lo: 37	Hi: 42 Me: 40 Lo: 37	Hi: 43 Me: 41 Lo: 38
Exterior dimensions Height × Width × Depth	mm	Unit:355 × 750 × 635 Panel:10 × 1040 × 750	Unit:355 × 750 × 635 Panel:10 × 864 × 585	Unit:355 × 750 × 635 Panel:10 × 1040 × 750	Unit:355 × 750 × 635 Panel:10 × 864 × 585
Net weight	kg	Unit:30 Panel:7	Unit:30 Panel:5	Unit:30 Panel:7	Unit:30 Panel:5
Refrigerant equipment Heat exchanger		Louver fins & inner grooved tubing			
Refrigerant control		Electronic Expansion Valve + Capillary tube			
Refrigerant		R22			
Quantity	kg	—			
Air handling equipment Fan type & Q'ty		Centrifugal fan × 2			
Motor	W	40 × 1		50 × 1	
Starting method		Line starting			
Air flow(Standard)	CMM	Hi: 10 Me: 9 Lo: 8		Hi: 12 Me: 11 Lo: 10	
Available static pressure (at Me)	mmAq	Standard:4.5, Hi speed:8.5			
Fresh air intake		Side or back			
Air filter Q'ty		Long life filter × 1(Washable)			
Shock & vibration absorber		Rubber sleeve(for fan motor)			
Insulation (noise & heat)		Polyurethane foam			
Operation control Operation switch		Remote control switch (Optional:RC-HKXR-SN8-E2)			
Room temperature control		Thermostat by electronics			
Safety equipment		Internal thermostat for fan motor. Frost protection thermostat			
Installation data Refrigerant piping size	mm(in)	Liquid line:φ 6.35(1/4"), Gas line:φ 12.7(1/2")			
Connecting method		Flare piping			
Drain hose		Connectable with VP25			
Insulation for piping		Necessary (both Liquid & Gas lines)			
Accessories		Mounting kit			
Optional parts		Silent panel, Canvas panel, Canvas duct			
Outdoor units to be combined		FDC2001HKXRE2, 2501HKXRE2			

Notes (1)The data are measured at the following conditions.

Item	Indoor air temperature		Outdoor air temperature		Standards
	DB	WB	DB	WB	
Operation					
Cooling* ¹	27℃	19℃	35℃	24℃	ISO-A, JIS B8616
Heating* ²	20℃	—	7℃	6℃	

(2)This packaged air conditioner is manufactured and tested in conformity with the following standard.

JIS B8616"UNITARY AIR CONDITIONERS"

(3)Canvas panel is used in combination with following canvas duct
Canvas duct: HA01503

(4)The number "2" following the type of each model, represents "CE-marked model" especially for European Union, and for European nations which require CE marking.

(5)Add the canvas duct length to the unit height for the canvas type.

Models FDR401HKXE2, 501HKXE2

Item	Models	FDR401HKXE2 ⁽⁴⁾		FDR501HKXE2 ⁽⁴⁾	
		Silent panel	Canvas panel	Silent panel	Canvas panel
Air inlet panel		Silent panel	Canvas panel	Silent panel	Canvas panel
Panel model (Option)		R-PNLS-26W-E	R-PNLC-26W-E	R-PNLS-26W-E	R-PNLC-26W-E
Nominal cooling capacity* ¹	W	4500		5600	
Nominal heating capacity* ²	W	5000		6300	
Power source		1 Phase 220/240V 50Hz			
Noise level	dB(A)	Hi: 43 Me: 40 Lo: 37	Hi: 44 Me: 41 Lo: 38	Hi:43 Me: 40 Lo: 37	Hi: 44 Me: 41 Lo: 38
Exterior dimensions Height × Width × Depth	mm	Unit:355 × 750 × 635 Panel:10 × 1040 × 750	Unit:355 × 750 × 635 Panel:10 × 864 × 585	Unit:355 × 750 × 635 Panel:10 × 1040 × 750	Unit:355 × 750 × 635 Panel:10 × 864 × 585
Net weight	kg	Unit:30 Panel:7	Unit:30 Panel:5	Unit:35 Panel:7	Unit:35 Panel:5
Refrigerant equipment Heat exchanger		Louver fins & inner grooved tubing			
Refrigerant control		Electronic Expansion Valve +Capillary tube			
Refrigerant		R22			
Quantity	kg	—			
Air handling equipment Fan type&Q'ty		Centrifugal fan × 2			
Motor	W	55 × 1			
Starting method		Line starting			
Air flow(Standard)	CMM	Hi: 14 Me: 12 Lo: 11			
Available static pressure (at Me)	mmAq	Standard:5.0, Hi speed:8.5			
Fresh air intake		Side or back			
Air filter Q'ty		Long life filter × 1(Washable)			
Shock & vibration absorber		Rubber sleeve(for fan motor)			
Insulation (noise & heat)		Polyurethane foam			
Operation control Operation switch		Remote control switch (Optional:RC-HKXR-SN8-E2)			
Room temperature control		Thermostat by electronics			
Safety equipment		Internal thermostat for fan motor. Frost protection thermostat			
Installation data Refrigerant piping size	mm(in)	Liquid line:φ 6.35(1/4") Gas line:φ 12.7(1/2")		Liquid line:φ 9.52(3/8") Gas line:φ 15.88(5/8")	
Connecting method		Flare piping			
Drain hose		Connectable with VP25			
Insulation for piping		Necessary (both Liquid & Gas lines)			
Accessories		Mounting kit			
Optional parts		Silent panel, Canvas panel, Canvas duct			
Outdoor units to be combined		FDC2001HKXRE2, 2501HKXRE2			

Notes (1)The data are measured at the following conditions.

Item	Indoor air temperature		Outdoor air temperature		Standards
	DB	WB	DB	WB	
Operation					
Cooling* ¹	27℃	19℃	35℃	24℃	ISO-A,JIS B8616
Heating* ²	20℃	—	7℃	6℃	

(2)This packaged air conditioner is manufactured and tested in conformity with the following standard.
JIS B8616"UNITARY AIR CONDITIONERS"

(3)Canvas panel is used in combination with follwing canvas duct
Canvas duct: HA01503

(4)The number "2",following the type of each model,represents"CE-marked model"especially for European Union, and for Europearn nations which require CE marking.

(5)Add the canvas duct lenght to the unit height for the canvas type.

Models FDR631HKXE2, 801HKXE2

Item	Models	FDR631HKXE2 ⁽⁴⁾		FDR801HKXE2 ⁽⁴⁾	
		Silent panel	Canvas panel	Silent panel	Canvas panel
Air inlet panel		Silent panel	Canvas panel	Silent panel	Canvas panel
Panel model (Option)		R-PNLS-36W-E	R-PNLC-36W-E	R-PNLS-36W-E	R-PNLC-36W-E
Nominal cooling capacity* ¹	W	7100		9000	
Nominal heating capacity* ²	W	8000		10000	
Power source		1 Phase 220/240V 50Hz			
Noise level	dB(A)	Hi: 43 Me: 40 Lo: 37	Hi: 44 Me: 41 Lo: 38	Hi: 44 Me: 40 Lo: 37	Hi: 44 Me: 41 Lo: 38
Exterior dimensions Height × Width × Depth	mm	Unit:355 × 950 × 635 Panel:10 × 1240 × 750	Unit:355 × 950 × 635 Panel:10 × 1064 × 585	Unit:355 × 950 × 635 Panel:10 × 1240 × 750	Unit:355 × 950 × 635 Panel:10 × 1040 × 585
Net weight	kg	Unit:35 Panel:8	Unit:35 Panel:6	Unit:50 Panel:8	Unit:50 Panel:6
Refrigerant equipment Heat exchanger		Louver fins & inner grooved tubing			
Refrigerant control		Electronic Expansion Valve +Capillary tube			
Refrigerant		R22			
Quantity	Kg	—			
Air handling equipment Fan type&Q'ty		Centrifugal fan × 2			
Motor	W	90 × 1		100 × 1	
Starting method		Line starting			
Air flow(Standard)	CMM	Hi: 18 Me: 16 Lo: 14		Hi: 20 Me: 18 Lo: 15	
Available static pressure (at Me)	mmAp	Standard:4.5, Hi speed:8.0			
Fresh air intake		Side or back			
Air filter Q'ty		Long life filter × 1(Washable)			
Shock & vibration absorber		Rubber sleeve(for fan motor)			
Insulation (noise & heat)		Polyurethane foam			
Operation control Operation switch		Remote control switch (Optional:RC-HKXR-SN8-E2)			
Room temperature control		Thermostat by electronics			
Safety equipment		Internal thermostat for fan motor. Frost protection thermostat			
Installation data Refrigerant piping size	mm(in)	Liquid line:φ 9.52(3/8"), Gas line:φ 15.88(5/8")			
Connecting method		Flare piping			
Drain hose		Connectable with VP25			
Insulation for piping		Necessary (both Liquid & Gas lines)			
Accessories		Mounting kit			
Optional parts		Silent panel, Canvas panel, Canvas duct			
Outdoor units to be combined		FDC2001HKXRE2, 2501HKXRE2			

Notes (1)The data are measured at the following conditions.

Item	Indoor air temperature		Outdoor air temperature		Standards
	DB	WB	DB	WB	
Operation					
Cooling* ¹	27℃	19℃	35℃	24℃	ISO-A,JIS B8616
Heating* ²	20℃	—	7℃	6℃	

(2)This packaged air conditioner is manufactured and tested in conformity with the following standard.
JIS B8616"UNITARY AIR CONDITIONERS"

(3)Canvas panel is used in combination with follwing canvas duct
Canvas duct: FDR801 type: HA01503
FDR1001 type: HA01484

(4)The number "2",following the type of each model,represents"CE-marked model"especially for European Union, and for European nations which require CE marking.

(5)Add the canvas duct length to the unit height for the canvas type.

Models FDR1001HKXE2, 1251HKXE2

Item	Models	FDR1001HKXE2 ⁽⁴⁾		FDR1251HKXE2 ⁽⁴⁾	
		Silent panel	Canvas panel	Silent panel	Canvas panel
Air inlet panel					
Panel model (Option)		R-PNLS-46W-E	R-PNLC-46W-E	R-PNLS-46W-E	R-PNLC-46W-E
Nominal cooling capacity* ¹	W	11200		14000	
Nominal heating capacity* ²	W	12500		16000	
Power source		1 Phase 220/240V 50Hz			
Noise level	dB(A)	Hi: 45 Me: 42 Lo: 38	Hi: 46 Me: 43 Lo: 39	Hi: 46 Me: 43 Lo: 39	Hi: 47 Me: 44 Lo: 40
Exterior dimensions Height × Width × Depth	mm	Unit:406 × 1370 × 635 Panel:10 × 1660 × 750	Unit:406 × 1370 × 635 Panel:10 × 1484 × 585	Unit:406 × 1370 × 635 Panel:10 × 1660 × 750	Unit:406 × 1370 × 635 Panel:10 × 1484 × 585
Net weight	kg	Unit:50 Panel:9	Unit:50 Panel:7	Unit:52 Panel:9	Unit:52 Panel:7
Refrigerant equipment Heat exchanger		Louver fins & inner grooved tubing			
Refrigerant control		Electronic Expansion Valve +Capillary tube			
Refrigerant		R22			
Quantity	kg	—			
Air handling equipment Fan type&Q'ty		Centrifugal fan × 3			
Motor	W	45 × 1, 90 × 1		50 × 1, 100 × 1	
Starting method		Line starting			
Air flow(Standard)	CMM	Hi: 28 Me: 25 Lo: 22		Hi: 34 Me: 31 Lo: 27	
Available static pressure (at Me)	mmAq	Standard:5.0, Hi speed:8.0			
Fresh air intake		Side or back			
Air filter Q'ty		Long life filter × 2(Washable)			
Shock & vibration absorber		Rubber sleeve(for fan motor)			
Insulation (noise & heat)		Polyurethane foam			
Operation control Operation switch		Remote control switch (Optional:RC-HKXR-SN8-E2)			
Room temperature control		Thermostat by electronics			
Safety equipment		Internal thermostat for fan motor. Frost protection thermostat			
Installation data Refrigerant piping size	mm(in)	Liquid line:φ 9.52(3/8"), Gas line:φ 19.05(3/4")			
Connecting method		Flare piping			
Drain hose		Connectable with VP25			
Insulation for piping		Necessary (both Liquid & Gas lines)			
Accessories		Mounting kit			
Optional parts		Silent panel, Canvas panel, Canvas duct			
Outdoor units to be combined		FDC2001HKXRE2, 2501HKXRE2			

Notes (1)The data are measured at the following conditions.

Item	Indoor air temperature		Outdoor air temperature		Standards
	DB	WB	DB	WB	
Operation					
Cooling* ¹	27℃	19℃	35℃	24℃	ISO-A, JIS B8616
Heating* ²	20℃	—	7℃	6℃	

(2)This packaged air conditioner is manufactured and tested in conformity with the following standard.
JIS B8616"UNITARY AIR CONDITIONERS"

(3)Canvas panel is used in combination with following canvas duct
Canvas duct: HA01484

(4)The number "2", following the type of each model, represents "CE-marked model" especially for European Union, and for European nations which require CE marking.

(5)Add the canvas duct length to the unit height for the canvas type.

(e) Satellite ducted type (FDUM)
Models FDUM321HKXE2, 401HKXE2

Item	Models	FDUM321HKXE2 ⁽³⁾		FDUM401HKXE2 ⁽³⁾	
Nominal cooling capacity* ¹	W	3600		4500	
Nominal heating capacity* ²	W	4000		5000	
Power source		1 Phase 220/240V 50Hz			
Noise level	dB(A)	Hi: 34 Me: 32 Lo: 29		Hi: 35 Me: 32 Lo: 29	
Exterior dimensions Height × Width × Depth	mm	299 × 750 × 635			
Net weight	kg	34			
Refrigerant equipment Heat exchanger		Louver fins & inner grooved tubing			
Refrigerant control		Electronic Expansion Valve +Capillary tube			
Refrigerant		R22			
Quantity	kg	—			
Air handling equipment Fan type & Q'ty		Centrifugal fan × 2			
Motor	W	50×1		55×1	
Starting method		Line starting			
Air flow(Standard)	CMM	Hi: 12 Me: 11 Lo: 10		Hi: 14 Me: 12 Lo: 11	
Available static pressure (at Me)	mmAq	Standard:5, Hi speed:8.5			
Fresh air intake		Side			
Air filter, Q'ty		—			
Shock & vibration absorber		Rubber sleeve(for fan motor)			
Insulation (noise & heat)		Polyurethane foam			
Operation control Operation switch		Remote control switch (Optional:RC-HKXR-SN8-E2)			
Room temperature control		Thermostat by electronics			
Safety equipment		Internal thermostat for fan motor. Frost protection thermostat			
Installation data Refrigerant piping size	mm(in)	Liquid line:φ6.35(1/4"),Gas line:φ12.7(1/2")			
Connecting method		Flare piping			
Drain hose		Connectable with VP25			
Insulation for piping		Necessary (both Liquid & Gas lines)			
Accessories		Mounting kit			
Optional parts		—			
Outdoor units to be combined		FDC2001HKXRE2, 2501HKXRE2			

Notes (1) The data are measured at the following conditions.

Item	Indoor air temperature		Outdoor air temperature		Standards
	DB	WB	DB	WB	
Cooling* ¹	27℃	19℃	35℃	24℃	ISO-A,JIS B8616
Heating* ²	20℃	—	7℃	6℃	

(2) This packaged air conditioner is manufactured and tested in conformity with the following standard.
JIS B8616"UNITARY AIR CONDITIONERS"

(3) The number "2", following the type of each model, represents"CE-marked model" especially for European Union, and for European nations which require CE marking.

Models FDUM501HKXE2, 631HKXE2, 801HKXE2

Item	Models		FDUM501HKXE2 ⁽³⁾	FDUM631HKXE2 ⁽³⁾	FDUM801HKXE2 ⁽³⁾
	Nominal cooling capacity* ¹	W	5600	7100	9000
Nominal heating capacity* ²	W	6300	8000	10000	
Power source		1 Phase 220/240V 50Hz			
Noise level	dB(A)	Hi: 35 Me: 32 Lo: 29	Hi: 35 Me: 32 Lo: 29	Hi: 36 Me: 33 Lo: 30	
Exterior dimensions Height × Width × Depth	mm	299 × 750 × 635	299 × 950 × 635		
Net weight	kg	34	40		
Refrigerant equipment Heat exchanger		Louver fins & inner grooved tubing			
Refrigerant control		Electronic Expansion Valve +Capillary tube			
Refrigerant		R22			
Quantity	kg	—			
Air handling equipment Fan type & Q'ty		Centrifugal fan × 2			
Motor	W	55 × 1	90 × 1	100 × 1	
Starting method		Line starting			
Air flow(Standard)	CMM	Hi: 14 Me: 12 Lo: 11	Hi: 18 Me: 16 Lo: 14	Hi: 20 Me: 18 Lo: 15	
Available static pressure (at Me)	mmAq	Standard:5, Hi speed:8.5			
Fresh air intake		Side			
Air filter, Q'ty		—			
Shock & vibration absorber		Rubber sleeve(for fan motor)			
Insulation (noise & heat)		Polyurethane foam			
Operation control Operation switch		Remote control switch (Optional:RC-HKXR-SN8-E2)			
Room temperature control		Thermostat by electronics			
Safety equipment		Internal thermostat for fan motor. Frost protection thermostat			
Installation data Refrigerant piping size	mm(in)	Liquid line:φ9.52(3/8"),Gas line:φ15.88(5/8")			
Connecting method		Flare piping			
Drain hose		Connectable with VP25			
Insulation for piping		Necessary (both Liquid & Gas lines)			
Accessories		Mounting kit			
Optional parts		—			
Outdoor units to be combined		FDC2001HKXRE2, 2501HKXRE2			

Notes (1) The data are measured at the following conditions.

Item	Indoor air temperature		Outdoor air temperature		Standards
	DB	WB	DB	WB	
Operation Cooling* ¹	27℃	19℃	35℃	24℃	ISO-A,JIS B8616
Heating* ²	20℃	—	7℃	6℃	

(2) This packaged air conditioner is manufactured and tested in conformity with the following standard.
JIS B8616"UNITARY AIR CONDITIONERS"

(3) The number "2", following the type of each model, represents"CE-marked model" especially for European Union, and for European nations which require CE marking.

Models FDUM1001HKXE2, 1251HKXE2

Item	Models		FDUM1001HKXE2 ⁽³⁾	FDUM1251HKXE2 ⁽³⁾
Nominal cooling capacity* ¹	W		11200	14000
Nominal heating capacity* ²	W		12500	16000
Power source			1 Phase 220/240V 50Hz	
Noise level	dB(A)		Hi: 38 Me: 35 Lo: 32	Hi: 39 Me: 37 Lo: 34
Exterior dimensions Height × Width × Depth	mm		350 × 1370 × 635	
Net weight	kg		57	59
Refrigerant equipment Heat exchanger			Louver fins & inner grooved tubing	
Refrigerant control			Electronic Expansion Valve +Capillary tube	
Refrigerant			R22	
Quantity	kg		—	
Air handling equipment Fan type & Q'ty			Centrifugal fan × 3	
Motor	W		45 × 1, 90 × 1	50 × 1, 100 × 1
Starting method			Line starting	
Air flow(Standard)	CMM		Hi: 28 Me: 25 Lo: 22	Hi: 34 Me: 31 Lo: 27
Available static pressure (at Me)	mmAq		Standard:6, Hi speed:9	Standard:6, Hi speed:8.5
Fresh air intake			Side	
Air filter, Q'ty			—	
Shock & vibration absorber			Rubber sleeve(for fan motor)	
Insulation (noise & heat)			Polyurethane foam	
Operation control Operation switch			Remote control switch (Optional:RC-HKXR-SN8-E2)	
Room temperature control			Thermostat by electronics	
Safety equipment			Internal thermostat for fan motor. Frost protection thermostat	
Installation data Refrigerant piping size	mm(in)		Liquid line:φ9.52(3/8"),Gas line:φ19.05(3/4")	
Connecting method			Flare piping	
Drain hose			Connectable with VP25	
Insulation for piping			Necessary (both Liquid & Gas lines)	
Accessories			Mounting kit	
Optional parts			—	
Outdoor units to be combined			FDC2001HKXRE2, 2501HKXRE2	

Notes (1) The data are measured at the following conditions.

Operation	Item	Indoor air temperature		Outdoor air temperature		Standards
		DB	WB	DB	WB	
Cooling* ¹		27℃	19℃	35℃	24℃	ISO-A,JIS B8616
Heating* ²		20℃	—	7℃	6℃	

(2) This packaged air conditioner is manufactured and tested in conformity with the following standard.
JIS B8616"UNITARY AIR CONDITIONERS"

(3) The number "2", following the type of each model, represents"CE-marked model" especially for European Union, and for European nations which require CE marking.

(f) Ceiling suspension type (FDE)

Models FDE321HKXE2, 401HKXE2

Item	Models		FDE321HKXE2 ⁽³⁾	FDE401HKXE2 ⁽³⁾
Nominal cooling capacity* ¹	W		3600	4500
Nominal heating capacity* ²	W		4000	5000
Power source			1 Phase 220/240V 50Hz	
Noise level	dB(A)		Hi: 43 Me:40 Lo: 38	
Exterior dimensions Height × Width × Depth	mm		184 × 1000 × 650 + 240	
Net weight	kg		22	
Refrigerant equipment Heat exchanger			Louver fins & inner grooved tubing	
Refrigerant control			Electronic Expansion Valve + Capillary tube	
Refrigerant			R22	
Quantity	kg		—	
Air handling equipment Fan type & Q'ty			Centrifugal fan × 2	
Motor	W		40 × 1	
Starting method			Line starting	
Air flow(Standard)	CMM		Hi: 14 Me: 12 Lo: 10	
Fresh air intake			Not possible	
Air filter, Q'ty			Polypropylene net × 2(Washable)	
Shock & vibration absorber			Rubber sleeve(for fan motor)	
Insulation (noise & heat)			Polyurethane foam	
Operation control Operation switch			Remote control switch (Optional:RC-HKXR-SA8-E2)	
Room temperature control			Thermostat by electronics	
Safety equipment			Internal thermostat for fan motor. Frost protection thermostat	
Installation data Refrigerant piping size	mm(in)		Liquid line: φ 6.35(1/4"), Gas line: φ 12.7(1/2")	
Connecting method			Flare piping	
Drain hose			Connectable with VP20	
Insulation for piping			Necessary (both Liquid & Gas lines)	
Accessories			Mounting kit	
Optional parts			—	
Outdoor units to be combined			FDC2001HKXRE2, 2501HKXRE2	

Notes (1) The data are measured at the following conditions.

Item	Indoor air temperature		Outdoor air temperature		Standards
	DB	WB	DB	WB	
Operation					
Cooling* ¹	27℃	19℃	35℃	24℃	ISO-A, JIS B8616
Heating* ²	20℃	—	7℃	6℃	

(2) This packaged air conditioner is manufactured and tested in conformity with the following standard.

JIS B8616"UNITARY AIR CONDITIONERS"

(3) The number "2", following the type of each model, represents "CE-marked model" especially for European Union, and for European nations which require CE marking.

Models FDE501HKXE2, 631HKXE2

Item	Models		FDE501HKXE2 ⁽³⁾	FDE631HKXE2 ⁽³⁾
	Nominal cooling capacity* ¹	W	5600	7100
Nominal heating capacity* ²	W	6300	8000	
Power source		1 Phase 220/240V 50Hz		
Noise level	dB(A)	Hi: 43 Me:40 Lo: 38	Hi: 44 Me:40 Lo: 38	
Exterior dimensions Height × Width × Depth	mm	184 × 1000 × 650 + 240	184 × 1260 × 650 + 240	
Net weight	kg	22	27	
Refrigerant equipment Heat exchanger		Louver fins & inner grooved tubing		
Refrigerant control		Electronic Expansion Valve + Capillary tube		
Refrigerant		R22		
Quantity	kg	—		
Air handling equipment Fan type & Q'ty		Centrifugal fan × 2	Centrifugal fan × 4	
Motor	W	40 × 1	25 × 2	
Starting method		Line starting		
Air flow(Standard)	CMM	Hi: 14 Me: 12 Lo: 10	Hi: 18 Me: 15 Lo: 12	
Fresh air intake		Not possible		
Air filter, Q'ty		Polypropylene net × 2(Washable)		
Shock & vibration absorber		Rubber sleeve(for fan motor)		
Insulation (noise & heat)		Polyurethane foam		
Operation control Operation switch		Remote control switch (Optional:RC-HKXR-SA8-E2)		
Room temperature control		Thermostat by electronics		
Safety equipment		Internal thermostat for fan motor. Frost protection thermostat		
Installation data Refrigerant piping size	mm(in)	Liquid line: φ9.52(3/8"), Gas line: φ15.88(5/8")		
Connecting method		Flare piping		
Drain hose		Connectable with VP20		
Insulation for piping		Necessary (both Liquid & Gas lines)		
Accessories		Mounting kit		
Optional parts		—		
Outdoor units to be combined		FDC2001HKXRE2, 2501HKXRE2		

Notes (1) The data are measured at the following conditions.

Item	Indoor air temperature		Outdoor air temperature		Standards
	DB	WB	DB	WB	
Operation Cooling* ¹	27℃	19℃	35℃	24℃	ISO-A, JIS B8616
Heating* ²	20℃	—	7℃	6℃	

(2) This packaged air conditioner is manufactured and tested in conformity with the following standard.
JIS B8616"UNITARY AIR CONDITIONERS"

(3) The number "2", following the type of each model, represents"CE-marked model" especially for European Union, and for European nations which require CE marking.

Models FDE1001HKXE2, 1251HKXE2

Item	Models		FDE1001HKXE2 ⁽³⁾	FDE1251HKXE2 ⁽³⁾
	W			
Nominal cooling capacity* ¹	W		11200	14000
Nominal heating capacity* ²	W		12500	16000
Power source			1 Phase 220/240V 50Hz	
Noise level	dB(A)		Hi: 49 Me:46 Lo: 42	Hi: 50 Me:47 Lo: 42
Exterior dimensions Height × Width × Depth	mm		239 × 1260 × 650 + 240	239 × 1470 × 650 + 240
Net weight	kg		34	40
Refrigerant equipment Heat exchanger			Louver fins & inner grooved tubing	
Refrigerant control			Electronic Expansion Valve +Capillary tube	
Refrigerant			R22	
Quantity	kg		—	
Air handling equipment Fan type & Q'ty			Centrifugal fan × 3	Centrifugal fan × 4
Motor	W		35×1 + 55×1	55×2
Starting method			Line starting	
Air flow(Standard)	CMM		Hi: 28 Me: 25 Lo: 22	Hi: 34 Me: 30 Lo: 26
Fresh air intake			Not possible	
Air filter, Q'ty			Polypropylene net × 2(Washable)	
Shock & vibration absorber			Rubber sleeve(for fan motor)	
Insulation (noise & heat)			Polyurethane foam	
Operation control Operation switch			Remote control switch (Optional:RC-HKXR-SA8-E2)	
Room temperature control			Thermostat by electronics	
Safety equipment			Internal thermostat for fan motor. Frost protection thermostat	
Installation data Refrigerant piping size	mm(in)		Liquid line:φ9.52(3/8"), Gas line:φ15.88(5/8")	
Connecting method			Flare piping	
Drain hose			Connectable with VP20	
Insulation for piping			Necessary (both Liquid & Gas lines)	
Accessories			Mounting kit	
Optional parts			—	
Outdoor units to be combined			FDC2001HKXRE2, 2501HKXRE2	

Notes (1) The data are measured at the following conditions.

Item	Indoor air temperature		Outdoor air temperature		Standards
	DB	WB	DB	WB	
Operation Cooling* ¹	27℃	19℃	35℃	24℃	ISO-A,JIS B8616
Heating* ²	20℃	—	7℃	6℃	

(2) This packaged air conditioner is manufactured and tested in conformity with the following standard.
JIS B8616"UNITARY AIR CONDITIONERS"

(3) The number "2", following the type of each model, represents"CE-marked model" especially for European Union, and for European nations which require CE marking.

(g) Wall mounted type (FDKY)

Models FDKY251HKXE2, 321HKXE2, 401HKXE2

Item	Models		
	FDKY251HKXE2 ⁽³⁾	FDKY321HKXE2 ⁽³⁾	FDKY401HKXE2 ⁽³⁾
Nominal cooling capacity* ¹	W	2800	3600
Nominal heating capacity* ²	W	3200	4000
Power source		1 Phase 220/240V 50Hz	
Noise level	dB(A)	Hi: 42 Me:40 Lo: 37	Hi: 44 Me:41 Lo: 37
Exterior dimensions Height × Width × Depth	mm	375 × 930 × 194	
Net weight	kg	19	
Refrigerant equipment Heat exchanger		Louver fins & inner grooved tubing	
Refrigerant control		Electronic Expansion Valve + Capillary tube	
Refrigerant		R22	
Quantity	kg	—	
Air handling equipment Fan type & Q'ty		Centrifugal fan × 2	
Motor	W	30 × 1	35 × 1
Starting method		Line starting	
Air flow(Standard)	CMM	Hi: 10 Me: 9 Lo: 8	Hi: 11.5 Me: 10 Lo: 8
Fresh air intake		Not possible	
Air filter, Q'ty		Polypropylene net × 2(Washable)	
Shock & vibration absorber		Rubber sleeve(for fan motor)	
Insulation (noise & heat)		Polyurethane foam	
Operation control Operation switch		Remote control switch (Optional:RC-HKXR-SA8-E2)	
Room temperature control		Thermostat by electronics	
Safety equipment		Internal thermostat for fan motor. Frost protection thermostat	
Installation data Refrigerant piping size	mm(in)	Liquid line: φ 6.35(1/4"), Gas line: φ 12.7(1/2")	
Connecting method		Flare piping	
Drain hose		Connectable with I.D. 16mm	
Insulation for piping		Necessary (both Liquid & Gas lines)	
Accessories		Mounting kit	
Optional parts		—	
Outdoor units to be combined		FDC2001HKXRE2, 2501HKXRE2	

Notes (1) The data are measured at the following conditions.

Item	Indoor air temperature		Outdoor air temperature		Standards
	DB	WB	DB	WB	
Operation					
Cooling* ¹	27℃	19℃	35℃	24℃	ISO-A, JIS B8616
Heating* ²	20℃	—	7℃	6℃	

(2) This packaged air conditioner is manufactured and tested in conformity with the following standard.

JIS B8616"UNITARY AIR CONDITIONERS"

(3) The number "2", following the type of each model, represents "CE-marked model" especially for European Union, and for European nations which require CE marking.

Models FDKY501HKXE2, 631HKXE2

Item	Model	FDKY501HKXE2 ⁽³⁾	FDKY631HKXE2 ⁽³⁾
Nominal cooling capacity* ¹	W	5600	7100
Nominal heating capacity* ²	W	6300	8000
Power source		1 Phase 220/240V 50Hz	
Noise level	dB(A)	Hi: 46 Me:43 Lo: 39	Hi: 47 Me:44 Lo: 40
Exterior dimensions Height × Width × Depth	mm	375 × 1148 × 194	375 × 1436 × 194
Net weight	kg	20	22
Refrigerant equipment Heat exchanger		Louver fins & inner grooved tubing	
Refrigerant control		Electronic Expansion Valve + Capillary tube	
Refrigerant		R22	
Quantity	kg	—	
Air handling equipment Fan type & Q'ty		Tangential fan × 1	Tangential fan × 2
Motor	W	40 × 1	45 × 1
Starting method		Line starting	
Air flow(Standard)	CMM	Hi: 17 Me: 15 Lo: 13	Hi: 21 Me: 18 Lo: 15
Fresh air intake		Not possible	
Air filter, Q'ty		Polypropylene net × 2(Washable)	
Shock & vibration absorber		Rubber sleeve(for fan motor)	
Insulation (noise & heat)		Polyurethane foam	
Operation control Operation switch		Remote control switch (Optional:RC-HKXR-SA8-E2)	
Room temperature control		Thermostat by electronics	
Safety equipment		Internal thermostat for fan motor. Frost protection thermostat	
Installation data Refrigerant piping size	mm(in)	Liquid line:φ 9.52(3/8"), Gas line:φ 15.88(5/8")	
Connecting method		Flare piping	
Drain hose		Connectable with I.D. 16mm	
Insulation for piping		Necessary (both Liquid & Gas lines)	
Accessories		Mounting kit	
Optional parts		—	
Outdoor units to be combined		FDC2001HKXRE2, 2501HKXRE2	

Notes (1) The data are measured at the following conditions.

Item	Indoor air temperature		Outdoor air temperature		Standards
	DB	WB	DB	WB	
Cooling* ¹	27℃	19℃	35℃	24℃	ISO-A, JIS B8616
Heating* ²	20℃	—	7℃	6℃	

(2) This packaged air conditioner is manufactured and tested in conformity with the following standard.
JIS B8616"UNITARY AIR CONDITIONERS"

(3) The number "2", following the type of each model, represents"CE-marked model" especially for European Union, and for European nations which require CE marking.

(h) Floor standing type (FDL)

Models FDFL251HKXE2, 401HKXE2, 631HKXE2

Item	Model	FDFL251HKXE2 ⁽³⁾	FDFL401HKXE2 ⁽³⁾	FDFL631HKXE2 ⁽³⁾
Nominal cooling capacity* ¹	W	2800	4500	7100
Nominal heating capacity* ²	W	3200	5000	8000
Power source		1 Phase 220/240V 50Hz		
Noise level	dB(A)	Hi: 41 Me:38 Lo: 36	Hi: 43 Me:41 Lo: 40	
Exterior dimensions Height × Width × Depth	mm	630 × 1196 × 225		630 × 1481 × 225
Net weight	kg	32		40
Refrigerant equipment Heat exchanger		Louver fins & inner grooved tubing		
Refrigerant control		Electronic Expansion Valve + Capillary tube		
Refrigerant		R22		
Quantity	kg	—		
Air handling equipment Fan type & Q'ty		Centrifugal fan × 2		
Motor	W	30 × 1	40 × 1	
Starting method		Line starting		
Air flow(Standard)	CMM	Hi: 12 Me: 11 Lo: 10	Hi: 14 Me: 12 Lo: 10	Hi: 18 Me: 15 Lo: 12
Fresh air intake		Not possible		
Air filter, Q'ty		Polypropylene net × 2(Washable)		
Shock & vibration absorber		Rubber sleeve(for fan motor)		
Insulation (noise & heat)		Polyurethane foam		
Operation control Operation switch		Remote control switch (Optional:RC-HKXR-SN8-E2)		
Room temperature control		Thermostat by electronics		
Safety equipment		Internal thermostat for fan motor. Frost protection thermostat		
Installation data Refrigerant piping size	mm(in)	Liquid line:φ 6.35(1/4"), Gas line:φ 12.7(1/2")		Liquid line:φ 9.52(3/8") Gas line:φ 15.88(5/8")
Connecting method		Flare piping		
Drain hose		Connectable with VP20		
Insulation for piping		Necessary (both Liquid & Gas lines)		
Accessories		Mounting kit		
Optional parts		—		
Outdoor units to be combined		FDC2001HKXRE2, 2501HKXRE2		

Notes (1) The data are measured at the following conditions.

Item	Indoor air temperature		Outdoor air temperature		Standards
	DB	WB	DB	WB	
Operation					
Cooling* ¹	27℃	19℃	35℃	24℃	ISO-A,JIS B8616
Heating* ²	20℃	—	7℃	6℃	

(2) This packaged air conditioner is manufactured and tested in conformity with the following standard.
JIS B8616"UNITARY AIR CONDITIONERS"

(3) The number "2", following the type of each model, represents"CE-marked model" especially for European Union, and for European nations which require CE marking.

(2) Outdoor unit

Models FDC2001HKXRE2, 2501HKXRE2

Item	Models	FDC2001HKXE2 ⁽³⁾	FDC2501HKXE2 ⁽³⁾
Power source		3 Phase 380/415V 50Hz	
Nominal cooling capacity*1	W	22400	28000
Nominal heating capacity*2	W	25000	31500
Noise level	dB(A)	60	
Exterior dimensions Height × Width × Depth	mm	1700 × 1350 × 600	
Net weight	kg	270	280
Refrigerant equipment compressor type & Q' ty		RS5555EAV31 × 1	RS5570EAV31 × 1
Motor	kW	5.5	7.5
Starting method		Direct start	
Capacity control	%	100 ~ 22.0	
Crankcase heater	W	40	
Heat exchanger		Louver fines & inner grooved tubing	
Refrigerant control		Expansion Valve +Capillary tube	
Refrigerant		R22	
Quantity	kg	11	
Refrigerant oil		2.5 (BARREL FREEZE 32SAM)	
Defrost control		MC controlled De-Icer	
Air handling equipment Fan type & Q'ty		Centrifugal fan × 2	
Motor	W	100 × 2	
Starting method		Direct start	
Air flow(Standard)	CMM	175	
Shock & vibration absorber		Rubber mount (for compressor)	
Safety equipment		Compressor overheat protection, overcurrent protection, power transformer overheating protection, abnormal high pressure protection	
Installation data Refrigerant piping size	mm(in)	Liquid line: φ12.7(1/2") Gas line: φ25.4(1")	Liquid line: φ12.7(1/2") Gas line: φ28.58(1 1/8")
Connecting method		Brazing	
Drain		Hole for drain(φ20 × 6pcs)	
Insulation for piping		Necessary (both Liquid & Gas lines)	
Accessories		Discharge gas side connection piping (for operation valve and back direction connections), intake gas side connection piping (for operation valve and back direction connections)	
Indoor units to be combined		FDT251, 321, 401, 501, 631, 801, 1001, 1251type FDTW251, 401, 501, 631, 801, 1001, 1251type FDTS251, 321, 401, 631type FDR201, 251, 401, 501, 631, 801, 1001, 1251type FDUM321, 401, 501, 631, 801, 1001, 1251type FDE321, 401, 501, 631, 1001, 1251type FDKY251, 321, 401, 501, 631type FDL251, 401, 631type	

Notes (1) The cooling and heating capabilities imply the values when the indoor unit of rated capacity is connected under the condition specified in JIS-B8616.

(2) The refrigerant quantity in the connecting pipe is not included Charge it additionally at the site.

(3) The number "2", following the type of each model, represents "CE-marked model" especially for European Union, and for European nations which require CE marking.

(4) When an individual flow divide controller is used a pipe part set is required.

Flow divide controller part No. list

Type	Part No.	Type	Part No.
	FDC2001,2501		FDC2001,2501
Individual flow divide controller	HPFD01R-E	For 3 pipes (for horizontal division)	DIS-IKXR3-E
		For 3 pipes (for vertical division)	DIS-VIKXR3-E

1.2 Range of usage & limitations

System		FDC2001HKXRE2	FDC2501HKXRE2
Item			
Indoor intake air temperature (Upper, lower limits)		Refer to the capacity characteristics.	
Outdoor air temperature (Upper, lower limits)			
Indoor units that can be used in combination	Number of connected units	1 to 8 units	
	Total capacity	11000 to 29200w	13200 to 37100w
Single direction piping length		Indoor unit MAX 100m	
Pipining length after first division		MAX 30m	
Difference in height between indoor and outdoor units	When above outdoor unit	MAX 50m	
	When below outdoor unit	MAX 20m	
Difference in height between indoor units		MAX 15m	
Indoor unit atmosphere (behind ceiling) temperature and humidity		Dew point temperature 28 °C or less, relative humidity 80% or less	
Compressor stop/start frequency	1 cycle time	6 min or more(from stop to stop or from start to start)	
	Stop time	3 min or more	
Power source voltage	Voltage fluctuation	Within $\pm 10\%$ of rated voltage	
	Voltage drop during start	Within $\pm 15\%$ of rated voltage	
	Interval unbalance	Within $\pm 3\%$ of rated voltage	

Allowable length of refrigerant piping, Height difference between indoor and outdoor unit

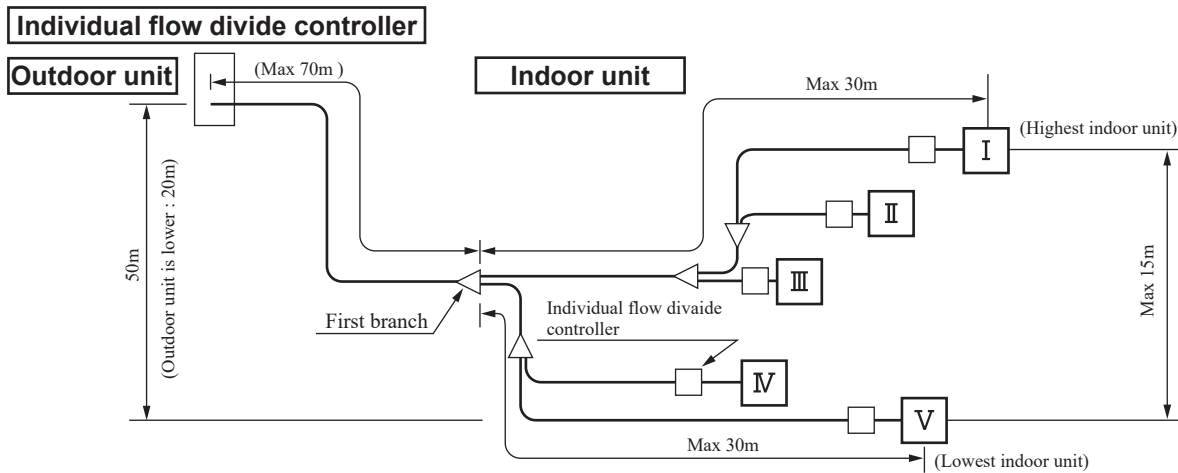

- Between the outdoor unit and first branch (main piping): Max 70m (actual length)
- Between the first branch and each indoor unit : Max 30m (each indoor unit) (actual length)

Note 1: The indoor unit and individual flow divide controller positions should be within the range of the reach of the connections of the wires that come with the individual flow divide controller

(1) INDOOR UNIT

FDT251HKXE2,321HKXE2,401HKXE2,501HKXE2,631HKXE2,801HKXE2

FDT1001HKXE2,1251HKXE2

FDTW251HKXE2,401HKXE2,501HKXE2 **FDTW**631HKXE2,801HKXE2

FDTW1001HKXE2,1251HKXE2

FDTs251HKXE2,321HKXE2,401HKXE2 **FDTs**631HKXE2

FDR201HKXE2 (Silent Panel) (Canvas Panel)

FDR251HKXE2,401HKXE2,501HKXE2 (Silent Panel) (Canvas Panel)

FDR631HKXE2,801HKXE2 (Silent Panel) (Canvas Panel)

FDR1001HKXE2,1251HKXE2 (Silent Panel) (Canvas Panel)

FDUM321HKXE2,401HKXE2,501HKXE2 **FDUM**631HKXE2,801HKXE2

FDUM1001HKXE2,1251HKXE2

FDE321HKXE2,401HKXE2,501HKXE2 **FDE**631HKXE2

FDE1001HKXE2 **FDE**1251HKXE2

FDKY251HKXE2,321HKXE2,401HKXE2 **FDKY**501HKXE2

FDKY631HKXE2 **FDFL**251HKXE2,401HKXE2,631HKXE2

(2) Remote controller (optional parts)

(3) Individual flow divide controller (Optional Part)

(4) OUTDOOR UNIT **FDC**2001HKXRE2,2501HKXRE2

1.3 Exterior dimensions

(1) Indoor unit

(a) Ceiling recessed type (FDT)

Models FDT251HKXE2,321HKXE2,401HKXE2,501HKXE2,631HKXE2,801HKXE2

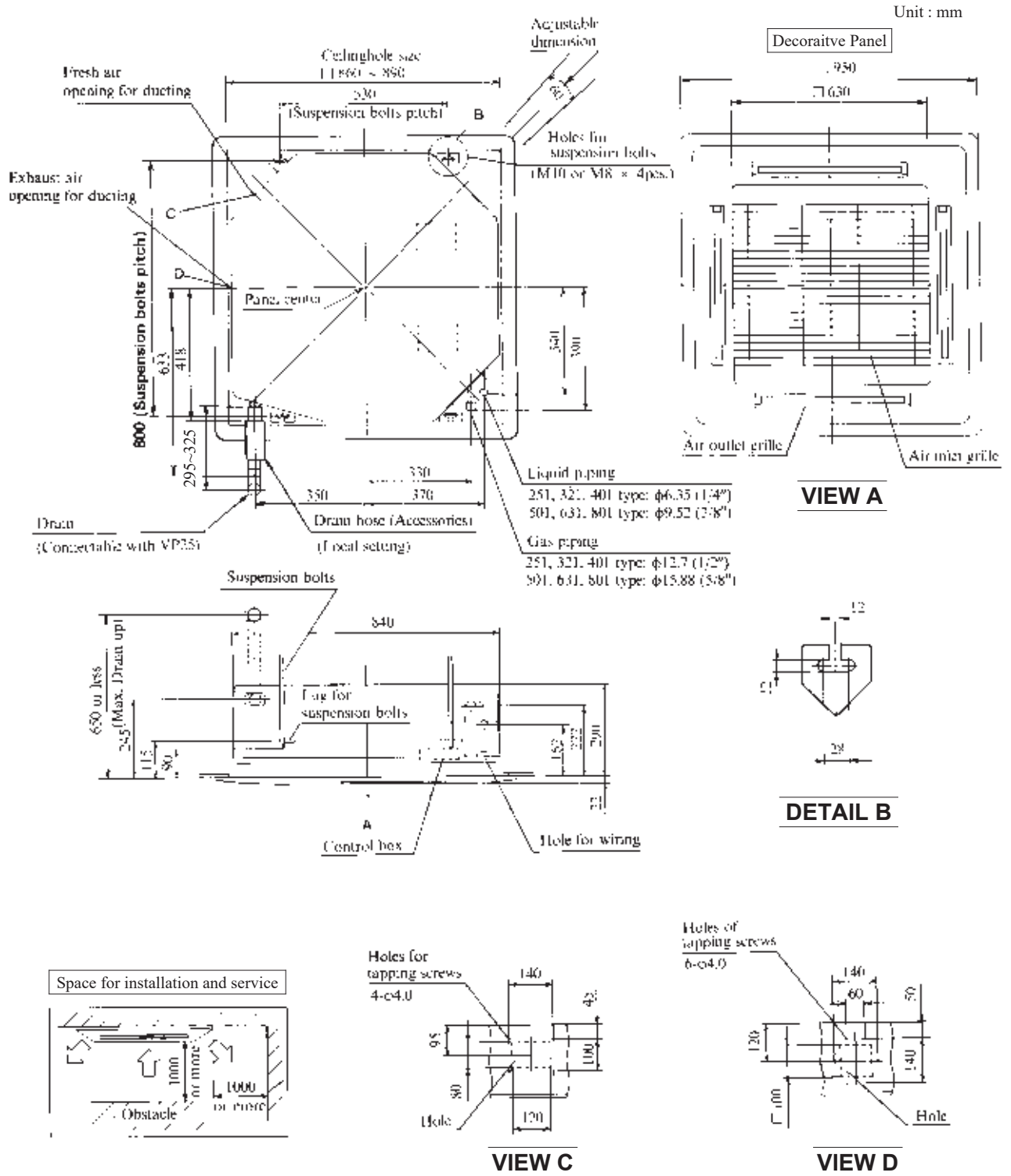

Models FDT1001HKXE2,1251HKXE2

Unit : mm

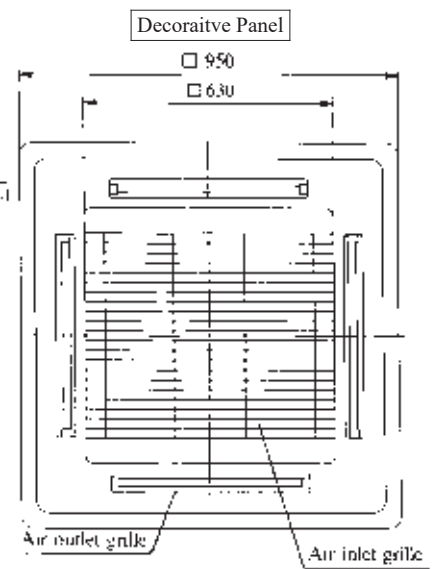
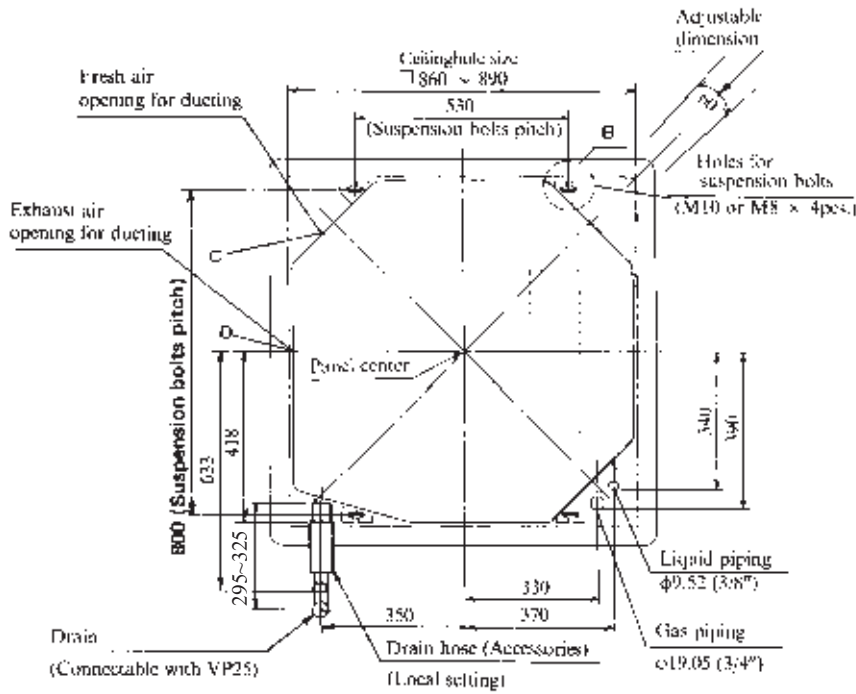

VIEW A

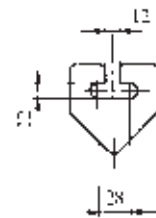
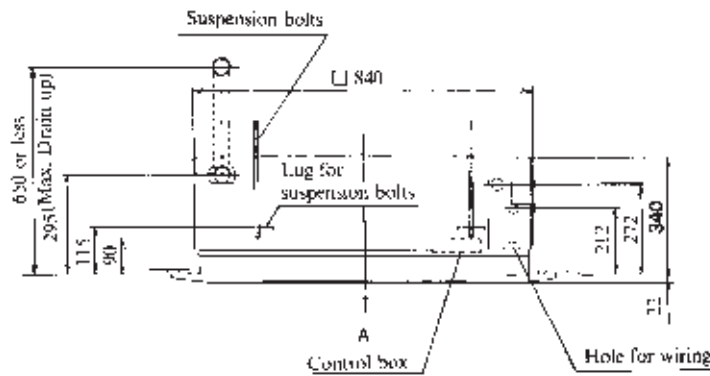

DETAIL B

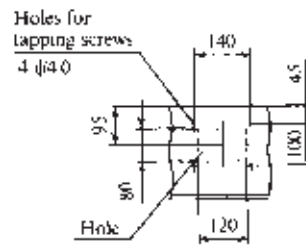
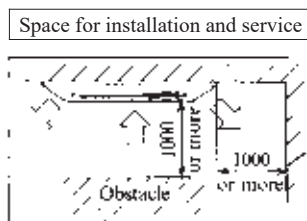

VIEW C

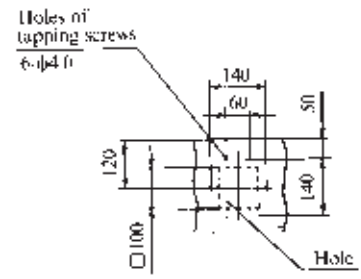

VIEW D

(b) 2-way outlet ceiling recessed type (FDTW)

Models FDTW251HKXE2,401HKXE2,501HKXE2

Unit : mm

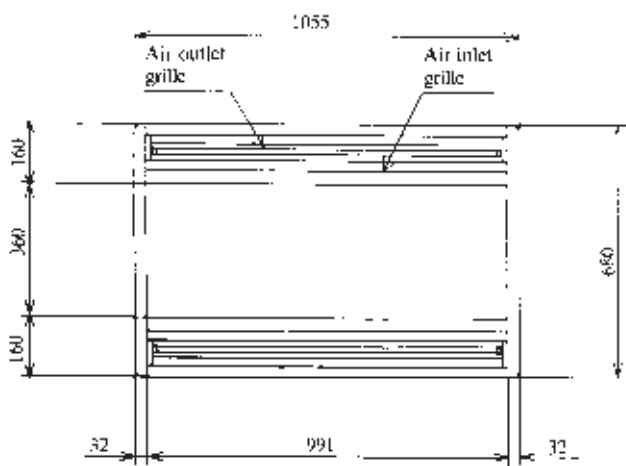
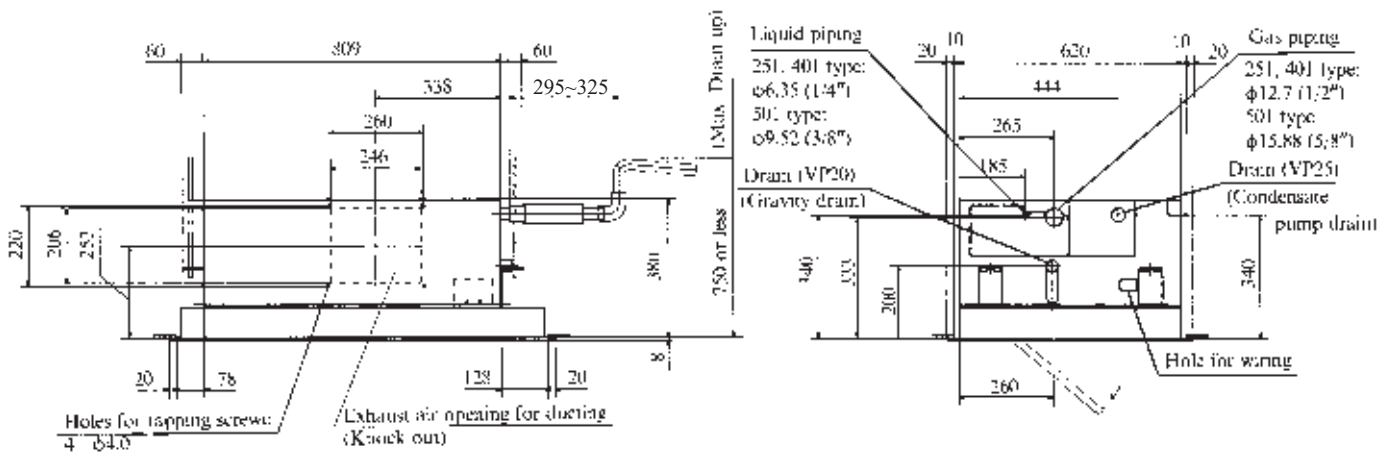
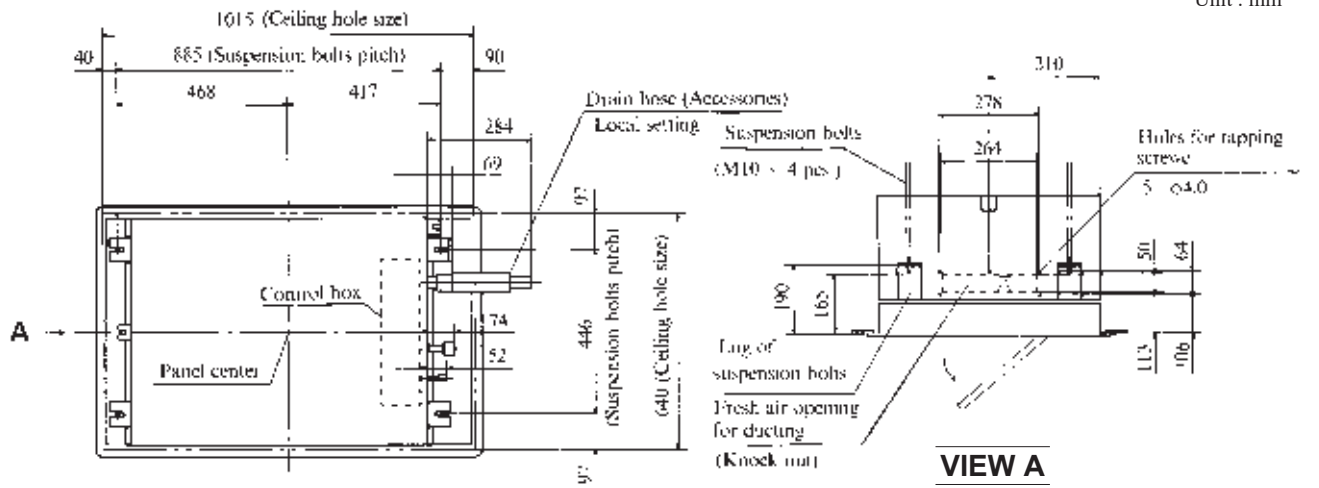

Decorative Panel

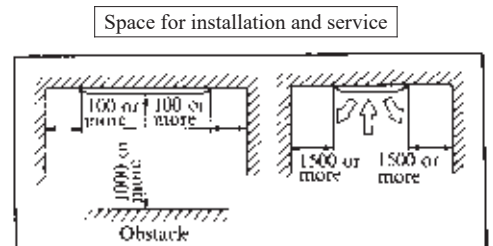

Models FDTW631HKXE2,801HKXE2

Unit : mm

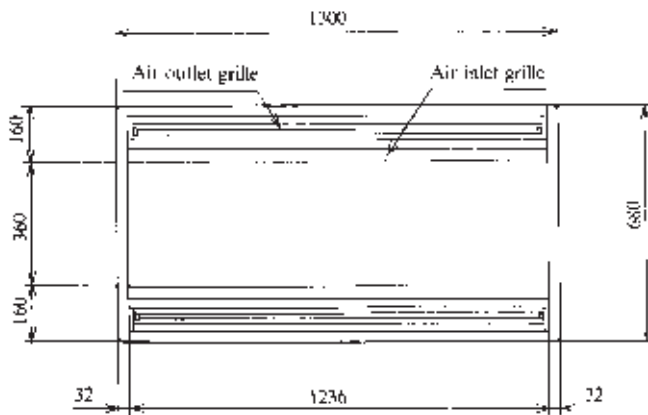
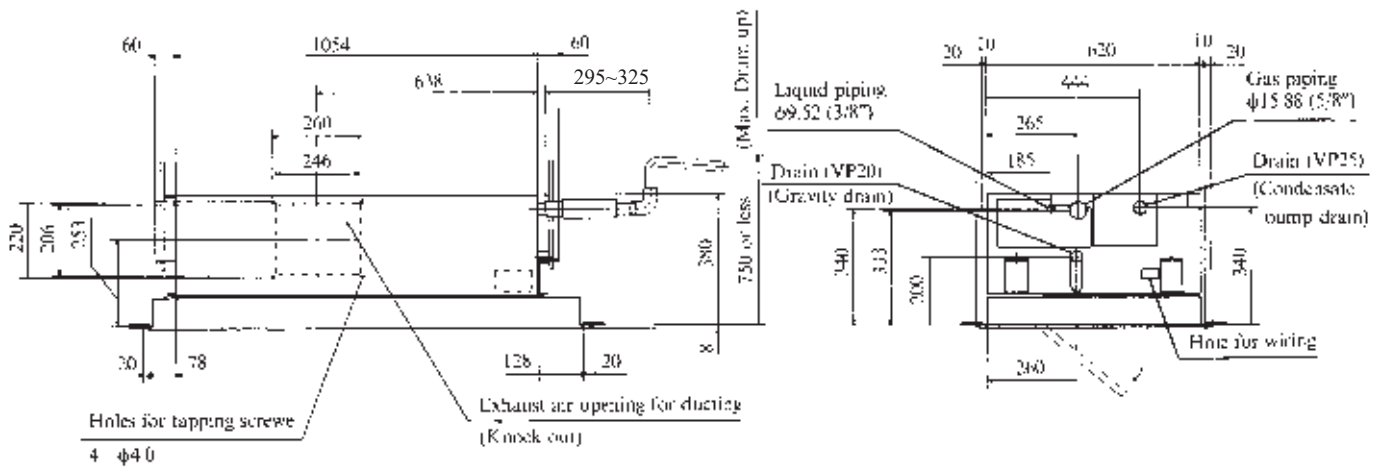
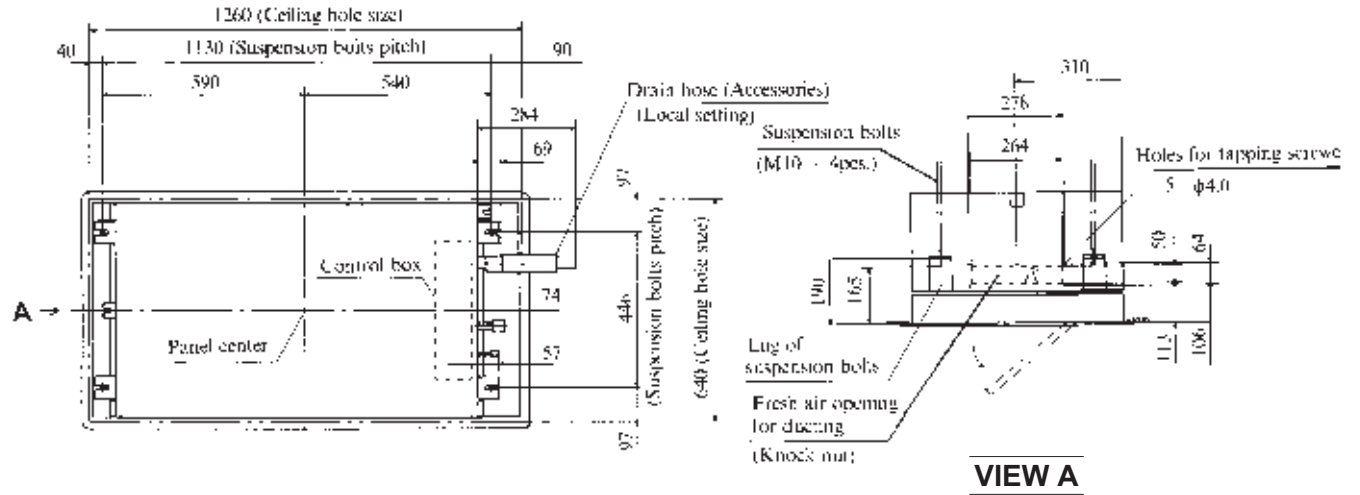

Decorative Panel

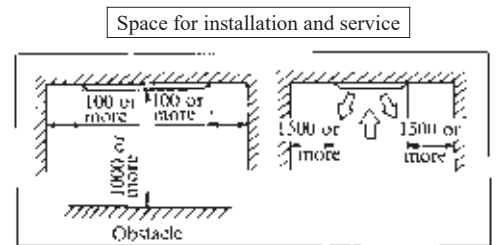

Models FDTW1001HKXE2,1251HKXE2

Unit : mm

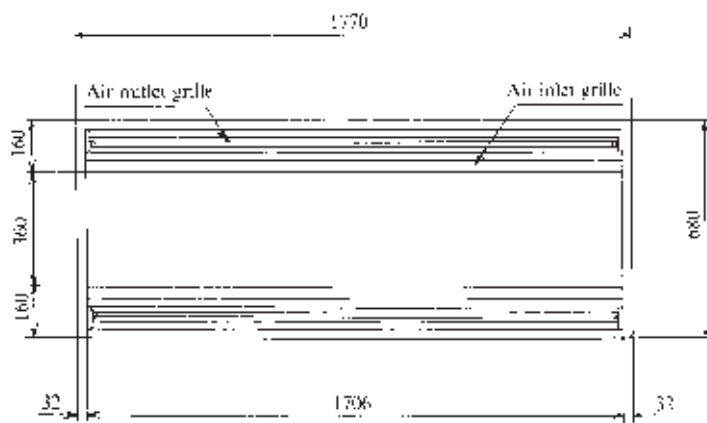
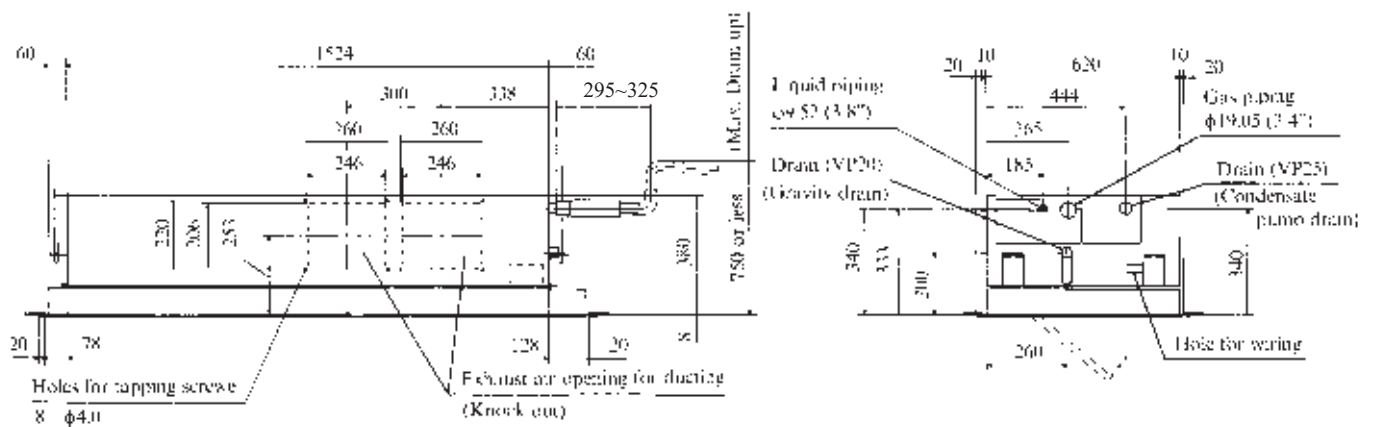
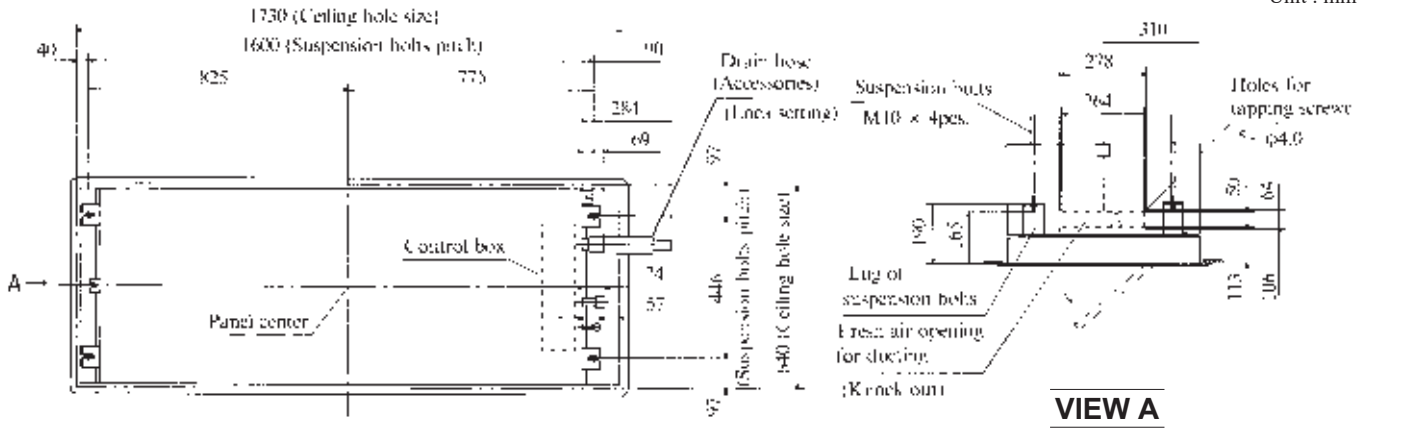

Decorative Panel

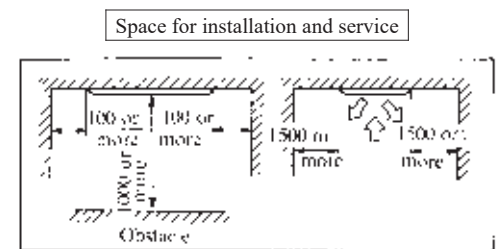

(c) 1-Way outlet ceiling recessed type (FDTS)

Models FDTS251HKXE2,321HKXE2,401HKXE2

Unit : mm

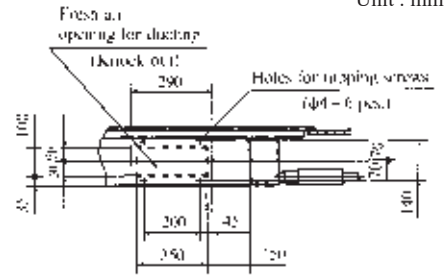
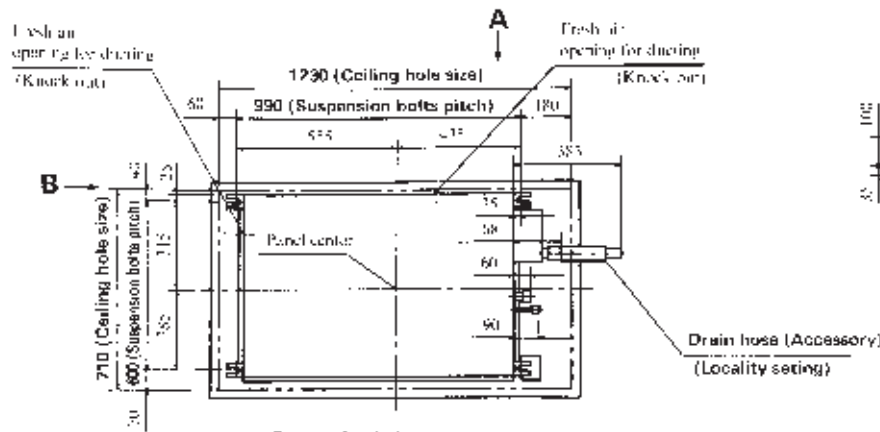

VIEW A

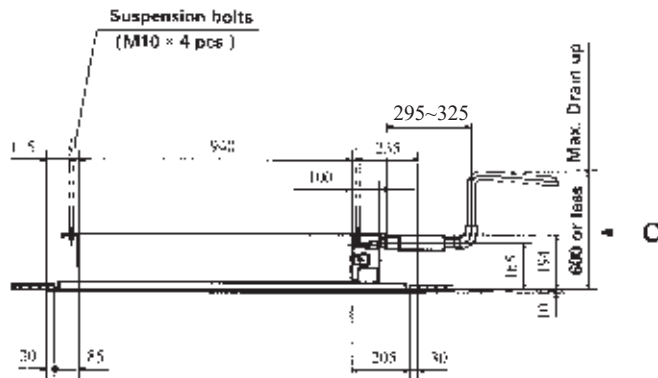

VIEW C

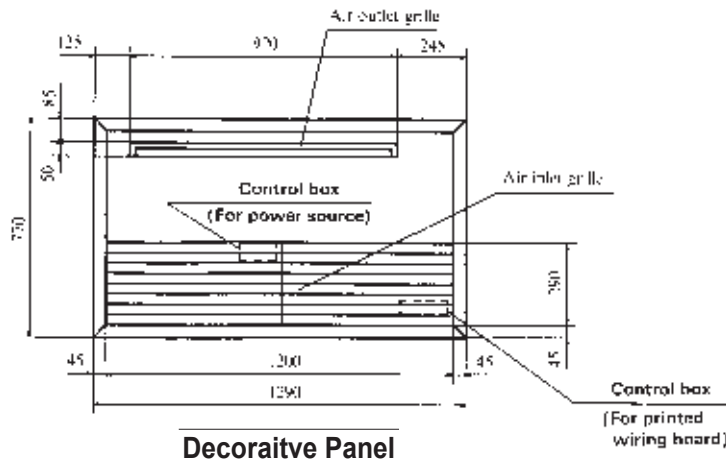

Decorative Panel

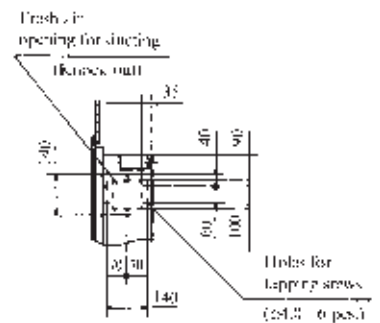

VIEW B

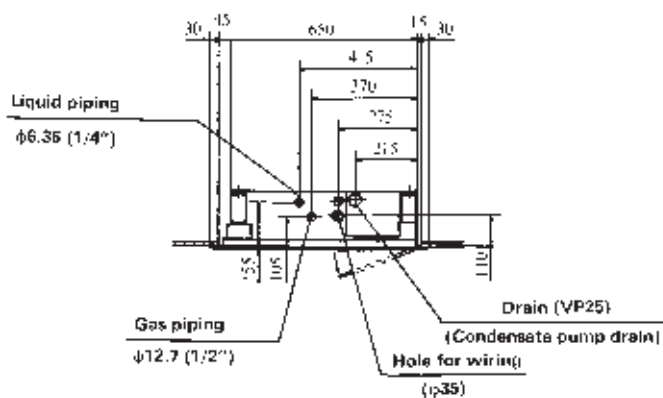

VIEW C

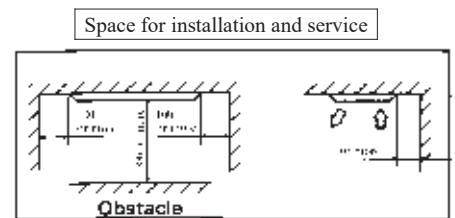

(d) Cassetteria type (FDR)

Model FDR201HKXE2

Quiet Panel (Model: R-PNLS-26W-E)

Unit : mm

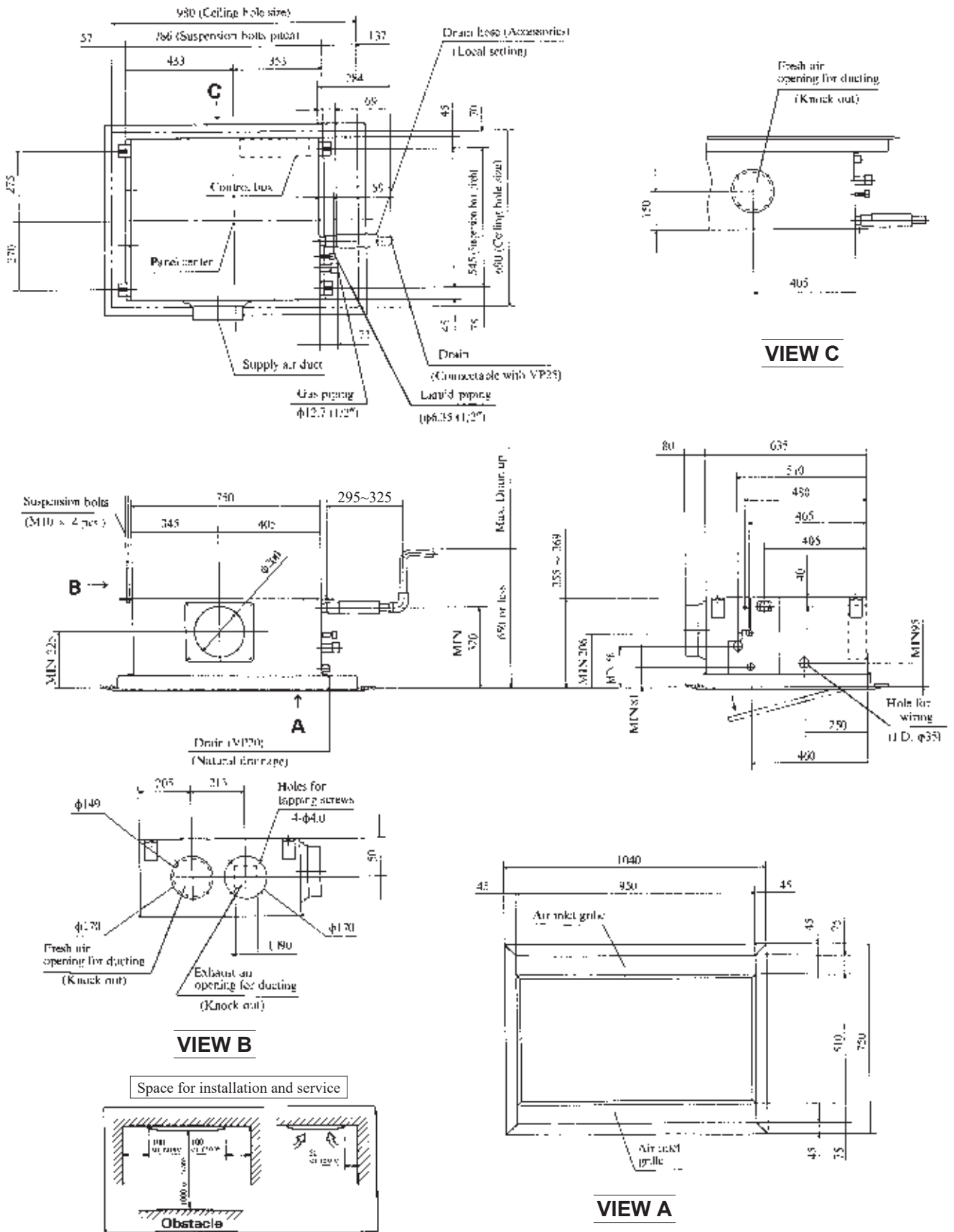

Canvas Panel (Model: R-PNLC-26W-E)

Unit : mm

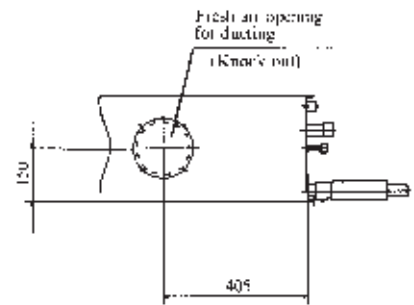
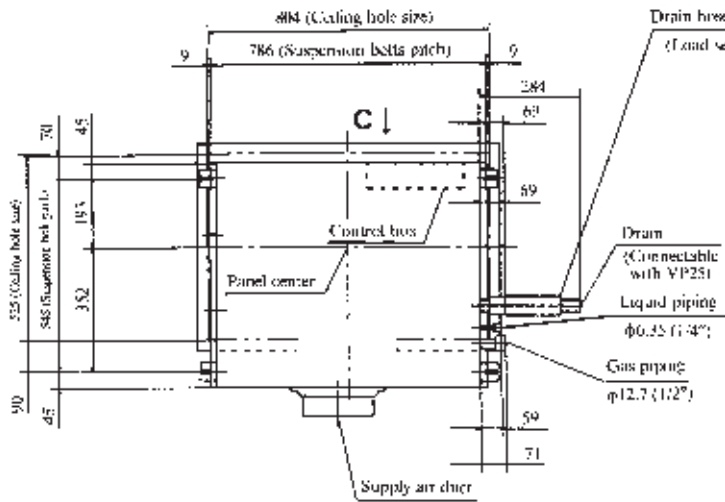

VIEW C

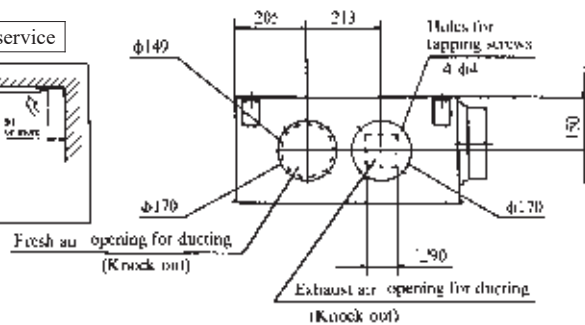
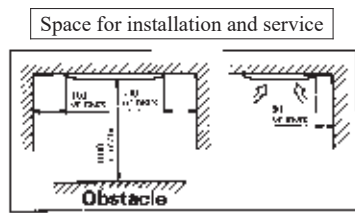
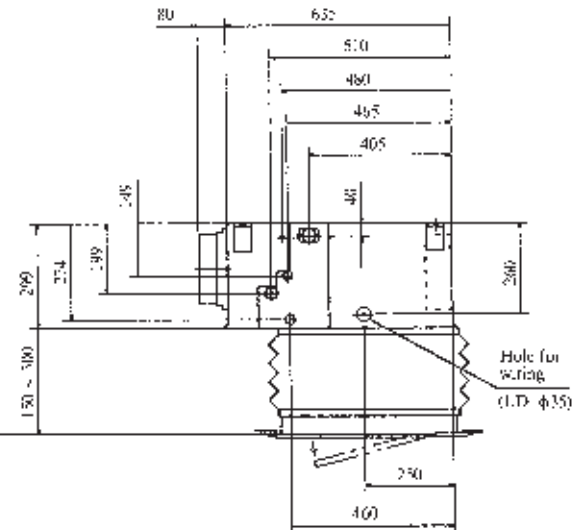
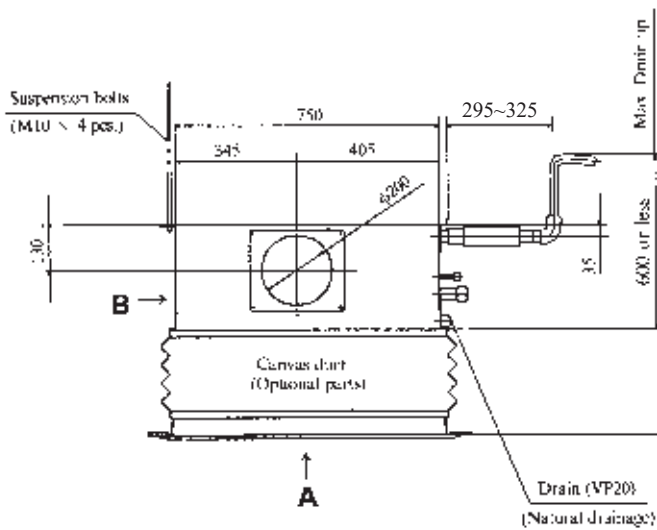

VIEW B

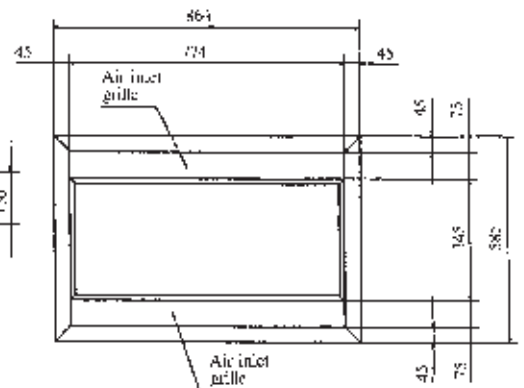

VIEW A

Models FDR251HKXE2, 401HKXE2, 501HKXE2

Quiet Panel (Model: R-PNLS-26W-E)

Unit : mm

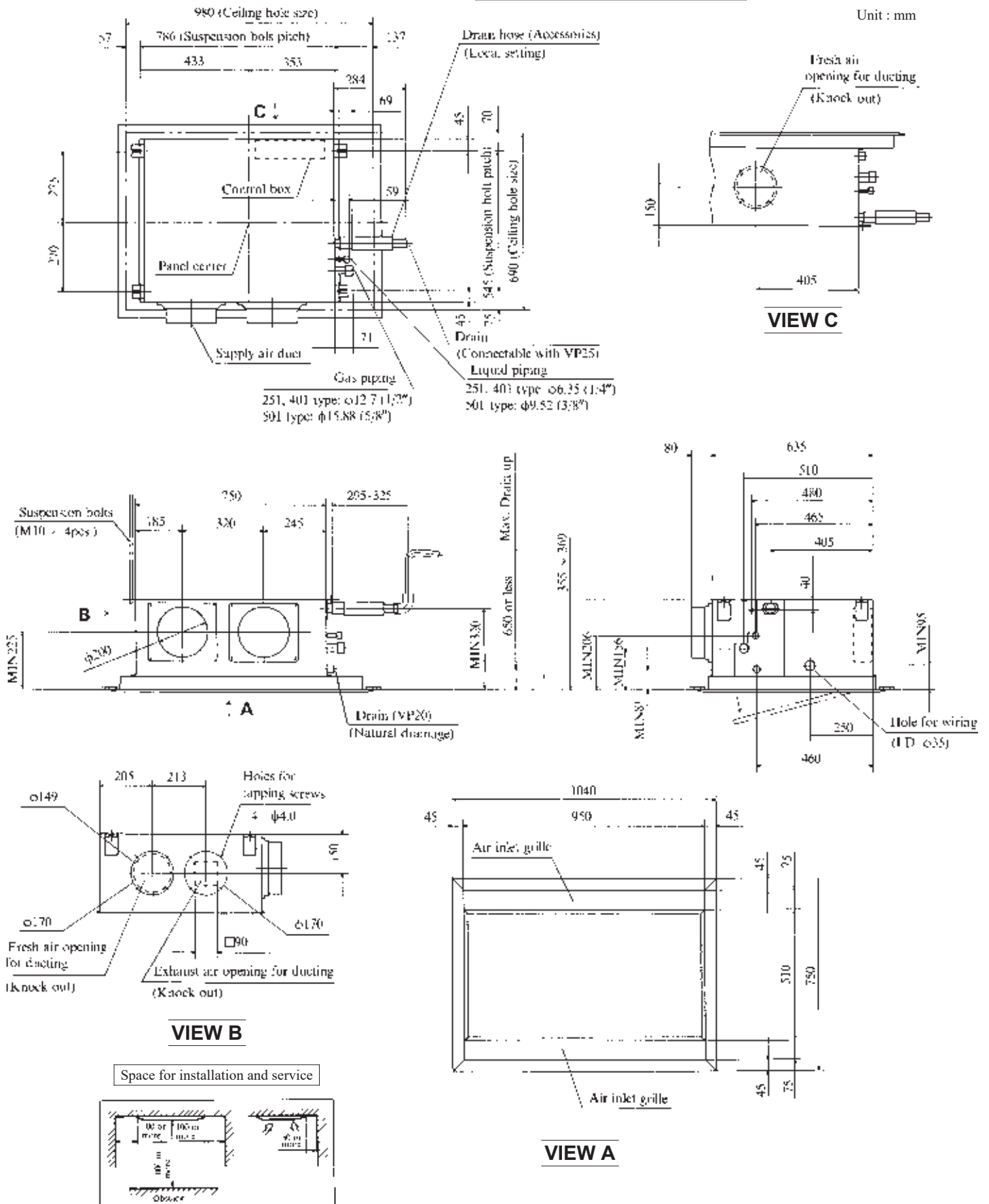

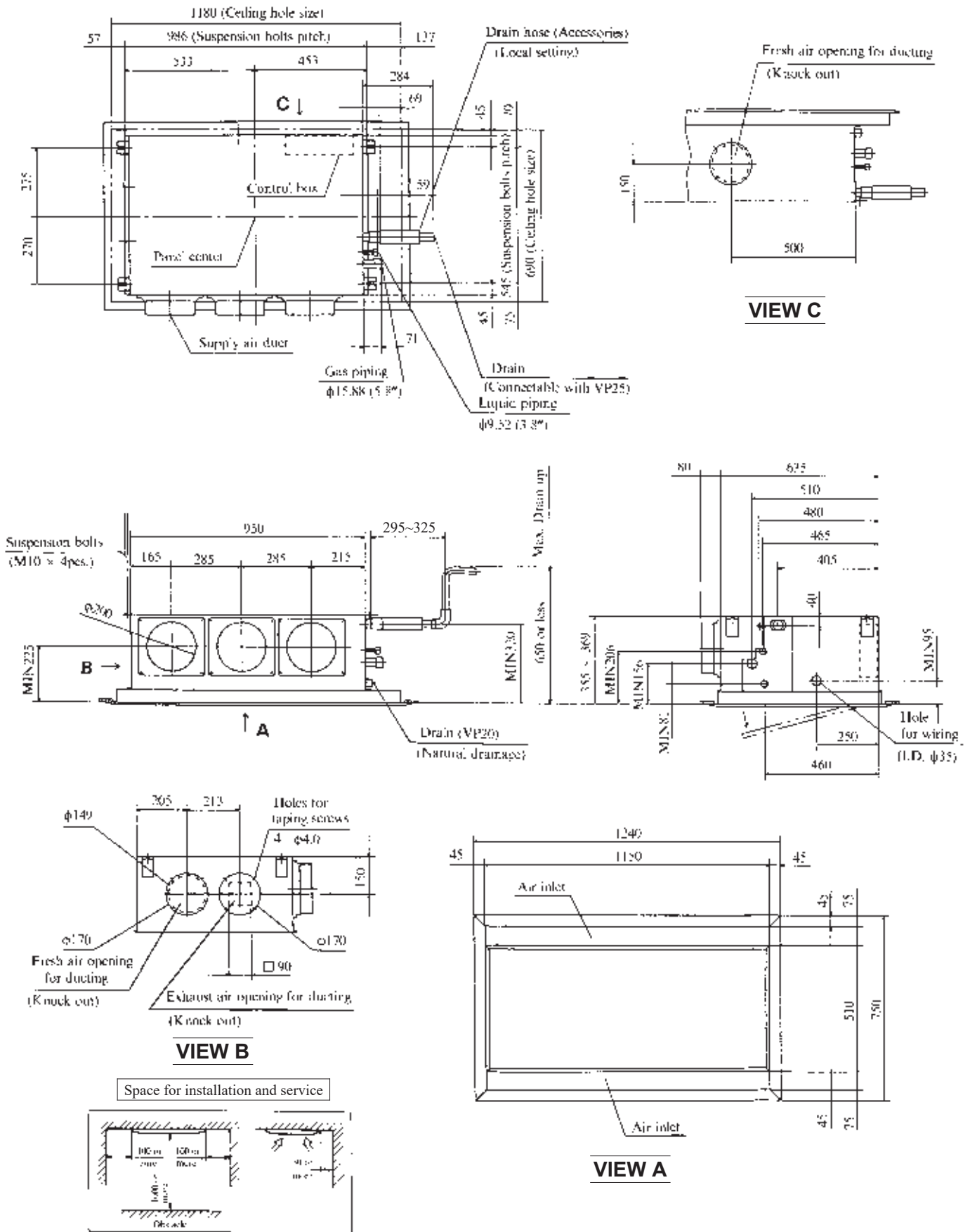

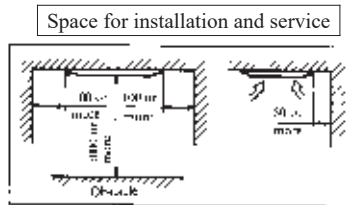
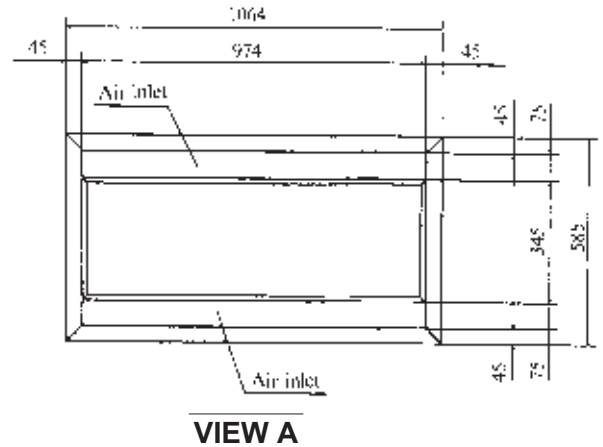
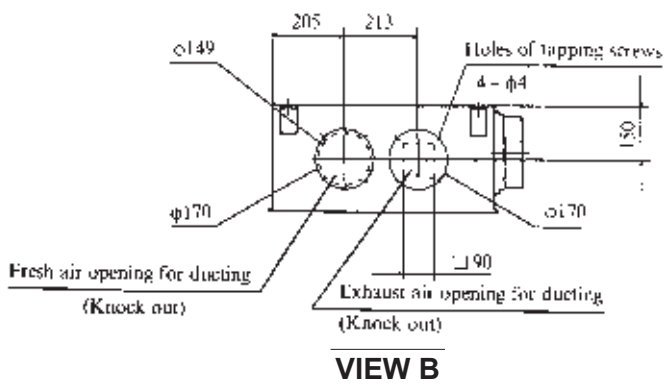
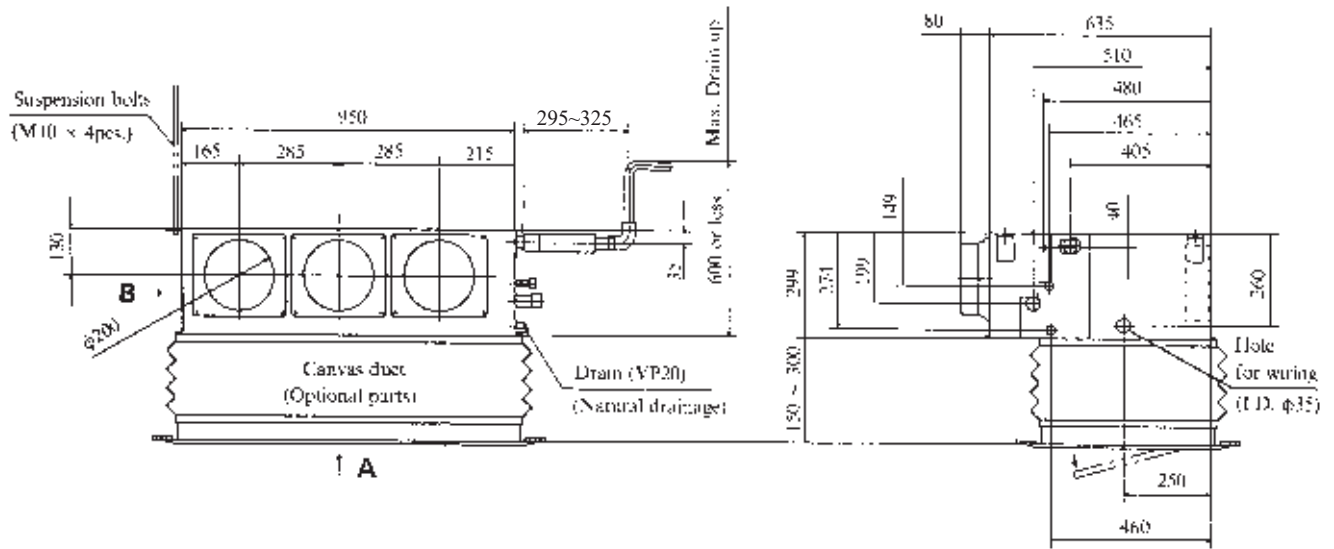
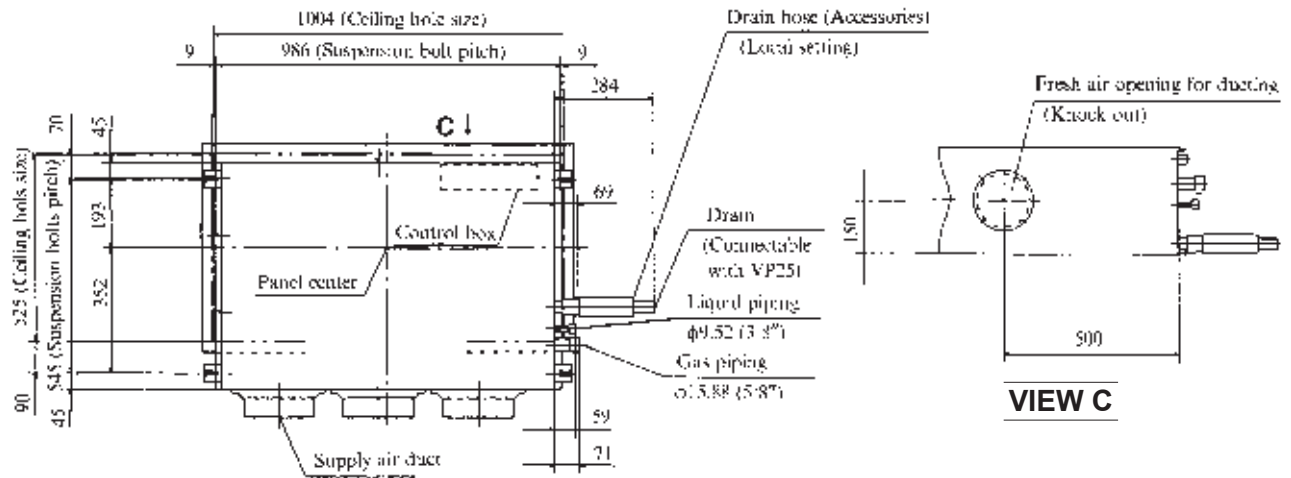

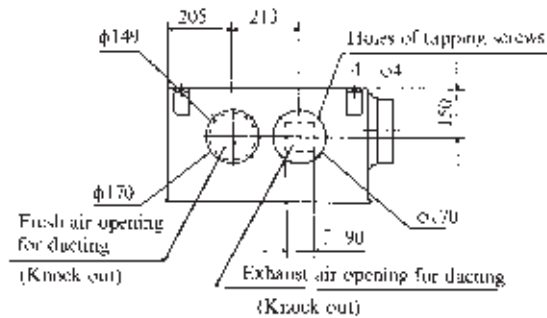
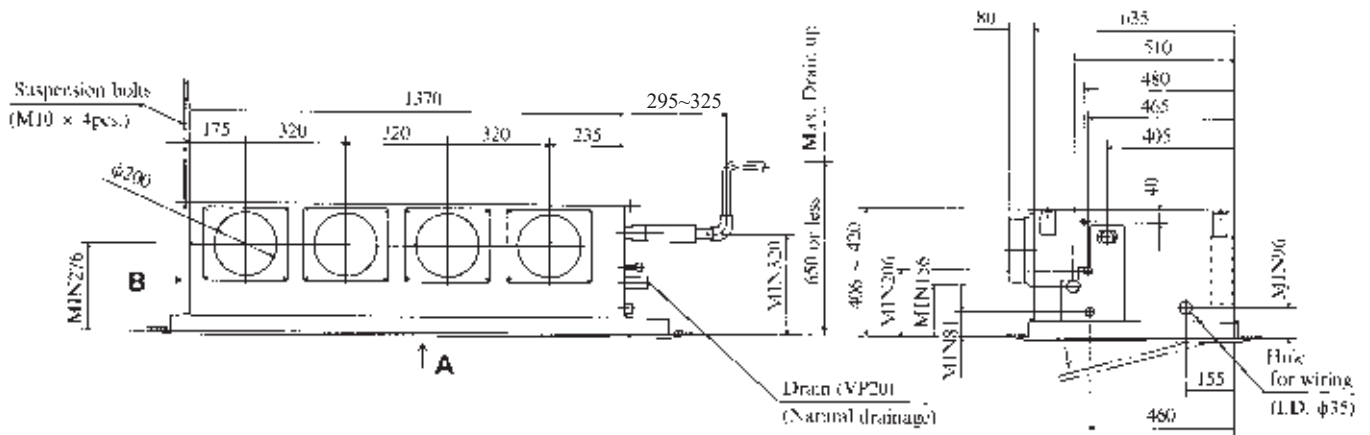
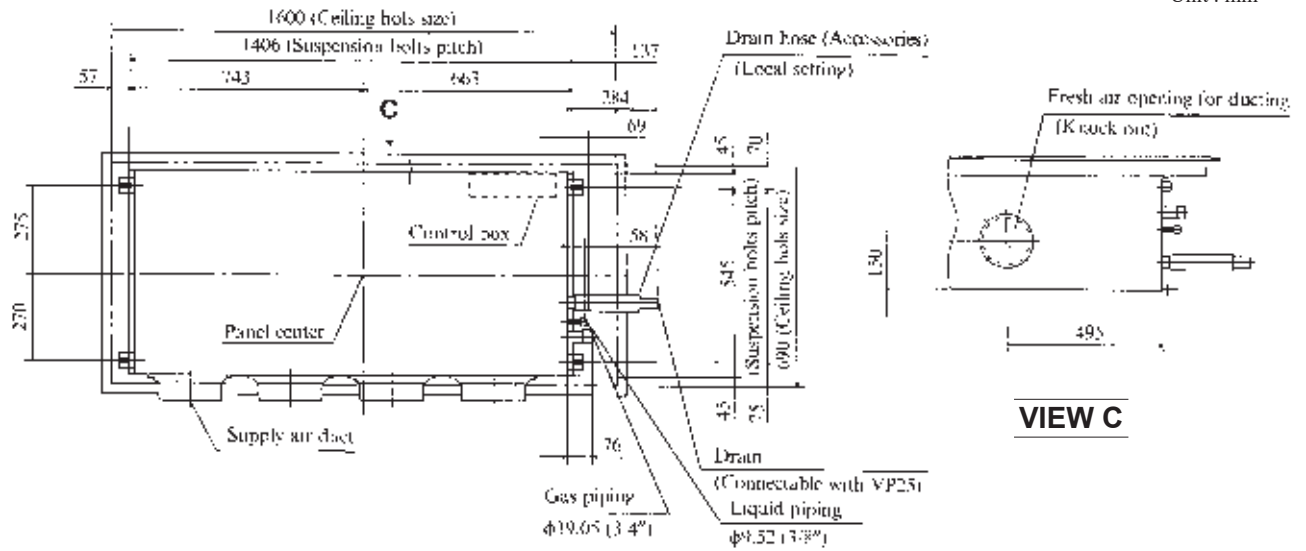

VIEW B

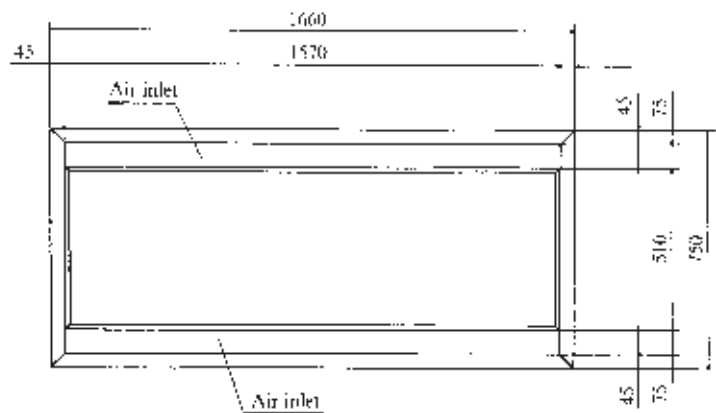
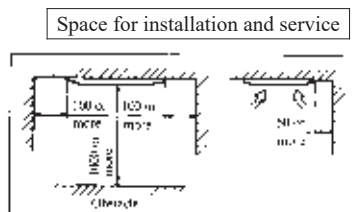

VIEW A

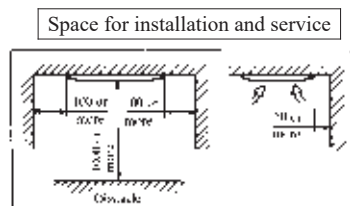
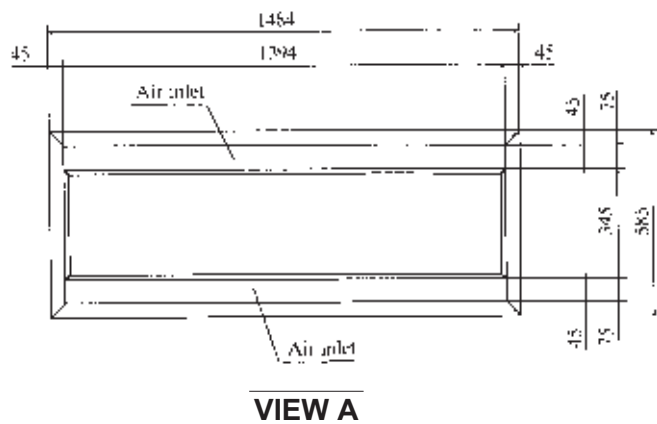
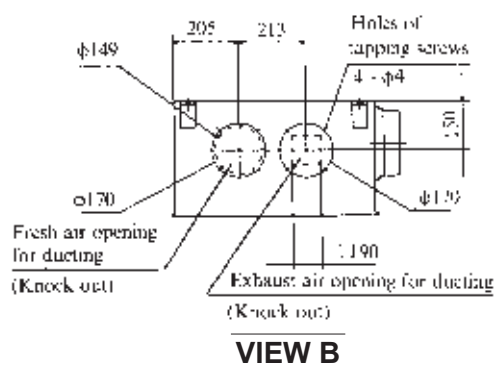
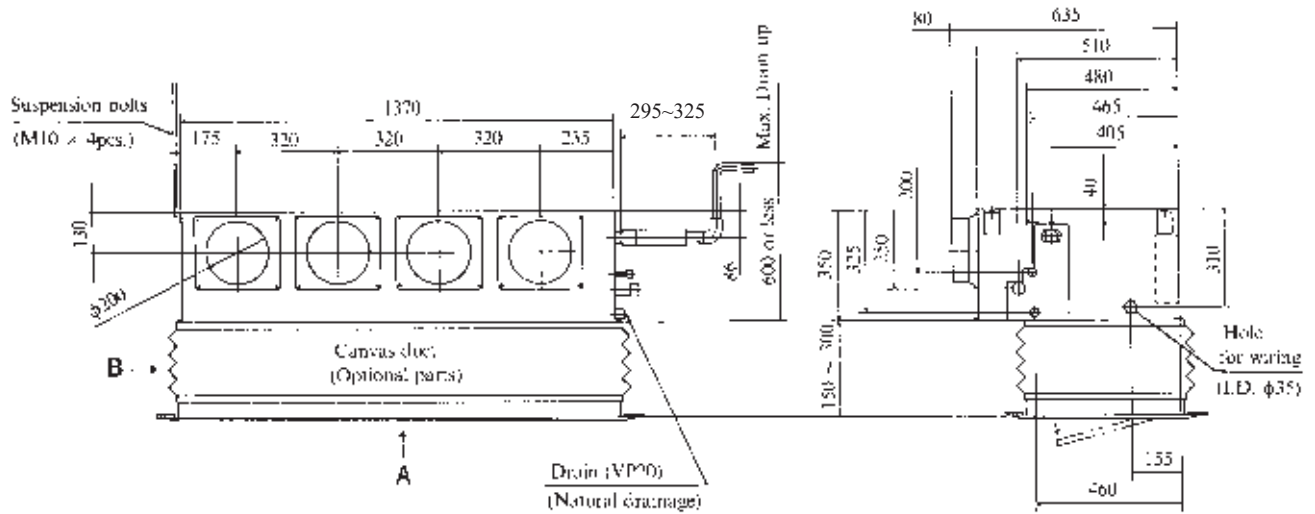
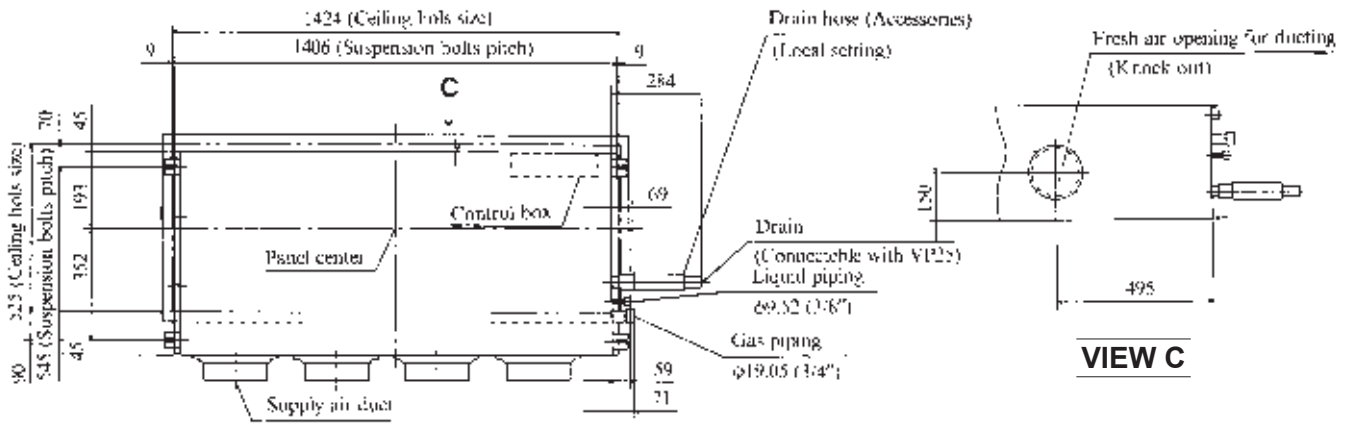

(e) Satellite ducted type (FDUM)

Models FDUM321HKXE2,401HKXE2,501HKXE2

Unit : mm

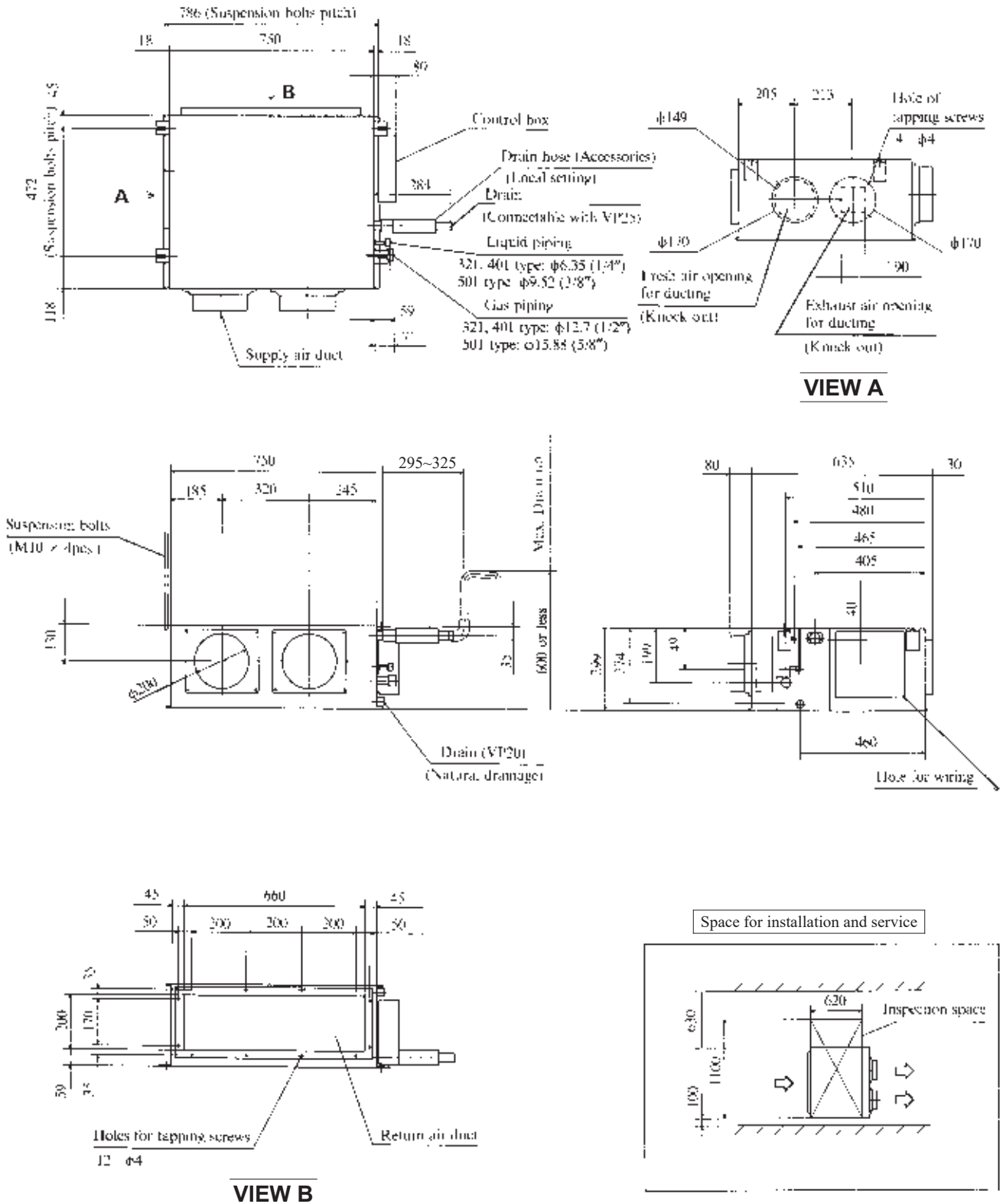

Models FDUM631HKXE2,801HKXE2

Unit : mm

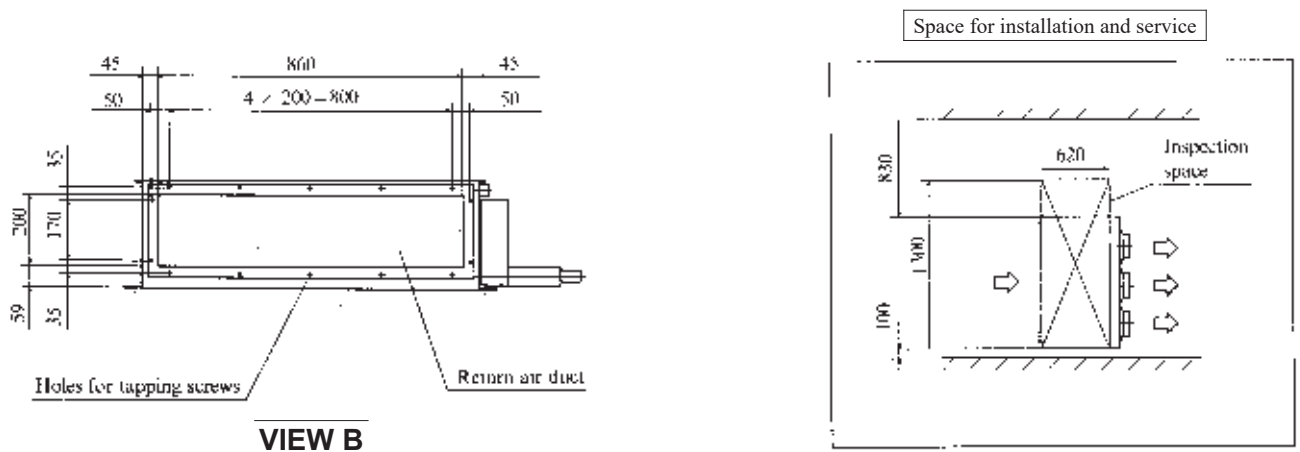
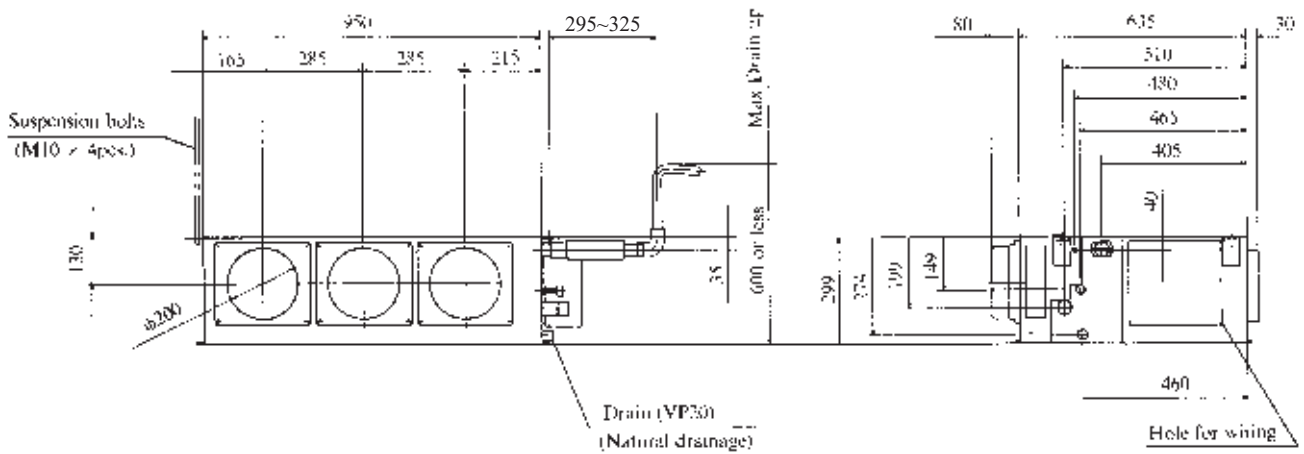
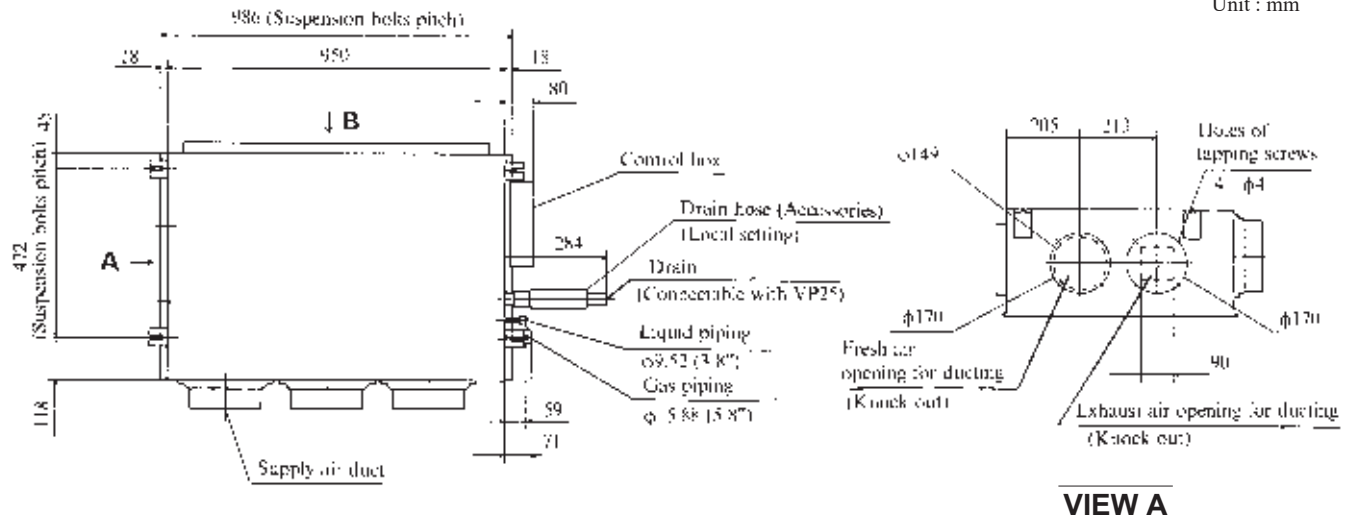

Models FDUM1001HKXE2,1251HKXE2

Unit : mm

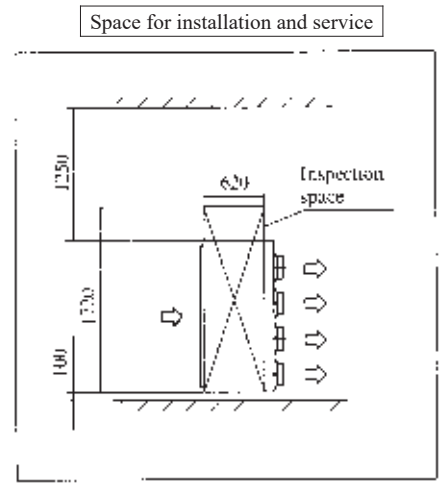
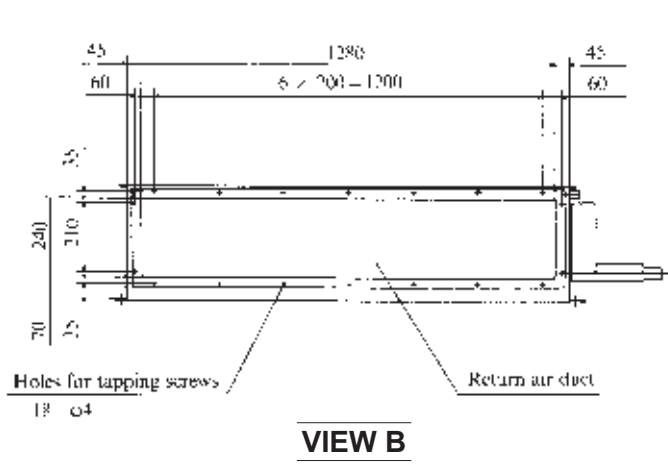
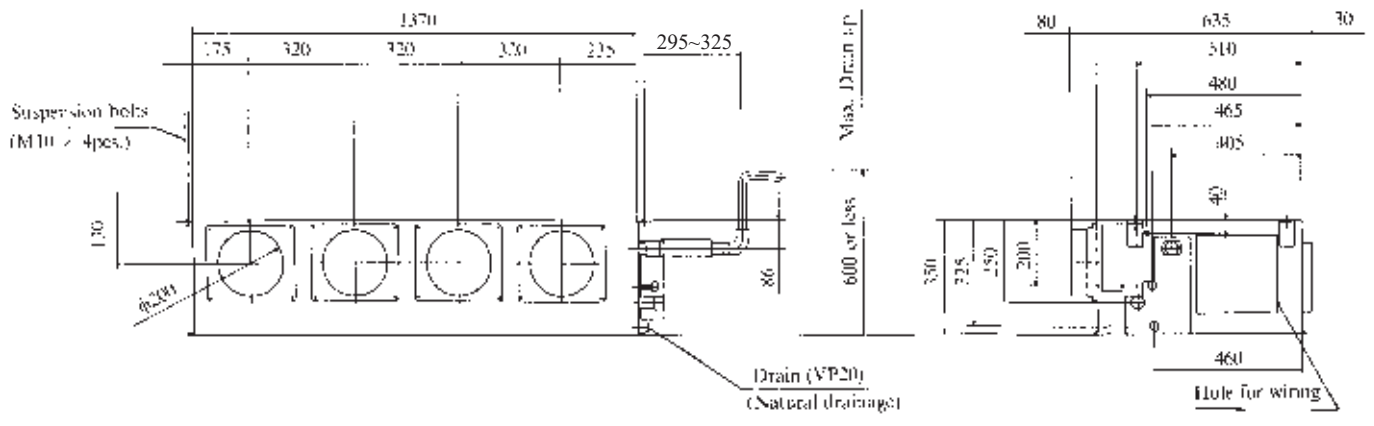
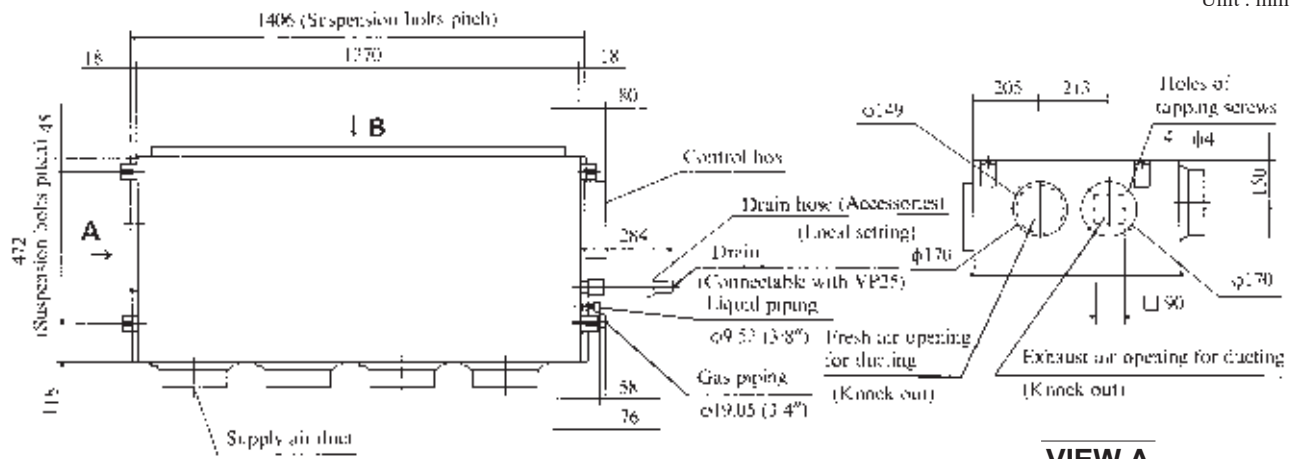

Model FDE1001HKXE2

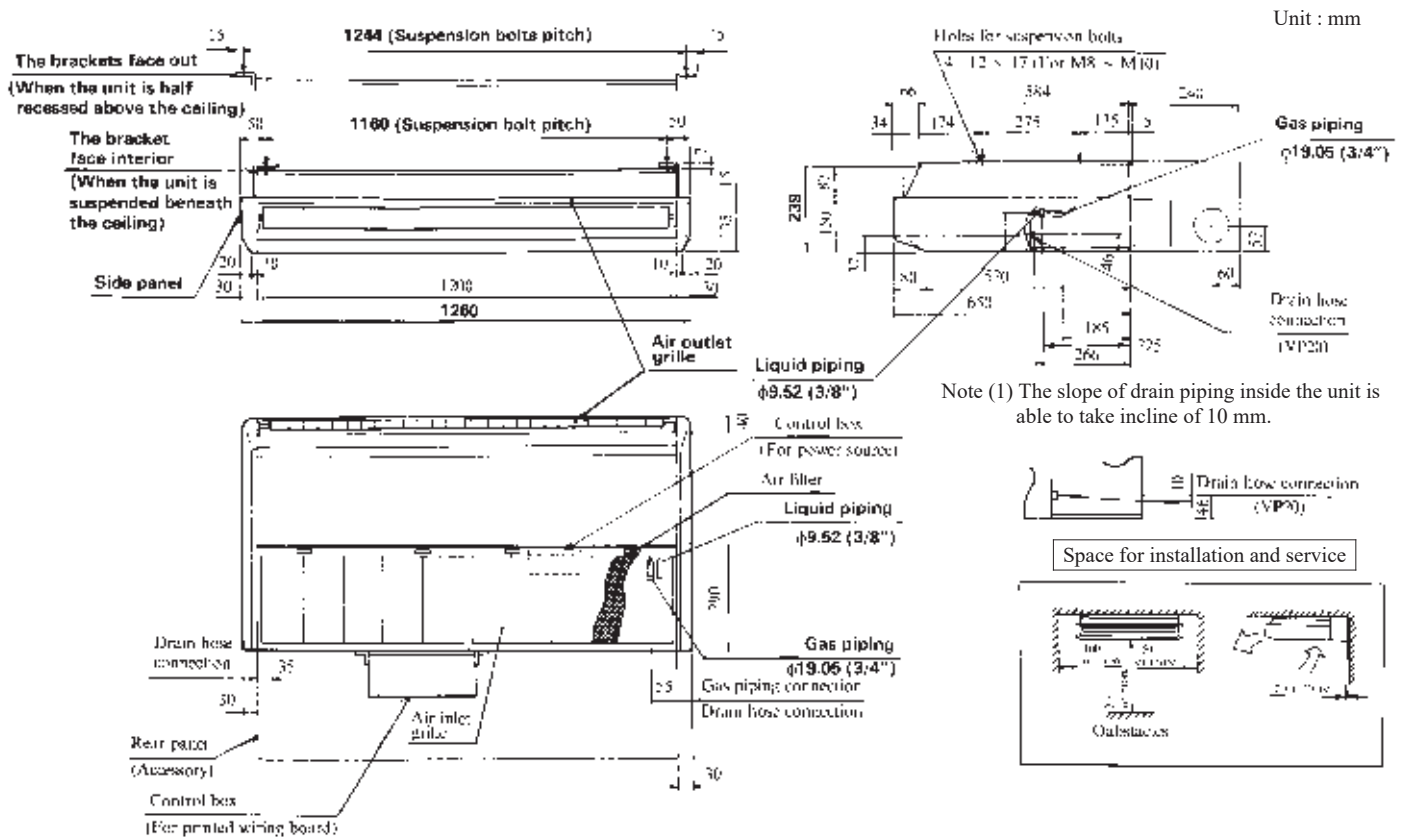

Model FDE1251HKXE2

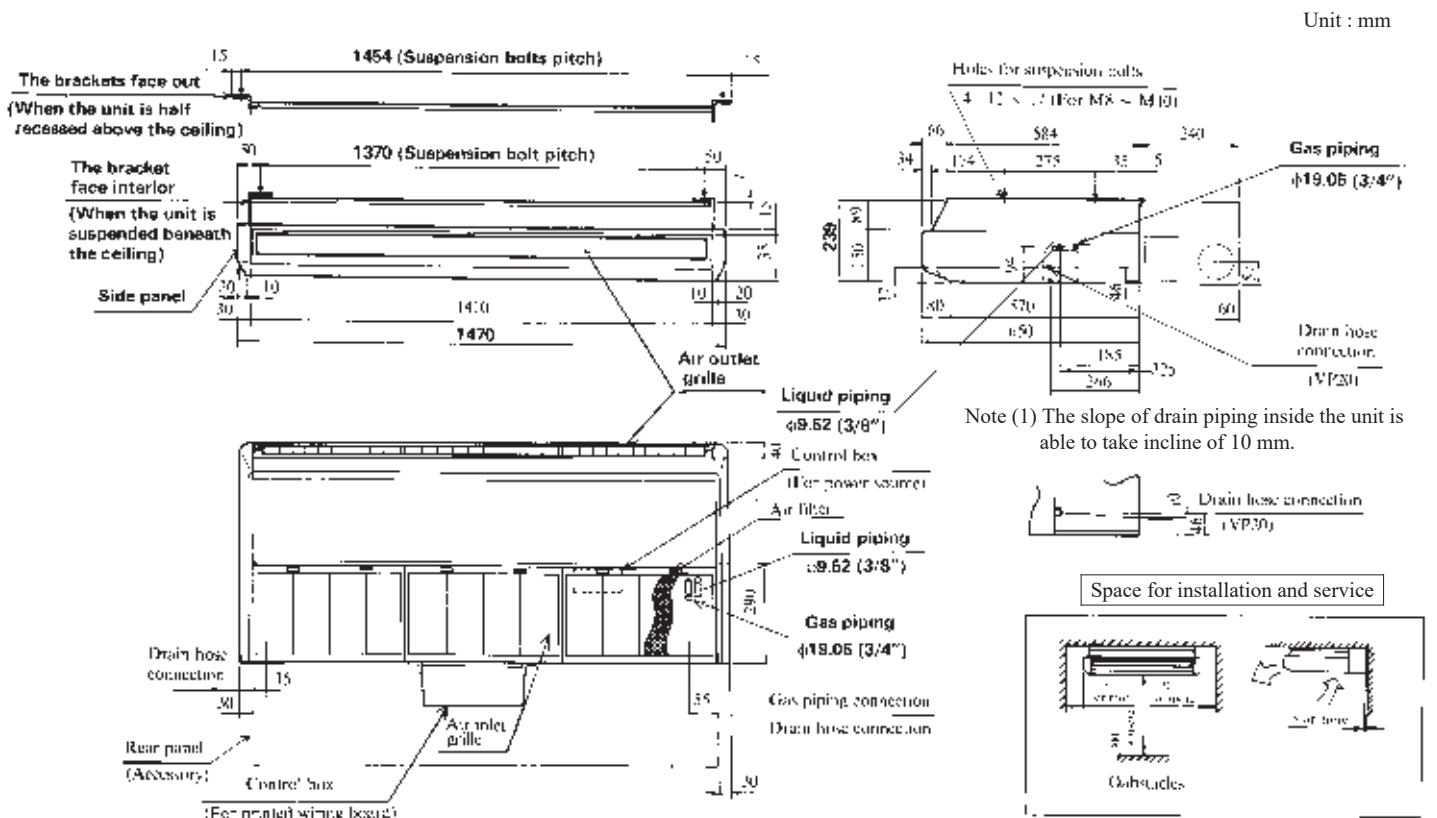

(g) Wall mounted type (FDKY)

Models FDKY251HKXE2,321HKXE2,401HKXE2

Unit : mm

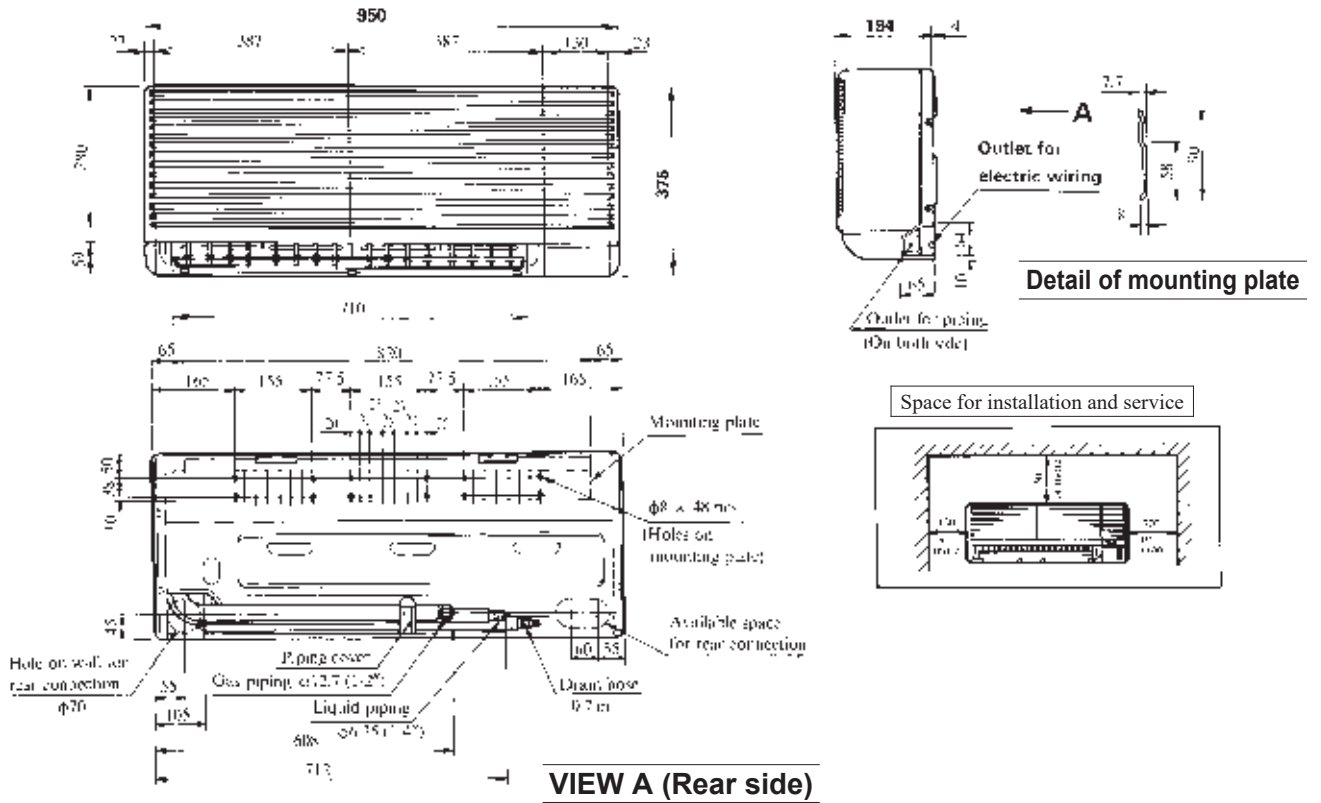

Model FDKY501HKXE2

Unit : mm

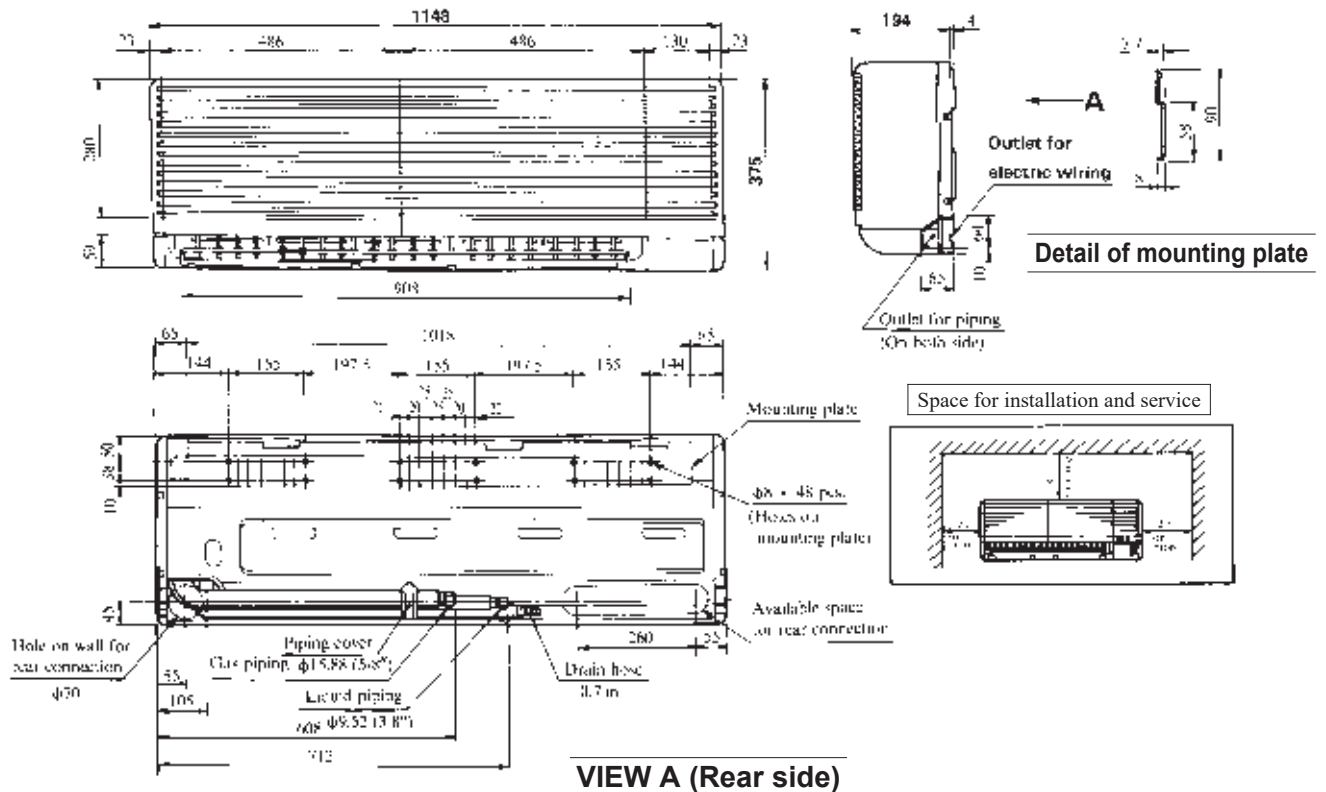

Model FDKY631HKXE2

Unit : mm

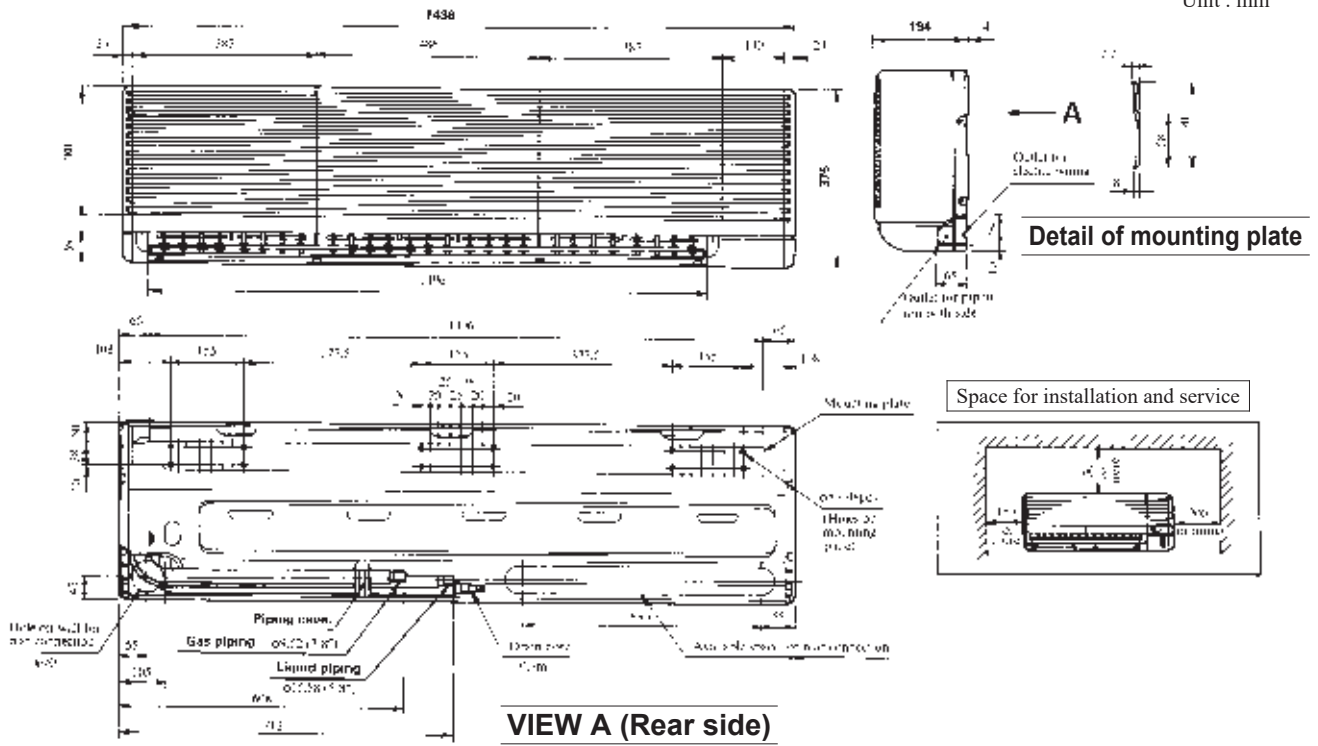

(h) Floor standing type (FDFL)

Models FDFL251HKXE2,401HKXE2,631HKXE2

Value in () indicates 631 type.

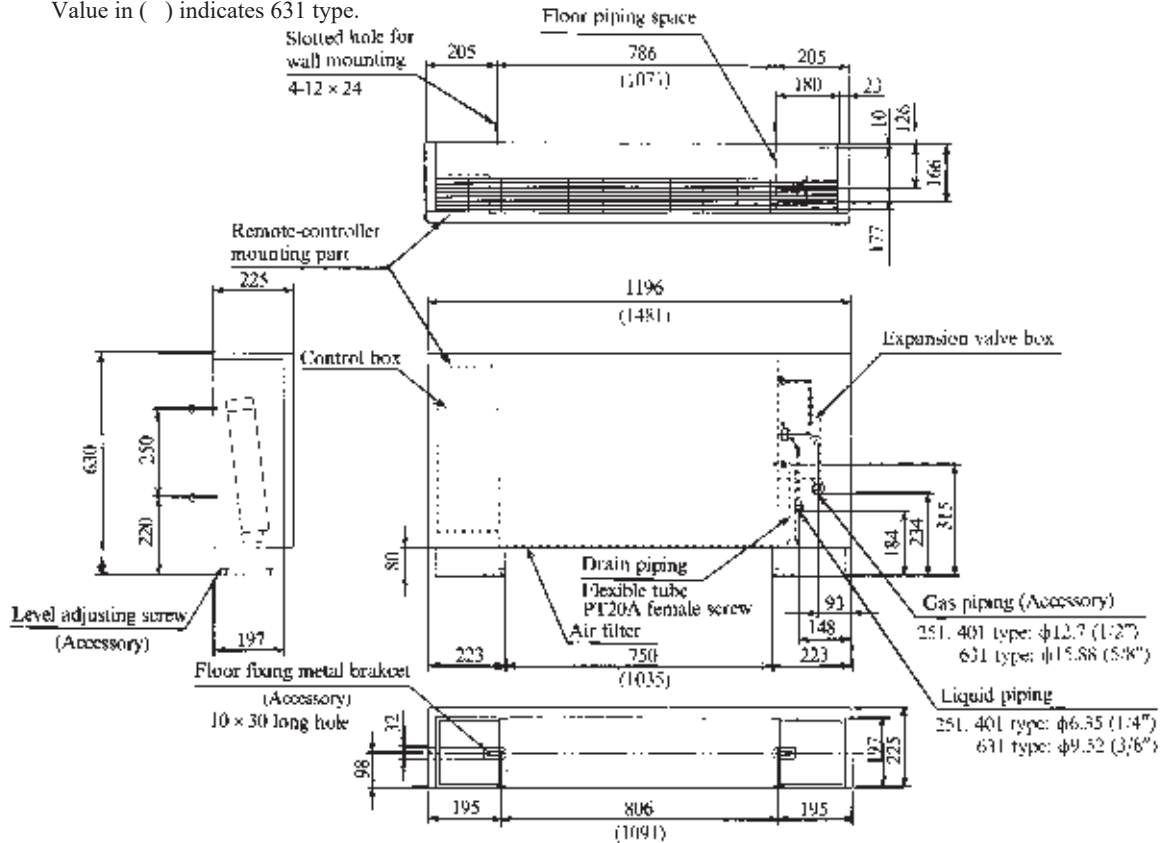

(2) Remote controller (Optional parts)

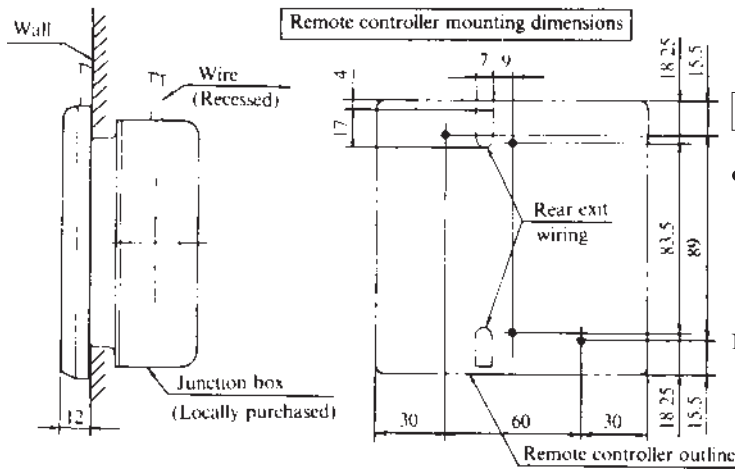
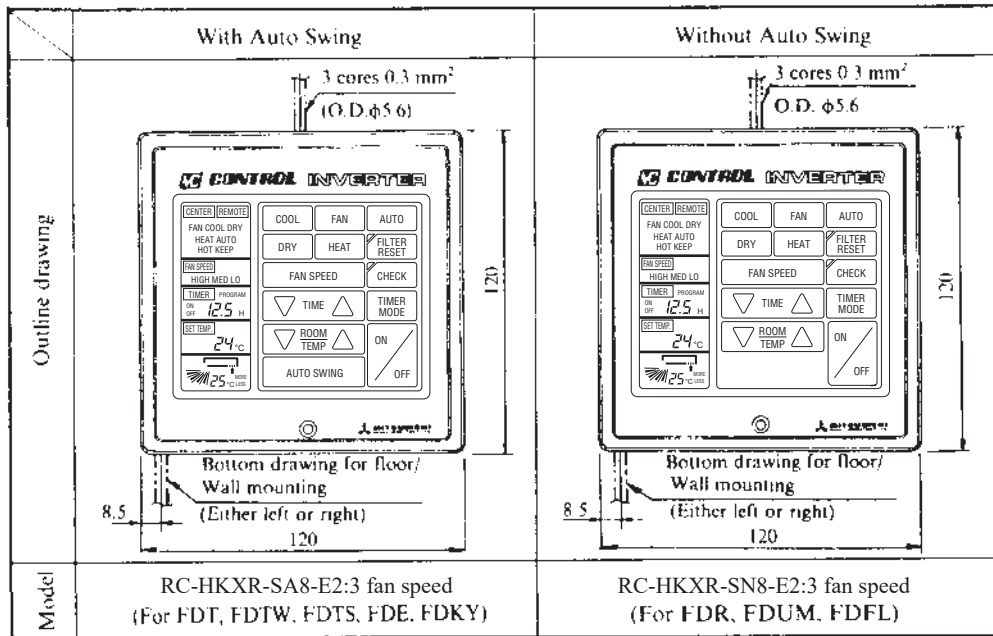

JIS box to be used

- JIS C8336 Outlet box-Middle size, square-deep type and JIS C8336 switch cover-for 2pcs. With paint margin.

Notes (1) Allowable length of remote controller cable: 600 m

Allowable rang of wire thickness and length

Standard	Within 0.3 mm ²	× Within 100 m
	0.5 mm ²	× Within 200 m
	0.75 mm ²	× Within 300 m
	1.25 mm ²	× Within 400 m
	2 mm ²	× Within 600 m

- Standard length of remote controller cable : 15m for All Models.

(3) Individual flow divide controller (Optional Part)

HPFD01R-E

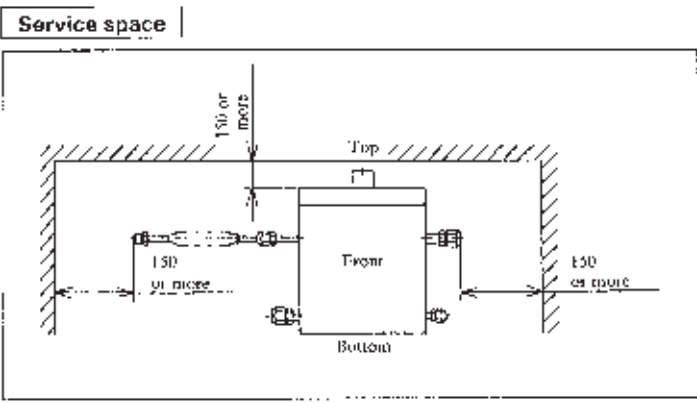
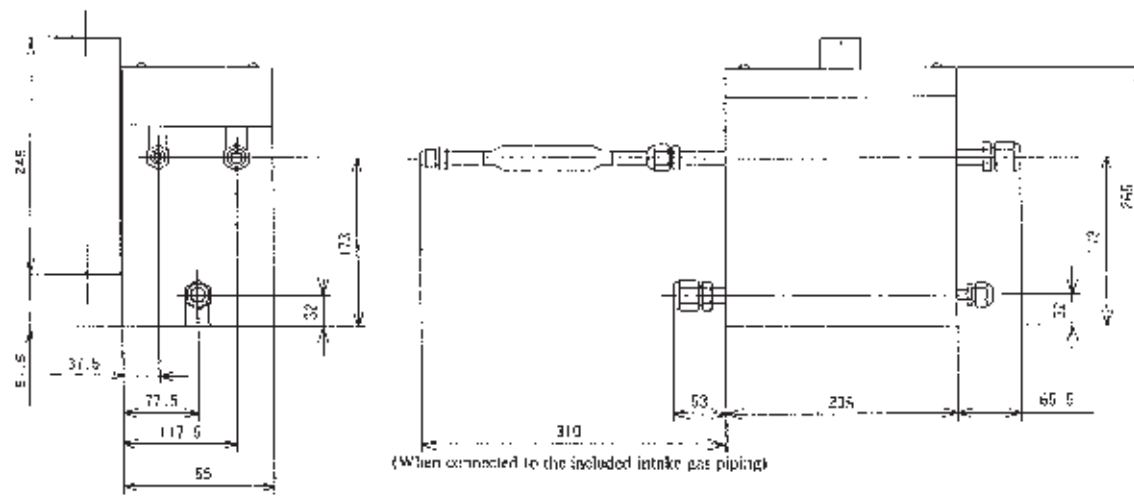
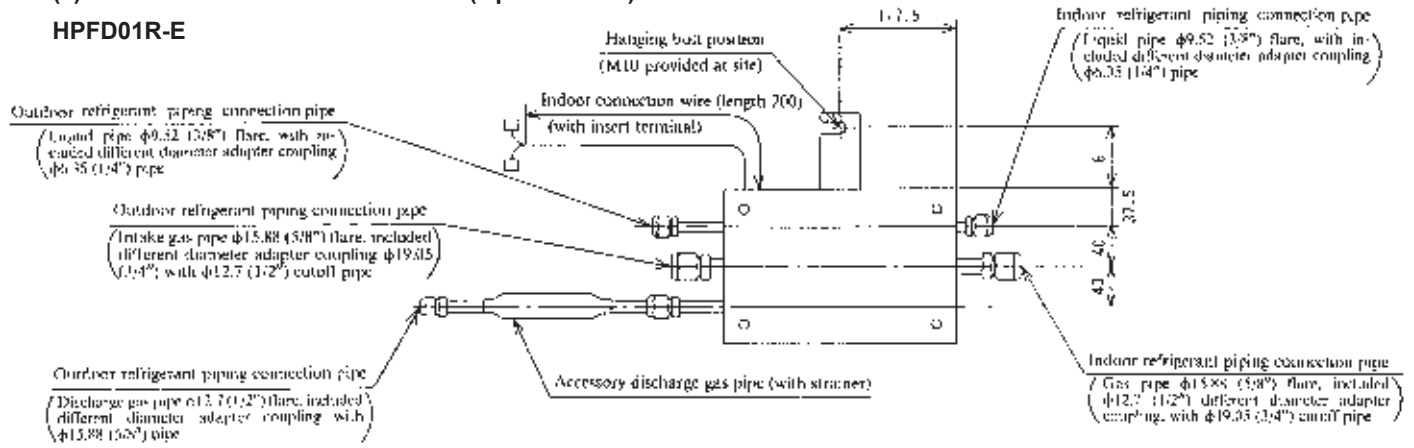

• Inspection door

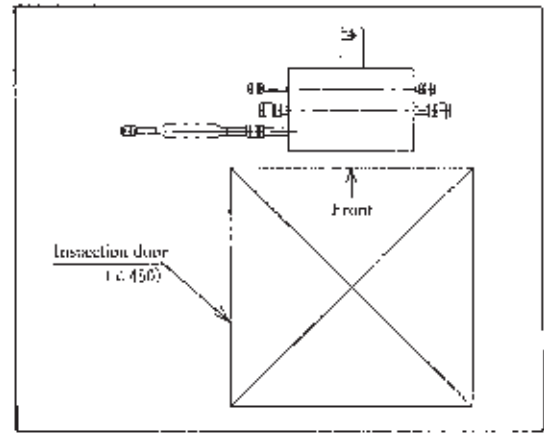

- Note (1) Do not operate the unit without the indoor unit connected to the individual flow divide controller.
- (2) Be sure to install the included strainer in the outdoor discharge gas connection pipe.
- (3) Do not install the flow divide controller upside down. Install so that the body is level.
- (4) Weight: 6 kg

(5) Use the indoor unit connection capacity to select a different diameter adapter coupling from the following table. (Use the flare nuts that are included with the flow divide controller.)

Different diameter adapter couplings				
For indoor gas piping	For indoor liquid piping	For outdoor intake gas piping	For outdoor discharge gas piping	For outdoor liquid piping
1 unit	1 unit	1 unit	1 unit	1 unit

(4) Outdoor unit
 FDC2001HKXRE2, 2501HKXRE2

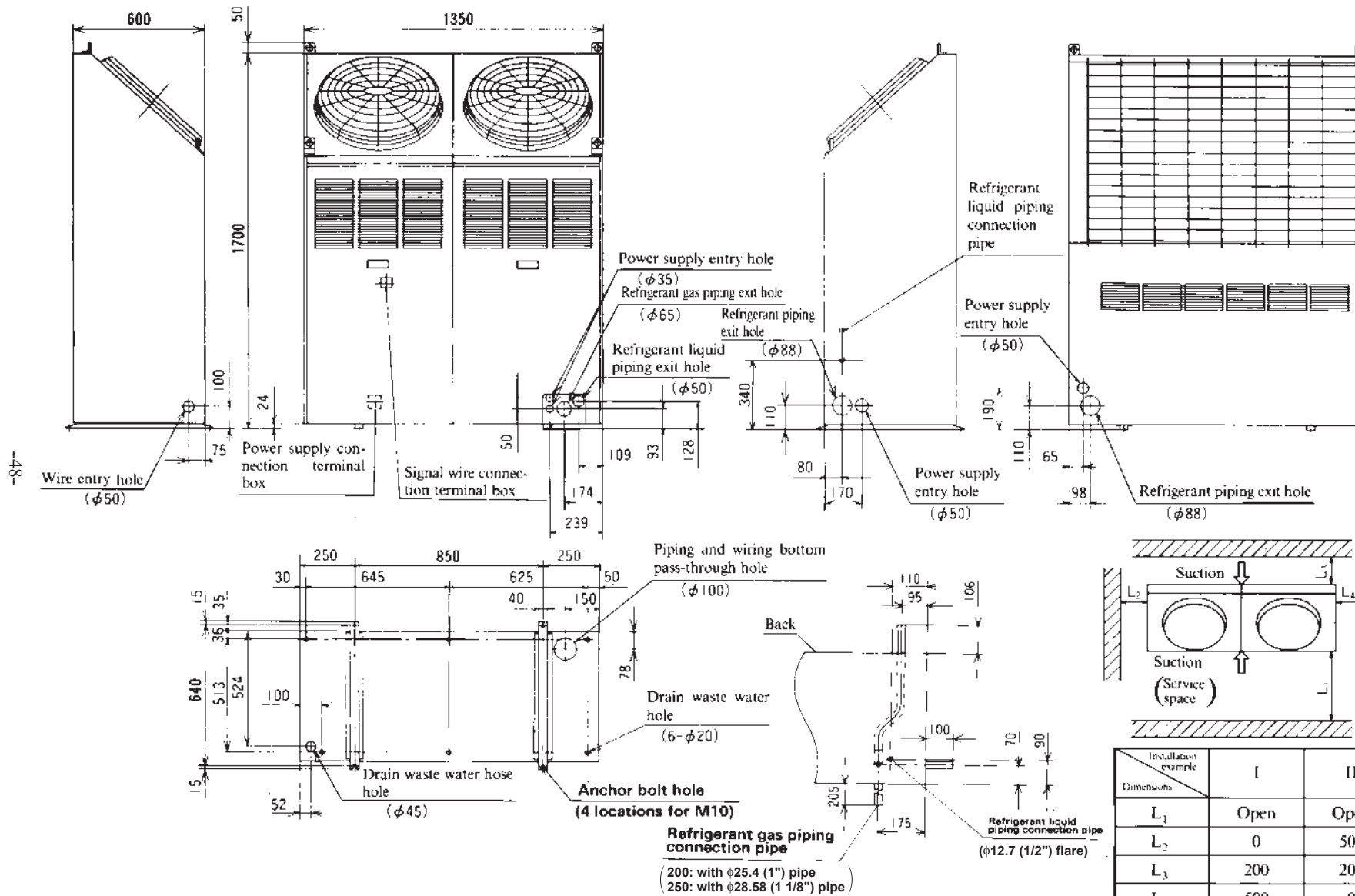

Dimensions after connecting included refrigerant piping
(Top view)

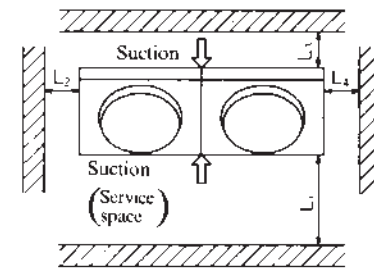

(Unit: mm)

Installation example	I	II	III
Dimensions			
L ₁	Open	Open	500
L ₂	0	500	500
L ₃	200	200	200
L ₄	500	0	500

- Note (1) Be sure to fasten down the unit with the anchor bolts.
 (2) If in a location with strong winds, position the air discharge outlet perpendicular to the wind direction.
 (3) Provide at least 1 m of space above the unit.

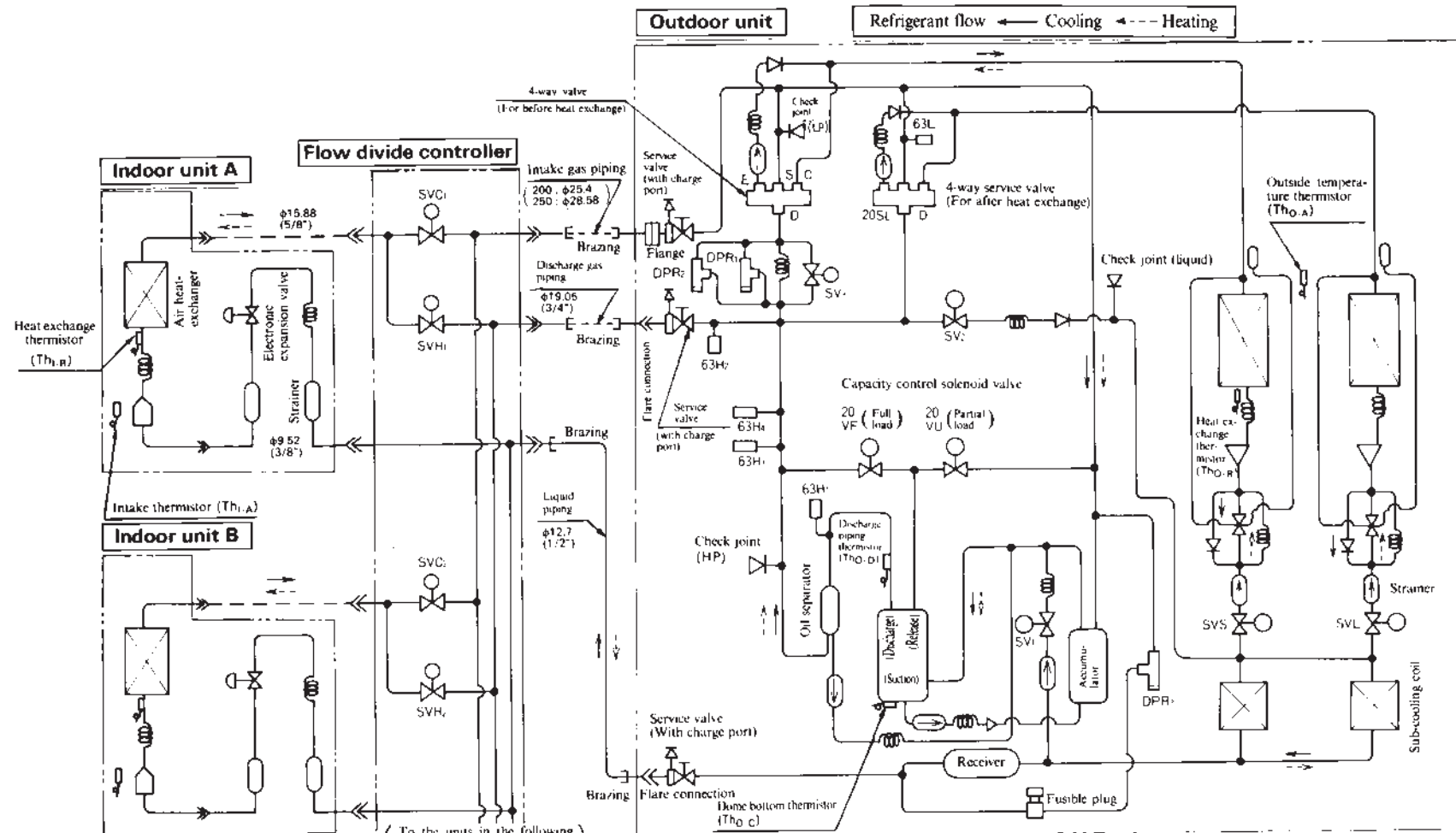

(1) Solenoid valve operation chart

	During compressor capacity control		During discharge temperature and dome bottom temperature control
	Full load	Partial load	
SV ₁			Open
20V _F	Open	Closed	
20V _L	Closed	Open	

Note (1) The solenoid valve is open during magnetic inductance and closed when there is not magnetic inductance.

(2) Preset point of protective devices

- 63H₁: 3.0 open, 2.4 closed MPaG (30 open, 24 closed kg/cm²G) [for protective]
- 63H₂: 2.55 open, 2.15 closed MPaG (25.5 open, 21.5 closed kg/cm²G) [for high-pressure control (Hz decrease)]
- 63H₃: 2.2 open, 1.9 closed MPaG (22 open, 19 closed kg/cm²G) [for high-pressure decrease control]
- 63H₄: 1.5 open, 1.75 closed MPaG (15 open, 17.5 closed kg/cm²G) [for high-pressure increase control]
- 63L: 0.2 open, 0.28 closed MPaG (2.0 open, 2.8 closed kg/cm²G) [for low-pressure increase control]
- DPR_{1,2}: 1.8 open MPaG (18 open kg/cm²G) DPR₃: 2.4 open MPaG (24 open kg/cm²G)

(3) Function of thermistor

- Th_{O-A}: For low outside air cooling/heating, frost removal control
- Th_{O-R}: For frost removal control
- Th_{O-D}: For Discharge piping temperature control
- Th_{O-C}: For dome bottom temperature control
- Th_{L-R}: For fan control during heating
For frost prevention during cooling

(4) Flow divide controller solenoid valve action chart

	Power supply OFF	Power supply ON	Cooling ⁽¹⁾	Heating ⁽¹⁾	Blower	Detrost
SVH	Closed	Closed	Closed	Open	Closed	Closed
SVC	Closed	Open	Open	Closed	Open	Open

Note (1) Including for pauses, stops, and errors.

(1) Indoor unit capacity (a) (b) (c)

Correction of outdoor unit capacity according to capacity of indoor unit to be operated simultaneously

FDC2001HKXE2,2501HKXE2

(2) Sensible heat capacity

FDT251HKXE2,321HKXE2,401HKXE2,501HKXE2

FDT631HKXE2,801HKXE2,1001HKXE2,1251HKXE2

FDTW251HKXE2,401HKXE2,501HKXE2,631HKXE2

FDTW801HKXE2,1001HKXE2,1251HKXE2

FDTs251HKXE2,321HKXE2,401HKXE2,631HKXE2

FDR201HKXE2,251HKXE2,401HKXE2,501HKXE2

FDR631HKXE2,801HKXE2,1001HKXE2,1251HKXE2

FDUM321HKXE2,401HKXE2,501HKXE2,631HKXE2

FDUM801HKXE2,1001HKXE2,1251HKXE2

FDE321HKXE2,401HKXE2,501HKXE2,631HKXE2

FDE1001HKXE2,1251HKXE2 **FDFL**251HKXE2,401HKXE2

FDFL631HKXE2 **FDKY**251HKXE2,321HKXE2,401HKXE2

FDKY501HKXE2,631HKXE2

1.5 Selection chart

(1) Indoor unit capacity

Correct the cooling and heating capacity in accordance with the conditions as follows. The net cooling and heating capacity can be obtained in the following way.

$$\text{Net capacity} = \text{Capacity shown on specifications} \times \text{Correction factors as follows.}$$

(a) Coefficient of cooling and heating capacity in relation to temperatures

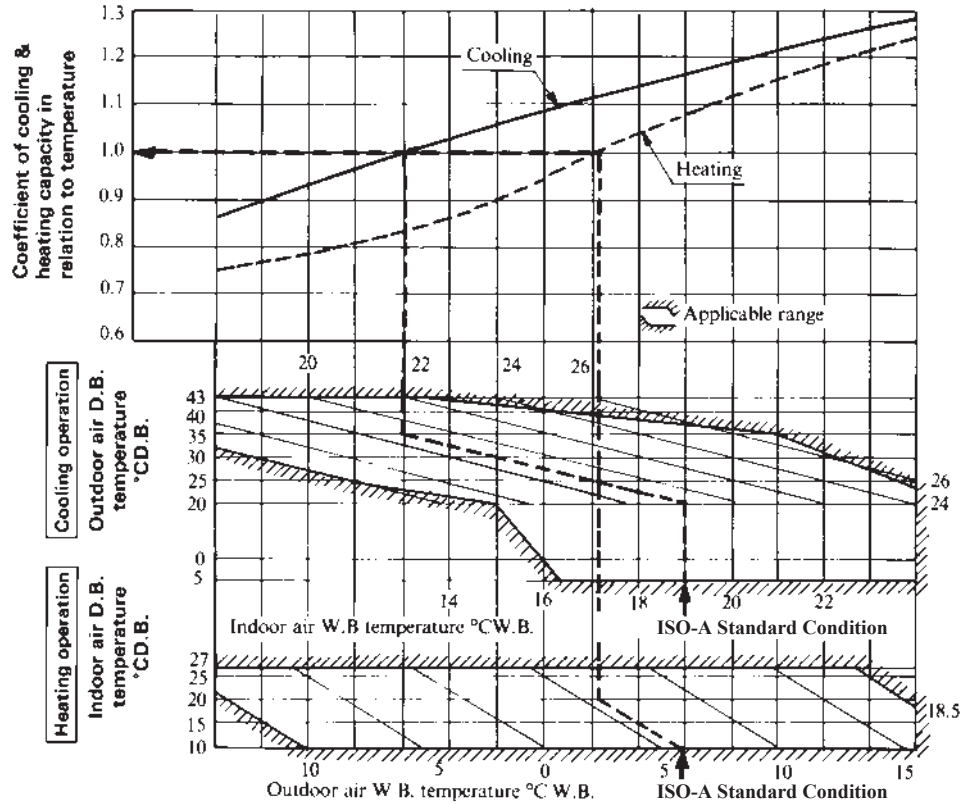

(b) Correction of cooling and heating capacity in relation to one way length of refrigerant piping.

Equivalent piping length [m] ⁽¹⁾	5	10	15	20	25	30	35	40	45	50
Cooling	1.0	0.99	0.975	0.965	0.95	0.94	0.925	0.915	0.9	0.89
Heating	1.0	1.0	1.0	1.0	1.0	0.995	0.995	0.99	0.99	0.985
Equivalent piping length [m]	55	60	65	70	75	80	85	90	95	100
Cooling	0.875	0.865	0.85	0.84	0.825	0.815	0.8	0.79	0.775	0.765
Heating	0.985	0.98	0.98	0.975	0.975	0.97	0.97	0.965	0.965	0.96
Equivalent piping length [m]	105	110	115	120	125					
Cooling	0.745	0.74	0.725	0.715	0.7					
Heating	0.96	0.955	0.955	0.95	0.95					

Note (1) Equivalent piping length can be obtained by calculating as follows.

Equivalent piping length = Real gas piping length + Number of bends in gas piping × Equivalent piping length of bends.

Equivalent length of each joint

Unit : m/one part

Gas piping size	φ12.7	φ15.88	φ19.05	φ25.4	φ28.58
Joint (90° elbow)	0.10	0.10	0.15	0.15	0.20

(c) When the outdoor unit is located at a lower height than the indoor unit in cooling operation and when the outdoor unit is located at a higher height than the indoor unit in heating operation, the following values should be subtracted from the values in the above table.

Height difference between the indoor unit and outdoor unit in the vertical height difference	5 m	10 m	15 m	20 m	25 m	30 m
Adjustment coefficient	0.01	0.02	0.03	0.04	0.05	0.06

Height difference between the indoor unit and outdoor unit in the vertical height difference	35 m	40 m	45 m	50 m
Adjustment coefficient	0.07	0.08	0.09	0.10

Table of bypass factor

Model		FDT model						FDTW model				
		251, 321 type	401, 501 type	631 type	801 type	1001 type	1251 type	251, 401, 501 type	631 type	801 type	1001 type	1251 type
Air flow	Hi	0.061	0.061	0.069	0.074	0.076	0.025	0.094	0.064	0.081	0.075	0.063
	Me	0.045	0.041	0.049	0.047	0.060	0.019	0.069	0.040	0.064	0.060	0.050
	Lo	0.030	0.030	0.037	0.031	0.050	0.013	0.044	0.034	0.040	0.045	0.038

Model		FDTS model			FDR model				
		251, 321 type	401 type	631 type	201, 251 type	401, 501 type	631, 801, 1001 type	1001 type	1251 type
Air flow	Hi	0.023	0.031	0.030	0.026	0.035	0.039	0.085	0.035
	Me	0.020	0.023	0.021	0.023	0.026	0.032	0.073	0.030
	Lo	0.016	0.016	0.013	0.021	0.021	0.023	0.060	0.023

Model		FDUM model					FDE model		
		321 type	405, 501 type	631, 801 type	1001 type	1251 type	321, 401, type	631 type	1001, 1251 type
Air flow	Hi	0.032	0.035	0.039	0.085	0.035	0.031	0.030	0.018
	Me	0.026	0.026	0.032	0.073	0.030	0.023	0.021	0.014
	Lo	0.019	0.021	0.023	0.060	0.023	0.016	0.013	0.010

Model		FDKY model			FDFL model		
		251, 321 type	401 type	631 type	251 type	401 type	631 type
Air flow	Hi	0.051	0.063	0.079	0.031	0.041	0.032
	Me	0.043	0.051	0.066	0.026	0.031	0.023
	Lo	0.035	0.035	0.053	0.022	0.022	0.014

Correction of outdoor unit capacity according to capacity of indoor unit to be operated simultaneously

FDC2001HKXRE2

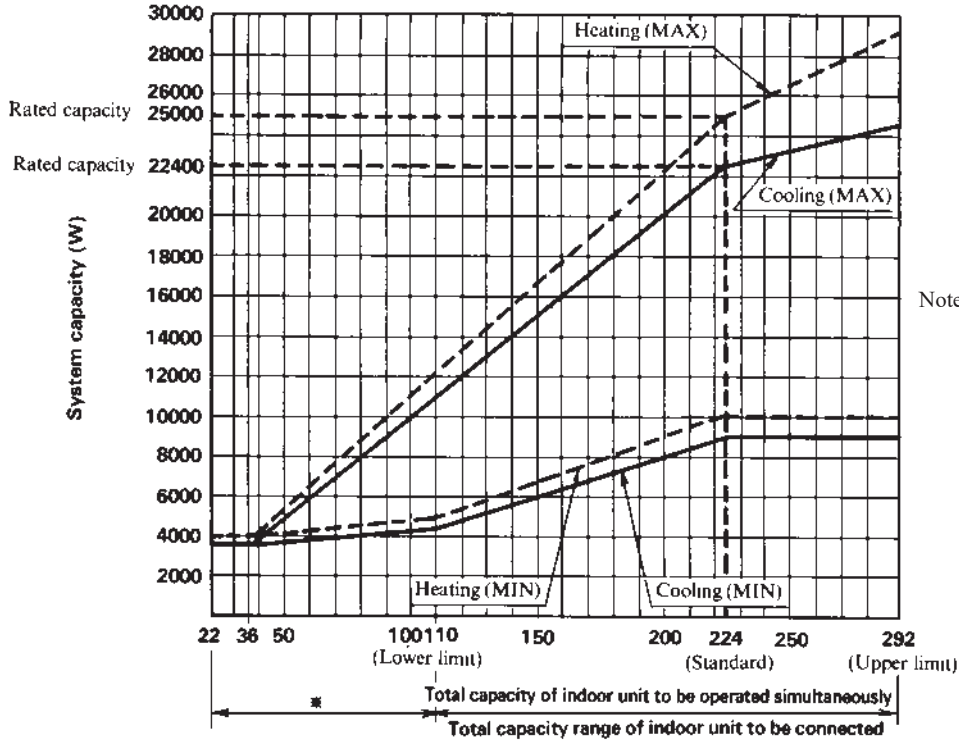

Notes (1) MAX: Frequency 95Hz
 MIN: Frequency 35Hz
 (2) The range marked with ※ is for indoor unit only or indicates that small number of units are operated.

FDC2501HKXRE2

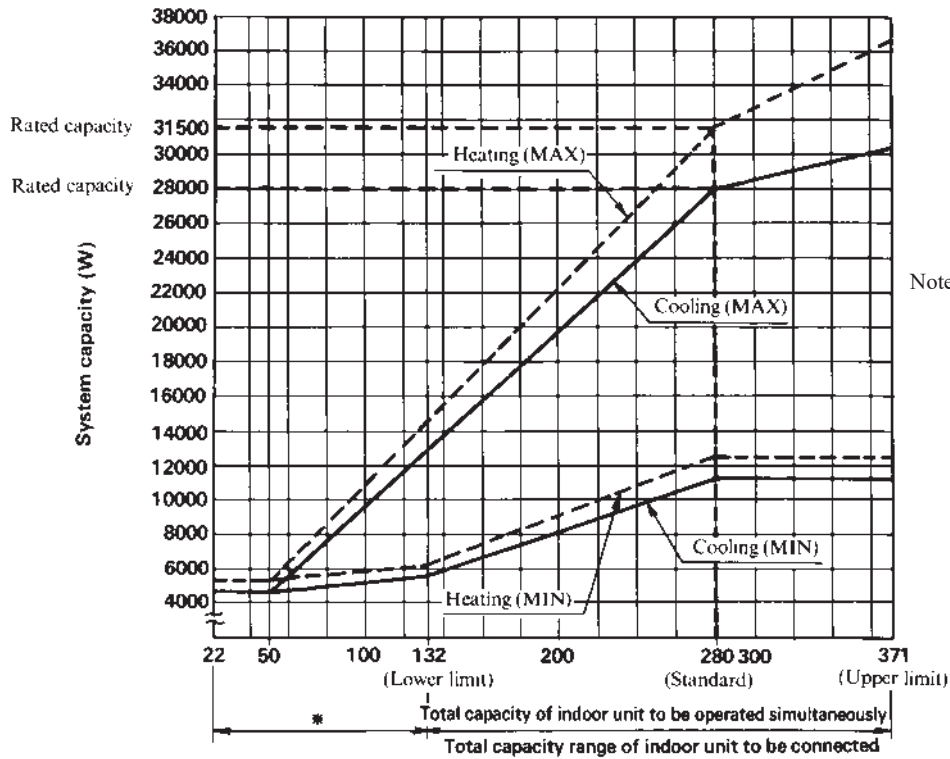

Notes (1) MAX: Frequency 95Hz
 MIN: Frequency 35Hz
 (2) The range marked with ※ is for indoor unit only or indicates that small number of units are operated.

(2) Sensible heat capacity

(a) FDT Series

Model FDT251HKXE2

Air flow (m ³ /min)	Outdoor air temp. (°CDB)	Indoor air temperature											
		17.0°CWB		18.0°CWB		19.0°CWB		20.0°CWB		21.0°CWB		22.0°CWB	
		TC	SHC	TC	SHC	TC	SHC	TC	SHC	TC	SHC	TC	SHC
12	27	2.90	2.58	2.98	2.60	3.06	2.62	3.12	2.63	3.21	2.64	3.29	2.66
	29	2.83	2.55	2.92	2.57	3.00	2.59	3.07	2.61	3.14	2.62	3.23	2.64
	31	2.77	2.52	2.85	2.55	2.93	2.57	3.02	2.59	3.09	2.60	3.16	2.61
	33	2.69	2.49	2.78	2.52	2.87	2.54	2.95	2.56	3.04	2.58	3.10	2.59
	35	2.60	2.46	2.72	2.49	2.80	2.52	2.88	2.54	2.97	2.56	3.05	2.58
	37	2.54	2.43	2.63	2.46	2.73	2.49	2.82	2.52	2.90	2.54	2.98	2.55
	39	2.45	2.40	2.55	2.43	2.65	2.46	2.75	2.49	2.83	2.51	2.92	2.53

Model FDT321HKXE2

Air flow (m ³ /min)	Outdoor air temp. (°CDB)	Indoor air temperature											
		17.0°CWB		18.0°CWB		19.0°CWB		20.0°CWB		21.0°CWB		22.0°CWB	
		TC	SHC	TC	SHC	TC	SHC	TC	SHC	TC	SHC	TC	SHC
12	27	3.73	3.20	3.84	3.22	3.94	3.24	4.02	3.25	4.13	3.27	4.23	3.28
	29	3.64	3.16	3.75	3.19	3.86	3.21	3.95	3.23	4.04	3.24	4.15	3.26
	31	3.56	3.13	3.66	3.15	3.77	3.18	3.88	3.20	3.97	3.21	4.06	3.23
	33	3.46	3.09	3.58	3.12	3.69	3.15	3.79	3.17	3.90	3.19	3.98	3.20
	35	3.35	3.04	3.49	3.08	3.60	3.11	3.71	3.14	3.82	3.16	3.92	3.18
	37	3.26	3.01	3.38	3.04	3.51	3.08	3.62	3.11	3.73	3.13	3.84	3.15
	39	3.15	2.96	3.28	3.00	3.41	3.04	3.54	3.07	3.64	3.10	3.75	3.12

Model FDT401HKXE2

Air flow (m ³ /min)	Outdoor air temp. (°CDB)	Indoor air temperature											
		17.0°CWB		18.0°CWB		19.0°CWB		20.0°CWB		21.0°CWB		22.0°CWB	
		TC	SHC	TC	SHC	TC	SHC	TC	SHC	TC	SHC	TC	SHC
15	27	4.66	4.00	4.80	4.03	4.92	4.05	5.02	4.06	5.16	4.09	5.28	4.10
	29	4.55	3.95	4.69	3.99	4.82	4.01	4.94	4.03	5.05	4.05	5.18	4.07
	31	4.45	3.91	4.58	3.94	4.72	3.97	4.85	4.00	4.96	4.02	5.08	4.03
	33	4.33	3.86	4.47	3.90	4.61	3.93	4.74	3.96	4.88	3.99	4.98	4.00
	35	4.19	3.80	4.37	3.86	4.50	3.89	4.64	3.92	4.77	3.95	4.91	3.98
	37	4.08	3.76	4.22	3.80	4.39	3.85	4.53	3.88	4.66	3.91	4.80	3.94
	39	3.94	3.70	4.10	3.75	4.26	3.80	4.42	3.84	4.55	3.87	4.69	3.90

Model FDT501HKXE2

Air flow (m ³ /min)	Outdoor air temp. (°CDB)	Indoor air temperature											
		17.0°CWB		18.0°CWB		19.0°CWB		20.0°CWB		21.0°CWB		22.0°CWB	
		TC	SHC	TC	SHC	TC	SHC	TC	SHC	TC	SHC	TC	SHC
15	27	5.80	4.49	5.97	4.52	6.13	4.53	6.25	4.54	6.42	4.55	6.57	4.56
	29	5.67	4.43	5.84	4.46	6.00	4.48	6.15	4.50	6.28	4.50	6.45	4.52
	31	5.53	4.37	5.70	4.40	5.87	4.43	6.04	4.45	6.17	4.46	6.32	4.47
	33	5.39	4.31	5.57	4.34	5.73	4.37	5.90	4.40	6.07	4.42	6.19	4.42
	35	5.21	4.23	5.43	4.29	5.60	4.32	5.77	4.35	5.94	4.37	6.10	4.39
	37	5.07	4.17	5.25	4.21	5.47	4.27	5.63	4.30	5.80	4.32	5.97	4.34
	39	4.91	4.10	5.11	4.15	5.30	4.20	5.50	4.24	5.67	4.27	5.84	4.30

Note (1) Symbols are as follows :

TC : Total cooling capacity (kW)

SHC : Sensible heat capacity (kW)

Model FDT631HKXE2

Air flow (m ³ /min)	Outdoor air temp. (°CDB)	Indoor air temperature											
		17.0°CWB		18.0°CWB		19.0°CWB		20.0°CWB		21.0°CWB		22.0°CWB	
		TC	SHC	TC	SHC	TC	SHC	TC	SHC	TC	SHC	TC	SHC
16	27	7.36	5.32	7.57	5.35	7.77	5.36	7.92	5.35	8.14	5.36	8.34	5.36
	29	7.19	5.24	7.40	5.27	7.61	5.29	7.80	5.30	7.97	5.29	8.18	5.30
	31	7.01	5.16	7.23	5.19	7.44	5.22	7.65	5.24	7.82	5.24	8.01	5.24
	33	6.83	5.08	7.06	5.12	7.27	5.15	7.48	5.17	7.70	5.19	7.85	5.18
	35	6.60	4.97	6.89	5.04	7.10	5.07	7.31	5.10	7.53	5.12	7.74	5.14
	37	6.43	4.90	6.66	4.94	6.93	5.00	7.14	5.03	7.36	5.05	7.57	5.07
	39	6.22	4.80	6.48	4.86	6.72	4.91	6.97	4.96	7.19	4.99	7.40	5.01

Model FDT801HKXE2

Air flow (m ³ /min)	Outdoor air temp. (°CDB)	Indoor air temperature											
		17.0°CWB		18.0°CWB		19.0°CWB		20.0°CWB		21.0°CWB		22.0°CWB	
		TC	SHC	TC	SHC	TC	SHC	TC	SHC	TC	SHC	TC	SHC
20	27	9.32	6.71	9.59	6.74	9.85	6.76	10.04	6.75	10.31	6.76	10.57	6.76
	29	9.11	6.61	9.38	6.64	9.65	6.67	9.88	6.68	10.10	6.67	10.37	6.69
	31	8.89	6.51	9.16	6.55	9.43	6.58	9.70	6.60	9.92	6.60	10.15	6.60
	33	8.66	6.40	8.95	6.45	9.22	6.49	9.49	6.52	9.76	6.54	9.95	6.53
	35	8.37	6.27	8.73	6.36	9.00	6.39	9.27	6.43	9.54	6.45	9.81	6.47
	37	8.15	6.17	8.44	6.23	8.78	6.30	9.05	6.34	9.32	6.37	9.59	6.39
	39	7.88	6.05	8.21	6.13	8.51	6.19	8.84	6.25	9.11	6.28	9.38	6.31

Model FDT1001HKXE2

Air flow (m ³ /min)	Outdoor air temp. (°CDB)	Indoor air temperature											
		17.0°CWB		18.0°CWB		19.0°CWB		20.0°CWB		21.0°CWB		22.0°CWB	
		TC	SHC	TC	SHC	TC	SHC	TC	SHC	TC	SHC	TC	SHC
28	27	11.60	8.72	11.94	8.77	12.25	8.80	12.50	8.80	12.84	8.83	13.15	8.84
	29	11.33	8.60	11.67	8.66	12.01	8.70	12.30	8.72	12.57	8.72	12.90	8.75
	31	11.07	8.48	11.40	8.54	11.74	8.59	12.07	8.63	12.34	8.64	12.63	8.65
	33	10.77	8.35	11.13	8.42	11.47	8.48	11.80	8.52	12.14	8.56	12.39	8.56
	35	10.42	8.20	10.86	8.31	11.20	8.37	11.54	8.42	11.87	8.46	12.21	8.49
	37	10.15	8.08	10.51	8.16	10.93	8.26	11.27	8.31	11.60	8.36	11.94	8.39
	39	9.81	7.93	10.21	8.04	10.60	8.12	11.00	8.20	11.33	8.26	11.67	8.30

Model FDT1251HKXE2

Air flow (m ³ /min)	Outdoor air temp. (°CDB)	Indoor air temperature											
		17.0°CWB		18.0°CWB		19.0°CWB		20.0°CWB		21.0°CWB		22.0°CWB	
		TC	SHC	TC	SHC	TC	SHC	TC	SHC	TC	SHC	TC	SHC
30	27	14.50	10.31	14.92	10.36	15.32	10.38	15.62	10.36	16.04	10.38	16.44	10.38
	29	14.17	10.15	14.59	10.20	15.01	10.25	15.37	10.25	15.71	10.24	16.13	10.25
	31	13.83	9.99	14.25	10.05	14.67	10.10	15.09	10.13	15.43	10.13	15.79	10.12
	33	13.47	9.82	13.92	9.90	14.34	9.95	14.76	9.99	15.18	10.02	15.48	10.00
	35	13.02	9.62	13.58	9.75	14.00	9.81	14.42	9.85	14.84	9.89	15.26	9.92
	37	12.68	9.46	13.13	9.55	13.66	9.66	14.08	9.71	14.50	9.76	14.92	9.79
	39	12.26	9.27	12.77	9.39	13.24	9.48	13.75	9.57	14.17	9.62	14.59	9.66

Note (1) Symbols are as follows :

TC : Total cooling capacity (kW)

SHC : Sensible heat capacity (kW)

(b) FDTW Series**Model FDTW251HKXE2**

Air flow (m ³ /min)	Outdoor air temp. (°CDB)	Indoor air temperature											
		17.0°CWB		18.0°CWB		19.0°CWB		20.0°CWB		21.0°CWB		22.0°CWB	
		TC	SHC	TC	SHC	TC	SHC	TC	SHC	TC	SHC	TC	SHC
15	27	2.90	2.58	2.98	2.60	3.06	2.62	3.12	2.63	3.21	2.64	3.29	2.66
	29	2.83	2.55	2.92	2.57	3.00	2.59	3.07	2.61	3.14	2.62	3.23	2.64
	31	2.77	2.52	2.85	2.55	2.93	2.57	3.02	2.59	3.09	2.60	3.16	2.61
	33	2.69	2.49	2.78	2.52	2.87	2.54	2.95	2.56	3.04	2.58	3.10	2.59
	35	2.60	2.46	2.72	2.49	2.80	2.52	2.88	2.54	2.97	2.56	3.05	2.58
	37	2.54	2.43	2.63	2.46	2.73	2.49	2.82	2.52	2.90	2.54	2.98	2.55
	39	2.45	2.40	2.55	2.43	2.65	2.46	2.75	2.49	2.83	2.51	2.92	2.53

Model FDTW401HKXE2

Air flow (m ³ /min)	Outdoor air temp. (°CDB)	Indoor air temperature											
		17.0°CWB		18.0°CWB		19.0°CWB		20.0°CWB		21.0°CWB		22.0°CWB	
		TC	SHC	TC	SHC	TC	SHC	TC	SHC	TC	SHC	TC	SHC
15	27	4.66	4.00	4.80	4.03	4.92	4.05	5.02	4.06	5.16	4.09	5.28	4.10
	29	4.55	3.95	4.69	3.99	4.82	4.01	4.94	4.03	5.05	4.05	5.18	4.07
	31	4.45	3.91	4.58	3.94	4.72	3.97	4.85	4.00	4.96	4.02	5.08	4.03
	33	4.33	3.86	4.47	3.90	4.61	3.93	4.74	3.96	4.88	3.99	4.98	4.00
	35	4.19	3.80	4.37	3.86	4.50	3.89	4.64	3.92	4.77	3.95	4.91	3.98
	37	4.08	3.76	4.22	3.80	4.39	3.85	4.53	3.88	4.66	3.91	4.80	3.94
	39	3.94	3.70	4.10	3.75	4.26	3.80	4.42	3.84	4.55	3.87	4.69	3.90

Model FDTW501HKXE2

Air flow (m ³ /min)	Outdoor air temp. (°CDB)	Indoor air temperature											
		17.0°CWB		18.0°CWB		19.0°CWB		20.0°CWB		21.0°CWB		22.0°CWB	
		TC	SHC	TC	SHC	TC	SHC	TC	SHC	TC	SHC	TC	SHC
15	27	5.80	4.49	5.97	4.52	6.13	4.53	6.25	4.54	6.24	4.55	6.57	4.56
	29	5.67	4.43	5.84	4.46	6.00	4.48	6.15	4.50	6.28	4.50	6.45	4.52
	31	5.53	4.37	5.70	4.40	5.87	4.43	6.04	4.45	6.17	4.46	6.32	4.47
	33	5.39	4.31	5.57	4.34	5.73	4.37	5.90	4.40	6.07	4.42	6.19	4.42
	35	5.21	4.23	5.43	4.29	5.60	4.32	5.77	4.35	5.94	4.37	6.10	4.39
	37	5.07	4.17	5.25	4.21	5.47	4.27	5.63	4.30	5.80	4.32	5.97	4.34
	39	4.91	4.10	5.11	4.15	5.30	4.20	5.50	4.24	5.67	4.27	5.84	4.30

Model FDTW631HKXE2

Air flow (m ³ /min)	Outdoor air temp. (°CDB)	Indoor air temperature											
		17.0°CWB		18.0°CWB		19.0°CWB		20.0°CWB		21.0°CWB		22.0°CWB	
		TC	SHC	TC	SHC	TC	SHC	TC	SHC	TC	SHC	TC	SHC
16	27	7.36	5.32	7.57	5.35	7.77	5.36	7.92	5.35	8.14	5.36	8.34	5.36
	29	7.19	5.24	7.40	5.27	7.61	5.29	7.80	5.30	7.97	5.29	8.18	5.30
	31	7.01	5.16	7.23	5.19	7.44	5.22	7.65	5.24	7.82	5.24	8.01	5.24
	33	6.83	5.08	7.06	5.12	7.27	5.15	7.48	5.17	7.70	5.19	7.85	5.18
	35	6.60	4.97	6.89	5.04	7.10	5.07	7.31	5.10	7.53	5.12	7.74	5.14
	37	6.43	4.90	6.66	4.94	6.93	5.00	7.14	5.03	7.36	5.05	7.57	5.07
	39	6.22	4.80	6.48	4.86	6.72	4.91	6.97	4.96	7.19	4.99	7.40	5.01

Note (1) Symbols are as follows :

TC : Total cooling capacity (kW)

SHC : Sensible heat capacity (kW)

Model FDTW801HKXE2

Air flow (m ³ /min)	Outdoor air temp. (°CDB)	Indoor air temperature											
		17.0°CWB		18.0°CWB		19.0°CWB		20.0°CWB		21.0°CWB		22.0°CWB	
		TC	SHC	TC	SHC	TC	SHC	TC	SHC	TC	SHC	TC	SHC
19	27	9.32	6.60	9.59	6.63	9.85	6.64	10.04	6.63	10.31	6.64	10.57	6.63
	29	9.11	6.49	9.38	6.53	9.65	6.55	9.88	6.56	10.10	6.55	10.37	6.55
	31	8.89	6.39	9.16	6.43	9.43	6.46	9.70	6.48	9.92	6.47	10.15	6.47
	33	8.66	6.28	8.95	6.33	9.22	6.36	9.49	6.39	9.76	6.41	9.95	6.39
	35	8.37	6.15	8.73	6.23	9.00	6.27	9.27	6.30	9.54	6.32	9.81	6.34
	37	8.15	6.05	8.44	6.10	8.78	6.17	9.05	6.21	9.32	6.23	9.59	6.25
	39	7.88	5.92	8.21	6.00	8.51	6.06	8.84	6.12	9.11	6.15	9.38	6.17

Model FDTW1001HKXE2

Air flow (m ³ /min)	Outdoor air temp. (°CDB)	Indoor air temperature											
		17.0°CWB		18.0°CWB		19.0°CWB		20.0°CWB		21.0°CWB		22.0°CWB	
		TC	SHC	TC	SHC	TC	SHC	TC	SHC	TC	SHC	TC	SHC
28	27	11.60	8.72	11.94	8.77	12.25	8.80	12.50	8.80	12.84	8.83	13.15	8.84
	29	11.33	8.60	11.67	8.66	12.01	8.70	12.30	8.72	12.57	8.72	12.90	8.75
	31	11.07	8.48	11.40	8.54	11.74	8.59	12.07	8.63	12.34	8.64	12.63	8.65
	33	10.77	8.35	11.13	8.42	11.47	8.48	11.80	8.52	12.14	8.56	12.39	8.56
	35	10.42	8.20	10.86	8.31	11.20	8.37	11.54	8.42	11.87	8.46	12.21	8.49
	37	10.15	8.08	10.51	8.16	10.93	8.26	11.27	8.31	11.60	8.36	11.94	8.39
	39	9.81	7.93	10.21	8.04	10.60	8.12	11.00	8.20	11.33	8.26	11.67	8.30

Model FDTW1251HKXE2

Air flow (m ³ /min)	Outdoor air temp. (°CDB)	Indoor air temperature											
		17.0°CWB		18.0°CWB		19.0°CWB		20.0°CWB		21.0°CWB		22.0°CWB	
		TC	SHC	TC	SHC	TC	SHC	TC	SHC	TC	SHC	TC	SHC
30	27	14.50	10.31	14.92	10.36	15.32	10.38	15.62	10.36	16.04	10.38	16.44	10.38
	29	14.17	10.15	14.59	10.20	15.01	10.25	15.37	10.25	15.71	10.24	16.13	10.25
	31	13.83	9.99	14.25	10.05	14.67	10.10	15.09	10.13	15.43	10.13	15.79	10.12
	33	13.47	9.82	13.92	9.90	14.34	9.95	14.76	9.99	15.18	10.02	15.48	10.00
	35	13.02	9.62	13.58	9.75	14.00	9.81	14.42	9.85	14.84	9.89	15.26	9.92
	37	12.68	9.46	13.13	9.55	13.66	9.66	14.08	9.71	14.50	9.76	14.92	9.79
	39	12.26	9.27	12.77	9.39	13.24	9.48	13.75	9.57	14.17	9.62	14.59	9.66

Note (1) Symbols are as follows :

TC : Total cooling capacity (kW)

SHC : Sensible heat capacity (kW)

(c) FDTs Series**Model FDTs251HKXE2**

Air flow (m ³ /min)	Outdoor air temp. (°CDB)	Indoor air temperature											
		17.0°CWB		18.0°CWB		19.0°CWB		20.0°CWB		21.0°CWB		22.0°CWB	
		TC	SHC	TC	SHC	TC	SHC	TC	SHC	TC	SHC	TC	SHC
12	27	2.90	2.58	2.98	2.60	3.06	2.62	3.12	2.63	3.21	2.64	3.29	2.66
	29	2.83	2.55	2.92	2.57	3.00	2.59	3.07	2.61	3.14	2.62	3.23	2.64
	31	2.77	2.52	2.85	2.55	2.93	2.57	3.02	2.59	3.09	2.60	3.16	2.61
	33	2.69	2.49	2.78	2.52	2.87	2.54	2.95	2.56	3.04	2.58	3.10	2.59
	35	2.60	2.46	2.72	2.49	2.80	2.52	2.88	2.54	2.97	2.56	3.05	2.58
	37	2.54	2.43	2.63	2.46	2.73	2.49	2.82	2.52	2.90	2.54	2.98	2.55
	39	2.45	2.40	2.55	2.43	2.65	2.46	2.75	2.49	2.83	2.51	2.92	2.53

Model FDTs321HKXE2

Air flow (m ³ /min)	Outdoor air temp. (°CDB)	Indoor air temperature											
		17.0°CWB		18.0°CWB		19.0°CWB		20.0°CWB		21.0°CWB		22.0°CWB	
		TC	SHC	TC	SHC	TC	SHC	TC	SHC	TC	SHC	TC	SHC
12	27	3.73	3.20	3.84	3.22	3.94	3.24	4.02	3.25	4.13	3.27	4.23	3.28
	29	3.64	3.16	3.75	3.19	3.86	3.21	3.95	3.23	4.04	3.24	4.15	3.26
	31	3.56	3.13	3.66	3.15	3.77	3.18	3.88	3.20	3.97	3.21	4.06	3.23
	33	3.46	3.09	3.58	3.12	3.69	3.15	3.79	3.17	3.90	3.19	3.98	3.20
	35	3.35	3.04	3.49	3.08	3.60	3.11	3.71	3.14	3.82	3.16	3.92	3.18
	37	3.26	3.01	3.38	3.04	3.51	3.08	3.62	3.11	3.73	3.13	3.84	3.15
	39	3.15	2.96	3.28	3.00	3.41	3.04	3.54	3.07	3.64	3.10	3.75	3.12

Model FDTs401HKXE2

Air flow (m ³ /min)	Outdoor air temp. (°CDB)	Indoor air temperature											
		17.0°CWB		18.0°CWB		19.0°CWB		20.0°CWB		21.0°CWB		22.0°CWB	
		TC	SHC	TC	SHC	TC	SHC	TC	SHC	TC	SHC	TC	SHC
14	27	4.66	3.86	4.80	3.89	4.92	3.91	5.02	3.92	5.16	3.94	5.28	3.95
	29	4.55	3.82	4.69	3.85	4.82	3.87	4.94	3.89	5.05	3.90	5.18	3.92
	31	4.45	3.77	4.58	3.80	4.72	3.83	4.85	3.85	5.06	3.87	5.08	3.88
	33	4.33	3.72	4.47	3.76	4.61	3.79	4.74	3.81	4.88	3.84	4.98	3.85
	35	4.19	3.66	4.37	3.71	4.50	3.75	4.64	3.77	4.77	3.80	4.91	3.82
	37	4.08	3.62	4.22	3.66	4.39	3.70	4.53	3.73	4.66	3.76	4.80	3.78
	39	3.94	3.56	4.10	3.61	4.26	3.65	4.42	3.69	4.55	3.72	4.69	3.75

Model FDTs631HKXE2

Air flow (m ³ /min)	Outdoor air temp. (°CDB)	Indoor air temperature											
		17.0°CWB		18.0°CWB		19.0°CWB		20.0°CWB		21.0°CWB		22.0°CWB	
		TC	SHC	TC	SHC	TC	SHC	TC	SHC	TC	SHC	TC	SHC
18	27	7.36	5.56	7.57	5.59	7.77	5.61	7.92	5.61	8.14	5.63	8.34	5.64
	29	7.19	5.49	7.40	5.52	7.61	5.55	7.80	5.56	7.97	5.57	8.18	5.58
	31	7.01	5.41	7.23	5.45	7.44	5.48	7.65	5.50	7.82	5.51	8.01	5.52
	33	6.83	5.33	7.06	5.37	7.27	5.41	7.48	5.44	7.70	5.46	7.85	5.46
	35	6.60	5.23	6.89	5.30	7.10	5.34	7.31	5.37	7.53	5.40	7.74	5.42
	37	6.43	5.15	6.66	5.21	6.93	5.27	7.14	5.30	7.36	5.33	7.57	5.36
	39	6.22	5.06	6.48	5.13	6.72	5.18	6.97	5.24	7.19	5.27	7.40	5.30

Note (1) Symbols are as follows :

TC : Total cooling capacity (kW)

SHC : Sensible heat capacity (kW)

(d) FDR Series**Model FDR201HKXE2**

Air flow (m ³ /min)	Outdoor air temp. (°CDB)	Indoor air temperature											
		17.0°CWB		18.0°CWB		19.0°CWB		20.0°CWB		21.0°CWB		22.0°CWB	
		TC	SHC	TC	SHC	TC	SHC	TC	SHC	TC	SHC	TC	SHC
10	27	2.28	2.05	2.35	2.06	2.41	2.08	2.46	2.09	2.52	2.10	2.58	2.11
	29	2.23	2.02	2.29	2.04	2.36	2.06	2.42	2.07	2.47	2.08	2.53	2.09
	31	2.17	2.00	2.24	2.02	2.31	2.04	2.37	2.06	2.42	2.06	2.48	2.08
	33	2.12	1.98	2.19	2.00	2.25	2.02	2.32	2.04	2.38	2.05	2.43	2.06
	35	2.05	1.95	2.13	1.98	2.20	2.00	2.27	2.02	2.33	2.03	2.40	2.05
	37	1.99	1.93	2.06	1.95	2.15	1.98	2.21	2.00	2.28	2.01	2.35	2.03
	39	1.93	1.90	2.01	1.93	2.08	1.96	2.16	1.98	2.23	2.00	2.29	2.01

Model FDR251HKXE2

Air flow (m ³ /min)	Outdoor air temp. (°CDB)	Indoor air temperature											
		17.0°CWB		18.0°CWB		19.0°CWB		20.0°CWB		21.0°CWB		22.0°CWB	
		TC	SHC	TC	SHC	TC	SHC	TC	SHC	TC	SHC	TC	SHC
12	27	2.90	2.58	2.98	2.60	3.06	2.62	3.12	2.63	3.21	2.64	3.29	2.66
	29	2.83	2.55	2.92	2.57	3.00	2.59	3.07	2.61	3.14	2.62	3.23	2.64
	31	2.77	2.52	2.85	2.55	2.93	2.57	3.02	2.59	3.09	2.60	3.16	2.61
	33	2.69	2.49	2.78	2.52	2.87	2.54	2.95	2.56	3.04	2.58	3.10	2.59
	35	2.60	2.46	2.72	2.49	2.80	2.52	2.88	2.54	2.97	2.56	3.05	2.58
	37	2.54	2.43	2.63	2.46	2.73	2.49	2.82	2.52	2.90	2.54	2.98	2.55
	39	2.45	2.40	2.55	2.43	2.65	2.46	2.75	2.49	2.83	2.51	2.92	2.53

Model FDR401HKXE2

Air flow (m ³ /min)	Outdoor air temp. (°CDB)	Indoor air temperature											
		17.0°CWB		18.0°CWB		19.0°CWB		20.0°CWB		21.0°CWB		22.0°CWB	
		TC	SHC	TC	SHC	TC	SHC	TC	SHC	TC	SHC	TC	SHC
14	27	4.66	3.86	4.80	3.89	4.92	3.91	5.02	3.92	5.16	3.94	5.28	3.95
	29	4.55	3.82	4.69	3.85	4.82	3.87	4.94	3.89	5.05	3.90	5.18	3.92
	31	4.45	3.77	4.58	3.80	4.72	3.83	4.85	3.85	4.96	3.87	5.08	3.88
	33	4.33	3.72	4.47	3.76	4.61	3.79	4.74	3.81	4.88	3.84	4.98	3.85
	35	4.19	3.66	4.37	3.71	4.50	3.75	4.64	3.77	4.77	3.80	4.91	3.82
	37	4.08	3.62	4.22	3.66	4.39	3.70	4.53	3.73	4.66	3.76	4.80	3.78
	39	3.94	3.56	4.10	3.61	4.26	3.65	4.42	3.69	4.55	3.72	4.69	3.75

Model FDR501HKXE2

Air flow (m ³ /min)	Outdoor air temp. (°CDB)	Indoor air temperature											
		17.0°CWB		18.0°CWB		19.0°CWB		20.0°CWB		21.0°CWB		22.0°CWB	
		TC	SHC	TC	SHC	TC	SHC	TC	SHC	TC	SHC	TC	SHC
14	27	5.80	4.36	5.97	4.39	6.13	4.40	6.25	4.40	6.42	4.41	6.57	4.42
	29	5.67	4.30	5.84	4.33	6.00	4.35	6.15	4.36	6.28	4.36	6.45	4.37
	31	5.53	4.24	5.70	4.27	5.87	4.29	6.04	4.32	6.17	4.32	6.32	4.32
	33	5.39	4.18	5.57	4.21	5.73	4.24	5.90	4.26	6.07	4.28	6.19	4.28
	35	5.21	4.10	5.43	4.16	5.60	4.18	5.77	4.21	5.94	4.23	6.10	4.25
	37	5.07	4.04	5.25	4.08	5.47	4.13	5.63	4.16	5.80	4.18	5.97	4.20
	39	4.91	3.97	5.11	4.02	5.30	4.06	5.50	4.10	5.67	4.13	5.84	4.15

Note (1) Symbols are as follows :

TC : Total cooling capacity (kW)

SHC : Sensible heat capacity (kW)

Model FDR631HKXE2

Air flow (m ³ /min)	Outdoor air temp. (°CDB)	Indoor air temperature											
		17.0°CWB		18.0°CWB		19.0°CWB		20.0°CWB		21.0°CWB		22.0°CWB	
		TC	SHC	TC	SHC	TC	SHC	TC	SHC	TC	SHC	TC	SHC
18	27	7.36	5.56	7.57	5.59	7.77	5.61	7.92	5.61	8.14	5.63	8.34	5.64
	29	7.19	5.49	7.40	5.52	7.61	5.55	7.80	5.56	7.97	5.57	8.18	5.58
	31	7.01	5.41	7.23	5.45	7.44	5.48	7.65	5.50	7.82	5.51	8.01	5.52
	33	6.83	5.33	7.06	5.37	7.27	5.41	7.48	5.44	7.70	5.46	7.85	5.46
	35	6.60	5.23	6.89	5.30	7.10	5.34	7.31	5.37	7.53	5.40	7.74	5.42
	37	6.43	5.15	6.66	5.21	6.93	5.27	7.14	5.30	7.36	5.33	7.57	5.36
	39	6.22	5.06	6.48	5.13	6.72	5.18	6.97	5.24	7.19	5.27	7.40	5.30

Model FDR801HKXE2

Air flow (m ³ /min)	Outdoor air temp. (°CDB)	Indoor air temperature											
		17.0°CWB		18.0°CWB		19.0°CWB		20.0°CWB		21.0°CWB		22.0°CWB	
		TC	SHC	TC	SHC	TC	SHC	TC	SHC	TC	SHC	TC	SHC
20	27	9.32	6.71	9.59	6.74	9.85	6.76	10.04	6.75	10.31	6.76	10.57	6.76
	29	9.11	6.61	9.38	6.64	9.65	6.67	9.88	6.68	10.10	6.67	10.37	6.69
	31	8.89	6.51	9.16	6.55	9.43	6.58	9.70	6.60	9.92	6.60	10.15	6.60
	33	8.66	6.40	8.95	6.45	9.22	6.49	9.49	6.52	9.76	6.54	9.95	6.53
	35	8.37	6.27	8.73	6.36	9.00	6.39	9.27	6.43	9.54	6.45	9.81	6.47
	37	8.15	6.17	8.44	6.23	8.78	6.30	9.05	6.34	9.32	6.37	9.59	6.39
	39	7.88	6.05	8.21	6.13	8.51	6.19	8.84	6.25	9.11	6.28	9.38	6.31

Model FDR1001HKXE2

Air flow (m ³ /min)	Outdoor air temp. (°CDB)	Indoor air temperature											
		17.0°CWB		18.0°CWB		19.0°CWB		20.0°CWB		21.0°CWB		22.0°CWB	
		TC	SHC	TC	SHC	TC	SHC	TC	SHC	TC	SHC	TC	SHC
28	27	11.60	8.72	11.94	8.77	12.25	8.80	12.50	8.80	12.84	8.83	13.15	8.84
	29	11.33	8.60	11.67	8.66	12.01	8.70	12.30	8.72	12.57	8.72	12.90	8.75
	31	11.07	8.48	11.40	8.54	11.74	8.59	12.07	8.63	12.34	8.64	12.63	8.65
	33	10.77	8.35	11.13	8.42	11.47	8.48	11.80	8.52	12.14	8.56	12.39	8.56
	35	10.42	8.20	10.86	8.31	11.20	8.37	11.54	8.42	11.87	8.46	12.21	8.49
	37	10.15	8.08	10.51	8.16	10.93	8.26	11.27	8.31	11.60	8.36	11.94	8.39
	39	9.81	7.93	10.21	8.04	10.60	8.12	11.00	8.20	11.33	8.26	11.67	8.30

Model FDR1251HKXE2

Air flow (m ³ /min)	Outdoor air temp. (°CDB)	Indoor air temperature											
		17.0°CWB		18.0°CWB		19.0°CWB		20.0°CWB		21.0°CWB		22.0°CWB	
		TC	SHC	TC	SHC	TC	SHC	TC	SHC	TC	SHC	TC	SHC
34	27	14.50	10.78	14.92	10.84	15.32	10.88	15.62	10.87	16.04	10.90	16.44	10.91
	29	14.17	10.63	14.59	10.69	15.01	10.75	15.37	10.77	15.71	10.77	16.13	10.80
	31	13.83	10.48	14.25	10.55	14.67	10.60	15.09	10.65	15.43	10.66	15.79	10.67
	33	13.47	10.31	13.92	10.40	14.34	10.46	14.76	10.52	15.18	10.56	15.48	10.56
	35	13.02	10.12	13.58	10.26	14.00	10.32	14.42	10.38	14.84	10.43	15.26	10.47
	37	12.68	9.97	13.13	10.07	13.66	10.19	14.08	10.25	14.50	10.30	14.92	10.35
	39	12.26	9.78	12.77	9.91	13.24	10.01	13.75	10.12	14.17	10.18	14.59	10.23

Note (1) Symbols are as follows :

TC : Total cooling capacity (kW)

SHC : Sensible heat capacity (kW)

(e) FDUM Series**Model FDUM321HKXE2**

Air flow (m ³ /min)	Outdoor air temp. (°CDB)	Indoor air temperature											
		17.0°CWB		18.0°CWB		19.0°CWB		20.0°CWB		21.0°CWB		22.0°CWB	
		TC	SHC	TC	SHC	TC	SHC	TC	SHC	TC	SHC	TC	SHC
12	27	3.73	3.20	3.84	3.22	3.94	3.24	4.02	3.25	4.13	3.27	4.23	3.28
	29	3.64	3.16	3.75	3.19	3.86	3.21	3.95	3.23	4.04	3.24	4.15	3.26
	31	3.56	3.13	3.66	3.15	3.77	3.18	3.88	3.20	3.97	3.21	4.06	3.23
	33	3.46	3.09	3.58	3.12	3.69	3.15	3.79	3.17	3.90	3.19	3.98	3.20
	35	3.35	3.04	3.49	3.08	3.60	3.11	3.71	3.14	3.82	3.16	3.92	3.18
	37	3.26	3.01	3.38	3.04	3.51	3.08	3.62	3.11	3.73	3.13	3.84	3.15
	39	3.15	2.96	3.28	3.00	3.41	3.04	3.54	3.07	3.64	3.10	3.75	3.12

Model FDUM401HKXE2

Air flow (m ³ /min)	Outdoor air temp. (°CDB)	Indoor air temperature											
		17.0°CWB		18.0°CWB		19.0°CWB		20.0°CWB		21.0°CWB		22.0°CWB	
		TC	SHC	TC	SHC	TC	SHC	TC	SHC	TC	SHC	TC	SHC
14	27	4.66	3.86	4.80	3.89	4.92	3.91	5.02	3.92	5.16	3.94	5.28	3.95
	29	4.55	3.82	4.69	3.85	4.82	3.87	4.94	3.89	5.05	3.90	5.18	3.92
	31	4.45	3.77	4.58	3.80	4.72	3.83	4.85	3.85	4.96	3.87	5.08	3.88
	33	4.33	3.72	4.47	3.76	4.61	3.79	4.74	3.81	4.88	3.84	4.98	3.85
	35	4.19	3.66	4.37	3.71	4.50	3.75	4.64	3.77	4.77	3.80	4.91	3.82
	37	4.08	3.62	4.22	3.66	4.39	3.70	4.53	3.73	4.66	3.76	4.80	3.78
	39	3.94	3.56	4.10	3.61	4.26	3.65	4.42	3.69	4.55	3.72	4.69	3.75

Model FDUM501HKXE2

Air flow (m ³ /min)	Outdoor air temp. (°CDB)	Indoor air temperature											
		17.0°CWB		18.0°CWB		19.0°CWB		20.0°CWB		21.0°CWB		22.0°CWB	
		TC	SHC	TC	SHC	TC	SHC	TC	SHC	TC	SHC	TC	SHC
14	27	5.80	4.36	5.97	4.39	6.13	4.40	6.25	4.40	6.42	4.41	6.57	4.42
	29	5.67	4.30	5.84	4.33	6.00	4.35	6.15	4.36	6.28	4.36	6.45	4.37
	31	5.53	4.24	5.70	4.27	5.87	4.29	6.04	4.32	6.17	4.32	6.32	4.32
	33	5.39	4.18	5.57	4.21	5.73	4.24	5.90	4.26	6.07	4.28	6.19	4.28
	35	5.21	4.10	5.43	4.16	5.60	4.18	5.77	4.21	5.94	4.23	6.10	4.25
	37	5.07	4.04	5.25	4.08	5.47	4.13	5.63	4.16	5.80	4.18	5.97	4.20
	39	4.91	3.97	5.11	4.02	5.30	4.06	5.50	4.10	5.67	4.13	5.84	4.15

Model FDUM631HKXE2

Air flow (m ³ /min)	Outdoor air temp. (°CDB)	Indoor air temperature											
		17.0°CWB		18.0°CWB		19.0°CWB		20.0°CWB		21.0°CWB		22.0°CWB	
		TC	SHC	TC	SHC	TC	SHC	TC	SHC	TC	SHC	TC	SHC
18	27	7.36	5.56	7.57	5.59	7.77	5.61	7.92	5.61	8.14	5.63	8.34	5.64
	29	7.19	5.49	7.40	5.52	7.61	5.55	7.80	5.56	7.97	5.57	8.18	5.58
	31	7.01	5.41	7.23	5.45	7.44	5.48	7.65	5.50	7.82	5.51	8.01	5.52
	33	6.83	5.33	7.06	5.37	7.27	5.41	7.48	5.44	7.70	5.46	7.85	5.46
	35	6.60	5.23	6.89	5.30	7.10	5.34	7.31	5.37	7.53	5.40	7.74	5.42
	37	6.43	5.15	6.66	5.21	6.93	5.27	7.14	5.30	7.36	5.33	7.57	5.36
	39	6.22	5.06	6.48	5.13	6.72	5.18	6.97	5.24	7.19	5.27	7.40	5.30

Note (1) Symbols are as follows :

TC : Total cooling capacity (kW)

SHC : Sensible heat capacity (kW)

Model FDUM801HKXE2

Air flow (m ³ /min)	Outdoor air temp. (°CDB)	Indoor air temperature											
		17.0°CWB		18.0°CWB		19.0°CWB		20.0°CWB		21.0°CWB		22.0°CWB	
		TC	SHC	TC	SHC	TC	SHC	TC	SHC	TC	SHC	TC	SHC
20	27	9.32	6.71	9.59	6.74	9.85	6.76	10.04	6.75	10.31	6.76	10.57	6.76
	29	9.11	6.61	9.38	6.64	9.65	6.67	9.88	6.68	10.10	6.67	10.37	6.69
	31	8.89	6.51	9.16	6.55	9.43	6.58	9.70	6.60	9.92	6.60	10.15	6.60
	33	8.66	6.40	8.95	6.45	9.22	6.49	9.49	6.52	9.76	6.54	9.95	6.53
	35	8.37	6.27	8.73	6.36	9.00	6.39	9.27	6.43	9.54	6.45	9.81	6.47
	37	8.15	6.17	8.44	6.23	8.78	6.30	9.05	6.34	9.32	6.37	9.59	6.39
	39	7.88	6.05	8.21	6.13	8.51	6.19	8.84	6.25	9.11	6.28	9.38	6.31

Model FDUM1001HKXE2

Air flow (m ³ /min)	Outdoor air temp. (°CDB)	Indoor air temperature											
		17.0°CWB		18.0°CWB		19.0°CWB		20.0°CWB		21.0°CWB		22.0°CWB	
		TC	SHC	TC	SHC	TC	SHC	TC	SHC	TC	SHC	TC	SHC
28	27	11.60	8.72	11.94	8.77	12.25	8.80	12.50	8.80	12.84	8.83	13.15	8.84
	29	11.33	8.60	11.67	8.66	12.01	8.70	12.30	8.72	12.57	8.72	12.90	8.75
	31	11.07	8.48	11.40	8.54	11.74	8.59	12.07	8.63	12.34	8.64	12.63	8.65
	33	10.77	8.35	11.13	8.42	11.47	8.48	11.80	8.52	12.14	8.56	12.39	8.56
	35	10.42	8.20	10.86	8.31	11.20	8.37	11.54	8.42	11.87	8.46	12.21	8.49
	37	10.15	8.08	10.51	8.16	10.93	8.26	11.27	8.31	11.60	8.36	11.94	8.39
	39	9.81	7.93	10.21	8.04	10.60	8.12	11.00	8.20	11.33	8.26	11.67	8.30

Model FDUM1251HKXE2

Air flow (m ³ /min)	Outdoor air temp. (°CDB)	Indoor air temperature											
		17.0°CWB		18.0°CWB		19.0°CWB		20.0°CWB		21.0°CWB		22.0°CWB	
		TC	SHC	TC	SHC	TC	SHC	TC	SHC	TC	SHC	TC	SHC
34	27	14.50	10.78	14.92	10.84	15.32	10.88	15.62	10.87	16.04	10.90	16.44	10.91
	29	14.17	10.63	14.59	10.69	15.01	10.75	15.37	10.77	15.71	10.77	16.13	10.80
	31	13.83	10.48	14.25	10.55	14.67	10.60	15.09	10.65	15.43	10.66	15.79	10.67
	33	13.47	10.31	13.92	10.40	14.34	10.46	14.76	10.52	15.18	10.56	15.48	10.56
	35	13.02	10.12	13.58	10.26	14.00	10.32	14.42	10.38	14.84	10.43	15.26	10.47
	37	12.68	9.97	13.13	10.07	13.66	10.19	14.08	10.25	14.50	10.30	14.92	10.35
	39	12.26	9.78	12.77	9.91	13.24	10.01	13.75	10.12	14.17	10.18	14.59	10.23

Note (1) Symbols are as follows :

TC : Total cooling capacity (kW)

SHC : Sensible heat capacity (kW)

(f) FDE Series**Model FDE321HKXE2**

Air flow (m ³ /min)	Outdoor air temp. (°CDB)	Indoor air temperature											
		17.0°CWB		18.0°CWB		19.0°CWB		20.0°CWB		21.0°CWB		22.0°CWB	
		TC	SHC	TC	SHC	TC	SHC	TC	SHC	TC	SHC	TC	SHC
14	27	3.73	3.34	3.84	3.36	3.94	3.39	4.02	3.40	4.13	3.42	4.23	3.44
	29	3.64	3.30	3.75	3.33	3.86	3.36	3.95	3.38	4.04	3.39	4.15	3.41
	31	3.56	3.26	3.66	3.30	3.77	3.32	3.88	3.35	3.97	3.37	4.06	3.38
	33	3.46	3.23	3.58	3.26	3.69	3.29	3.79	3.32	3.90	3.34	3.98	3.35
	35	3.35	3.18	3.49	3.23	3.60	3.26	3.71	3.29	3.82	3.31	3.92	3.34
	37	3.26	3.15	3.38	3.18	3.51	3.23	3.62	3.26	3.73	3.28	3.84	3.31
	39	3.15	3.10	3.28	3.15	3.41	3.19	3.54	3.23	3.64	3.25	3.75	3.28

Model FDE401HKXE2

Air flow (m ³ /min)	Outdoor air temp. (°CDB)	Indoor air temperature											
		17.0°CWB		18.0°CWB		19.0°CWB		20.0°CWB		21.0°CWB		22.0°CWB	
		TC	SHC	TC	SHC	TC	SHC	TC	SHC	TC	SHC	TC	SHC
14	27	4.66	3.86	4.80	3.89	4.92	3.91	5.02	3.92	5.16	3.94	5.28	3.95
	29	4.55	3.82	4.69	3.85	4.82	3.87	4.94	3.89	5.05	3.90	5.18	3.92
	31	4.45	3.77	4.58	3.80	4.72	3.83	4.85	3.85	4.96	3.87	5.08	3.88
	33	4.33	3.72	4.47	3.76	4.61	3.79	4.74	3.81	4.88	3.84	4.98	3.85
	35	4.19	3.66	4.37	3.71	4.50	3.75	4.64	3.77	4.77	3.80	4.91	3.82
	37	4.08	3.62	4.22	3.66	4.39	3.70	4.53	3.73	4.66	3.76	4.80	3.78
	39	3.94	3.56	4.10	3.61	4.26	3.65	4.42	3.69	4.55	3.72	4.69	3.75

Model FDE501HKXE2

Air flow (m ³ /min)	Outdoor air temp. (°CDB)	Indoor air temperature											
		17.0°CWB		18.0°CWB		19.0°CWB		20.0°CWB		21.0°CWB		22.0°CWB	
		TC	SHC	TC	SHC	TC	SHC	TC	SHC	TC	SHC	TC	SHC
14	27	5.80	4.36	5.97	4.39	6.13	4.40	6.25	4.40	6.42	4.41	6.57	4.42
	29	5.67	4.30	5.84	4.33	6.00	4.35	6.15	4.36	6.28	4.36	6.45	4.37
	31	5.53	4.24	5.70	4.27	5.87	4.29	6.04	4.32	6.17	4.32	6.32	4.32
	33	5.39	4.18	5.57	4.21	5.73	4.24	5.90	4.26	6.07	4.28	6.19	4.28
	35	5.21	4.10	5.43	4.16	5.60	4.18	5.77	4.21	5.94	4.23	6.10	4.25
	37	5.07	4.04	5.25	4.08	5.47	4.13	5.63	4.16	5.80	4.18	5.97	4.20
	39	4.91	3.97	5.11	4.02	5.30	4.06	5.50	4.10	5.67	4.13	5.84	4.15

Model FDE631HKXE2

Air flow (m ³ /min)	Outdoor air temp. (°CDB)	Indoor air temperature											
		17.0°CWB		18.0°CWB		19.0°CWB		20.0°CWB		21.0°CWB		22.0°CWB	
		TC	SHC	TC	SHC	TC	SHC	TC	SHC	TC	SHC	TC	SHC
18	27	7.36	5.56	7.57	5.59	7.77	5.61	7.92	5.61	8.14	5.63	8.34	5.64
	29	7.19	5.49	7.40	5.52	7.61	5.55	7.80	5.56	7.97	5.57	8.18	5.58
	31	7.01	5.41	7.23	5.45	7.44	5.48	7.65	5.50	7.82	5.51	8.01	5.52
	33	6.83	5.33	7.06	5.37	7.27	5.41	7.48	5.44	7.70	5.46	7.85	5.46
	35	6.60	5.23	6.89	5.30	7.10	5.34	7.31	5.37	7.53	5.40	7.74	5.42
	37	6.43	5.15	6.66	5.21	6.93	5.27	7.14	5.30	7.36	5.33	7.57	5.36
	39	6.22	5.06	6.48	5.13	6.72	5.18	6.97	5.24	7.19	5.27	7.40	5.30

Note (1) Symbols are as follows :

TC : Total cooling capacity (kW)

SHC : Sensible heat capacity (kW)

Model FDE1001HKXE2

Air flow (m ³ /min)	Outdoor air temp. (°CDB)	Indoor air temperature											
		17.0°CWB		18.0°CWB		19.0°CWB		20.0°CWB		21.0°CWB		22.0°CWB	
		TC	SHC	TC	SHC	TC	SHC	TC	SHC	TC	SHC	TC	SHC
28	27	11.60	8.72	11.94	8.77	12.25	8.80	12.50	8.80	12.84	8.83	13.15	8.84
	29	11.33	8.60	11.67	8.66	12.01	8.70	12.30	8.72	12.57	8.72	12.90	8.75
	31	11.07	8.48	11.40	8.54	11.74	8.59	12.07	8.63	12.34	8.64	12.63	8.65
	33	10.77	8.35	11.13	8.42	11.47	8.48	11.80	8.52	12.14	8.56	12.39	8.56
	35	10.42	8.20	10.86	8.31	11.20	8.37	11.54	8.42	11.87	8.46	12.21	8.49
	37	10.15	8.08	10.51	8.16	10.93	8.26	11.27	8.31	11.60	8.36	11.94	8.39
	39	9.81	7.93	10.21	8.04	10.60	8.12	11.00	8.20	11.33	8.26	11.67	8.30

Model FDE1251HKXE2

Air flow (m ³ /min)	Outdoor air temp. (°CDB)	Indoor air temperature											
		17.0°CWB		18.0°CWB		19.0°CWB		20.0°CWB		21.0°CWB		22.0°CWB	
		TC	SHC	TC	SHC	TC	SHC	TC	SHC	TC	SHC	TC	SHC
34	27	14.50	10.78	14.92	10.84	15.32	10.88	15.62	10.87	16.04	10.90	16.44	10.91
	29	14.17	10.63	14.59	10.69	15.01	10.75	15.37	10.77	15.71	10.77	16.13	10.80
	31	13.83	10.48	14.25	10.55	14.67	10.60	15.09	10.65	15.43	10.66	15.79	10.67
	33	13.47	10.31	13.92	10.40	14.34	10.46	14.76	10.52	15.18	10.56	15.48	10.56
	35	13.02	10.12	13.58	10.26	14.00	10.32	14.42	10.38	14.84	10.43	15.26	10.47
	37	12.68	9.97	13.13	10.07	13.66	10.19	14.08	10.25	14.50	10.30	14.92	10.35
	39	12.26	9.78	12.77	9.91	13.24	10.01	13.75	10.12	14.17	10.18	14.59	10.23

(g) FDFL Series

Model FDFL251HKXE2

Air flow (m ³ /min)	Outdoor air temp. (°CDB)	Indoor air temperature											
		17.0°CWB		18.0°CWB		19.0°CWB		20.0°CWB		21.0°CWB		22.0°CWB	
		TC	SHC	TC	SHC	TC	SHC	TC	SHC	TC	SHC	TC	SHC
12	27	2.90	2.58	2.98	2.60	3.06	2.62	3.12	2.63	3.21	2.64	3.29	2.66
	29	2.83	2.55	2.92	2.57	3.00	2.59	3.07	2.61	3.14	2.62	3.23	2.64
	31	2.77	2.52	2.85	2.55	2.93	2.57	3.02	2.59	3.09	2.60	3.16	2.61
	33	2.69	2.49	2.78	2.52	2.87	2.54	2.95	2.56	3.04	2.58	3.10	2.59
	35	2.60	2.46	2.72	2.49	2.80	2.52	2.88	2.54	2.97	2.56	3.05	2.58
	37	2.54	2.43	2.63	2.46	2.73	2.49	2.82	2.52	2.90	2.54	2.98	2.55
	39	2.45	2.40	2.55	2.43	2.65	2.46	2.75	2.49	2.83	2.51	2.92	2.53

Model FDFL401HKXE2

Air flow (m ³ /min)	Outdoor air temp. (°CDB)	Indoor air temperature											
		17.0°CWB		18.0°CWB		19.0°CWB		20.0°CWB		21.0°CWB		22.0°CWB	
		TC	SHC	TC	SHC	TC	SHC	TC	SHC	TC	SHC	TC	SHC
14	27	4.66	3.86	4.80	3.89	4.92	3.91	5.02	3.92	5.16	3.94	5.28	3.95
	29	4.55	3.82	4.69	3.85	4.82	3.87	4.94	3.89	5.05	3.90	5.18	3.92
	31	4.45	3.77	4.58	3.80	4.72	3.83	4.85	3.85	4.96	3.87	5.08	3.88
	33	4.33	3.72	4.47	3.76	4.61	3.79	4.74	3.81	4.88	3.84	4.98	3.85
	35	4.19	3.66	4.37	3.71	4.50	3.75	4.64	3.77	4.77	3.80	4.91	3.82
	37	4.08	3.62	4.22	3.66	4.39	3.70	4.53	3.73	4.66	3.76	4.80	3.78
	39	3.94	3.56	4.10	3.61	4.26	3.65	4.42	3.69	4.55	3.72	4.69	3.75

Note (1) Symbols are as follows :

TC : Total cooling capacity (kW)

SHC : Sensible heat capacity (kW)

Model FDFL631HKXE2

Air flow (m ³ /min)	Outdoor air temp. (°CDB)	Indoor air temperature											
		17.0°CWB		18.0°CWB		19.0°CWB		20.0°CWB		21.0°CWB		22.0°CWB	
		TC	SHC	TC	SHC	TC	SHC	TC	SHC	TC	SHC	TC	SHC
18	27	7.36	5.56	7.57	5.59	7.77	5.61	7.92	5.61	8.14	5.63	8.34	5.64
	29	7.19	5.49	7.40	5.52	7.61	5.55	7.80	5.56	7.97	5.57	8.18	5.58
	31	7.01	5.41	7.23	5.45	7.44	5.48	7.65	5.50	7.82	5.51	8.01	5.52
	33	6.83	5.33	7.06	5.37	7.27	5.41	7.48	5.44	7.70	5.46	7.85	5.46
	35	6.60	5.23	6.89	5.30	7.10	5.34	7.31	5.37	7.53	5.40	7.74	5.42
	37	6.43	5.15	6.66	5.21	6.93	5.27	7.14	5.30	7.36	5.33	7.57	5.36
	39	6.22	5.06	6.48	5.13	6.72	5.18	6.97	5.24	7.19	5.27	7.40	5.30

(h) FDKY Series

Model FDKY251HKXE2

Air flow (m ³ /min)	Outdoor air temp. (°CDB)	Indoor air temperature											
		17.0°CWB		18.0°CWB		19.0°CWB		20.0°CWB		21.0°CWB		22.0°CWB	
		TC	SHC	TC	SHC	TC	SHC	TC	SHC	TC	SHC	TC	SHC
10	27	2.90	2.58	2.98	2.60	3.06	2.62	3.12	2.63	3.21	2.64	3.29	2.66
	29	2.83	2.55	2.92	2.57	3.00	2.59	3.07	2.61	3.14	2.62	3.23	2.64
	31	2.77	2.52	2.85	2.55	2.93	2.57	3.02	2.59	3.09	2.60	3.16	2.61
	33	2.69	2.49	2.78	2.52	2.87	2.54	2.95	2.56	3.04	2.58	3.10	2.59
	35	2.60	2.46	2.72	2.49	2.80	2.52	2.88	2.54	2.97	2.56	3.05	2.58
	37	2.54	2.43	2.63	2.46	2.73	2.49	2.82	2.52	2.90	2.54	2.98	2.55
	39	2.45	2.40	2.55	2.43	2.65	2.46	2.75	2.49	2.83	2.51	2.92	2.53

Model FDKY321HKXE2

Air flow (m ³ /min)	Outdoor air temp. (°CDB)	Indoor air temperature											
		17.0°CWB		18.0°CWB		19.0°CWB		20.0°CWB		21.0°CWB		22.0°CWB	
		TC	SHC	TC	SHC	TC	SHC	TC	SHC	TC	SHC	TC	SHC
10	27	3.73	2.93	3.84	2.95	3.94	2.96	4.02	2.97	4.13	2.98	4.23	2.98
	29	3.64	2.89	3.75	2.91	3.86	2.93	3.95	2.94	4.04	2.95	4.15	2.96
	31	3.56	2.86	3.66	2.88	3.77	2.90	3.88	2.91	3.97	2.92	4.06	2.93
	33	3.46	2.82	3.58	2.84	3.69	2.86	3.79	2.88	3.90	2.86	3.98	2.90
	35	3.35	2.77	3.49	2.81	3.60	2.83	3.71	2.85	3.82	2.83	3.92	2.88
	37	3.26	2.73	3.38	2.76	3.51	2.79	3.62	2.81	3.73	2.80	3.84	2.85
	39	3.15	2.68	3.28	2.72	3.41	2.75	3.54	2.78	3.64	2.79	3.75	2.82

Model FDKY401HKXE2

Air flow (m ³ /min)	Outdoor air temp. (°CDB)	Indoor air temperature											
		17.0°CWB		18.0°CWB		19.0°CWB		20.0°CWB		21.0°CWB		22.0°CWB	
		TC	SHC	TC	SHC	TC	SHC	TC	SHC	TC	SHC	TC	SHC
10	27	4.66	3.54	4.80	3.56	4.92	3.57	5.02	3.57	5.16	3.58	5.28	3.59
	29	4.55	3.49	4.69	3.51	4.82	3.53	4.94	3.54	5.05	3.54	5.18	3.55
	31	4.45	3.44	4.58	3.46	4.72	3.48	4.85	3.50	4.96	3.51	5.08	3.51
	33	4.33	3.39	4.47	3.42	4.61	3.44	4.74	3.46	4.88	3.47	4.98	3.47
	35	4.19	3.33	4.37	3.37	4.50	3.40	4.64	3.42	4.77	3.43	4.91	3.45
	37	4.08	3.28	4.22	3.31	4.39	3.35	4.53	3.37	4.66	3.39	4.80	3.41
	39	3.94	3.22	4.10	3.26	4.26	3.30	4.42	3.33	4.55	3.35	4.69	3.37

Note (1) Symbols are as follows :

TC : Total cooling capacity (kW)

SHC : Sensible heat capacity (kW)

Model FDKY501HKXE2

Air flow (m ³ /min)	Outdoor air temp. (°CDB)	Indoor air temperature											
		17.0°CWB		18.0°CWB		19.0°CWB		20.0°CWB		21.0°CWB		22.0°CWB	
		TC	SHC	TC	SHC	TC	SHC	TC	SHC	TC	SHC	TC	SHC
17	27	5.80	4.75	5.97	4.78	6.13	4.81	6.25	4.82	6.42	4.84	6.57	4.86
	29	5.67	4.69	5.84	4.73	6.00	4.76	6.15	4.78	6.28	4.79	6.45	4.81
	31	5.53	4.64	5.70	4.67	5.87	4.71	6.04	4.74	6.17	4.75	6.32	4.77
	33	5.39	4.57	5.57	4.62	5.73	4.65	5.90	4.69	6.07	4.71	6.19	4.72
	35	5.21	4.50	5.43	4.56	5.60	4.60	5.77	4.64	5.94	4.66	6.10	4.69
	37	5.07	4.44	5.25	4.49	5.47	4.55	5.63	4.59	5.80	4.62	5.97	4.65
	39	4.91	4.37	5.11	4.43	5.30	4.48	5.50	4.54	5.67	4.57	5.84	4.60

Model FDKY631HKXE2

Air flow (m ³ /min)	Outdoor air temp. (°CDB)	Indoor air temperature											
		17.0°CWB		18.0°CWB		19.0°CWB		20.0°CWB		21.0°CWB		22.0°CWB	
		TC	SHC	TC	SHC	TC	SHC	TC	SHC	TC	SHC	TC	SHC
21	27	6.53	5.60	6.72	5.64	6.89	5.67	7.03	5.69	7.22	5.72	7.40	5.75
	29	6.38	5.53	6.56	5.58	6.75	5.62	6.92	5.65	7.07	5.67	7.26	5.70
	31	6.22	5.47	6.41	5.52	6.60	5.56	6.79	5.60	6.94	5.62	7.11	5.65
	33	6.06	5.40	6.26	5.46	6.45	5.50	6.64	5.55	6.83	5.58	6.97	5.60
	35	5.86	5.32	6.11	5.40	6.30	5.45	6.49	5.49	6.68	5.53	6.87	5.57
	37	5.71	5.26	5.91	5.32	6.15	5.39	6.34	5.44	6.53	5.48	6.72	5.51
	39	5.52	5.18	5.75	5.26	5.96	5.32	6.19	5.38	6.38	5.42	6.56	5.46

Note (1) Symbols are as follows :

TC : Total cooling capacity (kW)

SHC : Sensible heat capacity (kW)

(1) INDOOR UNIT

- (a) Ceiling recessed type **(FDT)** Modles All modeles
- (b) 2-Way outlet ceiling recessed type **(FDTW)** Modles All modeles
- (c) 1-Way outlet ceiling recessed type **(FDTS)** Modles All modeles
- (d) Cassetteria type **(FDR)** Modles All modeles
- (e) Satellie ducted type **(FDUM)** Modles All modeles
- (f) Ceiling suspension type **(FDE)** Modles All modeles
- (g) Wall mounted type **(FDKY)** Modles All modeles
- (h) Floor standing type **(FDFL)** Modles All modeles

(2) Individual flow divide controller

(2) OUTDOOR UNIT

Modeles **FDC2001HKXRE2,2501HKXRE2**

2 ELECTRICAL DATA

2.1 Electrical wiring

(1) Indoor unit

(a) Ceiling recessed type (FDT)

Models All models

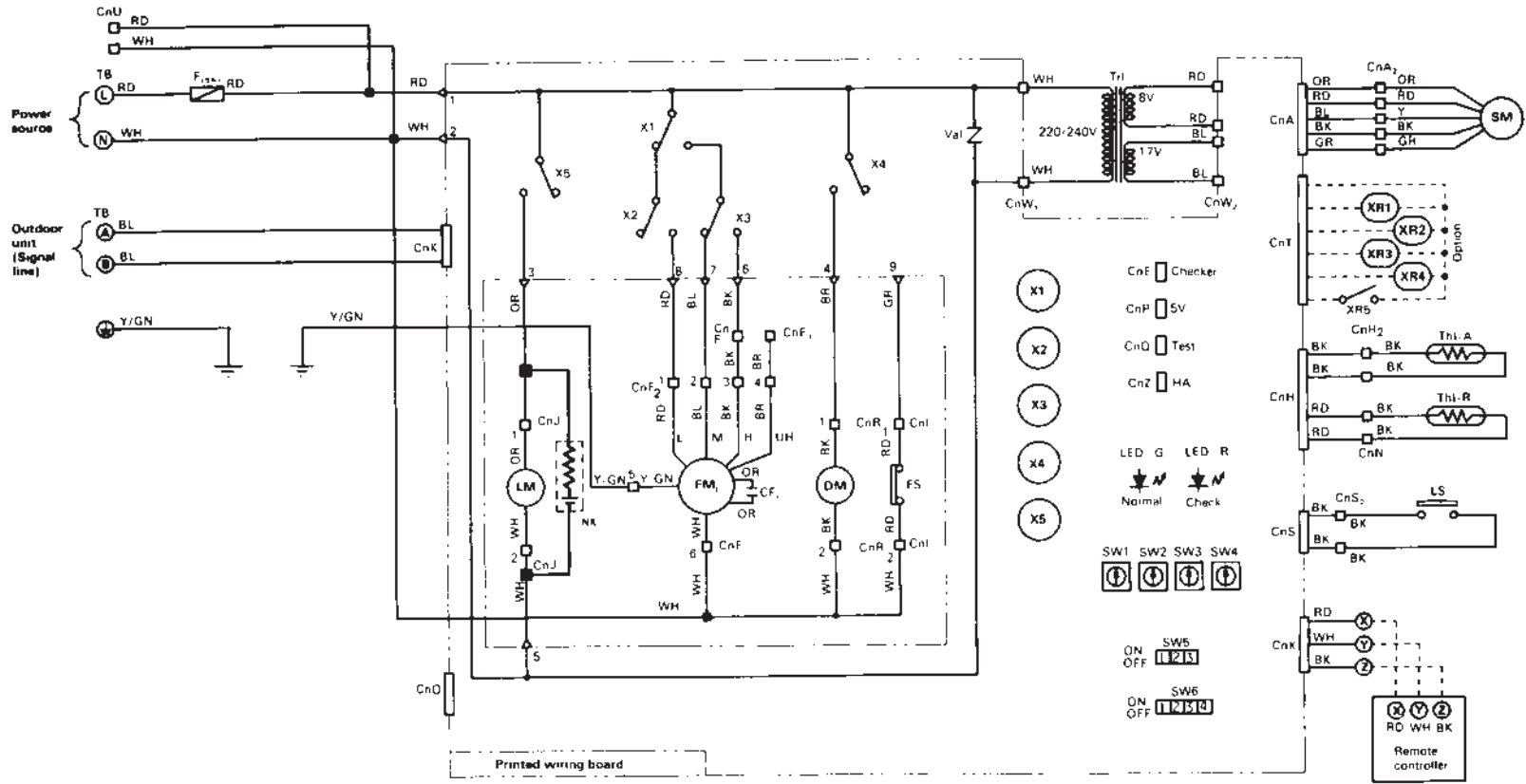

Color mark

Mark	Color	Mark	Color
BK	Black	RD	Red
BL	Blue	WH	White
BR	Brown	Y	Yellow
GR	Gray	Y/GN	Yellow/Green
OR	Orange		

Function of switches

Mark	Function		
SW5-1	ON	Input signal	Reverse Invalid
	OFF		Run Stop
SW5-2	ON	Heating temp. shift + 3°C	
	OFF	Normal	
SW5-3	ON	Invalid filter sign	
	OFF	Valid filter sign	

Meaning of marks

Mark	Parts name	Mark	Parts name	Mark	Parts name
FM ₁	Fan motor	Th1-R	Thermistor	CnA-Z	Connector (□ mark)
CF ₁	Capacitor for FM ₁	SW1	Indoor unit address ten's place	TB	Terminal block
DM	Drain motor	SW2	Indoor unit address unit's place	<mark	Terminal (F)
FS	Float switch (For overflow prevention)	SW3	Outdoor unit address ten's place	■mark	Connector
LM	Louver motor	SW4	Outdoor unit address unit's place	XR1	Operation indication (DC12)
LS	Limit switch	SW6	Change of heat pump type	XR2	Heating indication (DC12)
SM	Stepping motor (For Exp.v)	Tr1	Transformer	XR3	ON indication for CM (DC12)
X1,2,3	Auxiliary relay (For FM ₁)	Val	Varistor	XR4	Check indication (DC12)
X4	Auxiliary relay (For DM)	LED-R	Indication lamp (Red)	XR5	Distant operation
X5	Auxiliary relay (For LM)	LED-G	Indication lamp (Green)	NK	Noise killer
Th1-A	Thermistor	F	Fuse		

(b) 2-way outlet ceiling recessed type (FDTW)
Models All models

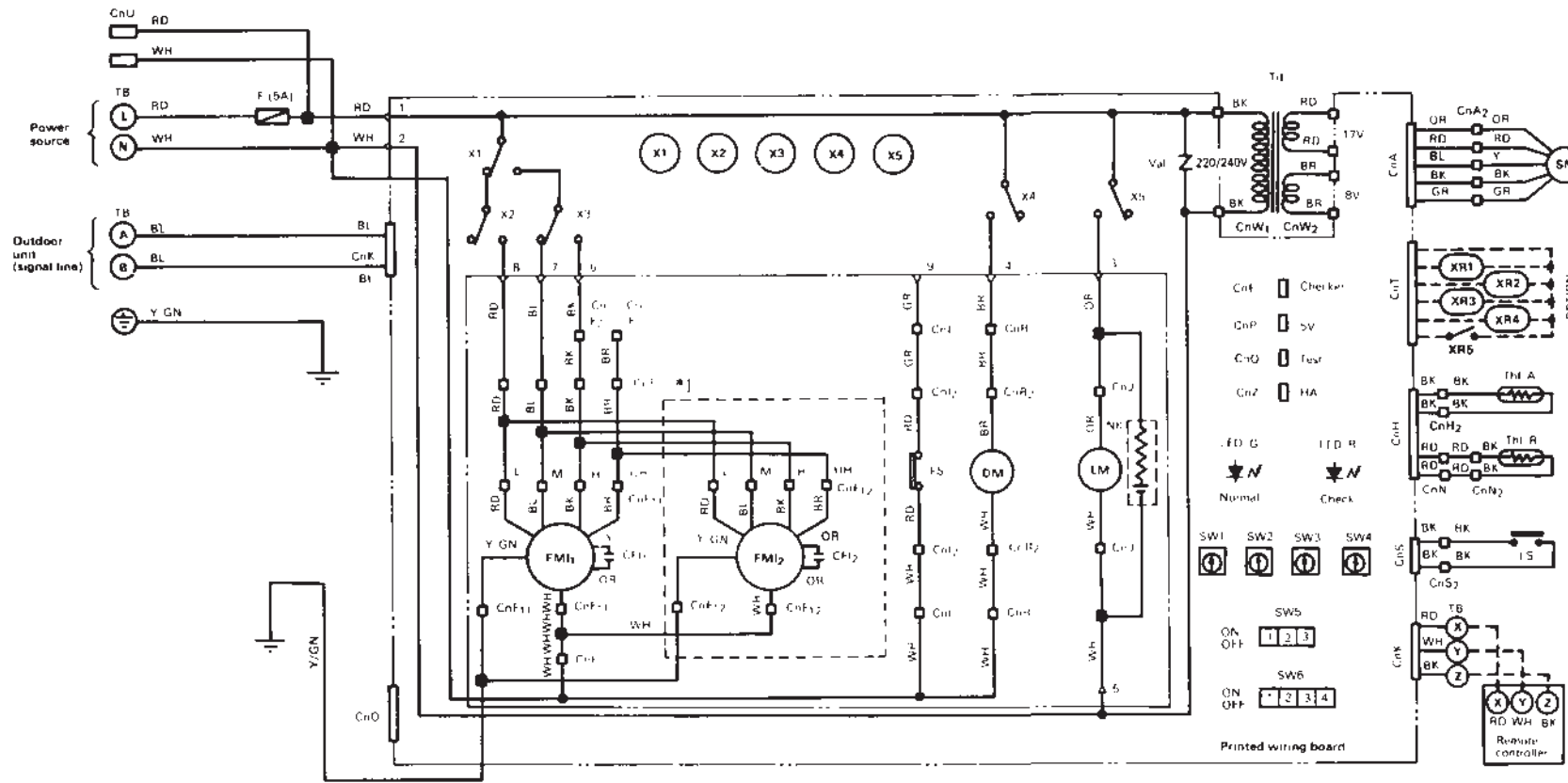

Note: *1 FM₂ is equipped with only for FDTW1001HKXE2, 1251HKXE2

Meaning of marks

Mark	Parts name	Mark	Parts name	Mark	Parts name
FM _{1,2}	Fan motor	Th-I-R	Thermistor	CnA-Z	Connector (□ mark)
CF _{1,2}	Capacitor for FM ₁	SW1	Indoor unit address ten's place	TB	Terminal block
DM	Drain motor	SW2	Indoor unit address unit's place	◁mark	Terminal (F)
FS	Float switch (For overflow prevention)	SW3	Outdoor unit address ten's place	■mark	Connector
LM	Louver motor	SW4	Outdoor unit address unit's place	XR1	Operation indication (DC12)
LS	Limit switch	SW6	Change of heat pump type	XR2	Heating indication (DC12)
SM	Stepping motor (For Exp.v)	Tr1	Transformer	XR3	ON indication for CM (DC15)
X1,2,3	Auxiliary relay (For FM ₁)	Val	Varistor	XR4	Check indication (DC12)
X4	Auxiliary relay (For DM)	LED-R	Indication lamp (Red)	XR5	Distant operation
X5	Auxiliary relay (For LM)	LED-G	Indication lamp (Green)	NK	Noise killer
Th-I-A	Thermistor	F	Fuse		

Color mark

Mark	Color	Mark	Color
BK	Black	RD	Red
BL	Blue	WH	White
BR	Brown	Y	Yellow
GR	Gray	Y/GN	Yellow/Green
OR	Orange		

Function of switches

Mark	Function	
SW5-1	ON	Reverse Invalid
	OFF	Run Stop
SW5-2	ON	Heating temp. shift + 3°C
	OFF	Normal
SW5-3	ON	Invalid filter sign
	OFF	Valid filter sign

(c) 1-way outlet ceiling recessed type (FDTS)
Models All models

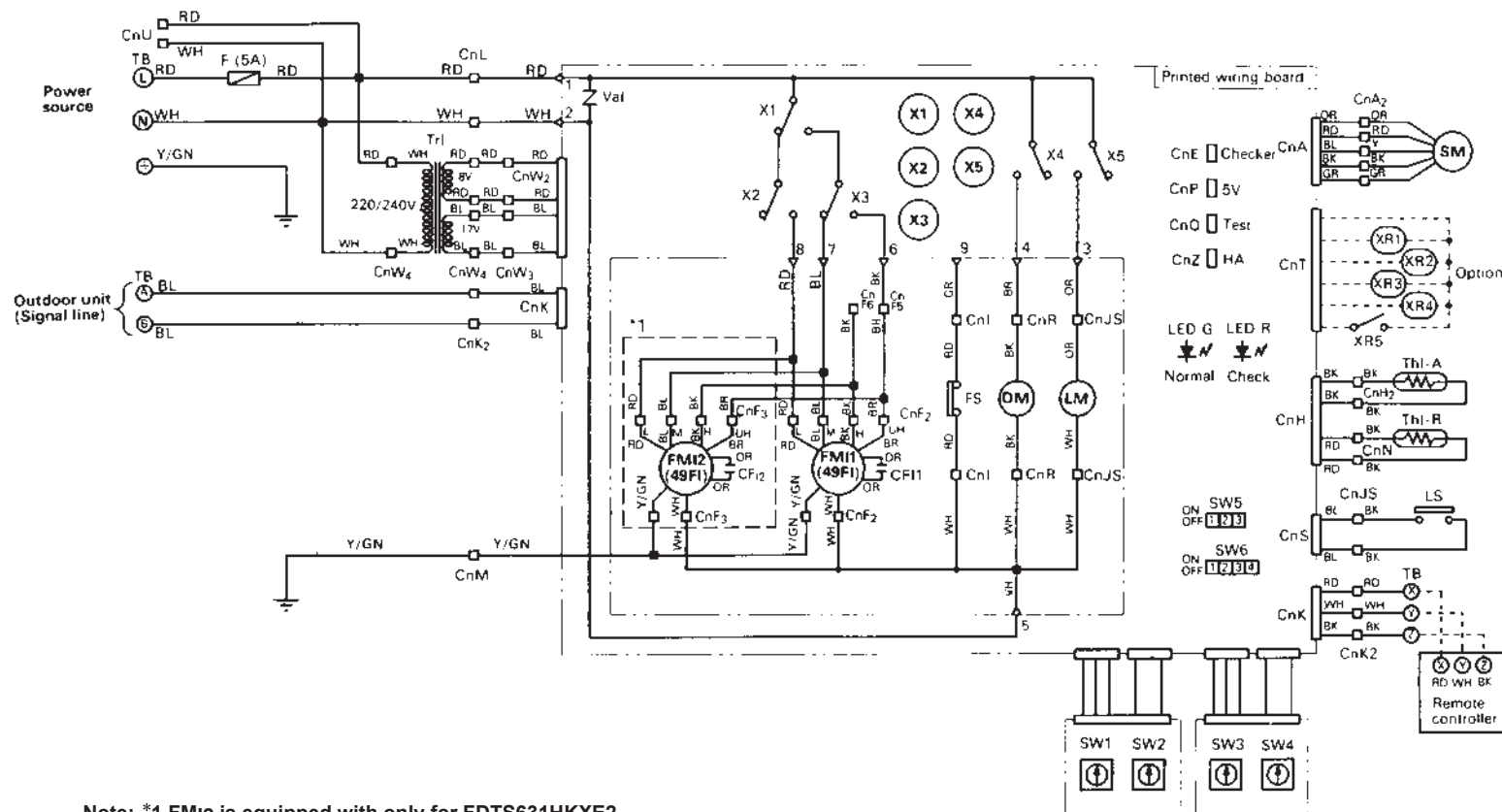

Note: *1 FM₁2 is equipped with only for FDTS631HKXE2

Color mark

Mark	Color	Mark	Color
BK	Black	RD	Red
BL	Blue	WH	White
BR	Brown	Y	Yellow
GR	Gray	Y/GN	Yellow/Green
OR	Orange		

Meaning of marks

Mark	Parts name	Mark	Parts name	Mark	Parts name
FM _{1,2}	Fan motor	Th1-A	Thermistor	F	Fuse
49F ₁	Internal thermostat for FM ₁	Th1-R	Thermistor	CnA-Z	Connector (□ mark)
CF _{1,2}	Capacitor for FM ₁	SW1	Indoor unit address ten's place	TB	Terminal block
DM	Drain motor	SW2	Indoor unit address unit's place	<mark	Terminal (F)
FS	Float switch (For overflow prevention)	SW3	Outdoor unit address ten's place	■ mark	Connector
LM	Louver motor	SW4	Outdoor unit address unit's place	XR1	Operation indication (DC12)
LS	Limit switch	SW6	Change of heat pume type	XR2	Heating indication (DC12)
SM	Stepping motor (For Exp.v)	Tr1	Transformer	XR3	ON indication for CM (DC12)
X1,2,3	Auxiliary relay (For FM ₁)	Val	Varistor	XR4	Check indication (DC12)
X4	Auxiliary relay (For DM)	LED-R	Indication lamp (Red)	XR5	Distant operation
X5	Auxiliary relay (For LM)	LED-G	Indication lamp (Green)		

Function of switches

Mark	Function		
	SW5-1	ON	Input signal
OFF			Run Stop
SW5-2	ON	Heating temp. shift + 3°C	
	OFF	Normal	
SW5-3	ON	Invalid filter sign	
	OFF	Valid filter sign	

(d) Cassetteria type (FDR)
Models All models

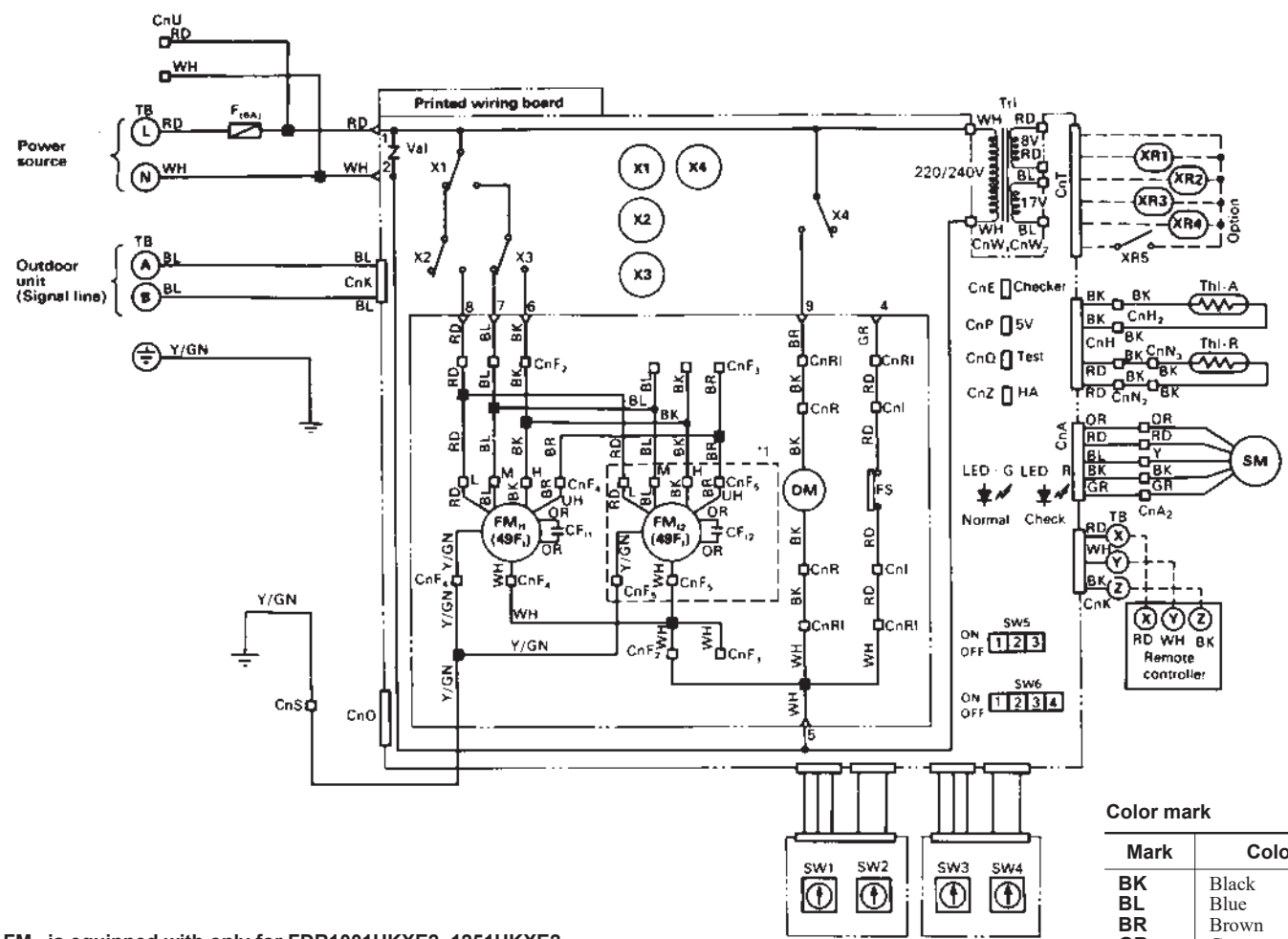

Note: *1 FM₂ is equipped with only for FDR1001HKXE2, 1251HKXE2

Meaning of marks

Mark	Parts name	Mark	Parts name	Mark	Parts name
FM _{1,2}	Fan motor	Thi-R	Thermistor	CnA-Z	Connector (□ mark)
CF _{1,2}	Capacitor for FM ₁	SW1	Indoor unit address ten's place	TB	Terminal block
DM	Drain motor	SW2	Indoor unit address unit's place	<mark	Terminal (F)
FS	Floater switch (For overflow prevention)	SW3	Outdoor unit address ten's place	■ mark	Connector
SM	Stepping motor (For Exp.v)	SW4	Outdoor unit address unit's place	XR1	Operation indication (DC12)
X1,2,3	Auxiliary relay (For FM ₁)	SW6	Change of heat pume type	XR2	Heating indication (DC12)
X4	Auxiliary relay (For DM)	Tr1	Transformer	XR3	ON indication for CM (DC12)
49F ₁	Internal thermostat for FM ₁	Val	Varistor	XR4	Check indication (DC12)
Thi-A	Thermistor	LED-R	Indication lamp (Red)	XR5	Distant operation
		LED-G	Indication lamp (Green)		
		F	Fuse		

Color mark

Mark	Color	Mark	Color
BK	Black	RD	Red
BL	Blue	WH	White
BR	Brown	Y	Yellow
GR	Gray	Y/GN	Yellow/Green
OR	Orange		

Function of switches

Mark	Function		
SW5-1	ON	Input signal	Reverse Invalid
	OFF		Run Stop
SW5-2	ON	Heating temp. shift + 3°C	
	OFF	Normal	
SW5-3	ON	Invalid filter sign	
	OFF	Valid filter sign	

(e) Satellite ducted type (FDUM)
Models All models

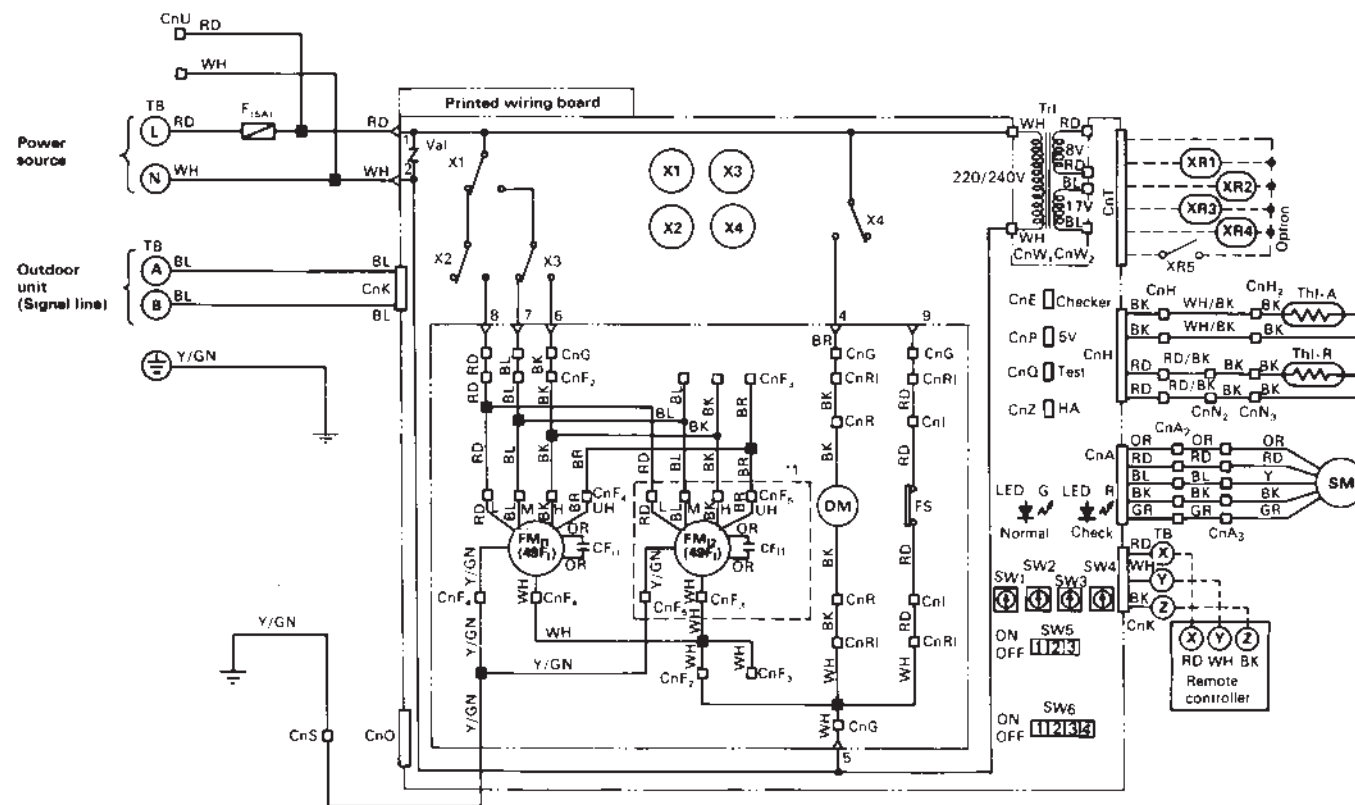

Note: *1 FM₂ is equipped with only for FDUM1001HKXE2, 1251HKXE2

Meaning of marks

Mark	Parts name	Mark	Parts name	Mark	Parts name
FM _{1,2}	Fan motor	Thl-R	Thermistor	CnA-Z	Connector (□ mark)
CF _{1,2}	Capacitor for FM ₁	SW1	Indoor unit address ten's place	TB	Terminal block
DM	Drain motor	SW2	Indoor unit address unit's place	<mark	Terminal (F)
FS	Float switch (For overflow prevention)	SW3	Outdoor unit address ten's place	■mark	Connector
SM	Stepping motor (For Exp.v)	SW4	Outdoor unit address unit's place	XR1	Operation indication (DC12)
X1,2,3	Auxiliary relay (For FM ₁)	SW6	Change of heat pump type	XR2	Heating indication (DC12)
X4	Auxiliary relay (For DM)	Tr1	Transformer	XR3	ON indication for CM (DC12)
49F ₁	Internal thermostat for FM ₁	Val	Varistor	XR4	Check indication (DC12)
Thl-A	Thermistor	LED-R	Indication lamp (Red)	XR5	Distant operation
		LED-G	Indication lamp (Green)		
		F	Fuse		

Color mark

Mark	Color	Mark	Color
BK	Black	RD	Red
BL	Blue	WH	White
BR	Brown	Y	Yellow
GR	Gray	Y/GN	Yellow/Green
OR	Orange		

Function of switches

Mark	Function		
SW5-1	ON	Input signal	Reverse Invalid
	OFF		Run Stop
SW5-2	ON	Heating temp. shift + 3°C	
	OFF	Normal	
SW5-3	ON	Invalid filter sign	
	OFF	Valid filter sign	

(f) Ceiling suspension type (FDE)
Models All models

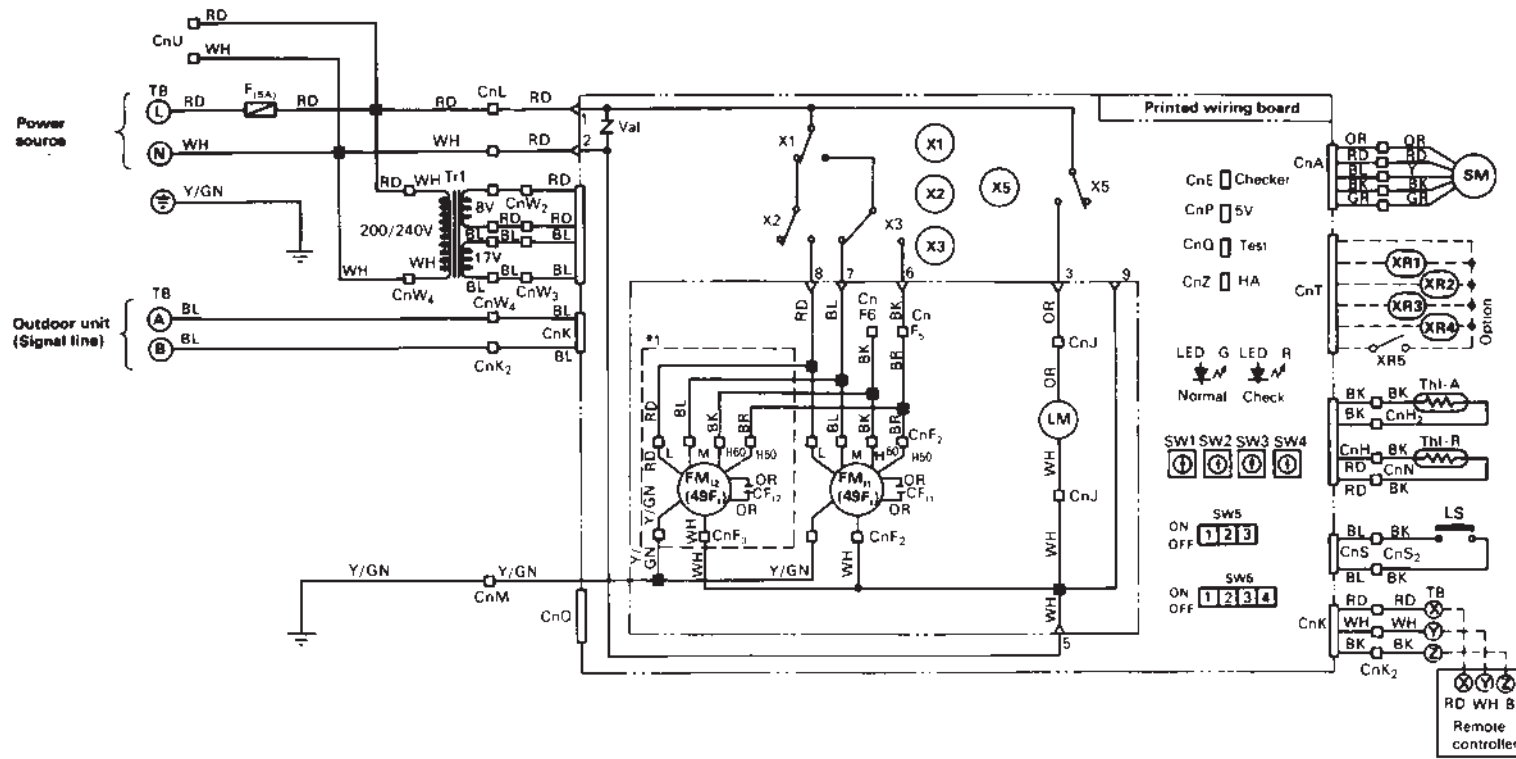

Note: *1 FM₁₂ is equipped with only for FDE631, 1001, 1251 type

Meaning of marks

Mark	Parts name	Mark	Parts name	Mark	Parts name
FM _{1,2}	Fan motor	Thi-R	Thermistor	CnA-Z	Connector (□ mark)
CF _{1,2}	Capacitor for FM ₁	SW1	Indoor unit address ten's place	TB	Terminal block
49F ₁	Internal thermostat for FM ₁	SW2	Indoor unit address unit's place	<mark	Terminal (F)
LM	Louver motor	SW3	Outdoor unit address ten's place	■ mark	Connector
LS	Limit switch	SW4	Outdoor unit address unit's place	XR1	Operation indication (DC12)
SM	Stepping motor (For Exp.v)	SW6	Change of heat pume type	XR2	Heating indication (DC12)
X1,2,3	Auxiliary relay (For FM ₁)	Tr1	Transformer	XR3	ON indication for CM (DC12)
X5	Auxiliary relay (For LM)	Val	Varistor	XR4	Check indication (DC12)
Thi-A	Thermistor	LED-R	Indication lamp (Red)	XR5	Distant operation
		LED-G	Indication lamp (Green)		
		F	Fuse		

Color mark

Mark	Color	Mark	Color
BK	Black	RD	Red
BL	Blue	WH	White
BR	Brown	Y	Yellow
GR	Gray	Y/GN	Yellow/Green
OR	Orange		

Function of switches

Mark	Function		
SW5-1	ON	Input signal	Reverse Invalid
	OFF		Run Stop
SW5-2	ON	Heating temp. shift + 3°C	
	OFF	Normal	
SW5-3	ON	Invalid filter sign	
	OFF	Valid filter sign	

(G) Wall mounted type (FDKY)
Models All models

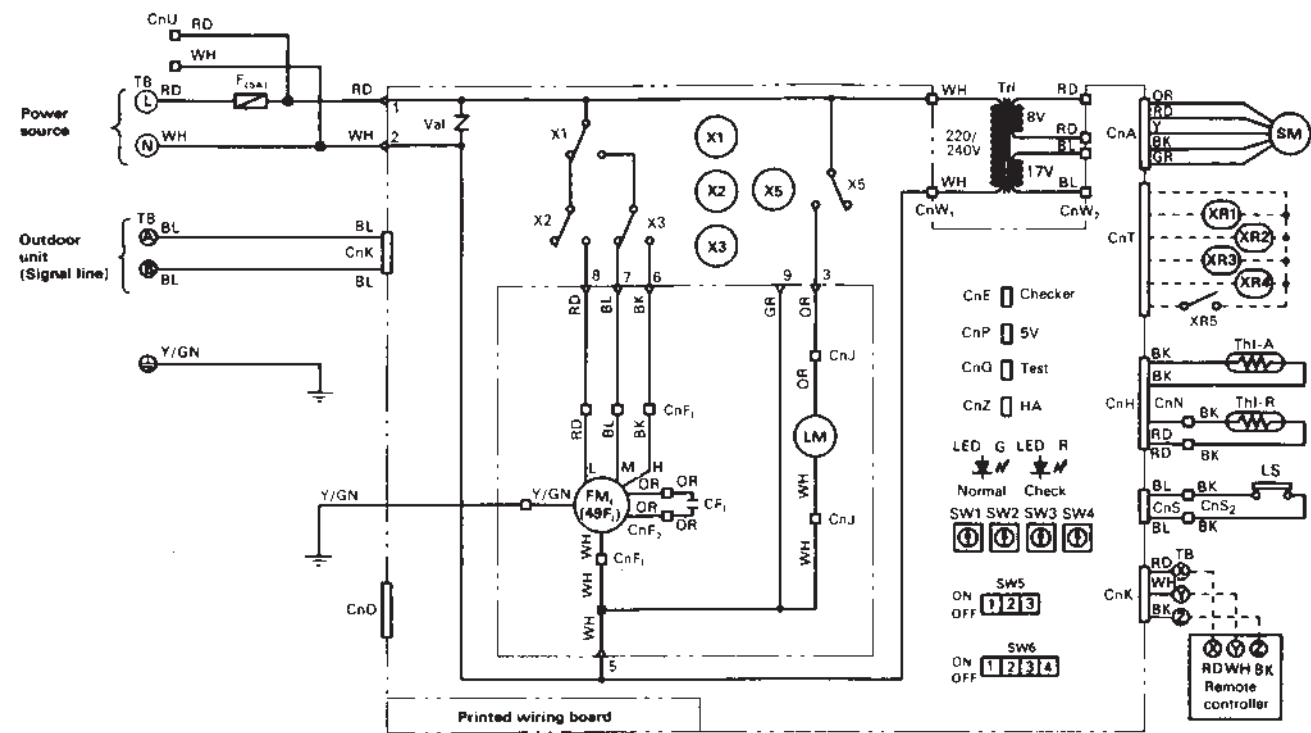

Meaning of marks

Mark	Parts name	Mark	Parts name	Mark	Parts name
FM _{1,2}	Fan motor	Thi-R	Thermistor	CnA-Z	Connector (□ mark)
CF _{1,2}	Capacitor for FM ₁	SW1	Indoor unit address unit's place	TB	Terminal block
49F ₁	Internal thermostat for FM ₁	SW2	Indoor unit address unit's place	<mark	Terminal (F)
LM	Louver motor	SW3	Outdoor unit address ten's place	■ mark	Connector
LS	Limit switch	SW4	Outdoor unit address unit's place	XR1	Operation indication (DC12)
SM	Stepping motor (For Exp.v)	SW6	Change of heat pume type	XR2	Heating indication (DC12)
X1,2,3	Auxiliary relay (For FM ₁)	Tr1	Transformer	XR3	ON indication for CM (DC12)
X5	Auxiliary relay (For LM)	Val	Varistor	XR4	Check indication (DC12)
Thi-A	Thermistor	LED-R	Indication lamp (Red)	XR5	Distant operation
		LED-G	Indication lamp (Green)		
		F	Fuse		

Color mark

Mark	Color	Mark	Color
BK	Black	RD	Red
BL	Blue	WH	White
BR	Brown	Y	Yellow
GR	Gray	Y/GN	Yellow/Green
OR	Orange		

Function of switches

Mark	Function		
SW5-1	ON	Input signal	Reverse Invalid
	OFF		Run Stop
SW5-2	ON	Heating temp. shift + 3°C	
	OFF	Normal	
SW5-3	ON	Invalid filter sign	
	OFF	Valid filter sign	

(h) Floor standing type (FDL)
Models All models

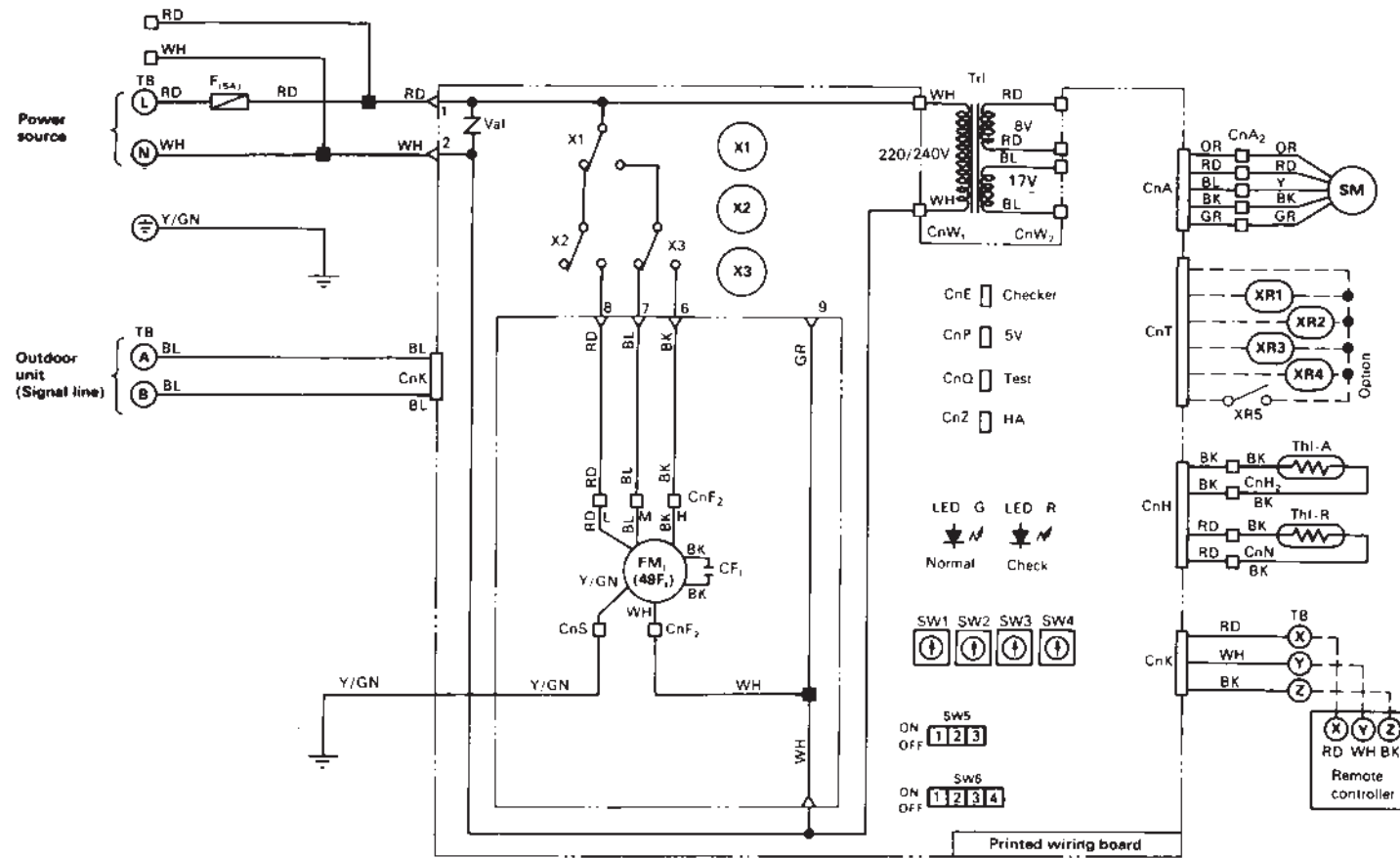

Color mark

Mark	Color	Mark	Color
BK	Black	RD	Red
BL	Blue	WH	White
GR	Gray	Y	Yellow
OR	Orange	Y/GN	Yellow/Green

Function of switches

Mark	Function	
SW5-1	ON	Input signal
	OFF	Reverse Invalid
SW5-2	ON	Heating temp. shift + 3°C
	OFF	Run Stop
SW5-3	ON	Invalid filter sign
	OFF	Valid filter sign

Meaning of marks

Mark	Parts name	Mark	Parts name	Mark	Parts name
FM ₁	Fan motor	SW3	Outdoor unit address ten's place	CnA-Z	Connector (□ mark)
CF ₁	Capacitor for FM ₁	SW4	Outdoor unit address unit's place	TB	Terminal block
49F ₁	Internal thermostat for FM ₁	SW6	Change of heat pume type	◁mark	Terminal (F)
SM	Stepping motor (For Exp.v)	Tr1	Transformer	■ mark	Connector
X1,2,3	Auxiliary relay (For FM ₁)	Val	Varistor	XR1	Operation indication (DC12)
Thi-A	Thermistor	LED-R	Indication lamp (Red)	XR2	Heating indication (DC12)
Thi-R	Thermistor	LED-G	Indication lamp (Green)	XR3	ON indication for CM (DC12)
SW1	Indoor unit address ten's place	F	Fuse	XR4	Check indication (DC12)
SW2	Indoor unit address unit's place			XR5	Distant operation

(2) Individual flow divide controller

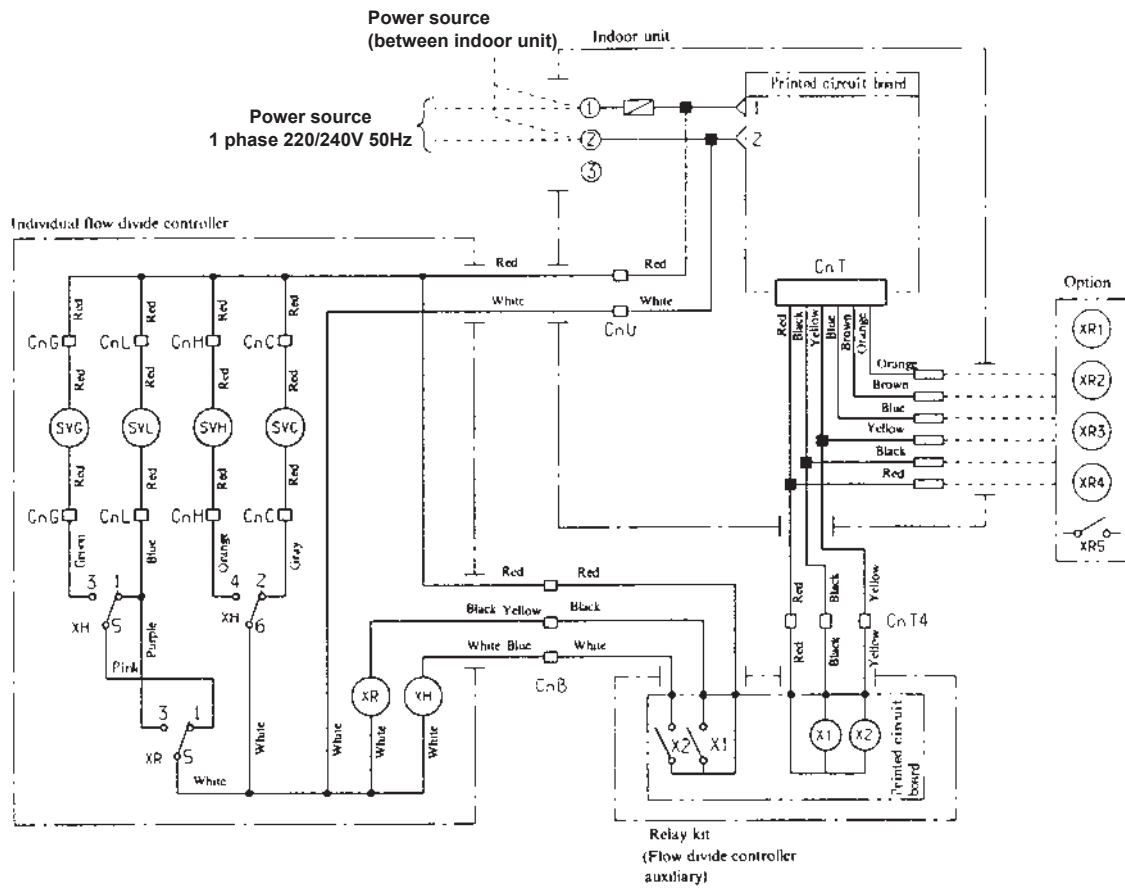

- Note (1) This illustration shows the circuit diagram for when 1 indoor unit is connected with a central flow divide controller and relay kit (flow divide controller accessory).
- (2) "....." denotes the local wiring.
- (3) The option shows when a remote start/stop and monitoring kit is connected.

• Meaning of marks

SVH	High-pressure gas solenoid valve
SVC	Low-pressure gas solenoid valve
SVL	Liquid solenoid valve
SVG	Bypass solenoid valve
XR, X1, XR1	Operation output
XH, X2, XR2	Heat output
XR3	Thermal ON output
XR4	Inspection output

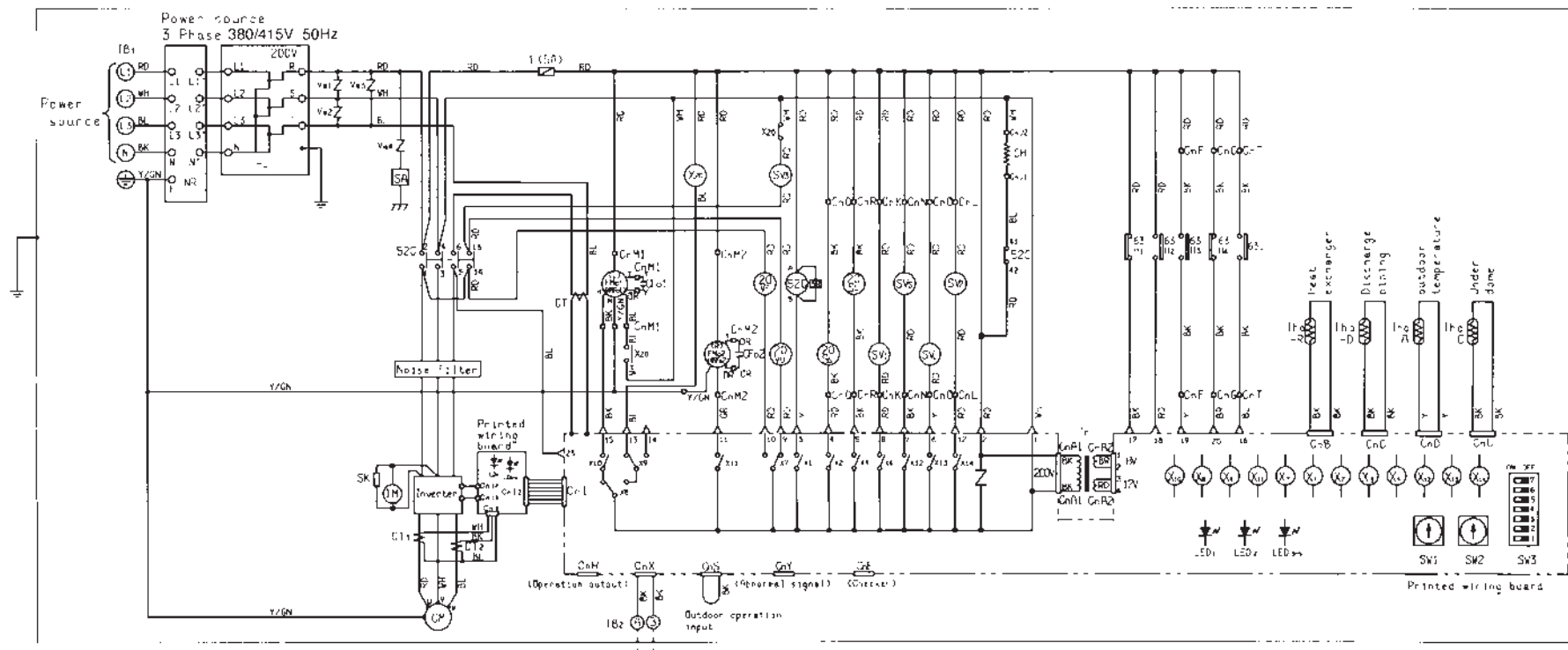

Notes (1) "....." denotes the local wiring.
(2) Ⓐ and Ⓑ of TB₂ are the signal wire terminal blocks (5V).

(3) Use 0.75 to 2mm² × 2 core wire for the indoor and outdoor connection signal wire.
(4) The signal wiring shall be separate from the power supply wiring.

Meaning of marks

Mark	Parts name	Mark	Parts name	Mark	Parts name
CM	Compressor motor	20S _L	4way valve (rear heat exchanger)	SK	Spark killer
FM _{1,2}	Fan motor (outdoor unit)	20V _F	Solenoid valve (full)	SA	Arrestor
IM	Motor for cooling inverter	20V _U	Solenoid valve (partial)	Tr	Transformer
52C	Magnetic contactor for CM	SV ₁	Solenoid valve (compressor cooling)	Va _{1,2,3,4}	Varistor
49F _{1,2}	Internal thermostat for FMo	SV ₂	Solenoid valve (excessive cooling heat exchanger by-pass)	TB _{1,2}	Terminal block
CH	Crankcase heater	SV ₃	Solenoid valve (discharge gas by-pass)	F	Fuse
CF _{1,2}	Capacitor for FMo	SV ₅	Solenoid valve (for front heat exchanger stoppage)	CnA-Y	Connector (□mark)
X ₁	Auxiliary relay (for 52C)	SV _L	Solenoid valve (rear heat exchanger stoppage)	SW ₁	Unit No.10 rank of outdoor unit
X ₂	Auxiliary relay (for 20SS)	63H ₁	High Pressure switch (for protection)	SW ₂	Unit No.1 rank of outdoor unit
X ₃	Auxiliary relay (for 20SL)	63H ₂	High Pressure switch (for control)	SW ₃₋₁	L.E.D. reset
X ₄	Auxiliary relay (for SV1)	63H ₃	High Pressure switch (high pressure control)	SW ₃₋₂	Defrost change
X ₇	Auxiliary relay (for 20VF, 20VU)	63H ₄	High Pressure switch (high pressure control)	SW ₃₋₃	Prevention of snow accumulation
X ₈₋₁₀	Auxiliary relay (for FMo1)	63L	Low Pressure switch (low pressure control)	LED ₁	Indication lamp (red)
X ₁₁	Auxiliary relay (for FMo2)	Tho-A	Thermistor (outdoor air temp)	LED ₂	Indication lamp (Green)
X ₁₂	Auxiliary relay (for SVS)	Tho-C	Thermistor (dome temp)	LED ₃₋₅	Indication lamp (Yellow)
X ₁₃	Auxiliary relay (for SVL)	Tho-D	Thermistor (discharge temp)	LD ₁₋₃	Indication lamp (Green)
X ₁₄	Auxiliary relay (for SV2)	Tho-R	Thermistor (outdoor H.X. temp)	LD _{2,4}	Indication lamp (red)
X ₂₀	Auxiliary relay (for SV3)	CT _{1,2}	Current sensor		
20S _S	4way valve (front heat exchanger)	NR	Noise killer		

Color mark

Mark	Color	Mark	Color
BK	Black	OR	Orange
BL	Blue	RD	Red
BR	Brown	WH	White
GN	Green	Y	Yellow
GR	Gray	Y/GN	Yellow/green

Function of switches

Mark	Function	
SW ₃₋₄	ON	Trial operation
	OFF	Regular operation
SW ₃₋₅	ON	Cooling trial operation
	OFF	Heating trial operation
SW ₃₋₆	ON	Compulsory operation
	OFF	Regular operation
SW ₃₋₇	ON	Test mode
	OFF	Regular operation

Refrigerant piping [1/3] [2/3] [3/3]

3. APPLICATION DATA

3.1 Refrigerant Piping

■ Refrigerant piping size selection table

	Outdoor unit connection pipe		Branch line			Indoor unit connection pipe			Flow divide controller connection pipe	
			Downstream indoor unit capacity total ⁽¹⁾							
	FDC2001 type	FDC2501 type	160 or more	160 or less 90 or more	90 or less	201, 251 321, 401 type	501,631,801 type	1001, 1251 type	models Indoor side	Outdoor side
Liquid piping	φ12.7 × 1.0 mm	φ12.7 × 1.0 mm	φ12.7 × 1.0 mm	φ9.52 × 0.8 mm	φ9.52 × 0.8 mm	φ6.35 × 0.8 mm	φ9.52 × 0.8 mm	φ9.52 × 0.8 mm	φ9.52 × 0.8 mm	φ9.52 × 0.8 mm
Intake gas piping	φ25.4 × 1.2 mm	φ28.58 × 1.4 mm	φ25.4 × 1.2 mm	φ19.05 × 1.0 mm	φ15.88 × 1.0 mm	φ12.7 × 1.0 mm	φ15.88 × 1.0 mm	φ19.05 × 1.0 mm	φ15.88 × 1.0 mm	φ15.88 × 1.0 mm
Discharge gas piping	φ19.05 × 1.0 mm	φ19.05 × 1.0 mm	φ19.05 × 1.0 mm	φ15.88 × 1.0 mm	φ12.7 × 1.0 mm					φ12.7 × 1.0 mm



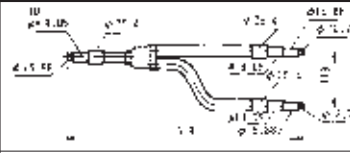
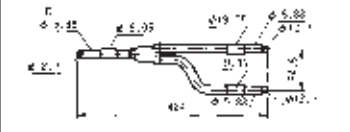
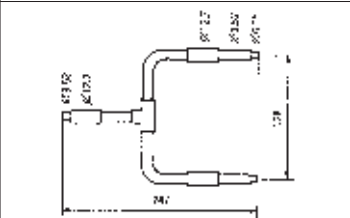
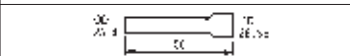

Note (1) This shows the total capacity of the indoor units connected after indicated branch pipe.
 (2) 1 flow divider pipe set is required for each division.

Branch pipe set part shapes

Symbol	Name	Part shape	Quantity	Remarks
①	Branch pipe		1	Intake gas piping
②			1	Discharge gas piping
③			1	Liquid piping
Ⓐ	Reducer		1	Intake gas piping (FDC2501HKXRE2)

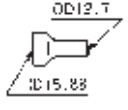
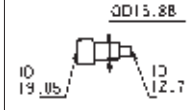
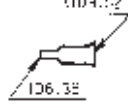
Note (1) Each flow divider pipe is surrounded with insulation.
 (2) Each pipe is cut off in the middle of the diameter that is used in that locality.

Shapes of individual flow divide controller accessories

Name	Reducer			Strainer coupline	In Sulation	Relay kit
Application	For outdoor discharge gas piping	For outdoor intake and indoor gas piping	For outdoor and indoor liquid piping	For outdoor discharge gas piping	For pipe cover	For controller
Quantity	1	2	2	1	Piping connection	Number of divisions
Shape						
Code	Ⓐ	Ⓑ	Ⓒ	—	—	—

Example of piping

Outdoor unit: FDC2501HKXRE2

Indoor unit: Combination of 6 units

(Individual flow divide controller: HPHD01R-E × 6 sets
Branch pipe set: DIS-1KXR3-E × 5 sets)

[Total capacity: 312 (34800w)]

Symbols

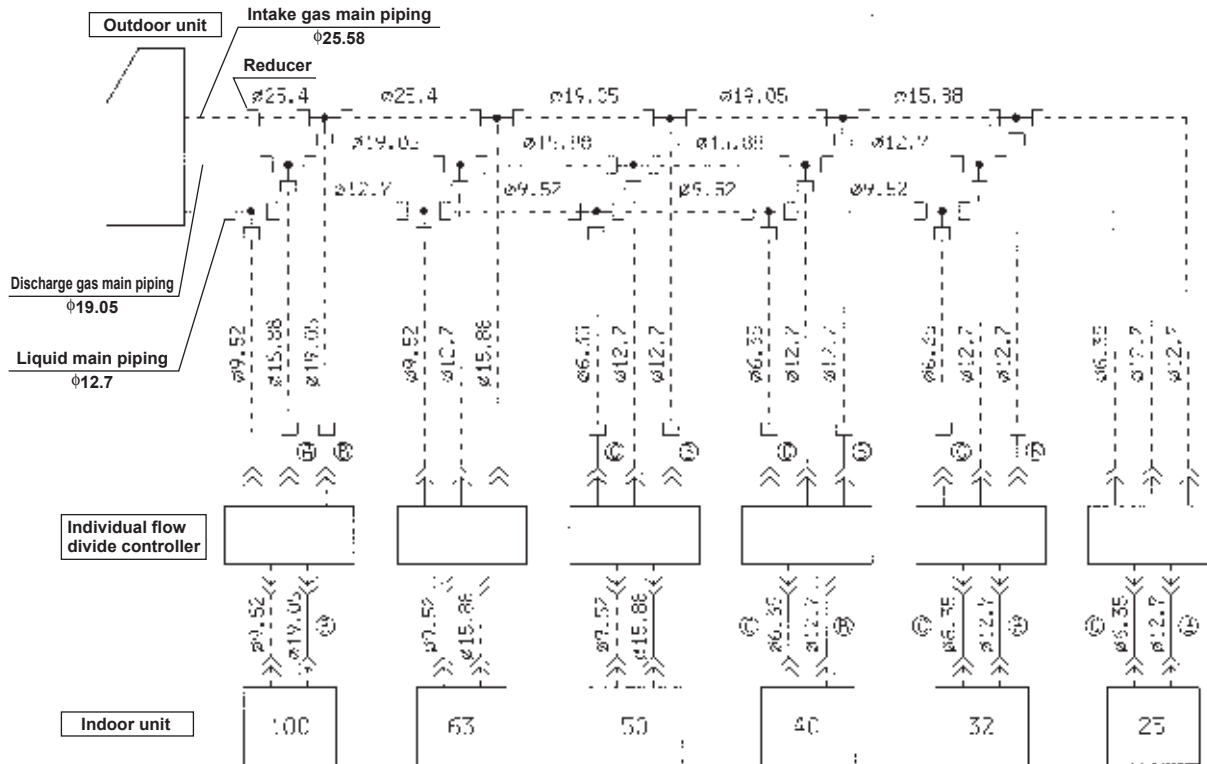
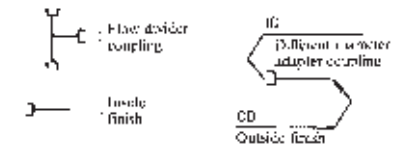

Piping connection instructions (for the above example)

Process the included reducer as illustrated below.

Use the flare nuts included with the individual flow divide controller.

- When the indoor unit capacity is 90 or more

A type

Use reducer (A) and process the φ12.7 portion into a flare.
(OD12.7 → ID15.88)

B type

Cut off reducer (B) using a pipe cutter as shown in the illustration and make a flare.
(OD15.88 → ID19.88)

Reducer (B) (accessory)

- When the indoor unit capacity is 50 or less

B type

Cut off reducer (B) using a pipe cutter as shown in the illustration and make a flare.
(OD15.88 → ID12.7)

Reducer (B) (accessory)

When the outdoor unit are installed at a higher level than the individual flow divide controller and a vertical flow divider is required for the piping connections of 2 or more individual flow divide controllers for 1 module, use the "flow divider pipe set" for vertical divides.

● Flow divider pipe set for vertical divides Part No. DIS-V1KXR3-E

Shapes of accessory parts for brunch pipe set for vertical divides

Classification	Symbol	Branch pipe	Classification	Symbol	Branch pipe
Intake gas piping	①		Intake gas piping	-	
Discharge gas piping	②		Intake gas piping	-	<p>Reference 1: Be sure to install the vertical flow divider coupling (both) for gas and liquid as "vertical divide" as illustrated below.</p>
Liquid piping	③				

Note (1) Insulation is provided to all flow divider pipes.
 (2) Cut off the flow divider pipes in the center to match the diameter of the piping used on site.

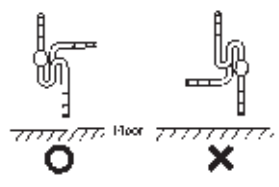

(Example)

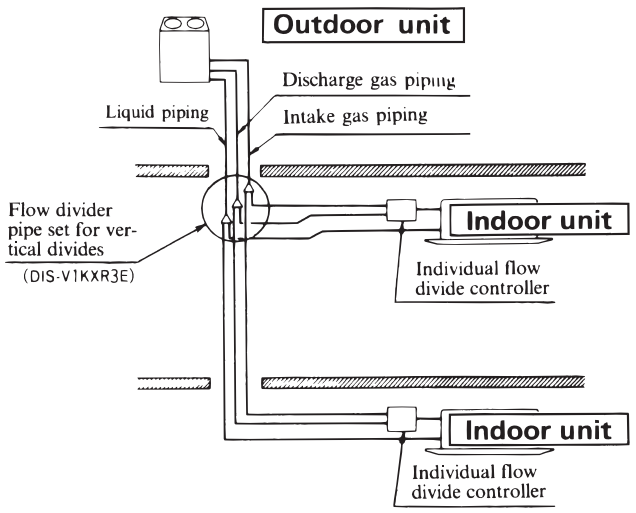

(1)Precaution in electric wiring

(2)Wiring system Diagram [1/2] [2/2]

(3)Indoor and outdoor signal wiring

(4)Remote controller wiring

3.2 Electric wiring

(1) Precaution in electric wiring.

(a) Use separate power supplies for the outdoor and indoor units respectively (Standard specification)

(b) Signal wiring (for indoor and outdoor units)

- Double-core cable with a diameter 0.75 to 2 mm² should be used for the signal wires.
- **Never make the indoor and outdoor connecting signal line use “co-axial cable” or “strand” with the power wiring for indoor and outdoor unit and other power line.**

(Never use a multiconductor wire together with power line. It may cause erroneous operation.)

- Do not connect high voltage wires 220/240 V or 380/415 V to signal wires. as these wires are DC 5V. Signal wires should be connected so that the terminal Nos. conform with each other for between outdoor and between indoor units. However, they will work properly if different polarities are connected.

(Connect (A) and (A), (B) and (B).)

- **Do not strand or run the remote control cord with power line, electric line, etc.**

- The total length of the signal wires Should be 1000m or less.

- **Recommended signal wire list**

No.	Name	Symbol
1	Vinyl cabtire round cord	VCTF double-core 0.75 to 2 mm ²
2	Vinyl cabtire round cable	VCT double-core 0.75 to 2 mm ²
3	Control vinyl insulated, vinyl sheathed cable	CVV double-core 0.75 to 2 mm ²
4	Shielding wire	MVVS double-core 0.75 to 2 mm ²

When No. 4 shielding wire is used, always ground the single wire side of the shielding wire . In addition, using the shielding wire is helpful to prevent the incorrect connection between 5V DC and 220/240V or 380/415V AC because the discrimination from the power supply wire is clear.

(2) Wiring system Diagram

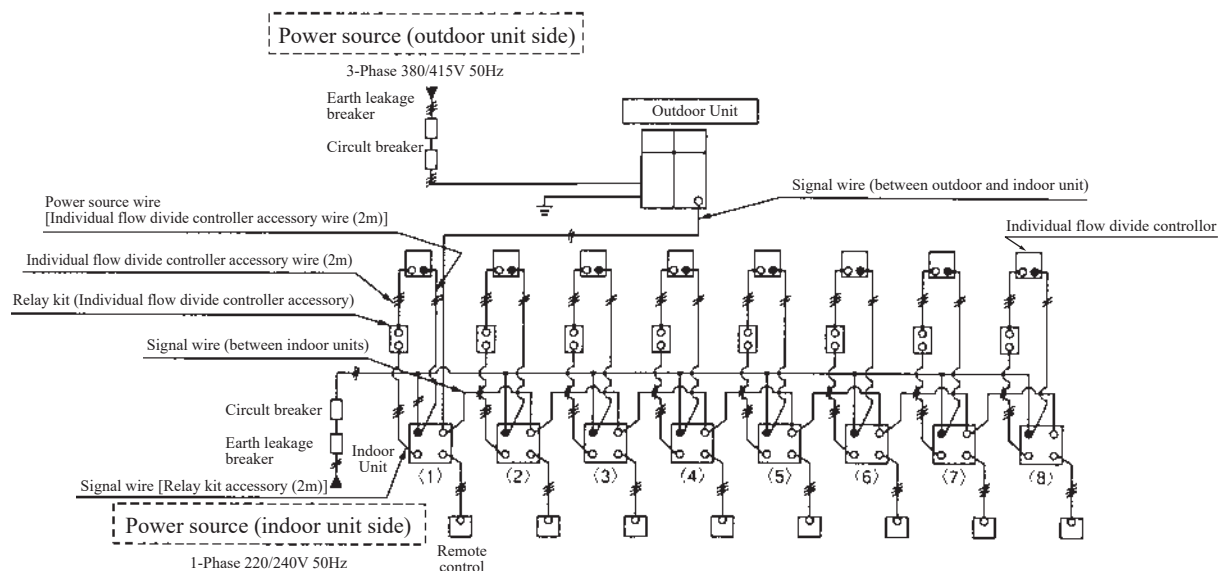

Outdoor/Indoor units connection procedures

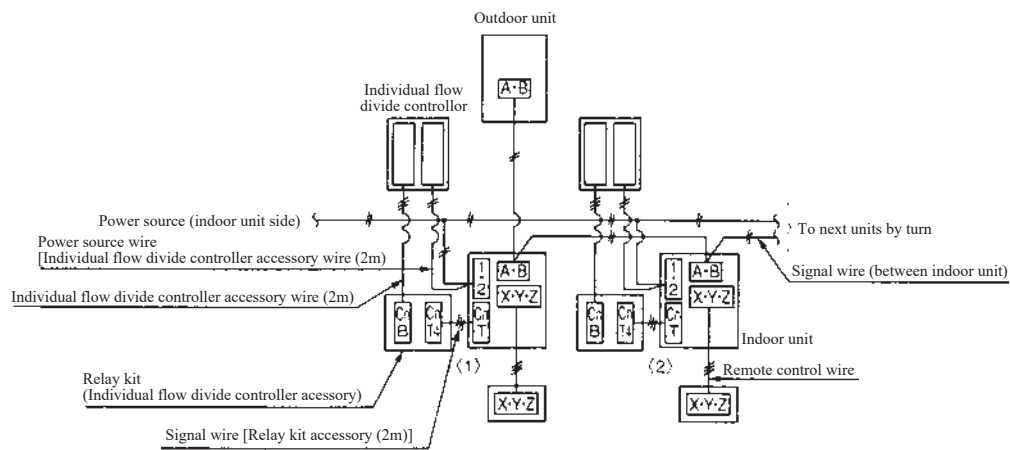

Signal wire

- Do not connect high voltage wire 380/415V to signal wires, as these wires are DC 5V. Signal wires should be connected so that the terminal Nos. conform with each other for between outdoor and between indoor units. However, they will work properly if different polarities are connected. (Connect (A) and (A), (B) and (B).)

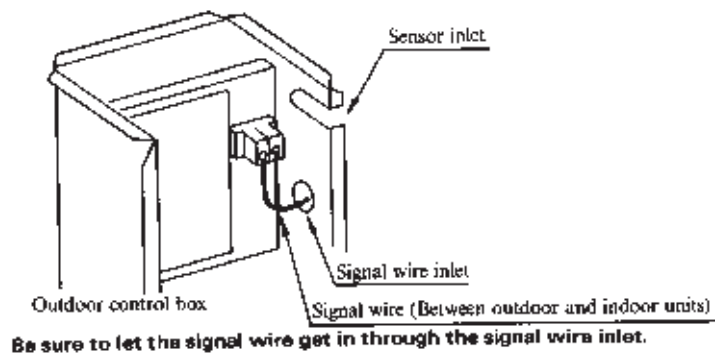

(3) Indoor and outdoor signal wiring

(a) If only one Outdoor unit is used

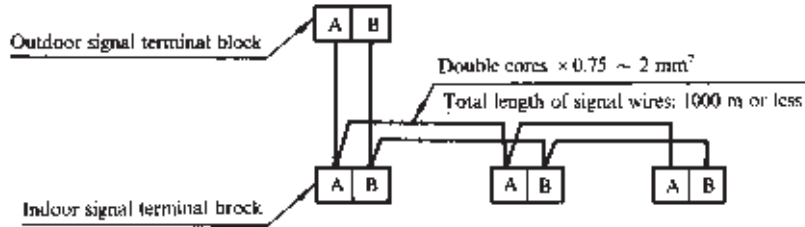

Notes (1) The indoor and outdoor signal wiring are without polarity



Either of the above wiring is correct.

(2) For connection to the terminal block, use as M3.5 (5/32) round eye-let terminal is shown below.



(b) If plural outdoor units are used

1) A maximum of 48 indoor units can be connected by using the crossover wiring method, with 2 wires for each side of the outdoor and indoor units.

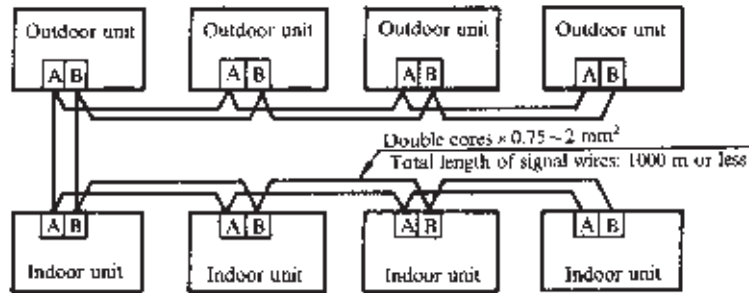

2) Indoor/outdoor wiring method for multiple floors.

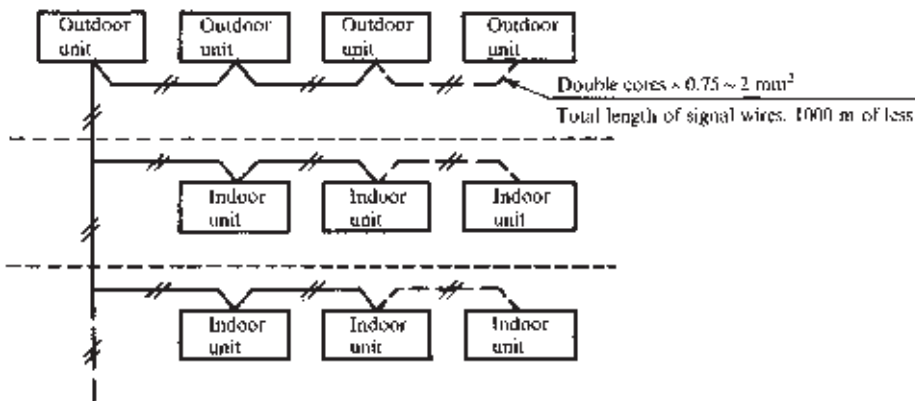

3) Loop wiring is inhibited

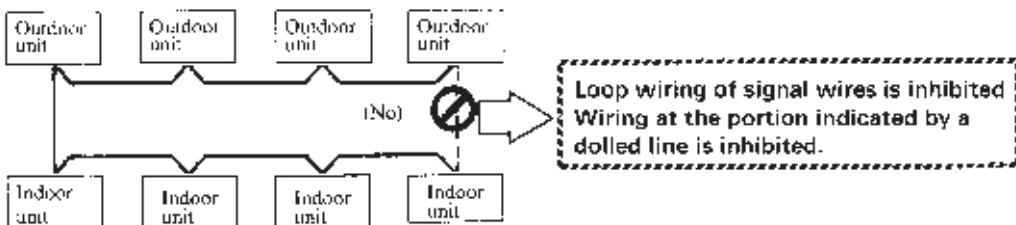

(4) Remote controller wiring

(a) Wiring for controlling only one indoor unit.

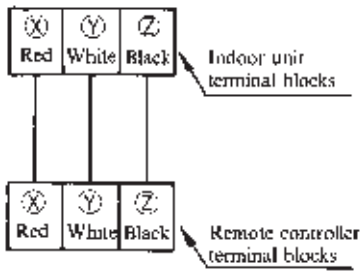

Note (1) Cables for the remote controller have polarity. Be sure to connect terminal blocks with the same numbers. If mis wiring occurs, E1 is displayed and disables the unit operating.

(b) When controlling plural units.

1) Use the same procedure shown in the drawing above for the wiring of the power supply, both indoor and outdoor units and remote controller

When the wiring length for the remote controller exceeds 100 m, use the wiring procedure shown in the drawing below.

2) Connect each of the indoor units for group controlling (3 cables)

a) Connect the cables to the terminal blocks of X, Y, and Z for the indoor unit remote controller. Since the cables have polarity, be sure to connect them to terminal blocks with the same numbers.

b) Use cables of more than 0.5 mm² (Flexible and easily moved)

c) The total length of cables for crossover connection and the remote controller should be less than 600 m.

Allowable rang of wire thickness and length

Standard	Within 0.3mm ² × Within 100m
	0.5mm ² × Within 200m
	0.75mm ² × Within 300m
	1.25mm ² × Within 400m
	2mm ² × Within 600m

3) When there is more than one outdoor unit, they can be controlled by one Remote controller.

4) One remote controller is capable of controlling up to 16 units in group.

Notes (1) Use shielded cables, when wiring in parallel with cables for other power supply or when there is a possibility of being affected by outer noise such as noise from a high-frequency unit.

