



**LG Electronics Inc.**

**LN-PD-01**

**Ducted Split-System  
Cooling**

# Product Data

## LN-Series

3 ton, 4 ton, 5 ton

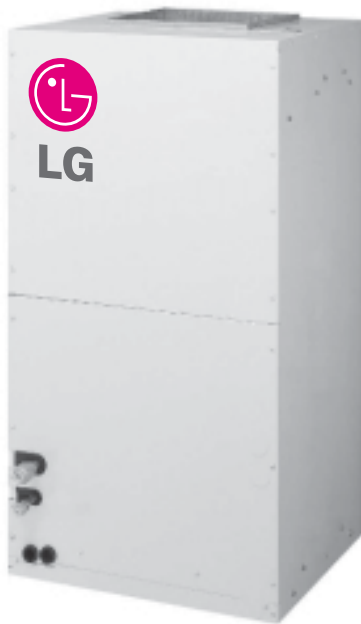

**Air Handling Unit**



**Condensing Unit**

**MODELS: LN-0320CC  
LN-0420CC  
LN-0520CC**

**File Tab Position: 1**

P/No.: 3828A30041M

**Rev. No.: 1**

April, 2001  
Printed in Korea



# Model Number Nomenclature

## Table of contents

Model Number Nomenclature .....	2
Features .....	3
General Data .....	4
Performance Data .....	5
Electrical Requirements .....	11
Wiring Diagram .....	12
Dimensions .....	13
Mechanical Specifications .....	14
Specification of Components .....	15

## Model Number Nomenclature

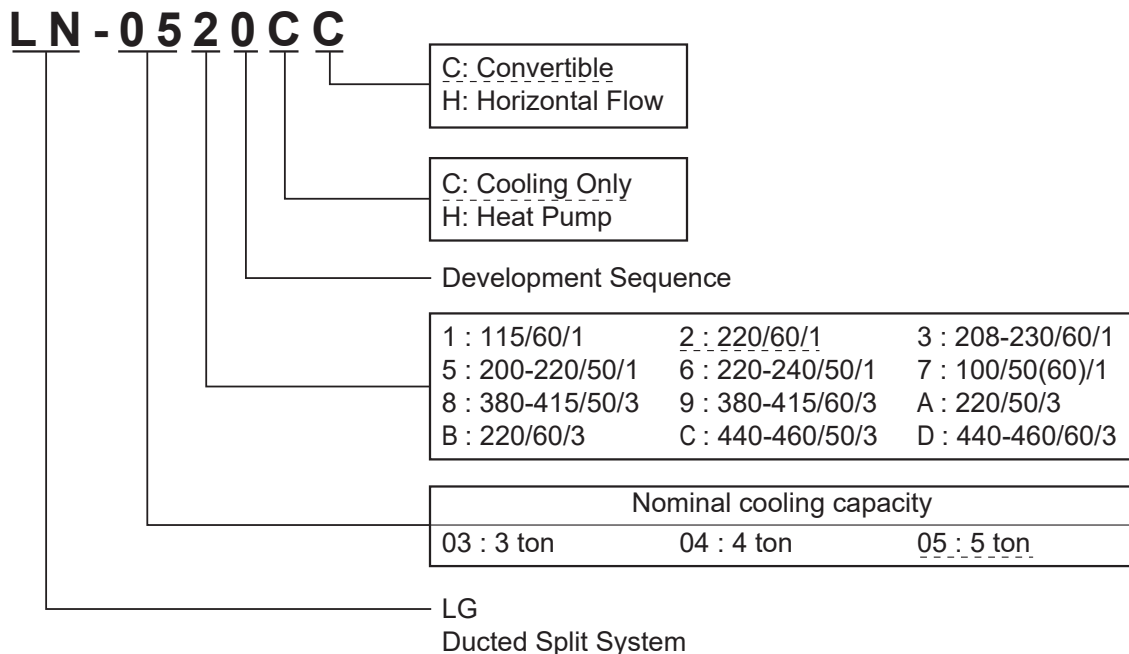

# Features

---

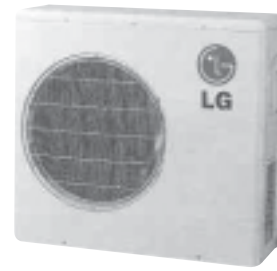
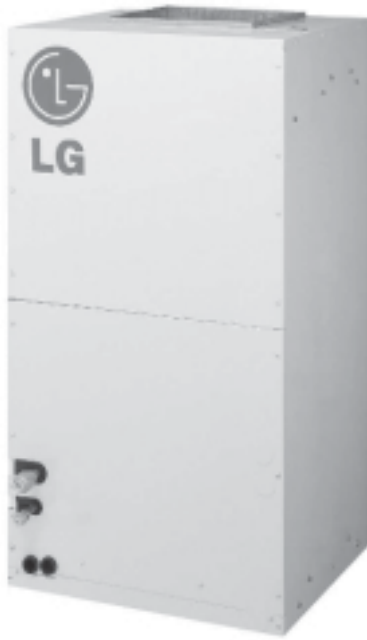

## Air Handlers

- 4 way Convertibility-horizontal(Left & right), up-flow, down-flow.
- Plastic drain Pan
- High efficient Evaporator Coil
- Galvanized Steel with painting
- Washable and Anti-fungus Filter
- Direct drive Motor
- Multi-speed blower
- Insulated cabinet
- Time delay PCB
- 220V primary & 24V secondary transformer.
- Defrost sensor

## Condensing Units

- Hi-Reliability Compressor
- Internal pressure relief valve provides high pressure protection for compressor
- Compressor internal overload protection
- Vertical air-discharge.(4 ton and 5 ton)
- Side air-discharge (3 ton)
- Outside pressure taps for refrigerant system check
- Factory supplied charge of R-22
- 7ø Heat exchanger



# General Data

## Table-1

Nominal ton		(Ton)	3	4	5	
Models			LN-0320CC	LN-0420CC	LN-0520CC	
<b>Capacity</b>	ARI Net Cooling Capacity		(BTU/hr)	35,000	48,000	58,000
			(Kcal/h)	8,820	12,097	14,617
<b>Electrical Data</b>	Voltage		(V,PH)	220V,1PH	220V,1PH	220V,1PH
	M.C.A(with standard motor)	Cooling	(Amps)	23.8	28.8	38.1
	Power Input	Cooling	(Watt)	4,000	5,000	6,600
<b>Performance</b>	Air Circulation	Nominal CFM	CFM	1,200	1,600	2,000
	EER	Cooling	(BTU/hr.W)	8.75	9.6	8.5
	Sound Rating	Cooling	bel	8.0	8.0	8.0
<b>Features</b>	Filter type			Washable & antifungus	Washable & antifungus	Washable & antifungus
<b>Compressor</b>	Type			Reciprocating	Reciprocating	Reciprocating
	Quantity			1	1	1
<b>Outdoor Coil</b>	Type			High efficiency	High efficiency	High efficiency
	Tube size(O.D)	(inch)		0.276	0.276	0.276
		(mm)		7.0	7.0	7.0
	Row/FPI			2R/18FPI	2R/18FPI	2R/18FPI
	Lengh	(inch)		32.2	48.8	53.4
		(mm)		818.6	1240.4	1357.4
	Face area	(sq.ft)		6.67	11.22	12.27
(m <sup>2</sup> )			0.62	1.04	1.14	
<b>Indoor Coil</b>	Type			High efficiency	High efficiency	High efficiency
	Tube size(O.D)	(inch)		0.375	0.375	0.375
		(mm)		9.52	9.52	9.52
	Row/FPI			2R/18FPI	2R/18FPI	3R/16FPI
	Lengh	(inch)		15.16	15.75	15.75
		(mm)		385	400	400
	Face area	(sq.ft)		3.55	4.63	4.63
(m <sup>2</sup> )			0.33	0.43	0.43	
<b>Outdoor Fan</b>	Type			Propeller	Propeller	Propeller
	No. Used/Diameter(in.)			1EA/18.1"	1EA/22.7"	1EA/22.7"
	Drive Type			Direct	Direct	Direct
	CFM			2,048	3,743	3,743
	No. Motor/Motor output(Hp)			1/0.12	1/0.3	1/0.3
	Motor RPM			930	970	970
<b>Indoor Fan</b>	Type			Centrifugal Blower Fan		
	No. Used			1EA	1EA	1EA
	Diameter/Width(in.)			7.9"/7.2"	7.9"/11"	7.9"/11"
	Drive Type/Motor Step			Direct/3	Direct/3	Direct/3
	No.motors			1EA	1EA	1EA
	Motor output(standard/oversized)			0.47hp/N.A	0.47hp/N.A	0.73hp/N.A
	Motor rpm(Standard/oversized)			995/N.A	995/N.A	1,080/N.A
	<b>Drain Connection Size(in.)</b>			3/4"	3/4"	3/4"
<b>Refrigerant</b>	Refrigerant Charge		(Lbs)	3.7	6.8	8.3
<b>Dimensions</b>	Indoor unit (WxHxD)	(inch)		18.5*18.9*39.9	23.6*19.7*44.7	23.6*19.7*44.7
		(mm)		470*480*1014	600*500*1135	600*500*1135
	Outdoor unit (WxHxD)	(inch)		34.3*31.5*12.6	28.4*33.7*27.2	28.4*33.7*27.2
		(mm)		870*800*320	722*855*691	722*855*691
<b>Weight</b>	Indoor unit	(kg)		53	59	63
		(lbs)		117	130	139
	Outdoor unit	(kg)		65	105	110
		(lbs)		143	214	243

- 1) Test Condition of ARI Rated Cooling Capacity :  
 Ambient:95°F , Air entering temperature : 80°F DB and 67°F WB  
 2) ARI standard  
 210/240 or 360 for EER  
 270 for Sound

# Performance data

## Performance data

**Table-2** Net Cooling Capacity(MBH) 3Ton LN-0320CC

Outdoor	DB	85						95						105			
Indoor	WB	61		67		73		61		67		73		61		67	
CFM	DB	TGC	SHC	TGC	SHC	TGC	SHC	TGC	SHC	TGC	SHC	TGC	SHC	TGC	SHC	TGC	
960	75	30	23.4	33.2	17.7	35.7	7.8	28.9	23.9	32	18.1	34.4	8	27.4	22.8	30.3	
	80	31.3	26.9	33.8	22.2	35.7	14.5	30.2	27.4	32.6	22.6	34.4	14.8	28.6	26.2	30.8	
	85	32.5	29.5	34.3	26.7	35.6	20.1	31.3	30	33.1	27.3	34.3	20.5	29.7	28.7	31.3	
	90	33.6	31	34.6	29.7	35.4	24.5	32.4	31.6	33.4	30.3	34.1	25	30.6	30.2	31.6	
1080	75	31.6	25.1	34.9	19	37.5	8.4	30.4	25.6	33.7	19.4	36.2	8.6	28.8	24.4	31.8	
	80	32.9	28.8	35.5	23.8	37.5	15.6	31.8	29.4	34.3	24.3	36.2	15.9	30.1	28.1	32.4	
	85	34.2	31.6	36	28.7	37.4	21.6	33	32.2	34.8	29.2	36.1	22	31.2	30.8	32.9	
	90	35.3	33.3	36.4	31.9	37.2	26.3	34	33.9	35.1	32.5	35.9	26.8	32.2	32.2	33.2	
1200	75	32.2	27.2	35.6	20.6	38.3	9.1	31.1	27.7	34.4	21	37	9.3	29.4	26.4	32.5	
	80	33.6	31.2	36.3	25.8	38.3	16.9	32.4	31.8	35	26.3	37	17.2	30.7	30.4	33.1	
	85	34.9	34.2	36.8	31	38.2	23.3	33.7	33.7	35.5	31.6	36.9	23.8	31.9	31.9	33.6	
	90	36	36	37.2	34.5	38	28.4	34.8	34.8	35.9	35.1	36.7	29	32.9	32.9	34	
1320	75	33	27.2	36.4	20.6	39.2	9.1	31.8	27.7	35.1	21	37.8	9.3	30.1	26.5	33.3	
	80	34.4	31.3	37.1	25.8	39.2	16.9	33.2	31.9	35.8	26.3	37.8	17.2	31.4	30.4	33.9	
	85	35.7	34.3	37.6	31.1	39.1	23.4	34.4	34.4	36.3	31.7	37.7	23.8	32.6	32.6	34.3	
	90	36.8	36.1	38	34.5	38.8	28.5	35.5	35.5	36.7	35.2	37.5	29	33.6	33.6	34.7	
1440	75	33.2	27.9	36.7	21.2	39.5	9.3	32	28.5	35.4	21.6	38.1	9.5	30.3	27.2	33.5	
	80	34.6	32.1	37.4	26.5	39.5	17.4	33.4	32.1	36.1	27	38.1	17.7	31.6	31.2	34.1	
	85	36	35.2	37.9	31.9	39.4	24	34.7	34.7	36.6	32.5	38	24.5	32.8	32.8	34.6	
	90	37.1	37	38.3	35.4	39.1	29.2	35.8	35.8	37	36.1	37.8	29.8	33.9	33.9	35	
Outdoor	DB	105				115						125					
Indoor	WB	67		73		61		67		73		61		67		73	
CFM	DB	SHC	TGC	SHC	TGC	SHC	TGC	SHC	TGC	SHC	TGC	SHC	TGC	SHC	TGC	SHC	
960	75	17.3	32.6	7.6	25.6	22	28.3	16.6	30.4	7.3	23.5	20.8	26	15.7	27.9	6.9	
	80	21.6	32.6	14.2	26.7	25.2	28.8	20.8	30.4	13.6	24.5	23.8	26.4	19.7	27.9	12.9	
	85	26	32.5	19.6	27.7	27.7	29.2	25.1	30.4	18.9	25.4	25.4	26.8	23.7	27.8	17.8	
	90	28.9	32.3	23.8	28.6	28.6	29.5	27.9	30.2	23	26.3	26.3	27.1	26.4	27.7	21.7	
1080	75	18.5	34.2	8.2	26.9	23.6	29.8	17.8	32	7.9	24.7	22.3	27.3	16.9	29.4	7.4	
	80	23.2	34.3	15.2	28.1	27.1	30.3	22.3	32	14.6	25.8	25.6	27.8	21.1	29.4	13.8	
	85	27.9	34.2	21	29.1	29.1	30.7	26.9	31.9	20.2	26.7	26.7	28.2	25.4	29.3	19.1	
	90	31	34	25.6	30.1	30.1	31.1	29.9	31.7	24.6	27.6	27.6	28.5	28.3	29.1	23.3	
1200	75	20	35	8.8	27.5	25.5	30.4	19.3	32.7	8.5	25.2	24.1	27.9	18.2	30	8.1	
	80	25.1	35	16.4	28.7	28.7	30.9	24.2	32.7	15.8	26.3	26.3	28.4	22.8	30	15	
	85	30.2	34.9	22.7	29.8	29.8	31.4	29.1	32.6	22.6	27.3	27.3	28.8	27.5	29.9	20.7	
	90	33.6	34.7	27.7	30.7	30.7	31.7	31.7	32.4	27.5	28.2	28.2	29.1	29.1	29.7	25.2	
1320	75	20.1	35.8	8.9	28.1	25.5	31.1	19.3	33.4	8.5	25.8	24.1	28.5	18.3	30.6	8.1	
	80	25.1	35.8	16.5	29.3	29.3	31.6	24.2	33.4	15.9	26.9	26.9	29	22.9	30.7	15	
	85	30.3	35.7	22.8	30.4	30.4	32.1	29.2	33.3	21.9	27.9	27.9	29.4	27.6	30.6	20.7	
	90	33.6	35.4	27.7	31.4	31.4	32.4	32.4	33.1	26.7	28.8	28.8	29.8	29.8	30.4	25.3	
1440	75	20.6	36	9.1	28.3	26.2	31.3	19.9	33.7	8.8	26	24.8	28.7	18.8	30.9	8.3	
	80	25.8	36	16.9	29.6	29.6	31.9	24.9	33.7	16.3	27.1	27.1	29.2	23.5	30.9	15.4	
	85	31.1	35.9	23.4	30.7	30.7	32.3	29.9	33.6	22.5	28.1	28.1	29.7	28.3	30.8	21.3	
	90	34.5	35.7	28.5	31.7	31.7	32.7	32.7	33.4	27.4	29.1	29.1	30	30	30.6	25.9	

**Notes:**

1. All capacities are net; They account for the effects of the indoor-fan motor power and heat.
2. TOT = Total Cooling Capacity (net)
3. SEN = Sensible Heat Capacity (net)
4. Unit : MBH = 1,000 Btu/h



# Performance data

## Performance data

**Table-3**

**Net Cooling Capacity(MBH) 4Ton LN-0420CC**

Outdoor	DB	85						95						105			
Indoor	WB	61		67		73		61		67		73		61	67		
CFM	DB	TGC	SHC	TGC	SHC	TGC	SHC	TGC	SHC	TGC	SHC	TGC	SHC	TGC	SHC	TGC	
1280	75	41.2	32.1	45.5	24.3	48.9	10.7	39.7	32.7	43.9	24.8	47.2	10.9	37.6	31.3	41.5	
	80	42.9	36.9	46.3	30.5	48.9	19.9	41.4	37.6	44.7	31	47.2	20.3	39.2	35.9	42.3	
	85	44.6	40.4	47	36.7	48.8	27.6	43	41.2	45.3	37.4	47.1	28.1	40.7	39.4	42.9	
	90	46	42.6	47.5	40.7	48.5	33.6	44.4	43.4	45.8	41.5	46.8	34.2	42	41.4	43.3	
1440	75	43.3	34.4	47.9	26.1	51.4	11.5	41.8	35.1	46.2	26.6	49.6	11.7	39.5	33.5	43.7	
	80	45.2	39.5	48.7	32.7	51.5	21.4	43.6	40.3	47	33.3	49.7	21.8	41.2	38.5	44.5	
	85	46.9	43.3	49.4	39.3	51.3	29.6	45.2	44.2	47.7	40.1	49.5	30.1	42.8	42.2	45.1	
	90	48.4	45.6	49.9	43.7	51	36	46.7	46.5	48.2	44.5	49.2	36.7	44.2	44.2	45.6	
1600	75	44.2	37.2	48.9	28.2	52.5	12.5	42.7	38	47.2	28.7	50.7	12.7	40.4	36.3	44.6	
	80	46.1	42.8	49.8	35.3	52.6	23.1	44.5	43.6	48	36	50.7	23.6	42.1	41.6	45.4	
	85	47.9	46.9	50.5	42.5	52.4	32	46.2	46.2	48.7	43.4	50.6	32.6	43.7	43.7	46.1	
	90	49.4	49.4	51	47.3	52.1	39	47.7	47.7	49.2	48.2	50.3	39.7	45.1	45.1	46.6	
1760	75	45.2	37.3	50	28.3	53.7	12.5	43.6	38	48.2	28.8	51.8	12.7	41.2	36.3	45.6	
	80	47.1	42.9	50.9	35.4	53.7	23.2	45.5	43.7	49.1	36.1	51.8	23.6	43	41.7	46.4	
	85	48.9	47	51.6	42.6	53.6	32.1	47.2	47.2	49.8	43.4	51.7	32.7	44.7	44.7	47.1	
	90	50.5	49.5	52.1	47.4	53.3	39	48.8	48.8	50.3	48.3	51.4	39.8	46.1	46.1	47.6	
1920	75	45.5	38.3	50.4	29	54.1	12.8	43.9	39	48.6	29.6	52.2	13.1	41.6	37.3	46	
	80	47.5	44	51.3	36.3	54.2	23.8	45.8	44	49.4	37	52.2	24.3	43.4	42.8	46.8	
	85	49.3	48.2	52	43.8	54	32.9	47.6	47.6	50.2	44.6	52.1	33.5	45	45	47.5	
	90	50.9	50.8	52.6	48.6	53.7	40.1	49.1	49.1	50.7	49.5	51.8	40.8	46.5	46.5	48	
Outdoor	DB	105				115						125					
Indoor	WB	67		73		61		67		73		61		67		73	
CFM	DB	SHC	TGC	SHC	TGC	SHC	TGC	SHC	TGC	SHC	TGC	SHC	TGC	SHC	TGC	SHC	
1280	75	23.7	44.6	10.5	35.1	30.1	38.8	22.8	41.7	10.1	32.2	28.5	35.6	21.6	38.3	9.5	
	80	29.7	44.7	19.4	36.6	34.6	39.5	28.6	41.7	18.7	33.6	32.7	36.2	27	38.3	17.7	
	85	35.7	44.5	26.9	38	37.9	40.1	34.4	41.6	25.9	34.9	34.9	36.8	32.5	38.2	24.5	
	90	39.7	44.3	32.7	39.3	39.3	40.5	38.2	41.4	31.5	36	36	37.2	36.1	38	29.8	
1440	75	25.4	47	11.2	36.9	32.3	40.8	24.5	43.9	10.8	33.9	30.5	37.4	23.1	40.3	10.2	
	80	31.8	47	20.8	38.5	37.1	41.6	30.6	43.9	20.1	35.3	35.1	38.1	29	40.3	19	
	85	38.3	46.8	28.8	40	40	42.2	36.9	43.8	27.8	36.7	36.7	38.7	34.9	40.2	26.2	
	90	42.5	46.6	35.1	41.3	41.3	42.6	41	43.5	33.8	37.9	37.9	39.1	38.8	39.9	31.9	
1600	75	27.5	48	12.1	37.7	35	41.7	26.5	44.8	11.7	34.6	33	38.2	25	41.1	11	
	80	34.4	48	22.5	39.3	39.3	42.4	33.1	44.8	21.7	36.1	36.1	38.9	31.3	41.1	20.5	
	85	41.4	47.9	31.2	40.8	40.8	43.1	39.9	44.7	30.9	37.5	37.5	39.5	37.7	41	28.4	
	90	46	47.6	37.9	42.2	42.2	43.5	43.5	44.4	37.7	38.7	38.7	39.9	39.9	40.8	34.6	
1760	75	27.5	49	12.1	38.5	35	42.6	26.5	45.8	11.7	35.4	33.1	39.1	25.1	42	11.1	
	80	34.5	49.1	22.6	40.2	40.2	43.4	33.2	45.8	21.8	36.9	36.9	39.8	31.4	42.1	20.6	
	85	41.5	48.9	31.2	41.7	41.7	44	40	45.7	30.1	38.3	38.3	40.4	37.8	41.9	28.4	
	90	46.1	48.6	38	43.1	43.1	44.5	44.4	45.4	36.6	39.5	39.5	40.8	40.8	41.7	34.6	
1920	75	28.2	49.4	12.5	38.8	36	43	27.2	46.2	12	35.6	34	39.4	25.7	42.4	11.4	
	80	35.4	49.4	23.2	40.5	40.5	43.7	34.1	46.2	22.3	37.2	37.2	40.1	32.2	42.4	21.1	
	85	42.6	49.3	32	42.1	42.1	44.4	41.1	46.1	30.9	38.6	38.6	40.7	38.8	42.3	29.2	
	90	47.3	49	39	43.4	43.4	44.8	44.8	45.8	37.6	39.9	39.9	41.1	41.1	42	35.5	

**Notes:**

1. All capacities are net; They account for the effects of the indoor-fan motor power and heat.
2. TOT = Total Cooling Capacity (net)
3. SEN = Sensible Heat Capacity (net)
4. Unit : MBH = 1,000 Btu/h

# Performance data

## Performance data

**Table-4**

**Net Cooling Capacity(MBH) 5Ton LN-0520CC**

Outdoor	DB	85						95						105			
Indoor	WB	61		67		73		61		67		73		61		67	
CFM	DB	TGC	SHC	TGC	SHC	TGC	SHC	TGC	SHC	TGC	SHC	TGC	SHC	TGC	SHC	TGC	
1600	75	49.7	38.8	55	29.4	59.1	13	48	39.5	53	29.9	57	13.2	45.4	37.8	50.2	
	80	51.9	44.6	56	36.8	59.1	24.1	50	45.4	54	37.5	57	24.6	47.4	43.4	51.1	
	85	53.8	48.8	56.8	44.3	59	33.3	51.9	49.8	54.8	45.2	56.9	34	49.1	47.5	51.8	
	90	55.6	51.4	57.4	49.2	58.6	40.6	53.6	52.4	55.4	50.2	56.5	41.4	50.8	50.1	52.4	
1800	75	52.3	41.6	57.8	31.5	62.2	13.9	50.5	42.4	55.8	32.1	60	14.2	47.7	40.5	52.8	
	80	54.6	47.8	58.9	39.5	62.2	25.8	52.6	48.7	56.8	40.2	60	26.3	49.8	46.5	53.7	
	85	56.6	52.4	59.7	47.5	62	35.7	54.6	53.4	57.6	48.4	59.8	36.4	51.7	51	54.5	
	90	58.5	55.1	60.4	52.8	61.6	43.5	56.4	56.2	58.2	53.8	59.5	44.4	53.4	53.4	55.1	
2000	75	53.4	45	59.1	34.1	63.5	15	51.5	45.9	57	34.7	61.3	15.3	48.8	43.8	53.9	
	80	55.7	51.7	60.1	42.7	63.5	28	53.8	52.7	58	43.5	61.3	28.5	50.9	50.3	54.9	
	85	57.8	56.6	61	51.4	63.3	38.7	55.8	55.8	58.8	52.4	61.1	39.4	52.8	52.8	55.7	
	90	59.7	59.7	61.6	57.1	63	47.1	57.6	57.6	59.5	58.2	60.7	48	54.5	54.5	56.3	
2200	75	54.6	45.1	60.4	34.2	64.9	15.1	52.7	46	58.2	34.8	62.6	15.4	49.8	43.9	55.1	
	80	57	51.8	61.5	42.8	64.9	28	55	52.8	59.3	43.6	62.6	28.6	52	50.4	56.1	
	85	59.1	56.8	62.3	51.5	64.8	38.7	57	57	60.1	52.5	62.5	39.5	54	54	56.9	
	90	61.1	59.8	63	57.2	64.4	47.2	58.9	58.9	60.8	58.3	62.1	48.1	55.7	55.7	57.5	
2400	75	55	46.3	60.8	35.1	65.4	15.5	53.1	47.2	58.7	35.7	63.1	15.8	50.2	45.1	55.5	
	80	57.4	53.2	61.9	43.9	65.4	28.8	55.4	53.2	59.7	44.7	63.1	29.3	52.4	51.8	56.5	
	85	59.6	58.3	62.8	52.9	65.3	39.8	57.5	57.5	60.6	53.9	63	40.5	54.4	54.4	57.3	
	90	61.5	61.4	63.5	58.7	64.9	48.4	59.4	59.4	61.3	59.9	62.6	49.4	56.2	56.2	58	
Outdoor	DB	105				115						125					
Indoor	WB	67		73		61		67		73		61		67		73	
CFM	DB	SHC	TGC	SHC	TGC	SHC	TGC	SHC	TGC	SHC	TGC	SHC	TGC	SHC	TGC	SHC	
1600	75	28.6	53.9	12.6	42.4	36.4	46.9	27.6	50.4	12.2	38.9	34.4	43	26.1	46.2	11.5	
	80	35.8	54	23.5	44.3	41.8	47.7	34.5	50.4	22.6	40.6	39.5	43.8	32.6	46.3	21.4	
	85	43.1	53.8	32.5	45.9	45.8	48.4	41.6	50.3	31.3	42.1	42.1	44.4	39.3	46.1	29.6	
	90	47.9	53.5	39.5	47.4	47.4	48.9	46.2	50	38.1	43.5	43.5	44.9	43.7	45.9	36	
1800	75	30.7	56.7	13.5	44.6	39	49.3	29.6	53	13.1	40.9	36.9	45.2	27.9	48.6	12.3	
	80	38.4	56.8	25.2	46.5	44.8	50.2	37	53.1	24.3	42.7	42.4	46.1	35	48.7	22.9	
	85	46.3	56.6	34.8	48.3	48.3	50.9	44.6	52.9	33.5	44.3	44.3	46.7	42.1	48.5	31.7	
	90	51.4	56.3	42.4	49.9	49.9	51.5	49.5	52.6	40.8	45.8	45.8	47.2	46.8	48.2	38.6	
2000	75	33.2	58	14.6	45.6	42.2	50.4	32	54.2	14.1	41.8	39.9	46.2	30.2	49.7	13.3	
	80	41.6	58	27.2	47.5	47.5	51.3	40.1	54.2	26.2	43.6	43.6	47	37.9	49.7	24.8	
	85	50.1	57.8	37.6	49.3	49.3	52	48.2	54	37.4	45.3	45.3	47.7	45.6	49.6	34.3	
	90	55.6	57.5	45.8	51	51	52.6	52.6	53.7	45.5	46.7	46.7	48.2	48.2	49.3	41.8	
2200	75	33.3	59.2	14.7	46.6	42.3	51.5	32.1	55.4	14.1	42.7	40	47.2	30.3	50.8	13.4	
	80	41.6	59.3	27.3	48.6	48.6	52.4	40.1	55.4	26.3	44.6	44.6	48.1	37.9	50.8	24.8	
	85	50.2	59.1	37.7	50.4	50.4	53.2	48.3	55.2	36.4	46.3	46.3	48.8	45.7	50.7	34.4	
	90	55.7	58.7	45.9	52.1	52.1	53.8	53.7	54.9	44.3	47.8	47.8	49.3	49.3	50.4	41.8	
2400	75	34.1	59.7	15.1	46.9	43.4	51.9	32.9	55.8	14.5	43.1	41.1	47.6	31.1	51.2	13.7	
	80	42.7	59.7	28	49	49	52.8	41.2	55.8	27	44.9	44.9	48.5	38.9	51.2	25.5	
	85	51.5	59.6	38.7	50.8	50.8	53.6	49.6	55.7	37.3	46.6	46.6	49.2	46.9	51.1	35.3	
	90	57.2	59.2	47.2	52.5	52.5	54.2	54.2	55.3	45.4	48.2	48.2	49.7	49.7	50.8	43	

**Notes:**

1. All capacities are net; They account for the effects of the indoor-fan motor power and heat.
2. TOT = Total Cooling Capacity (net)
3. SEN = Sensible Heat Capacity (net)
4. Unit : MBH = 1,000 Btu/h



# Performance data

**Table-5**

**Evaporator Fan Performance Data(LN-0320CC)**

CFM	High Speed		Mid Speed		Low Speed	
	ESP	BHP	ESP	BHP	ESP	BHP
900	1.50	0.23	1.12	0.21	0.80	0.24
1,000	1.30	0.27	0.91	0.26	0.59	0.30
1,100	1.09	0.31	0.71	0.32	0.38	0.36
1,200	0.89	0.36	0.51	0.37	0.16	0.42
1,300	0.66	0.40	0.31	0.43	-	-
1,400	0.49	0.44	0.11	0.48	-	-
1,500	0.29	0.49	-	-	-	-
1,600	0.09	0.53	-	-	-	-

- Fan motor heat(MBH)= 5.09 x Fan Bhp
- Test Condition: ① Voltage : 220V  
② Operating Mode: Fan operation mode with clean filter, dry coil, without electric heater.
- Do not operate the unit at a cooling airflow that is less than 300cfm/12MBH.

**Table-6**

**Evaporator Fan Performance Data(LN-0420CC)**

CFM	High Speed		Mid Speed		Low Speed	
	ESP	BHP	ESP	BHP	ESP	BHP
1,300	0.86	0.35	0.77	0.32	0.64	0.31
1,400	0.77	0.37	0.67	0.34	0.54	0.33
1,500	0.68	0.39	0.58	0.36	0.45	0.35
1,600	0.60	0.41	0.49	0.38	0.35	0.37
1,700	0.51	0.43	0.40	0.40	0.25	0.39
1,800	0.42	0.44	0.30	0.42	0.15	0.42
1,900	0.33	0.46	0.21	0.44	-	-
2,000	0.25	0.48	0.12	0.46	-	-
2,100	0.16	0.50	0.03	0.48	-	-
2,200	0.07	0.52	-	-	-	-

- Fan motor heat(MBH)= 5.09 x Fan Bhp
- Test Condition: ① Voltage : 220V  
② Operating Mode: Fan operation mode with clean filter, dry coil, without electric heater.
- Do not operate the unit at a cooling airflow that is less than 300cfm/12MBH.

**Table-7**

**Evaporator Fan Performance Data(LN-0520CC)**

CFM	High Speed		Mid Speed		Low Speed	
	ESP	BHP	ESP	BHP	ESP	BHP
1,400	0.93	0.48	0.81	0.39	0.68	0.38
1,500	0.86	0.51	0.74	0.42	0.59	0.41
1,600	0.79	0.53	0.67	0.45	0.50	0.44
1,700	0.73	0.55	0.60	0.48	0.41	0.48
1,800	0.66	0.58	0.53	0.51	0.32	0.51
1,900	0.59	0.60	0.45	0.53	0.24	0.54
2,000	0.52	0.62	0.38	0.56	0.15	0.57
2,100	0.46	0.65	0.31	0.59	0.06	0.61
2,200	0.39	0.67	0.24	0.62	-	-
2,300	0.32	0.69	0.17	0.65	-	-
2,400	0.25	0.72	0.10	0.68	-	-
2,500	0.19	0.74	0.03	0.70	-	-
2,600	0.12	0.76	-	-	-	-
2,700	0.05	0.79	-	-	-	-

- Fan motor heat(MBH)= 5.09 x Fan Bhp
- Test Condition: ① Voltage : 220V  
② Operating Mode: Fan operation mode with clean filter, dry coil, without electric heater.
- Do not operate the unit at a cooling airflow that is less than 300cfm/12MBH.



# Performance data

**Table-8** Wet coil pressure drop

UNIT SIZE	AIRFLOW(cfm)	PRESSURE DROP(in.wg)
LN-0320CC	1,000	0.07
	1,200	0.09
	1,400	0.11
	1,600	0.12
LN-0420CC	1,400	0.07
	1,600	0.08
	1,800	0.09
LN-0520CC	1,700	0.07
	1,800	0.08
	2,100	0.09
	2,300	0.10

**Table-9** Accessory Static Pressure Drops (in. aq)

Unit Model No.	cfm	Free Filter	Electric Heater		
			5KW	10KW	15KW
LN-0320CC	960	0.02	0.01	0.01	0.02
	1200	0.03	0.01	0.01	0.02
	1440	0.03	0.02	0.02	0.03
LN-0420CC	1280	0.03	0.01	0.01	0.03
	1600	0.03	0.02	0.02	0.04
	1960	0.05	0.03	0.04	0.07
LN-0520CC	1600	0.03	0.02	0.02	0.03
	2000	0.05	0.03	0.04	0.06
	2400	0.07	0.04	0.05	0.09

**Table-10** Electric Heating Capacity

MODEL	Total		No. of Stages	Stage 1	
	Input(kw)	Output(MBH)		Input(kw)	Output(MBH)
LN-0320CC	5	17.07	1	5	17.07
	10	34.14	1	10	34.14
	15	68.28	1	15	68.28
LN-0420CC	5	17.07	1	5	17.07
	10	34.14	1	10	34.14
	15	68.28	1	15	68.28
LN-0520CC	5	17.07	1	5	17.07
	10	34.14	1	10	34.14
	15	68.28	1	15	68.28

**Note:** 1. The output ratings shown above is at 240V.  
 For other voltage, Output = Capacity Multiplier x Rated Output  
 2. E/heater Voltage range is 208~240V.

Voltage	Capacity Multiplier
208	0.75
220	0.84
230	0.92
240	1

**Table-11** Air Temperature Rise Across Electric Heater(°F)

Capacity	Stage	LN-0320CC (1200CFM)	LN-0420CC (1600CFM)	LN-0520CC (2000CFM)
5KW	1	13.2	9.9	7.9
10KW	1	26.3	19.8	15.8
15KW	1	39.5	29.6	23.7

- Temp. Rise across Electric Heater =  $\frac{(KW \times 3413)}{(1.08 \times CFM)}$
- If you want to take temp rise at different airflow use above equation.



## Electrical Requirements

**Table-12** Cooling

Tons	MODEL	Unit Operating Voltage Range	Standard indoor fan motor		
			*M.C.A.	*M.F.S.	*M.C.B
3	LN-0320CC	198~242	23.8	30	30
4	LN-0420CC	198~242	28.8	40	40
5	LN-0520CC	198~242	38.1	50	50

**Note:** \*M.C.A.: Minimum Circuit Ampacity  
 \*M.F.S.: Maximum Fuse Size  
 \*M.C.B.: Maximum Circuit Breaker

**Table-13** Electric Heating

MODEL	HEATER MODEL NO.	HEATER CAPACITY(kW)	POWER SUPPLY	Standard indoor fan motor		
				*M.C.A.	*M.F.S.	*M.C.B
LN-0320CC	LKAEH0521	5	1Ø, 220V, 60Hz	28.5	40	40
	LKAEH1021	10		54.6	60	60
	LKAEH1521	15		80.6	90	90
LN-0420CC	LKAEH0521	5	1Ø, 220V, 60Hz	29.0	40	40
	LKAEH1021	10		55.1	60	60
	LKAEH1521	15		81.1	90	90
LN0520CC	LKAEH0521	5	1Ø, 220V, 60Hz	29.1	40	40
	LKAEH1021	10		55.2	60	60
	LKAEH1521	15		81.2	90	90

**Note:** ❶ The heater Capacity shown above is at 240V.  
 ❷ Voltage range is 208~240V.  
 \*M.C.A.: Minimum Circuit Ampacity  
 \*M.F.S.: Maximum Fuse Size  
 \*M.C.B.: Maximum Circuit Breaker

# Electrical Requirements

---

**Table-14**

Evaporator Fan Motor --- 60 Hz

MODEL	Standard indoor fan motor				
	No	Volts	Phase	HP	FLA
LN-0320CC	1	220	1	0.46	5.0
LN-0420CC	1	220	1	0.46	5.0
LN-0520CC	1	220	1	0.46	5.0

**Table-15**

Compressor and Outdoor Fan Motor --- 60 Hz

MODEL	COMPRESSOR						OUTDOOR FAN MOTOR				
	No	Volts	Phase	HP	FLA	LRA	No	Volts	Phase	HP	FLA
LN-0320CC	1	208-230	1	3.0	19.0	105	1	220	1	0.12	1.2
LN-0420CC	1	208-230	1	4.0	19.2	110	1	220	1	0.28	1.8
LN-0520CC	1	208-230	1	5.0	34.3	142	1	220	1	0.28	1.8



# Wiring Diagram

## LN-0520CC/0420CC

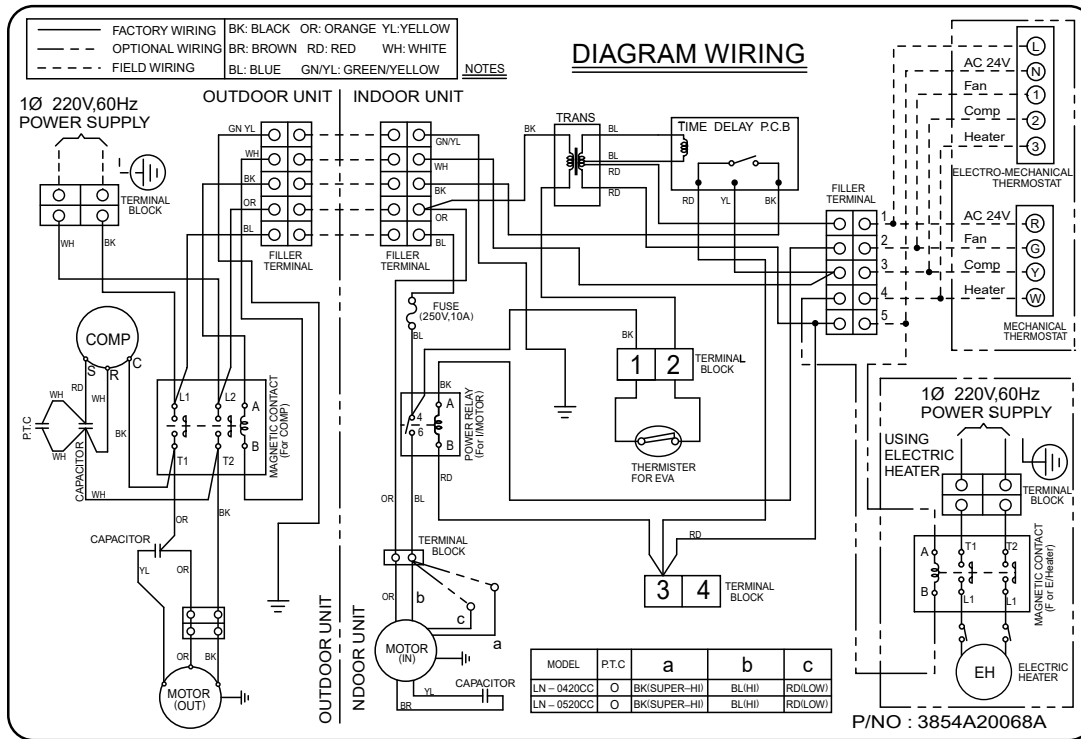

## LN-0320CC

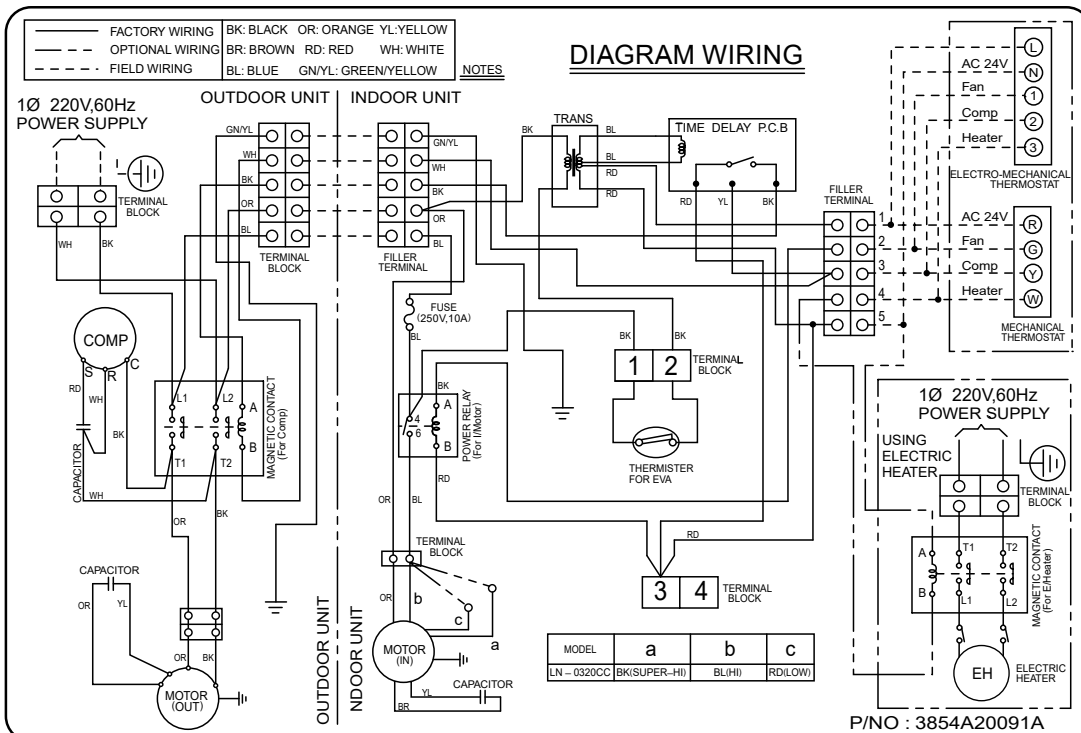

# Dimensions

## LN-0320CC/LN-0420CC/LN-0520CC

### 1. Indoor unit

#### Unit Dimensions

Unit: inch(mm)

MODEL	LN-0320CC	LN-0420/0520CC
A	18.5 (470)	23.6 (600)
B	18.9 (480)	19.7 (500)
C	39.9 (1014)	44.7 (1135)
D	3.3 (84)	5.4 (136)
E	11.9 (303)	13.0 (329)
F	5.6 (142)	7.1 (181)
G	12.0 (304)	12.6 (319)
H	0.6 (15)	0.6 (15)
I	4.3 (110)	6.7 (170)
J	6.3 (160)	9.4 (240)
K	1.7 (43)	2.5 (64)
L	2.0 (50)	2.8 (71)
M	2.0 (52)	2.3 (58)
N	1.8 (45)	2.1 (54)
P	1.3 (32)	1.5 (38)
Q	8.7 (221)	11.2 (285)
R	19.1 (485)	23.0 (584)

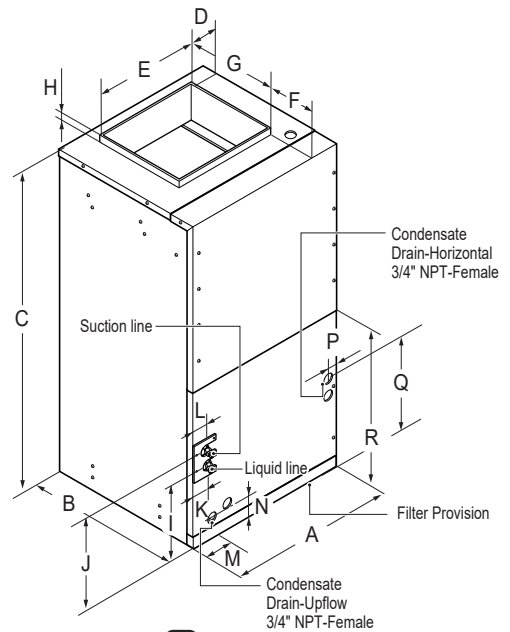

### 2. Outdoor unit

#### LN-0320CC

Unit: inch(mm)

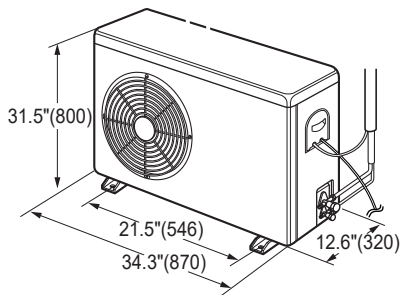

#### LN-0420CC LN-0520CC

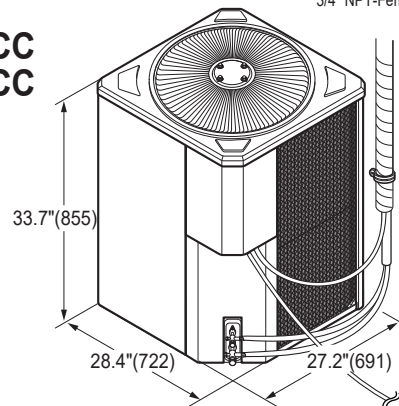

### 3. Type of applications

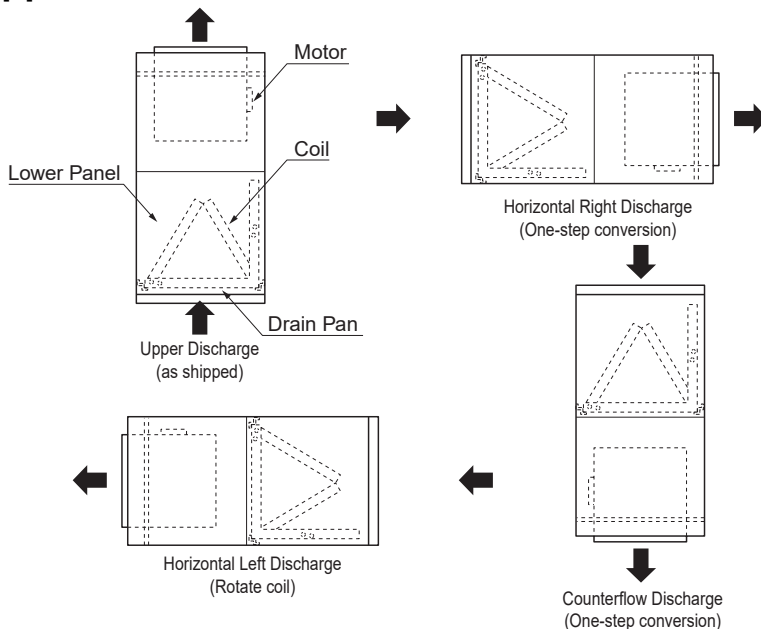



## Mechanical Specifications

### General

Air handling units shall be completely factory assembled including coil drain pan, Blower motor and controls in an insulated casing that can be applied in horizontal or vertical configuration.

Units shall be rated in accordance with ARI standard testing procedure, fully charged with R-22. Units shall fully factory test before shipment.

### Casing

Unit casing shall be constructed of having gauge zinc coated, galvanized steel. The cabinet shall be exterior painted and weather resistance.

The condensing units shall have a water and air tight service panels with minimum number of screws per panel for easy servicing.

### Compressors

LG Ducted Split System units shall be direct drive hermetic compressor, reciprocating type with internal built in lubricating mechanism for all moving parts. Motor shall be suction gas cooled with internal temperature and over current sensitive motor over load, for maximum protection. Factory rubber shock mounted and internally spring isolation for sound and vibration control.

### Refrigerant Circuits

Each refrigerant circuit shall have independent fixed capillary tube devices and service pressure ports, and refrigerant line filter factory-installed as standard.

### Evaporator and Condenser Coils

Shall be aluminum plate fins, mechanically bonded to copper tubes.

Coil shall be factory test for leakage and pressure.

### Outdoor Fans

Statically and dynamically, direct drive outdoor fan in vertical discharge position. Permanently lubricated fan motors with built in thermal overload protection.

### Indoor Fan

Direct drive indoor motors for all unit with forward curve centrifugal fans. All motors shall be thermally overload protected.

### Controls

All units shall be supply heating and cooling by thermostat.

Time delay PCB shall provide time delay between Fan and Compressor.

# Specification of Components

		<b>LN-0320CC</b>	<b>LN-0420CC</b>	<b>LN-0520CC</b>	
Comp	P/No.	2A01169A	5417A20009A	2A01094E	
	MODEL NAME	CR38K6-PFV-502	AVD5548EXN	CRN5-0500-PFV	
	RLA	19	19.2	34.3	
	LRA	105	110	142	
	QUANTITY	1	1	1	
INDOOR MOTOR	P/No.	4681A20022H	4681A20022H	4681A20022G	
	OUTPUT	347 W	347 W	545 W	
	SHAFT DIA	15mm	15mm	15mm	
	RPM	995 (Hi)	995 (Hi)	1,080 (Hi)	
OUTDOOR MOTOR	P/No.	4681A20008M	4681A20039A	4681A20039A	
	OUTPUT	90 W	207 W	207 W	
	SHAFT DIA	12mm	15mm	15mm	
	RPM	930	970	970	
QUANTITY	QUANTITY	1	1	1	
	OUTDOOR FAN	P/No.	1A00195B	5901A10010A	5901A10010A
		Diameter	460 mm	556 mm	556 mm
	INDOOR BLOWER	P/No.	2A00278U	2A00278M	2A00278M
Diameter*Width		190mm * 182mm	190mm * 270mm	190mm * 270mm	
CAPACITOR for COMP	P/No.	2A00986B	2A00986A	6120AR2194T	
	SPEC	40μF, 370/400V, 50/60Hz	45μF, 370/400V, 50/60Hz	55μF, 370/400V, 50/60Hz	
CAPACITOR for IDM	P/No.	2A00986D	0CZZA20001B	0CZZA20001B	
	SPEC	6μF, 370/400V, 50/60Hz	15μF, 450V, 50Hz, 50MM	15μF, 450V, 50Hz, 50MM	
CAPACITOR for ODM	P/No.	2A00986D	2A00986D	2A00986D	
	SPEC	6μF, 370/400V, 50/60Hz	6μF, 370V/400, 50/60Hz	6μF, 370V/400, 50/60Hz	
FILTER	P/No.	5230A20003K	5230A20003J	5230A20003J	
	SIZE	460mm * 460mm	582mm * 484mm	582mm * 484mm	
	QUANTITY	1	1	1	
CAPILLARY TUBE	P/No.	3H01535E	5426AR3147P	3E92334N	
	SPEC	ID1.6 * 900mm	ID1.6 * 900mm	ID1.4 * 760mm	
	QUANTITY	4	4	6	
TRANSFORMER	P/No.	6171AQ2138G	6171AQ2138G	6171AQ2138G	
	SPEC	AC 250V/2A	AC 250V/2A	AC 250V/2A	
	QUANTITY	1	1	1	
CONTACTOR for COMP	P/No.	2A00771F	2A00771F	2A00771F	
	SPEC	40A, 24V CONTROL	40A, 24V CONTROL	40A, 24V CONTROL	
RELAY for IDM	P/No.	6920AP3194B	6920AP3194B	6920AP3194B	
	SPEC	AC 24V, 20A	AC 24V, 20A	AC 24V, 20A	