

IT BRUCIATORI MISTI GAS / OLIO COMBUSTIBILE

EN GAS / HEAVY-OIL DUAL BURNERS

FR BRULEURS MIXTE GAZ + FUEL LOURD

ES QUEMADORES MIXTOS GAS / FUEL PESADO

RU КОМБИНИРОВАННЫЕ ГОРЕЛКИ ГАЗ / МАЗУТ

Ecoflam



Multiflam 700.1

Multiflam 800.1

Multiflam 1000.1

Multiflam 1200.1

PR/PR

TS



420010311100

420010311100

14.06.2010

Indice**1 - Dati tecnici**

- Caratteristiche tecnichep.3
- Dimensioni di ingombrop.3

2 - Installazione

- Allacciamento elettricop.4
- Allacciamento gasp.4

3 - Avviamento e regolazioni gas

- Funzionamento del bruciatorep.4
- Regolazione della combustionep.4
- Funzionamento apparecchiatura di controllop.5
- Regolazioni aria / gasp.5,6
- Regolazioni testa / pressostatip.7
- Controllo sistema di rivelazione fiammap.7
- Smontaggio testap.8

4 - Avviamento e regolazioni olio

- Collegamento olio combustibile al bruciatorep.8
- Verifichep.8
- Funzionamento del bruciatorep.9
- Regolazionip.9
- Schema idraulicop.10,11
- Posizione e pulizia elettrodip.12
- Tabella ugellip.13,14,15,16,17

5 - Uso e manutenzione

- Anomalie di funzionamentop.18

CARATTERISTICHE TECNICHE

MODELLO		Multiflam 700.1	Multiflam 800.1	Multiflam 1000.1	Multiflam 1200.1
Potenza termica max.	kW	7.500	8.500	10.500	13.000
	kcal/h	6.465.000	7.327.500	9.052.000	11.207.000
Potenza termica min.	kW	1.500	2000	2500	2.700
	kcal/h	1.290.000	1.724.000	2.155.000	2.327.600
Pressione Gas metano	mbar	60÷700	85÷700	115÷700	160÷700
Pressione GPL	mbar	125÷700	185÷700	110÷700	160÷700
Tensione di alim. 50 Hz	V	230/400	230/400	230/400	230/400
Combustibile :	Gas Naturale (P.C.I. 8.570 kcal/Nm ³), GPL (P.C.I. 22.260 kcal/Nm ³) Olio combustibile (P.C.I. 9.800 kcal/kg max. visc 50°E a 50°C)				

DIMENSIONI D'INGOMBRO

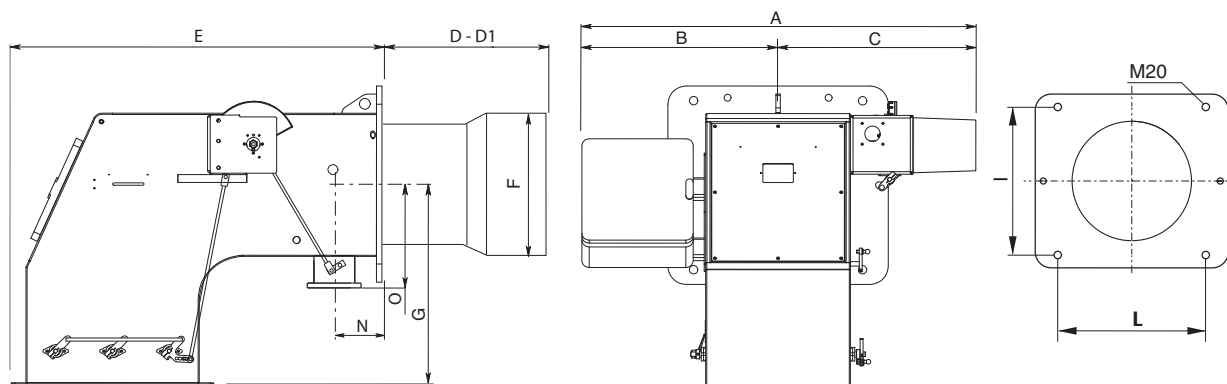

D = testa corta D1 = testa lunga Dimensioni (mm)

MODELLO	A	B	C	D	D1	E	F	G	I	L	M	N	O
Multiflam 700.1 TS	1170	540	630	470	-	1030	420	550	460	460	M20	195	232
Multiflam 800.1 TS	1170	540	630	470	-	1030	420	550	460	460	M20	195	232
Multiflam 1000.1 TS	1170	540	630	470	-	1030	420	550	460	460	M20	195	232
Multiflam 1200.1 TS	1170	540	630	470	-	1030	450	550	460	460	M20	195	232

FLANGIA ARIA

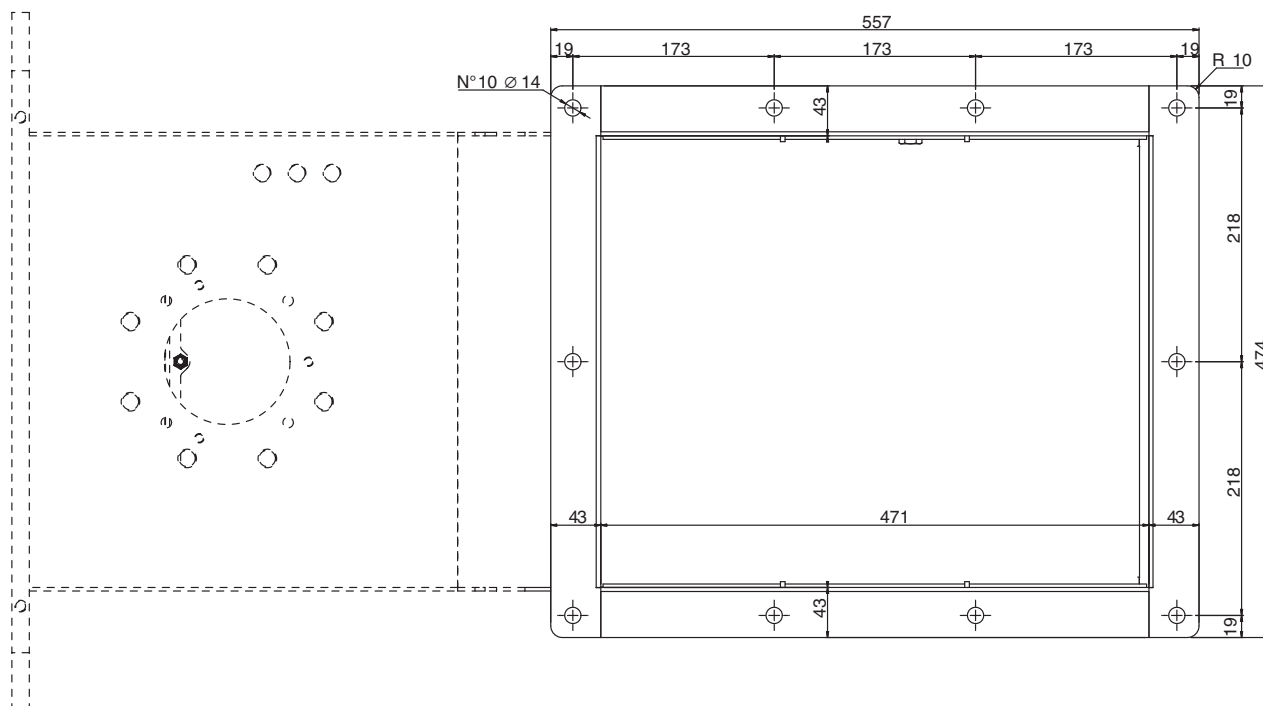

ALLACCIAMENTO ELETTRICO

Tutti i bruciatori sono collaudati a 400 V 50 Hz trifase per i motori e 230V 50 Hz monofase con neutro per gli ausiliari. Se fosse necessario alimentare il bruciatore a 230 V 50 Hz trifase senza neutro, eseguire le modifiche necessarie riferendosi allo specifico schema elettrico del bruciatore e controllare che il relé termico sia entro il campo di assorbimento del motore. Accertare inoltre il corretto senso di rotazione del motore del ventilatore.

ALLACCIAMENTO ALLA LINEA GAS

Allacciato il bruciatore alla tubazione del gas è necessario assicurarsi che quest'ultima sia a tenuta perfetta. Assicurarsi pure che il camino non sia ostruito. Aperto il rubinetto del gas sfiatare con prudenza la tubazione attraverso l'apposita presa di pressione e quindi controllare il valore della pressione con un manometro idoneo. Dare tensione all'impianto e regolare i termostati alla temperatura desiderata. Alla chiusura dei termostati, il dispositivo di controllo fughe gas effettua una prova di tenuta delle valvole; Al termine della prova il bruciatore riceve il consenso per effettuare il ciclo di avviamento.

AVVIAMENTO DEL BRUCIATORE LATO GAS

Prima di accendere il bruciatore, assicurarsi che sia montato correttamente. Controllare i collegamenti elettrici secondo i diagrammi e le tubazioni dell'impianto. Prima del collegamento elettrico assicurarsi che il voltaggio corrisponda ai dati indicati nella targhetta caratteristiche. Il diagramma del collegamento elettrico e il ciclo di avviamento sono illustrati separatamente. Per collegare l'apparecchiatura al bruciatore, vedere lo schema. Prestare particolarmente attenzione al collegamento del neutro e della fase: non scambiarli mai. Controllare il collegamento terra dell'impianto. Nei motori trifase controllare il senso di rotazione del motore (vedere freccia). Sfiatare l'aria e le impurità della tubazione del gas. Controllare che la pressione del gas sia nei limiti indicati nella targhetta. Questo controllo deve essere effettuato con un manometro gas nell'apposita presa di pressione prevista sul bruciatore. Si avvia il motore ed inizia la preventilazione. Il motoriduttore porta la serranda dell'aria alla massima apertura in circa 30 secondi. Quando il motoriduttore è completamente aperto, un segnale all'apparecchiatura elettronica di controllo avvia un ciclo di preventilazione di circa 66 secondi (36 sec.LFL1.133). Alla fine di questa preventilazione, il motoriduttore porta la serranda in bassa fiamma permettendo l'accensione del bruciatore alla minima portata. Contemporaneamente il trasformatore di accensione viene alimentato e dopo tre secondi (pre-accensione) vengono alimentate le valvole del gas. A questo punto la valvola a farfalla regola la portata del gas nella testa di combustione. Due secondi dopo l'apertura delle valvole, il trasformatore è escluso dal circuito. In caso di mancanza di accensione il bruciatore va in blocco entro due secondi. Il bruciatore si trova acceso alla minima potenza (circa 30% della massima potenza). Lo strumento modulatore farà aprire il servomotore alla massima potenza o lo fermerà alla potenza intermedia richiesta dall'impianto. L'apertura del servomotore farà aprire gas ed aria in modo proporzionale per avere sempre a tutte le portate (30%-100%) una combustione ottimale. Al termine del funzionamento il servomotore si porta in posizione di chiusura.

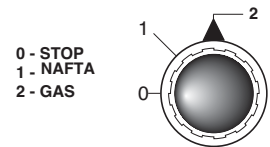

REGOLAZIONE DELLA COMBUSTIONE

ATTENZIONE: per ottenere una corretta regolazione della combustione e della portata termica occorre effettuare l'analisi dei fumi, servendosi degli appositi strumenti. La regolazione della combustione e della portata termica va eseguita contemporaneamente ad una analisi dei prodotti della combustione, assicurandosi che i valori riscontrati siano corretti, e, in ogni caso, rispondenti alle normative di sicurezza vigenti. A tal proposito vedere la tabella e la figura sottostanti. **TALE OPERAZIONE DEVE ESSERE ESEGUITA DA PERSONALE PROFESSIONALMENTE QUALIFICATO ED AUTORIZZATO DALLA ECOFLAM BRUCIATORI SPA.**

NB-TUTTI GLI ORGANI DI SICUREZZA (PRESSOSTATO ARIA, PRESSOSTATO GAS DI MINIMA, ELETTROVALVOLE GAS E STABILIZZATORE DI PRESSIONE) DOVRANNO ESSERE OPPORTUNAMENTE SIGILLATI DOPO LA TARATURA E MESSA IN FUNZIONE DEI BRUCIATORI DA PARTE DEL PERSONALE QUALIFICATO E AUTORIZZATO ECOFLAM BRUCIATORI SPA.

CICLO DI FUNZIONAMENTO DELL'APPARECCHIATURA LANDIS & STAEFA MOD. LFL1.622-1.333

Rif.	descrizione	durata
t1	tempo di attesa della conferma della pressione dell'aria	8"
t2	tempo di preventilazione	66" (36")
t3	tempo di sicurezza	2"
t4	tempo di preaccensione	4"
t5	tempo per il consenso di funzionam. alla minima potenza della valvola di lavoro del combustibile	10"
t6	tempo per il consenso di funzionam. alla massima potenza della valvola di lavoro del combustibile	10"

L'apparecchiatura controllo fiamma fa partire il ventilatore del bruciatore per effettuare il prelavaggio della camera di combustione, controllando la pressione dell'aria di ventilazione tramite il pressostato aria. Al termine della preventilazione entra in funzione il trasformatore di accensione generando una scintilla

tra gli elettrodi e contemporaneamente si aprono le valvole del gas (valvole gas di sicurezza VS e valvola di lavoro VL). La sicurezza totale in caso di mancata accensione o di spegnimento accidentale viene affidata a una sonda di rivelazione che interviene mandando in blocco l'apparecchiatura entro il tempo di sicurezza. Nel caso di mancanza di gas o di un calo notevole di pressione il pressostato gas di minima provvede ad interrompere il funzionamento del bruciatore.

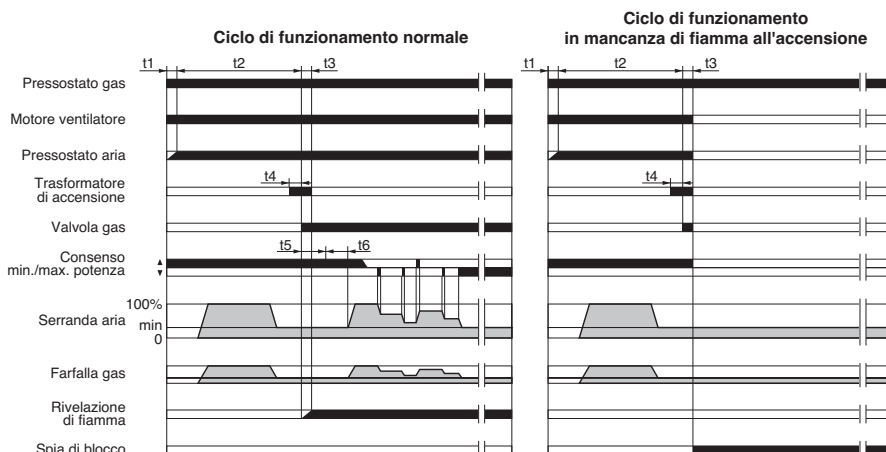

REGOLAZIONE DEL MOTORIDUTTORE LANDIS & STAEFA SQM 50.481A2

Togliere il coperchio per accedere alle camme di regolazione. Lo spostamento delle camme va effettuato con l'ausilio dell'apposita chiavetta in dotazione.

Descrizione :



Multiflam 700.1-1200.1 PR/PR

- I - Camma di regolazione aria alta fiamma(GAS-NAFTA).
- II - Camma di regolazione della posizione serranda aria allo spegnimento(chiusura).
- III - Camma di regolazione aria partenza a (GAS).
- IV - Camma di regolazione aria partenza a (NAFTA).
- V - Camma di regolazione aria bassa fiamma GAS.
- VI - Camma di regolazione aria bassa fiamma NAFTA.
- VII - Camma di regolazione aria alta fiamma GAS.
- VIII - Camma di consenso non usata.

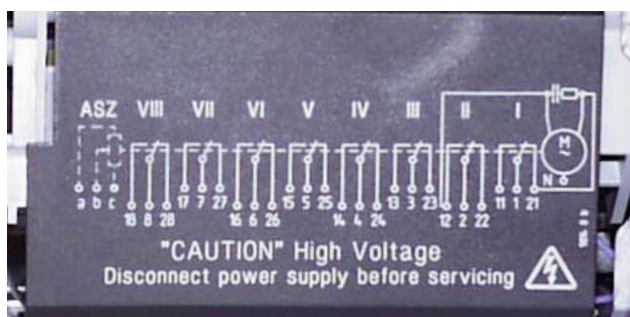

CALCOLO PORTATA BRUCIATORE

Per calcolare la portata in kW del bruciatore, procedere nel modo seguente :
Controllare al contatore la portata in litri del gas e il tempo in secondi della lettura.

Procedere al calcolo secondo la formula : $\frac{e}{sec} \times f = kW$

$$f \begin{cases} G20 = 34,02 \\ G25 = 29,25 \\ G30 = 116 \\ G31 = 88 \end{cases}$$

REGOLAZIONE DELLA PORTATA ARIA E GAS

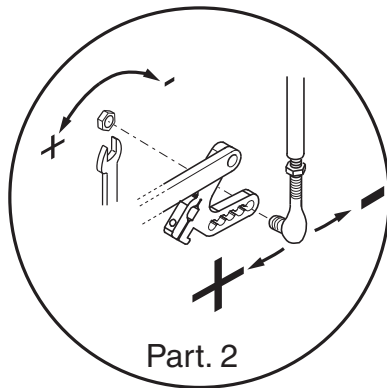

COMMUTATORE

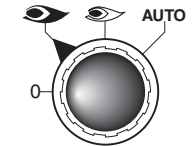

- 0 = bloccaggio degli apparati per il funzionamento in una posizione intermedia
- 1 = funzionamento alla massima potenza
- 2 = funzionamento alla minima potenza
- AUTO = funzionamento automatico

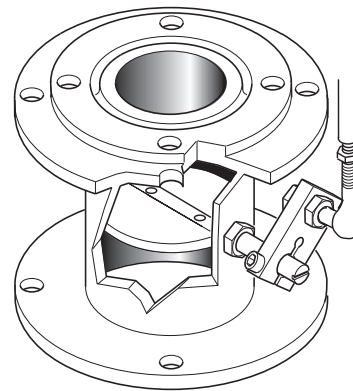
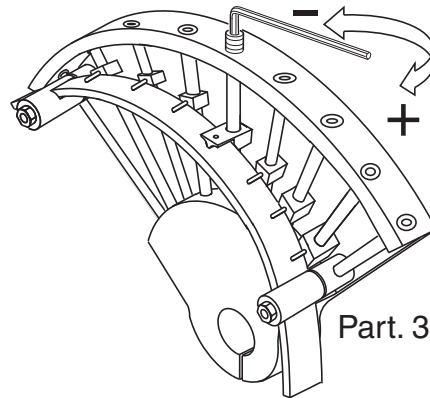

REGOLAZIONE DELLA POTENZA MINIMA DEL GAS

Posizionare il commutatore che si trova sulla mostrina in posizione 2 e agire come segue:

Per regolare la portata minimo del gas agire con la chiave a brugola sulla vite della camma e modificare l'angolo della serranda gas della valvola a farfalla.

REGOLAZIONE DELLA POTENZA MASSIMA DEL GAS

Posizionare il commutatore che si trova sulla mostrina in posizione 1 e agire come segue:

Per regolare la portata massimo del gas agire sull'elettrovalvola di regolazione fino a ottenere il valore corretto per la caldaia.

REGOLAZIONE DELLA PORTATA MASSIMA DELL'ARIA

Svitare la vite di fissaggio dell'asta e mettere la stessa nella posizione corretta.

Alla fine della regolazione richiudere la vite dell'asta.

REGOLAZIONE DELLA PORTATA INTERMEDIA DEL GAS

Azionare il servomotore con il commutatore (aperto/chiuso) e posizionarlo nella posizione 0 per fermarlo. Per la regolazione, agire come segue. Ripetere i passaggi per gli altri punti delle camme.

Regolazione della portata intermedia del gas (vedere immagine 3):

Con una chiave a brugola modificare la posizione della lamina guida della camma, chiudendo la portata aumenta, aprendo la portata diminuisce.

REGOLAZIONE DELLA COMBUSTIONE

ATTENZIONE: Ai fini di una corretta regolazione della combustione e della portata termica, queste vanno eseguite contemporaneamente ad una analisi dei fumi, da effettuarsi con strumenti appositi, controllando che i valori riscontrati siano corretti e rispondenti alle normative di sicurezza in vigore. Le operazioni di regolazione debbono essere effettuate da personale qualificato ed autorizzato dalla Ecoflam bruciatori S.p.A.

REGOLAZIONE TESTA DI COMBUSTIONE

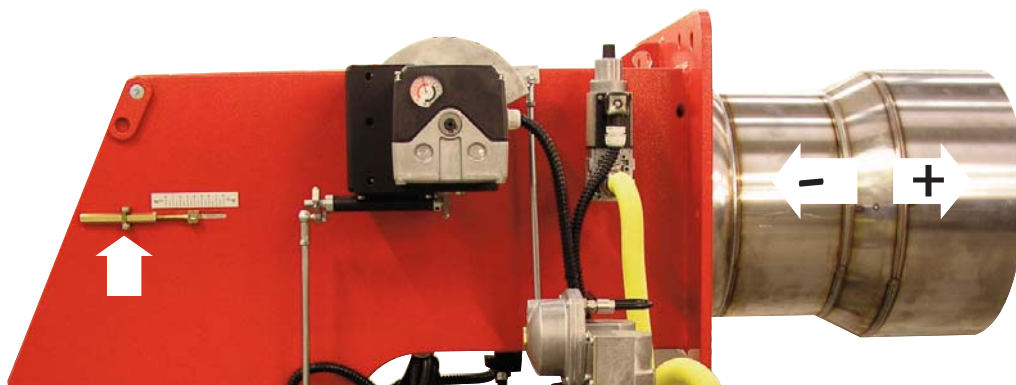

TARATURA DEL PRESSOSTATO GAS DI MINIMA PRESSIONE

Svitare le viti I e L e togliere il coperchio M. posizionare il regolatore N ad un valore pari al 60% della pressione nominale di alimentazione gas (es.: per gas metano press. nominale =20 mbar; regolatore posizionato al valore 12 mbar; per G.P.L. pressione nominale G30-G31 30/37 mbar regolatore posizionato al valore di 18 mbar). - rimontare il coperchio M e riavvitare le viti I e L.

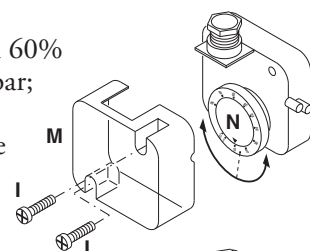

REGOLAZIONE DEL PRESSOSTATO ARIA

Svitare le viti A e B e rimuovere il coperchio C. - Regolare il pressostato aria al minimo ruotando il regolatore D in posizione 1. - Avviare il bruciatore ed impostare il funzionamento in 1° stadio (1 fiamma) verificando che la combustione sia corretta. Servendosi di un cartoncino, ostruire progressivamente il condotto di aspirazione aria, sino ad ottenere un aumento del valore della CO₂ pari al 0,5÷0,8% oppure, se si dispone di un manometro collegato alla presa di pressione E, sino ad ottenere una diminuzione di pressione di 1 mbar (10 mm C.A.). Aumentare progressivamente il valore di taratura del pressostato sino a causare lo spegnimento in blocco del bruciatore. Rimuovere l'ostruzione dal condotto, rimontare il coperchio C e ripristinare il funzionamento del bruciatore agendo sul pulsante di riarmo del blocco dell'apparecchiatura.

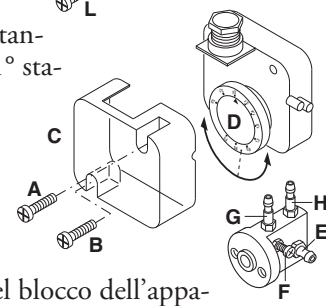

NB: La pressione misurata alla presa E deve rientrare nel campo di lavoro del pressostato. Se così non fosse, allentare il dado di bloccaggio della vite F ed agire gradualmente sulla stessa: in senso orario per ridurre la pressione; in senso antiorario per aumentarla. Al termine della regolazione fissare il dado.

CONTROLLO SISTEMA DI RILEVAZIONE FIAMMA

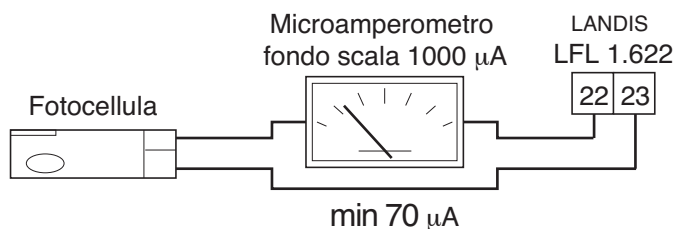

Il controllo della corrente di rivelazione si effettua inserendo un microamperometro con fondo scala di 1000 µA (corrente continua) in serie alla fotocellula. Normalmente il valore minimo della corrente di rivelazione è >70 µA.

SMONTAGGIO BOCCAGLIO

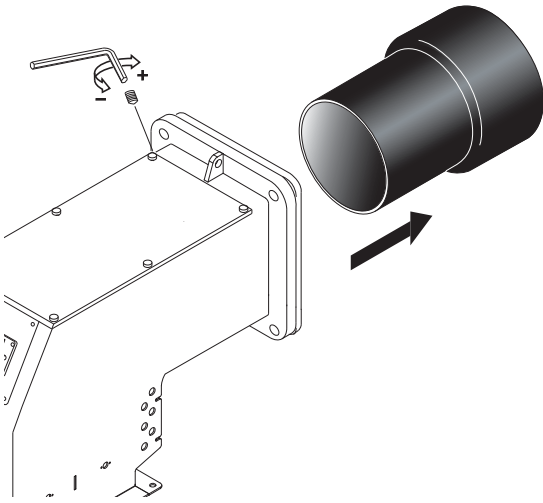

SMONTAGGIO TESTA DI COMBUSTIONE

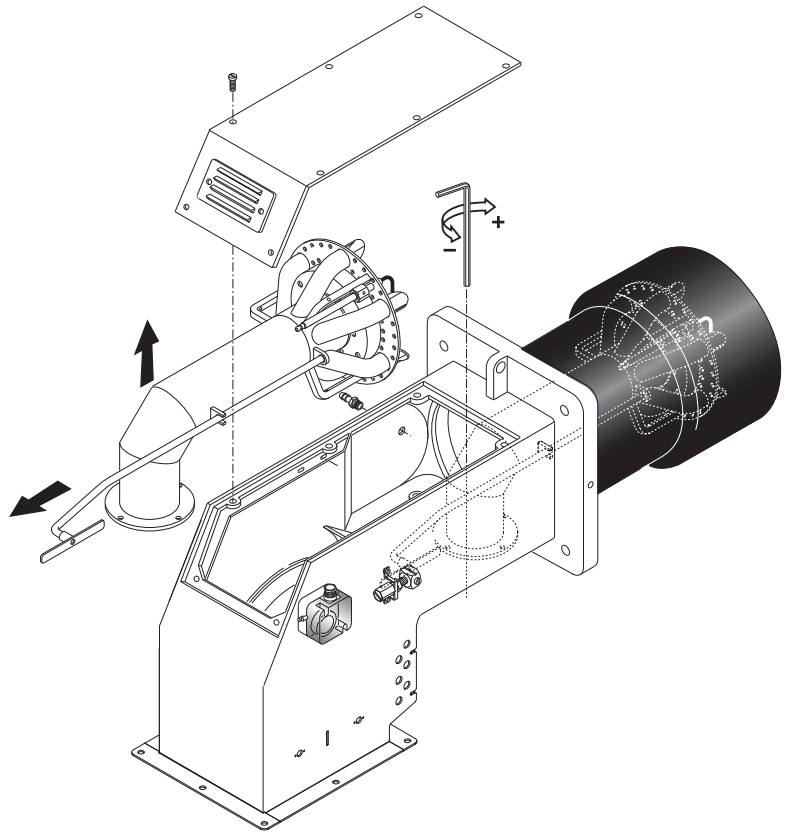

COLLEGAMENTO OLIO COMBUSTIBILE AL BRUCIATORE



VERIFICHE DA EFFETTUARE AI FINI DI UNA CORRETTA INSTALLAZIONE:

Prima di procedere al riempimento del circuito di alimentazione e successiva messa in funzione dell'impianto, è consigliabile effettuare i controlli seguenti:

- La linea di alimentazione deve essere adeguata al carico assorbito dall'impianto
- I fusibili devono essere adeguati al carico dall'impianto
- I termostati caldaia devono essere stati collegati correttamente
- Tensione e frequenza devono essere comprese nei limiti specificati
- Il tipo di combustibile deve essere quello prescritto dal costruttore del bruciatore
- La sezione delle tubazioni di alimentazione deve essere adeguata alla portata di combustibile richiesta
- I filtri ed i rubinetti ed i raccordi devono essere stati montati correttamente
- La lunghezza del boccaglio del bruciatore, deve essere quella prescritta dal costruttore della caldaia
- La portata degli ugelli del bruciatore deve essere adeguata alla potenza della caldaia

FUNZIONAMENTO DEL BRUCIATORE

Con il bruciatore nella posizione start e i termostati caldaia abilitati, le resistenze (G) del preriscaldatore, le resistenze ausiliarie su pompa e gruppo testa sono sotto tensione. Quando il termostato del preriscaldatore raggiunge il valore fissato, (normalmente è necessario un minimo di 90°C per garantire un buon livello di circolazione) la pompa di avviamento è abilitata (se si usa il dispositivo di termoregolazione GEFTRAN 200 regolare il set point nell'uscita 1). Se il sistema di preriscaldamento del serbatoio è equipaggiato anche per uno scambiatore di liquidi (acqua calda, vapore, olio diatermico) il termostato può abilitare un contatto nella morsetteria per qualsiasi consenso elettrico dell'elettrovalvola per liquidi. Questa non è una soluzione standard visto che il fluido riscaldato normalmente è sempre in circolazione. La pompa inizia a mandare olio (la testa è già stata riscaldata dalla sua resistenza (O) e perciò non ha residuo di olio denso freddo) che scorre dal serbatoio alla testa e poi alla linea di ritorno dell'anello di alimentazione dell'olio. Quando il termostato della testa raggiunge il valore fissato (normalmente il ciclo comincia in maniera appropriata a circa 70-30°C e l'apparecchiatura da il consenso all'avvio del bruciatore. Il servomotore si autoposiziona al minimo (vedi il capitolo della regolazione) agendo sulla serranda dell'aria e agendo sul ritorno del regolatore di pressione per l'olio combustibile.

0 - STOP
1 - NAFTA
2 - GAS

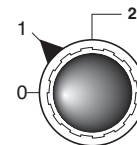

L'elettromagnete (A) apre l'ugello (Q) nella seguente condizione :

- le scintille degli elettrodi di accensione sono generate dal trasformatore che è anche regolato automaticamente dal dispositivo di controllo del bruciatore.

Se la cellula di rivelazione non rivela la fiamma il bruciatore va in blocco.

Una volta che l'accensione è avvenuta e dopo il periodo di stabilizzazione della fiamma, il sistema inizia a operare in modulazione.

- Prima dell'avvio assicurarsi che la pompa e i tubi di mandata siano completamente riempiti con olio combustibile caldo; l'assenza di olio combustibile può causare il grippaggio della pompa.

- Se c'è un blocco, una luce specifica di avvertimento sul programmatore e sul pannello frontale di controllo del bruciatore si illumina e questo segnale è mandato di solito all'apparecchiatura principale usata dal bruciatore, accendendo un allarme acustico e una luce di avvertimento.

- Alcuni blocchi sono normali durante il primo avvio (fino a 4 circa); per sbloccare premere il tasto sull'apparecchiatura (che si trova nella parte anteriore del pannello di controllo del bruciatore) per ripetere il ciclo di avvio. Se dovesse persistere cercate l'aiuto di un tecnico specializzato.

N.B. La posizione dell'apparecchiatura al momento del blocco fornisce un'indicazione della cause di questo blocco.

REGOLAZIONE DELLA PRESSIONE DEL RITORNO DI OLIO

Il diagramma illustra il sistema di regolazione del ritorno di olio per questi tipi di bruciatori i quali hanno incorporato un ugello con ritorno variabile progressivo. La portata del olio combustibile può essere variata attraverso l'ugello di ritorno cambiando la pressione nel ritorno. La portata massima di olio combustibile si ottiene quando la pressione della pompa è di circa 30 bar e il ritorno è completamente chiuso. La portata minima del olio combustibile si ottiene quando la linea di ritorno è completamente aperta (vedi diagramma BERGONZO). La pressione in mandata si legge montando un manometro sulla pompa. La pressione del ritorno si legge sul manometro montato a corredo del bruciatore sul regolatore di pressione.

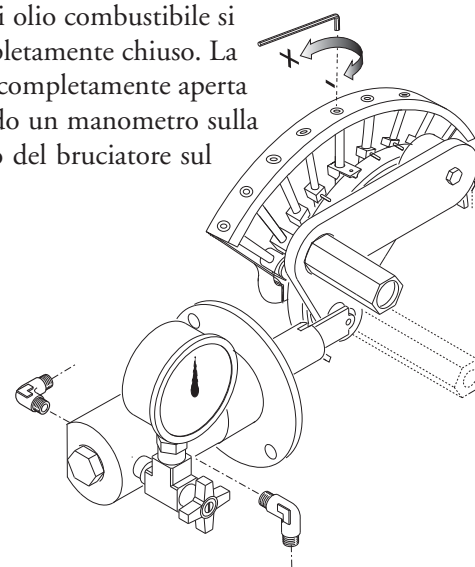

Pressione pompa 22-30 bar.

Max portata bruciatore, pressione di ritorno:

FLUIDICS ugello : 16 ÷ 19 bar.

BERGONZO ugello : 20 ÷ 24 bar.

Min portata bruciatore, pressione di ritorno:

FLUIDICS ugello : 6 ÷ 9 bar

BERGONZO ugello : 4 ÷ 8 bar

FASE DI PRELAVAGGIO

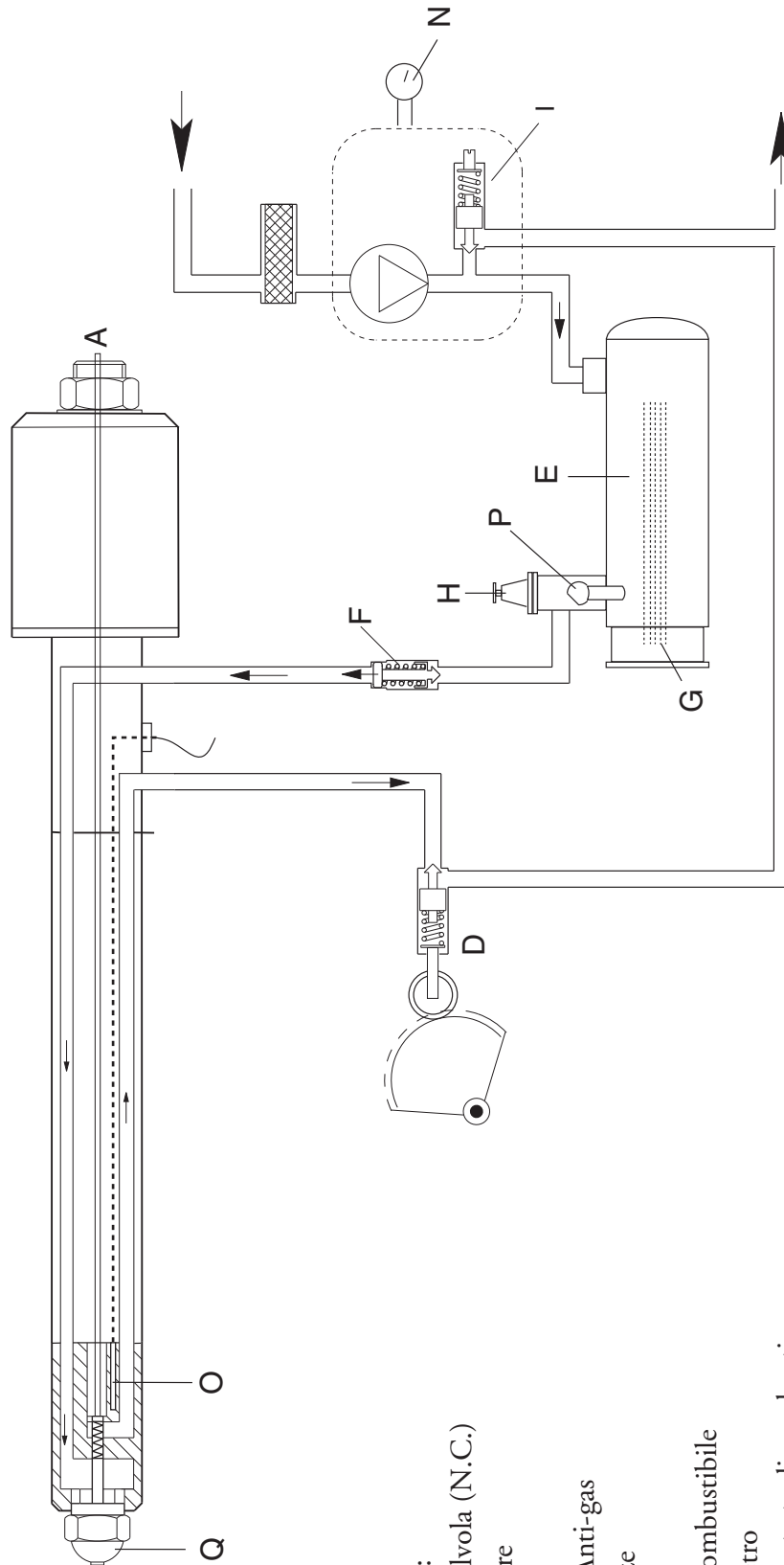

LEGENDA :

- A Elettrovalvola (N.C.)
- D Regolatore
- E Barilotto
- F Valvola Anti-gas
- G Resistenze
- H Filtro
- I Pompa combustibile
- N Manometro
- O Resistenze testa di combustione
- P Sonda temperatura
- Q Ugello

FASE DI PRELAVAGGIO

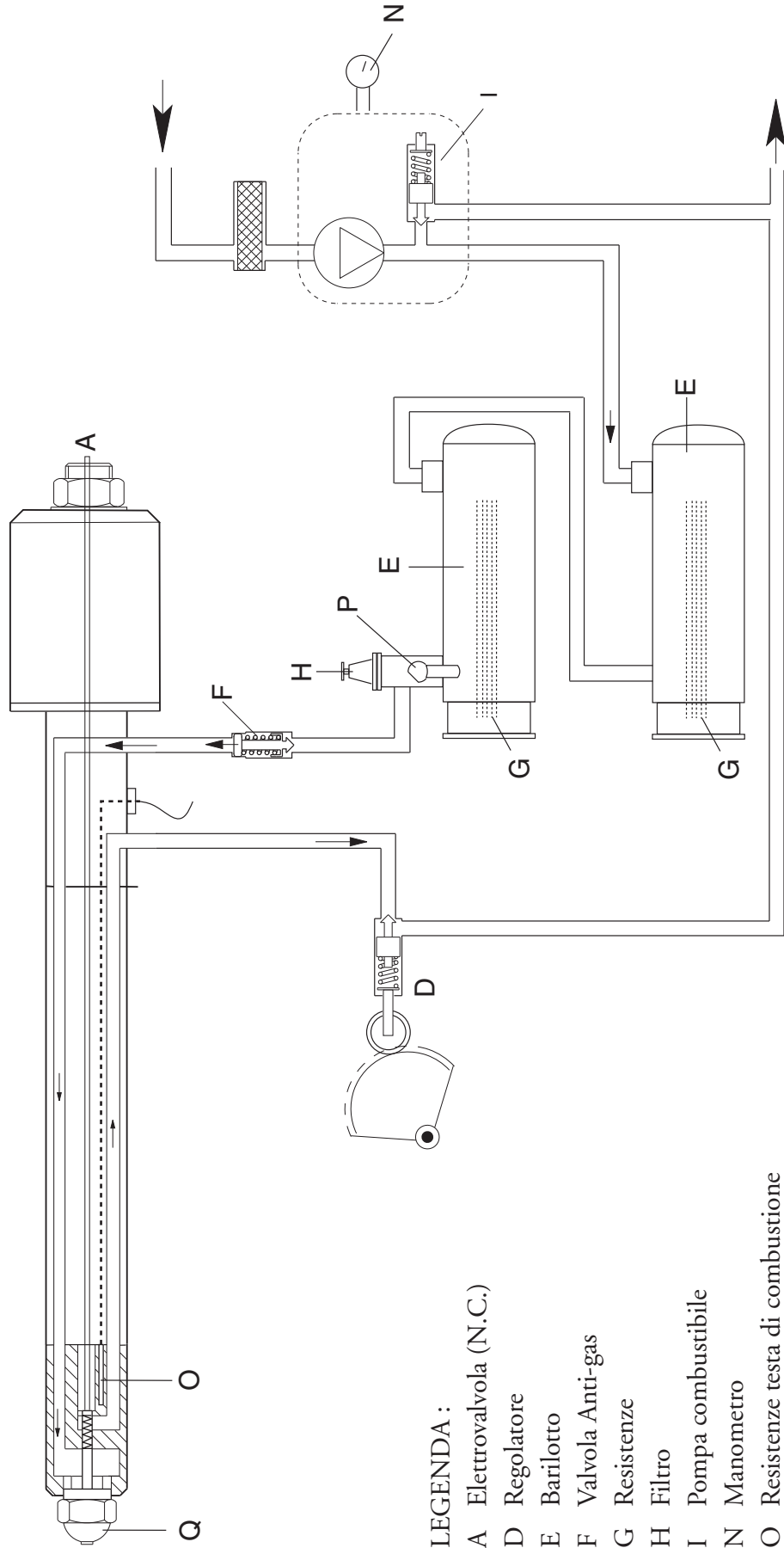

LEGENDA :

- A Elettrovalvola (N.C.)
- D Regolatore
- E Barilotto
- F Valvola Anti-gas
- G Resistenze
- H Filtro
- I Pompa combustibile
- N Manometro
- O Resistenze testa di combustione
- P Sonda temperatura
- Q Ugello

POSIZIONE DEGLI ELETTRODI

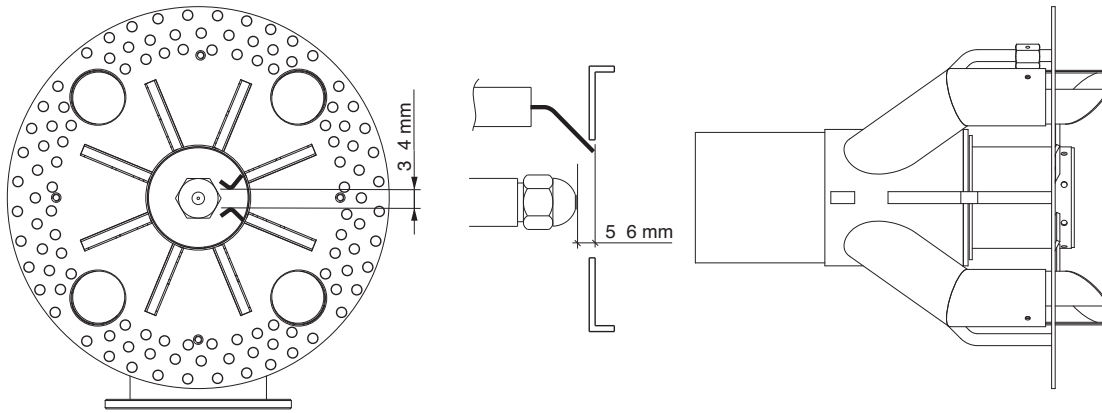

PULIZIA E SOSTITUZIONE DELL'UGELLO

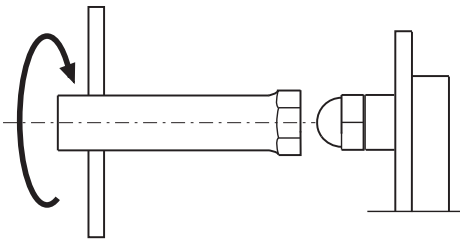

Utilizzare solo la apposita chiave fornita in dotazione pre rimuovere l'ugello, facendo attenzione a non danneggiare gli elettrodi. Montare il nuovo ugello con la medesima cura.

N.B.: Verificare sempre la posizione degli elettrodi dopo il montaggio dell'ugello (vedi figura). Una posizione errata può comportare problemi di accensione.

UGELLI FLUIDICS



TABELLA UGELLI BERGONZO
Pressione pompa (bar)

GPH	Atm	3	4	5	6	7	8	9	10	11	12	13	14	15	16	17	18	19	20	21	22	23	24	25	26	27	28	29	30
125	A	20	22	23	25	26	27	29	32	34	37	40	44	50	57	65	77	95											
125	B	20	285	280	275	274	272	271	245	235	220	205	190	175	160	145	130	115											
125	A	25	24	25	26	27	28	29	30	31	32	34	35	37	40	43	45	52	60	68	80	95	115						
125	B	25	330	328	325	320	315	307	300	285	280	275	260	250	235	220	190	180	170	168	150	135							
125	A	30	25	26	26	27	28	28	29	30	31	32	33	35	37	38	42	43	46	50	54	60	65	72	80	90	108	130	
125	B	30	370	365	360	355	350	348	345	340	335	328	320	305	300	290	280	270	260	245	240	225	210	190	180	165	150	130	
150	A	20	30	33	34	35	37	39	43	46	50	55	60	68	75	85	100	120											
150	B	20	325	320	315	308	300	290	285	275	260	250	240	220	190	180	160	140											
150	A	25	32	33	34	35	37	37	38	42	45	47	50	55	60	65	70	78	83	94	110	120	150						
150	B	25	375	370	365	363	358	355	350	345	330	320	310	300	285	275	260	250	240	220	195	180	150						
150	A	30	35	36	36	37	37	37	39	41	42	45	46	48	50	54	58	62	65	70	75	80	88	95	110	120	140	180	
150	B	30	420	420	415	410	405	400	395	390	380	375	365	350	345	340	320	300	290	280	270	250	240	220	200	180			
175	A	20	35	37	39	42	44	46	48	55	58	62	68	75	84	95	118	155											
175	B	20	350	350	349	348	330	325	315	300	290	280	265	248	225	195	175	155											
175	A	25	35	36	37	41	42	44	45	47	50	52	58	62	65	70	78	88	95	110	120	140	170						
175	B	25	395	390	385	382	380	378	370	360	350	348	330	325	315	300	280	275	260	240	225	200	170						
175	A	30	42	43	44	45	46	47	48	50	52	55	58	60	62	65	70	72	78	85	90	100	110	118	135	158	190		
175	B	30	440	440	435	430	425	420	415	410	408	400	390	380	370	360	350	330	320	300	285	275	260	250	235	220	190		
200	A	20	38	40	42	44	47	50	55	60	65	70	80	90	100	120	140	170											
200	B	20	400	398	388	380	370	360	350	340	330	320	300	280	275	250	230	210											
200	A	25	42	43	43	44	45	47	50	52	55	60	65	70	78	85	95	105	115	130	150	170	220						
200	B	25	450	448	448	445	440	430	425	412	405	400	390	380	375	360	345	325	315	290	280	260	220						
200	A	30	48	49	50	51	52	53	55	56	58	60	62	64	68	70	75	80	85	92	100	110	120	130	150	175	200		
200	B	30	500	500	495	490	485	480	475	470	460	450	440	430	420	410	395	385	375	350	340	325	315	300	290	275	260		
225	A	20	42	43	45	47	48	52	56	60	65	70	80	90	100	115	140	180											
225	B	20	420	410	405	400	395	380	375	365	350	345	335	320	300	280	265	250											
225	A	25	45	46	47	48	50	52	55	58	60	63	68	73	80	90	98	108	120	140	160	180	225						
225	B	25	475	468	460	455	450	445	437	425	410	400	380	375	360	350	340	315	300	280	260	240							
225	A	30	50	50	51	52	52	53	54	55	57	60	62	66	68	75	80	88	94	100	110	120	130	140	155	175	200	240	
225	B	30	510	510	505	503	500	495	490	480	460	460	440	430	420	410	400	390	380	370	360	350	340	325	310	300	285	275	
250	A	20	42	44	46	47	50	55	60	65	70	80	90	100	115	140	160	220											
250	B	20	425	415	408	403	400	380	375	365	350	338	325	300	280	265	250	240											
250	A	25	46	47	49	50	52	55	58	60	63	66	72	78	85	92	100	110	130	140	165	200							
250	B	25	480	475	475	470	465	450	445	440	425	410	400	380	375	355	340	310	300	280	275								
250	A	30	52	52	52	53	54	55	58	60	62	65	68	72	78	82	90	95	105	105	125	135	150	165	180	220	260		
250	B	30	520	515	515	510	510	505	500	490	480	475	460	450	440	430	420	400	380	370	360	350	340	325	310	300	285	275	
275	A	20	52	53	55	58	60	63	68	75	80	90	100	115	125	150	170	225											
275	B	20	540	530	520	510	500	490	475	450	440	420	400	375	350	325	300	275											
275	A	25	55	56	57	58	60	64	68	70	75	80	85	95	100	115	125	135	150	170	190	225	265						
275	B	25	600	600	595	590	580	570	560	550	540	525	510	500	480	460	440	425	400	375	350	325	300						
275	A	30	60	61	62	63	64	65	66	67	70	74	78	82	88	95	100	110	118	125	135	150	165	180	200	240	275		
275	B	30	680	675	668	662	658	650	640	630	620	610	600	590	580	565	555	545	525	500	480	460	440	425	400	375	350		

A= portata dell'ugello B= portata della pompa

Portata (kg/h)

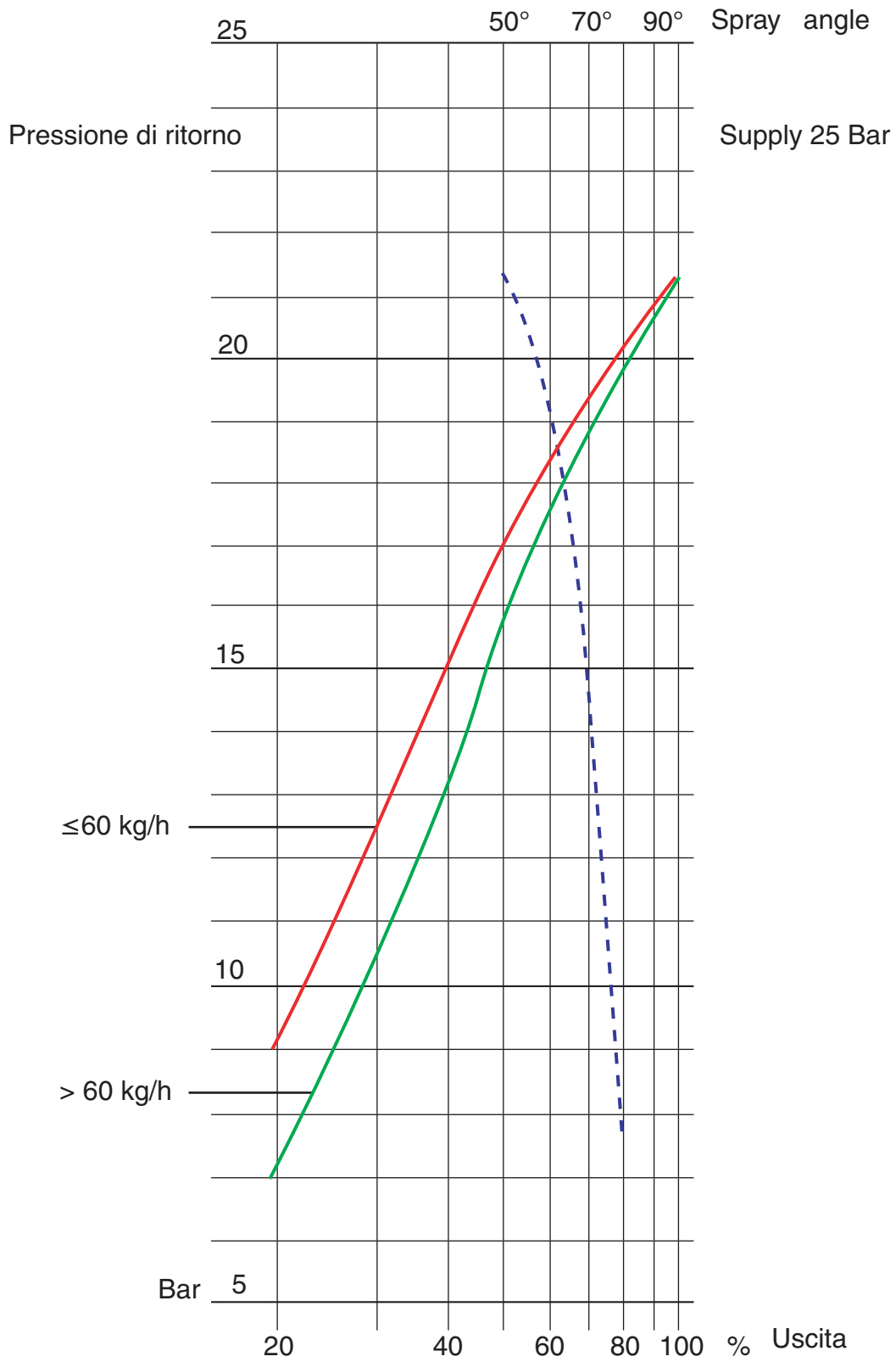
TABELLA UGELLI BERGONZO
Pressione pompa (bar)

GPH	Atm	3	4	5	6	7	8	9	10	11	12	13	14	15	16	17	18	19	20	21	22	23	24	25	26	27	28	29	30
300	A	20	55	58	60	64	65	70	76	85	92	105	118	135	145	175	200	270											
300	B	20	550	535	525	515	500	485	470	450	430	410	380	375	360	330	310	280											
300	A	25	24	25	26	27	28	29	30	31	32	34	35	37	40	43	45	52	60	68	80	95	115						
300	B	25	330	328	325	320	315	307	300	285	280	275	260	250	235	220	190	180	170	168	150	135							
300	A	30	25	26	26	27	28	28	29	30	31	32	33	35	37	38	42	43	46	50	54	60	65	72	80	90	108	130	
300	B	30	370	365	360	355	350	348	345	340	335	328	320	305	300	290	280	270	260	245	240	225	210	190	180	165	150	130	
325	A	20	58	62	65	68	72	78	88	95	110	118	135	150	170	200	240	290											
325	B	20	570	560	550	530	510	500	485	475	450	440	425	400	370	350	330	300											
325	A	25	65	67	69	72	74	75	80	85	90	98	105	115	125	140	160	170	190	225	270	320							
325	B	25	650	643	638	630	628	620	610	600	590	580	565	540	520	500	475	450	425	400	375	350							
325	A	30	68	69	70	71	73	75	78	82	88	92	98	105	110	120	130	140	150	165	180	200	225	250	280	320	360		
325	B	30	720	715	710	705	702	700	690	680	670	655	620	610	600	580	570	550	520	500	480	460	440	420	400	380			
350	A	20	64	68	70	75	80	90	98	105	118	130	145	160	180	210	250	310											
350	B	20	620	600	590	580	570	550	530	500	480	460	440	420	400	375	360	340											
350	A	25	68	69	70	75	80	85	90	98	105	112	120	130	145	160	170	190	210	240	270	300	350						
350	B	25	700	700	690	680	670	660	650	630	610	590	580	550	520	500	480	465	450	430	410	380	360						
350	A	30	68	69	70	73	78	82	88	92	98	105	110	120	128	138	145	160	170	190	210	225	250	275	300	350	375		
350	B	30	790	780	770	760	750	740	720	710	700	690	680	665	650	625	610	590	570	550	520	505	490	475	440	425	400		
375	A	20	72	76	82	88	94	105	115	125	140	155	170	195	225	250	300												
375	B	20	630	615	600	590	580	565	550	520	490	475	450	425	400	375	360												
375	A	25	78	80	85	90	95	100	105	110	120	130	140	155	170	190	200	230	250	280	325	375							
375	B	25	700	690	680	670	660	650	640	625	615	600	580	565	550	520	500	480	460	440	420	400							
375	A	30	90	92	93	95	98	100	105	110	115	120	130	140	150	160	170	180	200	220	240	260	280	320	350	400			
375	B	30	800	790	786	778	770	760	750	730	710	700	690	670	650	630	610	600	590	570	550	530	510	490	470	440			
400	A	20	85	90	98	105	115	125	135	150	165	185	210	240	270	320													
400	B	20	610	605	595	585	575	565	550	520	500	480	460	440	420	400													
400	A	25	85	90	98	104	110	118	125	135	145	155	170	190	200	225	250	280	310	360	400								
400	B	25	710	705	700	695	690	680	670	650	630	610	590	580	560	540	520	500	480	450	425								
400	A	30	100	102	106	110	114	117	120	130	138	148	158	170	180	195	210	230	250	275	300	340	360	400	440				
400	B	30	800	790	786	778	770	760	750	730	710	700	690	670	650	630	610	600	590	570	550	530	510	490	470				
425	A	20	78	80	85	90	95	100	110	120	135	150	170	190	220	250	300	350											
425	B	20	700	690	680	670	650	630	615	600	590	570	530	510	490	450	410	380											
425	A	25	85	88	90	93	95	100	105	110	120	130	140	150	165	180	195	225	250	280	325	380							
425	B	25	750	745	740	730	720	710	700	685	675	665	650	630	610	600	580	560	540	515	490	430							
425	A	30	91	92	94	96	98	99	100	104	110	118	128	138	145	158	168	180	195	210	235	260	280	320	350	400	450		
425	B	30	820	816	812	808	804	800	780	770	760	750	740	730	720	710	695	680	650	625	600	590	570	540	515	490			
450	A	20	86	90	94	98	105	115	125	135	150	170	195	225	250	280	340	380											
450	B	20	700	685	660	645	635	620	605	585	570	545	530	515	490	470	440	410											
450	A	25	92	95	100	105	110	115	120	130	140	150	165	175	190	210	230	260	280	325	375	425							
450	B	25	805	800	790	775	760	745	730	715	700	690	670	650	625	605	580	560	540	520	500	480							
450	A	30	100	102	105	108	111	114	117	120	130	140	150	160	170	180	190	220	240	260	280	310	350	380	425	475			
450	B	30	860	856	850	842	834	826	818	810	790	760	750	740	730	720	700	680	660	640	620	600	580	540	520	500			

A= portata dell'ugello B= portata della pompa

Portata (kg/h)

TABELLA UGELLI BERGONZO
Pressione pompa (bar)

GPH	Atm	3	4	5	6	7	8	9	10	11	12	13	14	15	16	17	18	19	20	21	22	23	24	25	26	27	28	29	30			
475	A	82	88	95	100	110	120	130	145	160	170	195	225	260	300	360																
475	B	800	780	760	740	720	700	680	655	625	600	580	560	520	480	440																
475	A	98	102	108	112	116	120	130	140	150	160	170	180	195	225	250	275	300	350	400	475											
475	B	910	905	900	880	860	840	820	800	780	750	730	710	690	670	650	620	590	560	530	500											
475	A	30	104	107	110	113	117	120	125	135	145	155	163	170	180	190	200	225	250	275	300	325	360	390	440	480						
475	B	1000	990	975	965	945	930	915	900	890	880	860	840	820	800	780	760	730	700	680	660	640	620	590	460							
500	A	20	94	102	106	113	120	130	150	170	190	210	230	250	280	325	380															
500	B	800	780	760	740	720	710	680	660	640	610	580	560	520	500	475																
500	A	25	100	104	108	116	120	130	140	150	160	170	190	210	230	250	270	325	350	400	475											
500	B	900	895	880	865	850	845	830	815	800	780	750	720	700	670	650	620	600	580	550												
500	A	30	110	113	117	120	125	130	135	140	150	160	170	180	190	220	250	280	250	300	325	350	380	425	480	520						
500	B	1000	990	980	970	960	950	940	925	910	900	880	860	840	820	800	775	750	725	700	680	660	640	620	590	460						

Portata (kg/h)

A= portata dell'ugello B= portata della pompa

MANUTENZIONE

CONTROLLO ANNUALE

Il controllo periodico del bruciatore (testa di combustione, elettrodi, ecc.) deve essere effettuato da personale autorizzato una o due volte all'anno a secondo dell'utilizzo.

Prima di procedere al controllo per la manutenzione del bruciatore è consigliabile verificare lo stato generale del bruciatore e seguire le seguenti operazioni :

- Togliere tensione al bruciatore (togliere la spina). - Chiudere il rubinetto di intercettazione gas. - Togliere il coperchio del bruciatore, pulire la ventola e l'aspirazione dell'aria. - Pulire la testa di combustione e controllare la posizione degli elettrodi. - Rimontare i pezzi. - Verificare la tenuta dei raccordi gas. - Verificare il camino. - Far ripartire il bruciatore.
- Controllare i parametri della combustione ($CO_2 = 9,5 \div 9,8$), ($O =$ inferiore a 75 ppm).

PRIMA DI OGNI INTERVENTO CONTROLLARE :

- Che ci sia corrente elettrica nell'impianto e il bruciatore collegato.
- Che la pressione del gas sia corretta e il rubinetto di intercettazione del gas aperto.
- Che i sistemi di controllo siano regolarmente collegati.

Se tutte queste condizioni sono soddisfatte , far partire il bruciatore premendo il pulsante di sblocco. Controllare il ciclo del bruciatore.

IL BRUCIATORE NON SI AVVIA :

- Controllare l'interruttore, i termostati, il motore, pressione gas.
- Interruttore generale in posizione "0".
- Fusibili saltati.
- Apparecchiatura di controllo difettosa.

IL BRUCIATORE EFFETTUA LA PREVENTILAZIONE E AL TERMINE DEL CICLO VA IN BLOCCO :

- Controllare la pressione dell'aria e la ventola.
- Controllare il pressostato aria.
- Apparecchiatura di controllo difettosa.
- Trasformatore difettoso.
- Verificare il cavo di accensione.
- Elettrodi sporchi, difettosi o in posizione errata.
- Ugelli otturati o usurati.
- Filtri intasati.
- Pressione olio combustibile troppo bassa.
- Portata d'aria di combustione eccessivamente elevata in rapporto alla portata dell'ugello.

IL BRUCIATORE EFFETTUA LA PREVENTILAZIONE E NON ACCENDE :

- Verificare il montaggio e la posizione degli elettrodi.
- Verificare il cavo di accensione.
- Verificare il trasformatore di accensione.
- Verificare l'apparecchiatura di sicurezza.

IL BRUCIATORE SI ACCENDE E DOPO IL TEMPO DI SICUREZZA VA IN BLOCCO :

- Controllare fase e neutro che siano collegati correttamente.
- Controllare l'elettrovalvole del gas.
- Controllare la posizione della fotocellula e la sua connessione.
- Controllare l'apparecchiatura di sicurezza.
- Ugelli otturati o usurati.
- La fotocellula non vede la fiamma.
- Filtri intasati.
- Pressione olio combustibile troppo bassa.
- Portata d'aria di combustione eccessivamente elevata in rapporto alla portata dell'ugello.

IL BRUCIATORE SI ACCENDE E DOPO QUALCHE MINUTO DI FUNZIONAMENTO VA IN BLOCCO :

- Controllare il regolatore di pressione e il filtro gas.
- Controllare la pressione del gas con un manometro.
- Controllare il valore di rivelazione (min. 70 μA).

IL BRUCIATORE NON PASSA IN ALTA FIAMMA :

- Selettore di Alta e Bassa fiamma sulla morsettiera in posizione errata.
- Apparecchiatura di controllo difettosa.
- Bobina dell'elettrovalvola difettosa.
- Pressione olio combustibile troppo bassa.
- Filtri intasati.
- Ugello otturato o usurato.
- Motoriduttore comando serranda aria non tarato o difettoso.

Index

1 - Technical data

- Technical datap.20
- Overall dimensionsp.20

2 - Installation

- Electrical connectionsp.21
- Gas connectionp.21

3 - Gas starter and regulations

- Working of the burnerp.21
- Adjusting combustion processp.21
- Control box up-cyclep.22
- Adjusting air/gasp.22,23
- Adjusting combustion head/pressure switchp.24
- Detector currentp.24
- Removing firing headp.25

4 - Heavy oil starter and regulations

- Oil connection burnerp.25
- Verificationsp.25
- Working of the burnerp.26
- Regulationsp.26
- Hydraulic systemp.27,28
- Position of ignition electrodes and cleaningp.29
- Table nozzlesp.30,31,32,33,34

5 - Maintenance

- Maintenancep.35

TECHNICAL DATA

MODEL		Multiflam 700.1	Multiflam 800.1	Multiflam 1000.1	Multiflam 1200.1
Thermal power max.	kW	7.500	8.500	10.500	13.000
	kcal/h	6.465.000	7.327.500	9.052.000	11.207.000
Thermal power min.	kW	1.500	2.000	2.500	2.700
	kcal/h	1.290.000	1.724.000	2.155.000	2.327.600
Natural gas pressure	mbar	60÷700	85÷700	115÷700	160÷700
LPG pressure	mbar	125÷700	185÷700	110÷700	160÷700
Voltage 50 Hz	V	230/400	230/400	230/400	230/400
Fuel :	Natural Gas (L.C.V. 8.570 kcal/Nm ³), LPG (L.C.V. 22.260 kcal/Nm ³) Heavy oil (L.C.V. 9.800 kcal/kg max. visc 50°E at 50°C)				

OVERALL DIMENSIONS

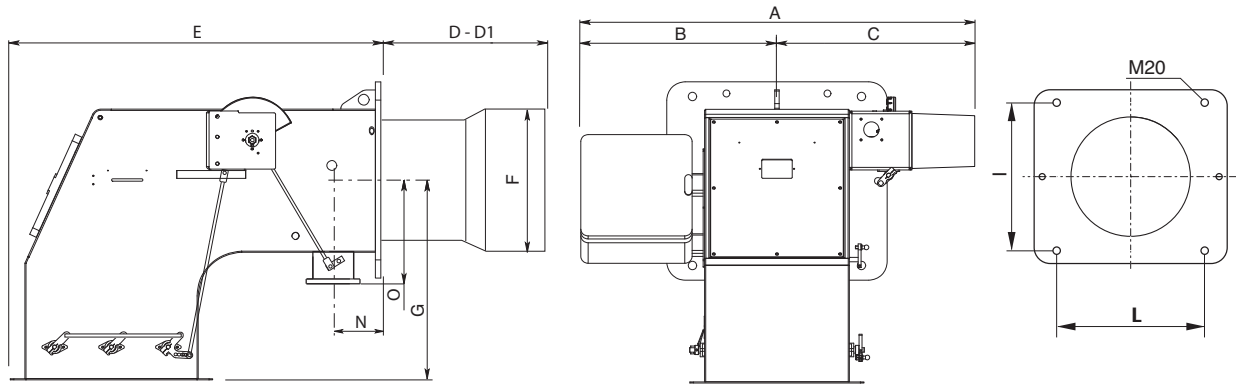

D = Short head D1= Long head Dimensions (mm)

MODEL	A	B	C	D	D1	E	F	G	I	L	M	N	O
Multiflam 700.1 TS	1170	540	630	470	-	1030	420	550	460	460	M20	195	232
Multiflam 800.1 TS	1170	540	630	470	-	1030	420	550	460	460	M20	195	232
Multiflam 1000.1 TS	1170	540	630	470	-	1030	420	550	460	460	M20	195	232
Multiflam 1200.1 TS	1170	540	630	470	-	1030	450	550	460	460	M20	195	232

AIR FLANGE

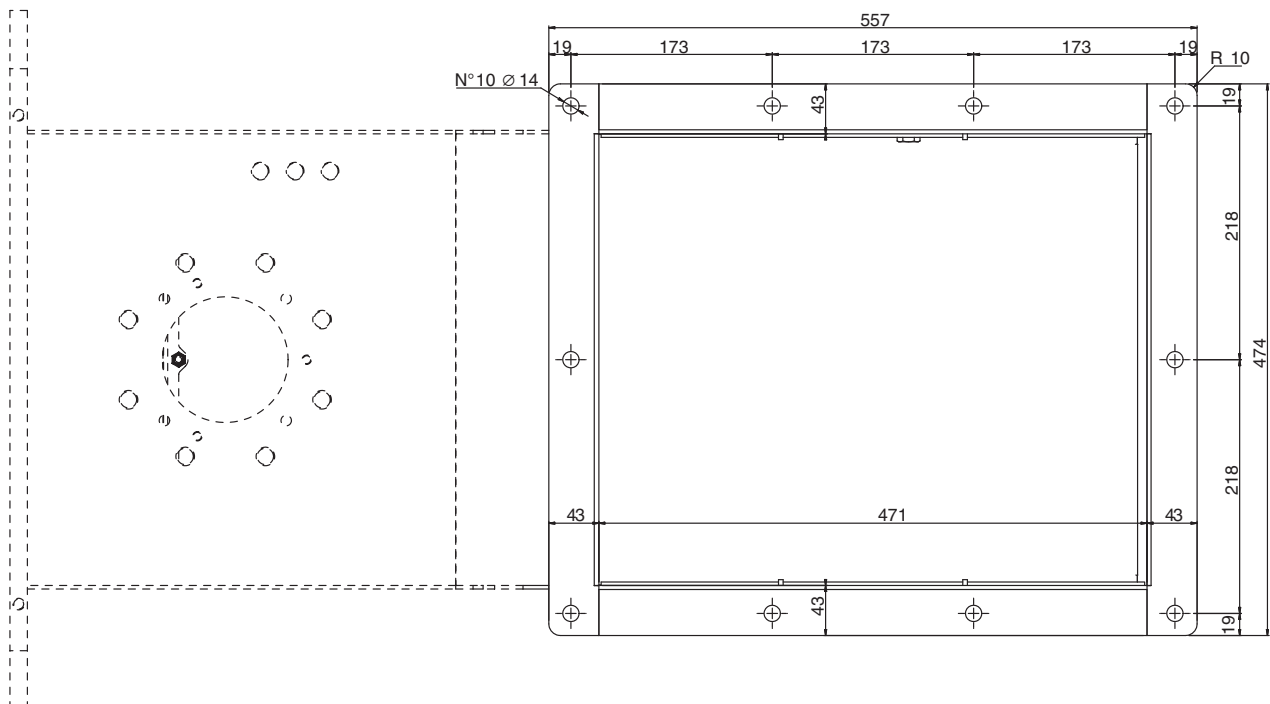

ELECTRICAL CONNECTIONS

All burners factory tested at 400 V 50 Hz three-phase for motors and 230 V 50 Hz monophas with neutral for auxiliary equipment. If mains supply is 230 V 50 Hz threephase withuot neutral, change position of connectors on burner as in fig. Protect burner supply line with safety fuses and any other devices required by safety standards obtaining in the country in question.

CONNECTION TO THE GAS PIPELINE

Once connected the burner to the gas pipeline, it is necessary to control that this last is perfectly sealed. Also verify that the chimney is not obstructed. Open the gas cock and carefully bleed the piping through the pressure gauge connector, then check the pressure value trough a suitable gauge. Power on the system and adjust the thermostats to the desired temperature. When thermostats close, the sealing control device runs a seal test of valves; at the end of the test the burner will be enabled to run the start-up sequence.

OPERATION OF BURNER WITH GAS

Before starting the burner, make sure it is mounted correctly. Then check connections are correct according to the diagram and piping is appropriate to the system. Before connecting the burner to the electricity supply, make sure voltage corresponds to burner plate data. The connection diagram and start-up cycle are shown separately. For wiring from control box to burner, see the enclosed connection diagram. Pay particular attention to neutral and phase connections : never exchange them!. Vent air and impurities of gas pipe. Check gas pressure conforms to the limits stated on the burner plate when connecting a master gauge to the test port provided on the burner. Blower motor starts and pre-purging begins. Since pre-purging has to be carried out with the max. air delivery, the burner control circuit turns the air damper to the max. delivery position by the air servocontrol in approximately 30 seconds time. When the servocontrol is fully open, a signal to the electronic control unit starts the 66 seconds (36 s. LFL 1.333) seconds pre-purge cycle. At the end of the prepurging time, the air servocontrol gets to the Low Flame position so that burner ignition is ensured at min. output. Simultaneously the ignition transformer receives voltage and after 3 seconds (pre-ignition) opens the pilot gas valve. Fuel flows to the combustion head and ignites. Two seconds after pilot gas valves have opened, the ignition transformer is excluded from the circuit. In case of no ignition the burner goes to lock-out within two seconds. After 6 sec. open the working gas valve, governed by the gas firing butterfly valve. Now the burner is operating at the min. firing rate (about 30% of the max. firing rate). The air servocontrol runs at the Low Flame position and in case the temperature control has to be set at the max. output it goes to a fully open position of air damper and butterfly valve. During the burner-off periods the air damper closes up fully.

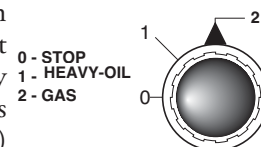

ADJUSTING THE COMBUSTION PROCESS

IMPORTANT: to obtain the right adjustment of the combustion and thermal capacity it is important to analyze the reducts of combustion with the aid of suitable instruments. The combustion and thermal capacity adjustment is done simultaneously, together with the analysis of the products of combustion, making sure that the measured values are suitable and that they comply with current safety standards. On this matter, please refer to the table and figure below.

THESE OPERATIONS MUST BE DONE BY PROFESSIONALLY-QUALIFIED TECHNICIANS.

LANDIS & STAEFA, Model LFL1.622 - LFL1.333 OPERATING CYCLE

Ref.	Description	Duration
t1	Duration Waiting time for confirmation of air pressure	8"
t2	Preventilation time	66"(36")
t3	Safety time	2"
t4	Pressurizing time	4"
t5	Time for enabling operation of the main gas valve on minimum capacity	10"
t6	Time for enabling operation of the main gas valve on maximum capacity	10"

The control box starts the burner fan, to carry out the prepurging of the combustion chamber, and checks the vent air pressure through the air pressure switch. At the end of prepurging, the ignition transformer cuts-in and generates a spark between the electrodes. At the same time the two gas valves open (Vs safety valve and VI working valve). The total safety, in case of missed ignition or casual burner's flame-out, is granted by a ionisation probe which cuts-in and sets the burner shutdown within the safety time. In case of gas lack or a major pressure drop, the minimum air pressure switch shuts down the burner.

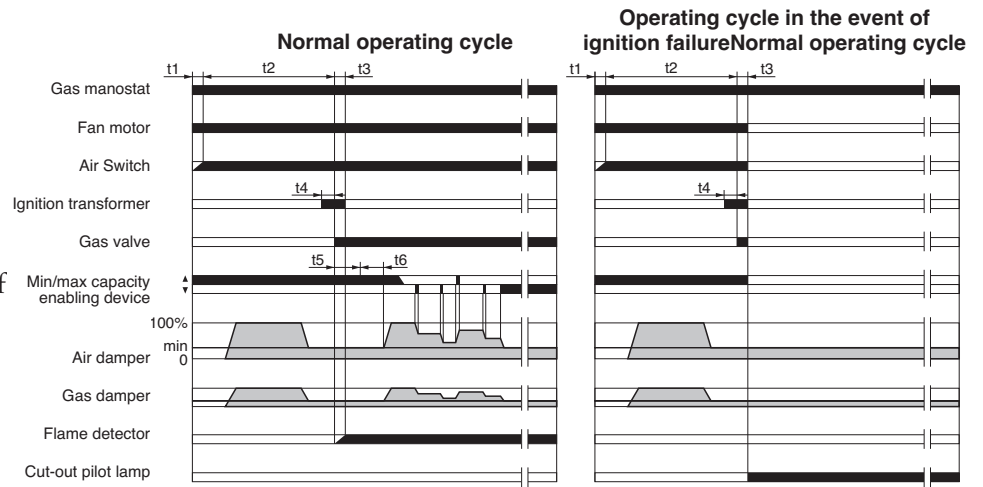

LANDIS & STAEFA SQM 50.481A2 AIR DAMPER MOTOR

Remove cover to gain access to the adjusting cams. The cams are to be adjusted through the suitable key provided for. Description:



Multiflam 700.1-1200.1 PR/PR

- I - High flame operating opening position adjusting cam (Heavy-Oil /Gas).
- II - Limit switch for the air damper position at burner's shut down.
- III - Ignition flame opening position adjusting cam (Gas).
- IV - Ignition flame opening position adjusting cam(Heavy-Oil).
- V - Low flame operating opening position adjusting cam (Gas).
- VI - Low flame operating opening position adjusting cam (Heavy-Oil).
- VII - High flame operating opening position adjusting cam (Gas).
- VIII - Not used cam.

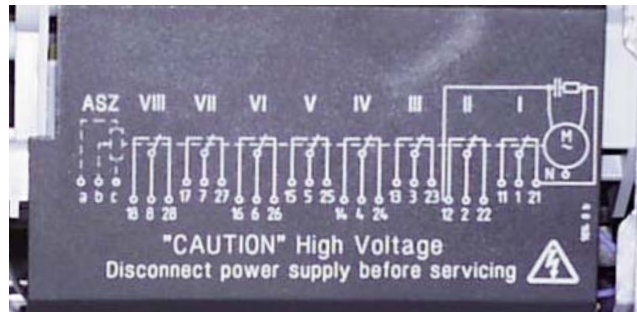

CALCULATING THE BURNER CAPACITY

To calculate the burner's capacity in kW, proceed as follows: Check the gas flow rate (in liters) on the counter and the time of the reading in seconds.

Proceed with the calculation using the following : $\frac{e}{sec} \times f = kW$

e = Litres gas
 sec = Time in second
 f $\left\{ \begin{array}{l} G20 = 34,02 \\ G30 = 116 \\ G31 = 88 \end{array} \right.$

AIR ADJUSTMENT

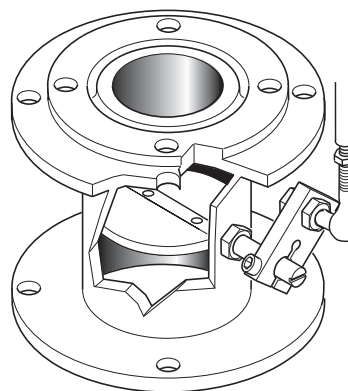
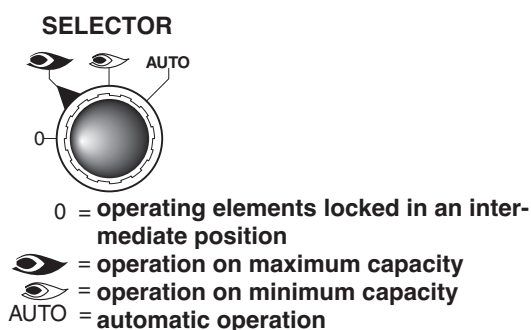
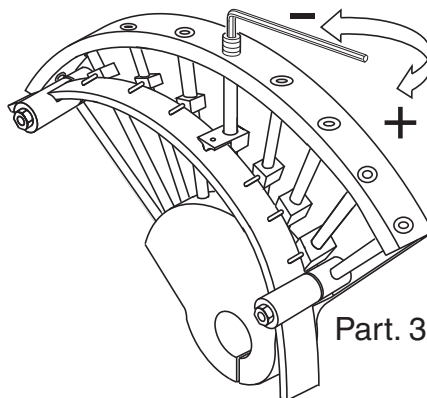
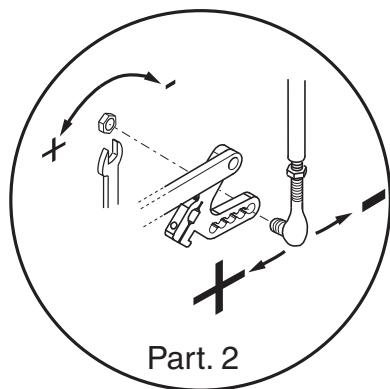

ADJUSTING THE MINIMUM CAPACITY OF THE BURNER – AIR and GAS

Position the selector placed on the control panel on position 2 and proceed as follows:
Adjust the minimum gas flow rate using a suitable wrench, turn the butterfly valve until you reach the correct gas flow, as established by analyzing the combustion process.

ADJUSTING THE MAXIMUM CAPACITY OF THE GAS

Position the selector, situated on the control panel, on position 1 and proceed as follows:
Adjusting the maximum gas flow rate (see figure on solenoid valve adjustments) or adjust the gas pressure in the governor.

ADJUSTING THE MAXIMUM AIR FLOW RATE

Adjusting the maximum air flow rate (see figure, detail 2). Loosen the nut holding the air damper transmission rod;
The correct air flow as established by analyzing the combustion process.

ADJUSTING THE INTERMEDIATE BURNER CAPACITY

Using the selector, start the servomotor (closing or opening) and position on 0 to stop the stroke; the adjustment is made as outlined below. Repeat the operation for the other cam points.
Adjustment the intermediate gas flow rates (see figure, detail 3): - using a suitable Allen wrench, change the position of the cam guide blade; if you screw it down, the flow rate is reduced; if you unscrew it, the flow rate increases.

COMBUSTION ADJUSTMENT

WARNING: In order to have a correct combustion and thermal output adjustments, these must be carried out together with a combustion analysis, to be executed through suitable devices, taking care that the values are the correct ones and are in accordance with the local safety regulations. The adjustments must be carried out by qualified and skilled technicians authorised by Ecoflam Bruciatori S.p.A.

FIRING HEAD SETTING

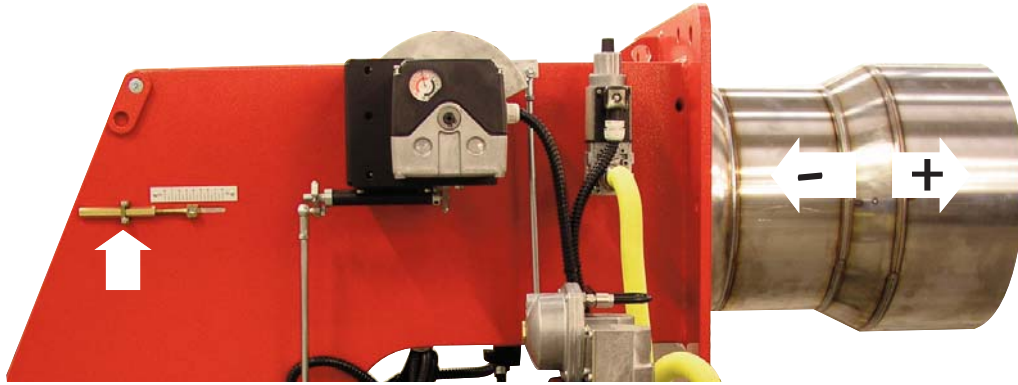

ADJUSTMENT OF GAS MINIMUM PRESSURE SWITCH

Unscrew off and remove cover M. - Set regulator N to a value equal to 60% of gas nominal feed pressure (i.e. for nat. gas nom. pressure = 20 mbar, set regulator to a value of 12 mbar; for L.P.G. nom. pressure of G30/G31- 30/37 mbar, set regulator to a value of 18 mbar). Screw up cover M

ADJUSTMENT OF THE AIR PRESSURE SWITCH

Unscrew screws A and B and remove cover C.- Set the pressure switch to the minimum by turning regulator D to position 1.

- Start the burner and keep in low flame running, while checking that combustion is correct. Through a small cardboard, progressively obstruct the air intake until to obtain a CO₂ increase of 0,5±0,8% or else, if a pressure gauge is available, connected to pressure port E, until reaching a pressure drop of 1 mbar (10 mm of W.G.). - Slowly increase the adjustment value of the air pressure switch until to have the burner lockout. Remove the obstruction from the air intake, screw on the cover C and start the burner by pressing the control box rearm button.

Note: The pressure measured at pressure port E must be within the limits of the pressure switch working range. If not, loose the locking nut of screw F and gradually turn the same: clockwise to reduce the pressure; counterclockwise to increase. At the end tighten the locking nut.

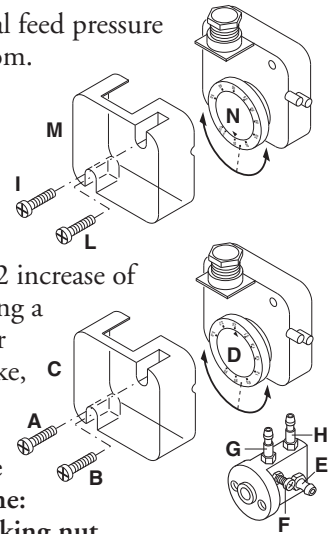

DETECTOR CURRENT

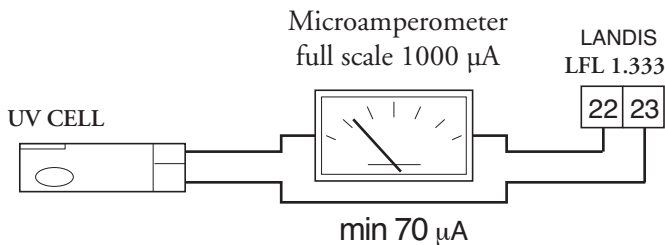

The detector current is checked by inserting a microammeter (scale 1000 µA - d.c.) in series with the uv cell.. The flame detector current has to been > 70 µA.

REMOVING THE BLAST TUBE

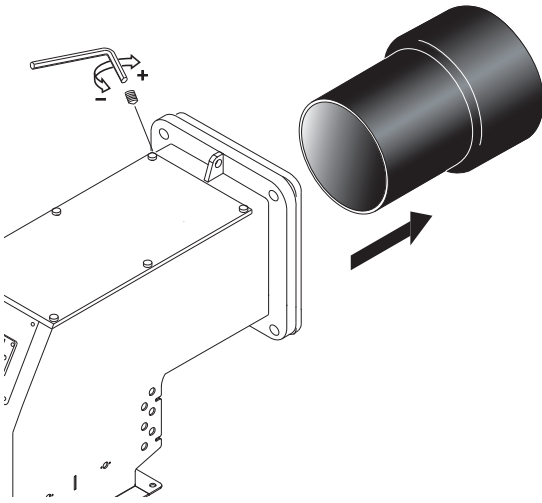

FIRING HEAD DISASSEMBLY

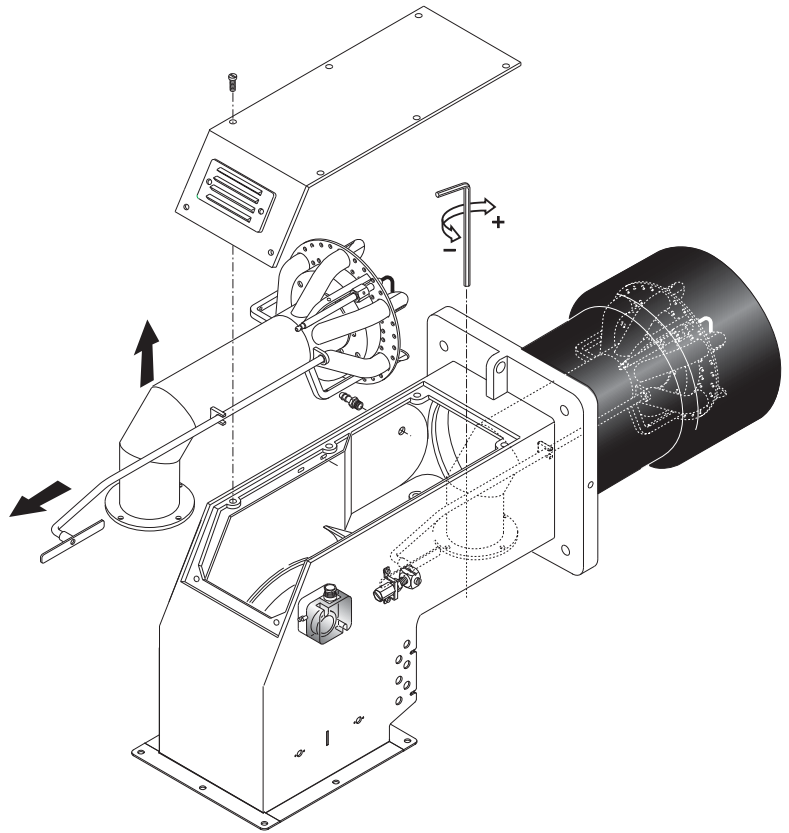

OIL CONNECTION BURNER

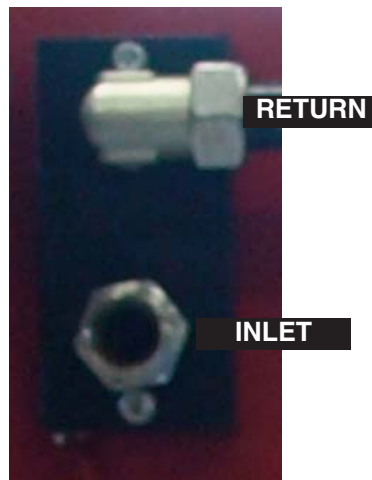

CHECKS TO BE MADE TO ENSURE A PROPER INSTALLATION:

Before proceeding with the filling of the fuel system and subsequent burner start up, it is advisable to carry out the following checks:

- Power line must be adequate to system's adsorbed load
- Fuses must be adequate to the system's load
- Boiler's thermostats must have been properly connected
- Voltage and frequency must be within the specified limits
- Fuel type must be the one specified by the burner manufacturer
- Feed piping section must be adequate to the requested fuel flow rate
- Filters, cocks as well as fittings must have been properly installed
- Blast tube length must be the one specified by the boiler manufacturer
- Nozzle's flow rate of the burner must be adequate to boiler's output

MODULATING OPERATION

With the burner in the start position and the appliance thermostats enabled, power is delivered to the resistances (G) of the preheater and heating cartridges for the pumps and the fuel supply line to the head (O).

When the preheater thermostat reaches the set value, (usually a minimum of about 90°C is necessary to guarantee a good level of circulation) the pump start-up is enabled (set point on out 1, if using the GEFRAN 200 thermoregulating device). If the preheating system of the tank is also equipped for a fluid exchanger (hot water, steam, diathermic oil) the thermostat may enable a contact in the terminal block for any stop-start of the fluid electrovalve. This is not a standard solution as the heated fluid is normally always connected. The pump starts to send oil (the head has already been heated by its cartridge (O) and therefore has no residue of cold dense oil) which flows from the tank to the head and then to the return line of the ring. When the head thermostat reaches the set value (usually about 70-30°C the cycle starts properly and the control programmer enables start-up. The servomotor sets itself at minimum (see chapter on regulation) acting on the air and fuel via the pressure regulator on the return.

The electromagnet (A) opens the nozzle (Q) in the following condition :

- sparks from the ignition electrodes are generated by the transformer also governed by the burner control device.

If the cell fails to detect the flame the burner shuts down (with the cyclic control programmer cutting in).

Once ignition has taken place and after the flame stabilisation period, the system starts operating in modulating mode.

- Before start-up make sure that the pump and delivery pipes are completely filled with hot fuel oil; the absence of fuel oil can cause pump seizure.
- If there is a block, a specific warning light on the programmer and on the burner front control board lights up and this signal is usually sent to the main control board of the equipment using the burner, setting off a buzzer and warning light.
- A few blocks are normal on first starting up (up to about 4); to release press the button on the programmer (also found on the front of the burner control board) for repeating the start cycle. Should they continue to occur seek the help of a specialised technician.

N.B. The position of the programmer at the time of the block is memorised to supply an indication of the cause of this block.

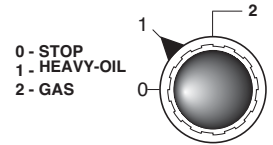

OIL DELIVERY ADJUSTMENT

The diagram illustrates the fuel feeding system of these types of burners, which incorporates a by-pass nozzle with oil flow regulation on its return pipe. The oil supply is varied by acting on the nozzle through the pressure in the return line. Max. oil supply is therefore reached when the pressure in the pump line is about 30 bar and the return line is fully closed; min. oil supply when the return line is fully open. Relevant pressure readings in the return line are as follows:

Pump pressure 22-30 bar.

Max Burner output, return oil pressure :

FLUIDICS nozzle : 16 ÷ 19 bar.

BERGONZO nozzle : 20 ÷ 24 bar.

Min Burner output, return oil pressure :

FLUIDICS nozzle : 6 ÷ 9 bar

BERGONZO nozzle : 4 ÷ 8 bar

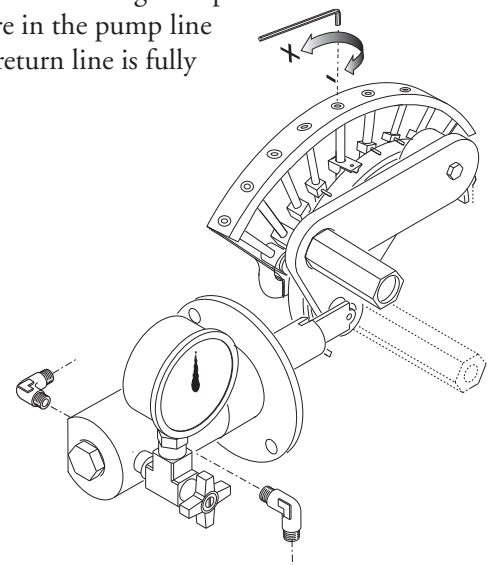

PRE - PURGING PHASE

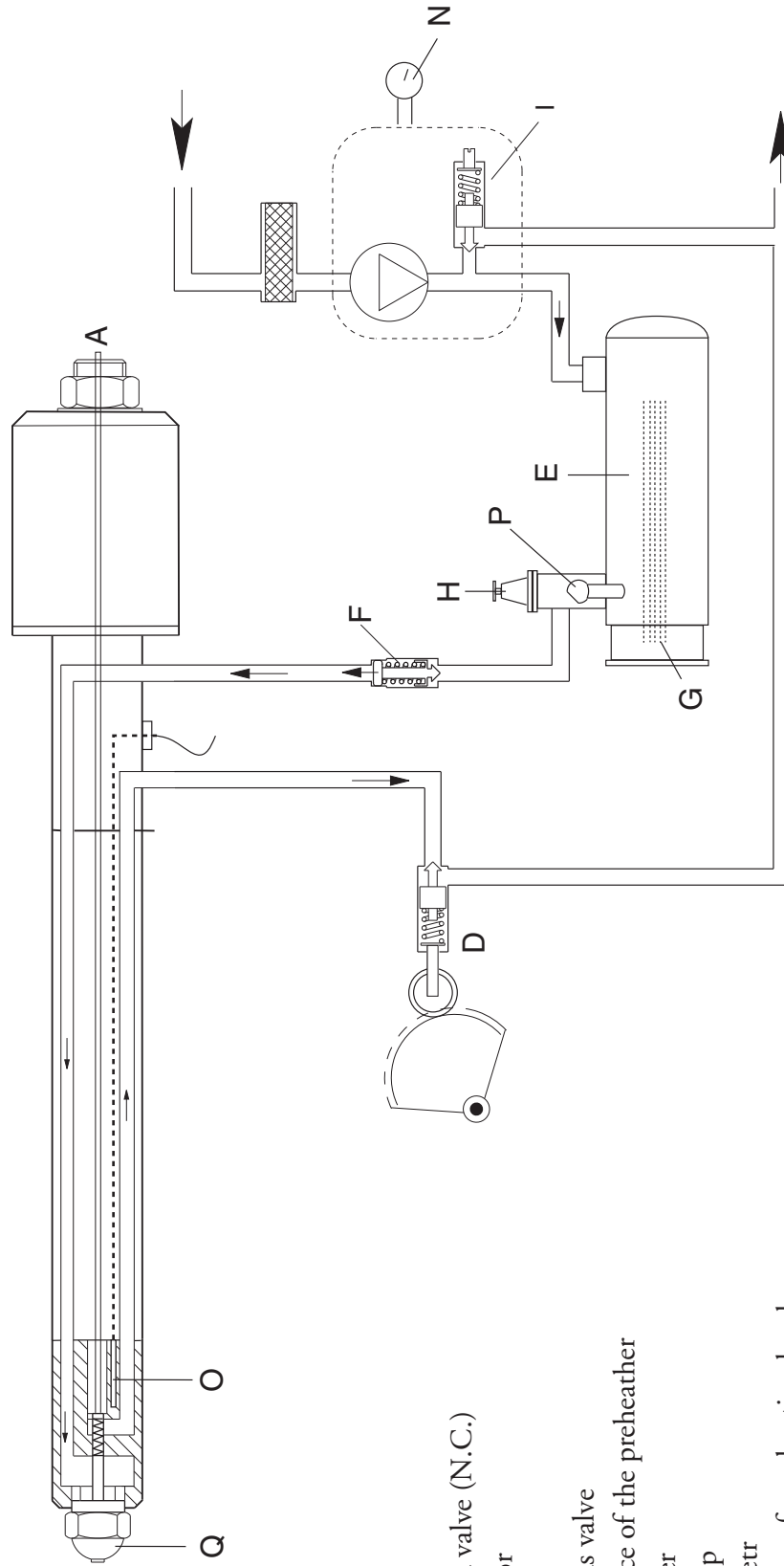

- LEGEND :
- A Solenoid valve (N.C.)
 - D Regulator
 - E Tank
 - F Anti - gas valve
 - G Resistance of the preheater
 - H Pipe filter
 - I Oil pump
 - N Manometr
 - O Resistance of combustion head
 - P Oil temperature sensor
 - Q Oil nozzle

PRE - PURGING PHASE

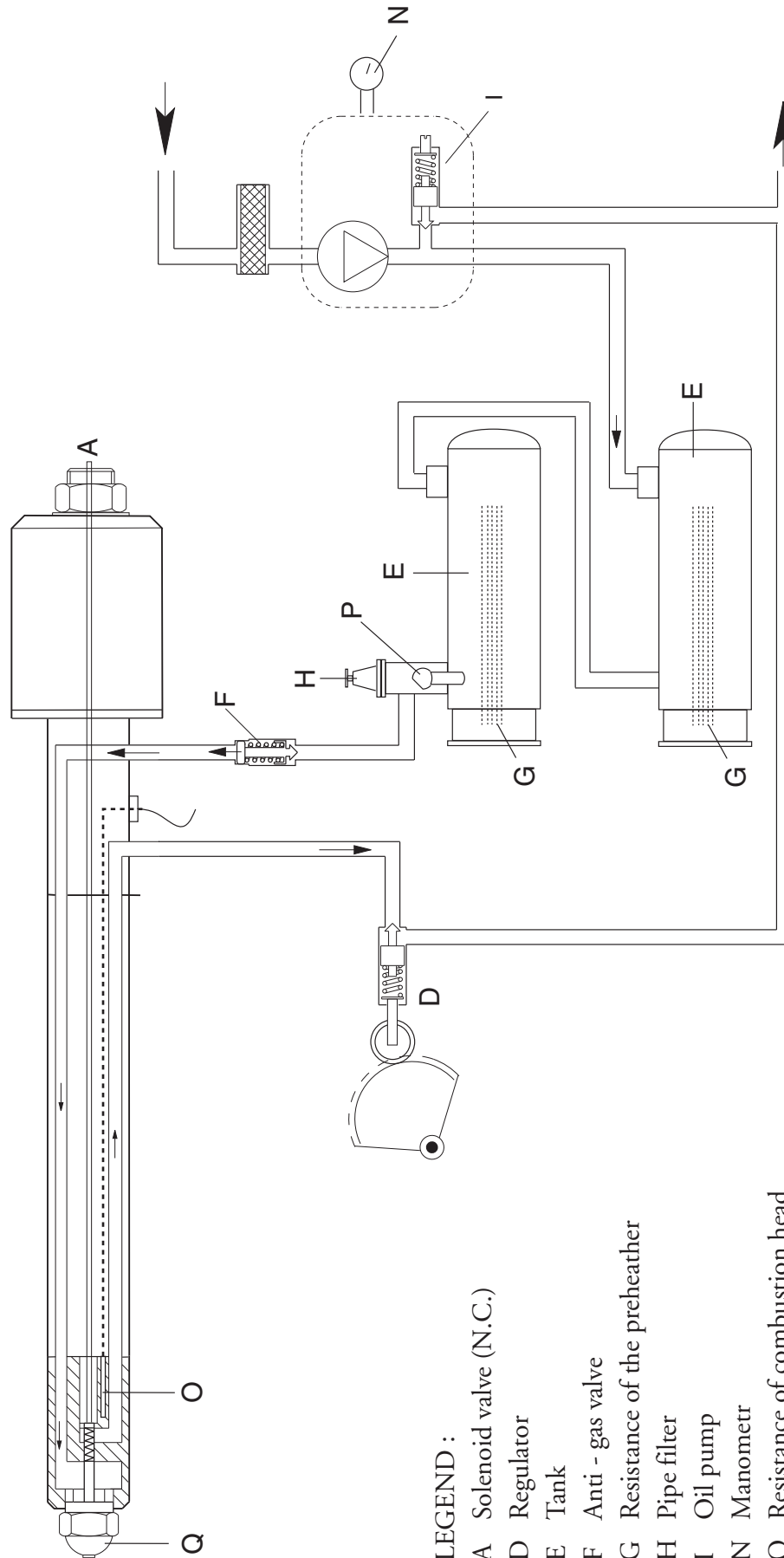

LEGEND :

- A Solenoid valve (N.C.)
- D Regulator
- E Tank
- F Anti - gas valve
- G Resistance of the preheater
- H Pipe filter
- I Oil pump
- N Manometr
- O Resistance of combustion head
- P Oil temperature sensor
- Q Oil nozzle

POSITION OF IGNITION ELECTRODES

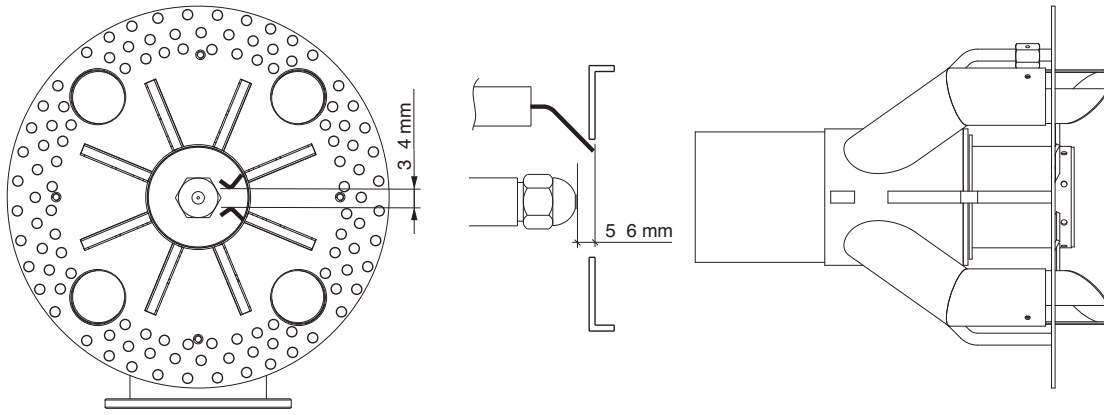

NOZZLE CLEANING AND REPLACEMENT

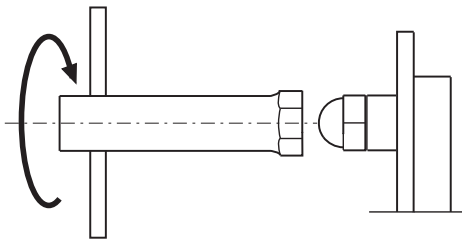

Use only the suitable box wrench provided for this operation to remove the nozzle, taking care to not damage the electrodes. Fit the new nozzle with the same care.

Note: Always check the position of electrodes after having replaced the nozzle (see illustration). A wrong position could cause ignition troubles.

FLUIDICS NOZZLE

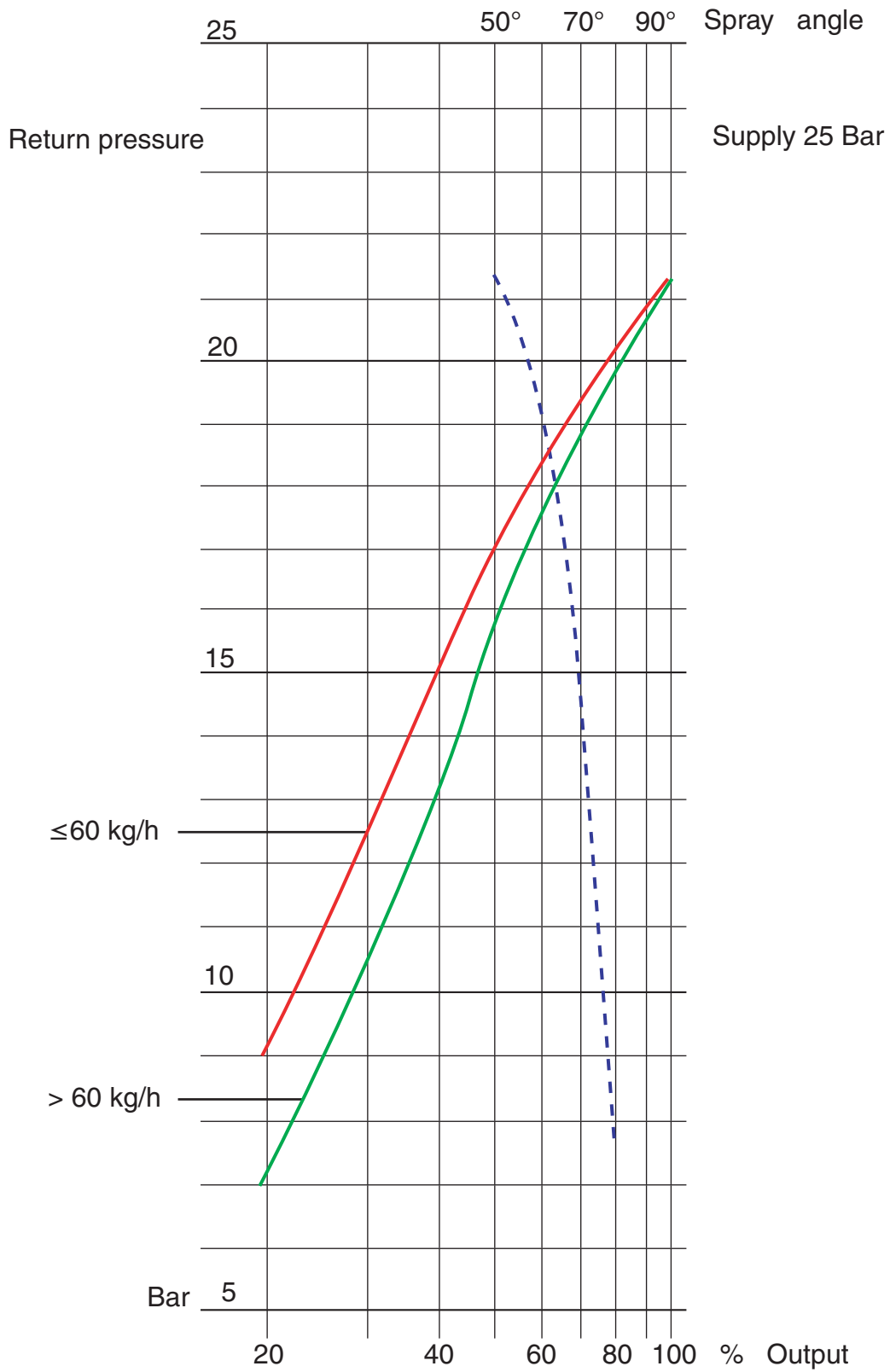

BERGONZO NOZZLE TABLE

Pump pressure (bar)

GPH	Atm	3	4	5	6	7	8	9	10	11	12	13	14	15	16	17	18	19	20	21	22	23	24	25	26	27	28	29	30	
		Pump pressure (bar)																												
125	A	20	22	23	25	26	27	29	32	34	37	40	44	50	57	65	77	95												
125	B	20	285	280	275	274	272	271	245	235	220	205	190	175	160	145	130	115												
125	A	25	24	25	26	27	28	29	30	31	32	34	35	37	40	43	45	52	60	68	80	95	115							
125	B	25	330	328	325	320	315	307	300	285	280	275	260	250	235	220	190	180	170	168	150	135								
125	A	30	25	26	26	27	28	28	29	30	31	32	33	35	37	38	42	43	46	50	54	60	65	72	80	90	108	130		
125	B	30	370	365	360	355	350	348	345	340	335	328	320	305	300	290	280	270	260	245	240	225	210	190	180	165	150	130		
150	A	20	30	33	34	35	37	39	43	46	50	55	60	68	75	85	100	120												
150	B	20	325	320	315	308	300	290	285	275	260	250	240	220	190	180	160	140												
150	A	25	32	33	34	35	37	37	38	42	45	47	50	55	60	65	70	78	83	94	110	120	150							
150	B	25	375	370	365	363	358	355	350	345	330	320	310	300	285	275	260	250	240	220	195	180	150							
150	A	30	35	36	36	37	37	37	39	41	42	45	46	48	50	54	58	62	65	70	75	80	88	95	110	120	140	180		
150	B	30	420	420	415	410	405	400	395	390	380	375	365	350	345	340	320	300	290	280	270	250	240	220	200	180				
175	A	20	35	37	39	42	44	46	48	55	58	62	68	75	84	95	118	155												
175	B	20	350	350	349	348	330	325	315	300	290	280	265	248	225	195	175	155												
175	A	25	35	36	37	41	42	44	45	47	50	52	58	62	65	70	78	88	95	110	120	140	170							
175	B	25	395	390	385	382	380	378	370	360	350	348	330	325	315	300	280	275	260	240	225	200	170							
175	A	30	42	43	44	45	46	47	48	50	52	55	58	60	62	65	70	72	78	85	90	100	110	118	135	158	190			
175	B	30	440	440	435	430	425	420	415	410	408	400	390	380	370	360	350	330	320	300	285	275	260	250	235	220	190			
200	A	20	38	40	42	44	47	50	55	60	65	70	80	90	100	120	140	170												
200	B	20	400	398	388	380	370	360	350	340	330	320	300	280	275	250	230	210												
200	A	25	42	43	43	44	45	47	50	52	55	60	65	70	78	85	95	105	115	130	150	170	220							
200	B	25	450	448	448	445	440	430	425	412	405	400	390	380	375	360	345	325	315	290	280	260	220							
200	A	30	48	49	50	51	52	53	55	56	58	60	62	64	68	70	75	80	85	92	100	110	120	130	150	175	200			
200	B	30	500	500	495	490	485	480	475	470	460	450	440	430	420	410	395	385	375	350	340	325	315	300	290	275	260			
225	A	20	42	43	45	47	48	52	56	60	65	70	80	90	100	115	140	180												
225	B	20	420	410	405	400	395	380	375	365	350	345	335	320	300	280	265	250												
225	A	25	45	46	47	48	50	52	55	58	60	63	68	73	80	90	98	108	120	140	160	180	225							
225	B	25	475	468	460	455	450	445	437	425	410	400	380	375	360	350	340	315	300	280	260	240								
225	A	30	50	50	51	52	52	53	54	55	57	60	62	66	68	75	80	88	94	100	110	120	130	140	155	175	200	240		
225	B	30	510	510	505	503	500	495	490	480	460	460	440	430	420	410	400	390	380	370	360	350	340	325	310	300	285	275		
250	A	20	42	44	46	47	50	55	60	65	70	80	90	100	115	140	160	220												
250	B	20	425	415	408	403	400	380	375	365	350	338	325	300	280	265	250	240												
250	A	25	46	47	49	50	52	55	58	60	63	66	72	78	85	92	100	110	130	140	165	200								
250	B	25	480	475	475	470	465	450	445	440	425	410	400	380	375	355	340	330	310	300	280	275								
250	A	30	52	52	52	53	54	55	58	60	62	65	68	72	78	82	90	95	105	105	125	135	150	165	180	220	260			
250	B	30	520	515	515	510	510	505	500	490	480	475	460	450	440	430	420	400	380	370	360	350	340	325	310	300	285	275		
275	A	20	52	53	55	58	60	63	68	75	80	90	100	115	125	150	170	225												
275	B	20	540	530	520	510	500	490	475	450	440	420	400	375	350	325	300	275												
275	A	25	55	56	57	58	60	64	68	70	75	80	85	95	100	115	125	135	150	170	190	225	265							
275	B	25	600	600	595	590	580	570	560	550	540	525	510	500	480	460	440	425	400	375	350	325	300							
275	A	30	60	61	62	63	64	65	66	67	70	74	78	82	88	95	100	110	118	125	135	150	165	180	200	240	275			
275	B	30	680	675	668	662	658	650	640	630	620	610	600	590	580	565	555	545	525	500	480	460	440	425	400	375	350			

A= nozzle output B= pump output

output (kg/h)

BERGONZO NOZZLE TABLE

Pump pressure (bar)

GPH	Atm	3	4	5	6	7	8	9	10	11	12	13	14	15	16	17	18	19	20	21	22	23	24	25	26	27	28	29	30	
300	A	20	55	58	60	64	65	70	76	85	92	105	118	135	145	175	200	270												
300	B	20	550	535	525	515	500	485	470	450	430	410	380	375	360	330	310	280												
300	A	25	24	25	26	27	28	29	30	31	32	34	35	37	40	43	45	52	60	68	80	95	115							
300	B	25	330	328	325	320	315	307	300	285	280	275	260	250	235	220	190	180	170	168	150	135								
300	A	30	25	26	26	27	28	28	29	30	31	32	33	35	37	38	42	43	46	50	54	60	65	72	80	90	108	130		
300	B	30	370	365	360	355	350	348	345	340	335	328	320	305	300	290	280	270	260	245	240	225	210	190	180	165	150	130		
325	A	20	58	62	65	68	72	78	88	95	110	118	135	150	170	200	240	290												
325	B	20	570	560	550	530	510	500	485	475	450	440	425	400	370	350	330	300												
325	A	25	65	67	69	72	74	75	80	85	90	98	105	115	125	140	160	170	190	225	270	320								
325	B	25	650	643	638	630	628	620	610	600	590	580	565	540	520	500	475	450	425	400	375	350								
325	A	30	68	69	70	71	73	75	78	82	88	92	98	105	110	120	130	140	150	165	180	200	225	250	280	320	360			
325	B	30	720	715	710	705	702	700	690	680	670	655	620	610	600	580	570	550	520	500	500	480	460	440	420	400	380			
350	A	20	64	68	70	75	80	90	98	105	118	130	145	160	180	210	250	310												
350	B	20	620	600	590	580	570	550	530	500	480	460	440	420	400	375	360	340												
350	A	25	68	69	70	75	80	85	90	98	105	112	120	130	145	160	170	190	210	240	270	300	350							
350	B	25	700	700	690	680	670	660	650	630	610	590	580	550	520	500	480	465	450	430	410	380	360							
350	A	30	68	69	70	73	78	82	88	92	98	105	110	120	128	138	145	160	170	190	210	225	250	275	300	350	375			
350	B	30	790	780	770	760	750	740	720	710	700	690	680	665	650	625	610	590	570	550	520	505	490	475	440	425	400			
375	A	20	72	76	82	88	94	105	115	125	140	155	170	195	225	250	300													
375	B	20	630	615	600	590	580	565	550	520	490	475	450	425	400	375	360													
375	A	25	78	80	85	90	95	100	105	110	120	130	140	155	170	190	200	230	250	280	325	375								
375	B	25	700	690	680	670	660	650	640	625	615	600	580	565	550	520	500	480	460	440	420	400								
375	A	30	90	92	93	95	98	100	105	110	115	120	130	140	150	160	170	180	200	220	240	260	280	320	350	400				
375	B	30	800	790	786	778	770	760	750	730	710	700	690	670	650	630	610	600	590	570	550	530	510	490	470	440				
400	A	20	85	90	98	105	115	125	135	150	165	185	210	240	270	320														
400	B	20	610	605	595	585	575	565	550	520	500	480	460	440	420	400														
400	A	25	85	90	98	104	110	118	125	135	145	155	170	190	200	225	250	280	310	360	400									
400	B	25	710	705	700	695	690	680	670	650	630	610	590	580	560	540	520	500	480	450	425									
400	A	30	100	102	106	110	114	117	120	130	138	148	158	170	180	195	210	230	250	275	300	340	360	400	440					
400	B	30	800	790	786	778	770	760	750	730	710	700	690	670	650	630	610	600	590	570	550	530	510	490	470					
425	A	20	78	80	85	90	95	100	110	120	135	150	170	190	220	250	300	350												
425	B	20	700	690	680	670	650	630	615	600	590	570	530	510	490	450	410	380												
425	A	25	85	88	90	93	95	100	105	110	120	130	140	150	165	180	195	225	250	280	325	380								
425	B	25	750	745	740	730	720	710	700	685	675	665	650	630	610	600	580	560	540	515	490	430								
425	A	30	91	92	94	96	98	99	100	104	110	118	128	138	145	158	168	180	195	210	235	260	280	320	350	400	450			
425	B	30	820	816	812	808	804	800	780	770	760	750	740	730	720	710	695	680	650	625	600	590	570	540	515	490				
450	A	20	86	90	94	98	105	115	125	135	150	170	195	225	250	280	340	380												
450	B	20	700	685	660	645	635	620	605	585	570	545	530	515	490	470	440	410												
450	A	25	92	95	100	105	110	115	120	130	140	150	165	175	190	210	230	260	280	325	375	425								
450	B	25	805	800	790	775	760	745	730	715	700	690	670	650	625	605	580	560	540	520	500	480								
450	A	30	100	102	105	108	111	114	117	120	130	140	150	160	170	180	190	220	240	260	280	310	350	380	425	475				
450	B	30	860	856	850	842	834	826	818	810	790	760	750	740	730	720	700	680	660	640	620	600	580	540	520	500				

output (kg/h)

A= nozzle output

B= pump output

BERGONZO NOZZLE TABLE

Pump pressure (bar)

GPH	Atm	3	4	5	6	7	8	9	10	11	12	13	14	15	16	17	18	19	20	21	22	23	24	25	26	27	28	29	30	
475	A	82	88	95	100	110	120	130	145	160	170	195	225	260	300	360														
475	B	800	780	760	740	720	700	680	655	625	600	580	560	520	480	440														
475	A	98	102	108	112	116	120	130	140	150	160	170	180	195	225	250	275	300	350	400	475									
475	B	910	905	900	880	860	840	820	800	780	750	730	710	690	670	650	620	590	560	530	500									
475	A	104	107	110	113	117	120	125	135	145	155	163	170	180	190	200	225	250	275	300	325	360	390	440	480					
475	B	1000	990	975	965	945	930	915	900	890	880	860	840	820	800	780	760	730	700	680	660	640	620	590	460					
500	A	94	102	106	113	120	130	150	170	190	210	230	250	280	325	380														
500	B	800	780	760	740	720	710	680	660	640	610	580	560	520	500	475														
500	A	100	104	108	116	120	130	140	150	160	170	190	210	230	250	270	325	350	400	475										
500	B	900	895	880	865	850	845	830	815	800	780	750	720	700	670	650	620	600	580	550										
500	A	110	113	117	120	125	130	135	140	150	160	170	180	190	220	250	280	250	300	325	350	380	425	480	520					
500	B	1000	990	980	970	960	950	940	925	910	900	880	860	840	820	800	775	750	725	700	775	750	725	600	575					

A= nozzle output B= pump output

output (kg/h)

TROUBLESHOOTING

YEARLY CHECKS

The burner's periodical check (firing head, electrodes etc.) must be carried out by authorised personnel one or two times per year, depending on the utilisation. Before going on with the maintenance controls of the burner, it should be advisable to check its general conditions, according to the following steps:

Unplug the burner; close the fuel cock; shut down the gas supply; remove burner's cover and clean the fan and air intake; clean the firing head and check the electrode's position; reassemble all the parts; check the connection's sealing; check the chimney; start the burner and check the combustion flue ($CO_2 = 9.5 \div 9.8$; $O = \text{lower than } 75 \text{ ppm}$).

BEFORE EVERY INTERVENTION CHECK:

The electric system is duly powered and the burner is plugged in.

The gas pressure must be the suitable one and the gas cock open.

The control devices must be properly connected.

When all the above conditions are met, start the burner by pressing the lockout enable pushbutton.

Check the burner's cycle.

THE BURNER DOES NOT START:

Check the ON/OFF switch, the thermostats, the motor and the gas pressure.

The master switch is in position "0". Fuses are blown out.

The control box is faulty.

THE BURNER RUNS THE PREPURGING AND SWITCHES TO LOCKOUT AT THE END OF CYCLE:

Check the fan and the air pressure.

Check the air pressure switch.

Control box faulty. Ignition transformer faulty.

Check the ignition cable. Electrodes are dirty or in wrong position.

Nozzles are clogged or worn. Filters are clogged. Heavy-oil pressure is too low.

Combustion air's flow rate too high related to nozzle output.

THE BURNER RUNS THE PREPURGING BUT DOES NOT IGNITE:

Check the position of the electrodes; check the ignition cable;

Check the ignition transformer;

Check the control box.

THE BURNERS IGNITES BUT SWITCHES TO LOCKOUT AFTER THE SAFETY TIME:

Check phase and neutral for a correct connection.

Check gas solenoid valve.

Check the position of UV-cell and its connection.

Check the control box.

Check nozzles (clogged or worn).

The UV-cell does not detect the flame.

The filters are clogged. Heavy-oil pressure too low.

Combustion air's flow rate too high related to nozzle output.

THE BURNERS IGNITES BUT SWITCHES TO LOCKOUT AFTER FEW MOMENTS:

Check gas governor and gas filter.

Check gas pressure through a manometer.

Check ionization value (min. $70 \mu A$).

THE BURNER DOES NOT SWITCHES TO HIGH FLAME:

Manual selector switch in wrong position.

Faulty control box. High flame solenoid valve's coils faulty.

Air damper's jacket faulty or wrongly adjusted.

Index

1 - Caracteristiques techniques

- Caracteristiques techniquesp.37
- Dimensions d'encombrementp.37

2 - Installation

- Connexion électriquep.38
- Connexion au reseau gazp.38

3 - Démarreur et régléments du gaz

- Demarrage du brûleurp.38
- Reglage de la combustionp.38
- Cycle de fonctionnement de coffret de securitep.39
- Reglage air / gazp.39,40
- Reglage tete de combustion / pressostatp.41
- Controle systeme detection de flammep.41
- Removing firing headp.42

4 - Démarreur et régléments du fuel lourd

- Liaison fuel lourd au brûleurp.42
- Vérificationsp.42
- Fonctionnement du brûleurp.43
- Regulationp.43
- Circuit hydrauliquep.44,45
- Position des electrodes et nettoyagep.46
- Tabelau gicleursp.47,48,49,50,51

5 - Entretien d'utiliser-et

- Anomalies de fonctionnementp.52

CARACTERISTIQUES DU BRULEUR

MODELE		Multiflam 700.1	Multiflam 800.1	Multiflam 1000.1	Multiflam 1200.1
Puissance thermique max.	kW	7.500	8.500	10.500	13.000
	kcal/h	6.465.000	7.327.500	9.052.000	11.207.000
Puissance thermique min.	kW	1.500	2.000	2.500	2.700
	kcal/h	1.290.000	1.724.000	2.155.000	2.327.600
Pression Gaz Naturel	mbar	60÷700	85÷700	115÷700	160÷700
Pression LPG	mbar	125÷700	185÷700	110÷700	160÷700
Tension d'alimentation 50 Hz	V	230/400	230/400	230/400	230/400
Combustible :		Gaz Naturel (L.C.V. 8.570 kcal/Nm ³), GPL (L.C.V. 22.260 kcal/Nm ³) Fuel Lourd (L.C.V. 9.800 kcal/kg max. visc 50°E at 50°C)			

DIMENSIONS D'ENCOMBREMENT

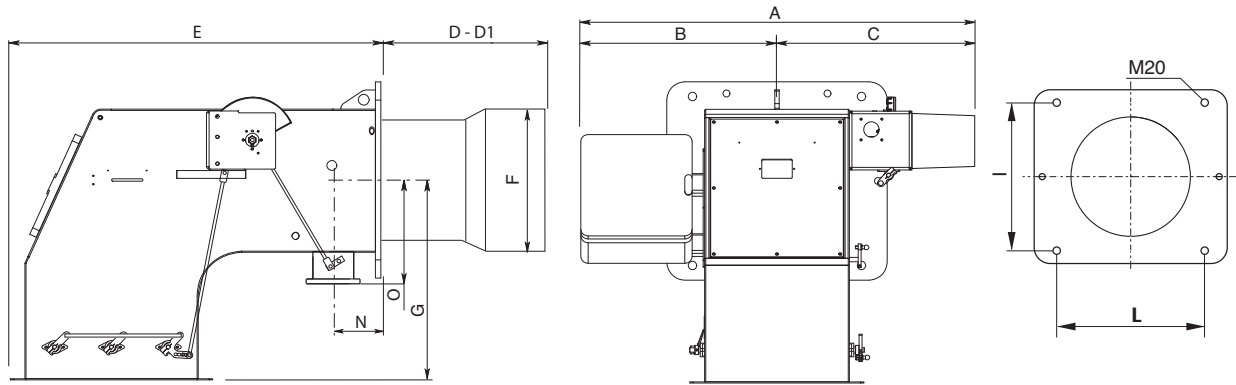

D = tête courte D1 = tête longue Dimensions (mm)

MODELE	A	B	C	D	D1	E	F	G	I	L	M	N	O
Multiflam 700.1 TS	1170	540	630	470	-	1030	420	550	460	460	M20	195	232
Multiflam 800.1 TS	1170	540	630	470	-	1030	420	550	460	460	M20	195	232
Multiflam 1000.1 TS	1170	540	630	470	-	1030	420	550	460	460	M20	195	232
Multiflam 1200.1 TS	1170	540	630	470	-	1030	450	550	460	460	M20	195	232

BRIDE AIR

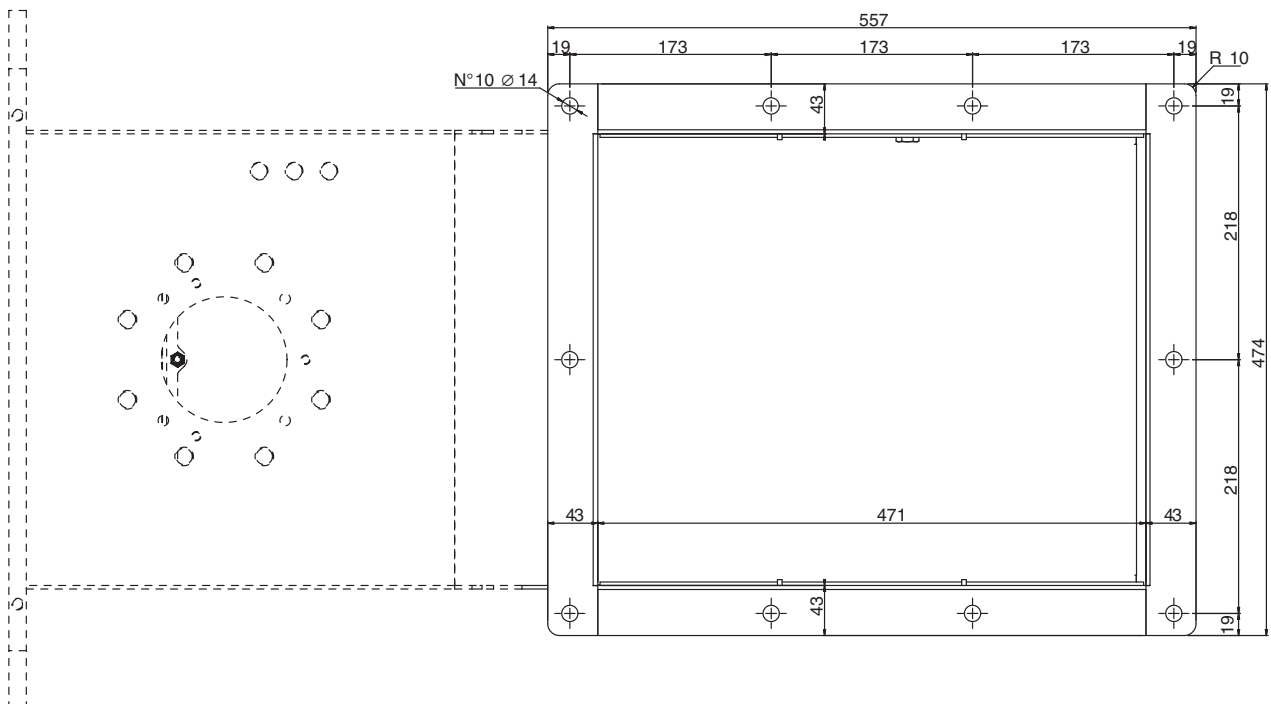

CONNEXION ELECTRIQUE

Tous les brûleurs sont essayés à 400 V, 50 Hz triphasé, avec neutre pour les auxiliaires. Dans le cas où il fût nécessaire alimenter les brûleurs à 230 V, 50 Hz triphasé sans neutre, effectuer les modifications nécessaires suivant le schéma électrique du brûleur et contrôler que le relais thermique soit dans la plage d'absorption du moteur. Vérifier, en outre, le sens de rotation du ventilateur.

CONNEXION AU RESEAU GAZ

Une fois que le brûleur est connecté à la tuyauterie gaz, il faudra s'assurer que cette dernière soit parfaitement étanche, et que la cheminée ne soit pas obstruée. Une fois ouvert le robinet du gaz, purger très soigneusement la tuyauterie par la prise de pression, et contrôler, ensuite, la valeur de la pression à l'aide d'un manomètre. Brancher le système et régler les thermostats à la température désirée. A la fermeture des thermostats, le dispositif de contrôle d'étanchéité, effectuera un essais des vannes. Au bout de l'essai, le brûleur obtiendra le consensus pour le démarrage.

DEMARRAGE DU BRULEUR

Avant de démarrer le brûleur, s'assurer qu'il soit installé correctement. Vérifier les connexions électriques suivant les plans ainsi que la tuyauterie du système. Avant d'effectuer les connexions électriques- veiller à ce que le voltage corresponde aux données indiquées sur la plaquette des caractéristiques techniques. Le schéma de la connexion électrique, ainsi que le cycle de démarrage- sont illustrés séparément. Pour connecter l'appareillage au brûleur, suivre le schéma. Veiller soigneusement à la connexion du neutre et la phase: jamais les inverser. Contrôler la connexion à terre du système. Avec les moteurs triphasés, vérifier le sense giratoire (voir la flèche). Purger l'air et les impuretés de la tuyauterie du gaz, et vérifier que la pression du gaz soit dans les limites indiquées sur la plaquette. Ce contrôle doit être effectué à l'aide d'un manomètre à gaz connecté à la prise de pression correspondante du brûleur. On démarre le moteur et il commence la preventionilation. Le motoréducteur porte le volet de l'air à l'ouverture maximale dans 30 secondes. Lors que le motoréducteur est complètement ouvert, un signal transmis au dispositif de contrôle démarre un cycle de pre-ventilation de 66 secondes (36 sec. LFL 1.333) env. A la fin de cette dernière, le motoréducteur portera le volet en petite allure, ainsi permettant l'allumage du brûleur à la portée minimale. En même tempst on a l'alimentation du transformateur d'allumage et, après 3 secondes (pre-allumage) on aura l'alimentation des vannes du gaz. A ce point, la vanne à papillon règle la portée du gaz dans la tête de combustion. Deux secondes après l'ouverture des vannes, le transformateur est exclus du circuit. En cas de faute d'allumage, le brûleur va en blocage dans deux secondes. Le brûleur est allumé à la puissance minimale (env. 30% de la puissance maximale). Le dispositif modulateur (si prévu) fera ouvrir le servomoteur à la puissance maximale, ou bien il l'arrêtera à la puissance intermédiaire requise par le système. L'ouverture du servomoteur fera ouvrir gaz et air en manière proportionnelle, de façon à avoir une combustion optimale à toutes les portées (30% - 100%). A la fin du fonctionnement le servomoteur se porte en position de fermeture.

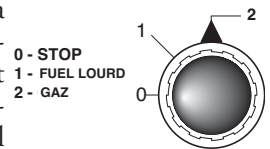

REGLAGE DE LA COMBUSTION

ATTENTION : *por obtenir un réglage correct de la combustion et du débit thermique, il faut effectuer l'analyse des fumées en utilisant les instruments appropriés. Le réglage de la combustion et du débit thermique doit être fait en même temps qu'une analyse des produits de combustion, en veillant à ce que les valeurs relevées soient correctes, et qu'elles répondent toujours aux normes de sécurité en vigueur.*

CETTE OPERATION DOIT ETRE FAITE PAR DU LA PERSONNEL QUALIFIE ET AUTORISE PAR LA SOCIETE ECOFLAM BRUCIATORI SPA .

COFFRETS DE SECURITE LANDIS & STAEFA MOD. LFL1.622-1.333

FR

Ref.	Description	Temps
t1	Temps de contrôle du pressostat air	8"
t2	Temps de pre-ventilation	66"(36")
t3	Temps de sécurité	2"
t4	Temps de pre-allumage	4"
t5	tempo per il consenso di funzionam. alla minima potenza della valvola di lavoro del combustibile.	10"
t6	tempo per il consenso di funzionam. alla massima potenza della valvola di lavoro del combustibile.	10"

Le coffret de sécurité démarre la turbine et commence le pre-balayage de la chambre de combustion. Le pressostat air contrôle la pression de l'air de ventilation afin que le fonctionnement soit correct. A la fin du pre-balayage le transformateur d'allumage s'enclenche, par une étincelle entre les électrodes, suivi par les les vannes gaz (soupape de sécurité VS et soupape de travail VL). En cas de faute d'allumage ou coupure accidentelle du brûleur la sonde à ionisation met le brûleur en sécurité dans le temps de sécurité. En cas de coupure du gaz ou de baisses de pression, le pressostat du gaz de pression minimum coupe le fonctionnement du brûleur.

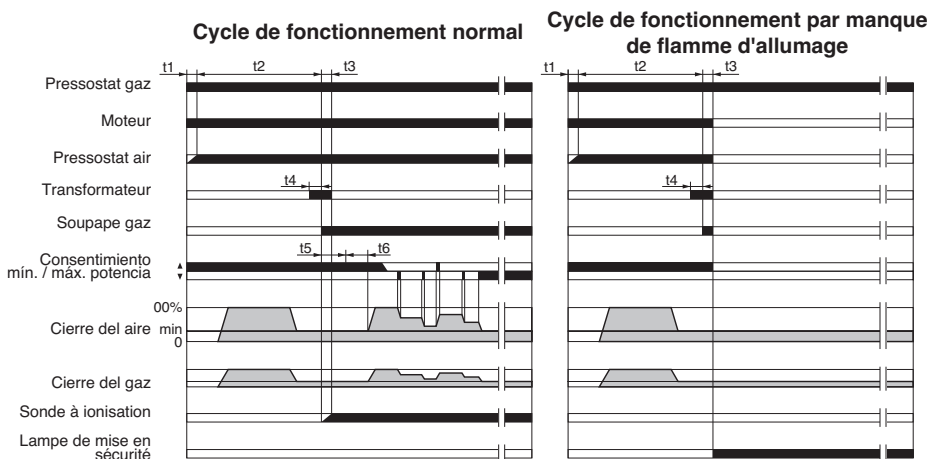

SERVOMOTEUR LANDIS & STAEFA SQM 50.481A2

Enlever le couvercle pour avoir accès aux cames de régulation. La régulation des cames doit être faite à l'aide de la clé en dotation. Description:



- I - Came de régulation de la position d'ouverture en grande Allure(GAZ-FUEL LOURD).
- II - Came de régulation de la position du clapet de l'air à la coupure.
- III - Came de régulation de la position d'ouverture en min. Allure (GAZ).
- IV - Came de régulation de la position d'ouverture en min. Allure (FUEL LOURD).
- V - Came de régulation de la position d'ouverture en petite Allure GAZ.
- VI - Came de régulation de la position d'ouverture en petite Allure FUEL LOURD.
- VII - Came de régulation de la position d'ouverture en grande Allure GAZ.
- VIII - Came de régulation libre (non utilisé).

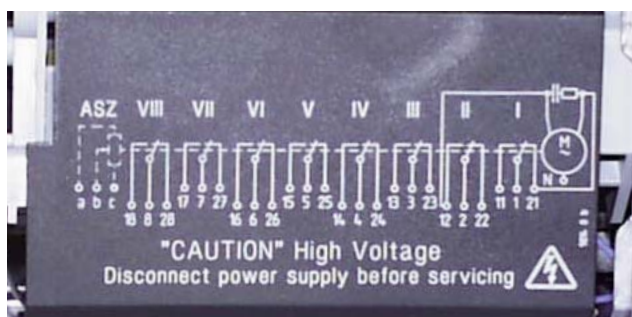

CALCUL DU DEBIT DE FONCTIONNEMENT DU BRULEUR

Pour calculer le débit de fonctionnement, en kW, du brûleur, procéder de la manière suivante:

- Vérifier au compteur la quantité de litres débités, ainsi que la durée de la lecture, ensuite procéder au calcul du débit par la formule suivante:

$$\frac{e}{s} \times f = \text{kW}$$

- e = Litres de gaz
 - s = Temps en secondes
- | | |
|---|-------------|
| f | G20 = 34,02 |
| | G25 = 29,25 |
| | G30 = 116 |
| | G31 = 88 |

REGLAGES DES DEBITS AIR ET GAZ

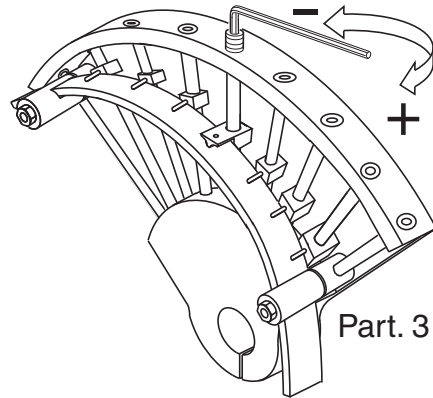
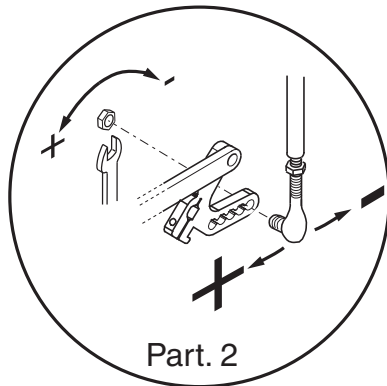

COMMUTATEUR

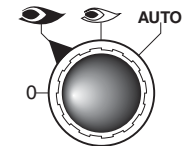

0 = blocage du servomoteur dans une position intermédiaire

1 = fonctionnement à la puissance maximale

AUTO = fonctionnement à la puissance minimale

AUTO = fonctionnement automatique

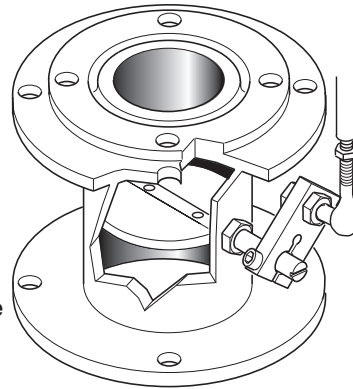

REGLAGE DE LA PUISSANCE MINIMALE DU GAZ

Positionner le commutateur qui se trouve dans le tableau de bord, dans la position 2 et agir comme il suit: Pour régler le débit minimale du gaz agir avec la clé à six pans sur la vis de la came et modifier l'angle du clapet gaz de la vanne à papillon.

REGLAGE DE LA PUISSANCE MAXIMALE DU GAZ

Positionner le commutateur qui se trouve dans le tableau de bord, dans la position 1 et agir comme il suit: Pour régler le débit maximale du gaz agir sur l'électrovanne de réglage jusqu'à obtenir le débit correct pour la chaudière.

REGLAGE DU DÉBIT MAXIMALE DE L'AIR

- Desserrer la vis de fixation de la tige et placer la même dans la position correcte.
A la fin du réglage resserrer la vis de la tige.

REGLAGE DES PUISSANCES INTERMEDIARES DU GAZ

Actionner le servomoteur avec le commutateur (ouvert / fermé) e placer sur la position 0 pour l'arreter. Pour le réglage, agir comme il suit. Repeter les passages pour les autres points des cammes.

Reglage des débits intermédiaires du gaz (voir image, partie 3):

- Avec une clé à six pans, modifier la position de la lame guide de la came; serrant le débit augmente, desserrant le débit diminue.

REGULATION DE LA COMBUSTION

ATTENTION: Afin d'obtenir une correcte régulation de la combustion et de la portée thermique, celles-ci doivent être effectuées en même temps à une analyse de la combustion, à se faire par des instruments opportuns, en vérifiant que les données sont correctes et correspondantes aux normes de sécurité locales. Les opérations de régulations doivent être effectuées par des techniciens experts et qualifiés, autorisés par Ecoflam Bruciatori S.p.A.

REGULATION DE LA TETE DE COMBUSTION

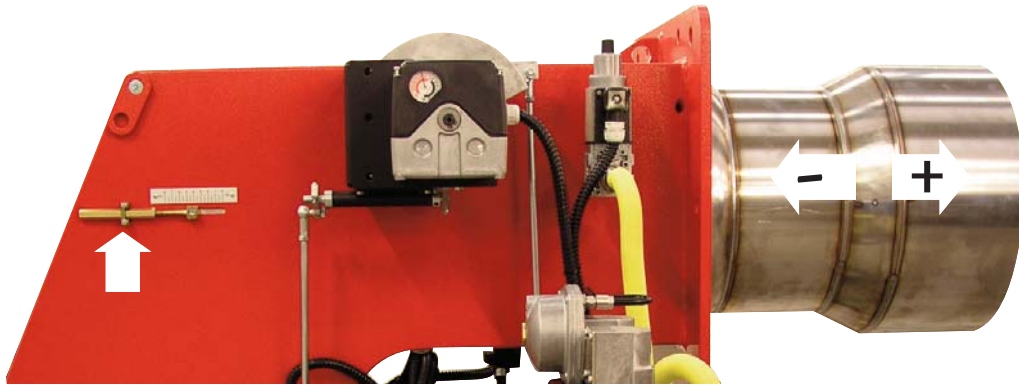

REGLAGE DU PRESSOSTAT GAZ DE MINIMUM

Dévisser les vis I et L et enlever le couvercle M. - Positionner le régulateur N à une valeur équivalente au 60% de la pression nominale d'alimentation du gaz (par ex.: pour gaz nat. avec pression nom. de 20 mbar, positionner le régulateur à une valeur de 12 mbar; pour G.L.P. avec pression nom. G30/G31 30/37 mbar, positionner le régulateur à 18 mbar). - Remonter le couvercle M et visser les vis I et L.

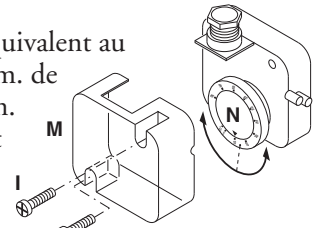

REGULATION DU PRESSOSTAT AIR

Dévisser les vis A et B et enlever le couvercle. Réguler le pressostat air au minimum en tournant le régulateur D en position 1. Démarrer le brûleur en 1e allure et effectuer une analyse de la combustion. A l'aide d'un petit carton obstruer progressivement le conduit d'aspiration de l'air jusqu'à obtenir une augmentation de CO₂ de 0,5±0,8% ou bien, si l'on dispose d'un manomètre connecté à la prise de pression E, jusqu'à obtenir une chute de pression de 1 mbar (10 mm C.E.). Augmenter progressivement la valeur de la régulation du pressostat jusqu'à obtenir l'arrêt en sécurité du brûleur. Enlever l'obstruction du conduit, visser le couvercle C et démarrer le brûleur en appuyant sur la touche de réarmement du coffret de sécurité.

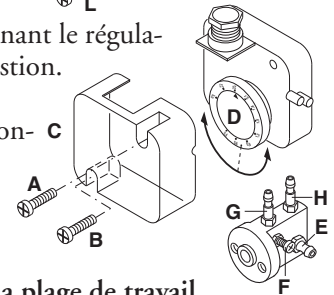

Note: La pression mesurée à la prise de pression E doit être comprise dans les limites de la plage de travail du pressostat. Sinon, dévisser l'écrou de blocage de la vis F et la tourner graduellement: à droite pour réduire la pression; à gauche pour l'augmenter. Enfin serrer l'écrou de blocage.

CONTROLE SYSTEME DETECTION DE FLAMME

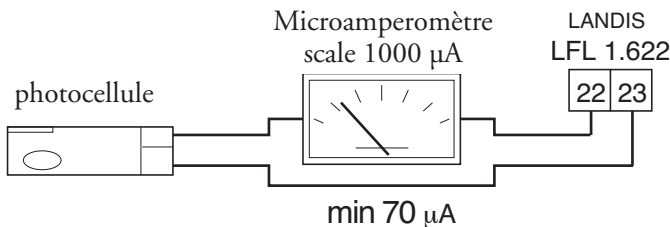

Avec le brûleur éteint, brancher un microamperomètre à courante continue scale 1000 µA. en série à la photocellule. Normalement la valeur minimum du courante de detection de flamme est >70 µA.

FR

COMMENT ENLEVER LE GUEULARD

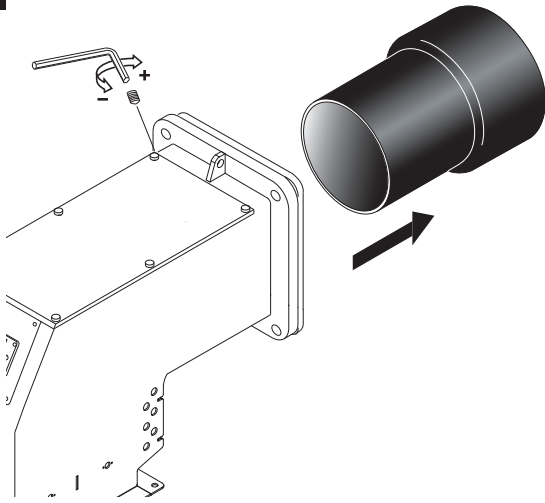

ENLEVEMENT DE LA TETE DE COMBUSTION

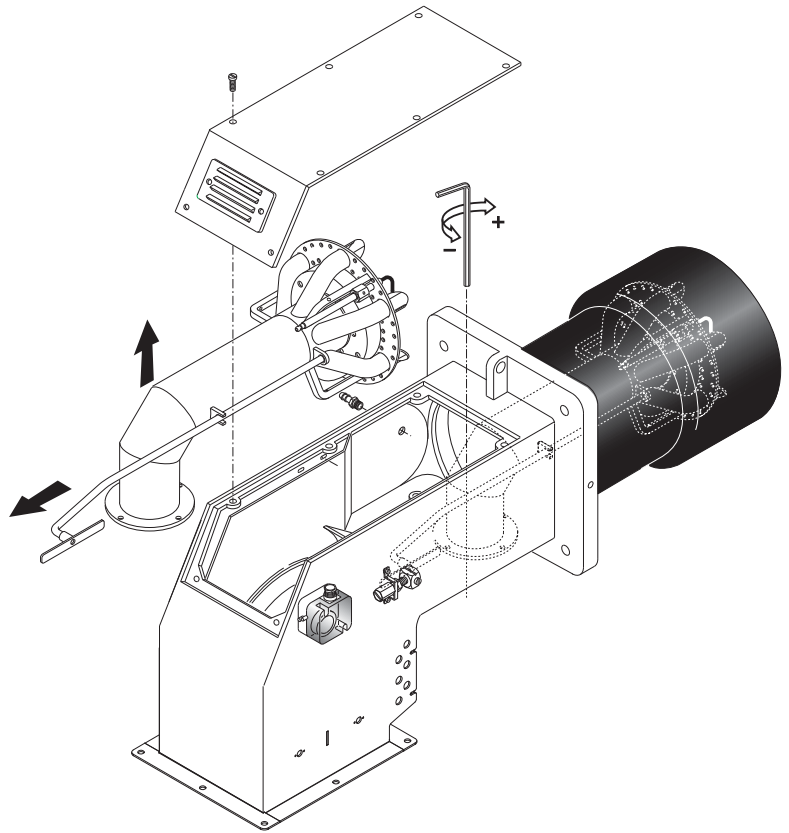

LIAISON FUEL LOURD AU BRÛLEUR

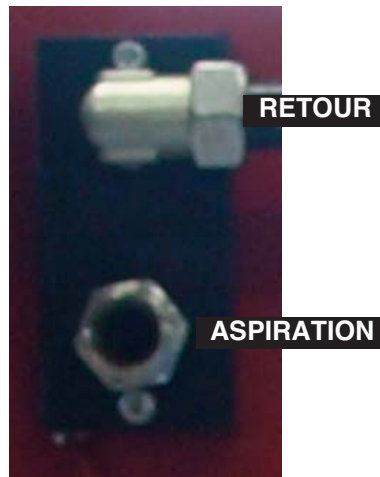

VERIFICATIONS A EFFECTUER POUR UNE INSTALLATION CORRECTE:

Avant de procéder au remplissage du circuit d'alimentation et relative mise en service du brûleur, il serait souhaitable d'effectuer les contrôles suivants:

- La ligne d'alimentation doit être adéquate à la charge absorbée par l'installation
- Les fusibles doivent être à la charge absorbée par l'installation
- Les thermostats de la chaudière doivent avoir été connectés correctement
- Voltage et fréquence doivent être compris dans les limites spécifiés
- Le type de fuel doit être celui spécifié par le constructeur du brûleur
- La section de la tuyauterie d'alimentation doit être adéquate à la portée de fuel requise
- Les filtres, robinets et raccords doivent avoir été dûment installés
- La longueur du gueulard doit être celle spécifiée par le constructeur de la chaudière
- La portée des gicleurs du brûleur doit être adéquate à la puissance de la chaudière

FONCTIONNEMENT DU BRÛLEUR

Quand le brûleur est en position démarrage et que les thermostats chaudière sont enclenchés, les résistances (G) du réchauffeur, les résistances auxiliaires sur pompe et le groupe tête sont sous tension. Quand le thermostat du réchauffeur atteint la valeur fixée (normalement, il faut au minimum 90°C pour garantir un niveau de circulation adéquat), la pompe de démarrage est autorisée (si l'on utilise le thermorégulateur GEFRAN 200, régler le point de consigne de la sortie 1).

Si le système de préchauffage du réservoir est également prévu pour l'emploi d'un échangeur de liquides (eau chaude, vapeur, huile diathermique), le thermostat peut activer un contact du bornier pour donner l'autorisation électrique à l'électrovanne liquides. Ceci n'est pas une solution standard car, normalement, le fluide chauffé est toujours en circulation.

La pompe commence à envoyer le fuel lourd (la tête a déjà été chauffée par sa résistance (O), c'est pourquoi il n'y a pas de résidus de fuel lourd dense froid) qui circule du réservoir à la tête, puis à la ligne de retour de la boucle d'alimentation du fuel lourd. Quand le thermostat de la tête atteint la valeur fixée (normalement, le cycle débute de manière appropriée autour de 70-30°C), l'appareil donne l'autorisation à l'allumage du brûleur. Le servomoteur se positionne automatiquement sur le minimum (voir le chapitre de la régulation) en agissant sur la vanne de l'air et en agissant sur le retour du régulateur de pression du fuel lourd.

L'électroaimant (A) ouvre le gicleur (Q) dans la condition suivante :

- les étincelles des électrodes d'allumage sont générées par le transformateur, qui est également réglé automatiquement par le dispositif de contrôle du brûleur.

Si la cellule de détection ne détecte pas la flamme, cela provoque le blocage du brûleur.

Une fois l'allumage effectué et la période de stabilisation de la flamme écoulée, le système commence à fonctionner en modulation.

- Avant l'allumage, s'assurer que la pompe et les tubes de refoulement sont complètement remplis avec le fuel lourd chaud ; l'absence de fuel lourd peut provoquer le grippage de la pompe.

- En cas de blocage, un voyant s'allume sur le panneau de commande du brûleur ; de plus, un signal de tension est disponible pour la transmission de l'alarme à distance.

- Lors du premier allumage, il est normal que des blocages surviennent (jusqu'à 4 environ) ; pour réarmer, appuyer sur le bouton de l'appareil (qui se trouve dans la partie antérieure du panneau de contrôle du brûleur) afin de répéter le cycle de démarrage. Si les blocages persistent, s'adresser à un technicien qualifié.

N.B. : La condition de l'appareil au moment du blocage peut fournir des indications sur la cause du blocage.

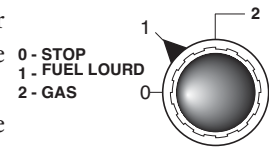

RÉGLAGE DE LA PRESSION DE RETOUR FUEL

Le diagramme représente le système de réglage du retour de fuel pour ces types de brûleurs, qui incorporent un gicleur avec retour variable progressif. Le débit du fuel peut être modifié au moyen du gicleur de retour en modifiant la pression dans le retour. On obtient le débit maximum de fuel quand la pression de la pompe est d'environ 30 bars et que le retour est complètement fermé. On obtient le débit minimum du fioul quand la ligne de retour est complètement ouverte. Pour mesurer la pression en refoulement, monter un manomètre sur la pompe. La pression du retour peut être lue sur le manomètre, monté sur le régulateur de pression, qui équipe le brûleur.

Pression pompe 22-30 bar.

Débit max. brûleur, pression de retour:

FLUIDICS gicleur : 16 ± 19 bar.

BERGONZO gicleur : 20 ± 24 bar.

Débit min. brûleur, pression de retour:

FLUIDICS gicleur : 6 ± 9 bar

BERGONZO gicleur : 4 ± 8 bar

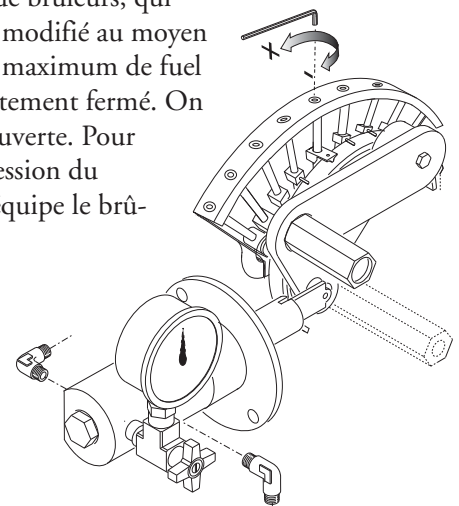

FASE DE PREBARRIDO

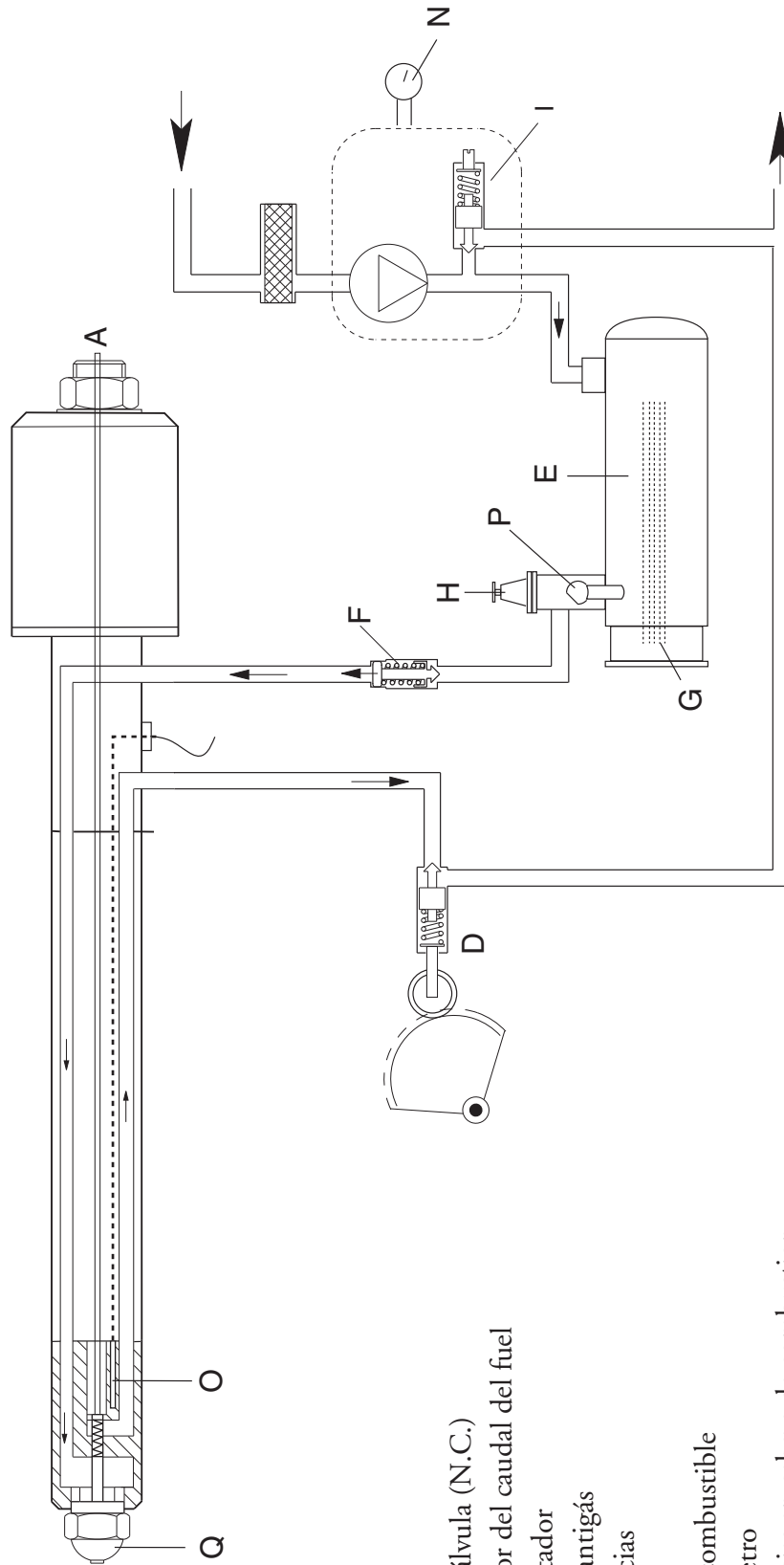

LEYENDA :

- A Electroválvula (N.C.)
- D Regulador del caudal del fuel
- E Precalentador
- F Válvula antigás
- G Resistencias
- H Filtro
- I Bomba combustible
- N Manometro
- O Resistencias en cabeza de combustion
- P Oil temperature sensor
- Q Inyector

FASE DE PREBARRIDO

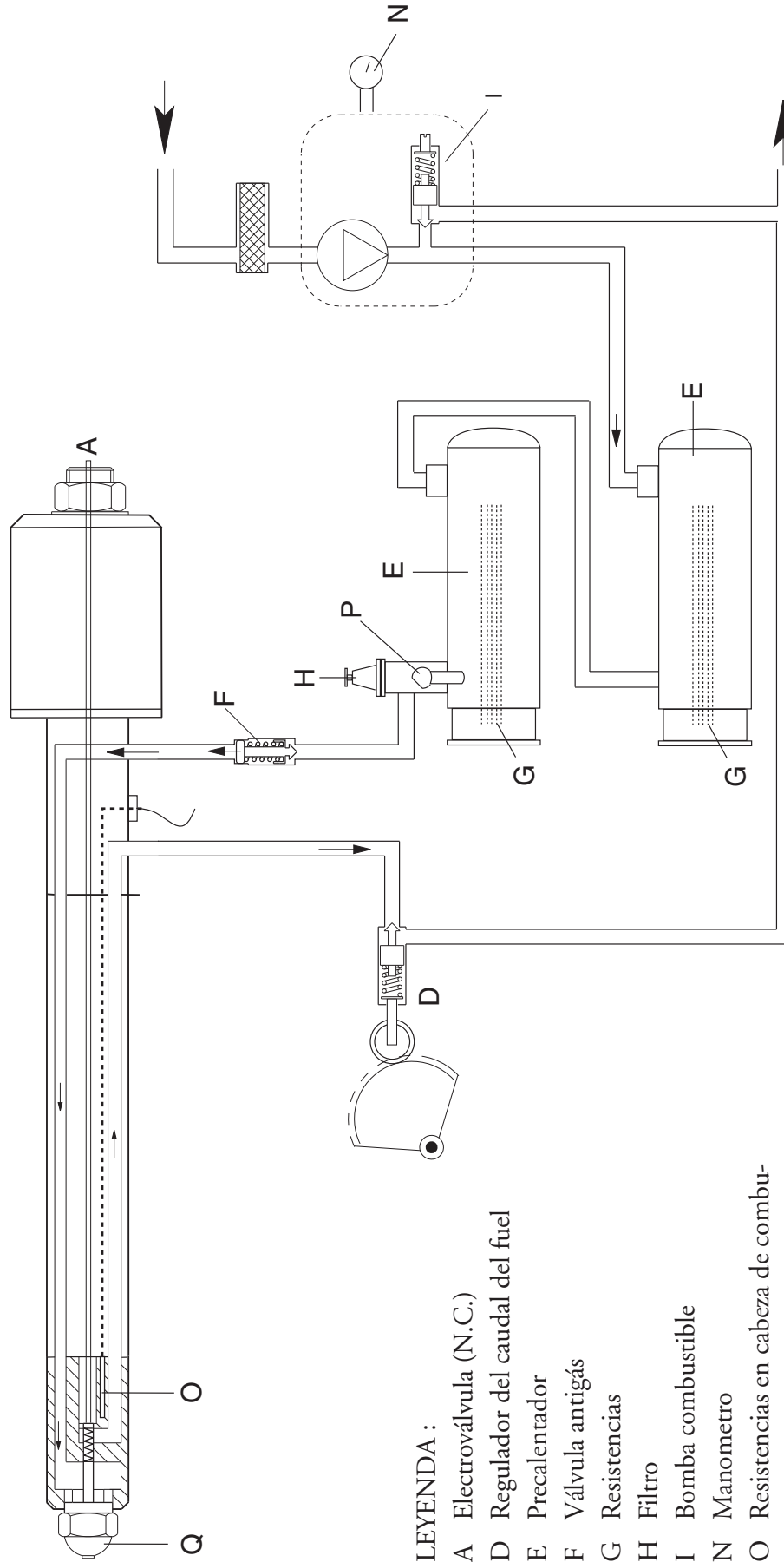

LEYENDA :

- A Electroválvula (N.C.)
- D Regulador del caudal del fuel
- E Precalentador
- F Válvula antigás
- G Resistencias
- H Filtro
- I Bomba combustible
- N Manometro
- O Resistencias en cabeza de combustion
- P Oil temperature sensor
- Q Inyector

POSITION DES ELECTRODES

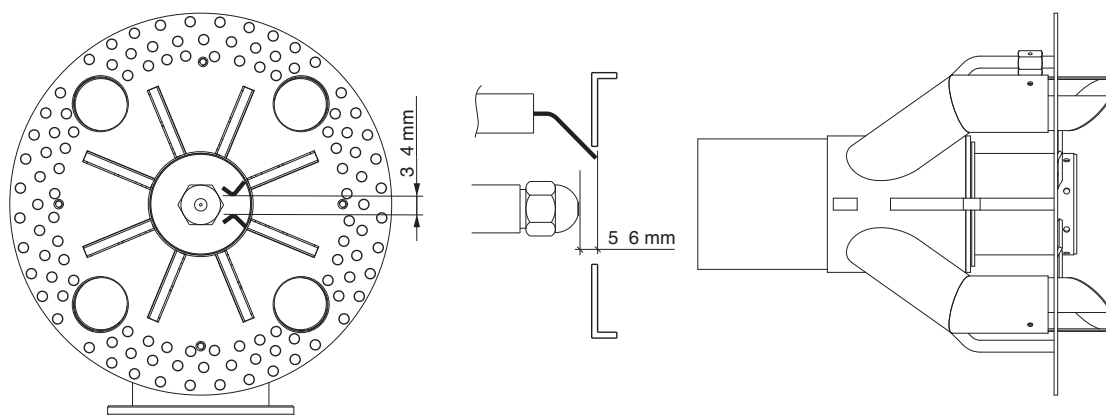

NETTOYAGE ET REMPLACEMENT DU GICLEUR

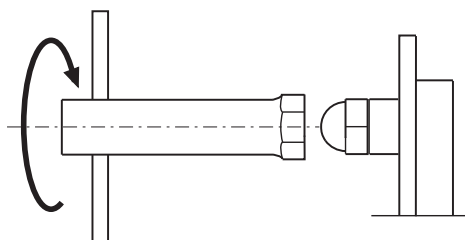

Utiliser seulement la clé en dotation, prévue pour cette opération, pour dévisser le gicleur, en veillant à ne pas endommager les électrodes. Monter le nouveau gicleur par le même soin.

Note: Après le remplacement du gicleur, vérifier toujours la position des électrodes (voir à l'illustration). Une position erronée des électrodes pourrait donner des problèmes d'allumage.

FLUIDICS GICLEUR



TABLEAU GICLEUR BERGONZO
Pression pompe (bar)

GPH	Atm	3	4	5	6	7	8	9	10	11	12	13	14	15	16	17	18	19	20	21	22	23	24	25	26	27	28	29	30
125	A	20	22	23	25	26	27	29	32	34	37	40	44	50	57	65	77	95											
125	B	20	285	280	275	274	272	271	245	235	220	205	190	175	160	145	130	115											
125	A	25	24	25	26	27	28	29	30	31	32	34	35	37	40	43	45	52	60	68	80	95	115						
125	B	25	330	328	325	320	315	307	300	285	280	275	260	250	235	220	190	180	170	168	150	135							
125	A	30	25	26	26	27	28	28	29	30	31	32	33	35	37	38	42	43	46	50	54	60	65	72	80	90	108	130	
125	B	30	370	365	360	355	350	348	345	340	335	328	320	305	300	290	280	270	260	245	240	225	210	190	180	165	150	130	
150	A	20	30	33	34	35	37	39	43	46	50	55	60	68	75	85	100	120											
150	B	20	325	320	315	308	300	290	285	275	260	250	240	220	190	180	160	140											
150	A	25	32	33	34	35	37	37	38	42	45	47	50	55	60	65	70	78	83	94	110	120	150						
150	B	25	375	370	365	363	358	355	350	345	330	320	310	300	285	275	260	250	240	220	195	180	150						
150	A	30	35	36	36	37	37	37	39	41	42	45	46	48	50	54	58	62	65	70	75	80	88	95	110	120	140	180	
150	B	30	420	420	415	410	405	400	395	390	380	375	365	350	345	340	320	300	290	280	270	250	240	220	200	180			
175	A	20	35	37	39	42	44	46	48	55	58	62	68	75	84	95	118	155											
175	B	20	350	350	349	348	330	325	315	300	290	280	265	248	225	195	175	155											
175	A	25	35	36	37	41	42	44	45	47	50	52	58	62	65	70	78	88	95	110	120	140	170						
175	B	25	395	390	385	382	380	378	370	360	350	348	330	325	315	300	280	275	260	240	225	200	170						
175	A	30	42	43	44	45	46	47	48	50	52	55	58	60	62	65	70	72	78	85	90	100	110	118	135	158	190		
175	B	30	440	440	435	430	425	420	415	410	408	400	390	380	370	360	350	330	320	300	285	275	260	250	235	220	190		
200	A	20	38	40	42	44	47	50	55	60	65	70	80	90	100	120	140	170											
200	B	20	400	398	388	380	370	360	350	340	330	320	300	280	275	250	230	210											
200	A	25	42	43	43	44	45	47	50	52	55	60	65	70	78	85	95	105	115	130	150	170	220						
200	B	25	450	448	448	445	440	430	425	412	405	400	390	380	375	360	345	315	290	280	260	220							
200	A	30	48	49	50	51	52	53	55	56	58	60	62	64	68	70	75	80	85	92	100	110	120	130	150	175	200		
200	B	30	500	500	495	490	485	480	475	470	460	450	440	430	420	410	395	385	375	350	340	325	315	300	290	275	260		
225	A	20	42	43	45	47	48	52	56	60	65	70	80	90	100	115	140	180											
225	B	20	420	410	405	400	395	380	375	365	350	345	335	320	300	280	265	250											
225	A	25	45	46	47	48	50	52	55	58	60	63	68	73	80	90	98	108	120	140	160	180	225						
225	B	25	475	468	460	455	450	445	437	425	410	400	380	375	360	350	340	315	300	280	260	240							
225	A	30	50	50	51	52	52	53	54	55	57	60	62	66	68	75	80	88	94	100	110	120	130	140	155	175	200	240	
225	B	30	510	510	505	503	500	495	490	480	460	460	440	430	420	410	400	390	380	370	360	350	340	325	310	300	285	275	
250	A	20	42	44	46	47	50	55	60	65	70	80	90	100	115	140	160	220											
250	B	20	425	415	408	403	400	380	375	365	350	338	325	300	280	265	250	240											
250	A	25	46	47	49	50	52	55	58	60	63	66	72	78	85	92	100	110	130	140	165	200							
250	B	25	480	475	475	470	465	450	445	440	425	410	400	380	375	355	340	310	300	280	275								
250	A	30	52	52	52	53	54	55	58	60	62	65	68	72	78	82	90	95	105	105	125	135	150	165	180	220	260		
250	B	30	520	515	515	510	510	505	500	490	480	475	460	450	440	430	420	400	380	370	360	350	340	325	310	300	285	275	
275	A	20	52	53	55	58	60	63	68	75	80	90	100	115	125	150	170	225											
275	B	20	540	530	520	510	500	490	475	450	440	420	400	375	350	325	300	275											
275	A	25	55	56	57	58	60	64	68	70	75	80	85	95	100	115	125	135	150	170	190	225	265						
275	B	25	600	600	595	590	580	570	560	550	540	525	510	500	480	460	440	425	400	375	350	325	300						
275	A	30	60	61	62	63	64	65	66	67	70	74	78	82	88	95	100	110	118	125	135	150	165	180	200	240	275		
275	B	30	680	675	668	662	658	650	640	630	620	610	600	590	580	565	555	545	525	500	480	460	440	425	400	375	350		

A= Débit gicleur B= Débit pompe

Débit (kg/h)

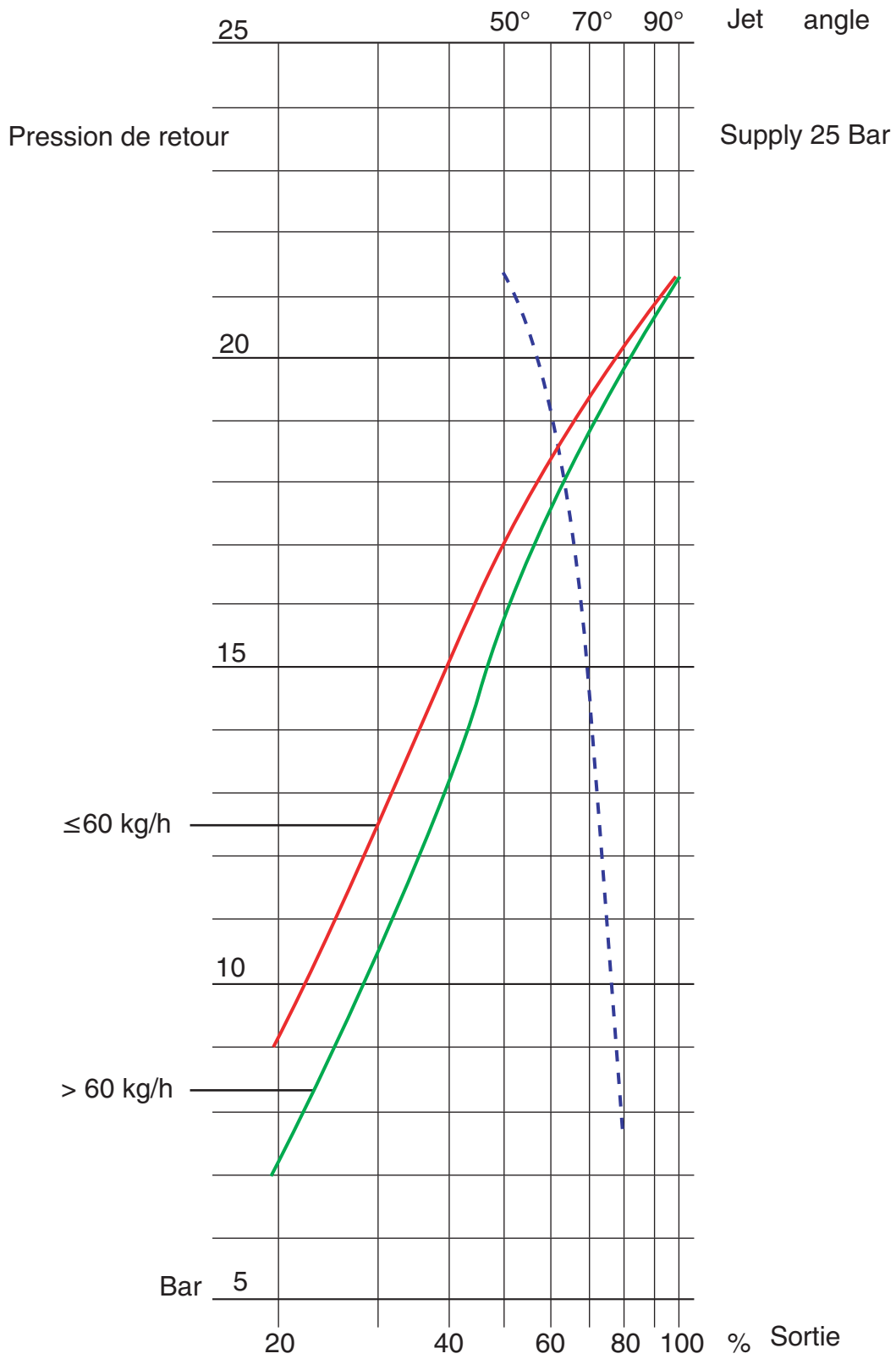
TABLEAU GICLEUR BERGONZO
 Pression pompe (bar)

GPH	Atm	3	4	5	6	7	8	9	10	11	12	13	14	15	16	17	18	19	20	21	22	23	24	25	26	27	28	29	30	
300	A	20	55	58	60	64	65	70	76	85	92	105	118	135	145	175	200	270												
300	B	20	550	535	525	515	500	485	470	450	430	410	380	375	360	330	310	280												
300	A	25	24	25	26	27	28	29	30	31	32	34	35	37	40	43	45	52	60	68	80	95	115							
300	B	25	330	328	325	320	315	307	300	285	280	275	260	250	235	220	190	180	170	168	150	135								
300	A	30	25	26	26	27	28	28	29	30	31	32	33	35	37	38	42	43	46	50	54	60	65	72	80	90	108	130		
300	B	30	370	365	360	355	350	348	345	340	335	328	320	305	300	290	280	270	260	245	240	225	210	190	180	165	150	130		
325	A	20	58	62	65	68	72	78	88	95	110	118	135	150	170	200	240	290												
325	B	20	570	560	550	530	510	500	485	475	450	440	425	400	370	350	330	300												
325	A	25	65	67	69	72	74	75	80	85	90	98	105	115	125	140	160	170	190	225	270	320								
325	B	25	650	643	638	630	628	620	610	600	590	580	565	540	520	500	475	450	425	400	375	350								
325	A	30	68	69	70	71	73	75	78	82	88	92	98	105	110	120	130	140	150	165	180	200	225	250	280	320	360			
325	B	30	720	715	710	705	702	700	690	680	670	655	620	610	600	580	570	550	520	500	480	460	440	420	400	380				
350	A	20	64	68	70	75	80	90	98	105	118	130	145	160	180	210	250	310												
350	B	20	620	600	590	580	570	550	530	500	480	460	440	420	400	375	360	340												
350	A	25	68	69	70	75	80	85	90	98	105	112	120	130	145	160	170	190	210	240	270	300	350							
350	B	25	700	700	690	680	670	660	650	630	610	590	580	550	520	500	480	465	450	430	410	380	360							
350	A	30	68	69	70	73	78	82	88	92	98	105	110	120	128	138	145	160	170	190	210	225	250	275	300	350	375			
350	B	30	790	780	770	760	750	740	720	710	700	690	680	665	650	625	610	590	570	550	520	505	490	475	440	425	400			
375	A	20	72	76	82	88	94	105	115	125	140	155	170	195	225	250	300													
375	B	20	630	615	600	590	580	565	550	520	490	475	450	425	400	375	360													
375	A	25	78	80	85	90	95	100	105	110	120	130	140	155	170	190	200	230	250	280	325	375								
375	B	25	700	690	680	670	660	650	640	625	615	600	580	565	550	520	500	480	460	440	420	400								
375	A	30	90	92	93	95	98	100	105	110	115	120	130	140	150	160	170	180	200	220	240	260	280	320	350	400				
375	B	30	800	790	786	778	770	760	750	730	710	700	690	670	650	630	610	600	590	570	550	530	510	490	470	440				
400	A	20	85	90	98	105	115	125	135	150	165	185	210	240	270	320														
400	B	20	610	605	595	585	575	565	550	520	500	480	460	440	420	400														
400	A	25	85	90	98	104	110	118	125	135	145	155	170	190	200	225	250	280	310	360	400									
400	B	25	710	705	700	695	690	680	670	650	630	610	590	580	560	540	520	500	480	450	425									
400	A	30	100	102	106	110	114	117	120	130	138	148	158	170	180	195	210	230	250	275	300	340	360	400	440					
400	B	30	800	790	786	778	770	760	750	730	710	700	690	670	650	630	610	600	590	570	550	530	510	490	470					
425	A	20	78	80	85	90	95	100	110	120	135	150	170	190	220	250	300	350												
425	B	20	700	690	680	670	650	630	615	600	590	570	530	510	490	450	410	380												
425	A	25	85	88	90	93	95	100	105	110	120	130	140	150	165	180	195	225	250	280	325	380								
425	B	25	750	745	740	730	720	710	700	685	675	665	650	630	610	600	580	560	540	515	490	430								
425	A	30	91	92	94	96	98	99	100	104	110	118	128	138	145	158	168	180	195	210	235	260	280	320	350	400	450			
425	B	30	820	816	812	808	804	800	780	770	760	750	740	730	720	710	695	680	650	625	600	590	570	540	515	490				
450	A	20	86	90	94	98	105	115	125	135	150	170	195	225	250	280	340	380												
450	B	20	700	685	660	645	635	620	605	585	570	545	530	515	490	470	440	410												
450	A	25	92	95	100	105	110	115	120	130	140	150	165	175	190	210	230	260	280	325	375	425								
450	B	25	805	800	790	775	760	745	730	715	700	690	670	650	625	605	580	560	540	520	500	480								
450	A	30	100	102	105	108	111	114	117	120	130	140	150	160	170	180	190	220	240	260	280	310	350	380	425	475				
450	B	30	860	856	850	842	834	826	818	810	790	760	750	740	730	720	700	680	660	640	620	600	580	540	520	500				

Débit (kg/h)

A= Débit gicleur B= Débit pompe

TABLEAU GICLEUR BERGONZO
Pression pompe (bar)

GPH	Atm	3	4	5	6	7	8	9	10	11	12	13	14	15	16	17	18	19	20	21	22	23	24	25	26	27	28	29	30			
475	A	82	88	95	100	110	120	130	145	160	170	195	225	260	300	360																
475	B	800	780	760	740	720	700	680	655	625	600	580	560	520	480	440																
475	A	98	102	108	112	116	120	130	140	150	160	170	180	195	225	250	275	300	350	400	475											
475	B	910	905	900	880	860	840	820	800	780	750	730	710	690	670	650	620	590	560	530	500											
475	A	104	107	110	113	117	120	125	135	145	155	163	170	180	190	200	225	250	275	300	325	360	390	440	480							
475	B	1000	990	975	965	945	930	915	900	890	880	860	840	820	800	780	760	730	700	680	660	640	620	590	460							
500	A	94	102	106	113	120	130	150	170	190	210	230	250	280	325	380																
500	B	800	780	760	740	720	710	680	660	640	610	580	560	520	500	475																
500	A	100	104	108	116	120	130	140	150	160	170	190	210	230	250	270	325	350	400	475												
500	B	900	895	880	865	850	845	830	815	800	780	750	720	700	670	650	620	600	580	550												
500	A	110	113	117	120	125	130	135	140	150	160	170	180	190	220	250	280	250	300	325	350	380	425	480	520							
500	B	1000	990	980	970	960	950	940	925	910	900	880	860	840	820	800	775	750	725	700	775	750	725	600	575							

Débit (kg/h)

A= Débit gicleur B= Débit pompe

MAINTENANCE

CONTROLE ANNUEL

Le contrôle périodique du brûleur (tête de combustion, électrodes, etc.) doit être effectué, par un technicien autorisé, une ou deux fois par an, suivant l'utilisation. Avant de procéder au contrôle pour la maintenance du brûleur, il est souhaitable de contrôler l'état général du brûleur et d'effectuer les opérations suivantes:

- Débrancher le brûleur (enlever la prise). - Fermer le robinet d'arrivée du gaz. - Enlever le couvercle du brûleur, nettoyer le ventilateur et l'aspiration de l'air. - Nettoyer la tête de combustion et contrôler la position des électrodes. - Remonter les pièces.
- Contrôler l'étanchéité des raccords gaz. - Contrôler la cheminée. - Faire redémarrer le brûleur. - Contrôler les paramètres de la combustion (CO₂ = 9,7 (G20); 9,6 (G25); 11,7 (G30); 11,7 (G31), (CO = inférieure à 75 p.p.m.).

AVANT CHAQUE INTERVENTION CONTROLER :

- Qu'il y ait du courant électrique dans l'installation et que le brûleur soit branché.
 - Que la pression du gaz soit correcte et que le robinet d'arrivée du gaz soit ouvert.
 - Que les systèmes de contrôle soient branchés correctement.
- Si toutes ces conditions sont accomplies, faire démarrer le brûleur en appuyant sur le bouton de déblocage.
Contrôle le cycle du brûleur.

LE BRULEUR NE DEMARRE PAS :

- Contrôler l'interrupteur, les thermostats, le moteur, la pression du gaz.
- Interrupteur général en position "0".
- Fusibles cassés.
- Coffret de sécurité défectueux.

LE BRULEUR EFFECTUE LE PREBALAYAGE ET SE BLOQUE A LA FIN DU CYCLE :

- Contrôler la pression de l'air et le ventilateur.
- Contrôler le pressostat de l'air.
- Transformateur défectueux.
- Contrôler le câble d'allumage.
- Electrodes sales, défectueux ou en position erronée.
- Gicleurs bouchés ou consommés.
- Filtres bouchés et pression fuel lourd trop basse.
- Portée d'air de combustion excessivement levée en rapport avec la portée de gicleur.

LE BRULEUR EFFECTUE LA PREBALAYAGE ET NE S'ALLUME PAS :

- Contrôler le montage et la position des électrodes.
- Contrôler le câble d'allumage.
- Contrôler le transformateur d'allumage.
- Contrôler le coffret de sécurité.

LE BRULEUR S'ALLUME ET SE BLOQUE APRES LE TEMPS DE SECURITE :

- Contrôler que la phase et le neutre soient branchés correctement.
- Contrôler l'électrovanne du gaz et fuel lourd.
- Contrôler la position de la photocellule.
- Contrôler le coffret de sécurité.
- Gicleurs bouchés ou consommés.
- La photocellule ne voit pas la flamme.
- Filtres bouchés et pression fuel lourd trop basse.
- Portée d'air de combustion excessivement levée en rapport avec la portée de gicleur.

LE BRULEUR S'ALLUME ET SE BLOQUE APRES QUELQUES MINUTES DE FONCTIONNEMENT :

- Contrôler le régulateur de pression et le filtre du gaz.
- Contrôler la pression du gaz avec un manomètre.
- Contrôler la valeur de détection (min 70 µA).

LE BRULEUR NE PASSE PAS EN GRANDE ALLURE :

- Selettore di Alta e Bassa fiamma sulla morsettiera in posizione errata.
- Coffret de sécurité défectueux.
- Bobine de la vanne fuel lourd défectueux.
- Pression fuel lourd trop basse.
- Filtres bouchés.
- Gicleurs bouchés ou consommés.
- Servomoteur défectueux ou en position erronée.

Índice

ES

1 - Características técnicas

- Características técnicasp.54
- Dimensiones globalesp.54

2 - Instalación

- Conexión eléctricap.55
- Conexión a la redp.55

3 - Arrancador y regulaciones gas

- Funcionamiento del quemadorp.55
- Regulación de la combustiónp.55
- Ciclos de funcionamiento del equipop.56
- Regulaciones aire / gasp.56,57
- Regulaciones cabeza / presostatip.58
- Comprobación equipo de detección de llamap.58
- Desmontaje della cabeza de combustionp.59

4 - Arrancador y regulaciones fuel pesado

- Conexión de fuel pesadop.59
- Comprobacionesp.59
- Funcionamiento del quemadorp.60
- Regulacionesp.60
- Sistema hidráulicop.61,62
- Posición de los electrodos y limpiezap.63
- Prospecto inyectorsp.64,65,66,67,68

5 - Uso y mantenimiento

- Anomalías de funcionamientop.69

CARACTERISTICAS TECNICAS

MODELO		Multiflam 700.1	Multiflam 800.1	Multiflam 1000.1	Multiflam 1200.1
Potencia térmica máx.	kW	7.500	8.500	10.500	13.000
	kcal/h	6.465.000	7.327.500	9.052.000	11.207.000
Potencia térmica min.	kW	1.500	2.000	2.500	2.700
	kcal/h	1.290.000	1.724.000	2.155.000	2.327.600
Presión Natural gas	mbar	60±700	85±700	115±700	160±700
Presión LPG	mbar	125±700	185±700	110±700	160±700
Alimentación eléctrica 50 Hz	V	230/400	230/400	230/400	230/400
Combustible :	Natural Gas (L.C.V. 8.570 kcal/Nm³), LPG (L.C.V. 22.260 kcal/Nm³) Fuel Pesado (L.C.V. 9.800 kcal/kg max. visc 50°E at 50°C)				

DIMENSIONES TOTALES

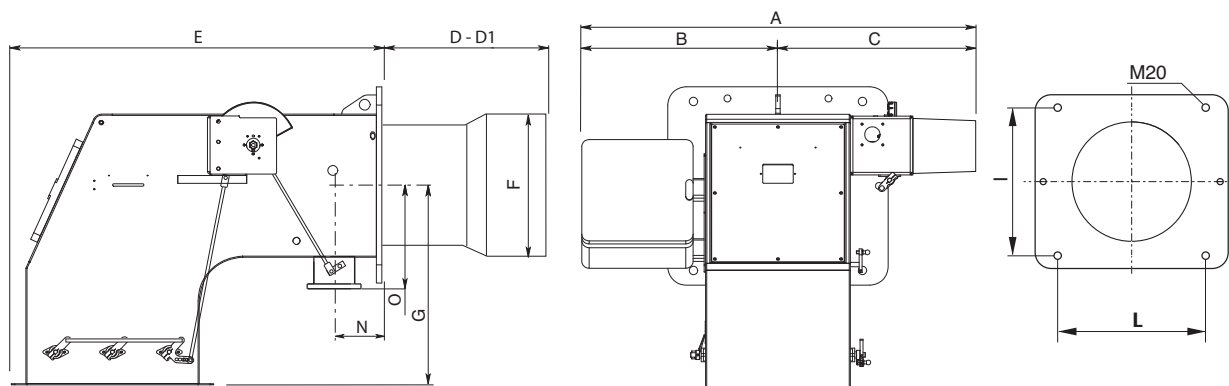

D = cabeza corta D1 = cabeza larga Dimensiones (mm)

MODELO	A	B	C	D	D1	E	F	G	I	L	M	N	O
Multiflam 700.1 TS	1170	540	630	470	-	1030	420	550	460	460	M20	195	232
Multiflam 800.1 TS	1170	540	630	470	-	1030	420	550	460	460	M20	195	232
Multiflam 1000.1 TS	1170	540	630	470	-	1030	420	550	460	460	M20	195	232
Multiflam 1200.1 TS	1170	540	630	470	-	1030	450	550	460	460	M20	195	232

BRIDE AIRE

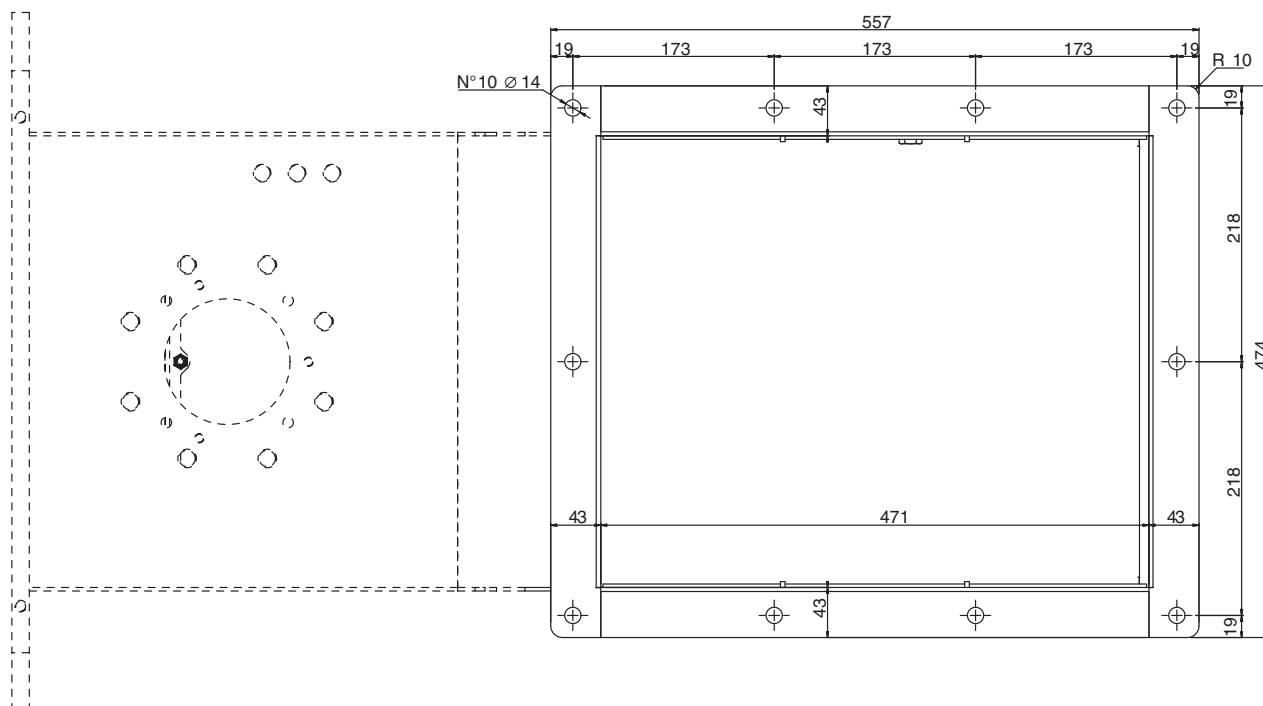

CONEXIÓN ELÉCTRICA

Todos los quemadores están ensayados a 400V/50Hz trifásico para los motores, y 230V/50Hz monofásico con neutro para los auxiliares. Si fuese necesario alimentar el quemador con 230V trifásico sin neutro, provéase a las modificaciones necesarias con referencia al esquema específico del quemador y averiguar que el relé térmico esté dentro del campo de absorción del motor. Averiguar también el sentido de rotación del motor del ventilador.

CONEXIÓN A LA RED

Después de haber conectado el quemador a la tubería del gas, es necesario averiguar si esta última está perfectamente estanca. Averiguar también que la chimenea no esté obstruida. Abrir la válvula de corte, purgar cuidadosamente la tubería al través de la toma de presión y luego controlar el valor de la presión con un manómetro apropiado. Suministrar tensión a la instalación y regular los termostatos a la temperatura que se desea. Cuando cierran los termostatos, el equipo de control de estancación efectúa un ensayo de estancación de las válvulas; al término de la prueba el quemador recibe el consentimiento para efectuar el ciclo de puesta en marcha.

PUESTA EN MARCHA DEL QUEMADOR

Antes de poner en marcha el quemador, averiguar que el mismo sea instalado correctamente. Controlar también las conexiones eléctricas con referencia a los esquemas y a la tubería de la instalación. Antes de efectuar la conexión eléctrica, comprobar que el voltaje corresponda a los datos indicados por la tarjeta de las características. El esquema de conexión eléctrica y el ciclo de arranque son ilustrados a parte. Para conectar el equipo de control al quemador véase el esquema relativo. Prestar particular atención a la conexión del neutro y de la fase, que no se deben nunca invertir. Averiguar también la conexión de tierra de la instalación. Con los motores trifásicos controlar el sentido de rotación del motor (véase la flecha). Purgar el aire y las impurezas de la tubería del gas. Comprobar que la presión del gas sea dentro de los límites indicados por la tarjeta. Este control tiene que ser efectuado con un manómetro de gas conectado a la apropiada toma de presión del quemador. El motor arranque y empieza el prebarrido. El motorreductor abre el cierre del aire a la abertura máxima en cerca de 30 segundos. Cuando el motorreductor está completamente abierto, un señal al equipo de control empieza un ciclo de prebarrido de 66 segundos (36 sec. LFL1.333) aproximadamente. Al término del prebarrido, el motorreductor lleva el cierre del aire en posición de baja llama, permitiendo el encendido del quemador al caudal mínimo. Al mismo tiempo, el transformador de encendido viene alimentado y después de 3 segundos (pre-encendido) son alimentadas las válvulas del gas. En este punto, la válvula de mariposa regula el caudal del gas en la cabeza de combustión. Dos segundos después de la abertura de las válvulas, el transformador viene excluido del circuito. - En caso de falta de encendido, el quemador se pone en seguridad dentro de 2 segundos. - El quemador está en marcha a la potencia mínima (cerca del 30% de la potencia máxima). El equipo modulante mandará la abertura del servomotor a la potencia máxima, o bien lo bloqueará a la potencia intermedia necesitada por la instalación. La abertura del servomotor provocará la abertura de gas y aire de manera proporcional, para haber una combustión siempre optimal por todos los caudales (30%÷100%).

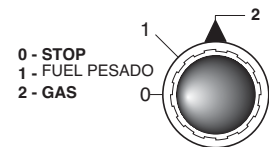

REGULACIÓN DE LA COMBUSTIÓN

CUIDADO: para obtener una correcta regulación de la combustión y de la potencia térmica nominal se necesita efectuar una análisis de los humos con una apropiada instrumentación. La regulación de la combustión y de la potencia debe ser efectuada contemporáneamente a una análisis de los productos de la combustión, asegurándose que los valores averiguados sean correctos y, de toda manera, que correspondan a las normas vigentes de seguridad.

ESTA OPERACIÓN TIENE QUE SER EFECTUADA POR TECNICOS PROFESIONALMENTE CALIFICADOS Y AUTORIZADOS POR ECOFLAM BRUCIATORI S.P.A.

CICLOS DE FUNCIONAMIENTO DEL EQUIPO LANDIS & STAEFA MOD. LFL1.622-LFL1.333

ES

Ref.	Descripción	Duración
t1	Tiempo de espera de la confirmación presión del aire	8"
t2	Tiempo de prebarrido	66"(36")
t3	Tiempo de seguridad	2"
t4	Tiempo de pre-encendido	4"
t5	Tiempo para el consentimiento de funcionamiento de la válvula de trabajo del combustible a la potencia mínima.	10"
t6	Tiempo para el consentimiento de funcionamiento de la válvula de trabajo del combustible a la potencia mínima.	10"

El equipo de control de llama pone en marcha el quemador para efectuar el prebarrido de la cámara de combustión, controlando la presión del aire de ventilación por medio del presóstato del aire. Al término del prebarrido se activa el transformador de encendido, generando

una chispa entre los electrodos y al mismo tiempo se abren las válvulas del gas (válvula de seguridad VS y válvula de trabajo VL). La seguridad total, en caso de falta de encendido o de apagado accidental está confiada a una sonda de detección que activa la puesta en seguridad de la instalación dentro del tiempo de seguridad. En caso de falta de gas o de una notable bajada de presión, el presóstato gas de mínima provee a cortar el funcionamiento del quemador.

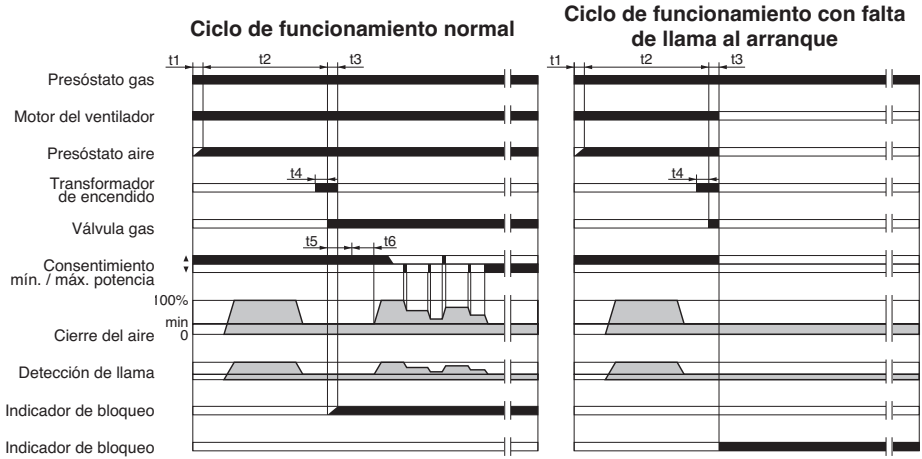

SERVOMOTOR DEL CIERRE DEL AIRE LANDIS & STAEFA SQM 50.481A2

Remover la tapa para acceder a las levas de regulación. La regulación de las levas tiene que ser efectuada con su apropiada llave de suministro. Descripción:



- I - Leva de regulación abertura del cierre del aire en la potencia máx. (GAS-FUEL PESADO).
- II - Leva de regulación de la posición del cierre al apagado (cierre).
- III - Leva de regulación aire salida a GAS.
- IV - Leva de regulación aire salida a FUEL PESADO.
- V - Leva de regulación abertura del cierre del aire en la Baja Llama (GAS).
- VI - Leva de regulación abertura del cierre del aire en la Baja Llama (FUEL PESADO).
- VII - Leva de regulación abertura del cierre del aire en la Alta Llama(GAS).
- VIII - No utilizar.

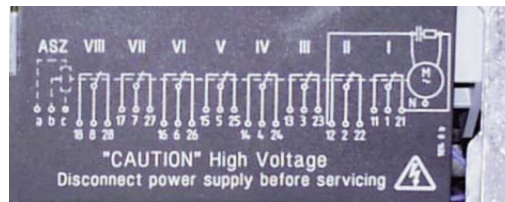

CALCULO DE LA POTENCIA DE FUNCIONAMIENTO DEL QUEMADOR

Para calcular la potencia de funcionamiento, en kW, del quemador, proceder de la manera siguiente : Comprobar al contador la cantidad de litros suministrados y la duración, en segundos, de la lectura, luego proceder al calculo de la potencia con la formula siguiente:

$$\frac{e}{s} \times f = kW$$

- f { G20 = 34,02
- G25 = 29,25
- G30 = 116
- G31 = 88

e = Litros de gas
s = Tiempo en segundos

REGULACIÓN DEL CAUDAL DE AIRE Y GAS

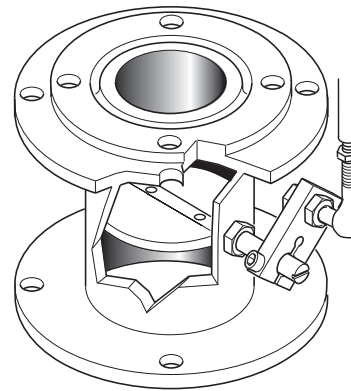
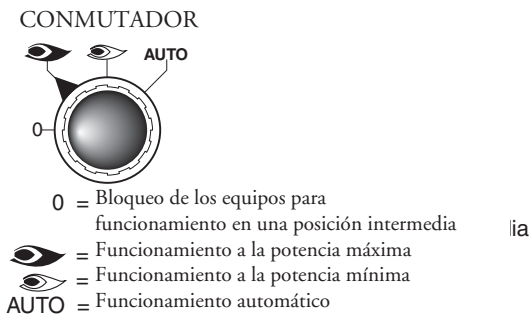
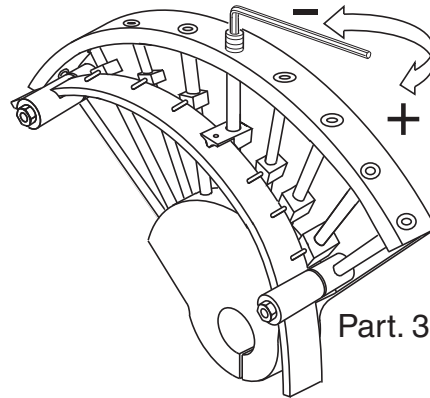
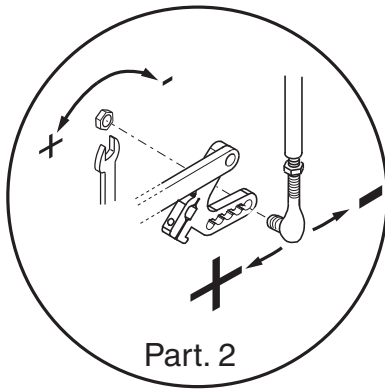

REGULACIÓN DE LA POTENCIA MÍNIMA DEL GAS

Posicionar el conmutador colocado sobre el cuadro de mandos a la posición 2 y proceder como sigue:
 Para regular el caudal mínimo de gas proceder con la llave hexagonal sobre el tornillo de la biela y modificar el ángulo de la clapeta de gas de la válvula de mariposa

REGULACIÓN DE LA POTENCIA MÁXIMA DE GAS

Posicionar el conmutador colocado sobre el cuadro de mandos a la posición 1 y proceder como sigue:
 Para regular el caudal máximo de gas proceder sobre la electroválvula de regulación hasta obtener el valor correcto para la caldera.

REGULACIÓN DEL CAUDAL MÁXIMO DE AIRE

Aflojar el tornillo de fijación del asta y posicionar la misma en la posición correcta.
 Al final de la regulación volver a cerrar el tornillo del asta.

REGULACIÓN DEL CAUDAL INTERMEDIO DE GAS

Accionar el servomotor con el conmutador (abierto/cerrado) y ponerlo en la posición 0 para bloquear la carrera.
 Para la regulación proceder como sigue:
 Repetir los mismos pasos para los otros puntos del excéntrico.
 Regulación de los caudales intermedios de gas (véase la ilustración parte 3):
 Con una llave hexagonal modificar la posición de la hoja de guía del excéntrico, atornillando se aumenta el caudal, destornillando se disminuye

REGULACIÓN DE LA COMBUSTIÓN

CUIDADO: para obtener una correcta regulación de la combustión y del caudal térmico, estos tienen que ser hechos conjuntamente a una análisis de la combustión, a efectuarse por medio de instrumentos apropiados, comprobando que los datos sean correctos y se conformen a las normas de seguridad locales. Las operaciones de regulación tienen que ser efectuadas por técnicos expertos y calificados, autorizados por Ecoflam Bruciatori S.p.A.

REGULACION CABEZA DE COMBUSTION

ES

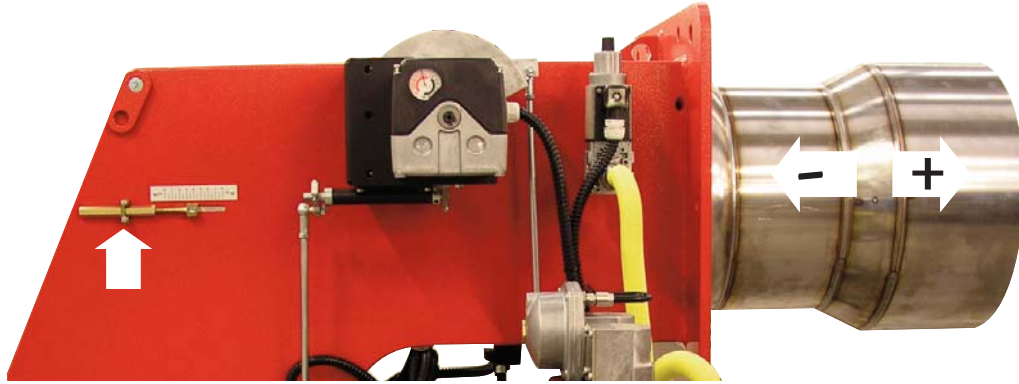

REGLAJE DEL PRESOSTATO GAS DE MÍNIMA PRESIÓN

Destornillar y quitar la tapa M. - Posicionar el regulador N a un valor igual al 60% de la presión nominal de alimentación el gas (ej. para gas nat. con pres. nom. de alim. de 20 mbar, regulador regulado al valor de 12 mbar; para G.P.L. con pres. nom. de alim. G30-G31 30/37 mbar, regulador regulado al valor 18). - Remontar la tapa M y fijarla

REGULACIÓN DEL PRESOSTATO DEL AIRE

Destornillar los tornillos A y B y quitar la tapa. Regular el presostato del aire al mínimo rodando el regulador en la posición 1. Arrancar el quemador en baja llama y comprobar que la combustión sea correcta. Por medio de una tarjeta, obstruir progresivamente el conducto de aspiración del aire, hasta obtener un aumento de CO₂ del 0,5÷0,8% o bien, al disponer de un manómetro conectado a la toma de presión E, hasta obtener una caída de presión de 1 mbar (10 mm C.A.). Aumentar progresivamente el valor de la regulación del presostato hasta que el quemador se para en seguridad. Quitar la obstrucción y atornillar la tapa, luego arrancar el quemador presionando el botón de rearme del equipo de control.

Nota: La presión medida a la toma del aire E debe estar dentro de los límites del campo de trabajo del presostato. En caso contrario, destornillar la tuerca de bloqueo del tornillo F y rodarlo progresivamente: a la derecha para disminuir la presión; a la izquierda para aumentarla. Al final atornillar la tuerca de bloqueo.

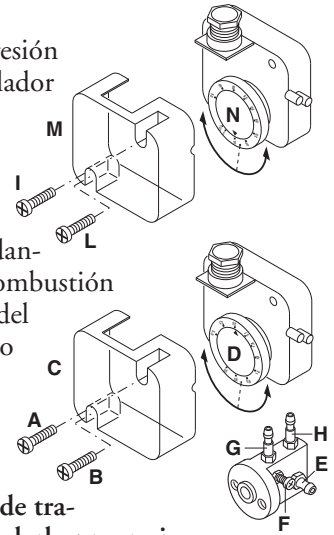

COMPROBACIÓN EQUIPO DE DETECCIÓN DE LLAMA

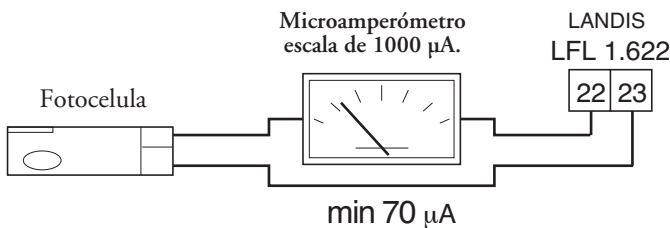

El control de la corriente de detección de llama se efectúa conectando un microamperímetro de escala de 1000 µA (corriente continua) en serie la fotocelula. Normalmente, el valor de la corriente de detección de llama es >70 µA.

DESMONTAJE DEL TUBO DE LLAMA

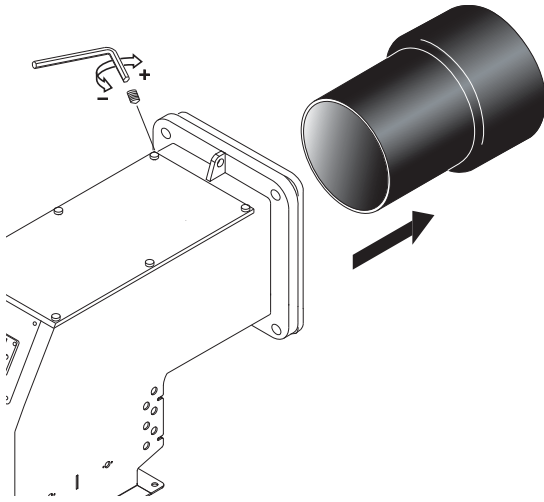

DESMONTAJE DELLA CABEZA DE COMBUSTION

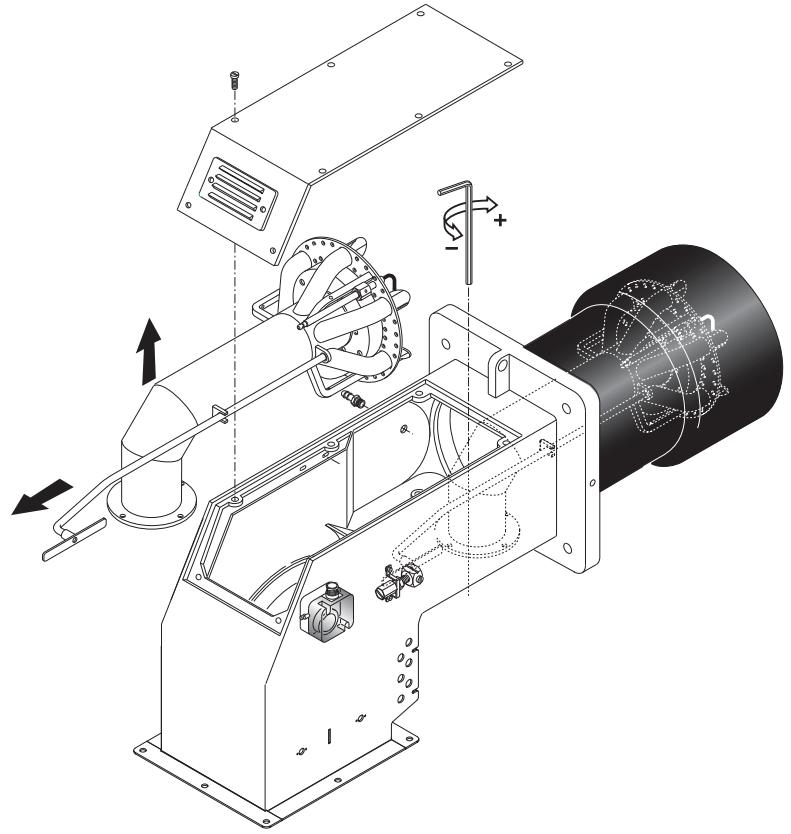

CONEXIÓN FUEL PESADO A LA QUEMADOR



COMPROBACIONES A EFECTUAR PARA UNA CORRECTA INSTALACIÓN:

Antes de proceder con el relleno del circuito de alimentación y relativa puesta en marcha del quemador, sería aconsejable efectuar los controles siguientes:

- La línea de alimentación debe ser adecuada a la carga absorbida por la instalación
- Los fusibles deben ser adecuados a la carga absorbida por la instalación
- Los termostatos de caldera tienen que ser correctamente conectados
- Voltaje y frecuencia deben estar en los límites especificados
- El tipo de combustible debe ser lo especificado por el fabricante del quemador
- La sección de la tubería de alimentación debe ser adecuada al caudal de fuel necesitado
- Los filtros , grifos y empalmes deben ser instalados correctamente
- La longitud del tubo de llama debe ser la especificada por el fabricante de la caldera
- El caudal de los inyectores debe ser proporcionado a la potencia de la caldera

ES

FUNCIONAMIENTO DEL QUEMADOR

Con el quemador en la posición start y los termostatos caldera habilitados, las resistencias (G) del precalentador, las resistencias auxiliares en la bomba y el grupo cabeza están bajo tensión. Cuando el termostato del precalentador alcanza el valor fijado (habitualmente es necesario un mínimo de 90°C para garantizar un buen nivel de circulación) la bomba de arranque está habilitada (si se utiliza el dispositivo de termostato GEFRAN 200 regular el set point en la salida 1).

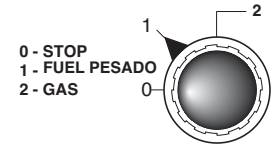

Si el sistema de precalentamiento del depósito también está equipado para un cambiador de líquidos (agua caliente, vapor y aceite diatérmico) el termostato puede habilitar un contacto en el tablero de bornes para cualquier asenso eléctrico de la electroválvula para líquidos. Ésta no es una solución estándar, ya que el fluido calentado normalmente está siempre en circulación. La bomba empieza a enviar el aceite (la cabeza ya ha sido calentada por su resistencia (O) y, por lo tanto, no hay ningún residuo de aceite espeso frío) que fluye del depósito a la cabeza y luego a la línea de retorno del anillo de alimentación del aceite. Cuando el termostato de la cabeza alcanza el valor fijado (habitualmente unos 70-30°C) el ciclo empieza de manera apropiada y el aparato da el asenso al arranque del quemador. El servomotor se sitúa automáticamente en el mínimo (véase el capítulo de la regulación) actuando sobre la compuerta del aire y el retorno del regulador de presión para el aceite combustible.

El electroimán (A) abre la boquilla (Q) en la siguiente condición:

- las chispas de los electrodos de encendido son producidas por el transformador que también se regula automáticamente mediante el dispositivo de control del quemador.

Si la célula de detección no detecta la llama, el quemador se bloquea.

Una vez que se haya encendido y después del periodo de estabilización de la llama, el sistema empieza a funcionar en modulación.

- Antes del arranque asegurarse de que la bomba y los tubos de impulsión estén completamente llenos de aceite combustible caliente; la ausencia de aceite combustible puede causar el agarrotamiento de la bomba.

- Si hay un bloqueo, una luz específica de aviso en el programador y en el panel frontal de control del quemador se enciende y esta señal se envía habitualmente al aparato principal que el quemador utiliza, activando una alarma acústica y una luz de aviso.

- Algunos bloqueos son normales durante el primer arranque (hasta 4 aproximadamente); para desbloquear el sistema, pulsar la tecla del aparato (situada en la parte delantera del panel de control del quemador) para repetir el ciclo de arranque. Si el problema persiste dirigirse a un técnico especializado.

N.B. La posición del aparato en el momento del bloqueo indica sus posibles causas.

REGULACIÓN DE LA PRESIÓN DEL RETORNO DE FUEL PESADO

El diagrama ilustra el sistema de regulación del retorno de fuel pesado para estos tipos de quemadores, los cuales han incorporado un inyector con retorno variable progresivo. El caudal del fuel pesado puede variarse a través del inyector de retorno, cambiando la presión en el retorno. El caudal máxima de fuel pesado se obtiene, cuando la presión de la bomba es de unos 30 bar y el retorno está completamente cerrado. El caudal mínimo del fuel pesado se obtiene cuando la línea de retorno está completamente abierta. La presión en impulsión se lee, montando un manómetro en la bomba. La presión del retorno se lee en el manómetro montado a continuación del quemador en el regulador de presión.

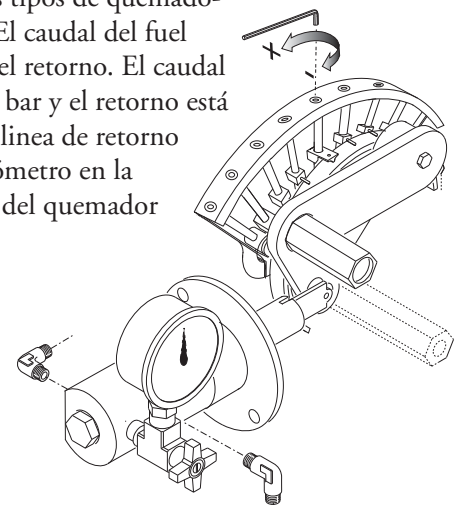

Presión bomba 22-30 bar.

Max. caudal , presión de retorno:

FLUIDICS inyector : 16 ÷ 19 bar.

BERGONZO inyector : 20 ÷ 24 bar.

Min. caudal , presión de retorno :

FLUIDICS inyector : 6 ÷ 9 bar

BERGONZO inyector : 4 ÷ 8 bar

FASE DE PREBARRIDO

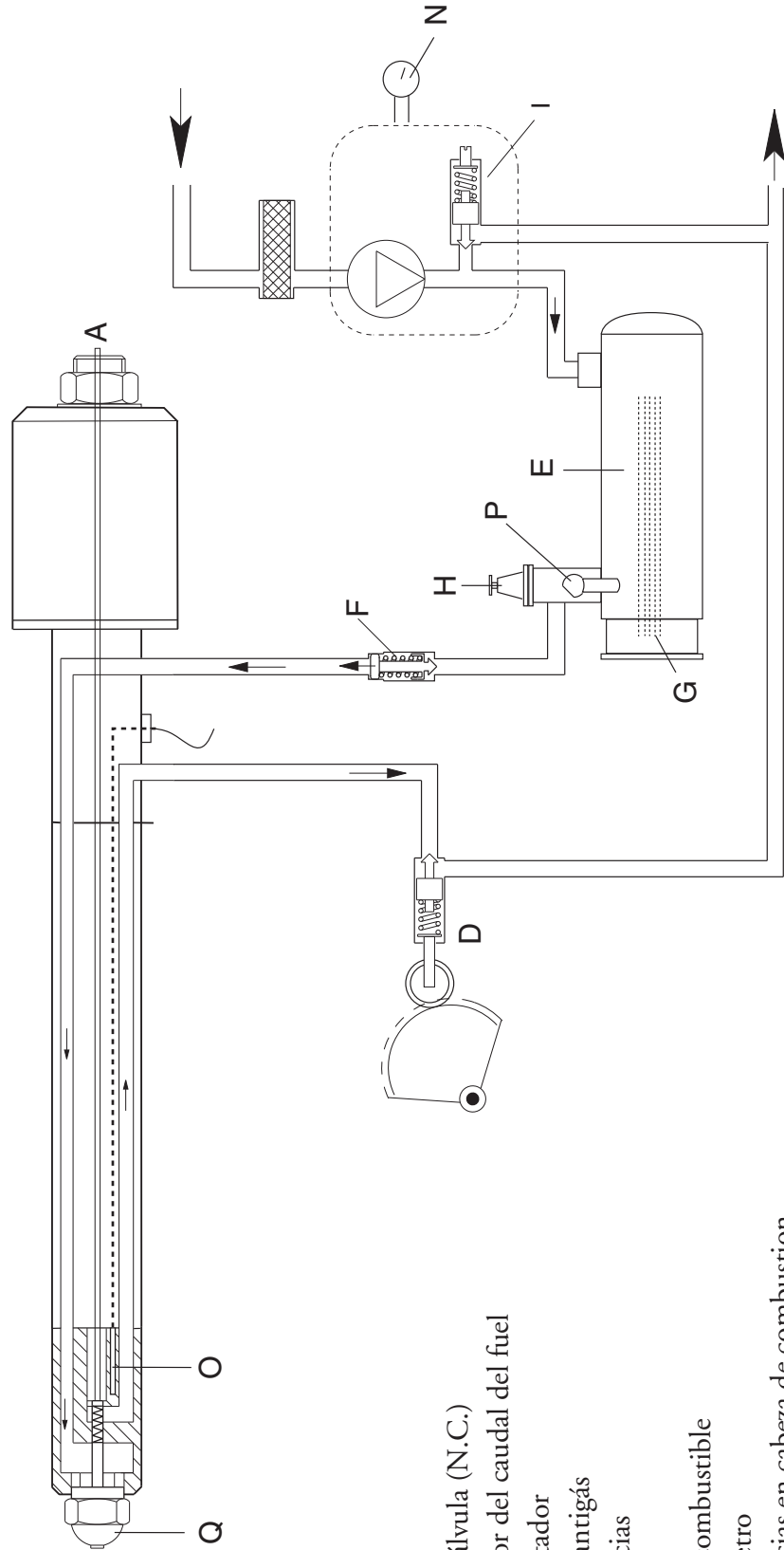

LEYENDA :

- A Electroválvula (N.C.)
- D Regulador del caudal del fuel
- E Precalentador
- F Válvula antigás
- G Resistencias
- H Filtro
- I Bomba combustible
- N Manometro
- O Resistencias en cabeza de combustion
- P Oil temperature sensor
- Q Inyector

FASE DE PREBARRIDO

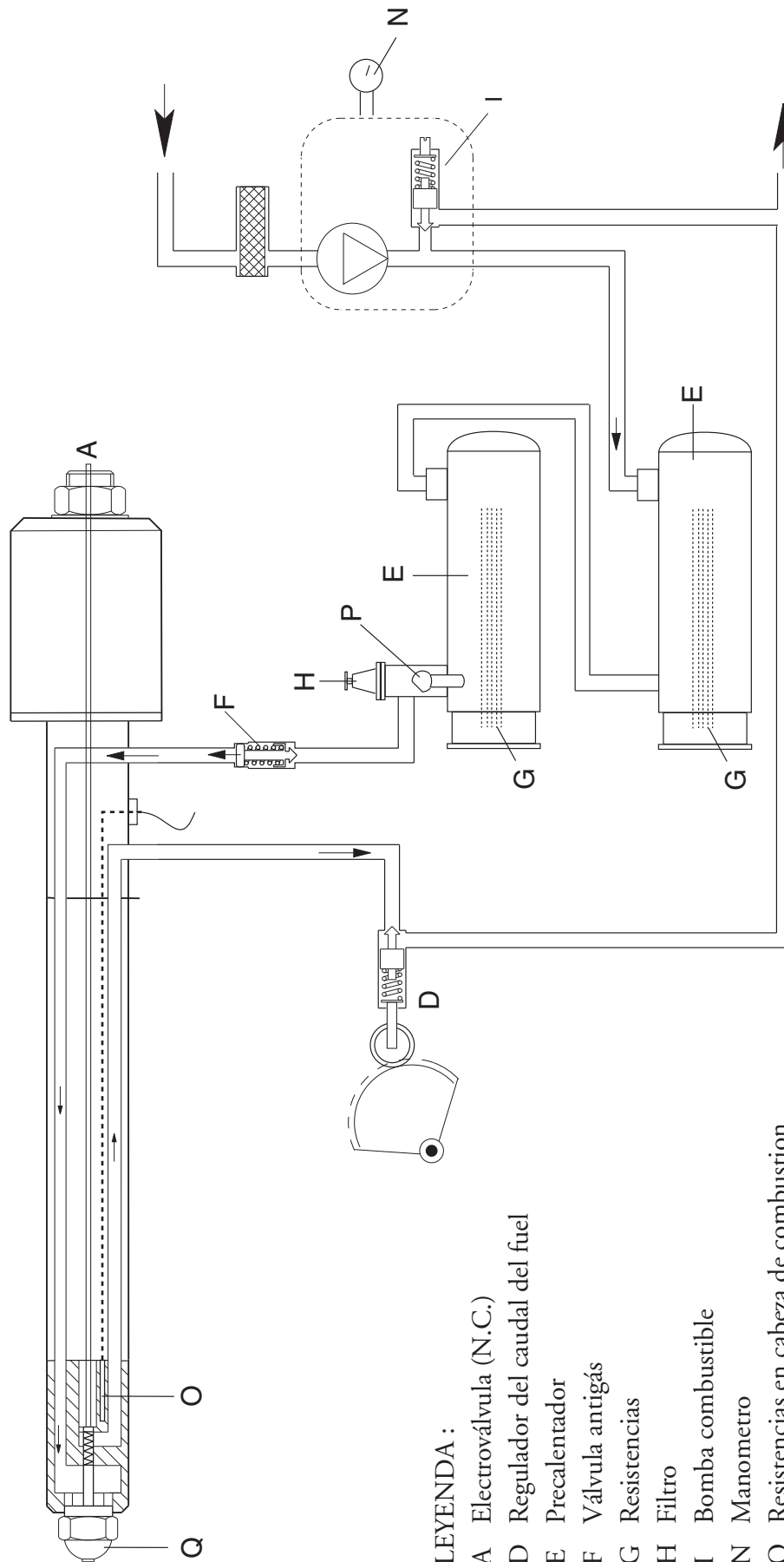

LEYENDA :

- A Electroválvula (N.C.)
- D Regulador del caudal del fuel
- E Precalentador
- F Válvula antigás
- G Resistencias
- H Filtro
- I Bomba combustible
- N Manometro
- O Resistencias en cabeza de combustion
- P Oil temperature sensor
- Q Inyector

POSICIÓN DE LOS ELECTRODOS

ES

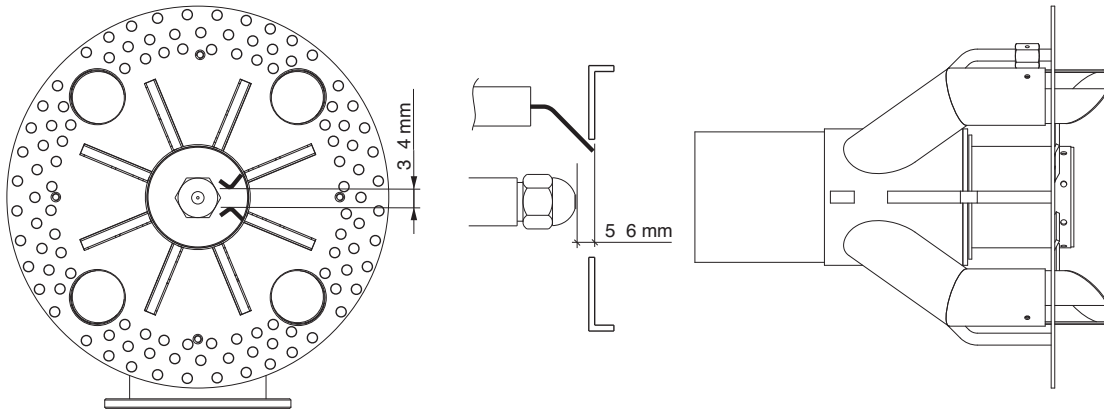

LIMPIEZA Y SOSTITUCIÓN DEL INYECTOR

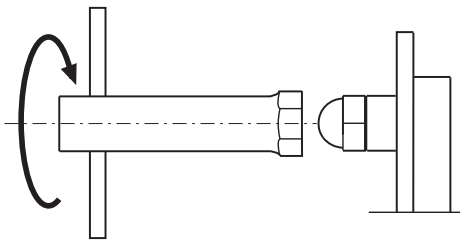

Utilizar solamente la llave de suministro para desmontar el inyector, teniendo cuidado de no estropear los electrodos. Montar el nuevo inyector con el mismo cuidado. Nota: Comprobar todavía la posición de los electrodos después del montaje (ver a la ilustración). Una posición errada puede originar problemas de encendido.

INYEKTOR FLUIDICS

ES

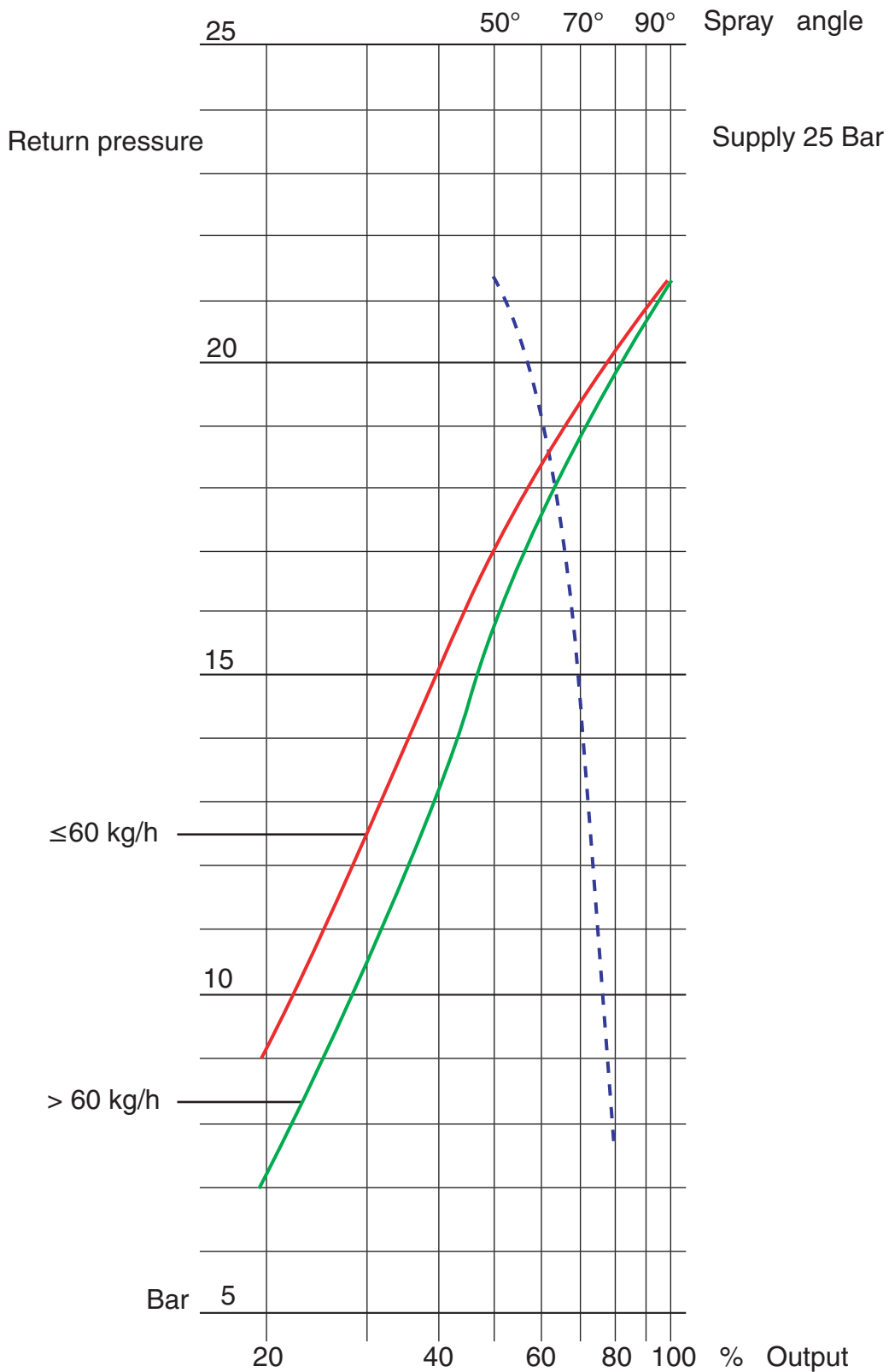

PROSPECTO INYECTORES BERGONZO

Presión bomba (bar)

GPH	Atm	3	4	5	6	7	8	9	10	11	12	13	14	15	16	17	18	19	20	21	22	23	24	25	26	27	28	29	30
125	A	20	22	23	25	26	27	29	32	34	37	40	44	50	57	65	77	95											
125	B	20	285	280	275	274	272	271	245	235	220	205	190	175	160	145	130	115											
125	A	25	24	25	26	27	28	29	30	31	32	34	35	37	40	43	45	52	60	68	80	95	115						
125	B	25	330	328	325	320	315	307	300	285	280	275	260	250	235	220	190	180	170	168	150	135							
125	A	30	25	26	26	27	28	28	29	30	31	32	33	35	37	38	42	43	46	50	54	60	65	72	80	90	108	130	
125	B	30	370	365	360	355	350	348	345	340	335	328	320	305	300	290	280	270	260	245	240	225	210	190	180	165	150	130	
150	A	20	30	33	34	35	37	39	43	46	50	55	60	68	75	85	100	120											
150	B	20	325	320	315	308	300	290	285	275	260	250	240	220	190	180	160	140											
150	A	25	32	33	34	35	37	37	38	42	45	47	50	55	60	65	70	78	83	94	110	120	150						
150	B	25	375	370	365	363	358	355	350	345	330	320	310	300	285	275	260	250	240	220	195	180	150						
150	A	30	35	36	36	37	37	37	39	41	42	45	46	48	50	54	58	62	65	70	75	80	88	95	110	120	140	180	
150	B	30	420	420	415	410	405	400	395	390	380	375	365	350	345	340	320	300	290	280	270	250	240	220	200	180			
175	A	20	35	37	39	42	44	46	48	55	58	62	68	75	84	95	118	155											
175	B	20	350	350	349	348	330	325	315	300	290	280	265	248	225	195	175	155											
175	A	25	35	36	37	41	42	44	45	47	50	52	58	62	65	70	78	88	95	110	120	140	170						
175	B	25	395	390	385	382	380	378	370	360	350	348	330	325	315	300	280	275	260	240	225	200	170						
175	A	30	42	43	44	45	46	47	48	50	52	55	58	60	62	65	70	72	78	85	90	100	110	118	135	158	190		
175	B	30	440	440	435	430	425	420	415	410	408	400	390	380	370	360	350	330	320	300	285	275	260	250	235	220	190		
200	A	20	38	40	42	44	47	50	55	60	65	70	80	90	100	120	140	170											
200	B	20	400	398	388	380	370	360	350	340	330	320	300	280	275	250	230	210											
200	A	25	42	43	43	44	45	47	50	52	55	60	65	70	78	85	95	105	115	130	150	170	220						
200	B	25	450	448	448	445	440	430	425	412	405	400	390	380	375	360	345	325	315	290	280	260	220						
200	A	30	48	49	50	51	52	53	55	56	58	60	62	64	68	70	75	80	85	92	100	110	120	130	150	175	200		
200	B	30	500	500	495	490	485	480	475	470	460	450	440	430	420	410	395	385	375	350	340	325	315	300	290	275	260		
225	A	20	42	43	45	47	48	52	56	60	65	70	80	90	100	115	140	180											
225	B	20	420	410	405	400	395	380	375	365	350	345	335	320	300	280	265	250											
225	A	25	45	46	47	48	50	52	55	58	60	63	68	73	80	90	98	108	120	140	160	180	225						
225	B	25	475	468	460	455	450	445	437	425	410	400	380	375	360	350	340	315	300	280	260	240							
225	A	30	50	50	51	52	52	53	54	55	57	60	62	66	68	75	80	88	94	100	110	120	130	140	155	175	200	240	
225	B	30	510	510	505	503	500	495	490	480	460	460	440	430	420	410	400	390	380	370	360	350	340	325	310	300	285	275	
250	A	20	42	44	46	47	50	55	60	65	70	80	90	100	115	140	160	220											
250	B	20	425	415	408	403	400	380	375	365	350	338	325	300	280	265	250	240											
250	A	25	46	47	49	50	52	55	58	60	63	66	72	78	85	92	100	110	130	140	165	200							
250	B	25	480	475	475	470	465	450	445	440	425	410	400	380	375	355	340	330	310	300	280	275							
250	A	30	52	52	52	53	54	55	58	60	62	65	68	72	78	82	90	95	105	105	125	135	150	165	180	220	260		
250	B	30	520	515	515	510	510	505	500	490	480	475	460	450	440	430	420	400	380	370	360	350	340	325	310	300	285	275	
275	A	20	52	53	55	58	60	63	68	75	80	90	100	115	125	150	170	225											
275	B	20	540	530	520	510	500	490	475	450	440	420	400	375	350	325	300	275											
275	A	25	55	56	57	58	60	64	68	70	75	80	85	95	100	115	125	135	150	170	190	225	265						
275	B	25	600	600	595	590	580	570	560	550	540	525	510	500	480	460	440	425	400	375	350	325	300						
275	A	30	60	61	62	63	64	65	66	67	70	74	78	82	88	95	100	110	118	125	135	150	165	180	200	240	275		
275	B	30	680	675	668	662	658	650	640	630	620	610	600	590	580	565	555	545	525	500	480	460	440	425	400	375	350		

B= caudal de bomba

A= caudal de inyector

Caudal (kg/h)

PROSPECTO INYECTORES BERGONZO
Presión bomba (bar)

vcGPH	Atm	3	4	5	6	7	8	9	10	11	12	13	14	15	16	17	18	19	20	21	22	23	24	25	26	27	28	29	30
300	A	20	55	58	60	64	65	70	76	85	92	105	118	135	145	175	200	270											
300	B	20	550	535	525	515	500	485	470	450	430	410	380	375	360	330	310	280											
300	A	25	24	25	26	27	28	29	30	31	32	34	35	37	40	43	45	52	60	68	80	95	115						
300	B	25	330	328	325	320	315	307	300	285	280	275	260	250	235	220	190	180	170	168	150	135							
300	A	30	25	26	26	27	28	28	29	30	31	32	33	35	37	38	42	43	46	50	54	60	65	72	80	90	108	130	
300	B	30	370	365	360	355	350	348	345	340	335	328	320	305	300	290	280	270	260	245	240	225	210	190	180	165	150	130	
325	A	20	58	62	65	68	72	78	88	95	110	118	135	150	170	200	240	290											
325	B	20	570	560	550	530	510	500	485	475	450	440	425	400	370	350	330	300											
325	A	25	65	67	69	72	74	75	80	85	90	98	105	115	125	140	160	170	190	225	270	320							
325	B	25	650	643	638	630	628	620	610	600	590	580	565	540	520	500	475	450	425	400	375	350							
325	A	30	68	69	70	71	73	75	78	82	88	92	98	105	110	120	130	140	150	165	180	200	225	250	280	320	360		
325	B	30	720	715	710	705	702	700	690	680	670	655	620	610	600	580	570	550	520	500	480	460	440	420	400	380			
350	A	20	64	68	70	75	80	90	98	105	118	130	145	160	180	210	250	310											
350	B	20	620	600	590	580	570	550	530	500	480	460	440	420	400	375	360	340											
350	A	25	68	69	70	75	80	85	90	98	105	112	120	130	145	160	170	190	210	240	270	300	350						
350	B	25	700	700	690	680	670	660	650	630	610	590	580	550	520	500	480	465	450	430	410	380	360						
350	A	30	68	69	70	73	78	82	88	92	98	105	110	120	128	138	145	160	170	190	210	225	250	275	300	350	375		
350	B	30	790	780	770	760	750	740	720	710	700	690	680	665	650	625	610	590	570	550	520	505	490	475	440	425	400		
375	A	20	72	76	82	88	94	105	115	125	140	155	170	195	225	250	300												
375	B	20	630	615	600	590	580	565	550	520	490	475	450	425	400	375	360												
375	A	25	78	80	85	90	95	100	105	110	120	130	140	155	170	190	200	230	250	280	325	375							
375	B	25	700	690	680	670	660	650	640	625	615	600	580	565	550	520	500	480	460	440	420	400							
375	A	30	90	92	93	95	98	100	105	110	115	120	130	140	150	160	170	180	200	220	240	260	280	320	350	400			
375	B	30	800	790	786	778	770	760	750	730	710	700	690	670	650	630	610	600	590	570	550	530	510	490	470	440			
400	A	20	85	90	98	105	115	125	135	150	165	185	210	240	270	320													
400	B	20	610	605	595	585	575	565	550	520	500	480	460	440	420	400													
400	A	25	85	90	98	104	110	118	125	135	145	155	170	190	200	225	250	280	310	360	400								
400	B	25	710	705	700	695	690	680	670	650	630	610	590	580	560	540	520	500	480	450	425								
400	A	30	100	102	106	110	114	117	120	130	138	148	158	170	180	195	210	230	250	275	300	340	360	400	440				
400	B	30	800	790	786	778	770	760	750	730	710	700	690	670	650	630	610	600	590	570	550	530	510	490	470				
425	A	20	78	80	85	90	95	100	110	120	135	150	170	190	220	250	300	350											
425	B	20	700	690	680	670	650	630	615	600	590	570	530	510	490	450	410	380											
425	A	25	85	88	90	93	95	100	105	110	120	130	140	150	165	180	195	225	250	280	325	380							
425	B	25	750	745	740	730	720	710	700	685	675	665	650	630	610	600	580	560	540	515	490	430							
425	A	30	91	92	94	96	98	99	100	104	110	118	128	138	145	158	168	180	195	210	235	260	280	320	350	400	450		
425	B	30	820	816	812	808	804	800	780	770	760	750	740	730	720	710	695	680	650	625	600	590	570	540	515	490			
450	A	20	86	90	94	98	105	115	125	135	150	170	195	225	250	280	340	380											
450	B	20	700	685	660	645	635	620	605	585	570	545	530	515	490	470	440	410											
450	A	25	92	95	100	105	110	115	120	130	140	150	165	175	190	210	230	260	280	325	375	425							
450	B	25	805	800	790	775	760	745	730	715	700	690	670	650	625	605	580	560	540	520	500	480							
450	A	30	100	102	105	108	111	114	117	120	130	140	150	160	170	180	190	220	240	260	280	310	350	380	425	475			
450	B	30	860	856	850	842	834	826	818	810	790	760	750	740	730	720	700	680	660	640	620	600	580	540	520	500			

A= caudal de inyector
B= caudal de bomba

Caudal (kg/h)

PROSPECTO INYECTORES BERGONZO

Presión bomba (bar)

GPH	Atm	3	4	5	6	7	8	9	10	11	12	13	14	15	16	17	18	19	20	21	22	23	24	25	26	27	28	29	30			
475	A	82	88	95	100	110	120	130	145	160	170	195	225	260	300	360																
475	B	800	780	760	740	720	700	680	655	625	600	580	560	520	480	440																
475	A	98	102	108	112	116	120	130	140	150	160	170	180	195	225	250	275	300	350	400	475											
475	B	910	905	900	880	860	840	820	800	780	750	730	710	690	670	650	620	590	560	530	500											
475	A	30	104	107	110	113	117	120	125	135	145	155	163	170	180	190	200	225	250	275	300	325	360	390	440	480						
475	B	1000	990	975	965	945	930	915	900	890	880	860	840	820	800	780	760	730	700	680	660	640	620	590	460							
500	A	20	94	102	106	113	120	130	150	170	190	210	230	250	280	325	380															
500	B	800	780	760	740	720	710	680	660	640	610	580	560	520	500	475																
500	A	25	100	104	108	116	120	130	140	150	160	170	190	210	230	250	270	325	350	400	475											
500	B	900	895	880	865	850	845	830	815	800	780	750	720	700	670	650	620	600	580	550												
500	A	30	110	113	117	120	125	130	135	140	150	160	170	180	190	220	250	280	325	350	380	425	480	520								
500	B	1000	990	980	970	960	950	940	925	910	900	880	860	840	820	800	775	750	725	700	675	650	620	600	575							

Caudal (kg/h)

A= caudal de inyector

B= caudal de bomba

ANOMALIAS DE FUNCIONAMIENTO

CONTROL ANUAL:

El control periódico del quemador (cabeza de combustión, electrodos etc.) tiene que ser efectuado por técnicos autorizados una o dos veces cada año, según la utilización del quemador. Antes de proceder con las operaciones de mantenimiento, es aconsejable comprobar el estado general del quemador actuando de la manera siguiente:

- Desconectar la clavija del quemador de la red.
- Cerrar la válvula de cierre del gas.
- Sacar la tapa del quemador y limpiar ventilador y conducto de aspiración del aire.
- Limpiar la cabeza de combustión y comprobar la posición de los electrodos.
- Remontar el todo.
- Comprobar la estanqueidad de las uniones del gas.
- Comprobar la chimenea.
- Arrancar el quemador y comprobar los parámetros de combustión ($\text{CO}_2 = 9,7\%$ (G 20); $11,7\%$ (G 30); $11,7\%$ (G 31); CO inferior a 75 ppm).

Antes de cada intervención comprobar:

- Que hay corriente en la instalación y que el quemador sea conectado.
- Que la presión del gas sea la correcta y la válvula de cierre esté abierta.
- Que los equipos de control estén debidamente conectados.

Cuando todas estas condiciones se cumplen, arrancar el quemador presionando el botón de bloqueo y comprobar la secuencia de encendido.

El quemador no arranca :

- comprobar el interruptor de arranque, los termostatos, el motor, la presión del gas.
- Interruptor general en posición "0". - Fusibles quemados. - Equipo de control averiado.

El quemador efectúa el prebarrido pero se pone en seguridad al final del ciclo :

- comprobar la presión del aire el ventilador y el presostato del aire.
- Equipo de control averiado.
- Transformador averiado - comprobar el cable de encendido.
- Electrodo sucios, averiados en posición errónea.
- Inyectores obstruidos. - Filtros obstruidos. - Presión del fuel pesado demasiado baja.
- Caudal del aire de combustión demasiado alta en relación al caudal del inyector.

El quemador efectúa el prebarrido pero no se enciende :

- comprobar el montaje y la posición de los electrodos. - comprobar el cable de encendido.
- comprobar el transformador de encendido. - comprobar el equipo de control llama.

El quemador se enciende pero se pone en seguridad al cumplir del tiempo de seguridad :

- comprobar que fase y neutro sean conectados correctamente
- comprobar las electroválvulas del gas y fuel pesado.
- comprobar la fotocelula.
- comprobar el equipo de control llama.
- Inyectores obstruidos.
- La fotocelula no percibe la llama.
- Filtros obstruidos.
- Presión del fuel pesado demasiado baja.
- Caudal del aire de combustión demasiado alta en relación al caudal del inyector.

El quemador se enciende normalmente pero se pone en seguridad después unos minutos de funcionamiento:

- comprobar el regulador de presión y el filtro del gas.
- comprobar la presión del gas y fuel pesado.
- comprobar el valor de detección (mín. 70 μA).

El quemador no entra en la 2a llama (Llama alta):

- Interruptor manual de 1a y 2a llama en el cuadro de mando en posición errónea.
- Equipo de control averiado.
- Bobina de la electroválvula averiado.
- Presión del fuel pesado demasiado baja.
- Filtros obstruidos.
- Inyectores obstruidos o desgastado.
- Servomotor del aire non regulado o averiado.

индекс

1 - ТЕХНИЧЕСКИЕ ХАРАКТЕРИСТИКИ

RU

- ТЕХНИЧЕСКИЕ ХАРАКТЕРИСТИКИp.71
- ГАБАРИТНЫЕ РАЗМЕРЫp.71

2 - МОНТАЖ

- ЭЛЕКТРИЧЕСКИЕ СОЕДИНЕНИЯp.72
- ПОДКЛЮЧЕНИЕ К ГАЗОПРОВОДУp.72

3 - Стартер и регулировки газа

- ЗАПУСК ГОРЕЛКИp.72
- РЕГУЛИРОВАНИЕ ПРОЦЕССА СГОРАНИЯp.72
- РАБОЧИЙ ЦИКЛ ЭЛЕКТРОННОГО ОБОРУДОВАНИЯp.73
- ВОЗДУШНЫЙ СЕРВОПРИВОДp.73,74
- РЕГУЛИРОВАНИЕ ПОЛОЖЕНИЯ ГОЛОВКИp.75
- ТОК ИОНИЗАЦИИp.75
- ДЕМОНТАЖ ОГНЕВОЙ ГОЛОВКИp.76

4 - Стартер и регулировки Мазут

- СИСТЕМА ПОДАЧИ МАЗУТАp.76
- ПРОВЕРКИp.76
- ПУСК ГОРЕЛКИp.77
- РЕГУЛИРОВКИp.77
- ПРЕДВАРИТЕЛЬНАЯ ПРОДУВКАp.78,79
- ПОЛОЖЕНИЕ ЭЛЕКТРОДОВp.80
- РАЗМЕРЫ ФОРСУНОК ДЛЯ МАЗУТАp.81,82,83,84,85

5 - ПОЛЬЗА И ОБСЛУЖИВАНИЕ

- НЕИСПРАВНОСТИ И СПОСОБЫ ИХ УСТРАНЕНИЯp.86

ТЕХНИЧЕСКИЕ ХАРАКТЕРИСТИКИ

МОДЕЛИ	Multiflam 700.1	Multiflam 800.1	Multiflam 1000.1	Multiflam 1200.1
Макс. теплопроизводительность кВт	7.500	8.500	10.500	13.000
ккал/час	6.465.000	7.327.500	9.052.000	11.207.000
Мин. теплопроизводительность кВт	1.500	2.000	2.500	2.700
ккал/час	1.290.000	1.724.000	2.155.000	2.327.600
Давление природного газа мбар	60÷700	85÷700	115÷700	160÷700
Давление сжиж газа мбар	125÷700	185÷700	110÷700	160÷700
Напряжение электропитания 50 Гц В	230/400	230/400	230/400	230/400
Вид топлива : Природный газ(нижн. теплота сгорания 8.570 ккал/нм3), сжиж газа (нижн. теплота сгорания 22.260 ккал/нм3) Мазут (нижн. теплота сгорания 9.800 ккал/кг макс. Вязкость 50°E при 50°С)				

RU

ГАБАРИТНЫЕ РАЗМЕРЫ

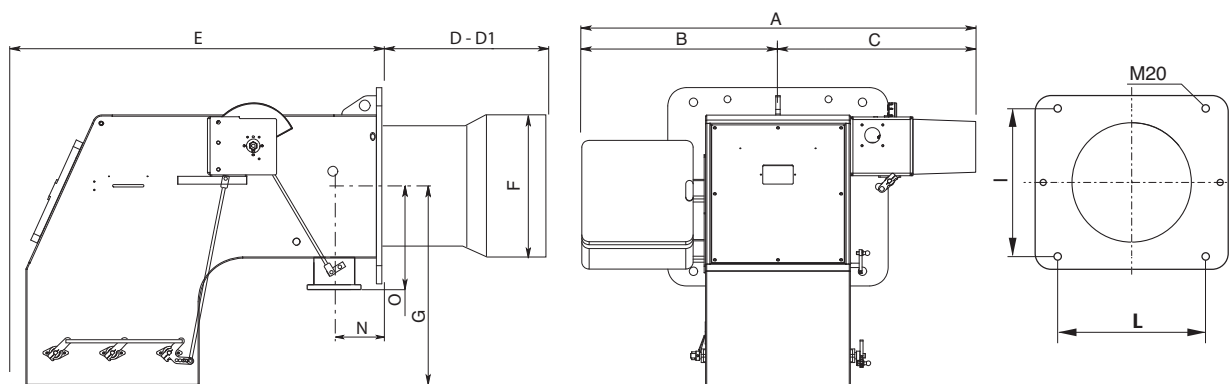

D = короткая головка D1 = длинная головка Размеры в мм

модель	A	B	C	D	D1	E	F	G	I	L	M	N	O
Multiflam 700.1 TS	1170	540	630	470	-	1030	420	550	460	460	M20	195	232
Multiflam 800.1 TS	1170	540	630	470	-	1030	420	550	460	460	M20	195	232
Multiflam 1000.1 TS	1170	540	630	470	-	1030	420	550	460	460	M20	195	232
Multiflam 1200.1 TS	1170	540	630	470	-	1030	450	550	460	460	M20	195	232

ФЛАНЕЦ ВОЗДУХА

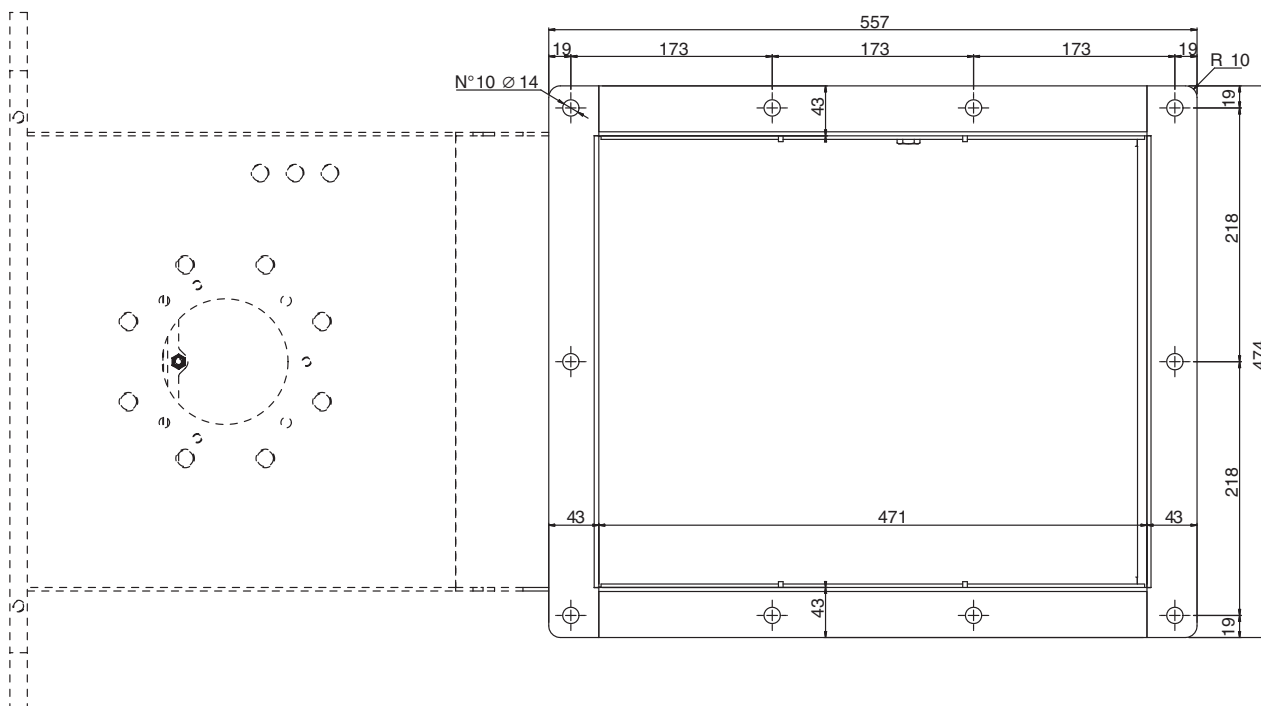

ЭЛЕКТРИЧЕСКИЕ СОЕДИНЕНИЯ

Все двигатели горелок прошли заводские испытания при трехфазном напряжении 400 В 50 Гц, а цепи управления - при однофазном напряжении 230 В 50 Гц + ноль. При необходимости обеспечить электропитание горелки от сети 230 Вольт 50 Гц без нуля, необходимо выполнить подключения, руководствуясь соответствующей электрической схемой. Рабочий диапазон теплового реле должен находиться в пределах потребляемой мощности двигателя.

RU

ПОДКЛЮЧЕНИЕ К ГАЗОПРОВОДУ

После подключения горелки к газопроводу проверить его герметичность. Проверить состояние дымохода (герметичность и отсутствие в нем препятствий и т.п.). Открыть газовый вентиль и осторожно продуть газопровод в направлении гнезда отбора давления; проверить давление с помощью манометра. Подать напряжение и установить термостаты на требуемое значение температуры. После включения термостата в цепь специальное устройство проверяет герметичность клапанов. По завершении контроля горелка получает разрешение на выполнение пускового цикла.

ЗАПУСК И РЕГУЛИРОВАНИЕ ГОРЕЛКИ

Прежде чем зажечь горелку, следует убедиться, что ее монтаж был выполнен правильно. Проверить соответствие схемам электросоединений и состояние трубопроводов системы отопления. До подачи электроэнергии убедиться, что напряжение соответствует параметрам, указанным на табличке технических характеристик. Электрическая схема и пусковой цикл описаны отдельно. Для подключения к горелке панели управления смотрите прилагаемую схему. Особое внимание следует уделить положению нуля и фазы: ни в коем случае не менять их местами! Проверить заземление системы отопления. Для трехфазных двигателей обязательно проверить направление вращения (указано стрелкой). Продуть газопровод для удаления из него посторонних веществ и сдуть из него воздух. Удостовериться, что давление газа находится в пределах, указанных на табличке. Это делается с помощью поверочного манометра, который устанавливается в специальное гнездо отбора давления на горелке. Затем запускается двигатель, и начинается предварительная продувка горелки. Примерно за 30 сек. сервопривод полностью открывает воздушную заслонку. Когда заслонка оказывается в полностью открытом положении, по импульсу, поступающему на аппаратуру управления, начинается цикл предварительной продувки продолжительностью около 66 сек. По завершении продувки сервопривод перемещает заслонку в положение первой ступени, после чего становится возможен розжиг горелки на минимальной мощности. Одновременно с этим подается напряжение на трансформатор розжига, и спустя 3 сек. (предварительный розжиг) напряжение подается на пилотный клапан. Спустя 2 сек. после открывания пилотного клапана трансформатор исключается из электрической цепи. Если розжиг не происходит, не более чем через 2 сек. происходит аварийная остановка горелки. Дроссельный клапан регулирует расход газа в огневой головке. Горелка работает на минимальной мощности (около 30% от максимальной). Модуляционное устройство управляет сервоприводом: в зависимости от потребности системы отопления сервопривод переходит в положение максимального раскрытия либо останавливается в среднем положении. За счет изменения положения сервопривода гарантируется пропорциональность расхода газа и воздуха таким образом, что при любой мощности (30% - 100%) обеспечивается оптимальное качество сгорания.

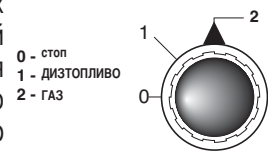

При выключении горелки сервопривод возвращается в положение "закрыто".

ВАЖНЫЕ РЕКОМЕНДАЦИИ:

После тарирования специалистом уставки всех регулируемых устройств должны быть зафиксированы. После каждой регулировки выполнять анализ дымовых газов в дымоходе.

РЕГУЛИРОВАНИЕ ПРОЦЕССА СГОРАНИЯ

ВНИМАНИЕ: для правильного регулирования процесса сгорания и теплопроизводительности необходимо с помощью соответствующих приборов произвести анализ дымовых газов. Регулирование сгорания и теплопроизводительности выполняется одновременно с анализом продуктов сгорания, при этом необходимо убедиться в правильности выполненных замеров. В любом случае показатели должны соответствовать действующим нормам безопасности. См. приведенные таблицу и график. ЭТИ РАБОТЫ ДОЛЖНЫ ВЫПОЛНЯТЬСЯ КВАЛИФИЦИРОВАННЫМ ПЕРСОНАЛОМ, ИМЕЮЩИМ СООТВЕТСТВУЮЩЕЕ РАЗРЕШЕНИЕ КОМПАНИИ "ЭКОФЛАМ".

ВНИМАНИЕ: ВСЕ ПРЕДОХРАНИТЕЛЬНЫЕ УСТРОЙСТВА (РЕЛЕ ДАВЛЕНИЯ ВОЗДУХА, РЕЛЕ МИНИМАЛЬНОГО ДАВЛЕНИЯ ГАЗА, ГАЗОВЫЕ ЭЛЕКТРОКЛАПАНЫ И СТАБИЛИЗАТОР ДАВЛЕНИЯ) ТАРИРУЮТСЯ СПЕЦИАЛИСТАМИ, ИМЕЮЩИМИ СООТВЕТСТВУЮЩЕЕ РАЗРЕШЕНИЕ КОМПАНИИ "ЭКОФЛАМ", И ПОСЛЕ ЗАПУСКА ГОРЕЛКИ ДОЛЖНЫ БЫТЬ ЗАПЛОМБИРОВАНЫ.

РАБОЧИЙ ЦИКЛ ЭЛЕКТРОННОЙ АППАРАТУРЫ LANDIS & STAEFFA, МОДЕЛЬ LFL1.622-LFL1.333

Ref.	Наименование	Duration
t1	время ожидания подтверждения давления воздуха	8"
t2	время продувки	66"(36")
t3	время аварийной остановки	2"
t4	время предварительного розжига	4"
t5	время разрешения вкл. рабочего топливн. клапана на миним. мощности	10"
t6	время разрешения вкл. рабочего топливн. клапана на макс. мощности	10"

Электронное оборудование контроля пламени запускает вентилятор горелки для выполнения предварительно продувки камеры сгорания, при этом реле давления воздуха контролирует создаваемое вентилятором давление. По окончании предварительной продувки вступает в работу трансформатор розжига, между электродами образуется искра, и одновременно с этим открываются газовые клапаны (предохранительный клапан VS и рабочий клапан 1-й степени VL). В случае неудачного розжига или случайного затухания безопасность обеспечивается ионизационным датчиком, который блокирует оборудование в течение времени аварийной остановки. В случае отсутствия газа или значительного падения его давления реле минимального давления газа прерывает работу горелки.

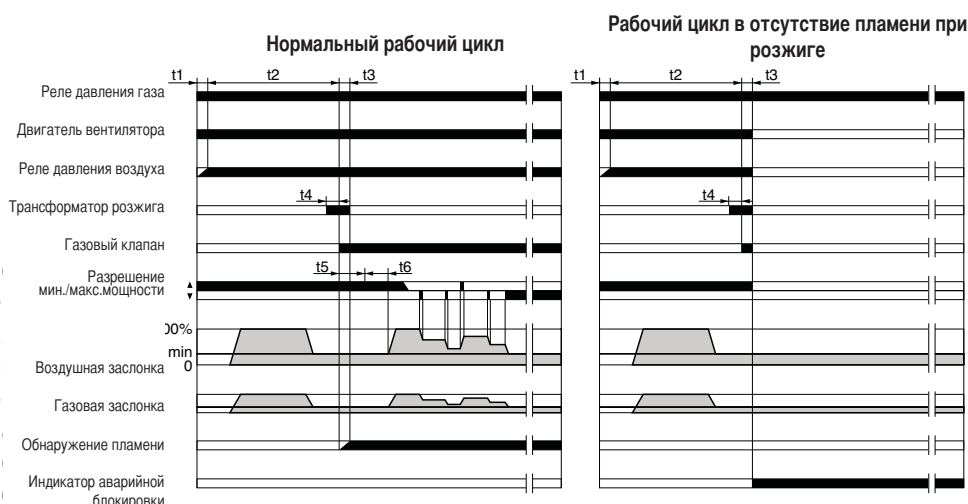

RU

ВОЗДУШНЫЙ СЕРВОПРИВОД LANDIS & STAEFFA SQM 50.481A2

Для доступа к регулировочным кулачкам снять крышку. Регулировка кулачков производится с помощью специального ключа в комплекте следующим образом:



- I - Кулачок для регулировки расхода воздуха на 2-й ступени (мазут / газ)
- II - Концевой выключатель положения воздушной заслонки при гашении горелки
- III - Кулачок для регулировки расхода воздуха при розжиге (газ).
- IV - Кулачок для регулировки расхода воздуха при розжиге (мазут).
- V - Кулачок для регулировки расхода воздуха на 1-й ступени (газ).
- VI - Кулачок для регулировки расхода воздуха на 1-й ступени (мазут).
- VII - Кулачок для регулировки расхода воздуха на 2-й ступени (газ).
- VIII - Кулачок не используется.

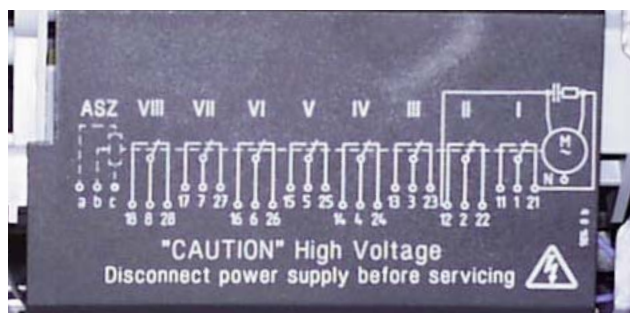

РАСЧЕТ МОЩНОСТИ ГОРЕЛКИ

Замерить по счетчику расход газа в литрах и время замера в секундах. Мощность в кВт рассчитывается по следующей формуле:
$$f = \frac{e}{sec} \times f = kW$$

e = кол-во газа в литрах

sec = время в секундах

- f** метан = 34,02
- бутан = 116
- пропан = 88

РЕГУЛИРОВАНИЕ РАСХОДА ВОЗДУХА И ГАЗА

RU

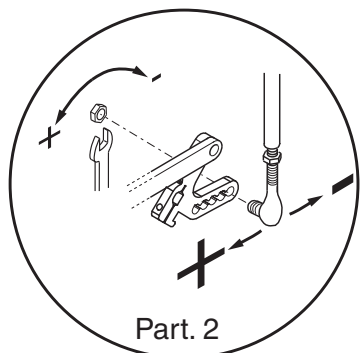

Part. 2

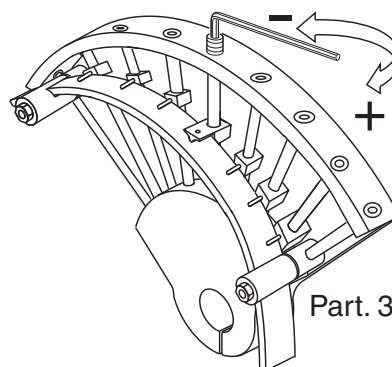

Part. 3

ПЕРЕКЛЮЧАТЕЛЬ



0 = аппаратура управления заблокирована для работы в среднем диапазоне мощности

👁 = работа на максимальной мощности

👁 = работа на минимальной мощности

AUTO = автоматический режим

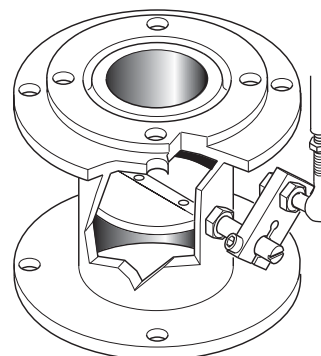

РЕГУЛИРОВКА МИНИМАЛЬНОЙ МОЩНОСТИ ГОРЕЛКИ – ВОЗДУХ И ГАЗ

Установите переключатель на панели управления в положение 2 и выполните следующие действия: Отрегулируйте минимальный расход газа, вращая соответствующим ключом дроссельный клапан, пока не будет достигнут требуемый расход газа, что определяется по результатам анализа процесса сгорания.

РЕГУЛИРОВКА МАКСИМАЛЬНОГО РАСХОДА ГАЗА

Поставьте переключатель на панели управления в положение 1 и выполните следующие действия: Отрегулируйте максимальный расход газа (регулировка электромагнитного клапана показана на рисунке) или отрегулируйте газовым регулятором давление газа.

РЕГУЛИРОВКА МАКСИМАЛЬНОГО РАСХОДА ВОЗДУХА

Регулировка максимального расхода воздуха (см. рисунок, деталь 2). Ослабьте гайку, блокирующую приводной шток воздушной заслонки; правильный расход воздуха устанавливается по результатам анализа продуктов сгорания.

РЕГУЛИРОВКА РАБОТЫ ГОРЕЛКИ НА СРЕДНЕЙ МОЩНОСТИ

Переключателем включить сервопривод (закрывание или открывание) и прервать его ход, переведя переключатель в положение 0; выполнить регулировку по приведенным ниже инструкциям. Повторить эту операцию для всех остальных кулачков. Регулировка расхода газа на средней мощности (см. рисунок, деталь 3): - при помощи шестигранного гаечного ключа изменить изгиб направляющей пластинки кулачков. При вращении по часовой стрелке расход уменьшается, против часовой стрелки – увеличивается.

РЕГУЛИРОВАНИЕ СГОРАНИЯ

ВНИМАНИЕ: Регулирование сгорания и теплопроизводительности по теплу выполняется одновременно с анализом продуктов сгорания, при этом необходимо убедиться в правильности выполненных замеров; в любом случае показатели должны соответствовать действующим нормам безопасности. ЭТИ РАБОТЫ ДОЛЖНЫ ВЫПОЛНЯТЬСЯ КВАЛИФИЦИРОВАННЫМ ПЕРСОНАЛОМ, ИМЕЮЩИМ СООТВЕТСТВУЮЩЕЕ РАЗРЕШЕНИЕ КОМПАНИИ "ЭКОФЛАМ".

РЕГУЛИРОВАНИЕ ПОЛОЖЕНИЯ ГОЛОВКИ ГОРЕЛИ

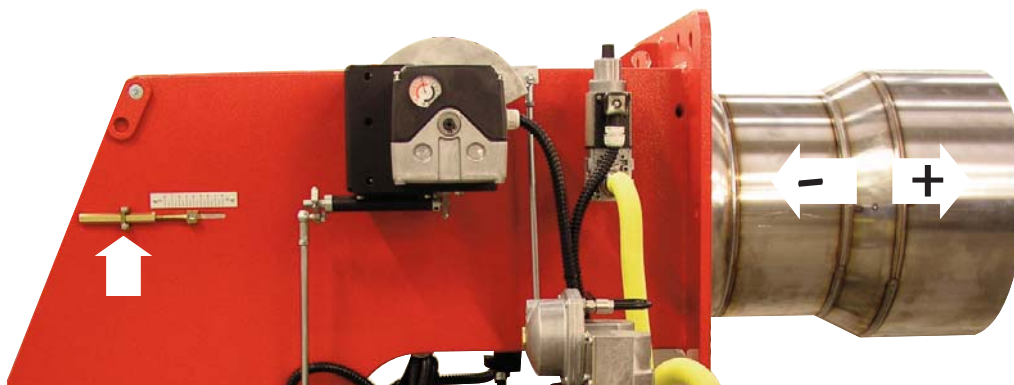

RU

ТАРИРОВАНИЕ РЕЛЕ МИНИМАЛЬНОГО ДАВЛЕНИЯ ГАЗА

Отвинтить винты **I** и **L** и снять крышку **M**. Установить регулятор **N** на значение равное 60% номинального давления газа (например, при номинальном давлении метана 20 мбар регулятор устанавливается на значение 12 мбар; для сжиженного газа с номинальным давлением 30/37 мбар регулятор устанавливается на значение 18 мбар). Установить на место крышку **M** и вернуть винты **I** и **L**.

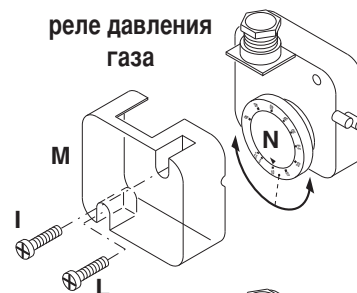

РЕГУЛИРОВАНИЕ РЕЛЕ ДАВЛЕНИЯ ВОЗДУХА

Отвинтить винты **A** и **B** и снять крышку **C** и установить реле давления на минимум, поставив регулятор **D** в положение 1. Запустить горелку на 1-й ступени мощности; убедиться, что процесс сгорания проходит качественно. С помощью картонки постепенно закрывать всасывающий воздуховод вплоть до повышения значения CO2 на 0,5 - 0,8%, либо при наличии манометра, подключенного к гнезду отбора давления **E** - до уменьшения давления на 0,1 мбар (~ 10 мм в.с.). Постепенно увеличивать тарировочное значение реле давления вплоть до аварийного гашения горелки. Освободить всасывающий воздуховод, установить обратно крышку **C** и затем нажатием кнопки перезапуска контрольной аппаратуры вновь запустить горелку.

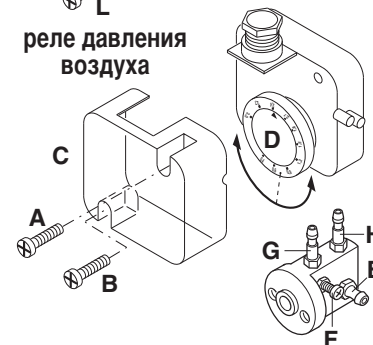

ПРОВЕРКА СИСТЕМЫ ОБНАРУЖЕНИЯ ПЛАМЕНИ

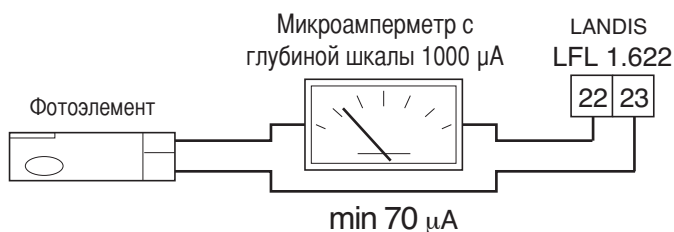

Ток ионизации проверяется с помощью микроамперметра с глубиной шкалы 1000 µA (постоянного тока), который последовательно подключается к фотоэлементу. Как правило, сила тока должна быть не ниже 70 µA.

ДЕМОНТАЖ СТАКАНА

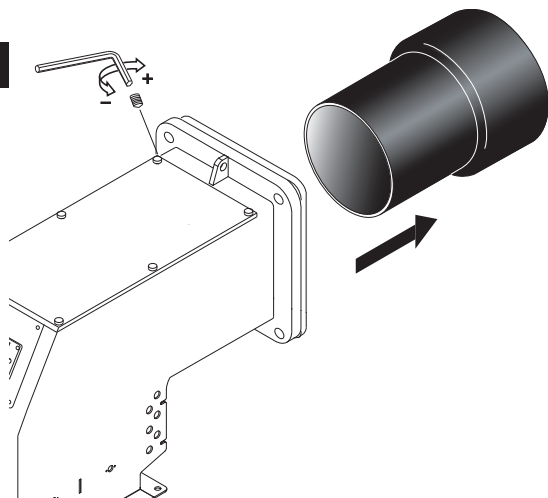

ДЕМОНТАЖ ГОЛОВКИ ГОРЕЛКИ

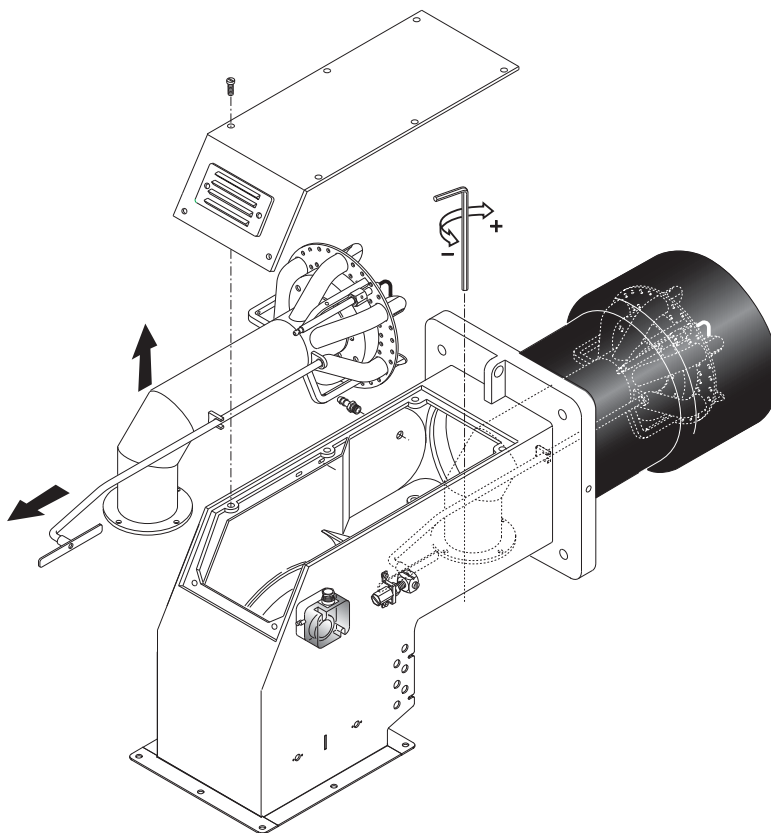

ГОРЕЛКА СОЕДИНЕНИЯ МАСЛА



ПРОВЕРКА ПРАВИЛЬНОСТИ МОНТАЖА:

Прежде чем, приступить к заполнению топливопровода и к последующему пуску оборудования рекомендуется убедиться в том, что:

- Система электроснабжения соответствует потребляемой мощности оборудования
- Предохранители соответствуют нагрузке оборудования
- Термостаты котла подключены правильно
- Напряжение и частота тока не превышают указанных для данной горелки значений
- Тип топлива соответствует указанному производителем горелки
- Сечение топливопровода обеспечивает требуемый расход топлива
- Фильтры, вентили и фитинги смонтированы правильно
- Длина стакана горелки соответствует характеристикам котла, указанным его производителем.
- Производительность форсунок соответствует мощности котла

МОДУЛЯЦИЯ

Когда выключатель горелки находится в положении "пуск", а контакты термостатов замкнуты, напряжение подается на электронагревательные элементы (G) в бачке горелки и насосов и в линию топливоснабжения и огневую головку (O). Когда термостат в бачке горелки определяет заданную температуру (обычно, для обеспечения хорошей циркуляции не менее 90°C), включается насос (при использовании терморегулятора GEFRAN 200 уставка – 1). Если в системе предварительного подогрева предусмотрен жидкостный теплообменник (го рячая, вода, пар, диатермическое масло), термостат может передавать сигнал, включающий или выключающий электроклапан, который регулирует ток жидкости.

Это не является стандартным решением, поскольку ток теплоносителя, как правило, никогда не перекрывается. Насос начинает подавать топливо (поскольку огневая головка уже разогрета соответствующим Тэном (O), в ней нет загустевшего холодного мазута). Топливо поступает из бака в головку и в обратный контур.

Когда термостат головки определяет заданную температуру (обычно 70-30°C) начинается рабочий цикл и регулятор дает разрешение на пуск. Сервопривод автоматически устанавливается на минимум (см. описание регулировки) и регулирует расход воздуха и топлива посредством регулятора давления в обратном контуре. Электромагнит (A) открывает форсунку (Q) при следующих условиях:

- электроды розжига, на которые с трансформатора поступает ток, создают искру. Трансформатор находится под контролем блока управления горелки.

Если фотоэлемент не обнаруживает пламя, горелка выключается (цикл контролируется регулятором). Когда же розжиг прошел успешно и после стабилизации факела система начинает работать в режиме модуляции. Перед пуском необходимо убедиться, что насос и топливопровод заполнены горячим мазутом - работа насоса без топлива может привести к его разрушению. Если происходит блокировка, на регуляторе и на блоке управления горелки загораются предупреждающие индикаторы. Этот сигнал обычно также подается на аппаратуру управления оборудования, с которым используется горелка, и включает зуммер и световую аварийную индикацию. Несколько блокировок (до 4) при первом пуске являются нормальным явлением. Для сброса блокировки и повтора цикла нажать кнопку на регуляторе (такая кнопка имеется также на пульте управления горелки). Если блокировки продолжаются, следует обратиться к сервисному специалисту.

ВНИМАНИЕ: В целях выявления причины блокировки положение регулятора на момент блокировки вносится в память.

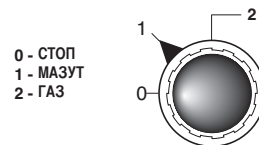

RU

РЕГУЛИРОВКА ДАВЛЕНИЯ ТОПЛИВА В ОБРАТНОМ КОНТУРЕ

На рисунке показана система регулирования топлива в обратном контуре в горелках, где используется форсунка с поступательным регулированием расхода топлива в обратном контуре. Расход топлива может регулироваться путем изменения давления в обратном контуре форсунки. Максимальный расход топлива достигается, когда давление насоса равняется примерно 30 бар, а обратный контур полностью перекрыт. Минимальный расход топлива достигается, когда обратный контур полностью открыт. Давление на выходе насоса определяется с помощью манометра, который устанавливается на насосе. Давление в обратном контуре определяется по манометру, установленному на регуляторе давления горелки (включен в комплект поставки).

Напор топливного насоса 22-30 бар.

Обратное давление топлива при максимальной мощности горелки:

форсунка FLUIDICS : 16 -19 бар.

форсунка BERGONZO : 20 -24 бар.

Обратное давление топлива при максимальной мощности горелки:

форсунка FLUIDICS: 6-9 бар

форсунка BERGONZO: 4 -8 бар



RU

ПРЕДВАРИТЕЛЬНАЯ ПРОДУВКА

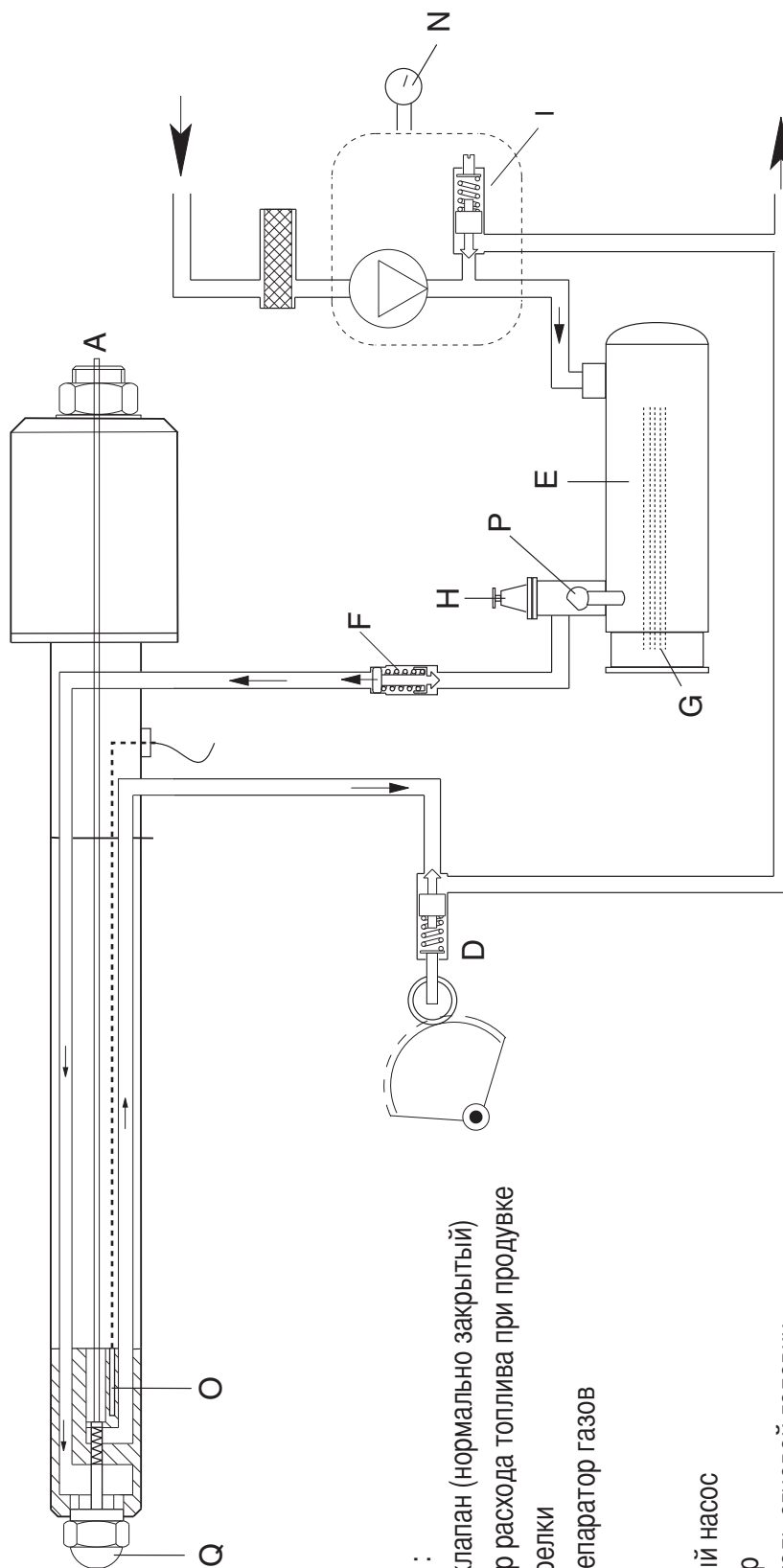

Экспликация :

- A Электродвигатель (нормально закрытый)
- D Регулятор расхода топлива при продувке
- E Бачок горелки
- F Клапан-сепаратор газов
- G ТЭНы
- H Фильтр
- I Топливный насос
- N Манометр
- O Нагреватель огневой головки
- P Датчик температуры топлива
- Q Форсунка

ПРЕДВАРИТЕЛЬНАЯ ПРОДУВКА

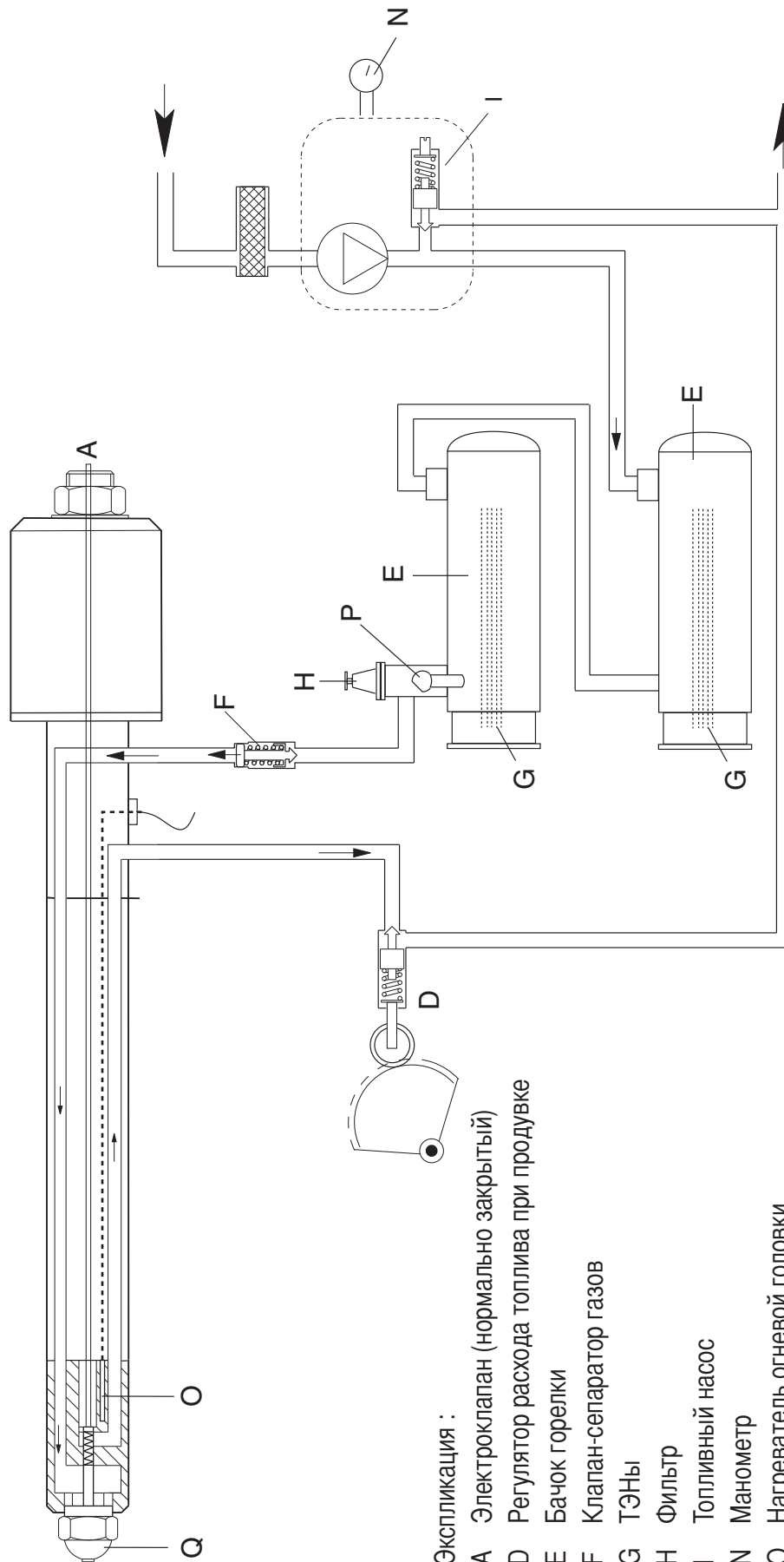

- Экспликация :
- A Электрорасходомер (нормально закрытый)
 - D Регулятор расхода топлива при продувке
 - E Бачок горелки
 - F Клапан-сепаратор газов
 - G ТЭНы
 - H Фильтр
 - I Топливный насос
 - N Манометр
 - O Нагреватель огневой головки
 - P Датчик температуры топлива
 - Q Форсунка

ПОЛОЖЕНИЕ ЭЛЕКТРОДОВ

RU

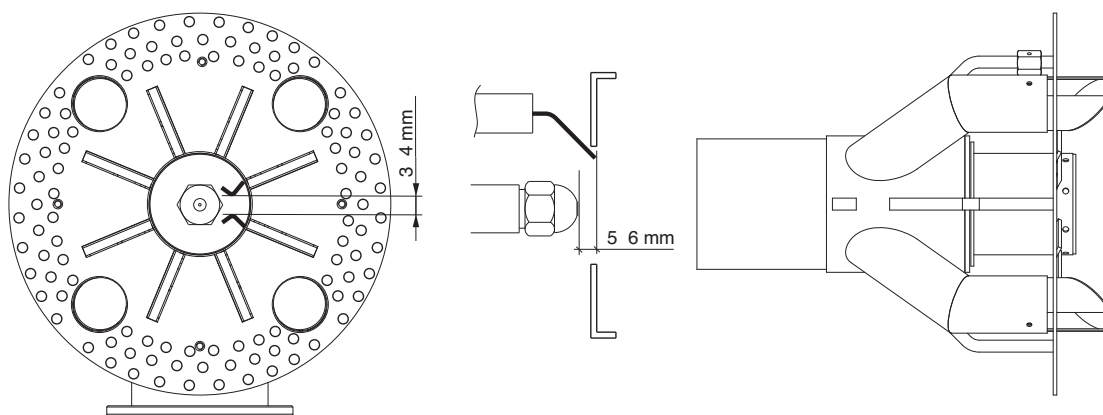

ЧИСТКА И ЗАМЕНА ФОРСУНКИ

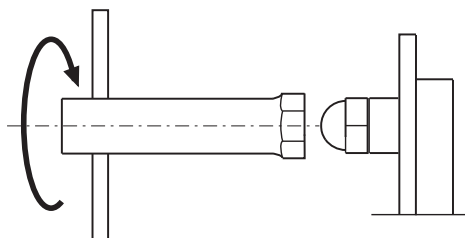

Для демонтажа форсунки пользуйтесь исключительно имеющимся в комплекте ключом. Обратите внимание на то, что бы не повредить электроды. Установите новую форсунку, при этом работу следует выполнять с максимальной осторожностью. Примечание: после замены форсунки, обязательно проверьте положение электродов (см. рис.) Неправильное положение электродов может затруднить розжиг горелки.

Форсунка FLUIDICS

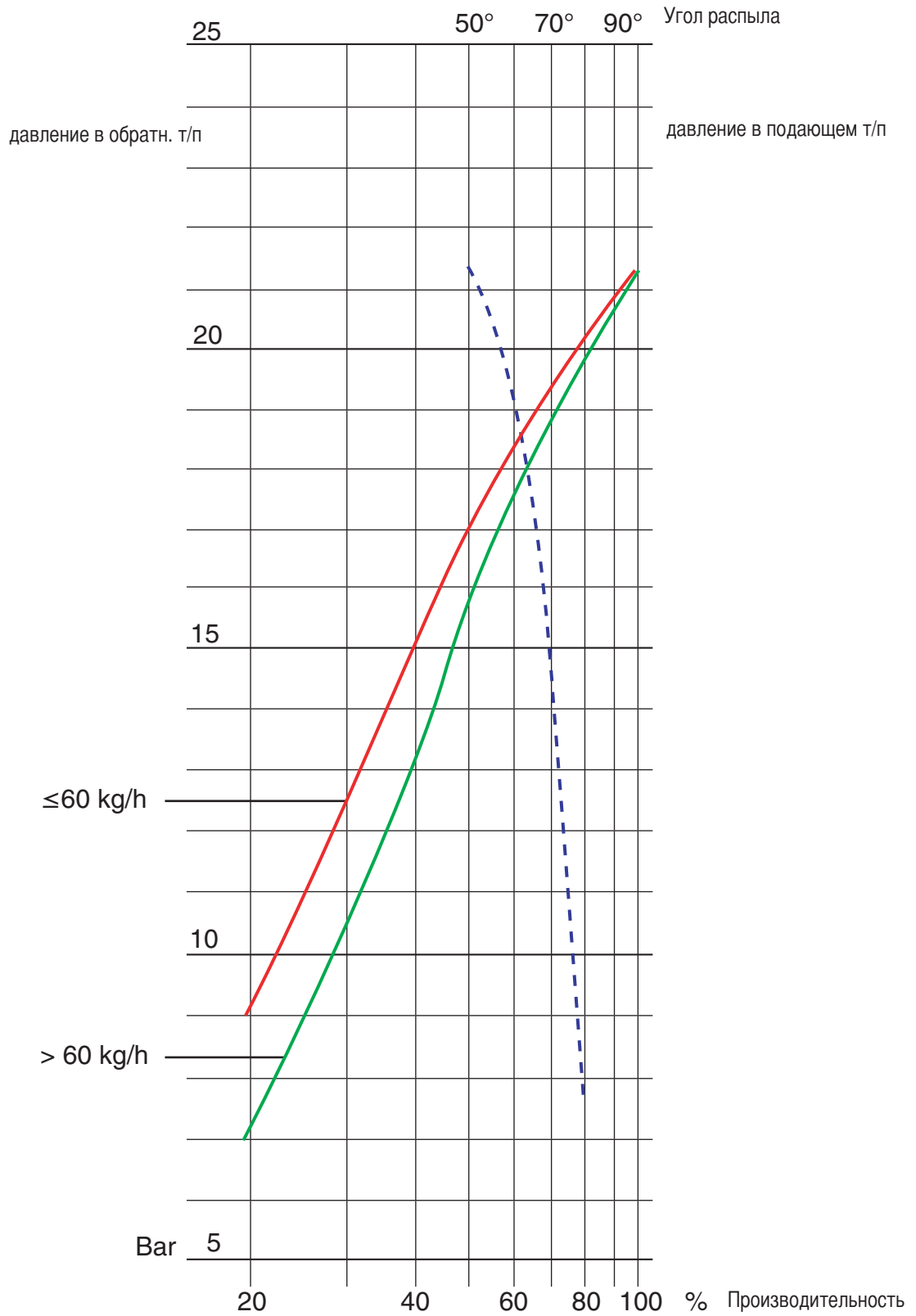

RU

РАЗМЕРЫ ФОРСУНОК BERGONZO

Давление топливного насоса (бар)

ГРН	Atm	3	4	5	6	7	8	9	10	11	12	13	14	15	16	17	18	19	20	21	22	23	24	25	26	27	28	29	30
125	A	20	22	23	25	26	27	29	32	34	37	40	44	50	57	65	77	95											
125	B	20	285	280	275	274	272	271	245	235	220	205	190	175	160	145	130	115											
125	A	25	24	25	26	27	28	29	30	31	32	34	35	37	40	43	45	52	60	68	80	95	115						
125	B	25	330	328	325	320	315	307	300	285	280	275	260	250	235	220	190	180	170	168	150	135							
125	A	30	25	26	26	27	28	28	29	30	31	32	33	35	37	38	42	43	46	50	54	60	65	72	80	90	108	130	
125	B	30	370	365	360	355	350	348	345	340	335	328	320	305	300	290	280	270	260	245	240	225	210	190	180	165	150	130	
150	A	20	30	33	34	35	37	39	43	46	50	55	60	68	75	85	100	120											
150	B	20	325	320	315	308	300	290	285	275	260	250	240	220	190	180	160	140											
150	A	25	32	33	34	35	37	38	42	45	47	50	55	60	65	70	78	83	94	110	120	150							
150	B	25	375	370	365	363	358	355	350	345	330	320	310	300	285	275	260	250	240	220	195	180	150						
150	A	30	35	36	36	37	37	39	41	42	45	46	48	50	54	58	62	65	70	75	80	88	95	110	120	140	180		
150	B	30	420	420	415	410	405	400	395	390	380	375	365	350	345	340	330	320	300	290	280	270	250	240	220	200	180		
175	A	20	35	37	39	42	44	46	48	55	58	62	68	75	84	95	118	155											
175	B	20	350	350	349	348	330	325	315	300	290	280	265	248	225	195	175	155											
175	A	25	35	36	37	41	42	44	45	47	50	52	58	62	65	70	78	88	95	110	120	140	170						
175	B	25	395	390	385	382	380	378	370	360	350	348	330	325	315	300	280	275	260	240	225	200	170						
175	A	30	42	43	44	45	46	47	48	50	52	55	58	60	62	65	70	72	78	85	90	100	110	118	135	158	190		
175	B	30	440	440	435	430	425	420	415	410	408	400	390	380	370	360	350	330	320	300	285	275	260	250	235	220	200	190	
200	A	20	38	40	42	44	47	50	55	60	65	70	80	90	100	120	140	170											
200	B	20	400	398	388	380	370	360	350	340	330	320	300	280	275	250	230	210											
200	A	25	42	43	43	44	45	47	50	52	55	60	65	70	78	85	95	105	115	130	150	170	220						
200	B	25	450	448	448	445	440	430	425	412	405	400	390	380	375	360	345	325	315	290	280	260	220						
200	A	30	48	49	50	51	52	53	55	56	58	60	62	64	68	70	75	80	85	92	100	110	120	130	150	175	200		
200	B	30	500	500	495	490	485	480	475	470	460	450	440	430	420	410	395	385	375	350	340	325	315	300	290	275	260		
225	A	20	42	43	45	47	48	52	56	60	65	70	80	90	100	115	140	180											
225	B	20	420	410	405	400	395	380	375	365	350	345	335	320	300	280	265	250											
225	A	25	45	46	47	48	50	52	55	58	60	63	68	73	80	90	98	108	120	140	160	180	225						
225	B	25	475	468	460	455	450	445	445	437	425	410	400	380	375	360	350	340	315	300	280	260	240						
225	A	30	50	50	51	52	52	53	54	55	57	60	62	66	68	75	80	88	94	100	110	120	130	140	155	175	200	240	
225	B	30	510	510	505	505	503	500	495	490	480	460	440	430	420	410	400	390	380	370	360	350	340	325	310	300	285	275	
250	A	20	42	44	46	47	50	55	60	65	70	80	90	100	115	140	160	220											
250	B	20	425	415	408	403	400	380	375	365	350	338	325	300	280	265	250	240											
250	A	25	46	47	49	50	52	55	58	60	63	66	72	78	85	92	100	110	130	140	165	200							
250	B	25	480	475	475	470	465	450	445	440	425	410	400	380	375	355	340	330	310	300	280	275							
250	A	30	52	52	52	53	54	55	58	60	62	65	68	72	78	82	90	95	105	105	125	135	150	165	180	220	260		
250	B	30	520	515	515	510	510	505	500	490	480	475	460	450	440	430	420	400	380	370	360	350	340	325	310	280			
275	A	20	52	53	55	58	60	63	68	75	80	90	100	115	125	150	170	225											
275	B	20	540	530	520	510	500	490	475	450	440	420	400	375	350	325	300	275											
275	A	25	55	56	57	58	60	64	68	70	75	80	85	95	100	115	125	135	150	170	190	225	265						
275	B	25	600	600	595	590	580	570	560	550	540	525	510	500	480	460	440	425	400	375	350	325	300						
275	A	30	60	61	62	63	64	65	66	67	70	74	78	82	88	95	100	110	118	125	135	150	165	180	200	240	275		
275	B	30	680	675	668	662	658	650	640	630	620	610	600	590	580	565	555	545	525	500	480	460	440	425	400	375	350		

Расход топлива (кг/ч)

A= Расход Форсунка B= Расход насоса

РАЗМЕРЫ ФОРСУНОК BERGONZO

Давление топливного насоса (бар)

GRH	Atm	3	4	5	6	7	8	9	10	11	12	13	14	15	16	17	18	19	20	21	22	23	24	25	26	27	28	29	30
300	A	20	55	58	60	64	65	70	76	85	92	105	118	135	145	175	200	270											
300	B	20	550	535	525	515	500	485	470	450	430	410	380	375	360	330	310	280											
300	A	25	24	25	26	27	28	29	30	31	32	34	35	37	40	43	45	52	60	68	80	95	115						
300	B	25	330	328	325	320	315	307	300	285	280	275	260	250	235	220	190	180	170	168	150	135							
300	A	30	25	26	26	27	28	28	29	30	31	32	33	35	37	38	42	43	46	50	54	60	65	72	80	90	108	130	
300	B	30	370	365	360	355	350	348	345	340	335	328	320	305	300	290	280	270	260	245	240	225	210	190	180	165	150	130	
325	A	20	58	62	65	68	72	78	88	95	110	118	135	150	170	200	240	290											
325	B	20	570	560	550	530	510	500	485	475	450	440	425	400	370	350	330	300											
325	A	25	65	67	69	72	74	75	80	85	90	98	105	115	125	140	160	170	190	225	270	320							
325	B	25	650	643	638	630	628	620	610	600	590	580	565	540	520	500	475	450	425	400	375	350							
325	A	30	68	69	70	71	73	75	78	82	88	92	98	105	110	120	130	140	150	165	180	200	225	250	280	320	360		
325	B	30	720	715	710	705	702	700	690	680	670	655	620	610	600	580	570	550	520	500	480	460	440	420	400	380			
350	A	20	64	68	70	75	80	90	98	105	118	130	145	160	180	210	250	310											
350	B	20	620	600	590	580	570	550	530	500	480	460	440	420	400	375	360	340											
350	A	25	68	69	70	75	80	85	90	98	105	112	120	130	145	160	170	190	210	240	270	300	350						
350	B	25	700	700	690	680	670	660	650	630	610	590	580	550	520	500	480	465	450	430	410	380	360						
350	A	30	68	69	70	73	78	82	88	92	98	105	110	120	128	138	145	160	170	190	210	225	250	275	300	350	375		
350	B	30	790	780	770	760	750	740	720	710	700	690	680	665	650	625	610	590	570	550	520	505	490	475	440	425	400		
375	A	20	72	76	82	88	94	105	115	125	140	155	170	195	225	250	300												
375	B	20	630	615	600	590	580	565	550	520	490	475	450	425	400	375	360												
375	A	25	78	80	85	90	95	100	105	110	120	130	140	155	170	190	200	230	250	280	325	375							
375	B	25	700	690	680	670	660	650	640	625	615	600	580	565	550	520	500	480	460	440	420	400							
375	A	30	90	92	93	95	98	100	105	110	115	120	130	140	150	160	170	180	200	220	240	260	280	320	350	400			
375	B	30	800	790	786	778	770	760	750	730	710	700	690	670	650	630	610	600	590	570	550	530	510	490	470	440			
400	A	20	85	90	98	105	115	125	135	150	165	185	210	240	270	320													
400	B	20	610	605	595	585	575	565	550	520	500	480	460	440	420	400													
400	A	25	85	90	98	104	110	118	125	135	145	155	170	190	200	225	250	280	310	360	400								
400	B	25	710	705	700	695	690	680	670	650	630	610	590	580	560	540	520	500	480	450	425								
400	A	30	100	102	106	110	114	117	120	130	138	148	158	170	180	195	210	230	250	275	300	340	360	400	440				
400	B	30	800	790	786	778	770	760	750	730	710	700	690	670	650	630	610	600	590	570	550	530	510	490	470	440			
425	A	20	78	80	85	90	95	100	110	120	135	150	170	190	220	250	300	350											
425	B	20	700	690	680	670	650	630	615	600	590	570	530	510	490	450	410	380											
425	A	25	85	88	90	93	95	100	105	110	120	130	140	150	165	180	195	225	250	280	325	380							
425	B	25	750	745	740	730	720	710	700	685	675	665	650	630	610	600	580	560	540	515	490	430							
425	A	30	91	92	94	96	98	99	100	104	110	118	128	138	145	158	168	180	195	210	235	260	280	320	350	400	450		
425	B	30	820	816	812	808	804	800	790	780	770	760	750	740	730	720	710	695	680	650	625	600	590	570	540	515	490		
450	A	20	86	90	94	98	105	115	125	135	150	170	195	225	250	280	340	380											
450	B	20	700	685	660	645	635	620	605	585	570	545	530	515	490	470	440	410											
450	A	25	92	95	100	105	110	115	120	130	140	150	165	175	190	210	230	260	280	325	375	425							
450	B	25	805	800	790	775	760	745	730	715	700	690	670	650	625	605	580	540	520	500	480								
450	A	30	100	102	105	108	111	114	117	120	130	140	150	160	170	180	190	220	240	260	280	310	350	380	425	475			
450	B	30	860	856	850	842	834	826	818	810	790	760	750	740	730	720	700	680	660	640	620	600	580	540	520	500			

Расход топлива (кг/ч)

A= Расход Форсунок B= Расход насоса

РАЗМЕРЫ ФОРСУНОК BERGONZO

Давление топливного насоса (бар)

GRH	Atm	3	4	5	6	7	8	9	10	11	12	13	14	15	16	17	18	19	20	21	22	23	24	25	26	27	28	29	30			
475	A	20	82	88	95	100	110	120	130	145	160	170	195	225	260	300	360															
475	B	20	800	780	760	740	720	700	680	655	625	600	580	560	520	480	440															
475	A	25	98	102	108	112	116	120	130	140	150	160	170	180	195	225	250	275	300	350	400	475										
475	B	25	910	905	900	880	860	840	820	800	780	750	730	710	690	670	650	620	590	560	530	500										
475	A	30	104	107	110	113	117	120	125	135	145	155	163	170	180	190	200	225	250	275	300	325	360	390	440	480						
475	B	30	1000	990	975	965	945	930	915	900	890	880	860	840	820	800	780	760	730	700	680	660	640	620	590	460						
500	A	20	94	102	106	113	120	130	150	170	190	210	230	250	280	325	380															
500	B	20	800	780	760	740	720	710	680	660	640	610	580	560	520	500	475															
500	A	25	100	104	108	116	120	130	140	150	160	170	190	210	230	250	270	325	350	400	475											
500	B	25	900	895	880	865	850	845	830	815	800	780	750	720	700	670	650	620	600	580	550											
500	A	30	110	113	117	120	125	130	135	140	150	160	170	180	190	220	250	280	300	325	350	380	425	480	520							
500	B	30	1000	990	980	970	960	950	940	925	910	900	880	860	840	820	800	775	750	725	700	775	750	725	600	575						

Расход топлива (кг/ч)

A= Расход Форсунка B= Расход насоса

ТЕКУЩЕЕ ТЕХНИЧЕСКОЕ ОБСЛУЖИВАНИЕ

Периодическое обслуживание горелки (головки, электродов и т.д.) должно выполняться квалифицированным персоналом. В зависимости от условий эксплуатации это делается 1 или 2 раза в год.

Прежде чем приступить к проверке и последующему обслуживанию горелки рекомендуется произвести её общий осмотр. Для этого:

- Отключить энергоснабжение горелки (вытащить штекер).
- Закрывать отсечной газовый кран.
- Снять крышку горелки, прочистить вентилятор и всасывающий воздухопровод.
- Прочистить головку горелки и проверить положение электродов.
- Установить обратно все детали.
- Проверить герметичность газовых соединений.
- Проверить дымоход.
- Запустить горелку.
- Произвести анализ продуктов сгорания: CO₂ = 9,5 - 9,8, CO = не более 75 ppm).

ПЕРЕД КАЖДОЙ ИЗ ОПИСАННЫХ ДАЛЕЕ ОПЕРАЦИЙ НЕОБХОДИМО ПРОВЕРИТЬ, ЧТО:

- напряжение подается на установку, а горелка подключена;
- в сети имеется требуемое давления газа, и отсечной газовый кран находится в открытом положении;
- предохранительные устройства и приборы управления подключены правильно;

Если все вышеупомянутые условия соблюдены, нажатием кнопки перезапуска запустить горелку. Проверить рабочий цикл горелки.

ЗАПУСК ГОРЕЛКИ НЕ ПРОИСХОДИТ:

- Проверить выключатель, термостаты, двигатель и давление газа
- Главный выключатель находится в положении "0"
- Вышли из строя предохранители
- Вышла из строя аппаратура управления

ПОСЛЕ ПРЕДВАРИТЕЛЬНОЙ ПРОДУВКИ ПРОИСХОДИТ БЛОКИРОВКА ГОРЕЛКИ:

- Проверить давление газа и вентилятор
- Проверить реле давления воздуха
- Вышла из строя аппаратура управления
- Вышел из строя трансформатор
- Проверить провод зажигания
- Электроды загрязнились, вышли из строя или находятся в неправильном положении
- Засорены или изношены форсунки
- Засорились фильтры
- Недостаточное давление дизтоплива
- Слишком большой расход воздуха горения для форсунки данной производительности

ПОСЛЕ ПРЕДВАРИТЕЛЬНОЙ ПРОДУВКИ РОЗЖИГ ГОРЕЛКИ НЕ ПРОИСХОДИТ:

- Проверить правильность установки электродов
- Проверить провод зажигания
- Проверить трансформатор розжига
- Проверить предохранительные устройства

ПОСЛЕ РОЗЖИГА ПО ИСТЕЧЕНИИ ВРЕМЕНИ АВАРИЙНОЙ ОСТАНОВКИ ПРОИСХОДИТ БЛОКИРОВКА ГОРЕЛКИ :

- Проверить правильность подключения фазы и нуля
- Проверить газовые электроклапаны
- Проверить положение и правильность подключения электрода обнаружения пламени
- Проверить предохранительные устройства
- Засорены или изношены форсунки
- Фотоэлемент не "видит" пламя
- Засорились фильтры
- Недостаточное давление дизтоплива
- Слишком большой расход воздуха горения для форсунки данной производительности

БЛОКИРОВКА ГОРЕЛКИ ПРОИСХОДИТ ПОСЛЕ ЕЁ НЕПРОДОЛЖИТЕЛЬНОЙ НОРМАЛЬНОЙ РАБОТЫ:

- Проверить регулятор давления газа и газовый фильтр
- Проверить давление газа с помощью манометра
- Проверить параметры обнаружения пламени (не менее 70 µA)

ГОРЕЛКА НЕ ПЕРЕКЛЮЧАЕТСЯ НА 2-ую (3-ю) СТУПЕНЬ:

- Неправильно выполнено подключение на клеммнике ручного переключателя минимальной и максимальной мощности
- Вышла из строя аппаратура управления
- Катушка электроклапана 2-й (3-й) ступени мощности вышла из строя
- Недостаточное давление дизтоплива
- Засорились фильтры
- Повышенный износ форсунки 2-й (3-й) ступени мощности
- Засорилась форсунка 2-й (3-й) ступени мощности
- Привод воздушной заслонки неисправен либо его необходимо тарировать.

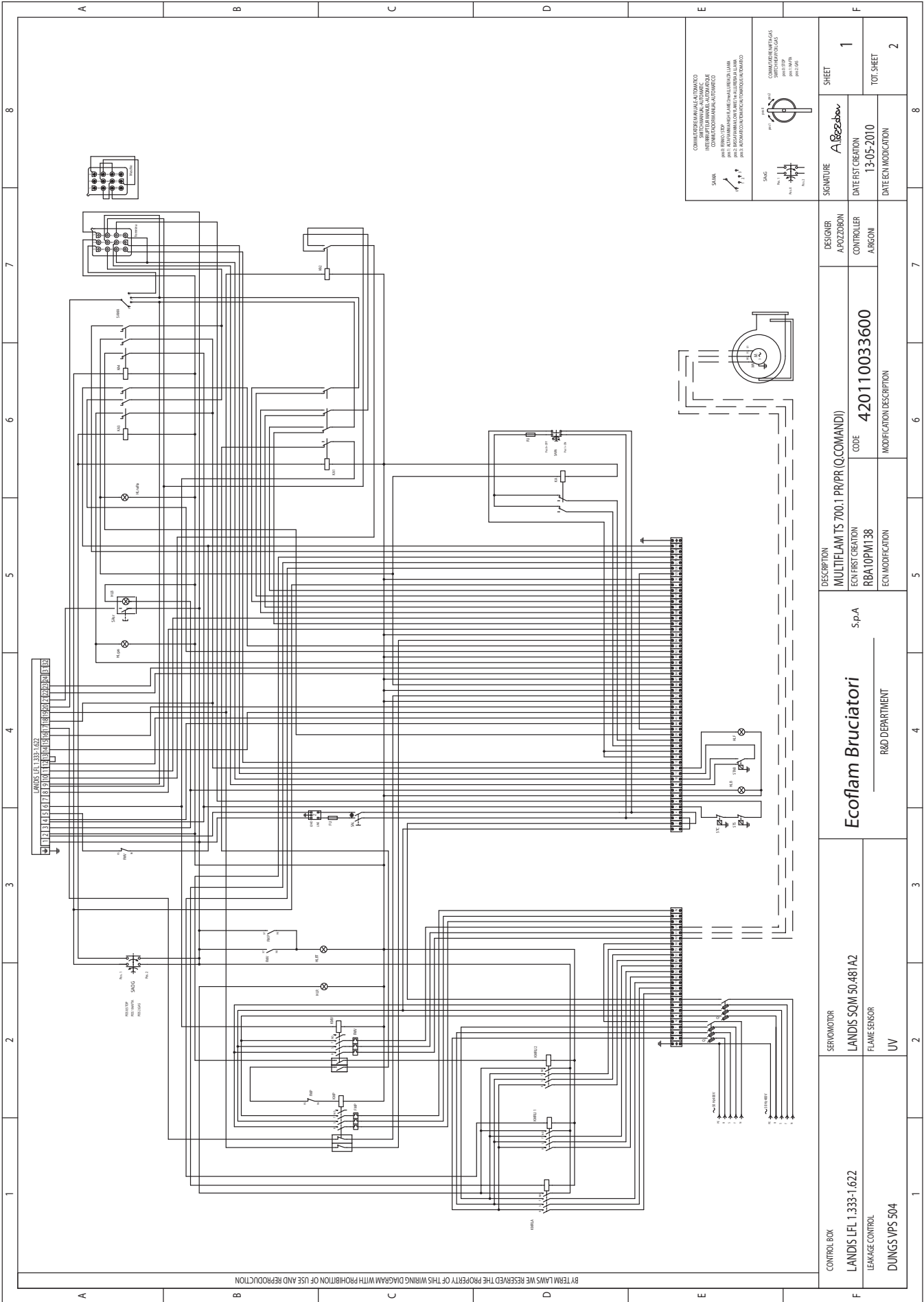

<p>COMPTABILITÀ ANALITICA E TOTALE INTEGRALE DEI MATERIALI AUTOMATICE CONFERITE IN TUTTI I PAESI AUTOMATICE CONFERITE IN TUTTI I PAESI AUTOMATICE IN TUTTI I PAESI AUTOMATICE IN TUTTI I PAESI AUTOMATICE IN TUTTI I PAESI AUTOMATICE IN TUTTI I PAESI AUTOMATICE</p>		<p>SIGNATURE A. Prozzobon</p>	<p>SHEET 1</p>
<p>SIGNATURE A. Prozzobon</p>		<p>DATE FIRST CREATION 13-05-2010</p>	<p>TOT. SHEET 2</p>
<p>DATE EEN MODIFICATION</p>		<p>DATE EEN MODIFICATION</p>	

<p>DESIGNER A. PROZZOBON</p>	<p>CONTROLLER A. PRIGNO</p>
<p>DESCRIPTION MULTIFLAM TS 700.1 PR/PR (COMANDI)</p>	<p>CODE 420110033600</p>
<p>EEN FIRST CREATION RBALOPM138</p>	<p>MODIFICATION DESCRIPTION</p>
<p>Ecoflam Bruciatori S.p.A. R&D DEPARTMENT</p>	
<p>SERVOMOTOR LANDIS SQM 50-481A2</p>	<p>FLAME SENSOR UV</p>
<p>CONTROL BOX LANDIS LEL 1.333-1.622</p>	<p>LEAKAGE CONTROL DUNGS VPS 504</p>

Q		INTERRUTTORE GENERALE CON FUSIBILE GENERAL SWITCH WITH FUSE INTERRUPTEUR GENERAL AVEC FUSIBLE INTERRUPTOR GENERAL CON FUSIBLE	SAGG	INTERRUTTORE A FIAT GAS SWITCH THERMAL GAS INTERRUPTEUR A GAZ INTERRUPTOR A GAZ	8
Z		FILTRO ANTIDISTURBO ANTI-JAMMING FILTER FILTRE ANTIPARASITES FILTRO DE PROTECCION ANTIDISTURBO	KMRLA	CONVATTORE RESISTENZE DI LAVORO WORKING RESISTOR SWITCH INTERRUPTEUR DES RESISTANCES DE TRAVAIL INTERRUPTOR DE LAS RESISTENCIAS DE TRABAJO	7
FU		FUSIBILE FUSE FUSIBLE FUSIBLE	KMRL11	CONVATTORE RESISTENZE DI LAVORO LEVELING RESISTOR SWITCH INTERRUPTEUR DES RESISTANCES DE NIVELEMENT INTERRUPTOR DE LAS RESISTENCIAS DE NIVELACION	6
KA		RELE RELAY RELE RELE	KMRL12	CONVATTORE RESISTENZE DI LAVORO LEVELING RESISTOR SWITCH INTERRUPTEUR DES RESISTANCES DE NIVELEMENT INTERRUPTOR DE LAS RESISTENCIAS DE NIVELACION	5
MV		MOTORE VENTILATORE MOTOR FAN MOTEUR VENTILATEUR MOTORVENTILADOR	KMP	CONVATTORE MOTORE VENTILATORE CONTACTOR MOTOR VENTILATEUR TELEINTERRUPTOR MOTOR VENTILADOR	4
FMP		RELE TERMICO MOTORE POMPA MOTOR PUMP THERMAL RELAY RELE TERMICO MOTORE POMPA RELE TERMICO MOTORE BOMBA	SArz	PULSANTE DI SBLOCCO APPARECCHIATURA RESET LOCK OUT BUTTON INTERRUPTEUR MANUEL COFFRE DE SECURITE SEMANE DE LA CENTRALITA	3
FMV		RELE TERMICO MOTORE VENTILATORE MOTOR FAN THERMAL RELAY RELE TERMICO MOTORE VENTILATEUR RELE TERMICO MOTORE VENTILADOR	HLEB	LAMPADINA BLOCCO TERMICO THERMAL LOCK OUT LAMP LAMPE DE THERMAL DES SECURITE ESPALE DE BLOQUEO RELE TERMICO	2
HLgas		LAMPADINA GAS 1.5T FLAME LAMP LAMPE DE 1.5 ALLURE ESPALE DE 1.5 LLAMA	SAMA	COMUTATORE MANUALE-AUTOMATICO SWITCH MANUAL-AUTOMATIC INTERRUPTEUR MANUEL-AUTOMATIQUE COMUNICADOR MANUAL-AUTOMATICO	1
HLnafa		LAMPADINA FIAT ZAMPARE 2.1 ALLURE ESPALE DE 2.1 LLAMA	SABA	INTERRUTTORE RESISTENZE AUSILIARIE RESISTOR SWITCH AUXILIARIES INTERRUPTEUR RESISTENCIAS AUXILIARES INTERRUPTOR RESISTENCIA AUXILIAR	
HLB		LAMPADINA BLOCCO LOCK OUT LAMP LAMPE DE SECURITE ESPALE DE BLOQUEO			
HLR		LAMPADINA RESISTENZE RESISTOR LAMP ESPALE RESISTENCIAS INDICADOR RESISTENCIAS			
KA1		RELE RELAY RELE RELE			
KA2		RELE RELAY RELE RELE			
KA3		RELE RELAY RELE RELE			
KMP		CONVATTORE MOTORE POMPA PUMP RELAY CONTROL SWITCH CONTACTEUR MOTEUR POMPE EMPALME MOTOR BOMBA			
SAL		INTERRUTTORE DI LINEA WORKING SWITCH INTERRUPTEUR DE LIGNE INTERRUPTOR DE LINGA			
SPA		PRESOSTATO ARIA AIR PRESSURE SWITCH PRESOSTATO AIRE			
STC		TERMOSTATO CALDAIA BOILER THERMOSTAT THERMOSTAT CHAUDIERE THERMOSTATO CALDERA			
STS		TERMOSTATO DI SICUREZZA SAFETY THERMOSTAT THERMOSTAT DE SECURITE THERMOSTATO DE SEGURIDAD			

BY THEM LAMPS WE RESERVED THE PROPERTY OF THIS WIRING DIAGRAM WITH PROHIBITION OF USE AND REPRODUCTION

CONTROL BOX LANDIS IFL1.1.333-1.622		SERVOMOTOR LANDIS SQM50-48/1A2		Ecoflam Bruciatori		DESCRIPTION MULTIFLAM TS 700.1 PR/PR (COMANDI)		DESIGNER A. POZZORON		SIGNATURE A. Pozzoron		SHEET 2	
LEAKAGE CONTROL DUNGS VPS 504		FLAME SENSOR UV		R&D DEPARTMENT		ECN FIRST CREATION RBA10PM138		CONTROLLER A.RIGONI		DATE FIRST CREATION 13-05-2010		TOT. SHEET 2	
						CODE 420110033600				DATE ECN MODIFICATION		MODIFICATION DESCRIPTION	

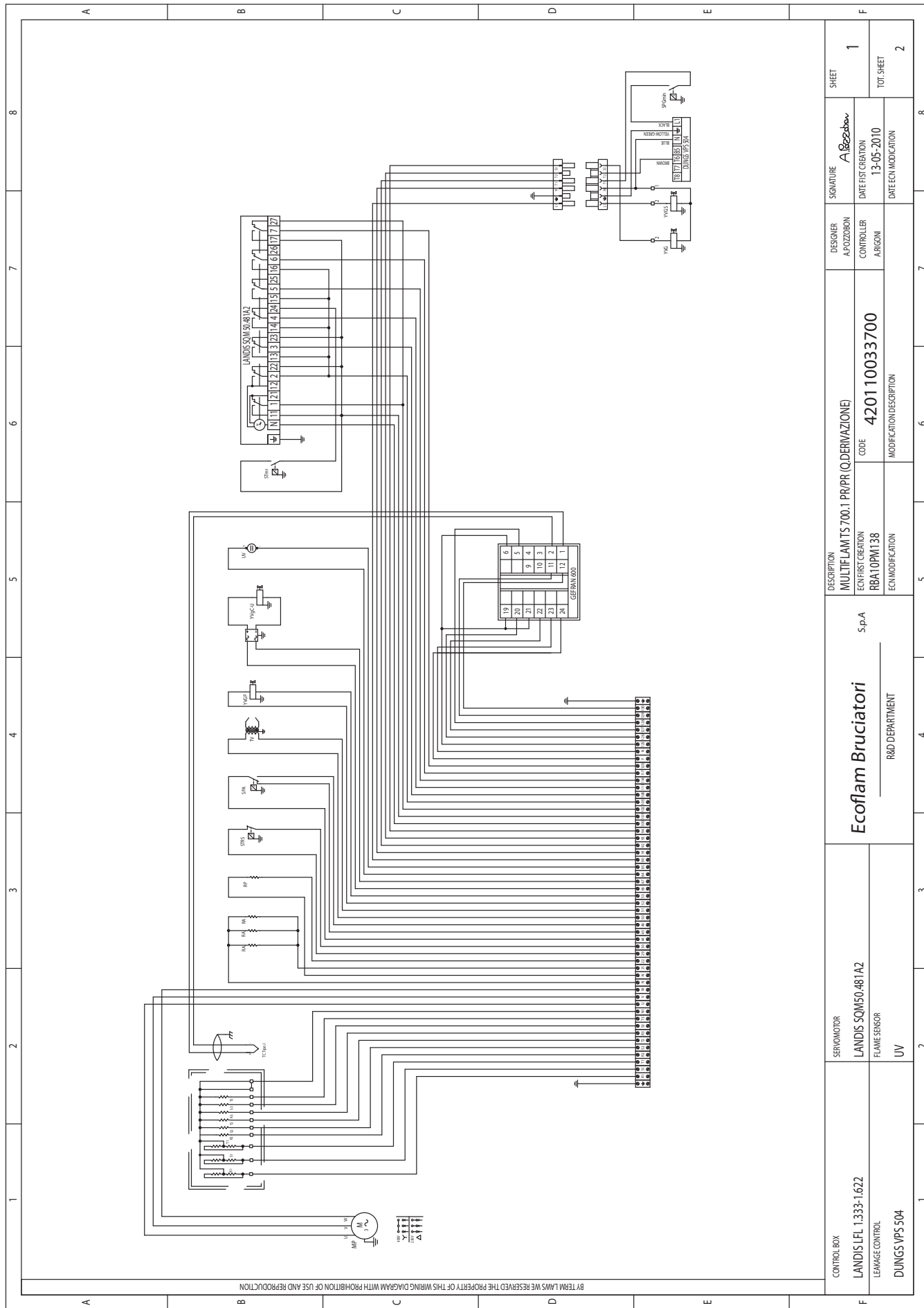

CONTROL BOX LANDIS LFL 1.333-1.622 LEAKAGE CONTROL DUNGS VPS 504	SERVOMOTOR LANDIS SOM50-481 A2 FLAME SENSOR UV	Ecoflam Bruciatori		S.p.A		DESCRIPTION MULTIFLAM TS 700.1 PR/PR (Q.DERIVAZIONE) ECON FIRST CREATION RBA10PMI 38		DESIGNER AFOZORON CONTROLLER ARGONI		SIGNATURE <i>Argon</i> DATE/FIRST CREATION 13-05-2010		SHEET 1	
		R&D DEPARTMENT				ECON MODIFICATION		ARGONI		DATE/ECON MODIFICATION		TOT. SHEET 2	
						CODE 420110033700						8	

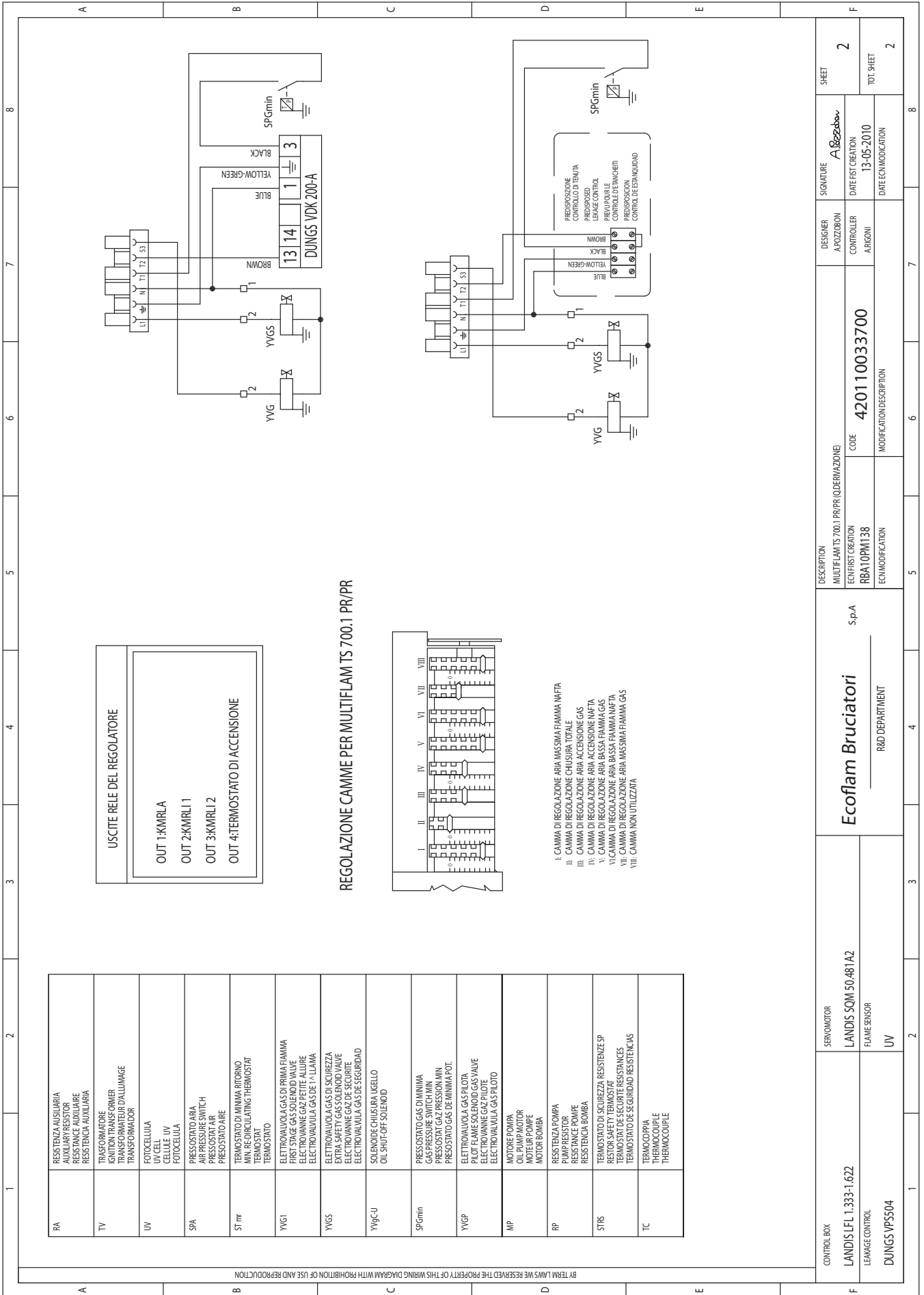

USCITE RELE DEL REGOLATORE

OUT 1: KMRLA
OUT 2: KMRLI 1
OUT 3: KMRLI 2
OUT 4: TERMOSTATO DI ACCENSIONE

REGOLAZIONE CAMME PER MULTIFLAM TS 700.1 PR/PR

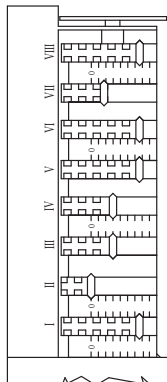

- I: CANNA DI REGOLAZIONE ARIA MASSIMA FIAMMA NAFTA
- II: CANNA DI REGOLAZIONE CHIUSURA TOTALE
- III: CANNA DI REGOLAZIONE ARIA ACCENSIONE GAS
- IV: CANNA DI REGOLAZIONE ARIA ACCENSIONE NAFTA
- V: CANNA DI REGOLAZIONE ARIA BASSA FIAMMA GAS
- VI: CANNA DI REGOLAZIONE ARIA BASSA FIAMMA NAFTA
- VII: CANNA DI REGOLAZIONE ARIA MASSIMA FIAMMA GAS
- VIII: CANNA NON UTILIZZATA

CONTROL BOX	SERVO MOTOR	Ecoflam Bruciatori		DESCRIPTION		DESIGNER	SIGNATURE	SHEET
LANDIS JFL 1.333-1.622	LANDIS SQM 50.481A2	5-p-A		MULTIFLAM TS 700.1 PR/PR (DERIVAZIONE)		A. Rizzobov		2
LEAKAGE CONTROL	FLAME SENSOR	R&D DEPARTMENT		ECON FIRST CREATION		CONTROLLER	DATE/FIRST CREATION	TOT. SHEET
DUNGS VPS504	UV			RBA10PM138		ARGIONI	13-05-2010	2
				ECON MODIFICATION			DATE/ECON MODIFICATION	
				420110033700				
				CODE				
				MODIFICATION DESCRIPTION				
				5				
				6				
				7				
				8				

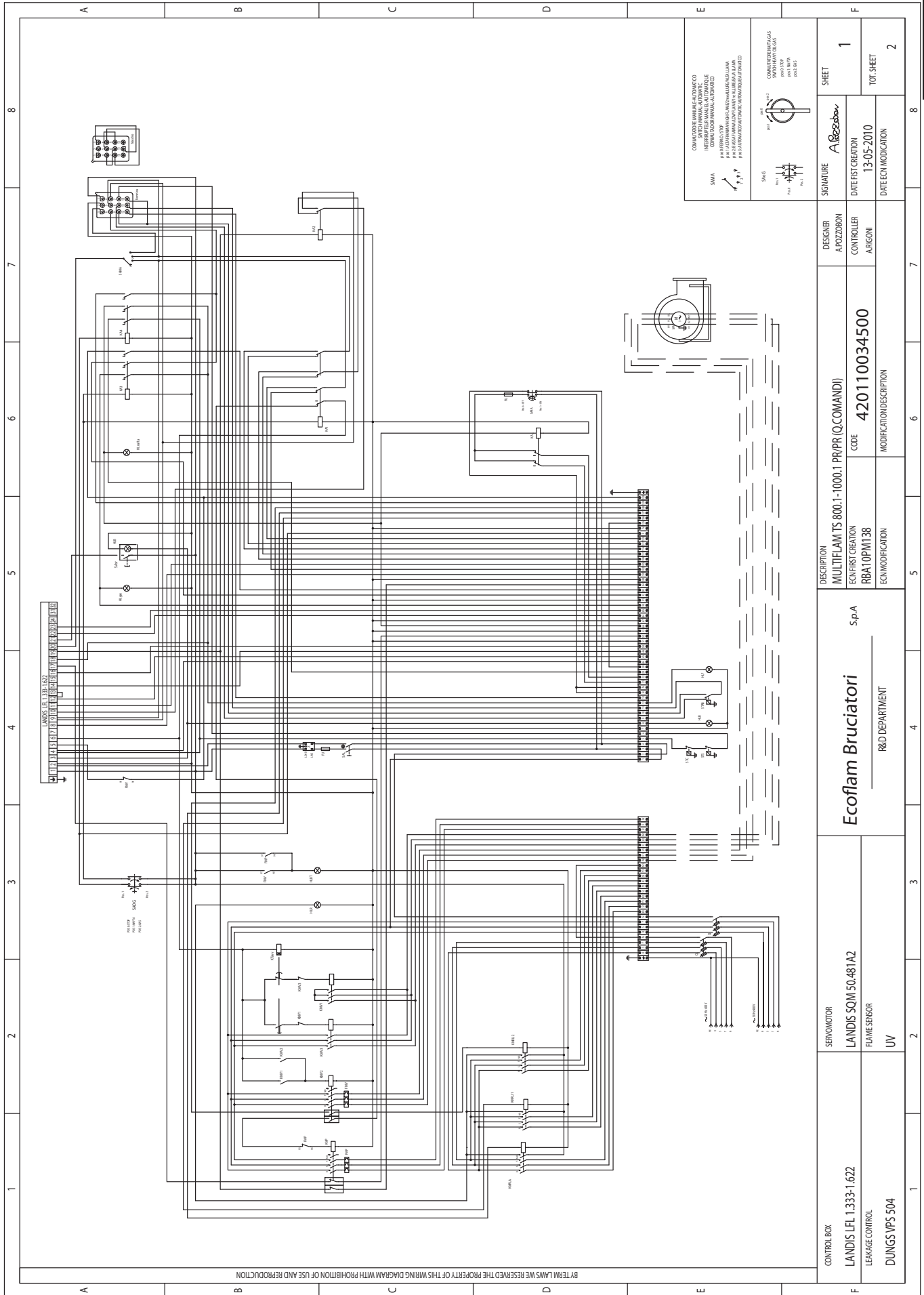

BY TERM LAMS WE RESERVED THE PROPERTY OF THIS WIRING DIAGRAM WITH PROHIBITION OF USE AND REPRODUCTION

CONTROL BOX LANDIS LFL 1.333-1.622 LEAKAGE CONTROL DUNGS VPS 504	SERVO MOTOR LANDIS SQM 50-481A2 FRAME SENSOR UV	Ecoflam Bruciatori		R&D DEPARTMENT	
		s.p.a			
DESCRIPTION MULTIFLAM TS 800.1-1000.1 PR/PR (COMANDI) ECON FIRST CREATION RBA10PMT38		CODE 420110034500	DESCRIPTION MODIFICATION DESCRIPTION	DESIGNER A. BOZZON	CONTROLLER A. BOZZON
		ECON MODIFICATION		SIGNATURE A. Bozzon	SHEET 1
				DATE FIRST CREATION 13-05-2010	TOT. SHEET 2
				DATE ECON MODIFICATION	

Q		INTERUTTORE GENERALE CON FUSIBILE GENERAL PURPOSE FUSIBLE INTERRUPTEUR GENERAL AVEC FUSIBLE GENERAL PURPOSE FUSIBLE	SAOG	INTERUTTORE VAFI GAS GENERAL PURPOSE FUSIBLE INTERRUPTEUR VAFI GAZ GENERAL PURPOSE FUSIBLE	3	4	5	6	7	8
Z		FILTRO ANTIDISTURBO ANTI JAMMING FILTER FILTRE ANTIPARASITES FILTER PROTECTION ANTI-DISTURBO		CONVATORE RESISTENZE DI LAVORO WORKING RESISTOR SWITCH INTERRUPTEUR DES RESISTANCES DE TRAVAIL INTERRUPTEUR DE LAS RESISTENCIAS DE TRABAJO	3	4	5	6	7	8
FU		FUSIBILE FUSE FUSIBLE FUSIBLE	KM1L1	CONVATORE RESISTENZE DI LAVORO WORKING RESISTOR SWITCH INTERRUPTEUR DES RESISTANCES DE TRAVAIL INTERRUPTEUR DE LAS RESISTENCIAS DE TRABAJO	3	4	5	6	7	8
KA		RELE' THERMISTAT THERMISTAT RELAY RELE' THERMISTAT THERMISTAT RELAY	KM1L2	CONVATORE RESISTENZE DI LAVORO WORKING RESISTOR SWITCH INTERRUPTEUR DES RESISTANCES DE TRAVAIL INTERRUPTEUR DE LAS RESISTENCIAS DE TRABAJO	3	4	5	6	7	8
MV		MOTORE VENTILATORE MOTOR FAN MOTEUR VENTILATEUR MOTOR VENTILADOR	KM1	CONVATORE DI STELLA STAR CONTACTOR CONTACTEUR D'ETOILE CONTACTOR DE ESTRELLA	3	4	5	6	7	8
FMP		RELE' TERMICO MOTORE POMPA MOTOR PUMP THERMAL RELAY RELAS TERMICO MOTER POMP RELE' TERMICO MOTOR BOMBA	KM2	CONVATORE MOTORE VENTILATORE REMOTE CONTROL SWITCH (FAN MOTOR) CONTACTEUR MOTEUR VENTILATEUR TELECOMANDO VENTILADOR	3	4	5	6	7	8
FMY		RELE' TERMICO MOTORE VENTILATORE MOTOR FAN THERMAL RELAY RELAS TERMICO MOTER VENTIL RELE' TERMICO MOTOR VENTILADOR	KM3	CONVATORE DI TRIANGOLO TRIANGLE CONTACTOR CONTACTEUR TRIANGLE CONTACTOR DE TRIANGULO	3	4	5	6	7	8
HLg6		LAMPADA GAS 1.5T FLAME LAMP LAMPE DE 1 ^o ALLURE ESPA DE 1 ^o LLAMA	SA61	FUSANTE DI BLOCCO APPARECCHIATURA RESET LOCK OUT BUTTON BOUON DE BLOCCAGE DU COFFRE DE SECURITE REARME DE LA CENTRALITA	3	4	5	6	7	8
HLnd6		LAMPADA MFTA 2.5T FLAME LAMP LAMPE DE 2 ^o ALLURE ESPA DE 2 ^o LLAMA	HLBT	LAMPADA DI BLOCCO TERMICO THERMAL LOCK-OUT LAMP LAMPE DE THERMAL DE SECURITE ESPA DE BLOCCO RELE TERMICO	3	4	5	6	7	8
HLB		LAMPADA DI BLOCCO THERMAL LOCK-OUT LAMP LAMPE DE BLOCCO ESPA DE BLOQUEO	SAMA	COMUTATORE MANUALE AUTOMATICO SWITCH MANUAL AUTOMATICO CONTACTEUR MANUEL AUTOMATIQUE COMUTADOR MANUAL AUTOMATICO	3	4	5	6	7	8
HLR		LAMPADA RESISTENZE RESISTOR LAMP THERMION RESISTENCES INDICADOR RESISTENCIAS	SBA	INTERUTTORE RESISTENZE AUSILIARIE INTERRUPTEUR RESISTENCIA AUXILIAR	3	4	5	6	7	8
KA1		RELE' RELAY RELAS RELE'			3	4	5	6	7	8
KA2		RELE' RELAY RELAS RELE'			3	4	5	6	7	8
KA3		RELE' RELAY RELAS RELE'			3	4	5	6	7	8
KMP		CONVATORE MOTORE POMPA PUMP REMOTE CONTROL SWITCH CONTACTEUR MOTEUR POMP EMPALME MOTOR BOMBA			3	4	5	6	7	8
SAL		INTERUTTORE DI LINEA WORKING SWITCH CONTACTEUR DE LIGNE INTERRUPTEUR DE LINEA			3	4	5	6	7	8
SHB		TERMOSTATO A BASSA CALORIA HIGH LOW FLAME THERMOSTAT THERMOSTAT GRANDE PÉTITE ALLURE THERMOSTATO DE ALTA-BAJA LLAMA			3	4	5	6	7	8
STC		TERMOSTATO CALDAIA BOILER THERMOSTAT THERMOSTAT CHAUDIERE THERMOSTATO CALDERA			3	4	5	6	7	8
ST5		TERMOSTATO DI SICUREZZA SAFETY THERMOSTAT THERMOSTATO DE SEGURIDAD			3	4	5	6	7	8

BY TERM FLAMS WE RESERVE THE PROPERTY OF THIS WIRING DIAGRAM WITH PROHIBITION OF USE AND REPRODUCTION

CONTROL BOX LANDIS LFL 1.333-1.622		SERVO MOTOR LANDIS SQM50481A2	Ecoflam Bruciatori S.p.A		MULTIFLAM TS 800.1-1000.1 PR/PR (COMANDI)		SIGNATURE A. Pozzobon		SHEET 2	
LEAKAGE CONTROL DUNGS VPS 504		FLAME SENSOR UV	R&D DEPARTMENT		CODE 420110034500		DESIGNER A. POZZOBON		DATE EST CREATION 13-05-2010	
					MODIFICATION DESCRIPTION		CONTROLLER A. RIGONI		DATE ECO MODIFICATION 2	
									TOT. SHEET 2	

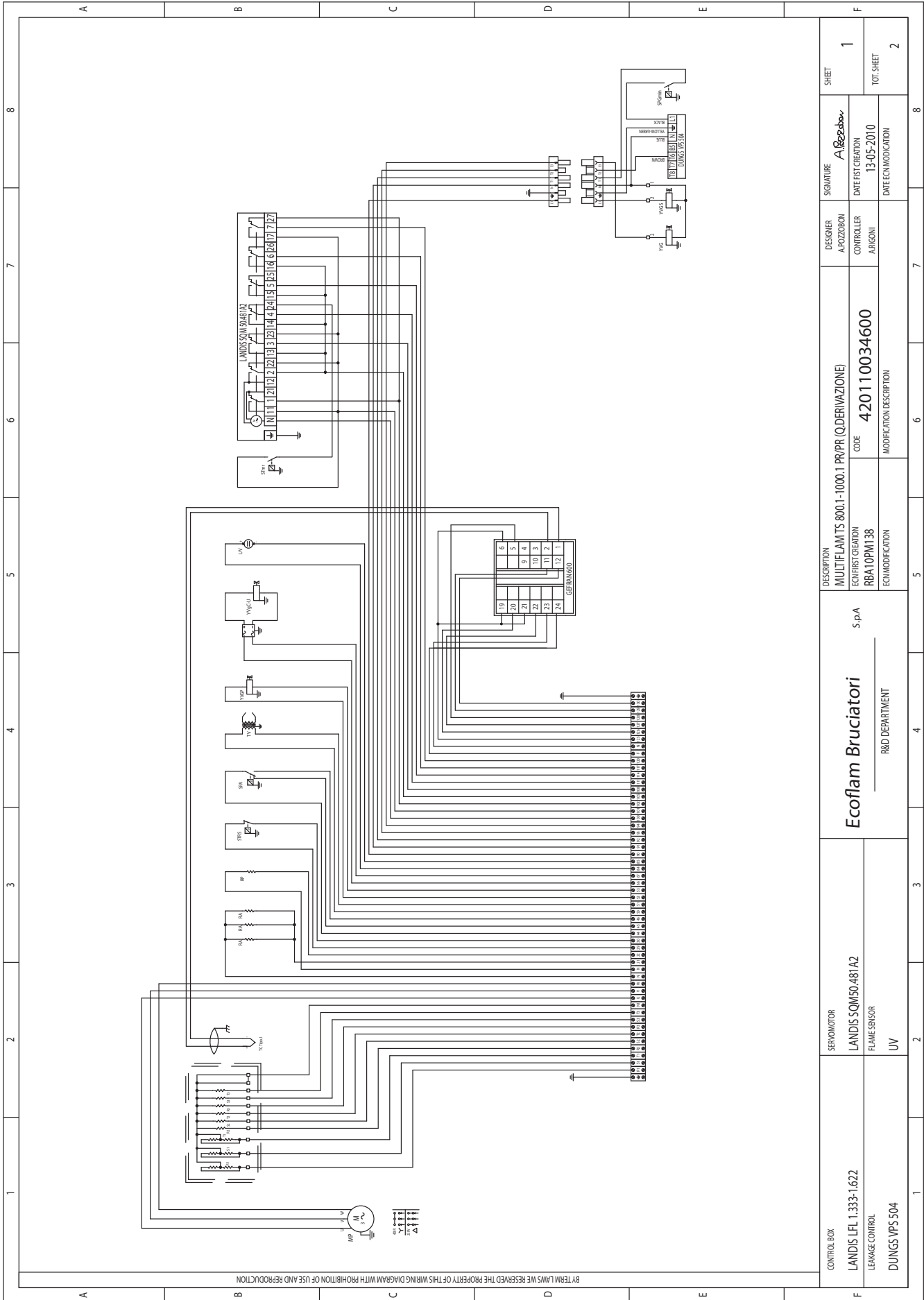

CONTROL BOX LANDIS LFL 1.333-1.622 LEAKAGE CONTROL DUNGS VPS 504	SERVOMOTOR LANDIS SQM50.481A2 FLAME SENSOR UV	Ecoflam Bruciatori		S.p.A		DESCRIPTION MULTIFLAM TS 800.1 - 1000.1 PR/PR (Q.DERIVAZIONE) ECON FIRST CREATION RBA10PM138		DESIGNER A. POZZORON	SIGNATURE A. Bezzabov	SHEET 1
		R&D DEPARTMENT				ECN MODIFICATION		CONTROLLER A. RIZONI	DATE FIRST CREATION 13-05-2010	TOT. SHEET 2
						ECN MODIFICATION				

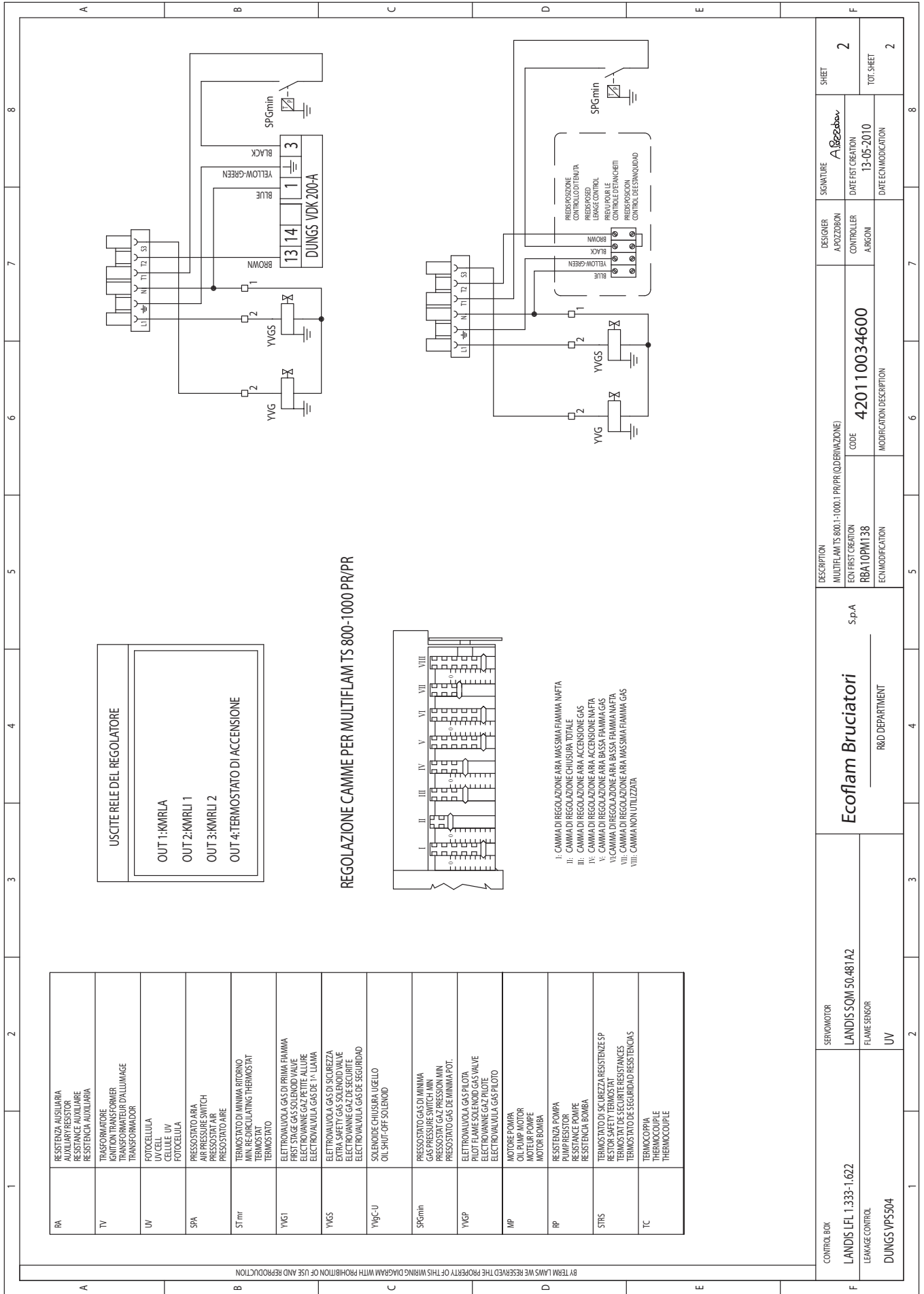

USCITE RELE DEL REGOLATORE

OUT 1: KMRLA
OUT 2: KMRLI 1
OUT 3: KMRLI 2
OUT 4: TERMOSTATO DI ACCENSIONE

REGOLAZIONE CAMME PER MULTIFLAM TS 800-1000 PR/PR

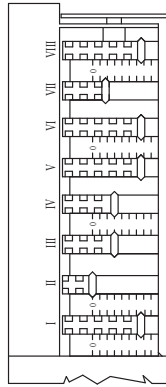

- I: CAMMA DI REGOLAZIONE ARIA MASSIMA FIAMMA NAFTA
- II: CAMMA DI REGOLAZIONE CHIUSURA TOTALE
- III: CAMMA DI REGOLAZIONE ARIA ACCENSIONE GAS
- IV: CAMMA DI REGOLAZIONE ARIA ACCENSIONE NAFTA
- V: CAMMA DI REGOLAZIONE ARIA BASSA FIAMMA GAS
- VI: CAMMA DI REGOLAZIONE ARIA BASSA FIAMMA NAFTA
- VII: CAMMA DI REGOLAZIONE ARIA MASSIMA FIAMMA GAS
- VIII: CAMMA NON UTILIZZATA

RA	RESISTENZA AUSILIARIA AUXILIARY RESISTOR RESISTANCE AUXILIAIRE RESISTENCIA AUXILIARIA
TV	TRASFORMATORE IGNITION TRANSFORMER TRANSFORMATEUR D'ALLUMAGE TRANSFORMADOR
UV	FOTOCELLULA CELLULE UV FOTOCELULA
SPA	PRESSOSTATO ARIA AIR PRESSURE SWITCH PRESSOSTAT AIR PRESSOSTATO AIRE
STmr	TERMOSTATO DI MINIMA RITORNO MIN. RE-CIRCULATING THERMOSTAT TERMOSTAT TERMOSTATO
YVGI	ELETTROVALVOLA GAS DI PRIMA FIAMMA FIRST STAGE GAS SOLENOID VALVE ELECTROVANNE GAZ PETITE ALLURE ELECTROVALVULA GAS DE 1 ^a LLAMA
YVGS	ELETTROVALVOLA GAS DI SICUREZZA EXTRA SURETY GAS SOLENOID VALVE ELECTROVANNE GAZ DE SECURITE ELECTROVALVULA GAS DE SEGURIDAD
YVg-U	SOLENOIDE CHIUSURA UGELLO OIL SHUT-OFF SOLENOID
SPGmin	PRESSOSTATO GAS DI MINIMA GAS PRESSURE SWITCH MIN PRESSOSTAT GAZ PRESSION MIN PRESSOSTATO GAS DE MINIMA POT.
YVGP	ELETTROVALVOLA GAS PILOTA PILOT FLAME SOLENOID GAS VALVE ELECTROVANNE GAZ PILOTE ELECTROVALVULA GAS PILOTO
MP	MOTORE POMPA OIL PUMP MOTOR MOTELR POMPE MOTOR BOMBA
RP	RESISTENZA POMPA PUMP RESISTOR RESISTANCE POMPE RESISTENCIA BOMBA
STRS	TERMOSTATO SICUREZZA RESISTENZE SP RESISTANCE THERMOCOUPLE TERMOSTAT DE SECURITE RESISTENCIAS TERMOSTATO DE SEGURIDAD RESISTENCIAS
TC	TERMOCOPIA THERMOCOUPLE TERMOCOUPLE

CONTROL BOX	SERVOMOTOR	Ecoflam Bruciatori		DESCRIPTION		DESIGNER	SIGNATURE	SHEET
LANDIS SQM 1.333-1.622	LANDIS SQM 50.481A2	5 p.A	MULTIFLAM TS 800.1-1000.1 PR/PR (ODERWAZUNG)	420110034600	ECO FIRST CREATION	AROZZON	A. Bazzobon	2
LEAKAGE CONTROL	FLAME SENSOR		RBA10PM138	CODE	RBA10PM138	CONTROLLER	DATE FST CREATION	TOT. SHEET
DUNGS VPS504	UV	R&D DEPARTMENT	ECN MODIFICATION	MODIFICATION DESCRIPTION	13-05-2010	ARGONI	DATE ECN MODIFICATION	2

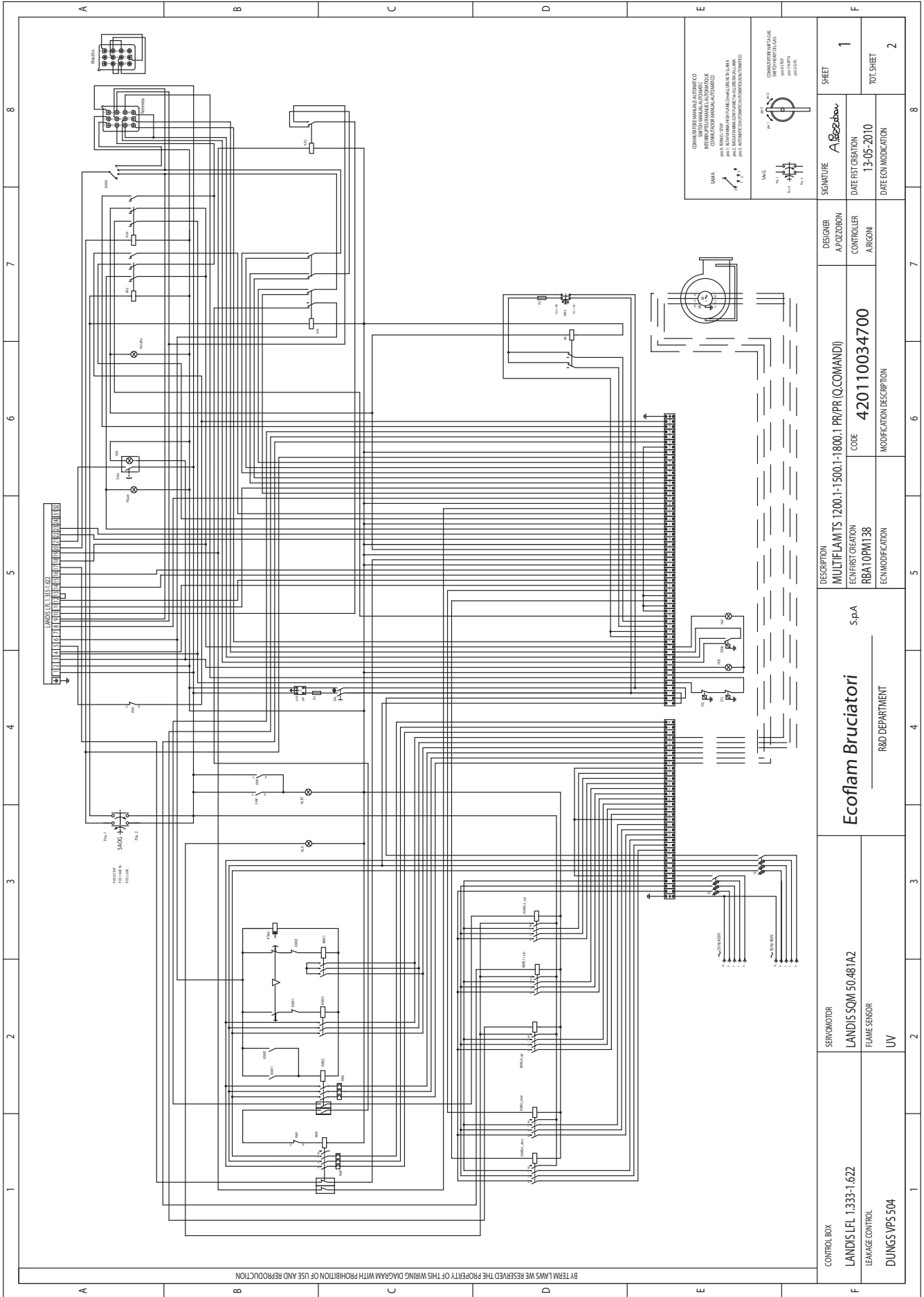

BY TBM LWS WE RESERVE THE PROPERTY OF THIS WIRING DIAGRAM WITH PROHIBITION OF USE AND REPRODUCTION

CONTROL BOX LANDIS JFL 1.333-1.622 LEAKAGE CONTROL DUNGS VPS 504	SERVOMOTOR LANDIS SQM 50.481A2 FLAME SENSOR UV	Ecoflam Bruciatori R&D DEPARTMENT		S.p.A	DESCRIPTION MULTIFLAM TS 1200.1 - 1500.1 - 1800.1 PR/PR (Q.COMANDI) ECON FIRST CREATION RBA10PMT38 ECON MODIFICATION	DESIGNER A.POZZOBON CONTROLLER A.BIGNONI	SIGNATURE <i>A. Pozzobon</i> DATE FIRST CREATION 13-05-2010 DATE ECON MODIFICATION	SHEET 1 TOT SHEET 2
					CODE 420110034700 MODIFICATION DESCRIPTION			

1		2		3		4		5		6		7		8	
Q	INTERRUTTORE GENERALE CON FUSIBILE MAIN SWITCH WITH FUSE INTERRUPTEUR GENERAL AVEC FUSIBLE INTERRUPTOR GENERAL CON FUSIBLE	SAL	INTERRUTTORE DI LINEA WORKING SWITCH INTERRUPTEUR DE LIGNE INTERRUPTOR DE LINEA												
Q1	INTERRUTTORE GENERALE CON FUSIBILE MAIN SWITCH WITH FUSE INTERRUPTEUR GENERAL AVEC FUSIBLE INTERRUPTOR GENERAL CON FUSIBLE	STC	TERMOSTATO CALORIA BOILER THERMOSTAT THERMOSTAT CHAUDIERE THERMOSTATO CALDERA												
Z	FILTRO ANTIDISTURBO ANTI-JAMMING FILTER FILTRE ANTI-DISTURBO ANTI-DISTRUBO	STS	TERMOSTATO DI SICUREZZA SAFETY THERMOSTAT THERMOSTAT DE SECURITE THERMOSTATO DE SEGURIDAD												
FU	FUSIBILE FUSE FUSIBLE FUSIBLE	SIAG	INTERRUTTORE ON/OFF GAS SWITCH HEAVY ON/OFF GAS INTERRUPTEUR POUR LE LOURD - GAZ INTERRUPTOR PARA CETE RESMO - GAZ												
KA	RELE RELAY RELE RELE	STBB	TERMOSTATO DI ALTA-BASSA FUMMA HIGH/LOW FLAME THERMOSTAT THERMOSTAT DE HAUTE/BASSE FUMEE THERMOSTATO DE ALTA/BAJA LLAMA												
KAI	RELE RELAY RELE RELE	K10w	TEMPORIZZATORE ELETTRONICO A SETTLARING ELECTRONIC TIME WITH SETTLARING STARTER TEMPORIZADOR ELECTRONICO PREPARADO PARA TEMPORIZADOR ELECTRONICO PREPARADO PARA RESET LOCK OUT BUTTON												
KA2	RELE RELAY RELE RELE	SAur	PULSANTE DI SILECCO APPARECCHIATURA RESET LOCK OUT BUTTON												
KAS	RELE RELAY RELE RELE	KARLA_up	CONVATTORE RESISTENZE LAVORO BARILLOTO SUPERIORE HEAVY BARREL UPPER WORKING RESISTORS REMOTE CONTROL SWITCH												
KA4	RELE RELAY RELE RELE	KARLI_up	CONVATTORE RESISTENZE LIVELAMENTO BARILLOTO INTERIORE HEAVY BARREL DOWN LEVELLING RESISTORS REMOTE CONTROL SWITCH												
FMP	RELE TERMICO MOTORE POMPA MOTOR THERMAL RELAY RELE TERMICO MOTORE POMPA RELE TERMICO MOTORE BOMBA	KARLI2_up	CONVATTORE RESISTENZE LIVELAMENTO BARILLOTO INTERIORE HEAVY BARREL DOWN LEVELLING RESISTORS REMOTE CONTROL SWITCH												
FMV	RELE TERMICO MOTORE VENTILATORE MOTOR THERMAL RELAY FAN MOTOR RELE TERMICO MOTORE VENTILADOR RELE TERMICO MOTORE VENTILADOR	KARLA_down	CONVATTORE RESISTENZE LAVORO BARILLOTO INFERIORE HEAVY BARREL DOWN WORKING RESISTORS REMOTE CONTROL SWITCH												
HLgs	LAMPADA GAS LST FLAME LAMP LAMPE DE 1° ALLURE ESPA DE 1° LLAMA	KARLI_down	CONVATTORE RESISTENZE LIVELAMENTO BARILLOTO INTERIORE HEAVY BARREL DOWN LEVELLING RESISTORS REMOTE CONTROL SWITCH												
HLmba	LAMPADA NAFTA 25 FLAME LAMP LAMPES DE 2° ALLURE ESPA DE 2° LLAMA	SARA	INTERRUTTORE RESISTENZE AUSILIARE AUX HEATER SWITCH INTERRUPTEUR RESISTENCES AUXILIAIRES INTERRUPTOR RESISTENCIA AUXILIAR												
HLB	LAMPADA FUOCO LOCK-OUT LAMP LAMPES DE SECURITE ESPA DE BLOQUEO	SAMA	CONVATTORE MANUALE AUTOMATICO INTERRUPTEUR MANUEL-AUTOMATIQUE CONVULSOR MANUAL-AUTOMATICO												
HLR	LAMPADA RESISTENZE RESISTOR LAMP LAMPES DE RESISTENCES INDIC. ADDRESS RESISTENCIAS	MV	MOTORE VENTILATORE MOTOR FAN MOTEUR VENTILATEUR MOTOR VENTILADOR												
RMP	CONVATTORE MOTORE POMPA PUMP REMOTE CONTROL SWITCH CONVATEUR MOTEUR POMPE EMPALME MOTOR BOMBA	HLBT	LAMPADA DI SICUREZZA TERMICO THERMAL LOCK-OUT LAMP LAMPES DE THERMAL DE SECURITE ESPA DE BLOQUEO RELE TERMICO												
RMV1	CONVATTORE DI STELLA STAR CONTACTOR CONVATEUR DE STELLA CONVATTORE DE STELLA														
RMV2	CONVATTORE MOTORE VENTILATORE RE MOTORE CONTROL SWITCH FAN MOTOR CONVATEUR MOTEUR VENTILATEUR TELEINTERRUPTOR MOTOR VENTILATOR														
RMV3	CONVATTORE DI TRIANGOLO DELTA CONTACTOR CONVATEUR DE TRIANGLE CONVATTORE DI TRIANGOLO														
CONTROL BOX LANDIS IFL 1.333-1.622 LEAKAGE CONTROL DUNGS IFS 504		SERVOMOTOR LANDIS SOM50.481A2 FLAME SENSOR UV	Ecoflam Bruciatori S.p.A R&D DEPARTMENT			DESCRIPTION MULTIFLAM TS 1200.1-1500.1-1800.1 PR/PR (Q.COMANDI) EON FIRST CREATION RBA10PMI 38 EON MODIFICATION			DESIGNER ALAZORON CONTROLLER A.RIGONI		SIGNATURE A. Rigoni	SHEET 2		TOT. SHEET 2	

BY TERM LAMWS WE RESERVE THE PROPERTY OF THIS WIRING DIAGRAM WITH PROHIBITION OF USE AND REPRODUCTION

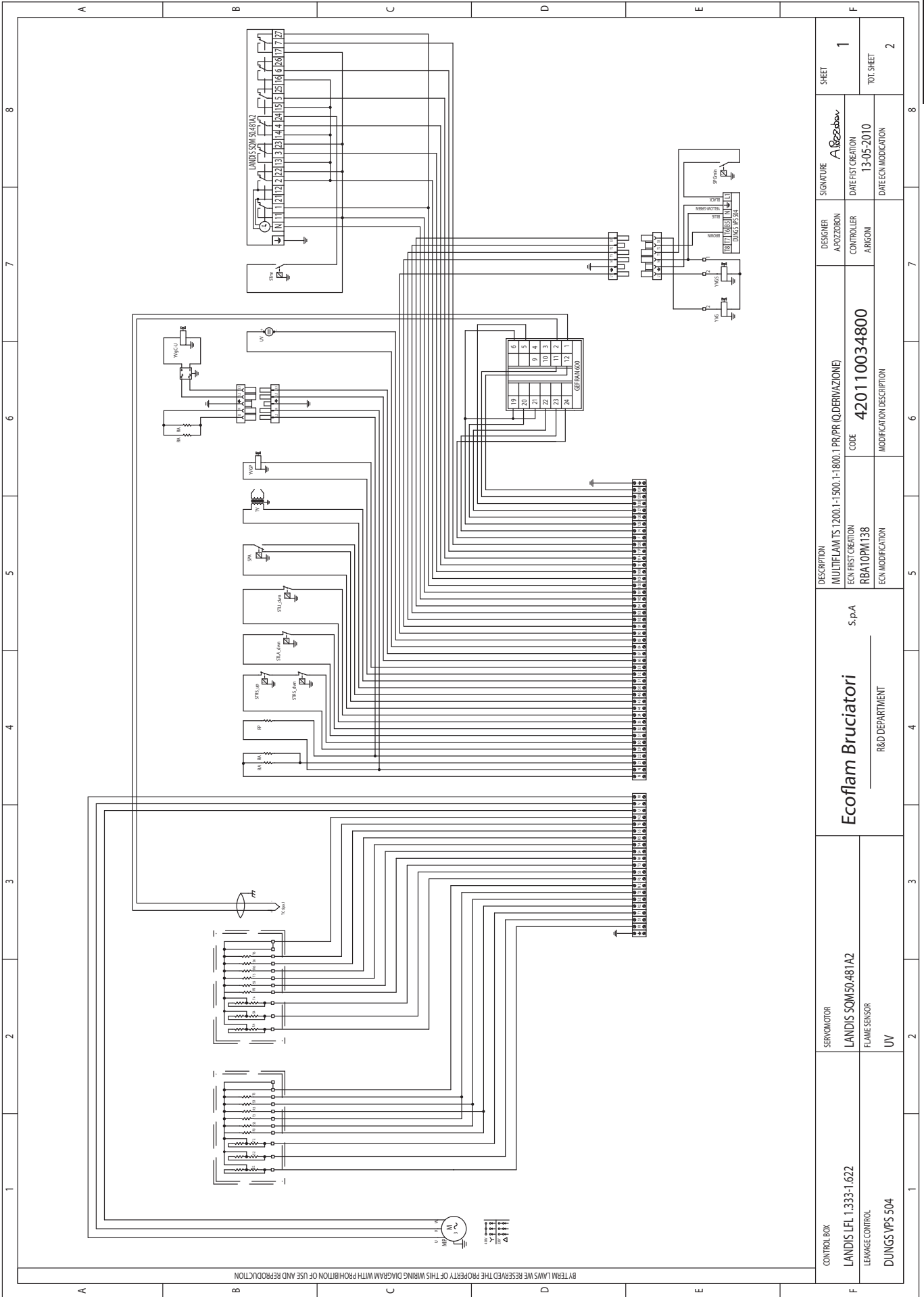

CONTROL BOX LANDIS LEF 1.333-1.622 LEAKAGE CONTROL DUNGS VPS 504	SERVOMOTOR LANDIS SOM50.481A2	Ecoflam Bruciatori		MULTIFLAM TS 1200.1-1500.1-1800.1 PR/PR (Q.DERIVAZIONE)		DESIGNER ARZOBONI	SIGNATURE A. Argonov	SHEET 1
	FLAME SENSOR UV	S.p.A	CODE 4201 10034800	ECON FIRST CREATION RBA10PM138	MODIFICATION DESCRIPTION	CONTROLLER ARGONOV	DATE/FIRST CREATION 13-05-2010	TOT. SHEET 2
R&D DEPARTMENT		R&D DEPARTMENT		R&D DEPARTMENT		DATE/ECON MODIFICATION		8

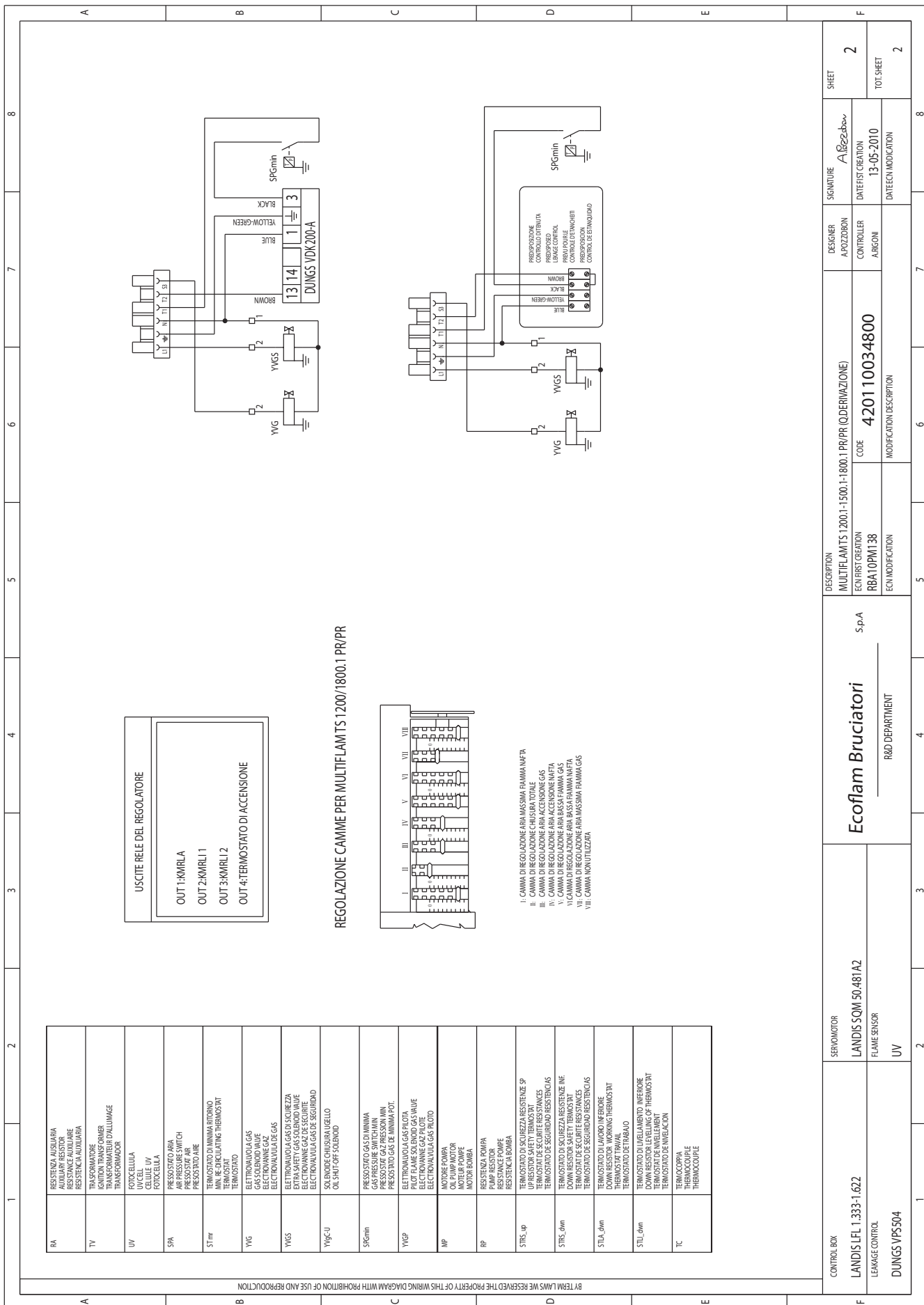

DESIGNER: A. Beccabon
CONTROLLER: A. BEGONI
DATE/FIRST CREATION: 13-05-2010
DATE/TECH MODIFICATION: 2

DESCRIPTION: MULTIFLAMTS 1200.1-1500.1-1800.1 PR/PR (Q DERIVAZIONE)
ECON FIRST CREATION CODE: 420110034800
ECON MODIFICATION: RBA10PM138
MODIFICATION DESCRIPTION: 2

Ecoflam Bruciatori
S.p.A
R&D DEPARTMENT

LANDIS SOM 50.481A2
FLAME SENSOR
UV

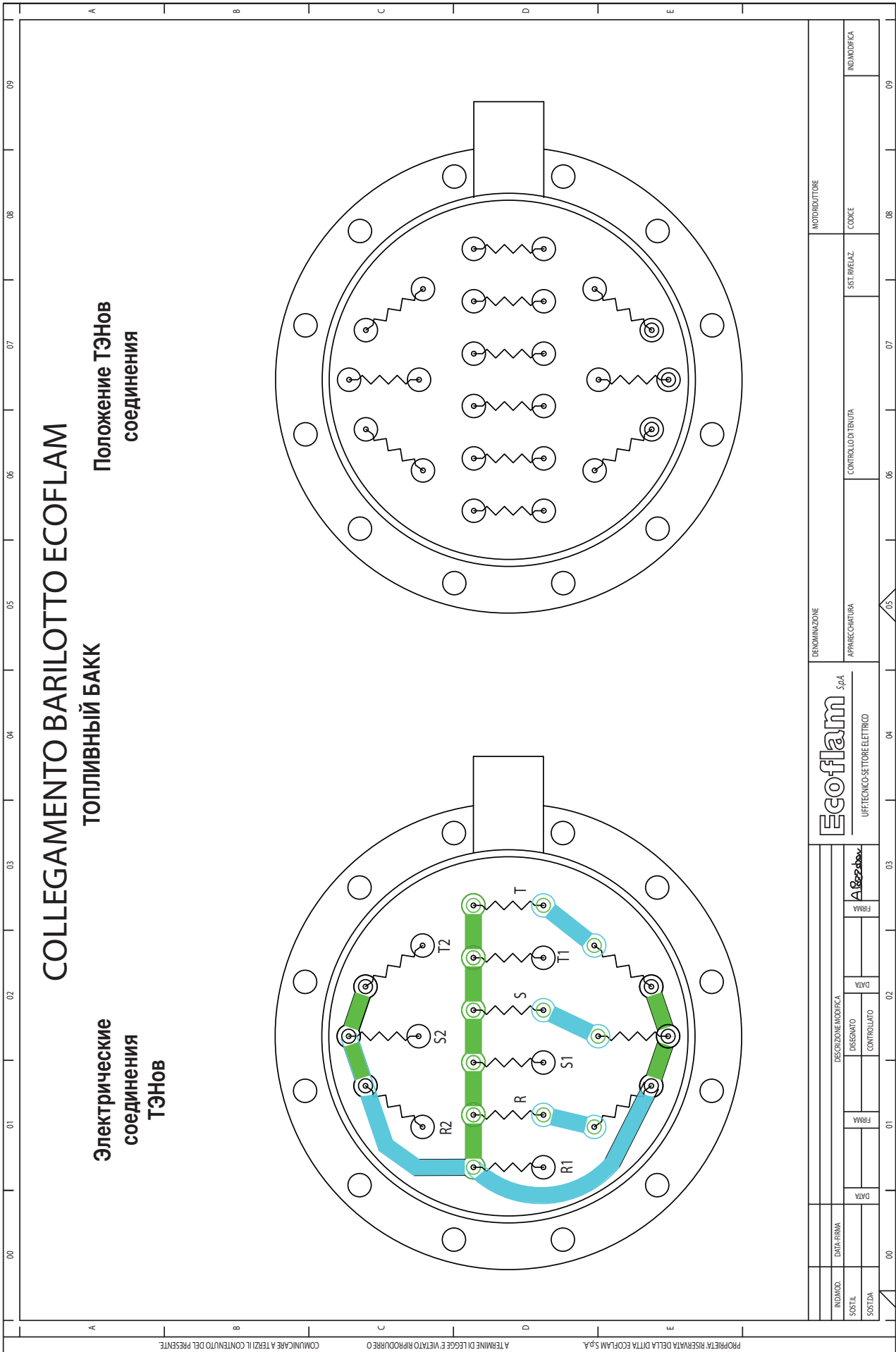

La ECOFLAM BRUCIATORI S.p.A si riserva il diritto di apportare ai prodotti quelle modifiche che riterrà necessarie o utili, senza pregiudicarne le caratteristiche principali.

ECOFLAM BRUCIATORI S.p.A. reserves the right to make any adjustments, without prior notice, which it considers necessary or useful to its products, without affecting their main features.

La Maison ECOFLAM BRUCIATORI S.p.A. se réserve le droit d'apporter les modifications qu'elle jugera nécessaires ou utiles à ses produits sans pour autant nuire à leurs caractéristiques principales.

ECOFLAM BRUCIATORI S.p.A. se reserva el derecho a introducir en sus productos todas las modificaciones que considere necesarias o utiles, sin perjudicar sus características.

"Экофлам С.п.А." оставляет за собой право вносить в конструкцию оборудования любые необходимые изменения без особого предупреждения.

Ecoflam

Ecoflam Bruciatori S.p.A.

via Roma, 64 - 31023 RESANA (TV) - Italy - tel. 0423.719500 - fax 0423.719580

<http://www.ecoflam-burners.com> - e-mail: export@ecoflam-burners.com