

UTOPIA IVX PREMIUM / IVX STANDARD SERIES
H(V)N(P/C)(E)

Service Manual

RAS-(2-6)HVNP(E)
RAS-(4-12)HNP(E)

RAS-(3-6)HVNC(E)
RAS-(4-12)HNC(E)

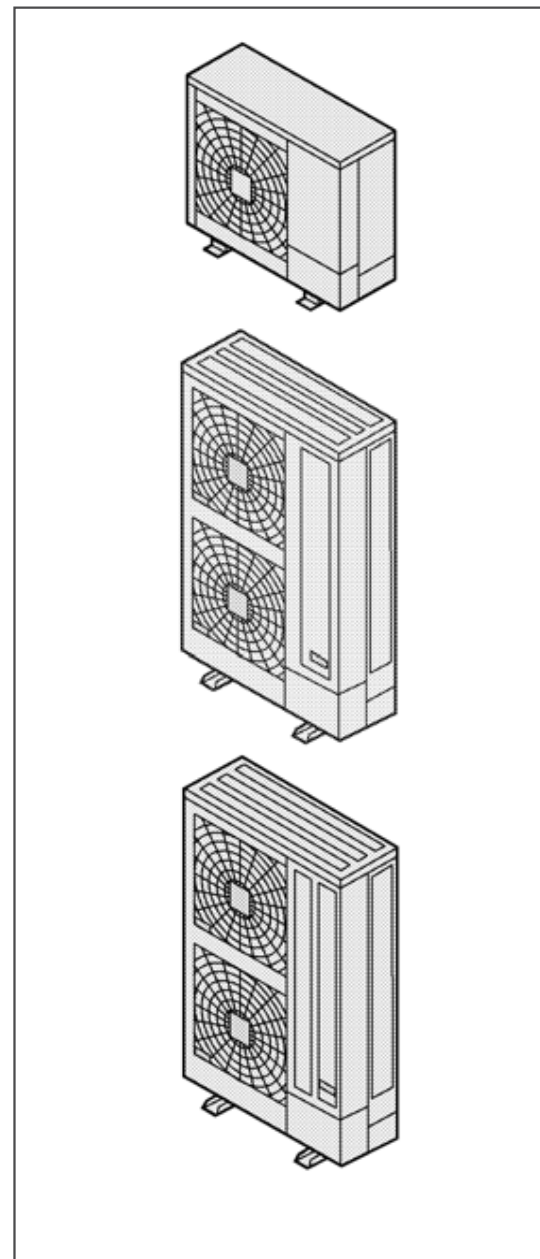

Contents

General information	1
Unit Installation	2
Piping work and refrigerant charge	3
Electrical Wiring	4
Control System	5
Optional functions	6
Test Run	7
Troubleshooting	8
Spare Parts	9
Servicing	10
Electrical checks of main parts	11
Maintenance notes	12

Index

Contents	i
1. General information	1
1.1 General information	2
1.1.1 General notes	2
1.1.2 Introduction	2
1.1.3 Environment-friendly units	2
1.2 Safety	3
1.2.1 Applied symbols	3
1.2.2 Norms and Regulations	3
1.3 Product guide	4
1.3.1 Classification of outdoor unit models	4
1.3.2 Classification of indoor unit models	4
1.3.3 Product guide: Outdoor units	5
1.3.4 Outdoor unit accessory code list	6
1.3.5 Product guide: Indoor units & complementary systems	7
1.3.6 Product guide: complementary systems	10
2. Unit Installation	13
2.1 Safety summary	14
2.2 Transportation of outdoor unit	15
2.3 Center of gravity	16
2.4 Factory-supplied accessories for RAS-12HN(P/C)	17
2.5 Installation space (Initial ckeck)	18
2.5.1 Basic sizes	18
2.5.2 RAS-(2-2.5)HVNP / RAS-3HVNC	19
2.5.3 RAS-3HVNPE / RAS-(4-6)H(V)N(P/C)E / RAS-(8-10)HN(P/C)E / RAS-12HN(P/C)	20
2.6 Place provision	23
2.6.1 Place provision for RAS-(2-2.5)HVNP / RAS-3HVNC	23
2.6.2 Place provision for RAS-3HVNPE / RAS-(4-6)H(V)N(P/C)E / RAS-(8-10)HN(P/C)E / RAS-12HN(P/C)	25
2.7 Optional parts and installation	29
2.7.1 Optional parts and installation for RAS-(2-2.5)HVNP / RAS-3HVNC	29
2.7.2 Optional parts and installation RAS-3HVNPE / RAS-(4-6)H(V)NCE	34
2.7.3 Optional parts and installation RAS-(4-6)H(V)NPE / RAS-(8-10)HN(P/C)E	39
2.7.4 Optional parts and installation RAS-12HN(P/C)	45

3. Piping work and refrigerant charge	51
3.1 General notes before performing pipe work	52
3.1.1 Piping Materials	52
3.1.2 Three principles on refrigerant piping work	54
3.1.3 Suspension of refrigerant piping	54
3.1.4 Brazing work	55
3.2 Piping connection for outdoor unit	56
3.2.1 RAS-(2-2.5)HVNP / RAS-3HVNC	56
3.2.2 RAS-3HVNPE / RAS-(4-6)H(V)N(P/C)E / RAS-(8-10)HN(P/C)E / RAS-12HN(P/C)	57
3.2.3 Outdoor unit stop valve	60
3.3 Refrigerant piping range	62
3.3.1 Refrigerant piping length	62
3.3.2 Piping system for header branch	62
3.3.3 Piping system for line branch	65
3.3.4 Combinations of piping size and piping length	66
3.3.5 Refrigerant piping size and multikit/distributor selection	67
3.3.6 System installation	70
3.3.7 Connecting flare adapter	71
3.4 Refrigerant charge	72
3.4.1 Caution of the pressure by check joint	73
3.4.2 Refrigerant charge quantity	74
3.5 Caution in case of refrigerant leakage	78
3.5.1 Maximum permitted concentration of hydrofluorocarbon (HFC)	78
3.5.2 Calculation of refrigerant concentration	78
3.5.3 Countermeasure for refrigerant leakage	78
3.6 Piping work for compatibility with the piping of current installations where is used R22 or R407C.	79
3.6.1 Installation procedure for existing pipes	79
3.6.2 When existing Air-Conditioner is a product of another manufacturer	79
3.6.3 Permissible range for existing Air-Conditioning Pipes (Pipe length in the case of "without cleaning process"	80
3.6.4 Renewal kit selection model	81
3.7 Drain piping	85
3.7.1 Drain discharging boss	85
4. Electrical wiring	87
4.1 General notes	88
4.1.1 General check	88
4.2 Electrical wiring connection for the outdoor unit	90
4.3 Setting the DIP switches for the outdoor unit	92

4.3.1	Quantity and position of DIP switches.....	92
4.3.2	Function of the of DIP switches and RSW switches.....	93
4.3.3	Jumpers.....	97
4.3.4	LED's indication.....	97
4.4	Common wiring.....	98
4.4.1	Electrical wiring between outdoor and indoor unit.....	98
4.4.2	Wire size.....	99
4.5	H-LINK II system.....	101
4.5.1	Features	101
4.5.2	Specifications	101
4.5.3	DIP Switch setting for twin, triple and quad systems.....	102
4.5.4	Examples of the system of connection between H-LINK and H-LINK II units	103
4.5.5	Examples of H-LINK II system	104
4.6	System Control	106
4.6.1	Individual Operation	106
4.6.2	Simultaneous Operation.....	107
4.7	Electrical wiring diagrams	108
4.7.1	RAS-(2-2.5)HVNP / RAS-3HVNC (1~ 230V 50Hz).....	108
4.7.2	RAS-3HVNPE (1~ 230V 50Hz).....	109
4.7.3	RAS-(4-6)HVNPE (1~ 230V 50Hz)	110
4.7.4	RAS-(4-6)HNPE (3N~ 400V 50Hz)	111
4.7.5	RAS-(4-6)HVNCE (1N~ 230V 50Hz).....	112
4.7.6	RAS-(4-6)HNCE (3N~ 400V 50Hz).....	113
4.7.7	RAS-(8-10)HN(P/C)E (3N~ 400V 50Hz)	114
4.7.8	RAS-12HNP (3N~ 400V 50Hz) - Preliminary data	115
4.7.9	RAS-12HNC (3N~ 400V 50Hz) - Preliminary data.....	116
5.	Control System.....	117
5.1	Device control system.....	118
5.2	Outdoor units PCB.....	120
5.2.1	RAS-(2-2.5)HVNP / RAS-3HVNC	120
5.2.2	RAS-3HVNPE	121
5.2.3	RAS-(4-6)H(V)NPE	122
5.2.4	RAS-(4-6)H(V)NCE	123
5.2.5	RAS-(8-10)HN(P/C)E	124
5.2.6	RAS-12HNP - Preliminary data	125
5.2.7	RAS-12HNC - Preliminary data.....	126
5.3	Protection and safety control	127
5.4	Standard operation sequence.....	128

5.4.1 Cooling operation	128
5.4.2 Dry operation.....	130
5.4.3 Heating operation	132
5.4.4 Automatic cooling and heating operation	134
5.4.5 Defrost operation control.....	135
5.5 Standard control functions.....	138
5.5.1 Freezing protection during cooling process or dry operation	138
5.5.2 Prevention Control for High Pressure Increase during Cooling Operation.....	139
5.5.3 Prevention control for excessively high discharge gas temperature	140
5.5.4 Activation for protection device control.....	141
5.5.5 Preheating control of compressor	142
5.5.6 Prevention control for high pressure increase.....	143
6. Optional functions.....	145
6.1 Optional input and output signals (By 7-segment display)	146
6.1.1 Available ports	146
6.1.2 Available optional signals	148
6.1.3 Setting of the optional signals	150
6.1.4 Description of optional signals.....	151
6.2 Optional functions (By 7-segment display)	154
6.2.1 Setting of the optional functions	154
6.2.2 Description of the optional functions	157
6.3 Optional functions (By remote control switch)	161
7. Test run.....	167
7.1 Checking procedure before the test run	168
7.2 Test run procedure using the remote control switch (PC-ART)	170
7.3 Test run procedure using the remote control switch (PC-ARF)	172
7.4 Test run procedure using the wireless remote control switch (PC-LH3A/B)	175
7.5 Test run procedure from the outdoor unit side	177
7.6 Check list	179
7.6.1 Check list on test run.....	179
7.6.2 Check list on compressor.....	180
8. Troubleshooting	183
8.1 Initial troubleshooting.....	184
8.1.1 Checking by means of the 7-segment display.....	184
8.1.2 Failure of the power supply to the indoor unit and the remote control switch	185

8.1.3	Abnormal transmission between the remote control switch and the indoor unit.....	186
8.1.4	Abnormal operation of the devices	186
8.2	Troubleshooting procedure	192
8.2.1	Alarm display	192
8.2.2	Alarm codes for the outdoor and indoor units.....	193
8.2.3	Troubleshooting by alarm code for the outdoor and indoor units	194
8.2.4	Alarm codes for the KPI (E/H/X)3E Series and DX Interface	252
8.3	Troubleshooting in check mode	253
8.3.1	Troubleshooting using the remote controller PC-ART	253
8.3.2	Troubleshooting using the remote controller PC-ARF	263
8.3.3	Troubleshooting using the 7 segment display	268
8.4	Checking procedure for main parts.....	277
8.4.1	Procedure for checking the DIP-IPM inverter for indoor and outdoor units.....	277
8.4.2	Checking capacitors CB1 & CB2.....	283
8.4.3	Fault diagnosis of DC fan motor.....	284
8.4.4	Checking procedure for the electronic expansion valve for indoor and outdoor units.....	285
8.4.5	Checking procedure for AC fan motor	285
8.4.6	Checking procedure for other parts.....	286
9.	Spare parts.....	289
9.1	RAS-(2-2.5)HVNP.....	290
9.1.1	Cycle and structural parts.....	290
9.1.2	Parts table	291
9.2	RAS-3HVNC	292
9.2.1	Cycle and structural parts.....	292
9.2.2	Parts table	293
9.3	RAS-3HVNPE.....	294
9.3.1	Cycle and structural parts.....	294
9.3.2	Electrical parts	295
9.3.3	Parts name	296
9.4	RAS-(4-6)H(V)NPE.....	297
9.4.1	Cycle and structural parts.....	297
9.4.2	Electrical parts	298
9.4.3	Parts name	300
9.5	RAS-(4-6)H(V)NCE.....	302
9.5.1	Cycle and structural parts.....	302
9.5.2	Electrical parts	304
9.5.3	Parts name	306
9.6	RAS-(8-10)HN(P/C)E.....	308

9.6.1 Cycle and structural parts.....	308
9.6.2 Electrical parts.....	310
9.6.3 Parts name.....	311
9.7 RAS-12HN(P/C).....	314
9.7.1 Cycle and structural parts.....	314
9.7.2 Electrical parts.....	315
9.7.3 Parts name.....	316
10. Servicing	319
10.1 Introduction.....	323
10.2 Servicing for Outdoor Units RAS-(2-2.5)HVNP and RAS-3HVNC.....	324
10.2.1 Removing pipe cover.....	324
10.2.2 Removing front cover.....	324
10.2.3 Removing outdoor fan.....	324
10.2.4 Removing the compressor.....	325
10.2.5 Removing high pressure switch and pressure switch for control.....	327
10.2.6 Removing four-way valve coil.....	328
10.2.7 Removing electronic expansion valve coil.....	328
10.2.8 Removing electrical components.....	329
10.3 Servicing for Premium series.....	332
10.3.1 Outdoor unit RAS-3HVNPE.....	332
10.3.1.1 Removing service cover.....	332
10.3.1.2 Remove outlet grille.....	332
10.3.1.3 Removing upper cover.....	333
10.3.1.4 Removing bottom service cover and rear cover.....	333
10.3.1.5 Removing outdoor fan motor.....	334
10.3.1.6 Removing electrical box.....	335
10.3.1.7 Removing the compressor.....	336
10.3.1.8 Removing the High pressure switch and Pressure switch for control.....	339
10.3.1.9 Opening electrical box (P plate).....	340
10.3.1.10 Removing Reversing valve coil.....	340
10.3.1.11 Removing electronic expansion valve coil.....	341
10.3.1.12 Removing solenoid valve coil (SVC).....	341
10.3.1.13 Removing reversing valve.....	342
10.3.1.14 Removing Electronic expansion Valve and Solenoid Valve.....	343
10.3.1.15 Removing electrical components.....	343
10.3.1.16 Removing other electrical components.....	345
10.3.2 Outdoor units RAS-(4-6)H(V)NPE.....	346
10.3.2.1 Removing service cover.....	346
10.3.2.2 Removing air outlet grille.....	346
10.3.2.3 Removing upper cover.....	347
10.3.2.4 Removing the bottom service cover and rear cover.....	347

10.3.2.5	Removing outdoor fan motor	348
10.3.2.6	Removing electrical box	349
10.3.2.7	Removing the compressor	350
10.3.2.8	Removing the High pressure switch and Pressure switch for control	353
10.3.2.9	Opening electrical box (P plate)	354
10.3.2.10	Removing Reversing valve coil	354
10.3.2.11	Removing electronic expansion valve coil	355
10.3.2.12	Removing solenoid valve coil (SVA and SVC)	355
10.3.2.13	Removing reversing valve	356
10.3.2.14	Removing Electronic expansion Valve and Solenoid Valve	357
10.3.2.15	Removing electrical components	358
10.3.2.16	Removing other electrical components	359
10.3.3	Outdoor units RAS-(8-10)HNPE	360
10.3.3.1	Removing service cover	360
10.3.3.2	Removing air outlet grille	360
10.3.3.3	Removing upper cover	361
10.3.3.4	Removing the bottom service cover and rear cover	361
10.3.3.5	Removing outdoor fan motor	362
10.3.3.6	Removing electrical box	363
10.3.3.7	Removing the compressor	364
10.3.3.8	Removing High pressure switch and pressure switch for control	367
10.3.3.9	Opening electrical box (P-Mounting Plate)	367
10.3.3.10	Removing reversing valve coil	368
10.3.3.11	Removing electronic expansion valve coil	369
10.3.3.12	Removing solenoid valve coil (SVA and SVC)	369
10.3.3.13	Removing reversing valve	370
10.3.3.14	Removing Electronic expansion Valve and Solenoid Valve	371
10.3.3.15	Removing electrical components	372
10.3.3.16	Removing other electrical components	374
10.3.4	Outdoor Units RAS-12HNP	375
10.3.4.1	Removing service cover	375
10.3.4.2	Removing air outlet grille	375
10.3.4.3	Removing upper cover	376
10.3.4.4	Removing the bottom service cover and rear cover	376
10.3.4.5	Removing outdoor fan motor	377
10.3.4.6	Removing electrical box	378
10.3.4.7	Removing the compressor	379
10.3.4.8	Removing High pressure switch and pressure switch for control	382
10.3.4.9	Removing reversing and solenoid valves coils	383
10.3.4.10	Removing electronic expansion valve coil	384
10.3.4.11	Removing reversing valve	385
10.3.4.12	Removing Electronic expansion Valve and Solenoid Valve	386
10.3.4.13	Removing electrical components	388

10.3.4.14 Removing other electrical components	390
10.4 Servicing for Standard Series	391
10.4.1 Outdoor Units RAS-(4-6)H(V)NCE	391
10.4.1.1 Removing service cover	391
10.4.1.2 Remove outlet grille.....	391
10.4.1.3 Removing upper cover	392
10.4.1.4 Removing bottom service cover and rear cover.....	392
10.4.1.5 Removing outdoor fan motor.....	393
10.4.1.6 Removing electrical box	394
10.4.1.7 Removing the compressor	395
10.4.1.8 Removing the High pressure switch and Pressure switch for control	401
10.4.1.9 Opening electrical box (P plate)	402
10.4.1.10 Removing Reversing valve coil	402
10.4.1.11 Removing electronic expansion valve coil.....	403
10.4.1.12 Removing solenoid valve coil (SVA).....	403
10.4.1.13 Removing reversing valve	404
10.4.1.14 Removing Electronic expansion valve and Solenoid valve	405
10.4.1.15 Removing electrical components	405
10.4.1.16 Removing other electrical components	407
10.4.2 Outdoor Units RAS-(8-10)HNCE.....	408
10.4.2.1 Removing service cover	408
10.4.2.2 Removing air outlet grille.....	408
10.4.2.3 Removing upper cover	409
10.4.2.4 Removing the bottom service cover and rear cover.....	409
10.4.2.5 Removing outdoor fan motor.....	410
10.4.2.6 Removing electrical box	411
10.4.2.7 Removing the compressor	412
10.4.2.8 Removing High pressure switch and pressure switch for control.....	415
10.4.2.9 Opening electrical box (P-Mounting Plate).....	415
10.4.2.10 Removing reversing valve coil.....	416
10.4.2.11 Removing electronic expansion valve coil.....	417
10.4.2.12 Removing solenoid valve coil (SVA).....	417
10.4.2.13 Removing reversing valve	418
10.4.2.14 Removing Electronic expansion Valve and Solenoid Valve	419
10.4.2.15 Removing electrical components	420
10.4.2.16 Removing other electrical components	422
10.4.3 Outdoor Units RAS-12HNC.....	423
10.4.3.1 Removing service cover	423
10.4.3.2 Removing air outlet grille.....	423
10.4.3.3 Removing upper cover	424
10.4.3.4 Removing the bottom service cover and rear cover.....	424
10.4.3.5 Removing outdoor fan motor.....	425

10.4.3.6 Removing electrical box	426
10.4.3.7 Removing High pressure switch and pressure switch for control.....	430
10.4.3.8 Opening electrical box (P-Mounting Plate).....	430
10.4.3.9 Removing reversing and solenoid valves coils.....	431
10.4.3.10 Removing electronic expansion valve coil.....	432
10.4.3.11 Removing reversing valve	433
10.4.3.12 Removing Electronic expansion Valve and Solenoid Valve	434
10.4.3.13 Removing electrical components	435
10.4.3.14 Removing other electrical components	437
11. Electrical checks of main parts	439
11.1 Inverter.....	440
11.1.1 Specifications of inverter	440
11.1.2 Inverter time chart.....	442
11.1.3 Protective function	443
11.1.4 Overload control	444
11.2 Thermistor.....	445
11.3 Electronic expansion valve	447
11.4 High pressure protection device	448
11.5 Noise filter (NF).....	450
11.5.1 Noise filter for 3N~ (400V/50Hz).....	450
11.5.2 Noise filter for 1~ (230V/50Hz)	451
11.6 Capacitor (CB1 CB2)	452
11.7 Reactor (DCL).....	453
11.7.1 Reactor (DCL) for 3N~ (400V/50Hz)	453
11.7.2 Reactor (DCL) for 1~ (230V/50Hz).....	453
11.8 Scroll compressor	454
11.8.1 Reliable mechanism for low vibrating and low sound.....	454
11.8.2 Principle of compression	454
12. Maintenance notes	455
12.1 General notes	456
12.1.1 Checking the power source and the wiring connection	456
12.1.2 Burnt-out compressor due to an insufficient refrigerant charge	456
12.1.3 Insufficient cooling performance when a long piping is applied	457
12.1.4 Abnormally high operation sound (in the ceiling type indoor unit).....	457
12.1.5 Alarm code “31”	458
12.1.6 Not cooling well due to insufficient installation space for the outdoor unit	458
12.2 Maintenance work.....	459

12.3 Service and maintenance record 460

12.4 Service and maintenance record using the 7-segment display 461

12.5 Service and maintenance record by remote control switch 463

12.6 Pump-down method for replacing the compressor 464

1 . General information

Index

- 1.1. General information..... 2
 - 1.1.1. General notes..... 2
 - 1.1.2. Introduction..... 2
 - 1.1.3. Environment-friendly units..... 2
- 1.2. Safety..... 3
 - 1.2.1. Applied symbols..... 3
 - 1.2.2. Norms and Regulations..... 3
- 1.3. Product guide..... 4
 - 1.3.1. Classification of outdoor unit models..... 4
 - 1.3.2. Classification of indoor unit models..... 4
 - 1.3.3. Product guide: Outdoor units..... 5
 - 1.3.4. Outdoor unit accessory code list..... 6
 - 1.3.5. Product guide: Indoor units & complementary systems..... 7
 - 1.3.6. Product guide: complementary systems..... 10

1.1 General information

1.1.1 General notes

No part of this publication may be reproduced, copied, filed or transmitted in any shape or form without the permission of HITACHI Air Conditioning Products Europe, S.A.

Within the policy of continuous improvement of its products, HITACHI Air Conditioning Products Europe, S.A. reserves the right to make changes at any time without prior notification and without being compelled to introducing them into products subsequently sold. This document may therefore have been subject to amendments during the life of the product.

HITACHI makes every effort to offer correct, up-to-date documentation. Despite this, printing errors cannot be controlled by HITACHI and are not its responsibility.

As a result, some of the images or data used to illustrate this document may not refer to specific models. No claims will be accepted based on the data, illustrations and descriptions included in this manual.

No type of modification must be made to the equipment without prior, written authorisation from the manufacturer.

HITACHI pursues a policy of continuing improvement in design and performance of Products. The right is therefore reserved to vary specifications without notice.

HITACHI cannot anticipate every possible circumstance that might involve a potential hazard.

No part of this manual may be reproduced without written permission.

1.1.2 Introduction

Hitachi UTOPIA series is an outdoor unit series designed with the goal to cover the requirements of the split and multisplit systems, for installations where from one indoor unit (single system) to up to 8 indoor units, are connected to the same IVX Premium outdoor unit (depending on model).

New UTOPIA series consists in two different outdoor unit series: IVX Premium and IVX Standard, which compliant with the Seasonal Efficiency driven by the EU's Energy Product Directive (Eco Design Directive (EuP Lot 10)) and Seasonal Efficiency design concept in order to meet the European Directive on seasonal efficiency (Lot 6/21 coming in 2015) (depending on the model). The Seasonal Energy Efficiency Ratio (SEER) in cooling and the Seasonal Coefficient of Performance (SCOP) in heating, show an approach values to the real energy consumption.

UTOPIA series incorporate the Hitachi inverter technology, which makes possible to adapt automatically and without the user operation the capacity of the unit, so the power input, to the real demand of the installation, increasing the system efficiency to unattainable levels with other technologies. All UTOPIA units are equipped with a heat pump, resulting in an air conditioning system valid for the whole year, in which the installation of additional and specific systems a not necessary.

IVX Premium

Nominal capacity from 5 kW to 30 kW (cooling mode). Connectable indoor units up to 8 units (depending on model) and total combination power from 50% up to 120%, outdoor units from 3 to 12HP, or 90% up to 110% for 2 and 2.5 HP outdoor units.

IVX Standard

Nominal capacity from 7.1 kW to 30 kW (cooling mode). Connectable indoor units up to 4 units (3 units for 3HP model) and total combination power from 90% up to 115%, outdoor units from 4 to 12HP, or 90% up to 110% for 3HP outdoor units.

Indoor Units

One of the main merits of Hitachi units range is the combinability and flexibility of its indoor units SYSTEM FREE. This outstanding technology makes possible to use the same indoor units with both UTOPIA and SET FREE outdoor units, making easier the design, installation and control of the air conditioning installations.

1.1.3 Environment-friendly units

This range of HITACHI outdoor units uses environmentally-friendly R410A gas refrigerant, and the RoHS and Green Dot regulations are applied throughout the manufacturing and installation process to reflect HITACHI's awareness of environmental respect and commitment.

R410A is totally environmentally-friendly since it does not contain any substances that damage the ozone layer:

ODP (ozone depleting product) =0.

HITACHI's UTOPIA series are very efficient and allow significant energy savings compared with conventional systems.

This energy efficiency means less production of CO₂, which causes the greenhouse effect.



1.2 Safety

1.2.1 Applied symbols

During normal air conditioning system design work or unit installation, greater attention must be paid in certain situations requiring particular care in order to avoid damage to the unit, the installation or the building or property.

Situations that jeopardise the safety of those in the surrounding area or that put the unit itself at risk will be clearly indicated in this manual.

To indicate these situations, a series of special symbols will be used to clearly identify these situations.

Pay close attention to these symbols and to the messages following them, as your safety and that of others depends on it.

DANGER

- ***The text following this symbol contains information and instructions relating directly to your safety and physical wellbeing.***
- ***Not taking these instructions into account could lead to serious, very serious or even fatal injuries to you and others in the proximities of the unit.***

In the texts following the danger symbol you can also find information on safe procedures during unit installation.

CAUTION

- ***The text following this symbol contains information and instructions relating directly to your safety and physical wellbeing.***
- ***Not taking these instructions into account could lead to minor injuries to you and others in the proximities of the unit.***
- ***Not taking these instructions into account could lead to unit damage.***

In the texts following the caution symbol you can also find information on safe procedures during unit installation.

NOTE

- ***The text following this symbol contains information or instructions that may be of use or that require a more thorough explanation.***
- ***Instructions regarding inspections to be made on unit parts or systems may also be included.***

1.2.2 Norms and Regulations

Following Regulation EC N° 842/2006 on Certain Fluorinated Greenhouse gases, the total amount of refrigerant charged in the unit is indicated on the specification label.

Do not vent R410A/R407C into the atmosphere. R410A & R407C are fluorinated greenhouse gases covered by the Kyoto protocol global warming potential (GWP) R410A/R407C: = 1975/1652.5.

1.3 Product guide

1.3.1 Classification of outdoor unit models

◆ IVX series

Unit type (Outdoor unit): RAS

Position-separating hyphen (fixed)									
Capacity (HP): 2, 2.5, 3, 4, 5, 6, 8, 10, 12									
H = Heat pump									
V = Single phase unit (1~ 230V 50Hz)									
- = Three phase unit (3N~ 400V 50Hz)									
N = R410A refrigerant									
P: Premium series									
C: Standard series									
E = Made in Europe									
- = Made in Japan									
XXX	-	XX	H	(X)	N	X	(X)		





1.3.2 Classification of indoor unit models

Unit type (indoor unit): RCI, RCIM, RCD, RPC, RPI, RPIM, RPK, RPF, RPF1





Position-separating hyphen (fixed)									
Capacity (HP): 0.8, 1.0, 1.5, 2.0, 2.5, 3.0, 4.0, 5.0, 6.0, 8.0, 10.0									
FS = SYSTEM FREE									
N = R410A refrigerant									
H = Hotel (RPK-(0.8/1.5) only)									
2/3/4 = series									
E = Made in Europe									
M = Made in Malaysia									
- = Made in Japan									
i = Version up									
DU = Drain Up (RPIM only)									
XXX	-	X.X	FS	N	(H)	(X)	(X)	i	(-DU)

1.3.3 Product guide: Outdoor units

◆ IVX Premium

❄️ 🔥									
1~ 230V 50Hz					3N~ 400V 50Hz				
									
Unit	Code	Unit	Code	Unit	Code	Unit	Code	Unit	Code
RAS-2HVNP	60288519								
RAS-2.5HVNP	60288520								
		RAS-3HVNP	7E304005						
				RAS-4HVNP	7E304007	RAS-4HNPE	7E304107		
				RAS-5HVNP	7E304008	RAS-5HNPE	7E304108		
				RAS-6HVNP	7E304009	RAS-6HNPE	7E304109		
						RAS-8HNPE	7E310110		
						RAS-10HNPE	7E310111		
								RAS-12HNP	60278974

◆ IVX Standard

❄️ 🔥									
1~ 230V 50Hz					3N~ 400V 50Hz				
									
Unit	Code	Unit	Code	Unit	Code	Unit	Code	Unit	Code
RAS-3HVNC	60288523								
		RAS-4HVNCE	7E305027	RAS-4HNCE	7E305127				
		RAS-5HVNCE	7E305028	RAS-5HNCE	7E305128				
		RAS-6HVNCE	7E305029	RAS-6HNCE	7E305129				
						RAS-8HNCE	7E311110		
						RAS-10HNCE	7E311111		
								RAS-12HNC	60288572

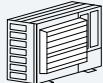
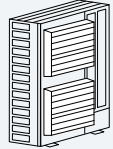
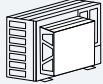
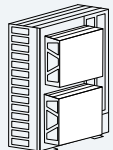
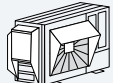

1.3.4 Outdoor unit accessory code list

Name	Description	Code	Figure
DBS-26	Drain discharge connection	60299192	
AG-264	Air flow guide	-	
AG-335A	Air flow guide	60291431	
WSP-264	Wind guard	60291728	
WSP-335A	Wind guard	60291432	
ASG-NP80F	Snow protection hood; air outlet (Zinc plate)	-	
ASG-NP80FS2	Snow protection hood; air outlet (Stainless plate)	-	
ASG-NP335F	Snow protection hood; air outlet (Zinc plate)	60291433	
ASG-NP335FS2	Snow protection hood; air outlet (Stainless plate)	-	
ASG-NP56B	Snow protection hood; air inlet of rear side (Zinc plate)	-	
ASG-NP63BS2	Snow protection hood; air inlet of rear side (Stainless plate)	-	
ASG-NP80B	Snow protection hood; air inlet of rear side (Zinc plate)	-	
ASG-NP160BS2	Snow protection hood; air inlet of rear side (Stainless plate)	-	
ASG-NP280B	Snow protection hood; air inlet of rear side (Zinc plate)	-	
ASG-NP280BS2	Snow protection hood; air inlet of rear side (Stainless plate)	-	
ASG-NP335B	Snow protection hood; air inlet of rear side (Zinc plate)	60291434	
ASG-NP335BS2	Snow protection hood; air inlet of rear side (Stainless plate)	-	
ASG-NP56L	Snow protection hood; air inlet of left side (Zinc plate)	-	
ASG-NP63LS2	Snow protection hood; air inlet of left side (Stainless plate)	-	
ASG-NP80L	Snow protection hood; air inlet of left side (Zinc plate)	-	
ASG-NP160LS2	Snow protection hood; air inlet of left side (Stainless plate)	-	
ASG-NP280L	Snow protection hood; air inlet of left side (Zinc plate)	-	
ASG-NP280LS2	Snow protection hood; air inlet of left side (Stainless plate)	-	
ASG-NP335L	Snow protection hood; air inlet of left side (Zinc plate)	60291435	
ASG-NP335LS2	Snow protection hood; air inlet of left side (Stainless plate)	-	





NOTE

HITACHI has a range of accessories and remote control systems that can be used with the UTOPIA outdoor units. Please, refer to the Controls Technical Catalogue.

1.3.5 Product guide: Indoor units & complementary systems

◆ RCI and RCIM indoor units

FSN(2/3)(E)(i) indoor units					
RCI			RCIM		
					
4-way cassette				4-way cassette (compact)	
Unit	Code	Unit	Code	Unit	Code
RCI-1.0FSN3Ei	7E403014	RCI-1.0FSN3	60278119	RCIM-0.8FSN2	60278010
RCI-1.5FSN3Ei	7E403015	RCI-1.5FSN3	60278120	RCIM-1.0FSN2	60278011
RCI-2.0FSN3Ei	7E403016	RCI-2.0FSN3	60278121	RCIM-1.5FSN2	60278013
RCI-2.5FSN3Ei	7E403017	RCI-2.5FSN3	60278122	RCIM-2.0FSN2 (*)	60278014
RCI-3.0FSN3Ei	7E403018	RCI-3.0FSN3	60278123		
RCI-4.0FSN3Ei	7E403020	RCI-4.0FSN3	60278124		
RCI-5.0FSN3Ei	7E403021	RCI-5.0FSN3	60278125		
RCI-6.0FSN3Ei	7E403022	RCI-6.0FSN3	60278126		

Panels (Optional)					
					
P-N23NA	70531000	P-AP160NA1	60297215	P-N23WAM	60197160
		P-AP160NAE (With motion sensor)	60297217		



NOTE

- The RCI and RCIM models must be used in combination with the panels indicated above.
- (*): Single combinations with IVX Premium/Standard series not allowed

◆ **RCD and RPC indoor units**

FSN2(E) indoor units					
RCD			RPC		
					
2-way cassette			Ceiling type		
Unit	Code			Unit	Code
RCD-1.0FSN2	60278029				
RCD-1.5FSN2	60278030				
RCD-2.0FSN2	60278031			RPC-2.0FSN2E	7E440003
RCD-2.5FSN2	60278032			RPC-2.5FSN2E	7E440004
RCD-3.0FSN2	60278033			RPC-3.0FSN2E	7E440005
		RCD-4.0FSN2	60278034	RPC-4.0FSN2E	7E440007
		RCD-5.0FSN2	60278035	RPC-5.0FSN2E	7E440008
				RPC-6.0FSN2E	7E440009

Panels (Optional)			
			
P-N23DNA	60297211	P-N46DNA	60297212



NOTE



- *The RCD models must be used in combination with the panels indicated above.*

◆ **RPC, RPI and RPIM indoor units**

FSN(3/4)E indoor units					
RPI			RPIM		
					
Indoor ducted unit					
Unit	Code	Unit	Code	Unit	Code
RPI-0.8FSN4E	7E424013			RPIM-0.8FSN4E	7E430013
				RPIM-0.8FSN4E-DU	7E431013
RPI-1.0FSN4E	7E424014			RPIM-1.0FSN4E	7E430014
				RPIM-1.0FSN4E-DU	7E431014
RPI-1.5FSN4E	7E424015			RPIM-1.5FSN4E	7E430015
				RPIM-1.5FSN4E-DU	7E431015
RPI-2.0FSN4E	7E424016				
RPI-2.5FSN4E	7E424017				
RPI-3.0FSN4E	7E424018				
RPI-4.0FSN4E	7E424020				
RPI-5.0FSN4E	7E424021				
RPI-6.0FSN4E	7E424022				
		RPI-8.0FSN3E	7E424010		
		RPI-10.0FSN3E	7E424011		



◆ RPK, RPF and RPFI indoor units

FSN(H)(2/3)(E/M) indoor units					
RPK		RPF		RPFI	
					
Wall type		Floor type		Floor concealed type	
Unit	Code	Unit	Code	Unit	Code
RPK-0.8FSN3M	60278146				
RPK-0.8FSNH3M	60278154				
RPK-1.0FSN3M	60278147	RPF-1.0FSN2E	7E450001	RPFI-1.0FSN2E	7E460001
RPK-1.0FSNH3M	60278155				
RPK-1.5FSN3M	60278148	RPF-1.5FSN2E	7E450002	RPFI-1.5FSN2E	7E460002
RPK-1.5FSNH3M	60278156				
RPK-2.0FSN3M	60278149	RPF-2.0FSN2E (*)	7E450003	RPFI-2.0FSN2E	7E460003
RPK-2.5FSN3M	60278150	RPF-2.5FSN2E (*)	7E450004	RPFI-2.5FSN2E	7E460004
RPK-3.0FSN3M	60278151				
RPK-4.0FSN3M	60278152				
EV-1.5N1 ⁽¹⁾	60291791				



NOTE

- (*) **Single combinations with IVX Premium/Standard series not allowed**
- (1) **For RPK-(0.8-1.5)FSNH3M models only.**

1.3.6 Product guide: complementary systems
◆ KPI energy / heat recovery unit

Complementary systems					
KPI					
					
Energy recovery		Heat recovery		Active (Energy Recovery+DX section)	
Unit	Code	Unit	Code	Unit	Code
KPI-252E3E	70602000				
KPI-502E3E	70602001	KPI-502H3E	70602101	KPI-502X3E	70602201
KPI-802E3E	70602002	KPI-802H3E	70602102	KPI-802X3E	70602202
KPI-1002E3E	70602003	KPI-1002H3E	70602103	KPI-1002X3E	70602203
KPI-1502E3E	70602004	KPI-1502H3E	70602104		
KPI-2002E3E	70602005	KPI-2002H3E	70602105		

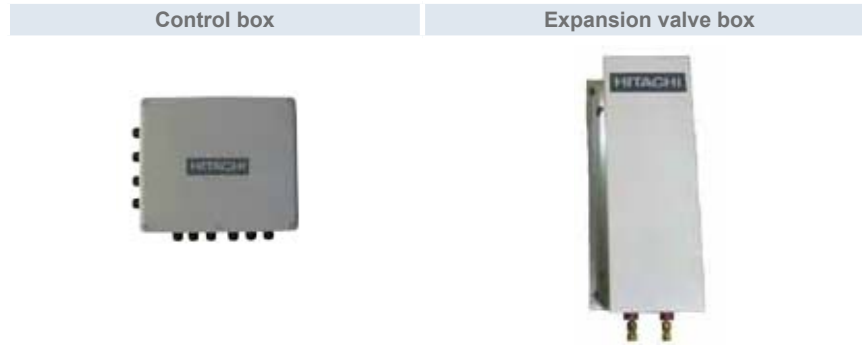
◆ **DX-Interface**



DX-Interface	
Model	Code
EXV-2.0E1	7E610900
EXV-2.5E1	7E610901
EXV-3.0E1	7E610902
EXV-4.0E1	7E610903
EXV-5.0E1	7E610904
EXV-6.0E1	7E610905
EXV-8.0E1	7E610906
EXV-10.0E1	7E610907



2 . Unit Installation

Index

2.1.	Safety summary	14
2.2.	Transportation of outdoor unit	15
2.3.	Center of gravity	16
2.4.	Factory-supplied accessories for RAS-12HN(P/C)	17
2.5.	Installation space (Initial ckeck).....	18
2.5.1.	Basic sizes.....	18
2.5.2.	RAS-(2-2.5)HVNP / RAS-3HVNC.....	19
2.5.3.	RAS-3HVNPE / RAS-(4-6)H(V)N(P/C)E / RAS-(8-10)HN(P/C)E / RAS-12HN(P/C)	20
2.6.	Place provision	23
2.6.1.	Place provision for RAS-(2-2.5)HVNP / RAS-3HVNC	23
2.6.2.	Place provision for RAS-3HVNPE / RAS-(4-6)H(V)N(P/C)E / RAS-(8-10)HN(P/C)E / RAS-12HN(P/C).....	25
2.7.	Optional parts and installation	29
2.7.1.	Optional parts and installation for RAS-(2-2.5)HVNP / RAS-3HVNC	29
2.7.2.	Optional parts and installation RAS-3HVNPE / RAS-(4-6)H(V)NCE	34
2.7.3.	Optional parts and installation RAS-(4-6)H(V)NPE / RAS-(8-10)HN(P/C)E	39
2.7.4.	Optional parts and installation RAS-12HN(P/C).....	45

2.1 Safety summary



DANGER

- *Install the outdoor unit with sufficient clearance around it for operation and maintenance as shown in the next pages.*
- *Install the outdoor unit where good ventilation is available.*
- *Do not install the outdoor unit where exists a high level of oil mist, salty air or sulphurous atmosphere.*
- *Install the outdoor unit as far as practical (being at least 3 meters) from electromagnetic wave radiator such as medical equipment.*
- *Keep clearance between units of more than 50 mm and avoid obstacles that could hamper air intake when installing more than one unit together.*
- *Install the outdoor unit in the shade or not exposed to direct sunshine or direct radiation from high temperature heat source.*
- *Do not install the outdoor unit in a place where a seasonal wind directly blows into the outdoor fan.*
- *For cleaning use non-inflammable and nontoxic cleaning liquid. Use of inflammable agent may cause explosion or fire.*
- *Work with sufficient ventilation. Working in an enclosed space could cause oxygen deficiency. Toxic gas may be produced when cleaning agent is heated to high temperature by e.g. being exposed to fire.*
- *Cleaning liquid shall be collected after cleaning.*
- *Pay attention to do not clamp cables when attaching the service cover to avoid electric shock or fire.*



CAUTION

- *Check the foundation to be flat leveled and strongly enough.*
- *Install the unit in a restricted area not accessible by the general public.*
- *Aluminium fins have very sharp edges. Pay attention to the fins in order to avoid injury.*
- *Do not install the indoor units in a flammable environment to avoid a fire or an explosion.*
- *Check to ensure that the ceiling slab is strong enough. If not strong enough the indoor unit may fall down on you.*
- *Do not install the indoor units outdoor unit remote control switch and cable within approximately 3 meters from strong electromagnetic wave radiators such as medical equipment.*
- *Do not install the indoor units in a machinery shop or kitchen where vapour from oil or mist flows to the indoor units. The oil will deposit on the heat exchanger thereby reducing the indoor unit performance and may deform. In the worst case the oil damages the plastic parts of the indoor unit.*
- *To avoid any corrosive action to the heat exchangers do not install the indoor units in an acid or alkaline environment.*
- *When lifting or moving the indoor unit use appropriate slings to avoid damage and be careful not to damage the insulation material on units surface.*
- *This appliance must be used only by adult and capable people having received the technical information or instructions to handle properly and safely this appliance.*
- *Turn OFF all power switches before maintenance is performed.*
- *Do not start the cleaning procedures before 5 minutes of the stop of the unit.*



DANGER

- *Avoid obstacles which may hamper the air intake or the air discharge flow.*
- *Children must be supervised to ensure that they do not play with the electrical appliances.*
- *Before obtaining access to terminals all supply circuits must be disconnected.*

2.2 Transportation of outdoor unit



DANGER

Do not put any foreign material into the outdoor unit and check to ensure that none exists in the outdoor unit before the installation and test run. Otherwise a fire or failure will occur.



CAUTION

Transport the products as close to the installation location as practical before unpacking.

Hanging Method

When hanging the unit ensure the balance of the unit check safety and lift it up smoothly. Do not remove any packing materials and hang the unit under packing condition with two ropes as shown below.

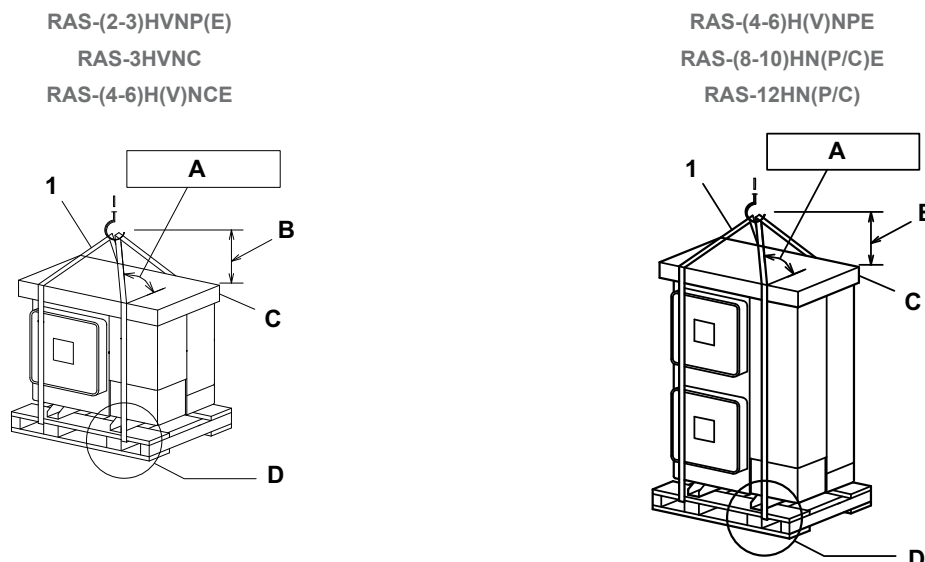

1. Wire rope.
- A. Over 60°.
- B. 0.7 to 1.0 m.
- C. Do not remove the plastic band or the corrugate paper frame.
- D. Pass the wire ropes through each lifting hole in the wooden base as shown.



CAUTION

- Lift the outdoor unit in its factory packaging with 2 wire ropes.
- For safety reasons ensure that the outdoor unit is lifted smoothly and does not lean.
- Do not attach lifting equipment to the plastic band or the corrugated paper frame because of the ropes will slip or break the materials.
- Ensure that the exterior of the unit is adequately protected with cloth or paper.

Gross weight



Premium series	
Model	Weight (kg)
RAS-(2-2.5)HVNP	46
RAS-3HVNP	77
RAS-(4-6)H(V)NPE	116
RAS-8HNPE	149
RAS-10HNPE	151
RAS-12HNP	174

Standard series	
Model	Weight (kg)
RAS-3HVNC	49
RAS-4H(V)NCE	78
RAS-(5-6)H(V)NCE	90
RAS-8HNCE	149
RAS-10HNCE	151
RAS-12HNC	174

2.3 Center of gravity

Hanging Method

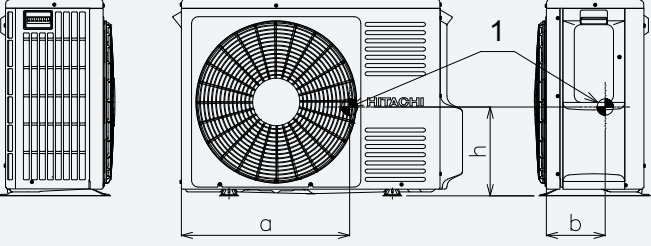
When hanging the unit ensure the balance of the unit check safety and lift it up smoothly. Do not remove any packing materials and hang the unit under packing condition with two ropes as shown below. At least two persons are needed to move the unit.

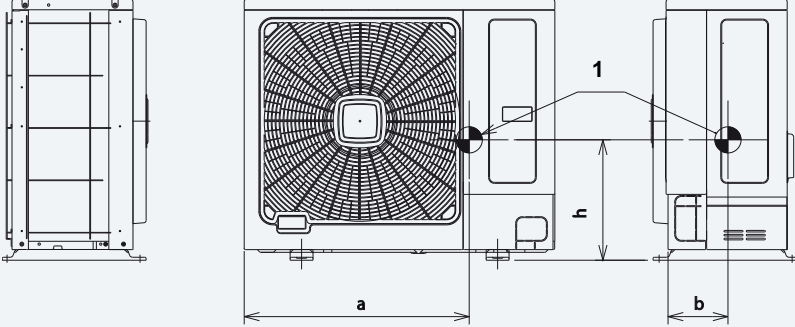
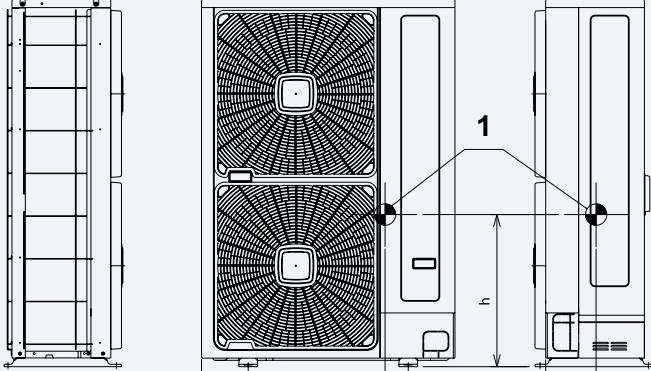
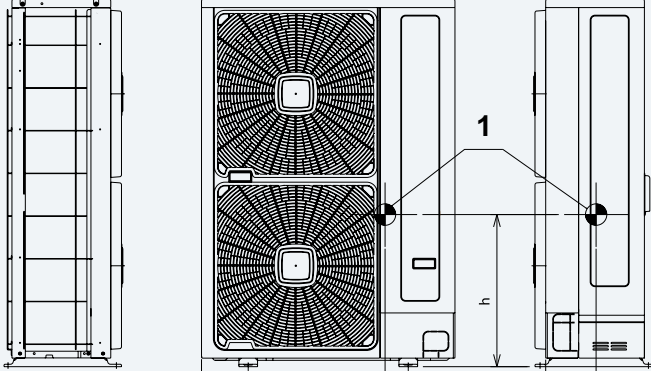
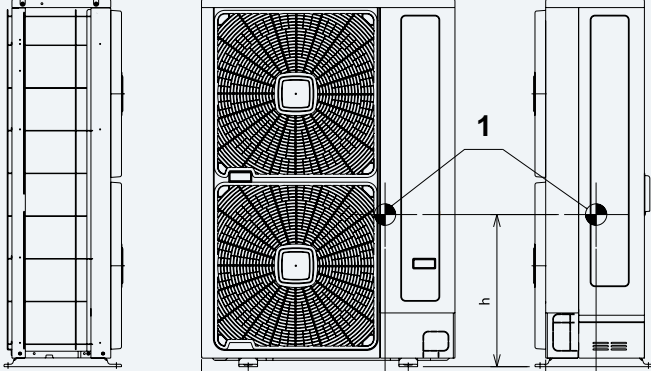
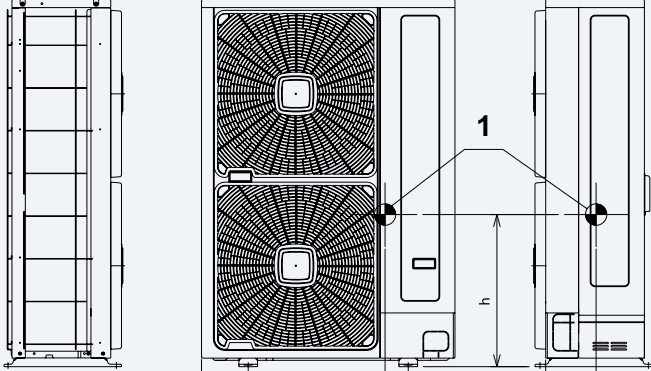
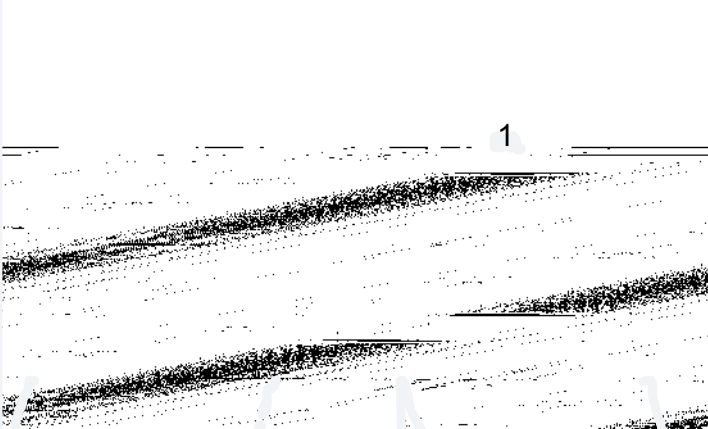
RAS-(2-2.5)HVNP RAS-3HVNC	a. 515 mm b. 180 mm h. 275 mm	
RAS-3HVNPE	a. 600 mm b. 195 mm h. 370 mm	
RAS-(4-6)H(V)NCE	For 4 HP: a. 590 mm b. 180 mm h. 360 mm For 5-6 HP: a. 600 mm b. 195 mm h. 370 mm	
RAS-(4-6)H(V)NPE	a. 613 mm b. 190 mm h. 590 mm	
RAS-8HNPE	a. 610 mm b. 195 mm h. 570 mm	
RAS-8HNCE	a. 615 mm b. 190 mm h. 560 mm	
RAS-10HNPE RAS-10HNCE	a. 610 mm b. 195 mm h. 565 mm	
RAS-12HNP RAS-12HNC	a. 660 mm b. 200 mm h. 680 mm	

1 Center of gravity

2.4 Factory-supplied accessories for RAS-12HN(P/C)

Make sure that the following accessories are packed with the unit.



NOTE

If any of these accessories are not packed with the unit please contact your dealer.

Accessory	Quantity
Pipe with Flare Nut for Refrigerant Piping	1

2

2.5 Installation space (Initial ckeck)



NOTE

The following images are for illustration purposes only.

2.5.1 Basic sizes

◆ RAS-2HVNP - RAS-2.5HVNP - RAS-3HVNC

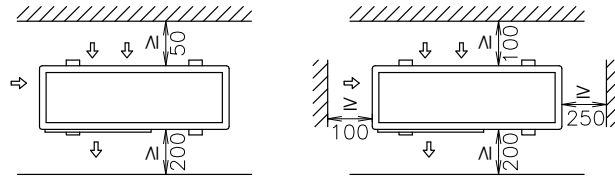

◆ All models (except RAS-2HVNP - RAS-2.5HVNP - RAS-3HVNC)

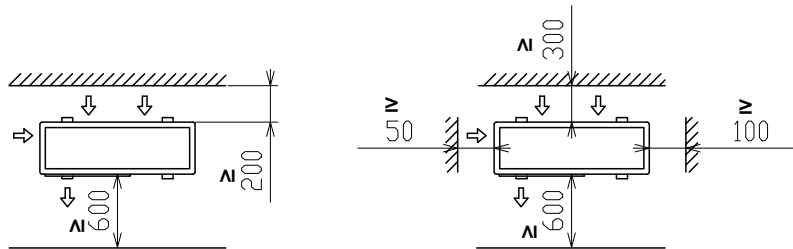

Units in mm.

2.5.2 RAS-(2-2.5)HVNP / RAS-3HVNC

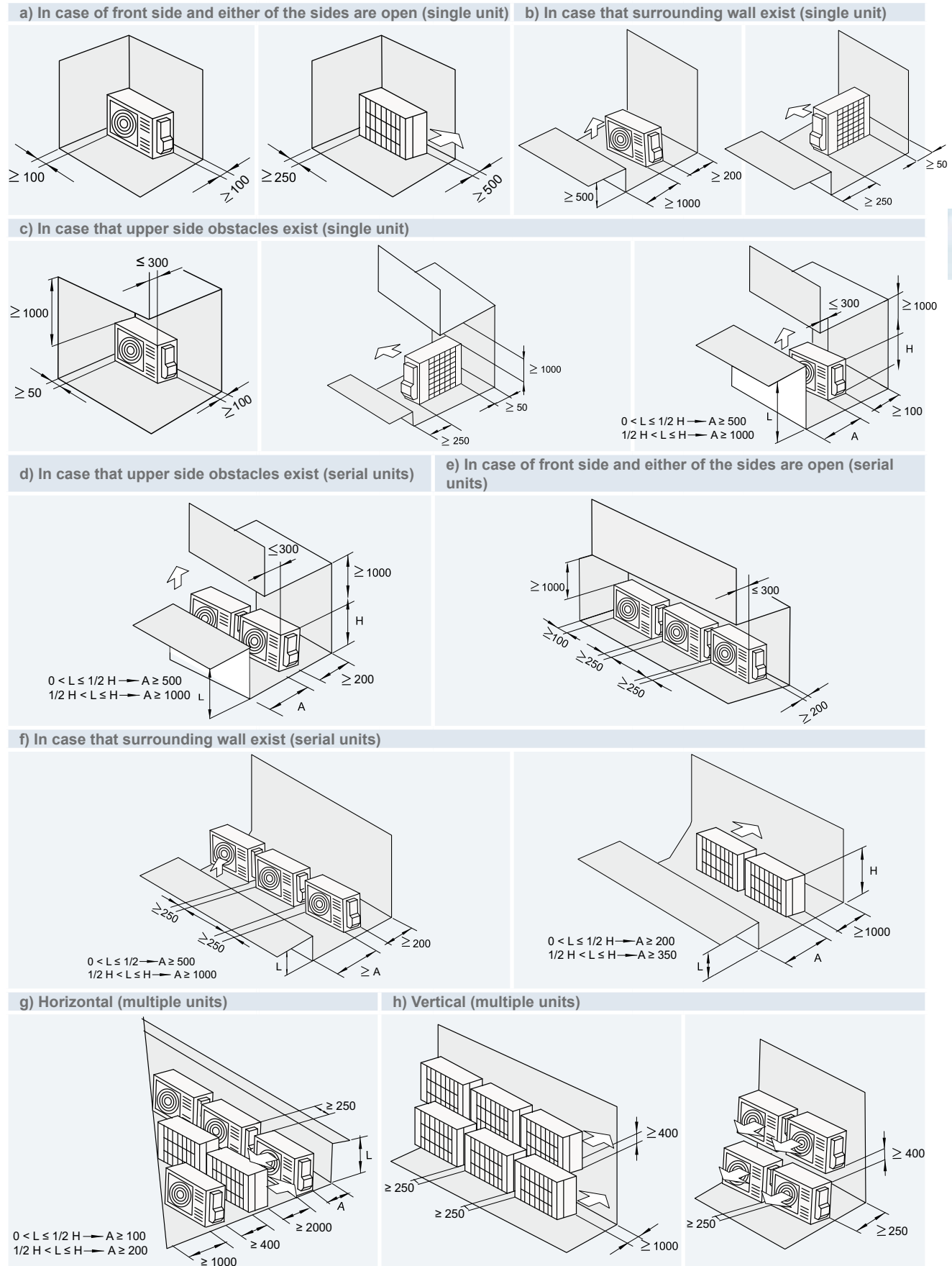

2

- Do not stack more than two units in height.
- Close gap (*) to avoid recirculating discharge air flow.

2.5.3 RAS-3HVNPE / RAS-(4-6)H(V)N(P/C)E / RAS-(8-10)HN(P/C)E / RAS-12HN(P/C)

(Unit: mm)

Blocked in Inlet Side

Upper Side Open

Single Installation

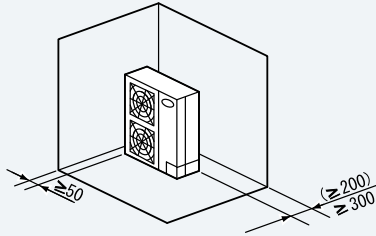

200 or more of the back space is acceptable when the right and left sides are open.
Dimensions in () shows numbers especially for RAS-3HVNPE.

Multiple Installation (Two units or more)

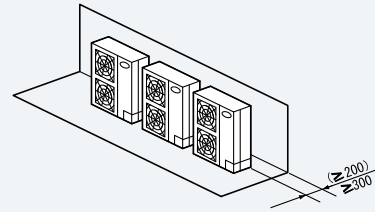

Allow 100 mm of space between units. Leave open both right and left sides.
Dimensions in () shows numbers especially for RAS-3HVNPE.

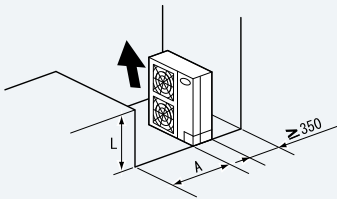

Be sure to use the fan direction guide. Leave open both right and left sides.

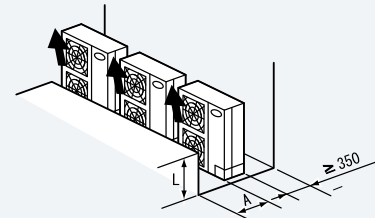

Be sure to use the fan direction guide. Allow 100 mm of space between units. Leave open both right and left sides.

Upper Side Blocked

Single Installation

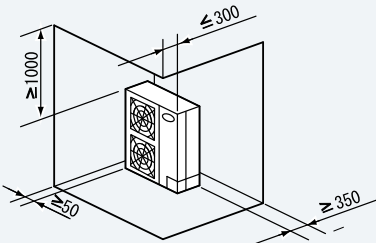

100 mm or more of the side space is acceptable on the service cover side.

Multiple Installation (Two units or more)

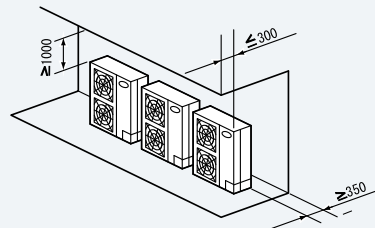

Allow 100 mm of space between units. Leave open both right and left sides..

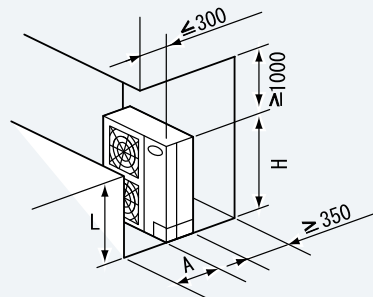

Leave open both right and left sides.

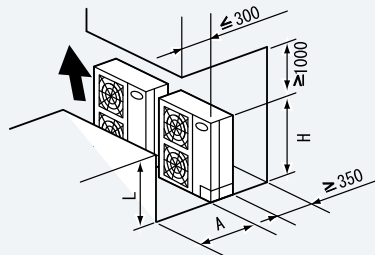

Be sure to use the fan direction guide. Allow 100 mm of space between units. Leave open both right and left sides.
No more than 2 units for multiple installation.

The length A is as shown in the following table:

L	A
$0 < L \leq 1/2H$	600 or greater
$1/2H < L \leq H$	1400 or greater

When $L > H$ use a base for outdoor unit to make $L \leq H$.
Close the base not to allow the outlet air bypassed.

Outlet Side Blocked

Upper Side Open

Single Installation

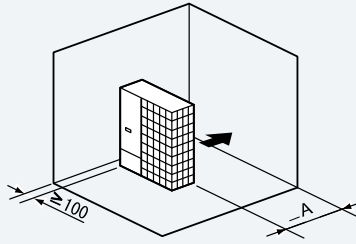

Multiple Installation (Two units or more)

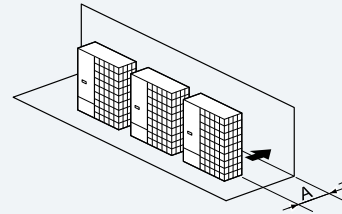

Allow 100 mm of space between units. Both right and left sides shall be open.

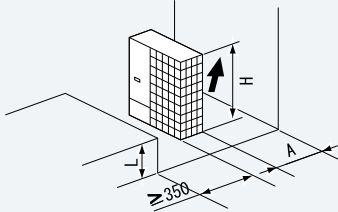

Be sure to use the fan direction guide. Leave open both right and left sides.

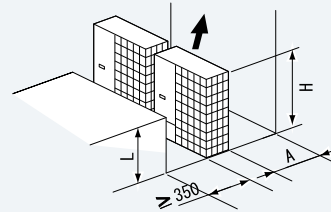

Be sure to use the fan direction guide. Allow 100 mm of space between units. Leave open both right and left sides. No more than 2 units for multiple installation.

The length A is as shown in the following table:

L	A
$0 < L \leq 1/2H$	600 or greater
$1/2H < L \leq H$	1400 or greater

When $L > H$ use a base for outdoor unit to make $L \leq H$. Close the base not to allow the outlet air bypassed.

Lateral Side Blocked

Upper Side Open

Single Installation

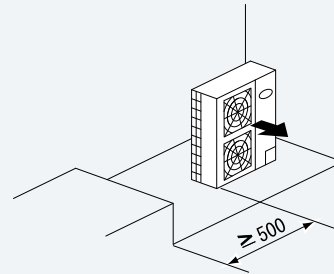
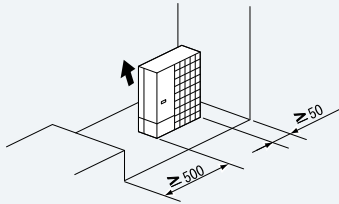

Upper Side Blocked

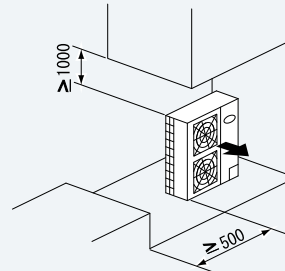
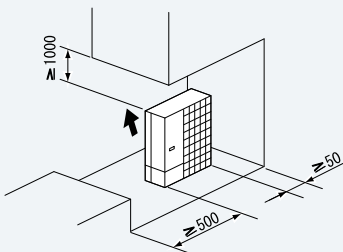

Stack installation (allowed up to 2 Units)

Upper Side Open

Single Installation

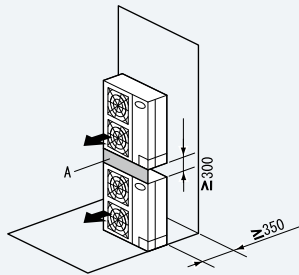

Close the part A not to allow the outlet air bypassed. Install to avoid the drain water from upper unit falling on the lower unit.

Multiple Installation

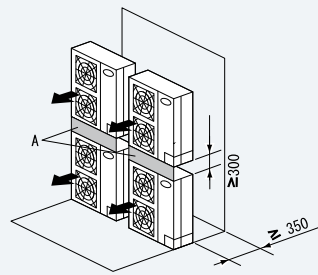

Allow 100 mm of space between units. Serial sideways installation allowed up to two units. Leave open both right and left sides. Close the part A not to allow the outlet air bypassed. Install to avoid the drain water from upper unit falling on the lower unit.

Upper Side Blocked

Single Installation

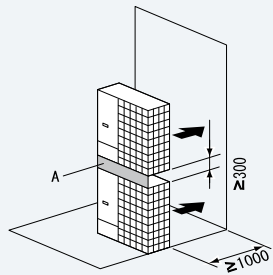

Be sure to use the fan direction guide. Close the part A not to allow the outlet air bypassed. Install to avoid the drain water from upper unit falling on the lower unit.

Multiple Installation

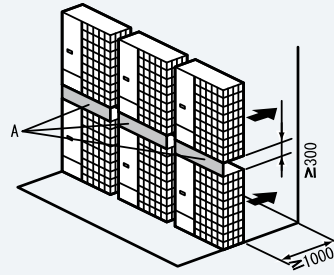

Be sure to use the fan direction guide. Allow 100 mm of space between units. Serial side way installation allowed. but leave open both right and left sides. Close the part A not to allow the outlet air bypassed. Install to avoid the drain water from upper unit falling on the lower unit.

Multiple Installation in Multiple Rows

Serial Installation in Multiple Rows (E.g. Rooftop)

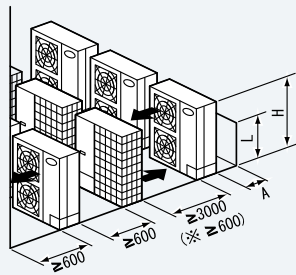

Allow approx. 100 mm of space from the side unit. Leave open both right and left sides.

The length A is as shown in the following table:

L	A
$0 < L \leq 1/2H$	≤ 300
$1/2H < L \leq H$	≤ 350



NOTE

When $L > H$ use a base for outdoor unit to make $L = H$. Close the base not to allow the outlet air bypassed. Be sure to use the fan direction guide in order to ensure the length marked with ※.

2.6 Place provision

2.6.1 Place provision for RAS-(2-2.5)HVNP / RAS-3HVNC

1 Secure the outdoor unit with the anchor

1. Base of outdoor unit
2. Nut
3. Special washer (M12)
4. Anchor bolts
5. Filled mortar
6. Concrete
- A. Max. 17 mm

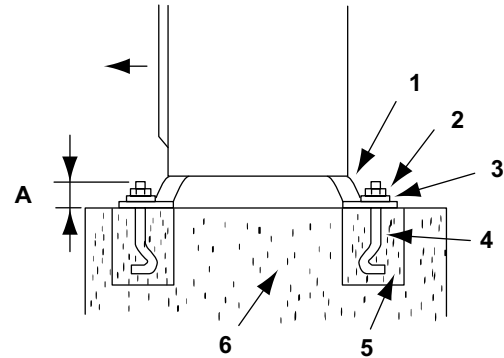

2

Fix the outdoor unit to the anchor bolts by special washer of factory-supplied accessory.

2 When installing the outdoor unit fix the unit by anchor bolts.Regarding the location of fixing holes.

1. M10 Hole for anchor bolt (Ø12)
2. Pipe cover
3. Front side

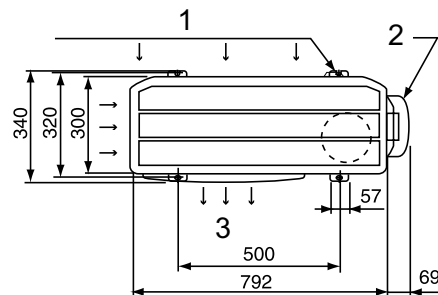

Example of fixing outdoor unit by anchor bolts.

1. Max. 17 mm (After cut "A")
2. Concrete
3. Anchor bolt

B: Cut this portion when this type of anchor bolt is used. If not done it will be difficult to remove the service cover

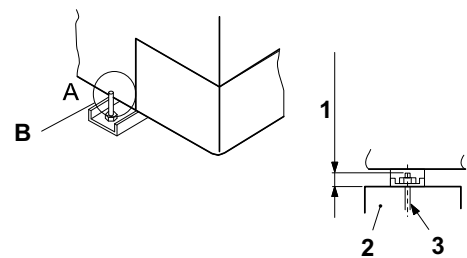

3 Provide an adequate drainage around the foundation. When installing the unit on a roof or a veranda drain water may turn to ice in a cold morning. Therefore avoid draining in an area where people often use because it is slippery. In case of installing such a place provide the additional drainage around the foundation.

1. Drain hole (30x80)
2. Drain hole (3-30x80)

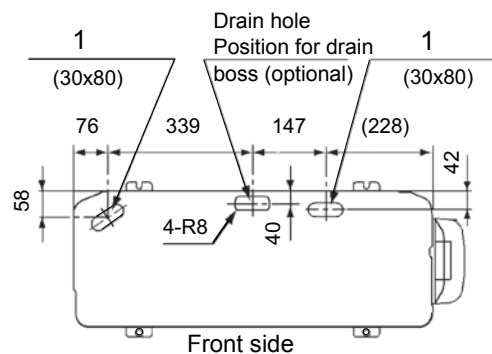

- 4 The whole of the base of the outdoor unit should be installed on a foundation. When using vibration-proof mat it should also be positioned the same way. When installing the outdoor unit on a field-supplied frame use metal plates to adjust the frame width for stable installation as shown in Figure.

1. Outdoor unit is unstable
2. Frame
3. Outdoor unit is stable
4. Metal plate

- A. 57 mm. Base width of outdoor unit
 B. 60 mm Frame width (Field-supplied)
 C. 100 mm or more Metal plate

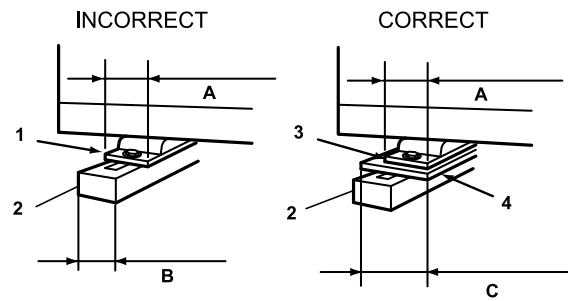

- Recommended Metal Plate Size:
 - (Field-Supplied) Material: Hot-Rolled Mild Steel.
 - Plate (SPHC) Plate Thickness: 4.5 T

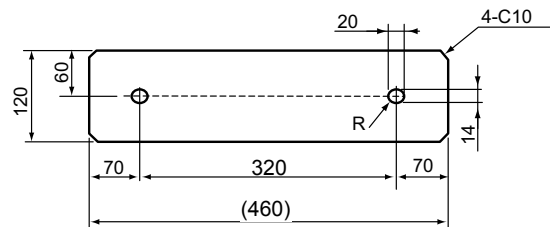

Installing location where the unit will be exposed to strong wind

Follow the instructions below to install on the rooftop or a location without surrounding buildings where strong wind is expected against the product.

- 1 Choose a location where the outlet or inlet side of the product will not be exposed to strong wind.
- 2 When the outlet is exposed to strong wind: Direct strong wind may cause lack of air flow and adversely affect to normal function.

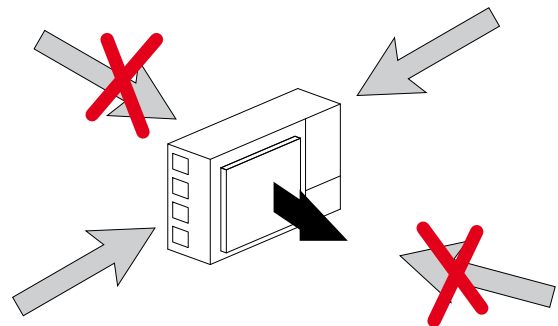

CAUTION

Excessive strong wind against the outdoor unit outlet may cause inverse rotation and damage the fan and motor.

2.6.2 Place provision for RAS-3HVNPE / RAS-(4-6)H(V)N(P/C)E / RAS-(8-10)HN(P/C)E / RAS-12HN(P/C)

◆ Concrete foundation

- Foundation could be on flat and it is recommended to be 100-300 mm higher than ground level.
- Install a drainage around foundation for smooth drain.
- When installing the outdoor unit fix it by M10 anchor bolts.
- When installing the unit on a roof or a veranda drain water sometimes turns into ice on a cold morning. Therefore avoid draining in an area that people often use because it may become slippery.

Metal plate for RAS-3HVNPE / RAS-(4-6)H(V)N(P/C)E / RAS-(8-10)HN(P/C)E / RAS-12HN(P/C)

- 1 Outdoor unit.
- 2 Cut this portion of bolt. If not it's difficult to remove Service cover.
- 3 Mortar hole (Ø100 x Depth 150).
- 4 Anchor bolt M10 (Ø12.5 Hole).
- 5 Drainage (Wide 100 x Depth 150).
- 6 Drainage.
- 7 Vibration-proof rubber.

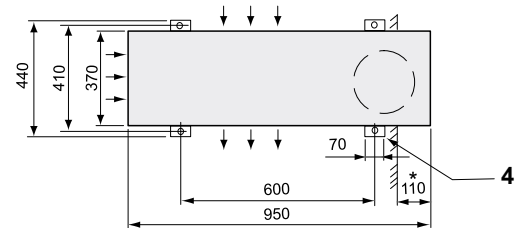
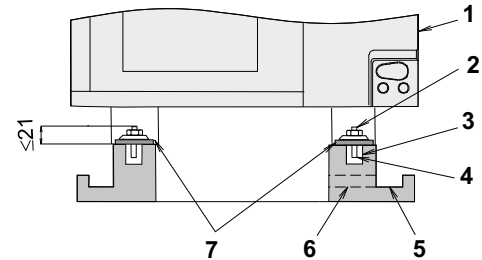

NOTE

(*): Space for downward piping space.

Anchor bolt location in case of RAS-12HN(P/C)⁽¹⁾.

The whole base of the outdoor unit should be installed on a foundation. When using vibration-proof material it should also be positioned in the same place. When installing the outdoor unit on a field-supplied frame use metal plates to adjust the frame width for stable installation as shown in the figure below.

1. Outdoor unit is unstable
 2. Frame.
 3. Outdoor unit is stable.
 4. Metal plate.
- A. For RAS-(4-10)H(V)N(P/C)E 70 mm. Base width for outdoor unit.
For RAS-12HN(P/C) 100 mm. Base width for outdoor unit.
- B. 60 mm. Frame width (Field supplied).
- C. 100 mm or more Metal plate.

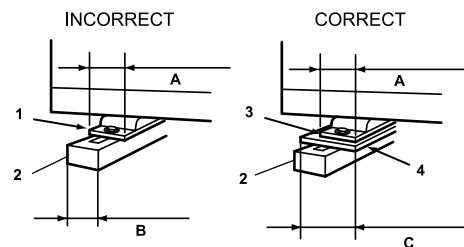

Recommended Metal Plate Size

- (Field-Supplied) Material: Hot-Rolled Mild Steel.
- Plate (SPHC) Plate Thickness: 4.5 T.

Model	RAS-3HVNPE	
	RAS-(4-6)H(V)N(P/C)E	RAS-12HN(P/C)
A (mm)	410	420
B (mm)	550	560

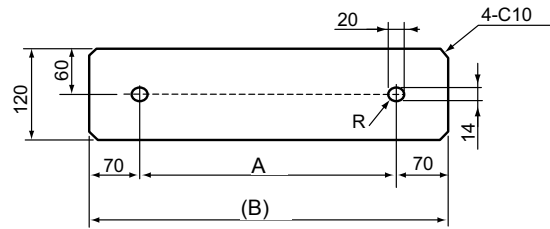

Example of fixing outdoor unit by anchor bolts

1. Max. 21 mm (After cut “A”)
2. Concrete
3. Anchor bolt

B. Cut this portion when this type of anchor bolt is used. If not done it will be difficult to remove the service cover

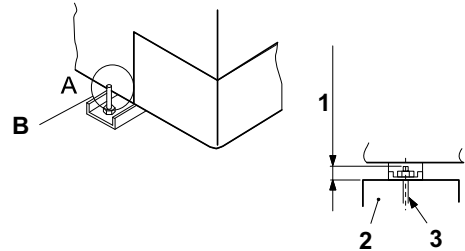

◆ **Fix unit to the wall**

- 1 Fix the unit onto the wall as shown in the figures (Field supplied bracket).
- 2 Secure the foundation to avoid noise and warping
- 3 To avoid vibrations transferring to the building use a rubber mat.

RAS-3HVNPE
RAS-(4-6)H(V)NCE

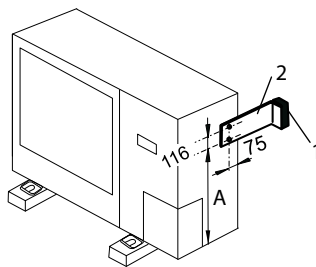

RAS-(4-6)H(V)NPE
RAS-(8-10)HN(P/C)E
RAS-12HN(P/C)

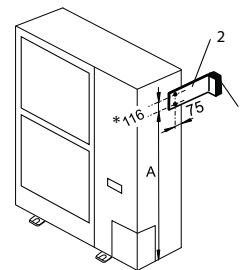

1. Rubber material
2. Fixing plate

i NOTE

- (*): In RAS-12HN(P/C) are 110 mm

Model	RAS-3HVNPE RAS-(4-6)H(V)NPE	RAS-(4-6)H(V)NCE RAS-(8-10)HN(P/C)E	RAS-12HN(P/C)
A (mm)	529	1109	1173

◆ Suspended unit

- 1 Suspend the unit as shown in the figures.
- 2 Ensure that wall can withstand the weight of the outdoor unit indicated on the specifications plate.
- 3 It is advisable that each foot support should bear the full weight of the unit (in order take account of applied stress fatigue when unit is operating).

RAS-3HVNPE
RAS-(4-6)H(V)NCE

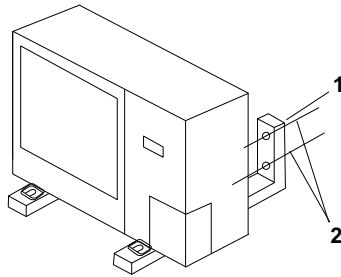

RAS-(4-6)H(V)NPE
RAS-(8-10)HN(P/C)E
RAS-12HN(P/C)

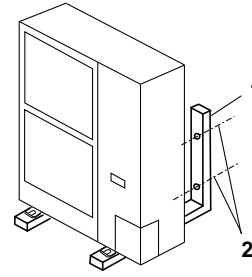

1. Wall support (field supplied)
2. Anchor bolts (field supplied)

CAUTION

- **Follow these installation procedures carefully**
 - **The installation must be done so as to ensure that the outdoor unit does not lean vibrate make a noise or fall in the event of strong gusts of wind or earthquakes. Calculate the resistance to vibration (caused by earthquakes) to guarantee that the installation is sturdy enough to prevent falls. Secure the unit with cables (field-supplied) when installing the unit in a place without walls or wind protection and where it is likely to be exposed to gusts of wind.**
 - **When using the vibration-proof rubber mat secure it at four points on the front and back.**

◆ Installing location where the unit will be exposed to strong wind

Follow the instructions below to install on the roof or in a place which is not surrounded by buildings and where the product may be buffeted by strong winds.

- 1 Select a place where the input or outlet side of the product is exposed to strong winds.
- 2 When the outlet is exposed to strong winds: Strong direct winds may cause a lack of air flow and negative effects on the unit operation.

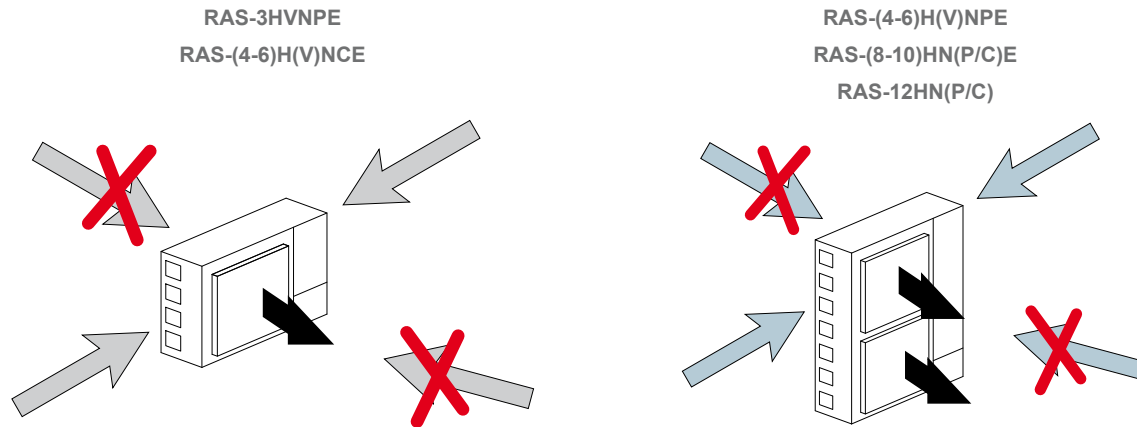

⚠ CAUTION

An excessively strong wind blowing against the outlet of the outdoor unit may cause reverse rotation and damage to the fan motor.

2.7 Optional parts and installation

2.7.1 Optional parts and installation for RAS-(2-2.5)HVNP / RAS-3HVNC

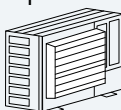
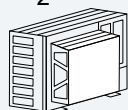
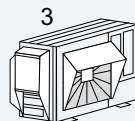
◆ Air flow guide wind guard and snow protection hood

Optional parts		Model		
Air flow guide		AG-264	 	
Wind guard		WSP-264		
Snow protection hood	Zinc Plate	Air outlet	ASG-NP80F	
		Air inlet of rear side	ASG-NP56B	
		Air inlet of side face	ASG-NP56L	
	Stainless plate (NSSC180)	Air outlet	ASG-NP80FS2	
		Air inlet of rear side	ASG-NP63B52	
		Air inlet of side face	ASG-NP63LS2	

1 Air flow guide
 2 Wind Guard
 3 Snow protection hood

◆ Air flow guide

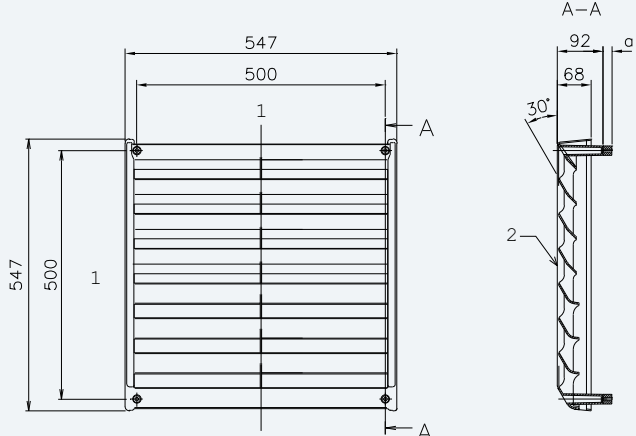
Model	AG-264	
Quantity	1 per unit	
Air discharge direction	Upward (downward) left & right	
Material	Weather proof polypropylene resin	
Color	Gray	
Weight	1.4 kg	
Accessories	Fixing screw 4x [M5 (SUS) x 12]+4x [M5 (SUS) x 30] Installation manual Self-screw 2x [M4 x 13]	
Installation restriction	"Wind Guard" or "Snow protection hood" is not available to install with air flow guide. ("Guard net" is available to be installed together.)	

1 Mounting dimension
 2 Air flow guide

Attaching example of air flow guide

- Attach the air flow guide to the air discharge grille with four (4) screws (supplied).
- The fixing holes are located at 4 positions on the grille. (Screw tightening torque 2.4 3.1 N.m)
- Do not remove the air discharge grille for air flow guide installation.



CAUTION

If the air guide is installed without discharge grille it may cause injury due to rotating fan.

Locations of fixing holes

The holes Location shall be made by using self-screws (M4x13) and later shall be used SUS screw (M5x12) for fixing air flow guide.

- 1 Outdoor Unit
- 2 Hole (4 locations)

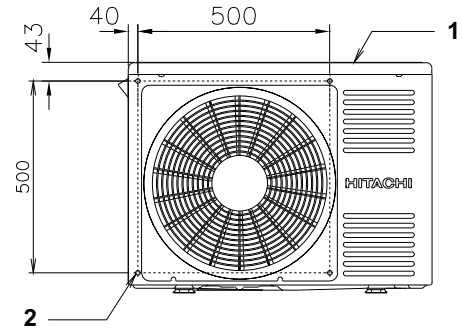

One flow guide installation

- 1 Air discharge grille
- 2 Air flow
- 3 Outdoor unit
- 4 M5 fixing screw x4 (Accessories)
- 5 Air flow guide

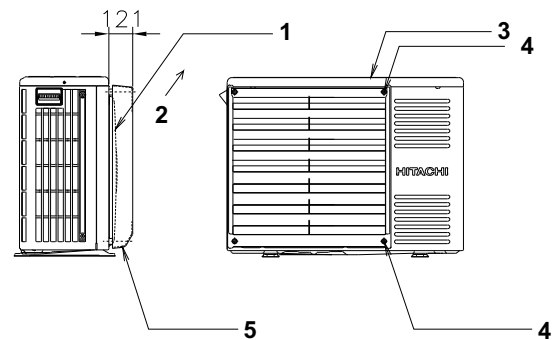

Service space (In case of upward air discharge)

- In case of right and left sides air discharge enough space for air discharge is required.
- The downward air discharge is also available. In such case install the base under the unit to secure enough space for air discharge.
- In case of serial units installation air discharge should be upward.

- 1 Min.150 mm
- 2 Outdoor unit
- 3 Air flow guide
- 4 Passage side

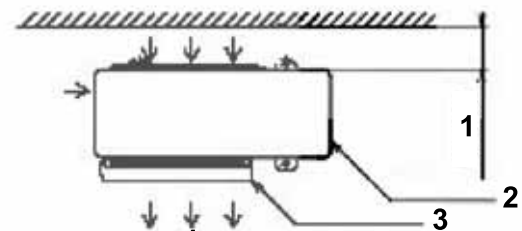

◆ Wind guard

Specifications

Model	WSP-264
Quantity	1 per unit
Material	Galvanized sheet metal + baked painting
Color	UTOPIA Beige
Weight	4.0 kg
Accessories	Fixing screw x 4 [M5 (SUS) x 30]- Unit Fixing Screw x 10 [M5 (SUS) x 12]- Wind Ward Installation manual
Installation restriction	"Guard net" "Air flow guide" or "Snow protection hood" is not available to install with Wind guard

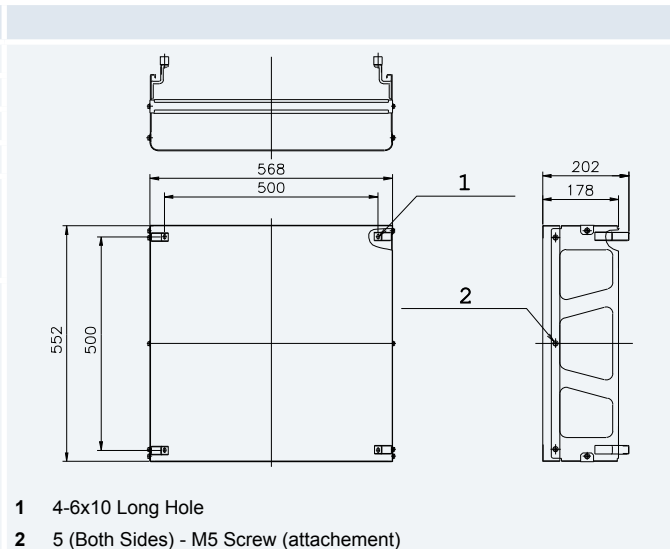

2

Attaching example of air wind guard

- Attach the air flow guide to the air discharge grille with four (4) screws (supplied).
- The fixing holes are located at 4 positions on the grille. (Screw tightening torque 2.4 3.1 N.m)
- Do not remove the air discharge grille for air flow guide installation.

⚠ CAUTION

- *If the air guide is installed without discharge grille it may cause injury due to rotating fan.*

Two windguard covers installation

- 1 Air discharge grille
- 2 Outdoor unit
- 3 M5 fixing screw x4 (Accessories)

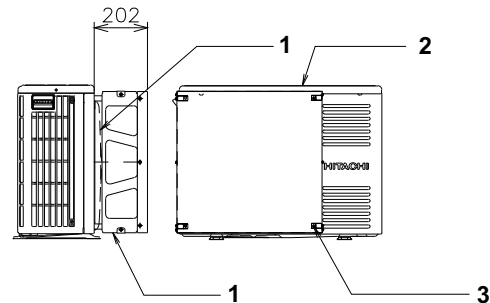

Service space

- Both sides of the outdoor unit should be open.
- No obstacles should be placed in the air discharge side.

- 1 Min. 150 mm
- 2 Outdoor unit
- 3 Wind guard

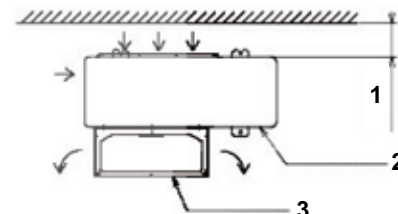

◆ Snow protection hood

Air discharge hood

N°	Part name	Quantity
1	Right side plate	1
2	Left side plate	1
3	Front panel	1
4	Fixing screw (Accessories)	
5	Hole for safety wire rope to prevent overturning	

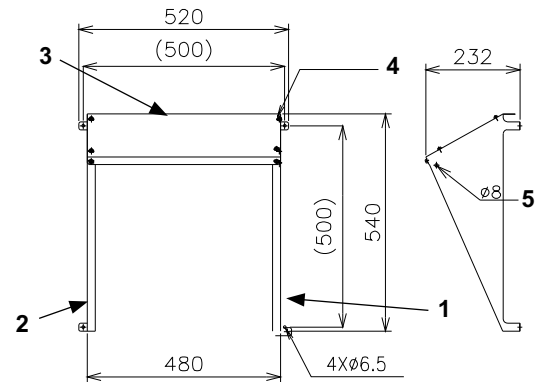

Rear suction hood

N°	Part name	Quantity
1	Right side plate	1
2	Left side plate	1
3	Upper front panel (Upside)	1
4	Upper front panel (Downside).	1
5	Hole for safety wire rope to prevent overturning	
6	Fixing screw (Accessories)	

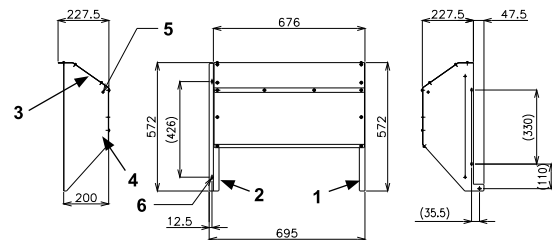

Left suction hood

N°	Part name	Quantity
1	Right side plate	1
2	Left side plate	1
3	Upper front panel (Upside)	1
4	Upper front panel (Downside).	1

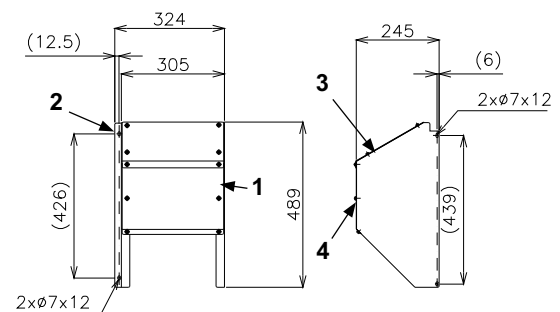

Attaching example of snow protection hood

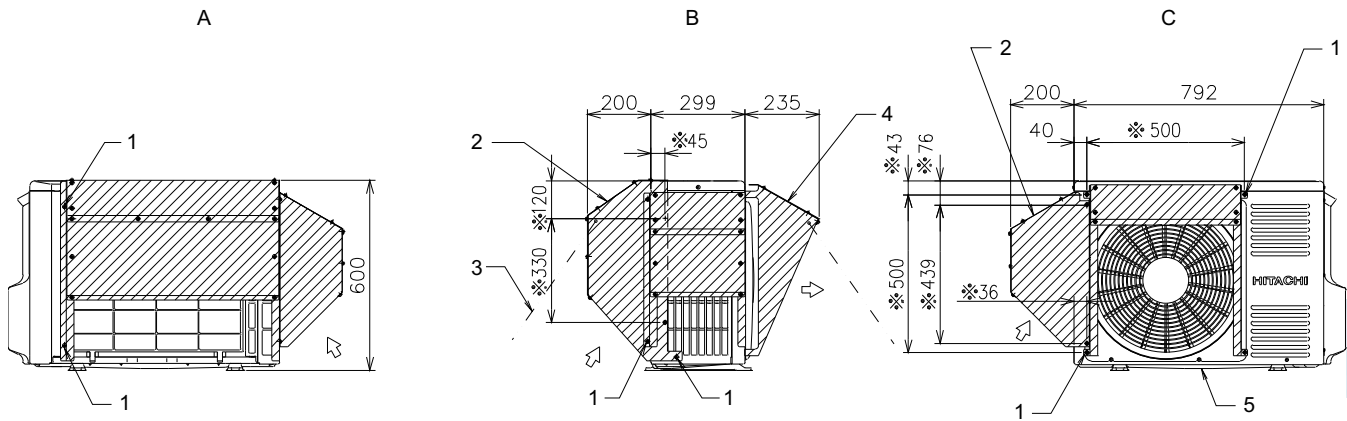

2

1. Fixing screw (accessories)
 2. Air inlet hood
 3. Wire rope (optional for over turning protection)
 4. Air discharge hood
 5. Outdoor unit
- A. Rear side
B. Left side
C Front side



NOTE

- **The holes locations marked with a mark shall be made by using sel screw (M4X13) and later shall be used SUS Screw for fixing protection hood.**

Specifications of snow protection hood

Product name		Air discharge hood		Rear suction hood		Left suction hood	
Model		ASG-NP80F	ASG-NP80FS	ASG-NP56B	ASG-NP63BS2	ASG-NP56L	ASG-NP63LS2
Quantity		1 per unit					
Material		Bonderized steel sheet Iron	Stainless (NSSC180)	Bonderized steel sheet Iron	Stainless (NSSC180)	Bonderized steel sheet Iron	Stainless (NSSC180)
Color		Gray (1.0Y8.5/0.5 or approximation)	—	Gray (1.0Y8.5/0.5 or approximation)	—	Gray (1.0Y8.5/0.5 or approximation)	—
Weight		3 kg		6 kg		3 kg	
Assembling		Knockingdown parts (assembled at field)					
Components	Hood	For air discharge part x 1		For rear side air intake x 1		For left side air intake x 1	
	Unit						
	Fixing screw	4 (M5x12 tapping screw)		5 (M5x12 tapping screw)		4 (M5x12 tapping screw)	
	Hood						
	Fixing screw (SUS)	6 (M5x12 tapping screw)	6 (M5x14)	14 (M5x12 tapping screw)	14 (M5x14)	10 (M5x12 tapping screw)	10 (M5x14)
	Self-screw	2 (M4x13)		2 (M4x13)		2 (M4x13)	
		Installation manual					
Installation restriction		Installation with "Guard net" "Wind guard" or is not available		Installation with "Guard net" is not available			
Safety wire rope for overturning prevention (optional parts)		ASG-SW20A					

2.7.2 Optional parts and installation RAS-3HVNPE / RAS-(4-6)H(V)NCE

◆ Air flow guide wind guard and snow protection hood

Optional parts		Model	
Air flow guide		AG-335A	1
Wind guard		WSP-335A	
Snow protection hood	Zinc plate	Air outlet	2
		Air inlet of rear side	
		Air inlet of side face	
	Stainless plate (SUS304)	Air outlet	3
		Air inlet of rear side	
		Air inlet of side face	

- 1 Air flow guide
 2 Wind Guard
 3 Snow protection hood

◆ Air flow guide

Specifications

Model	AG-335A	
Quantity	1 per unit	
Air discharge direction	Upward (downward) left & right	
Material	Weather proof polypropylene resin	
Color	Gray	
Weight	1.9 kg	
Accessories	Fixing screw x 4 [M5 (SUS) x 20] Installation manual	
Installation restriction	"Wind Guard" or "Snow protection hood" is not available to install with air flow guide. ("Guard net" is available to be installed together.)	

- 1 Mounting dimension
 2 Air flow guide

Attaching example of air flow guide

- Attach the air flow guide to the air discharge grille with four (4) screws (supplied).
- The fixing holes are located at 4 positions on the grille. (Screw tightening torque 2.4 3.1 N.m)
- Do not remove the air discharge grille for air flow guide installation.

⚠ CAUTION

- **If the air guide is installed without discharge grille it may cause injury due to rotating fan.**

One flow guide installation

- 1 Air discharge grille
- 2 Air flow
- 3 Air flow guide
- 4 Outdoor unit
- 5 M5 fixing screw x4 (Accessories)

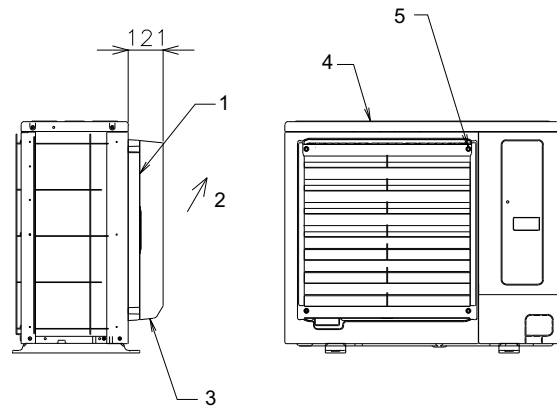

2

Service space (In case of upward air discharge)

- In case of right and left sides air discharge enough space for air discharge is required.
- The downward air discharge is also available. In such case install the base under the unit to secure enough space for air discharge.
- In case of serial units installation air discharge should be upward.

- 1 Min. 200 mm
- 2 Outdoor unit
- 3 Air flow guide
- 4 Passage side

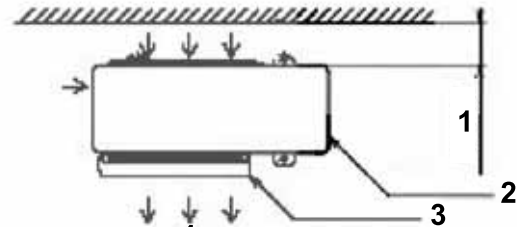

◆ Wind guard

Specifications

Model	WSP-335A
Quantity	1 per unit
Material	Galvanized sheet metal + baked painting
Color	Gray (1.0Y8.5/0.5)
Weight	5.5 kg
Accessories	Fixing screw x 4 [M5 (SUS) x 12] Installation manual
Installation restriction	"Guard net" "Air flow guide" or "Snow protection hood" is not available to install with Wind guard

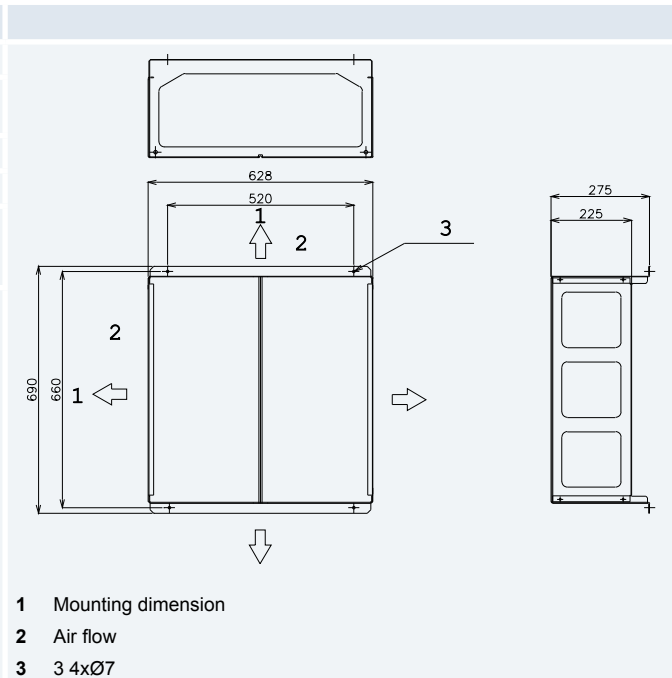

Attaching example of air wind guard

- Attach the air flow guide to the air discharge grille with four (4) screws (supplied).
- The fixing holes are located at 4 positions on the grille. (Screw tightening torque 2.4 3.1 N.m)
- Do not remove the air discharge grille for air flow guide installation.



CAUTION

- **If the air guide is installed without discharge grille it may cause injury due to rotating fan.**

One windguard cover installation

- 1 Air discharge grille
- 2 Wind guard
- 3 Air discharge grille
- 4 Outdoor unit
- 5 M5 fixing screw x4 (Accessories)

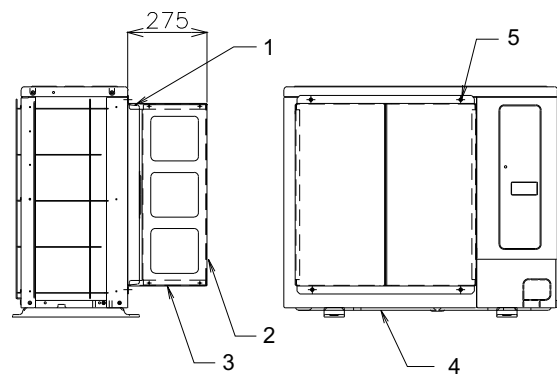

Service space

- Both sides of the outdoor unit should be open.
- No obstacles should be placed in the air discharge side.

- 1 Min. 200 mm
- 2 Outdoor unit
- 3 Wind guard

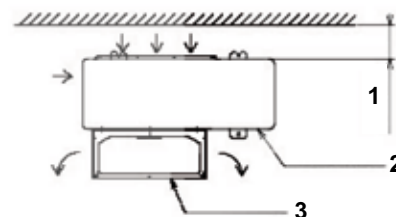

Snow protection hood

Air discharge hood

N°	Part name	Quantity
1	Right side plate	1
2	Left side plate	1
3	Front panel	1
4	Stay	4
5	Fixing screw (Accessories)	
6	Hole for safety wire rope to prevent overturning	

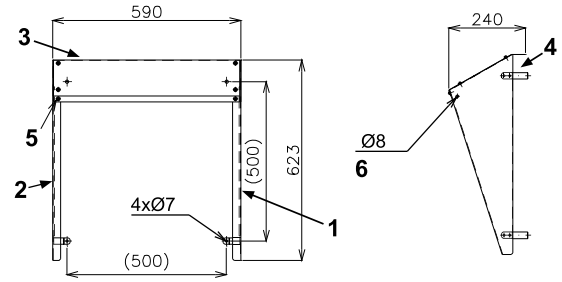

Rear suction hood

N°	Part name	Quantity
1	Right side plate	1
2	Left side plate	1
3	Upper front panel (Upside)	1
4	Upper front panel (Downside)	1
5	Fixing screw (Accessories)	
6	Hole for safety wire rope to prevent overturning	

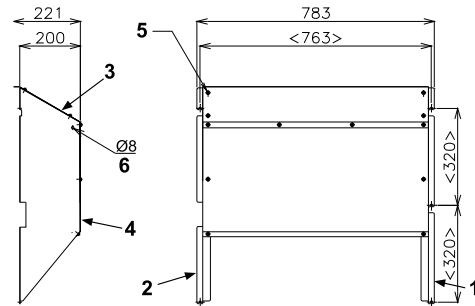

Left suction hood

N°	Part name	Quantity
1	Right side plate	1
2	Left side plate	1
3	Front panel (Upside)	1
4	Front panel (Downside)	1
5	Fixing hole x 2	
6	Fixing screw (Accessories)	
A	Enlarged view of A (Fixing Hole)	

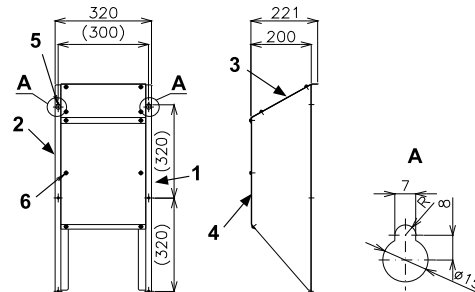

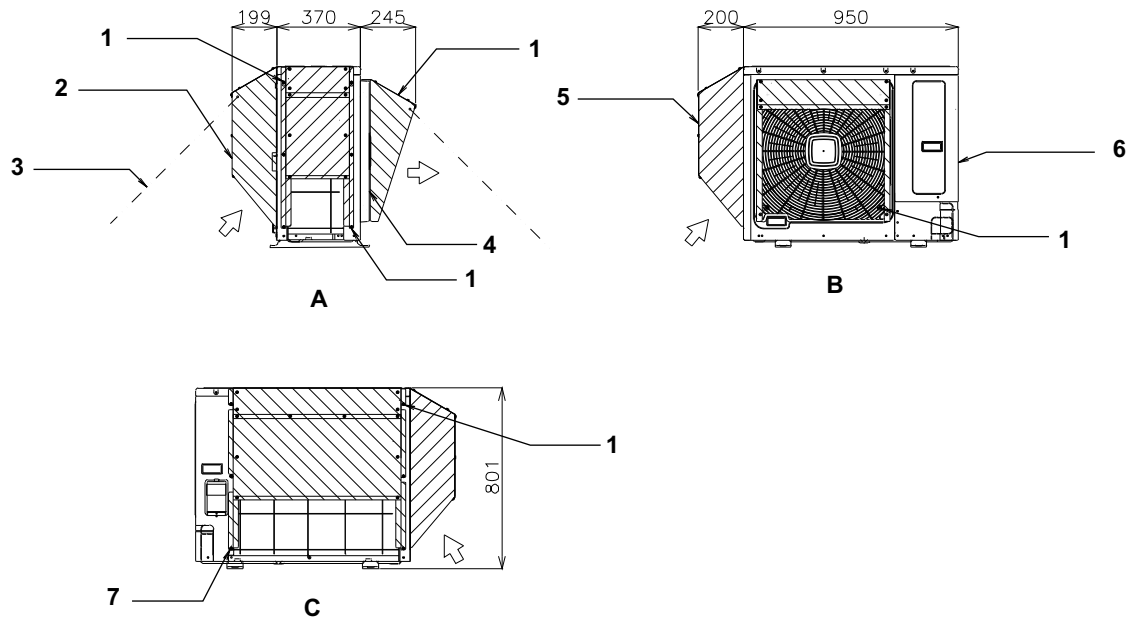
Attaching example of snow protection hood

1. Fixing screw (Accessories).

2. Rear suction hood

3. Wire rope (Optional. For overturning protection)

4. Air discharge grille

5. Left suction hood

6. Air discharge hood

A. Left side

B. Front side

C. Rear side

Specifications of snow protection hood

Product name		Air discharge hood		Rear suction hood		Left suction hood	
Model		ASG-NP335F	ASG-NP335FS2	ASG-NP80B	ASG-NP160BS2	ASG-NP80L	ASG-NP160LS2
Quantity		2 per unit		1 per unit			
Material		Bonderized steel sheet Iron	Stainless (NSSC 180)	Bonderized steel sheet Iron	Stainless (NSSC 180)	Bonderized steel sheet Iron	Stainless (NSSC 180)
Color		Gray (1.0Y8.5/0.5 or approximation)	—	Gray (1.0Y8.5/0.5 or approximation)	—	Gray (1.0Y8.5/0.5 or approximation)	—
Weight		3 kg		14 kg		8 kg	
Assembling		Knockingdown parts (assembled at field)					
Components	Hood	For air discharge part x 1		For rear side air intake x 1 (Upper side x 1 lowe side x 1)		For left side air intake x 1	
	Unit Fixing screw	4 (M5x12 tapping screw)		5 (M5x14 tapping screw)		6 (M5x12 tapping screw)	
	Unit Fixing screw (SUS)	6 (M5x12 tapping screw)	6 (M5x14)	12 (M5x12 tapping screw)	12 (M5x14)	10 (M5x12 tapping screw)	10 (M5x14)
		Installation manual					
Installation restriction		Installation with "Guard net" or "Wind guard" is not available		Installation with "Guard net" is not available			
Safety wire rope for overturning prevention (optional parts)		ASG-SW20A					

2.7.3 Optional parts and installation RAS-(4-6)H(V)NPE / RAS-(8-10)HN(P/C)E

◆ Air flow guide wind guard and snow protection hood

Optional parts		Model		
Air flow guide		AG-335A X 2	 	
Wind guard		WSP-335A X 2		
Snow protection hood	Zinc plate	Air outlet	ASG-NP335F X 2	
		Air inlet of rear side	ASG-NP280B	
		Air inlet of side face	ASG-NP280L	
	Stainless plate (NSSC 180)	Air outlet	ASG-NP335FS 2X 2	
		Air inlet of rear side	ASG-280BS2	
		Air inlet of side face	ASG-NP280LS2	

1 Air flow guide
 2 Wind Guard
 3 Snow protection hood

◆ Air flow guide

Specifications

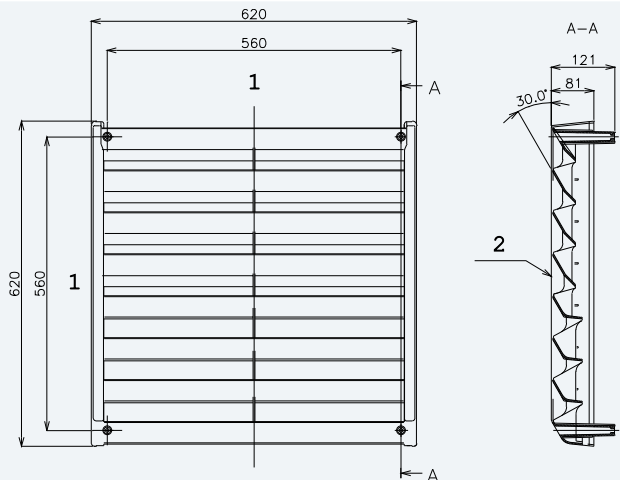
Model	AG-335A	Image
Quantity	2 per unit	
Air discharge direction	Upward (downward) left & right	
Material	Weather proof polypropylene resin	
Color	Gray	
Weight	1.9 kg	
Accessories	Fixing screw x 4 [M5 (SUS) x 20] Installation manual	
Installation restriction	"Wind Guard" or "Snow protection hood" is not available to install with air flow guide. ("Guard net" is available to be installed together.)	

1 Mounting dimension
 2 Air flow guide

Attaching example of air flow guide

- Attach the air flow guide to the air discharge grille with four (4) screws (supplied).
- The fixing holes are located at 4 positions on the grille. (Screw tightening torque 2.4 3.1 N.m)
- Do not remove the air discharge grille for air flow guide installation.

CAUTION

- *If the air guide is installed without discharge grille it may cause injury due to rotating fan.*

Two flow guides installation

- 1 Air discharge grille
- 2 Air flow
- 3 Air flow guide (see the note)
- 4 Outdoor Unit
- 5 M5 fixing screw x4 (Accessories)



NOTE

- **Air flow direction of both air flow guides should be the same.**

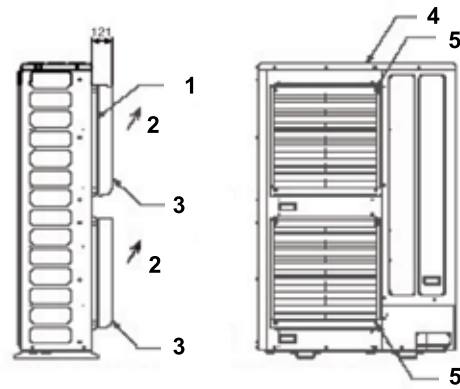

Service space (In case of upward air discharge)

- In case of right and left sides air discharge enough space for air discharge is required.
- The downward air discharge is also available. In such case install the base under the unit to secure enough space for air discharge.
- In case of serial units installation air discharge should be upward.

- 1 Min. 200 mm
- 2 Outdoor unit
- 3 Air flow guide
- 4 Passage side

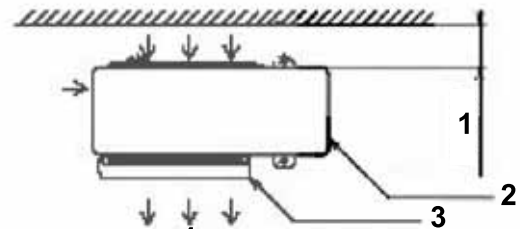

◆ **Wind guard**

Specifications

Model	WSP-335A
Quantity	2 per unit
Material	Galvanized sheet metal + baked painting
Color	Gray (1.0Y8.5/0.5)
Weight	5.5 kg
Accessories	Fixing screw x 4 [M5 (SUS) x 12] Installation manual
Installation restriction	"Guard net" "Air flow guide" or "Snow protection hood" is not available to install with Wind guard

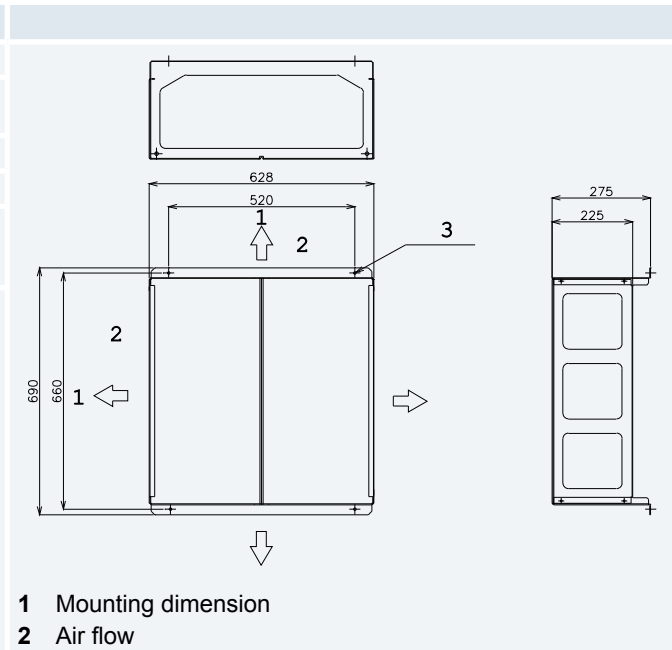

Attaching example of air wind guard

- Attach the air flow guide to the air discharge grille with four (4) screws (supplied).
- The fixing holes are located at 4 positions on the grille. (Screw tightening torque 2.4 3.1 N.m)
- Do not remove the air discharge grille for air flow guide installation.

CAUTION

If the air guide is installed without discharge grille it may cause injury due to rotating fan.

Two windguard covers installation

- 1 Air discharge grille
- 2 Wind guard
- 3 Outdoor unit
- 4 M5 fixing screw x4 (Accessories)

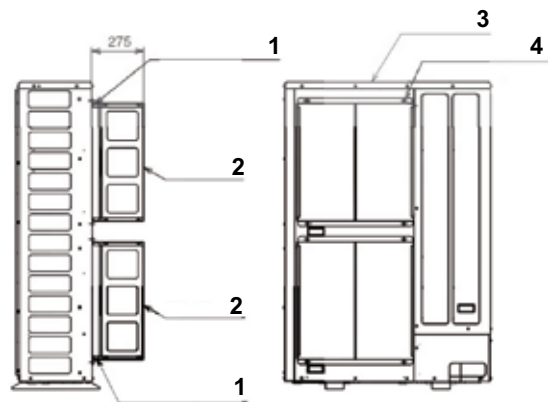

Service space

- Both sides of the outdoor unit should be open.
- No obstacles should be placed in the air discharge side.

- 1 Min. 200 mm
- 2 Outdoor unit
- 3 Wind guard

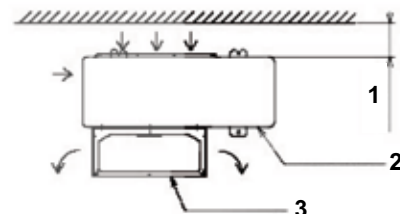

◆ **Snow protection hood**

Air discharge hood

N°	Part name	Quantity
1	Right side plate	1
2	Left side plate	1
3	Front panel	1
4	Stay	4
5	Fixing screw (Accessories)	
6	Hole for safety wire rope to prevent overturning	

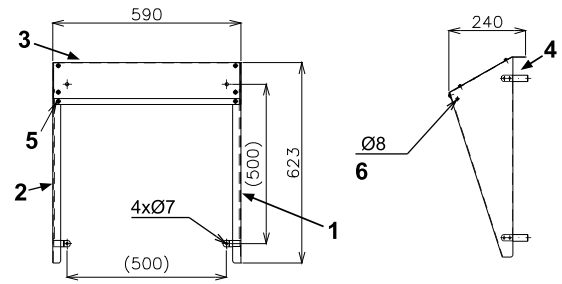

Rear suction hood

N°	Part name	Quantity
1	Right side plate	1
2	Left side plate	1
3	Upper front panel (Upside)	1
4	Upper front panel (Downside)	1
5	Fixing screw (Accessories)	
6	Hole for safety wire rope to prevent overturning	

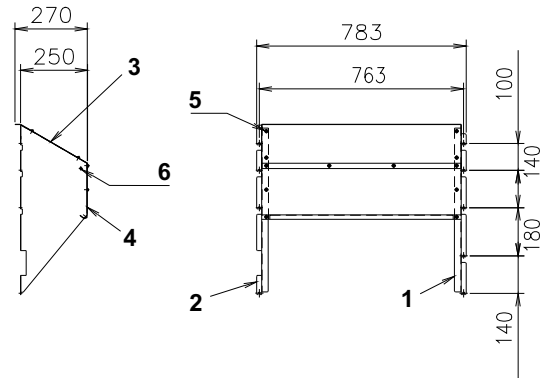

Left suction hood

N°	Part name	Quantity
1	Right side plate	1
2	Left side plate	1
3	Front panel (Upside)	1
4	Front panel (Downside)	1
5	Fixing hole x 2	
6	Fixing screw (Accessories)	
A	Enlarged view of A (Fixing Hole)	

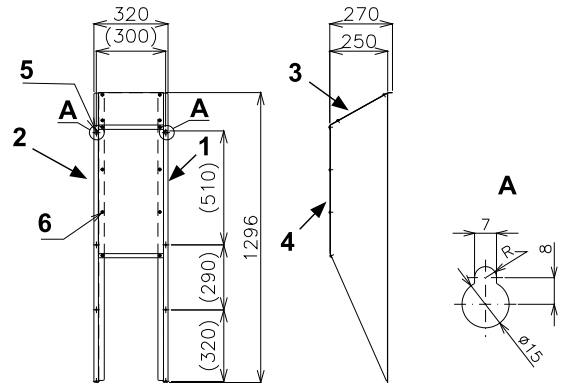

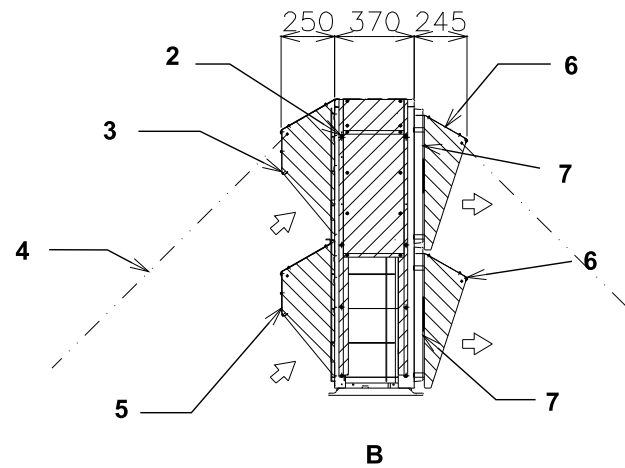
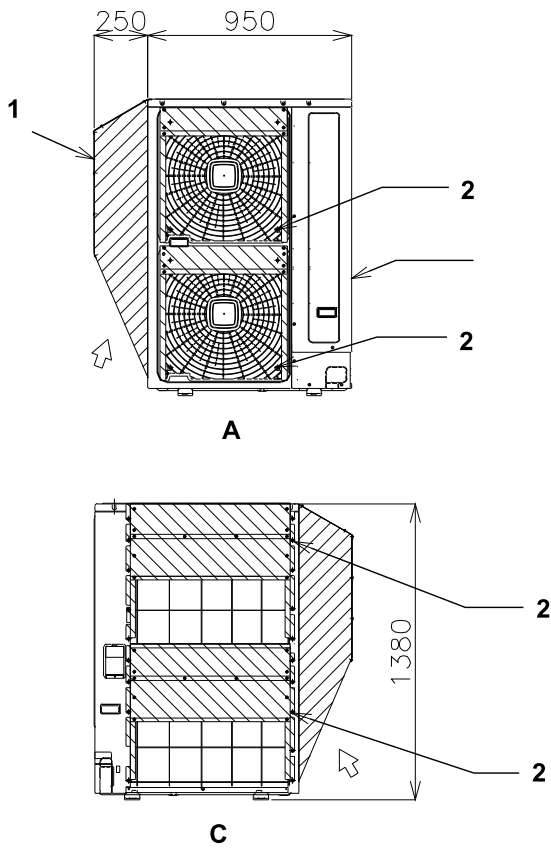
Attaching example of snow protection hood

1. Left suction hood
 2. Fixing screw (Accessories)
 3. Rear suction hood Upper side
 4. Wire rope (Optional. For overturning protection)
 5. Rear suction hood Lower side
 6. Air discharge hood
 7. Air discharge grille
 8. Air discharge grille
- A. Front side
 B. Left side
 C. Rear side

Specifications of snow protection hood

Product name		Air discharge hood		Rear suction hood		Left suction hood	
Model		ASG-NP335F	ASG-NP335FS2	ASG-NP280B	ASG-NP280BS2	ASG-NP280L	ASG-NP280LS2
Quantity		2 per unit		1 per unit			
Material		Bonderized steel sheet Iron	Stainless (NSSC 180)	Bonderized steel sheet Iron	Stainless (NSSC 180)	Bonderized steel sheet Iron	Stainless (NSSC 180)
Color		Gray (1.0Y8.5/0.5 or approximation)	—	Gray (1.0Y8.5/0.5 or approximation)	—	Gray (1.0Y8.5/0.5 or approximation)	—
Weight		3 kg		14 kg		8 kg	
Assembling		Knockingdown parts (assembled at field)					
Components	Hood	For air discharge part x 1		For rear side air intake x 1 (Upper side x 1 lower side x 1)		For left side air intake x 1	
	Fixing screw	4 (M5x12 tapping screw)		11 (M5x14 tapping screw)		8 (M5x12 tapping screw)	
	Fixing screw (SUS)	6 (M5x14 tapping screw)	6 (M5x14)	24 (M5x14 tapping screw)	24 (M5x14)	12 (M5x12 tapping screw)	12 (M5x14)
		Installation manual					
Installation restriction		Installation with "Guard net" "Wind guard" or "Air flow guide" is not available		Installation with "Guard net" is not available			
Safety wire rope for overturning prevention (optional parts)		ASG-SW20A					

2.7.4 Optional parts and installation RAS-12HN(P/C)

◆ Air flow guide wind guard and snow protection hood

Optional parts			Model		
Air flow guide			AG-335A X 2	1	2
Wind guard			WSP-335A X 2		
Snow protection hood	Zinc plate	Air outlet	ASG-NP335F X 2	3	
		Air inlet of rear side	ASG-NP335B		
		Air inlet of side face	ASG-NP335L		
	Stainless plate(NSSC 180)	Air outlet	ASG-NP335FS2 X 2		
		Air inlet of rear side	ASG-335BS2		
		Air inlet of side face	ASG-NP335LS2		

1 Air flow guide
2 Wind Guard
3 Snow protection hood

◆ Air flow guide

Specifications

Model	AG-335A
Quantity	2 per unit
Air discharge direction	Upward (downward) left & right
Material	Weather proof polypropylene resin
Color	Gray
Weight	1.9 kg
Accessories	Fixing screw x 4 [M5 (SUS) x 20] Installation manual
Installation restriction	"Wind Guard" or "Snow protection hood" is not available to install with air flow guide. ("Guard net" is available to be installed together.)

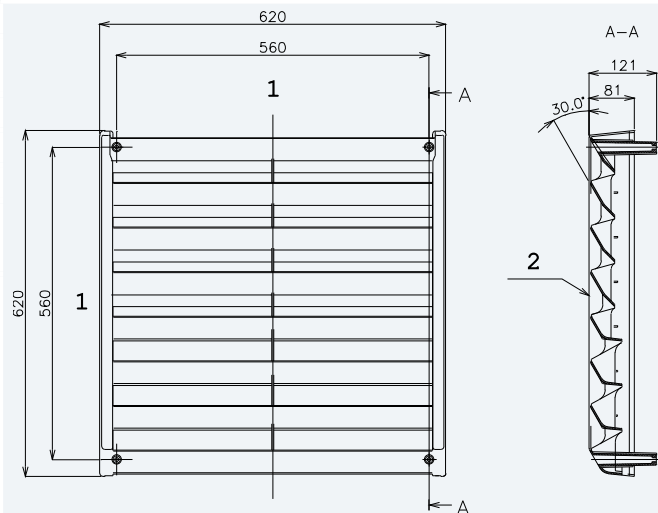

1 Mounting dimension
2 Air flow guide

Attaching example of air flow guide

- Attach the air flow guide to the air discharge grille with four (4) screws (supplied).
- The fixing holes are located at 4 positions on the grille. (Screw tightening torque 2.4 3.1 N.m)
- Do not remove the air discharge grille for air flow guide installation.



CAUTION

- **If the air guide is installed without discharge grille it may cause injury due to rotating fan.**

Two flow guides installation

- 1 Air discharge grille
- 2 Air flow
- 3 Air flow guide (see the note)
- 4 Outdoor Unit
- 5 M5 fixing screw x4 (Accessories)



NOTE

Air flow direction of both air flow guides should be the same.

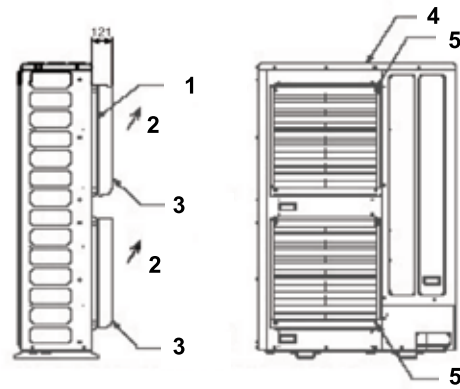

Service space (In case of upward air discharge)

- In case of right and left sides air discharge enough space for air discharge is required.
- The downward air discharge is also available. In such case install the base under the unit to secure enough space for air discharge.
- In case of serial units installation air discharge should be upward.

- 1 Min. 200 mm
- 2 Outdoor unit
- 3 Air flow guide
- 4 Passage side

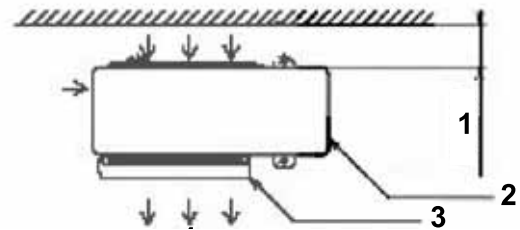

◆ Wind guard

Specifications

Model	WSP-335A	
Quantity	2 per unit	
Material	Galvanized sheet metal + baked painting	
Color	Gray (1.0Y8.5/0.5)	
Weight	5.5 kg	
Accessories	Fixing screw x 4 [M5 (SUS) x 12] Installation manual	
Installation restriction	"Guard net" "Air flow guide" or "Snow protection hood" is not available to install with Wind guard	

2

Attaching example of air wind guard

- Attach the air flow guide to the air discharge grille with four (4) screws (supplied).
- The fixing holes are located at 4 positions on the grille. (Screw tightening torque 2.4 3.1 N.m)
- Do not remove the air discharge grille for air flow guide installation.



CAUTION

If the air guide is installed without discharge grille it may cause injury due to rotating fan.

Two windguard covers installation

- 1 Air discharge grille
- 2 Wind guard
- 3 Outdoor unit
- 4 M5 fixing screw x4 (Accessories)

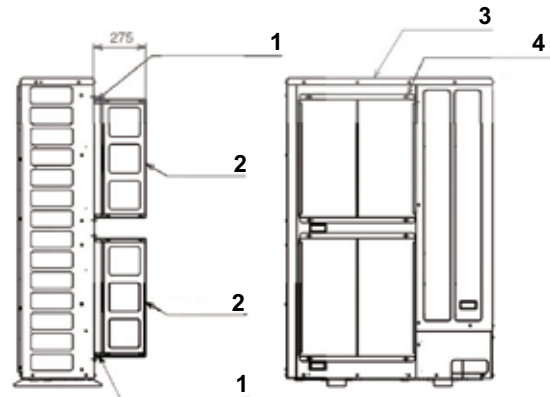

Service space

- Both sides of the outdoor unit should be open.
- No obstacles should be placed in the air discharge side.

- 1 Min. 200 mm
- 2 Outdoor unit
- 3 Wind guard

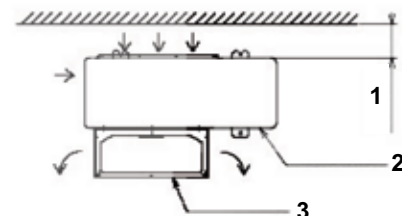

◆ **Snow protection hood**

Air discharge hood

Nº	Part name	Quantity
1	Right side plate	1
2	Left side plate	1
3	Front panel	1
4	Stay	4
5	Fixing screw (Accessories)	
6	Hole for safety wire rope to prevent overturning	

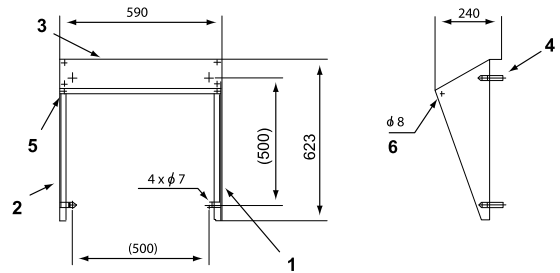

Rear suction hood

Nº	Part name	Quantity
1	Right side plate	1
2	Left side plate	1
3	Upper front panel (Downside)	1
4	Upper front panel (Upside)	1
5	Fixing screw (Accessories)	
6	Hole for safety wire rope to prevent overturning	

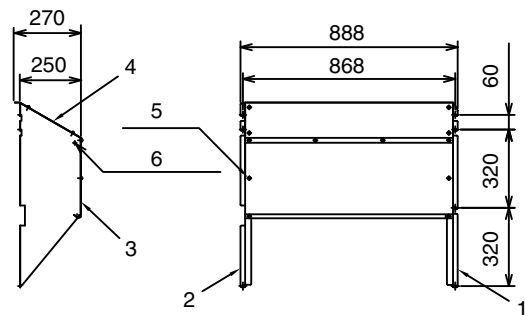

Left suction hood

Nº	Part name	Quantity
1	Right side plate	1
2	Left side plate	1
3	Front panel (upside)	1
4	Front side (downside)	1
5	Fixing hole x 2	
6	Fixing screw (Accessories)	

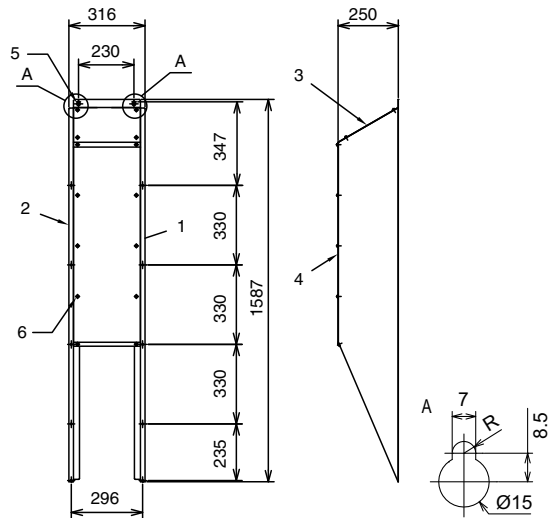

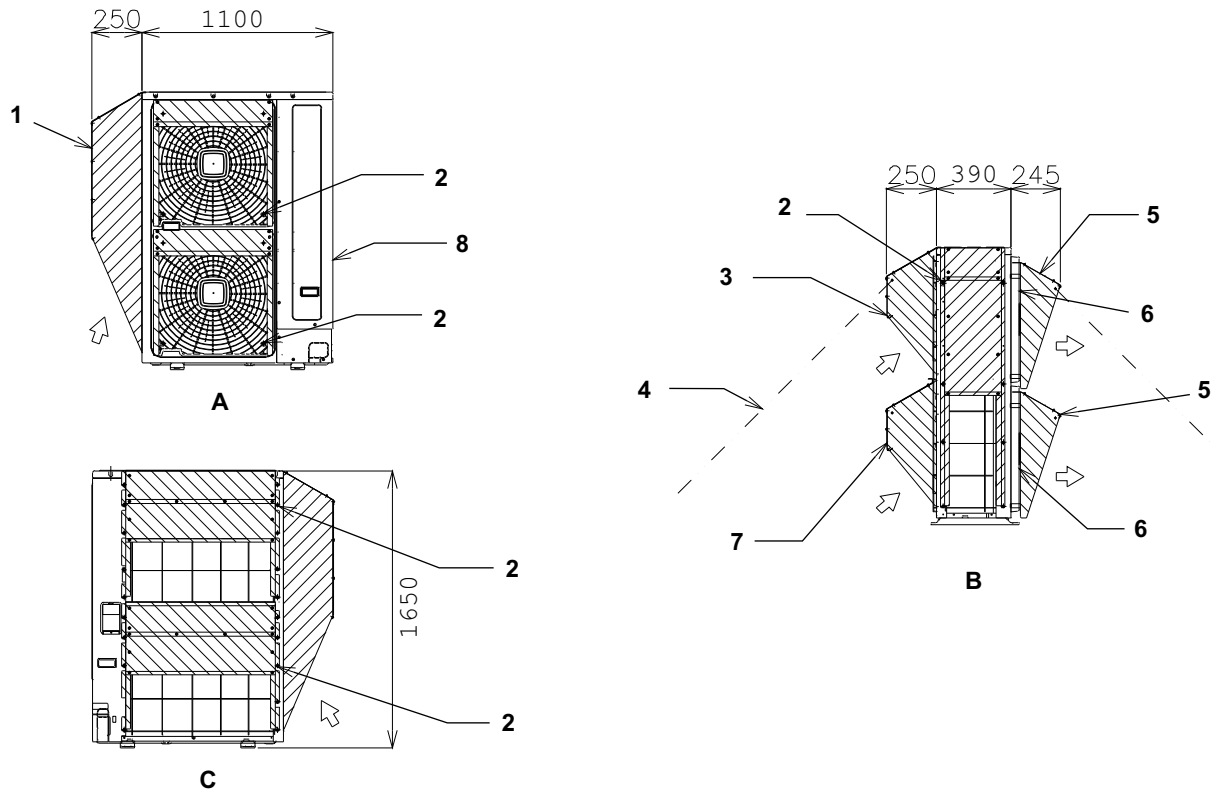
Attaching example of snow protection hood

2

1. Left suction hood
 2. Fixing screw (Accessories)
 3. Rear suction hood Upper side
 4. Wire rope (Optional. For overturning protection)
 5. Air discharge hood
 6. Air discharge grille
 7. Rear suction hood Lower side
 8. Outdoor unit
- A. Front side
 B. Left side
 C. Rear side

Specifications of snow protection hood

Product name		Air discharge hood		Rear suction hood		Left suction hood	
Model		ASG-NP335F	ASG-NP335FS2	ASG-NP335B	ASG-NP335BS2	ASG-NP335L	ASG-NP335LS2
Quantity		2 per unit		1 per unit			
Material		Bonderized steel sheet Iron	Stainless (NSSC180)	Bonderized steel sheet Iron	Stainless (NSSC180)	Bonderized steel sheet Iron	Stainless (NSSC180)
Color		Gray (1.0Y8.5/0.5 or approximation)	—	Gray (1.0Y8.5/0.5 or approximation)	—	Gray (1.0Y8.5/0.5 or approximation)	—
Weight		3 kg		14 kg		8 kg	
Assembling		Knockingdown parts (assembled at field)					
Components	Hood	For air discharge part x 1		For rear side air intake x 1 (Upper side x 1 lower side x 1)		For left side air intake x 1	
	Fixing screw	4x(M5x12 l tapping screw)		10x (M5x14 l tapping screw)		8x (M5x12 l tapping screw)	
	Fixing screw (SUS)	6x (M5x12 l tapping screw)	6x (M5x14 l)	24x (M5x14 l tapping screw)	24x (M5x14l)	14x (M5x12 tapping screw)	14x (M5x14)
		Installation manual					
Installation restriction		Installation with "Guard net" "Wind guard" or "Air flow guide" is not available		Installation with "Guard net" is not available			
Safety wire rope for overturning prevention (optional parts)		ASG-SW20A					

3. Piping work and refrigerant charge

3

Index

3.1.	General notes before performing pipe work	52
3.1.1.	Piping Materials	52
3.1.2.	Three principles on refrigerant piping work	54
3.1.3.	Suspension of refrigerant piping	54
3.1.4.	Brazing work	55
3.2.	Piping connection for outdoor unit	56
3.2.1.	RAS-(2-2.5)HVNP / RAS-3HVNC	56
3.2.2.	RAS-3HVNPE / RAS-(4-6)H(V)N(P/C)E / RAS-(8-10)HN(P/C)E / RAS-12HN(P/C)	57
3.2.3.	Outdoor unit stop valve	60
3.3.	Refrigerant piping range	62
3.3.1.	Refrigerant piping length	62
3.3.2.	Piping system for header branch	62
3.3.3.	Piping system for line branch	65
3.3.4.	Combinations of piping size and piping length	66
3.3.5.	Refrigerant piping size and multikit/distributor selection	67
3.3.6.	System installation	70
3.3.7.	Connecting flare adapter	71
3.4.	Refrigerant charge	72
3.4.1.	Caution of the pressure by check joint	73
3.4.2.	Refrigerant charge quantity	74
3.5.	Caution in case of refrigerant leakage	78
3.5.1.	Maximum permitted concentration of hydrofluorocarbon (HFC)	78
3.5.2.	Calculation of refrigerant concentration	78
3.5.3.	Countermeasure for refrigerant leakage	78
3.6.	Piping work for compatibility with the piping of current installations where is used R22 or R407C.	79
3.6.1.	Installation procedure for existing pipes	79
3.6.2.	When existing Air-Conditioner is a product of another manufacturer	79
3.6.3.	Permissible range for existing Air-Conditioning Pipes (Pipe length in the case of "without cleaning process"	80
3.6.4.	Renewal kit selection model	81
3.7.	Drain piping	85
3.7.1.	Drain discharging boss	85

3.1 General notes before performing pipe work

3.1.1 Piping Materials

1 In order to avoid supply problems in terms of local regulations and quality, prepare locally-supplied copper pipes.



NOTE

In case of using copper pipes for piping sections bigger than $\varnothing 19.05$ mm (3/4 inches), flaring work cannot be performed. If necessary, use a joint adapter.

- 2 Select the piping size with the correct thickness and correct material able to withstand sufficient pressure.
- 3 Select clean copper pipes. Make sure there is no dust and moisture inside. Blow the inside of the pipes through with oxygen-free nitrogen to remove any dust and foreign materials before connecting pipes.
- 4 After connecting the refrigerant piping, seal the open space between the knockout hole and refrigerant pipes by using insulation material as shown below:

A. Insulator material.

B. Field-supplied refrigeration pipe.

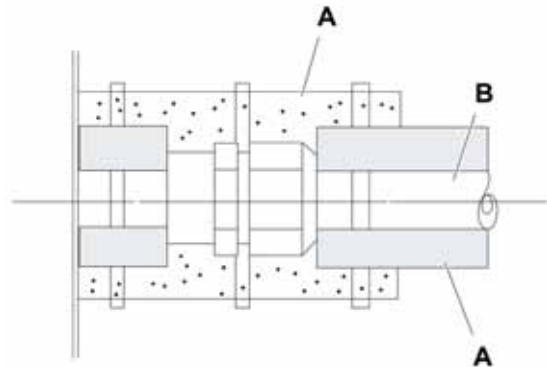

CAUTION

- **Do not use saws, grindstones or other tools which cause copper powder.**
- **When cutting pipes, secure the part for brazing in accordance with both national and local regulations.**
- **Use security glasses and gloves for cutting or welding works.**

◆ Piping Connection

When connecting liquid piping for units with piping longer than 15 meters, apply a piping size of $\varnothing 9.52$ mm (3/8 inches). Fix the connecting pipe as shown in the following figure using the insulation attached to the Indoor Unit.

A. Use the flare nut of the indoor unit.

B. Insulate this part with the attached insulation.

C. Fix this part with the attached cord band or with tape.

D. Field-supplied refrigerant piping.

E. Field-supplied insulation.

F. Brazing.

G. Make flares after attaching flare nut to the connecting pipe in the Multi-kit package.

H. Insulation attached to indoor unit.

I. Indoor unit.

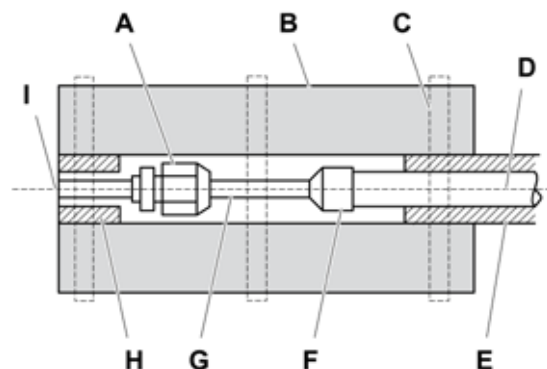

NOTE

- **A system with no moisture or oil contamination will give maximum performance and lifecycle compared to a poorly prepared system. Take particular care to ensure that all copper piping is clean and dry internally.**
- **To ensure this, blow oxygen-free nitrogen through the pipes.**

CAUTION

- Cap the end of the pipe when pipe is to be inserted through a wall hole.
- Do not put pipes on the ground directly without a cap or vinyl tape at the end of the pipe.

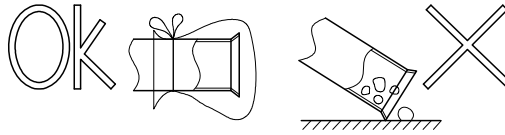

- If piping installation is not completed until next day or over a longer period of time, braze off the ends of the piping and charge with oxygen free nitrogen through a Schrader valve type access fitting to prevent moisture and particle contamination.
- Do not use insulation material that contains NH₃, as it can damage copper pipe material and become a source of future leakage.
- Insulate the unions and flare-nuts at the piping connection part completely.
- Completely insulate both refrigerant gas and liquid piping between the indoor unit and the outdoor unit to avoid a decrease of performance; if not, dew will occur on the piping surface.
- Refrigerant circuit and Water circuit must be performed and inspected by a licensed technician and must comply with all relevant European and national regulations.

3

Insulation

Attach the pipe insulation to each branch using vinyl tape. Attach also insulation to field supplied pipes in order to prevent the capacity decrease according to the ambient air conditions and dewing on the low pressure pipe surface.

1. Cap.
2. Field supplied insulation.
3. Do not make a gap.

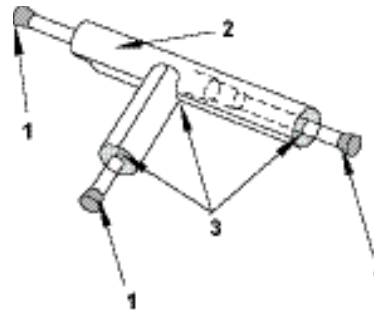

NOTE

When polyethylene foam is applied, it is recommended the usage of a wall thickness of 10 mm for the liquid piping and 15 mm to 20 mm for the gas piping.

CAUTION

- Perform the insulation work after the pipe surface temperature decreases to the room temperature, if not the insulation material may melt.
- If the ends of the piping system are open after ending the piping work, attach caps or vinyl bags securely to the ends of the piping, avoiding moisture and dust entering.

3.1.2 Three principles on refrigerant piping work

In case of using refrigerant R410A in the refrigeration cycle, the refrigeration oil should be of a synthetic type one.

In order to avoid oxidation, pay much careful attention to basic piping work control to avoid infiltration of moisture or dust during the refrigerant piping work.

Three principles	Cause of failure	Presumable failure	Preventive action
1. Dry Keep good dryness	<ul style="list-style-type: none"> Water infiltration due to insufficient protection at pipe ends Dewing inside of pipes Insufficient vacuum pumping time 	Icing inside tube at ex. valve (Water choking) + Generation of hydration and oxidation of oil ↓ Clogged strainer, etc., insulation failure and compressor failure	Pipe protection 1 Pinching 2 Taping ↓ Flushing ↓ Vacuum Drying <ul style="list-style-type: none"> One gram of water turns into gas (approx. 1000 lrs) at 1 Torr Therefore, it takes long time to vacuum-pump by a small vacuum pump
2. Clean No dust inside of pipes	<ul style="list-style-type: none"> Infiltration of dust or other through the pipe ends. Oxidation film during brazing without blowing nitrogen. Insufficient flushing by nitrogen after brazing 	Clogging of expansion valve, capillary tube and filter →Oxidation of oil →Compressor failure ↓ Insufficient cooling or heating compressor failure	Pipe Protection 1 Mounting Caps 2 Taping 3 Pinching ↓ Flushing
3. No leakage No leakage shall exist	<ul style="list-style-type: none"> Brazing failure Failed flaring work and insufficient torque of squeezing flare Insufficient torque of squeezing flanges 	Refrigerant shortage →Performance decrease →Oxidation of oil →Overheating of compressor ↓ Insufficient cooling or heating compressor failure	Careful Basic Brazing Work ↓ Basic Flaring Work ↓ Basic Flange Connecting Work ↓ Air Tight Test ↓ Holding of Vacuum

3.1.3 Suspension of refrigerant piping

Suspend the refrigerant piping at certain points and prevent the refrigerant piping from touching weak parts of the building such as walls, ceiling, etc. (If touched, abnormal noises may occur due to the vibration of the piping. Pay special attention in case of short piping length).

A. Fire-proof section treatment.

B. Indoor unit.

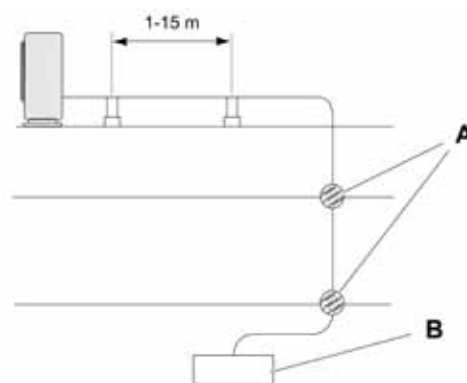

In order to fix the piping to wall or ceilings use suspension and clamping systems as shown in the following figure.



3.1.4 Brazing work

The most important work in the refrigerant piping installation work is the brazing of the pipes. If it accidentally occurs a leakage due to a careless brazing process, it will cause clogged capillary pipes or serious compressor failure.

In order to guarantee a proper brazing neck between different pipes surfaces, accurate pipe dimensions after the expansion process (see the table below):

It is important to control the clearance of the pipe fitting portion as shown below. In the case that a copper tube expansion jig is used, following dimensions should be secured.

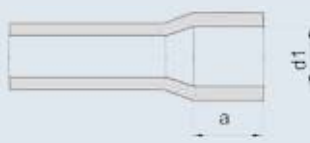

Copper pipe size		Ød1	Gap	a		Copper pipe size		Ød1	Gap	a	
Ø6.35	+0.08	Ø6.5	+0.1	0.33	6	Ø22.22	+0.09	Ø22.42	+0.1	0.39	10
	-0.08		0	0.07			-0.09		0	0.11	
Ø9.52	+0.08	Ø9.7	+0.1	0.35	8	Ø25.4	+0.12	Ø25.6	+0.1	0.42	12
	-0.08		0	0.09			-0.12		0	0.08	
Ø12.7	+0.08	Ø12.9	+0.1	0.38	8	Ø28.58	+0.12	Ø28.78	+0.1	0.42	12
	-0.08		0	0.19			-0.12		0	0.08	
Ø15.88	+0.09	Ø16.1	+0.1	0.41	8	Ø31.75	+0.12	Ø32.0	+0.1	0.47	12
	-0.09		0	0.13			-0.12		0	0.13	
Ø19.05	+0.09	Ø19.3	+0.1	0.44	10	Ø38.1	+0.12	Ø38.3	+0.1	0.52	14
	-0.09		0	0.16			-0.12		0	0.18	

A basic brazing method is shown below.

1. Pre-heat the outer tube for better flowing of the filler metal.
2. Heat inner side tube evenly.
3. Rubber plug.
4. Packless valve.
5. High pressure hose.
6. 0.03 to 0.05 MPa (0.3 to 0.5 Kg/cm² G).
7. Reducer valve: open this valve only when the gas is needed.
8. Nitrogen gas flow 0.05 m³/h or smaller.

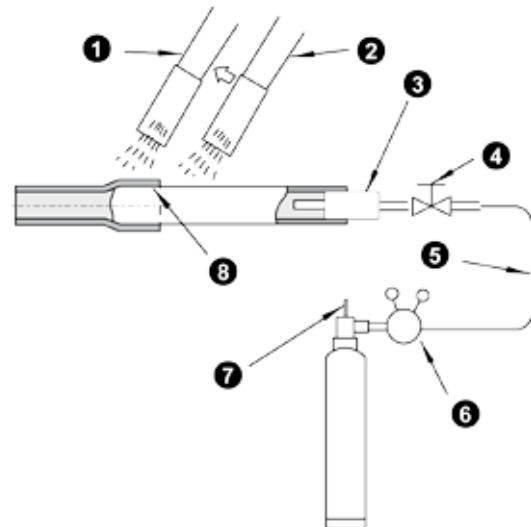

⚠ CAUTION

- Use nitrogen gas for blowing during pipe brazing. If oxygen, acetylene or fluorocarbon gas is used, it will cause an explosion or poisonous gas.
- During the brazing work, a lot of oxidation film will be generated inside of the pipes if no oxygen-free nitrogen gas is blown through the pipes. This film will be flecked off after operation and will circulate in the refrigeration cycle, resulting in clogged expansion valves, etc. This could origin problems in the compressor.
- Use a reducer valve when nitrogen gas blowing is performed during brazing. The gas pressure should be maintained within 0.03 to 0.05 MPa. If an excessively high pressure is applied to a pipe, it could origin an explosion.

3.2 Piping connection for outdoor unit

3.2.1 RAS-(2-2.5)HVNP / RAS-3HVNC

- 1 Take the piping cover away from the unit. Then fetch the pipes through the rear side and route piping according to the installation place as shown in the figure. Make holes by cutting along the guideline at the rear of the cover or punching with a driver. Remove the burr with a cutter, and place a insulation (field supplied) to protect cables and pipes.

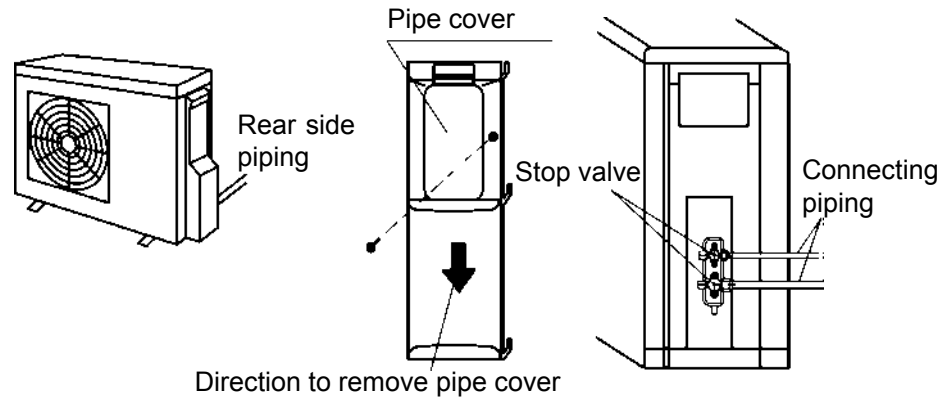

- 2 Attach the pipe cover in order to prevent rainwater from entering inside the cabinet.
- 3 Use a pipe bender for pipe bending work when connecting pipes.
- 4 Check to ensure that the stop valves are completely closed before connecting pipes.
- 5 Connect the field supplied refrigerant pipes to the indoor unit and outdoor unit. Apply the oil thinly at the seat flare nut and pipe before tightening.

The required tightening torque is as follows:

Pipe Size	Tightening Torque (Nm)
Ø 6.35 mm (1/4)	20
Ø 9.52 mm (3/8)	40
Ø 12.70 mm (1/2)	60
Ø 15.88 mm (5/8)	80
Ø 19.05 mm (3/4)	100

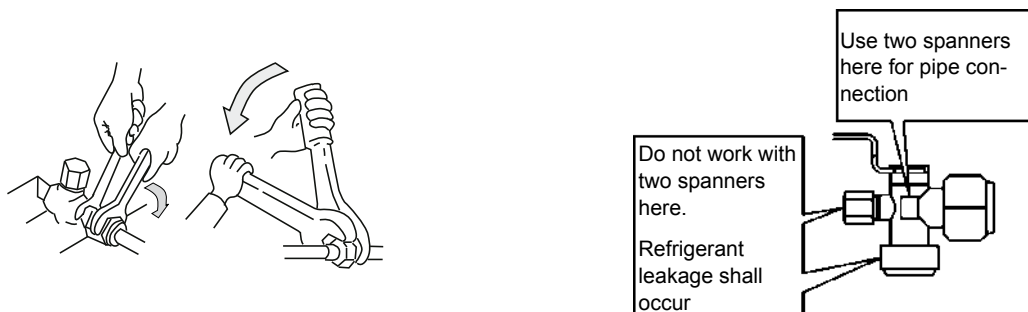

- 6 After connecting the refrigerant piping, seal the open space between knockout hole and refrigerant pipes by using insulation material.

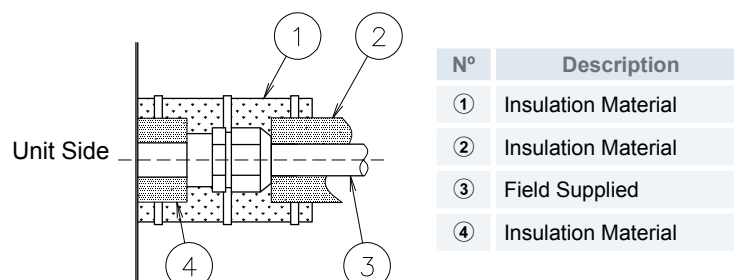

- 7 Operation of stop valve should be performed according to the *Outdoor unit stop valve* explanation.

3.2.2 RAS-3HVNPE / RAS-(4-6)H(V)N(P/C)E / RAS-(8-10)HN(P/C)E / RAS-12HN(P/C)

1 The pipes can be connected from 4 directions. Make holes in the piping cover or cabinet for taking out pipes.

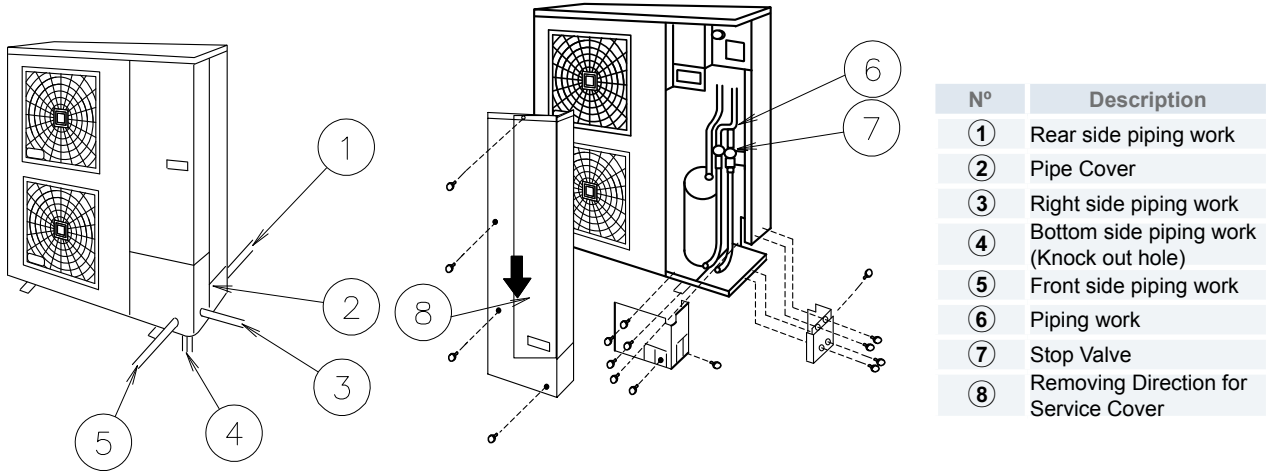

(picture as example)

Take the piping cover away from the unit and make holes by cutting along the guideline at the rear of the cover or punching with a driver. Remove the burr with a cutter and place a insulation (field supplied) to protect cables and pipes.

RAS-3HVNPE / RAS-(4-6)H(V)N(P/C)E / RAS-(8-10)HN(P/C)E

RAS-12HN(P/C)

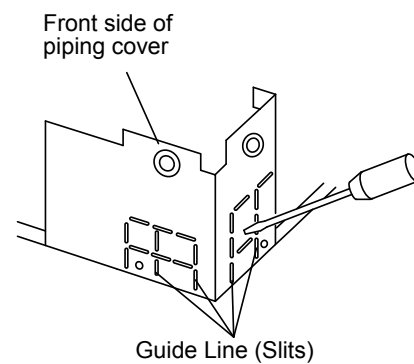
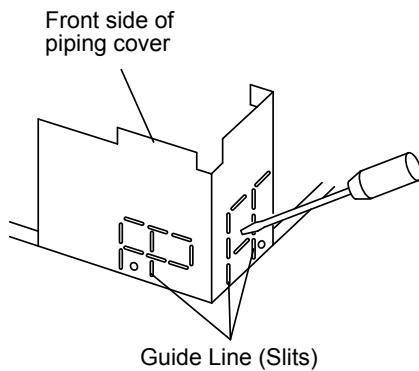

CAUTION

Notes to open/close the service cover:

- Remove the screws following the instructions to the above figure.
- Slowly press down the cover.

NOTE

Hold the cover with a hand to remove screws as the cover may fall down.

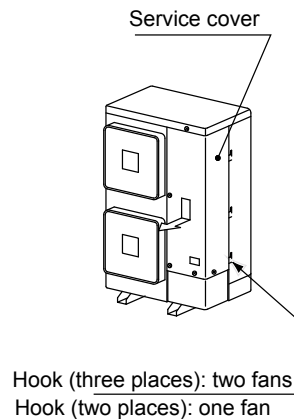

(picture as example)

◆ For the front and side piping

Select the correct knock-out size depending on whether it is for power wiring or transition wiring

RAS-3HVNP/E / RAS-(4-6)H(V)N(P/C)E / RAS-(8-10)HN(P/C)E

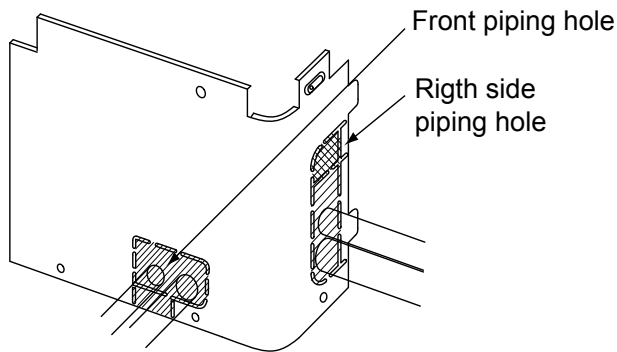

RAS-12HN(P/C)

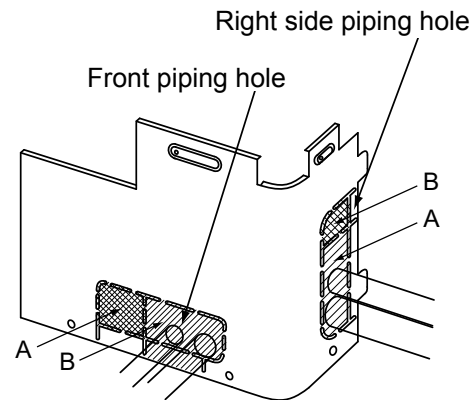

To use racking or conduit tubes, check the size and remove  part following the slit.



NOTE

Place insulation (field supplied) to protect cables and pipes from being damaged by plate edges.

◆ For the downward piping

After removing the bottom of the piping cover, perform piping and wiring works.

RAS-3HVNP/E / RAS-(4-6)H(V)N(P/C)E / RAS-(8-10)HN(P/C)E

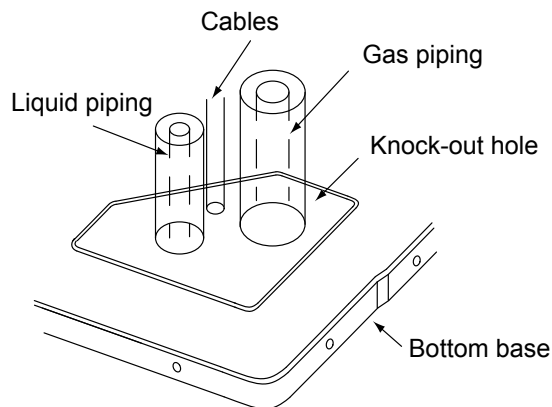

RAS-12HN(P/C)

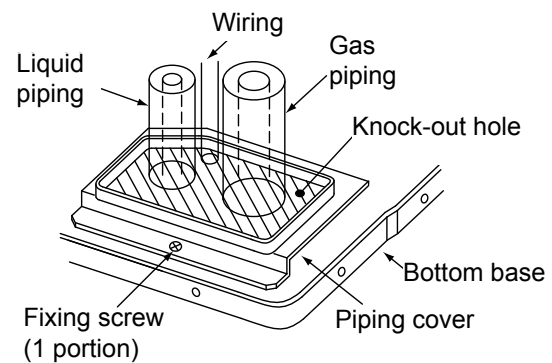

NOTE

Cables shall not contact directly to the pipes.

◆ For the rear side piping

After removing the rear-side piping cover, punch out the "A" holes along the guide line.

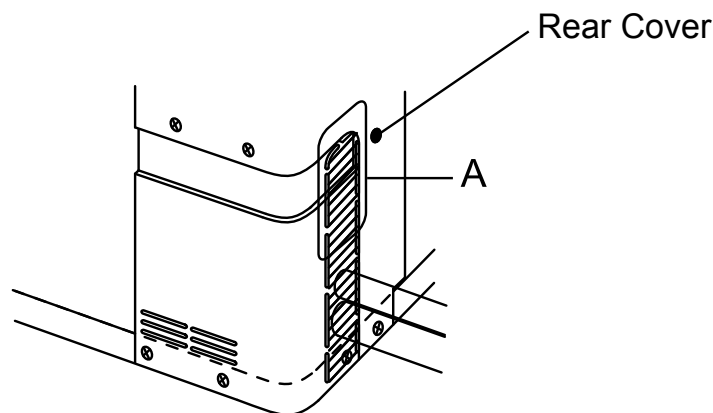

i NOTE

Remove the rear pipe cover under the rear cover and remove  part following the slit.

- 2 Mount the piping cover in order to avoid water entering into the unit. Seal the holes where pipes and wires are inserted, by using insulation (field-supplied).
- 3 If the field-supplied piping is connected with stop valves directly, it is recommended to use a tube bender.
- 4 Check to ensure that the stop valves are completely closed before connecting pipes.
- 5 Connect the field supplied refrigerant pipes to the indoor unit and outdoor unit. Apply the oil thinly at the seat flare nut and pipe before tightening.

The required tightening torque is as follows:

Pipe Size	Tightening Torque (Nm)
Ø 6.35 mm (1/4)	20
Ø 9.52 mm (3/8)	40
Ø 12.70 mm (1/2)	60
Ø 15.88 mm (5/8)	80
Ø 19.05 mm (3/4)	100

- 6 After connecting the refrigerant piping, seal the open space between knockout hole and refrigerant pipes by using insulation material.

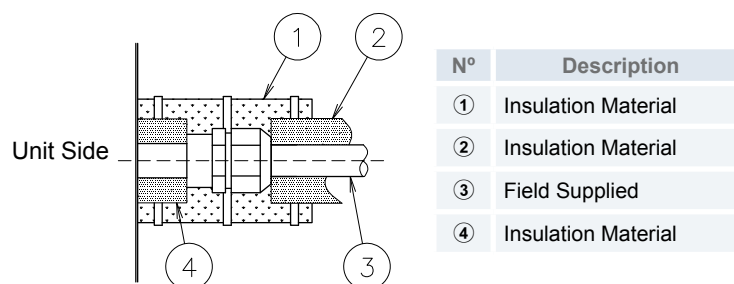

- 7 Operation of stop valve should be performed according to the [Outdoor unit stop valve](#) explanation.

3.2.3 Outdoor unit stop valve

- 1 Remove the stop valve cap before performing the air tight test after connecting the flare nut. Tighten the spindle valve in clockwise according to the following table "Tightening Torque of Stop Valves."
- 2 Tighten the flare nut according the specified torque. If the tightening torque is excessive, it may cause refrigerant leakage from the spindle part.
- 3 Perform the air tight test after the tightening work. It is more effective to perform this work after fix the flare nuts for the piping connection to the stop valves.
- 4 Use the charging hose for the check joint connection. When removing the charging hose from the check joint, a sound may be heard by a small quantity of refrigerant leak. However it is not abnormality. Do not apply excessive force to the end of opening the spindle. (Tightening Torque: < 5.0N-m)

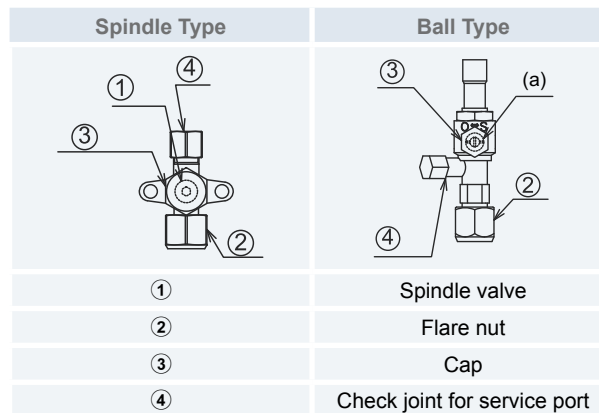

Outdoor unit	Tightening Torque (Nm)							
	①		②		③		④	
	Gas valve	Liquid valve	Gas valve	Liquid valve	Gas valve	Liquid valve	Gas valve	Liquid valve
RAS-(2-2.5)HVNP	7-9	7-9	33-42	33-42	33-42	33-42	14-18	14-18
RAS-3HVNC RAS-3HVNPE	9-11	7-9	68-82	33-42	33-42	33-42	14-18	14-18
RAS-(4-6)H(V)NCE RAS-(4-6)H(V)NPE	9-11	7-9	68-82	33-42	33-42	33-42	14-18	14-18
RAS-8HN(P/C)E	-	7-9	100-120	33-42	20-25	33-42	14-18	14-18
RAS-10HN(P/C)E	-	7-9	100-120	50-62	20-25	33-42	14-18	14-18
RAS-12HN(P/C)	-	7-9	100-120	50-62	12-14	33-42	12-14	14-18

Spindle Type

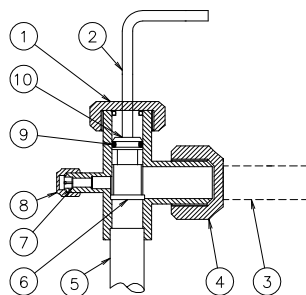

Ball Type

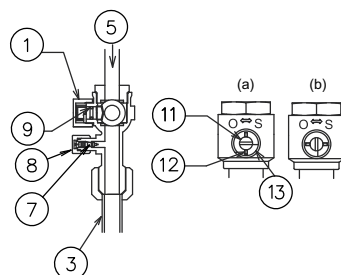

N°	Description	Remarks
①	Cap	
②	Allen wrench	Hex 4 mm *
③	Refrigerant Piping	Field Supplied
④	Flare nut	
⑤	Refrigerant Pressure	To Outdoor Unit
⑥	Seat Surface	Fully closed position
⑦	Check Joint	Only the charging those can be connected
⑧	Charge port cap	
⑨	O-Ring	Rubber
⑩	Spindle valve	Open – Counterclockwise Close – Clockwise
⑪	Shaft	
⑫	Pin	
⑬	Stopper	
(a)	Closed	This valve is opened or closed with rotating 90 degrees at the ball valve part. Rotate the shaft until the pin touches the stopper. Do not apply the extra force. Use a slotted screwdriver to control the shaft. Do not leave the ball valve partly open
(b)	Opened	

Hexagonal wrench size used for spindle valve:

(*) Size	2HP, 2.5HP	3HP, 4-6HP Standard	4-6 HP Premium, 8-12HP
Gas valve	4 mm	5 mm	-
Liquid valve	4 mm	4 mm	4 mm

Do not apply two spanners at this position. If applied, leakage will occur.

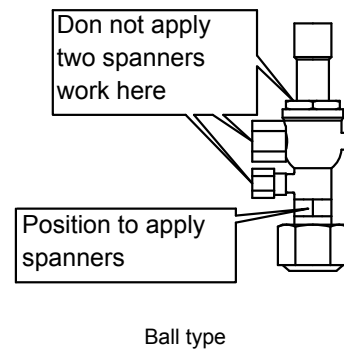
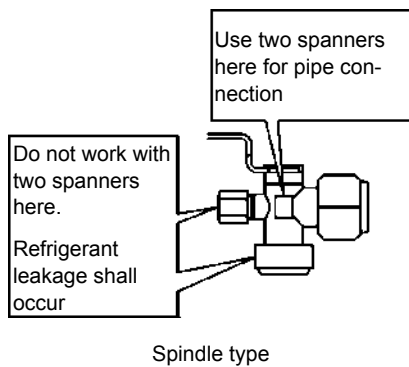
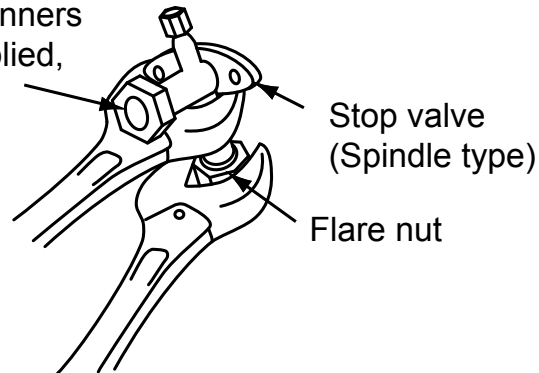

CAUTION

- **At the test run, fully open the spindle and ball stop valve.**
- **If not fully opened, the devices will be damaged.**
- **Do not attempt to turn service valve rod beyond its stop.**
- **Do not loosen the stop ring. If the stop ring is loosened, it is dangerous since the spindle will hop out.**
- **An excess or a shortage of refrigerant is the main cause of trouble to the units. Charge the correct refrigerant quantity according to the description of label at the inside of service cover.**
- **Check for refrigerant leakage in detail. If a large refrigerant leakage occurs, it will cause difficulty with breathing or harmful gases would occur if a fire was being used in the room.**

3.3 Refrigerant piping range

3.3.1 Refrigerant piping length

The refrigerant piping between the indoor unit and the outdoor unit should be designed using the following chart.

Keep the design point within the area of the chart, which is showing the applicable height difference according to piping length.

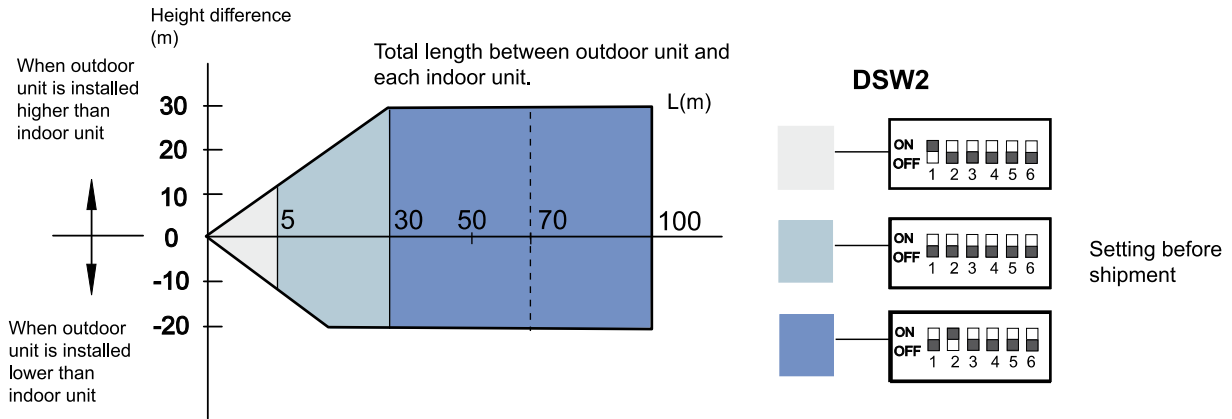

3.3.2 Piping system for header branch

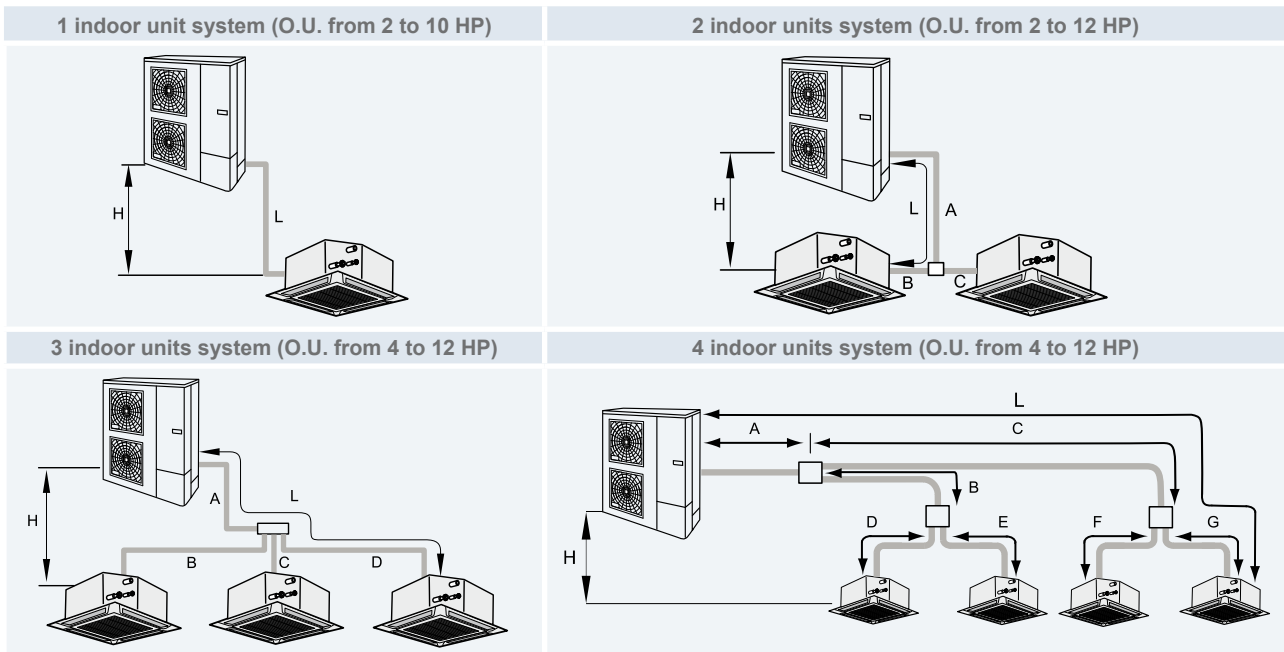

(pictures are as example)

◆ Maximum refrigerant piping length
IVX Premium series

Outdoor Unit		2HP	2.5HP	3HP	4HP	5HP	6HP	8HP	10HP	12HP	(m)	
Maximum piping length between the outdoor unit and the farthest indoor unit	Actual Length (L)	50			75			100				
	Equivalent Length (EL)	70			95			125				
Total piping length	2 units (A+B+C)	50		60	85			100	115			
	3 units (A+B+C+D)	--		60	95			100	130			
	4 units (A+B+C+D+E+F+G+)	--			95			100	145			
Maximum piping line after first branch	2 and 3 units (B, C, D)	10						15				
	4 units (B+D, B+E, C+F, C+G)	--			10			15				
Main piping length A		A > B, C, D, E, F, G										
Maximum height difference Outdoor / Indoor (H) (Outdoor Unit is Higher / Lower.)		30 / 20										
Maximum height difference Indoor / Indoor		3								10		
Maximum height difference: branch pipe/Indoor (2,3 and 4 indoor units system)		3										
branch pipe/branch pipe (4 indoor units system)		(B-C) / (B-D) / (C-D) / (C+G)-(B+E) / (C+G)-(B+D) / (C+F)-(B+E) / (C+F)-(B+D)										
		< 8										

3

IVX Standard series

(m)

Outdoor Unit		3HP	4HP	5HP	6HP	8HP	10HP	12HP
Maximum piping length between the outdoor unit and the farthest indoor unit	Actual Length (L)	50	70	75		100		
	Equivalent Length (EL)	70	90	95		125		
Total piping length	2 units (A+B+C)	60	80	85		100	115	
	3 units (A+B+C+D)	--	90	95		100	130	
	4 units (A+B+C+D+E+F+G+)	--	90	95		100	145	
Maximum piping line after first branch	2 and 3 units (B, C, D)	10				15		
	4 units (B+D, B+E, C+F, C+G)	--	10			15		
Main piping length A		A > B, C, D, E, F, G						
Maximum height difference Outdoor / Indoor (H) (Outdoor Unit is Higher / Lower.)		30 / 20						
Maximum height difference Indoor / Indoor		3						
Maximum height difference: branch pipe/Indoor (2,3 and 4 indoor units system) branch pipe/branch pipe (4 indoor units system)		3						
(B-C) / (B-D) / (C-D) / (C+G)-(B+E) / (C+G)-(B+D) / (C+F)-(B+E) / (C+F)-(B+D)		< 8						

NOTE

- *The liquid piping and the gas piping must be of the same piping length and run along the same route.*
- *Install the branch piping as much as possible near the indoor units*
- *Install Multikits at the same horizontal level.*

3.3.3 Piping system for line branch

	OU	3 HP	4 HP	5 HP	6 HP	8 HP	10 HP	12 HP
IU quantity allowed	IVX Premium	2-3	2-5	2-6		2-8		
	IVX Standard	--	2-4					

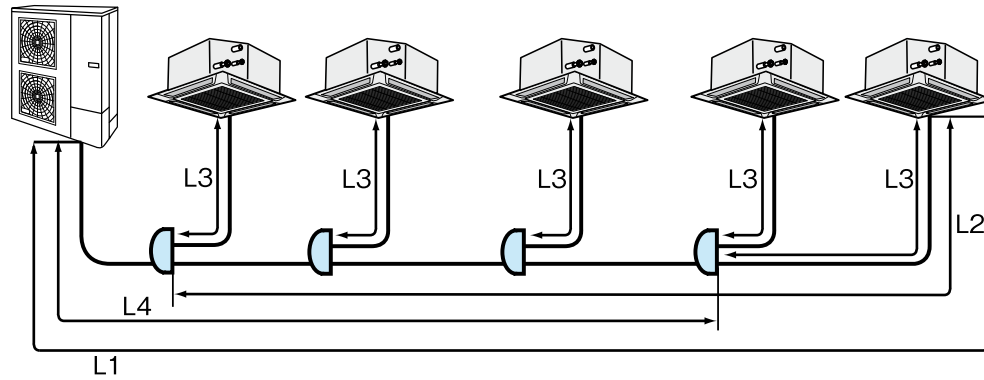

(picture is as example)

◆ Maximum refrigerant piping length (Line branch system)

IVX Premium series

Outdoor Unit		3HP	4HP	5HP	6HP	8HP	10HP	12HP
Maximum piping length between the outdoor unit and the farthest indoor unit	Actual Length (L1)	50		75			100	
	Equivalent Length (EL)	70		95			125	
Maximum piping length from first branch to each indoor unit (L2)		20		30			40	
Maximum piping length from branch to indoor unit (L3)				10			15	
Total piping length $L_4 + (L_{3_1} + L_{3_2} + L_{3_3} + \dots)$		60		95		100	145	
Maximum height difference								
Outdoor / Indoor (H) (Outdoor Unit is Higher / Lower.)		30 / 20						
Maximum height Difference Indoor / Indoor		10						
Maximum height difference:								
Branch pipe/Indoor		3						
Branch pipe/branch pipe								

IVX Standard series

Outdoor Unit		4HP	5HP	6HP	8HP	10HP	12HP	
Maximum piping length between the outdoor unit and the farthest indoor unit	Actual Length (L1)	70	75			100		
	Equivalent Length (EL)	90	95			125		
Maximum piping length from first branch to each indoor unit (L2)			20			25		
Maximum piping length from branch to indoor unit (L3)			10			15		
Total piping length $L_4 + (L_{3_1} + L_{3_2} + L_{3_3} + \dots)$		70	75		100	145		
Maximum height difference								
Outdoor / Indoor (H) (Outdoor Unit is Higher / Lower.)		30 / 20						
Maximum height Difference Indoor / Indoor		3						
Maximum height difference:								
Branch pipe/Indoor		3						
Branch pipe/branch pipe								

3.3.4 Combinations of piping size and piping length

IVX Premium series

Liquid	Ø6.35				Ø9.52					Ø12.70					Ø15.88		
	Ø9.52	Ø12.70	Ø15.88	Ø19.05	Ø12.70	Ø15.88	Ø19.05	Ø22.20	Ø25.40	Ø15.88	Ø19.05	Ø22.20	Ø25.40	Ø28.60	Ø22.20	Ø25.40	Ø28.60
Gas																	
Performance capacity	(m)																
2 HP	15 ⁽¹⁾	50	30	-	15 ⁽³⁾	15 ⁽³⁾	-	-	-	-	-	-	-	-	-	-	-
2.5 HP	-	50	30	-	20 ⁽³⁾	20 ⁽³⁾	-	-	-	-	-	-	-	-	-	-	-
3 HP	-	30 ⁽¹⁾⁽²⁾	30 ⁽²⁾	-	30 ⁽¹⁾	50	-	-	-	-	-	-	-	-	-	-	-
4 - 5 - 6 HP	-	-	5 ⁽²⁾	5 ⁽²⁾	40 ⁽¹⁾	75	50 ⁽⁴⁾	-	-	30 ⁽³⁾	30 ⁽³⁾⁽⁴⁾	-	-	-	-	-	-
8 HP	-	-	-	-	-	-	50 ⁽¹⁾⁽⁴⁾⁽⁶⁾	50 ⁽¹⁾⁽⁶⁾	70 ⁽⁵⁾⁽⁷⁾	-	50 ⁽¹⁾⁽³⁾⁽⁴⁾	50 ⁽¹⁾⁽³⁾	100	-	50 ⁽¹⁾⁽³⁾	50 ⁽³⁾	-
10 - 12 HP	-	-	-	-	-	-	-	-	-	-	-	50 ⁽¹⁾	100	50	50 ⁽¹⁾⁽³⁾	50 ⁽³⁾	50 ⁽³⁾

(1).Reducing gas pipe size will lower cooling capacity due to larger pressure loss in gas piping and narrow operation range.

(2).Reducing liquid pipe size will narrow operation range due to indoor unit relation with expansion valve capacity.

(3).Increasing liquid pipe size will require additional refrigerant charge.

(4).When using Ø19.05 gas pipe (soft-annealed), please switch ON DSW2-4# in the Outdoor Unit PCB.

(5) In case that pipe length exceeds 70m in 8 HP, please use a Ø12.7 pipe as a liquid pipe.

(6).In case of exceeding the recommended number of connected Indoor Units of 8 HP (more than 5 Units), please use a Ø12.7 pipe as a liquid

Standard

IVX Standard series

Liquid	Ø6.35				Ø9.52					Ø12.70					Ø15.88		
	Ø9.52	Ø12.70	Ø15.88	Ø19.05	Ø12.70	Ø15.88	Ø19.05	Ø22.20	Ø25.40	Ø15.88	Ø19.05	Ø22.20	Ø25.40	Ø28.60	Ø22.20	Ø25.40	Ø28.60
Gas																	
Performance capacity	(m)																
3 HP	-	30 ⁽¹⁾⁽²⁾	30 ⁽²⁾	-	30 ⁽¹⁾	50	-	-	-	-	-	-	-	-	-	-	-
4 HP	-	-	5 ⁽²⁾	5 ⁽²⁾	40 ⁽¹⁾	70	50 ⁽⁴⁾	-	-	30 ⁽³⁾	30 ⁽³⁾⁽⁴⁾	-	-	-	-	-	-
5 - 6 HP	-	-	5 ⁽²⁾	5 ⁽²⁾	40 ⁽¹⁾	75	50 ⁽⁴⁾	-	-	30 ⁽³⁾	30 ⁽³⁾⁽⁴⁾	-	-	-	-	-	-
8 HP	-	-	-	-	-	-	50 ⁽¹⁾⁽⁴⁾	50 ⁽¹⁾	70 ⁽⁵⁾	-	50 ⁽¹⁾⁽³⁾⁽⁴⁾	50 ⁽¹⁾⁽³⁾	100	-	50 ⁽¹⁾⁽³⁾	50 ⁽³⁾	-
10 - 12 HP	-	-	-	-	-	-	-	-	-	-	-	50 ⁽¹⁾	100	50	50 ⁽¹⁾⁽³⁾	50 ⁽³⁾	50 ⁽³⁾

(1).Reducing gas pipe size will lower cooling capacity due to larger pressure loss in gas piping and narrow operation range.

(2).Reducing liquid pipe size will narrow operation range due to indoor unit relation with expansion valve capacity.

(3).Increasing liquid pipe size will require additional refrigerant charge.

(4).When using Ø 19.05 gas pipe (soft-annealed), please switch ON DSW2-4# in the Outdoor Unit PCB.

(5) In case that pipe length exceeds 70m in 8 HP, please use a Ø12.7 pipe as a liquid pipe.

(6).In case of exceeding the recommended number of connected Indoor Units of 8 HP (more than 5 Units), please use a Ø12.7 pipe as a liquid

Standard

3.3.5 Refrigerant piping size and multikit/distributor selection



CAUTION

- Do not use refrigerant pipe sizes other than those indicated in this Technical Catalogue. The diameter of the refrigerant pipes depends directly on the outdoor unit capacity.
- If larger diameter gas refrigerant pipes are used, the circuit lubrication oil tends to separate from the gas carrying it. The compressor will be seriously damaged due to a lack of lubrication.
- If smaller diameter gas refrigerant pipes are used, the gas or liquid refrigerant will have serious difficulties in circulating. System performance will be affected. The compressor will run under more severe conditions than foreseen and will be damaged in a short space of time.

Select the piping connection sizes according to the following procedures

- Between outdoor unit and branch pipe: Select the same pipe connection size as the pipe size of the outdoor unit.
- Between branch pipe and indoor unit: Select the same pipe connection size as the pipe size of the indoor unit.

1 indoor unit system



Outdoor Unit HP	(mm)	
	Pipe Size (L)	
	Gas	Liquid
2 / 2.5	Ø12.70	Ø6.35
3 - 6	Ø15.88	Ø9.52
8	Ø25.40	Ø9.52
10 / 12	Ø25.40	Ø12.70

2 indoor units system



Outdoor Unit HP	(mm)		Multi-kit	
	Pipe Size (A)		IVX Premium Series	IVX Standard Series
	Gas	Liquid		
2 / 2.5	Ø12.70	Ø6.35	TW-22AN	TE-03N1
3 / 4	Ø15.88	Ø9.52	TW-52AN	3HP: TE-03N1 4HP: TE-04N1
5 / 6	Ø15.88	Ø9.52	TW-52AN	TE-56N1
8	Ø25.40	Ø9.52	TW-102AN	TE-08N
10 / 12	Ø25.40	Ø12.70	TW-102AN	TE-10N

Indoor Unit capacity	(mm)	
	Pipe Size (B, C)	
	Gas	Liquid
≤ 1.5 HP	Ø12.70	Ø6.35
1.8 / 2.0 HP	Ø15.88	Ø6.35
> 2.3 HP	Ø15.88	Ø9.52

3 indoor units system

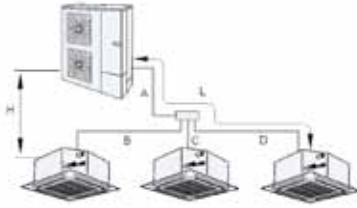

Outdoor Unit HP	(mm)		Multi-kit	
	Pipe Size (A)		IVX Premium Series	IVX Standard Series
	Gas	Liquid		
4 / 5 / 6	Ø15.88	Ø9.52	TG-53AN	TRE-46N1
8	Ø25.40	Ø9.52	TG-103AN	TRE-812N1
10 / 12	Ø25.40	Ø12.70	TG-103AN	TRE-812N1

(1) In case that pipe length (A+B or A+C or A+D) exceeds 70m in 8 HP, please use a Ø12.7 pipe as a liquid pipe.

Indoor Unit capacity	(mm)	
	Gas	Liquid
≤ 1.5 HP	Ø12.70	Ø6.35
1.8 / 2.0 HP	Ø15.88	Ø6.35
> 2.3 HP	Ø15.88	Ø9.52

4 indoor units system

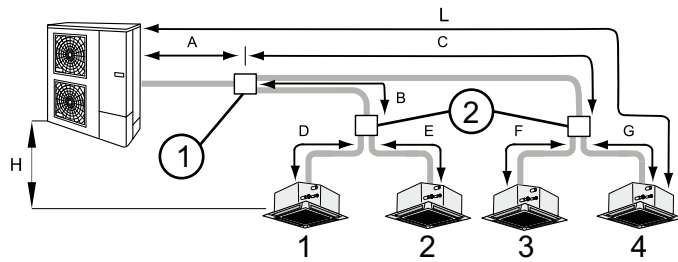

Outdoor Unit HP	Pipe Size (A)		Multi-kit (1)	
	Gas	Liquid	IVX Premium Series	IVX Standard Series
4 / 5 / 6	Ø15.88	Ø9.52	TW-52AN	4HP: TE-04N1 5/6HP: TE-56N1
8	Ø25.40	Ø9.52 ⁽¹⁾	TW-102AN	TE-08N QE-812N1 ⁽²⁾
10	Ø25.40	Ø12.70	TW-102AN	TE-10N QE-812N1 ⁽²⁾



NOTE

(1) In case that total pipe length (A+B+D or A+B+E or A+C+F or A+C+G) exceeds of 70m in 8 HP unit, please use a Ø12.7 pipe as a liquid pipe.

(2) When is used Multi-kit model QE-812N1 it is not necessary the multi.kit 2.

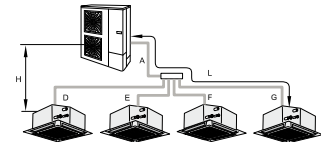

Total Indoor Unit capacity after branch pipe 1+2 or 3+4	(mm)		Multikit ②	
	Pipe Size (B,C)		IVX Premium Series	IVX Standard Series
	Gas	Liquid		
≤ 1.5 HP	Ø12.70	Ø6.35	TW-22AN	TE-03N1
from 1.8 to 2.0 HP	Ø15.88	Ø6.35	TW-52AN	TE-03N1
≥ 2.3 HP	Ø15.88	Ø9.52	TW-52AN	<4: TE-03N1 =4HP: TE-04N1 ≥ 5HP: TE-56N1

Indoor Unit capacity	Pipe Size (D,E,F,G)	
	Gas	Liquid
≤ 1.5 HP	Ø12.70	Ø6.35
1.8/2.0HP	Ø15.88	Ø6.35
≥ 2.3 HP	Ø15.88	Ø9.52

Connections including Indoor Units 8 and 10 HP are not possible

If the capacity ratio between IU group 1+2 and 3+4 is higher than 60/40% please install a line branch system or contact with your Hitachi Dealer

Line branch system

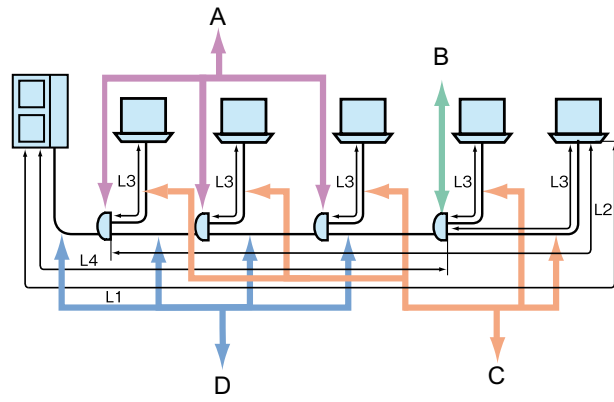

Outdoor Unit HP	(mm)		Multi-kit model A		Multi-kit model B	
	Pipe Size (D)		IVX Premium Series	IVX Standard Series	IVX Premium Series	IVX Standard Series
	Gas	Liquid				
3 / 4 / 5 / 6	Ø15.88	Ø9.52	E-102SN2	E-102SN2	E-102SN2	E-102SN2
8	Ø25.40	Ø9.52 ⁽¹⁾	E-162SN2	E-162SN2	E-102SN2	E-102SN2
10 / 12	Ø25.40	Ø12.70	E-162SN2	E-162SN2	E-102SN2	E-102SN2

(1) In case that total pipe length from the outdoor to the farthest indoor unit exceeds of 70m in 8 HP unit, please use a Ø12.7 pipe as a liquid pipe.

Indoor Unit capacity	(mm)	
	Pipe Size (C)	
	Gas	Liquid
≤ 1.5 HP	Ø12.70	Ø6.35
1.8 / 2.0 HP	Ø15.88	Ø6.35
> 2.3 HP	Ø15.88	Ø9.52

3

3.3.6 System installation



NOTE

- *Pipe connection size on outdoor units, indoor units and the multikit or distributor vary according to the system.*
- *The sizes of the indoor and outdoor units could be different. Adjust the flare adapter (accessory) to the indoor pipe connection in these cases.*

◆ Height Difference Between Indoor Units and Distributor

It is recommended to install all indoor units at the same height. When the height difference between the indoor units due to building construction is necessary, this should be less than the value indicated in the table. Install the branch pipe at the same height of indoor units or lower, but never higher.

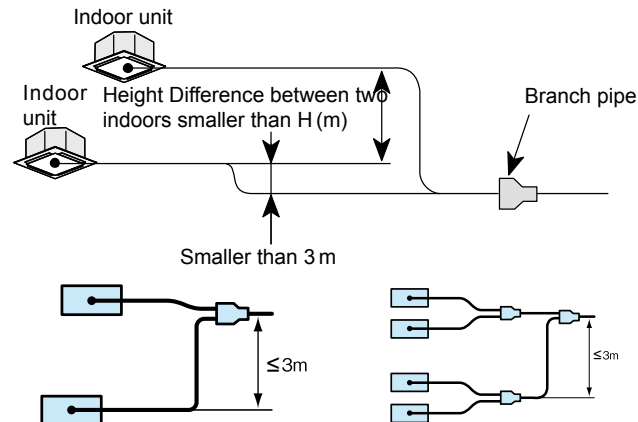

	O.U. (HP)	H (m)
Premium	2-3	3
	4-12	10
Standard	3-12	3

◆ Installing Distributor

1 Install the Distributor supplied by HITACHI on request.

A tee can not be installed instead of a branch pipe.

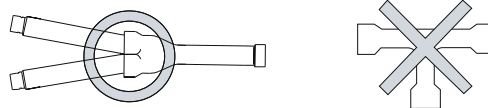

2 Installing the distributor

Fix the branch pipe horizontally to the pillar, wall or ceiling. Piping must not be fixed rigidly to the wall as thermal expansion and contraction can cause pipe fracture.

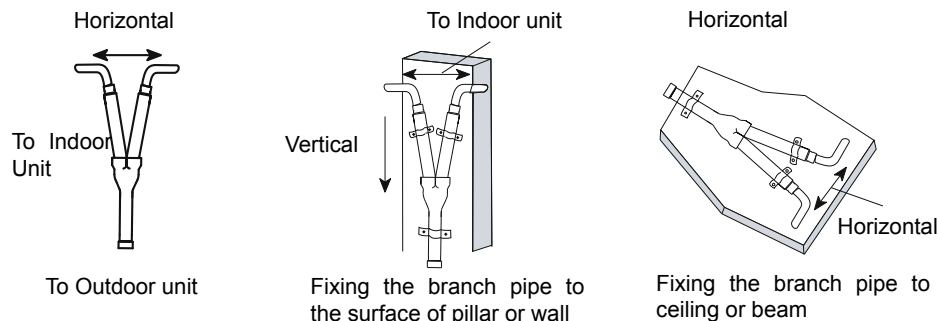

NOTE

Fix the piping from outside of insulation or inserting absorber between the pipe and a fixing metal.

3 Correct position of distributor (available also for quad installation)

- This is the correct position:

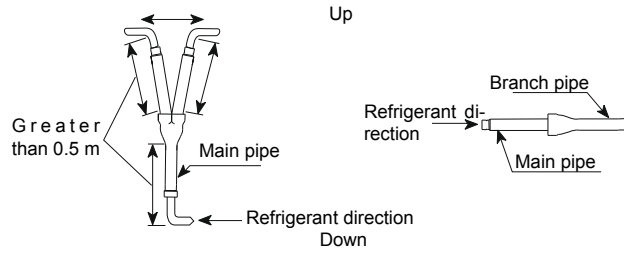

- This is wrong position.

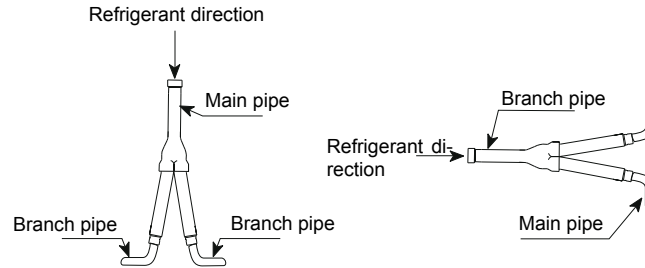

4 Correct position of Triple Branch Pipe (Standard series only).

- Install the header horizontally

Sample: Triple Branch pipe

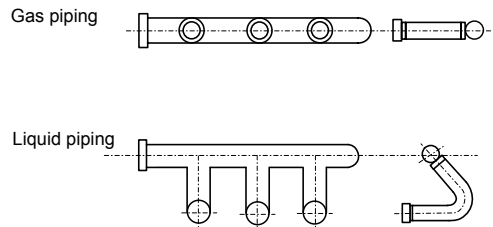

3.3.7 Connecting flare adapter

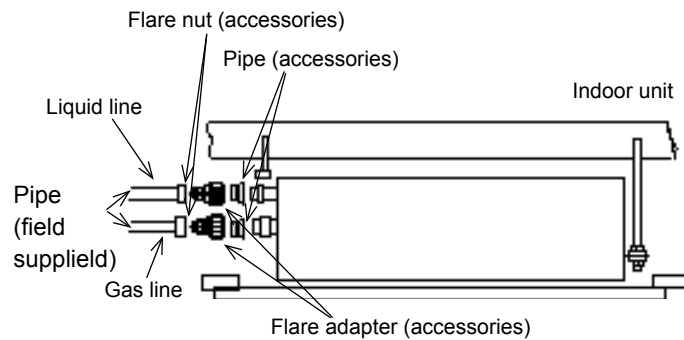

The piping sizes for indoor unit and outdoor unit are different. Attach the flare adapter (accessories) at the indoor piping union part.

Use the adequate flare adapter as follows:

Indoor unit	Flare adapter	
	Gas pipe	Liquid pipe
2.0 HP	Big size ($\varnothing 15.88 \rightarrow \varnothing 12.70$)	-
2.5 HP	Big size ($\varnothing 15.88 \rightarrow \varnothing 12.70$)	Small size ($\varnothing 9.52 \rightarrow \varnothing 6.35$)



3.4 Refrigerant charge

CAUTION

- **Do not charge OXYGEN, ACETYLENE, or other flammable and poisonous gases into the refrigerant, as an explosion could occur. It is recommended that oxygen free nitrogen be charged for these types of test cycles when performing a leakage test or an airtight test. These types of gases are extremely dangerous.**
- **Insulate the unions and flare-nuts at the piping connection part completely.**
- **Insulate the liquid piping completely to avoid a decreased performance; if not, it will cause sweating on the surface of the pipe.**
- **Charge refrigerant correctly following the procedures of the manuals. Overcharging or insufficient charging could cause a compressor failure. Insulate the unions and flare-nuts at the piping connection part completely.**
- **Check for refrigerant leakage in detail. If a large refrigerant leakage occurred, it would cause difficult breathing.**
- **If the flare nut is tightened too hard, the flare nut may crack after a long time and cause refrigerant leakage.**

Follow the next procedure to charge the R410A refrigerant inside the indoor unit:

- 1 Connect the gauge manifold using charging hoses with a nitrogen cylinder to the outdoor unit check joints of the liquid line and the gas line stop valves.
- 2 Supply power to the indoor unit and switch the DSW1-2 ON of its PCB1. Thereby the indoor unit SV1 and SV2 open to allow the vacuum and refrigerant charge operation inside the indoor unit. Very important to remind to switch the DSW1-2 OFF when finishing the whole procedure.
- 3 Check for any gas leakage at the flare nut connection by using nitrogen gas inside of the field-supplied piping to increase the pressure at 4.15 MPa.
- 4 Connect the vacuum pump to the gauge manifold and operate it for 1 to 2 hours until the pressure decreases lower than a pressure of 756 mmHg in vacuum.
- 5 Fully open the outdoor unit gas and liquid stop valves.
- 6 Operate the outdoor unit in cooling operation for more than 10 minutes to circulate the refrigerant through the whole circuit.

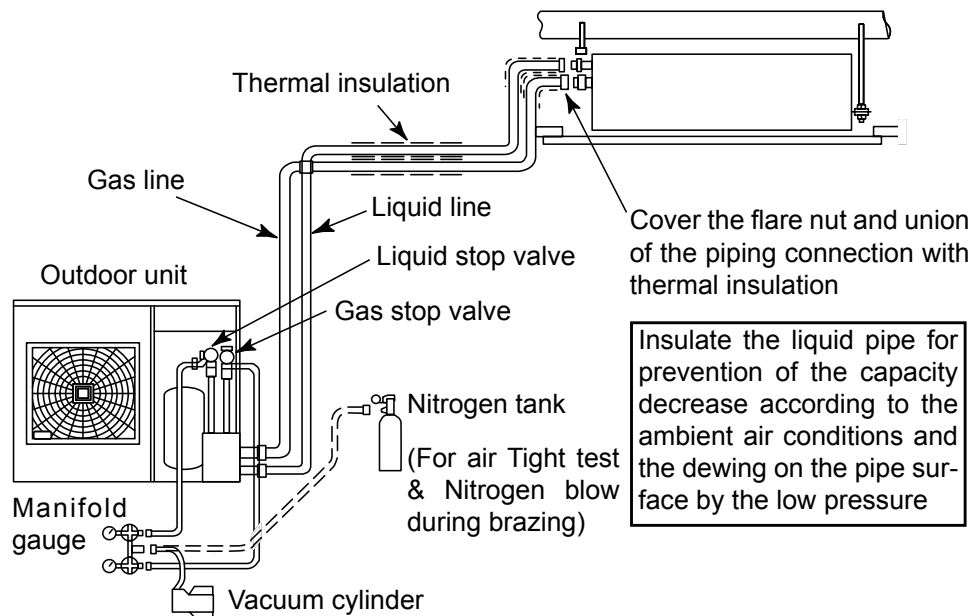

3.4.1 Caution of the pressure by check joint

When the pressure is measured, use the check joint of gas stop valve (A), and use the check joint of liquid piping (B) in the figure below.

At that time, connect the pressure gauge according to the following table because of high pressure side and low pressure side changes by operation mode.

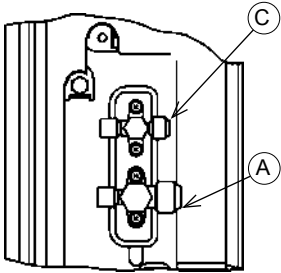
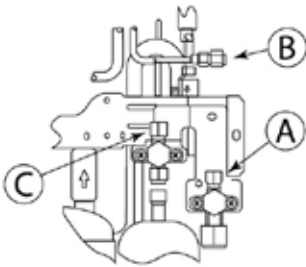
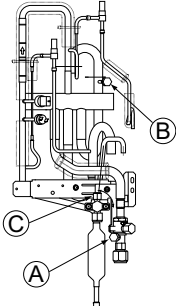
RAS-(2-2.5)HVNP RAS-3HVNC	RAS-3HVNPE RAS-(4-6)H(V)NCE	RAS-(4-6)H(V)NPE RAS-(8-10)HN(P/C)E RAS-12HN(P/C)
		

	Cooling operation	Heating operation
Check joint for gas stop valve -A-	Low pressure	High pressure
Check joint for piping -B-	High pressure	Low pressure
Check joint for liquid stop valve -C-	Exclusive for vacuum pump and refrigerant charge	



NOTE

Be careful that refrigerant and oil do not splash to the electrical parts at removing the charge hoses.

3

3.4.2 Refrigerant charge quantity

Although refrigerant has been charged into this unit, additional refrigerant charge is required according to piping length.

- 1 The additional refrigerant quantity should be determined and charged into the system according to the following procedure.
- 2 Record the additional refrigerant quantity in order to facilitate maintenance and servicing activities.

◆ Refrigerant charge before shipment (W₀ (kg))

W₀ is the outdoor unit refrigerant charge before shipment explained before, and it's shown in the following table:

IVX Premium series

Model	Refrigerant charge before shipment (W ₀ (kg))	Additional refrigerant charge (P) (g/m)	Maximum additional charge (kg)	Chargeless length (m)
RAS-2HVNP	1.6	30	1.5	30 (1)
RAS-2.5HVNP	1.6	30 (for 2 indoor units system: 24)	1.2	30 (1)
RAS-3HVNPE	2.3	40	1.2	30
RAS-4HVNPE	4.1	60	3.9	30
RAS-5HVNPE	4.2	60	3.9	30
RAS-6HVNPE	4.2	60	3.9	30
RAS-4HNPE	4.1	60	3.9	30
RAS-5HNPE	4.2	60	3.9	30
RAS-6HNPE	4.2	60	3.9	30
RAS-8HNPE	5.7	(2)	10.3	30
RAS-10HNPE	6.2	(2)	12.1	30
RAS-12HNP	6.7	(2)	12.1	30

IVX Standard series

Model	Refrigerant charge before shipment (W ₀ (kg))	Additional refrigerant charge (P) (g/m)	Maximum additional charge (kg)	Chargeless length (m)
RAS-3HVNC	1.9	40	1.2	20
RAS-4HVNCE	2.9	40	1.6	30
RAS-5HVNCE	2.9	60	2.7	30
RAS-6HVNCE	2.9	60	2.7	30
RAS-4HNCE	2.9	40	1.6	30
RAS-5HNCE	2.9	60	2.7	30
RAS-6HNCE	2.9	60	2.7	30
RAS-8HNCE	5.7	(2)	10.3	30
RAS-10HNCE	6.2	(2)	12.1	30
RAS-12HNC	6.7	(2)	12.1	30

(1) For 2 indoor units system configuration, the chargeless length is considered to be 0 m.

(2) Calculated multiplying a constant factor.

CAUTION

- *When charging refrigerant, measure the amount precisely.*
- *Overloading or underloading of refrigerant may cause compressor problems.*
- *If the actual piping length is less than 5 m consult your dealer.*

◆ Additional refrigerant charge calculation method

Calculate the additional refrigerant charge amount according to the following steps:

Step 1: Additional refrigerant charge calculation for liquid piping (W_1 (kg))

Outdoor units have been charged with refrigerant for 30m (20m for RAS-3HVNC) of actual piping length, an additional refrigerant charge is required in systems with actual piping length longer.

- For all UTOPIA units except RAS-(8-12)HN(P/C)(E)

Use the following formula:

$$W_1 = (L-30) \times P \quad (*)$$

L: Total piping length (m)

P: Additional refrigerant charge (g/m)



NOTE

(*): In case of RAS-(2-2.5)HVNP units installed in 2 indoor units system, the unit is considered to be charged with refrigerant for 0 m. In these cases, the formula for calculating the additional refrigerant charge is:

$$W_1 = (L-0) \times P$$

In case of RAS-3HVNC, the unit is charged with refrigerant for 20 m. In these cases, the formula for calculating the additional refrigerant charge is:

$$W_1 = (L-20) \times P$$

Example:

- A. 30 m.
- B. 8 m.
- C. 8 m.

- Chargeless Length ℓ : for RAS-4HVNP is 30 m according to the table before.
- Additional Correction Value P : for RAS-4HVNP, "60" according to the table above.
- Additional Charge amount W will be:

$$W = (L-\ell) \times P$$

Example: $W_1 = (46-30) \times 60 = 960$ (g)

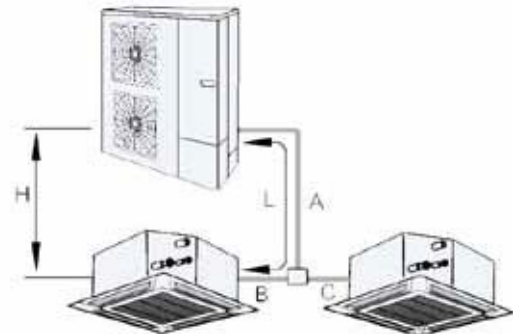

- For UTOPIA units RAS-(8-12)HN(P/C)(E)

The additional refrigerant charge for RAS-(8-12)HN(P/C)(E) units must be calculated by multiplying the total piping length of each diameter per its calculation factor according to the following table. The result is the additional refrigerant charge for liquid piping. (Fill the table with the values)

Pipe size (mm)	Additional refrigerant charge factor (kg/m)
Ø15.88	x 0.19
Ø12.7	x 0.12
Ø9.52	x 0.065
Ø6.35	x 0.065

Step 2: Additional refrigerant charge calculation for indoor unit (W_2 (kg))

When the outdoor unit is combined with indoor units RPI-(8/10)HP, it's necessary an additional refrigerant charge (W_2) = 1 kg/unit. For indoor units lower than 8 HP, an additional refrigerant charge it's not needed.

Indoor unit capacity	Additional refrigerant charge (W_2 (kg))
≥ 8 HP	1
< 8 HP	0

Step 3: Calculation of total additional refrigerant charge (W (kg))

- For all UTOPIA units except RAS-(8-12)HN(P/C)(E)

Put weight W_1 and W_2 calculated in step 1 and step 2 into the following formula:

$$W = W_1 + W_2$$

System example (W) = + = kg

- For UTOPIA units RAS-(8-12)HN(P/C)(E)

In case of RAS-(8-12)HN(P/C)(E), it must be used the following formula:

$$W = W_1 + W_2 - C$$

System example (W) = + - = kg

C: Compensation value (kg) (Refer to the following table)

Model	Compensation value (C (kg))
RAS-8HN(P/C)E	1.6
RAS-10HN(P/C)E	2.0
RAS-12HN(P/C)	2.0



CAUTION

Do not exceed the allowed maximum additional charge

Step 4: Charging work

Charge refrigerant (R410A) into the system according to the instructions in the Service Manual.

Step 5: Total refrigerant charge of the system (W_{TOT} (kg))

The total refrigerant charge of this system is calculated by the following formula:

$$W_{TOT} = W + W_0$$

System example (W_{TOT}) = + = kg

W_0 is the outdoor unit refrigerant charge before shipment explained before, and it's shown in its specific table.

Finally, record the refrigerant charge quantity in order to facilitate maintenance and servicing activities.

Total additional charge W	<input type="text"/>	kg
Total ref. charge of this system	<input type="text"/>	kg
Date of ref. charge work		
Year	<input type="text"/>	Month <input type="text"/>
		Day <input type="text"/>

◆ Setting of pipe length DSW.

DSW2 setting will be required only when the refrigerant pipe length is shorter than 5 m or longer than 30 m. Pipe length setting shall be performed as shown below.

(The ■ side in the DIP switch show the position.)

DSW2 on outdoor PCB1		
Factory setting Piping length between 5 m and ℓ(m)	Pipe Length 5 m or shorter	Pipe Length 30 m or longer

◆ Pump down refrigerant

When the refrigerant should be collected into the outdoor unit due to indoor/outdoor unit relocation, collect the refrigerant as follows:

- 1 Attach the manifold gauge to the gas stop valve and the liquid stop valve.
- 2 Turn ON the power source.
- 3 Set the DSW1-1 pin of the outdoor unit PCB at the "ON" side for cooling operation. Close the liquid stop valve and collect the refrigerant.
- 4 When the pressure at lower pressure side (gas stop valve) indicates -0.01 MPa (-100 mmHg), perform the following procedures immediately.
 - Close the gas stop valve.
 - Set the DSW1-1 pin at the "OFF" side (To stop the unit operation).
- 5 Turn OFF the power source.

CAUTION

Measure the low pressure by the pressure gauge and keep it in a measurement higher than -0.01 MPa. If the pressure is lower than -0.01 MPa, the compressor may be faulty.

3.5 Caution in case of refrigerant leakage

The installers and those responsible for drafting the specifications are obliged to comply with local safety codes and regulations in the case of refrigerant leakage.

3.5.1 Maximum permitted concentration of hydrofluorocarbon (HFC)

The refrigerant R410A, charged in the UTOPIA series system, is an incombustible and non-toxic gas. However, if leakage occurs and gas fills a room, it may cause suffocation. The maximum permissible concentration of HFC gas, R410A in air is 0.44 kg/m³, according to EN378-1.

Therefore, some effective measure must be taken to lower the R410A concentration in air below 0.44 kg/m³ to prevent suffocation in case of leakage.

3.5.2 Calculation of refrigerant concentration

- 1 Calculate the total quantity of refrigerant **R (kg)** charged in the system by connecting all the indoor units in the rooms to be air-conditioned.
- 2 Calculate the room volume **V (m³)** of each room.
- 3 Calculate the refrigerant concentration **C (kg/m³)** of the room according to the following equation:

$$C = R / V$$

R: Total quantity of refrigerant charged (kg).

V: Room volume (m³).

C: Refrigerant concentration (≤ 0.44 kg/m³ for R410A).

3.5.3 Countermeasure for refrigerant leakage

The room must have the following features to prevent suffocation in case a refrigerant leakage occurs:

- 1 Provide a shutterless opening which will allow fresh air to circulate into the room.
- 2 Provide a doorless opening of 0.15% or more size to the floor area.
- 3 There must be a ventilator fan connected to a gas leak detector, with a ventilator capacity of 0.4 m³/min or higher per Japanese refrigeration ton (= compressor displacement volume / 5.7 m³/h) of the air conditioning system using the refrigerant.

IVX Premium series

Model	Tonnes
RAS-2HVNP	0.88
RAS-2.5HVNP	1.14
RAS-3HVNPE	1.17
RAS-(4-6)H(V)NPE	2.27
RAS-8HNPE	3.16
RAS-10HNPE / RAS-12HNP	4.11

IVX Standard series

Model	Tonnes
RAS-3HVNC	1.35
RAS-4H(V)NCE	1.64
RAS-(5/6)H(V)NCE	2.27
RAS-8HNCE	3.16
RAS-10HNCE / RAS-12HNC	4.11

- 4 Pay a special attention to the place, such as a basement, etc., where refrigerant can stay, since refrigerant is heavier than air.

3.6 Piping work for compatibility with the piping of current installations where is used R22 or R407C.



NOTE

Contact your Hitachi dealer for specific support on your installation.

The new IVX Premium and IVX Standard are compatible with those installations that have been operating with R22 or R407C. This allows installing the IVX Premium/Standard Outdoor Units, which operate with R410A, without having to change piping installation.

3.6.1 Installation procedure for existing pipes



NOTE

- For systems with several indoor units, branch pipes shall be changed to Hitachi-specified model for IVX Premium and Standard (R410A).
- Existing outdoor and indoor units for R22 or R407C can not be used.

1 Recover refrigerant (R22 or R407C):

a. Compressor of the existing unit is working

Pump down. Perform refrigerant recovery operation of existing air conditioner without stopping during 30 minutes in cooling mode.

b. Compressor of the existing unit is not working

Recover refrigerant with a refrigerant recovery device.

2 Remove existing air conditioning system (Outdoor and Indoor unit).

3 For the existing pipes, proceed with one of the following operation:

a. Clean the existing piping (see section 3.6.1.1)

b. Connect renewal kit (optional accessory)(see section 3.6.1.2)

4 Connect new UTOPIA IVX Premium/Standard series

5 Vacuum process.

6 Refrigerant charge (R410A)

Follow the normal process described for determinate if it is necessary additional refrigerant charge..



CAUTION

Recovering R22 and R407C is mandatory to remove an existing air conditioner and piping. Do not vent into the atmosphere.

3.6.1.1 Conditions to use a existing pipes with cleaning process

After the piping cleaning process, follow the normal installation process as a new piping installed, considering all the restrictions and limitations. Special attention is required for control the piping thickness.

3.6.1.2 Conditions to use a existing pipes without cleaning process

A Renewal Kit (sold separately) can be used even in cases where there is a history of Compressor failure, allowing diversion to existing piping without cleaning. Thus, the burden of installation works at renewal can be reduced.

Existing pipes can be used without cleaning if the following conditions are satisfied:

1 Install the Renewal kit (mandatory).

2 Maximum piping length 50 m. (If the pipe is longer than 50m, existing pipes can be used if cleaning is performed)

3 The capacity of the new unit must be equivalent at the one installed previously.

4 No corrosion No cracks, No scratches or deformations in existing pipes.

5 Dirt insider the pipes shall not be noticeable.

6 Piping thickness, Flare Nuts, gaskets, etc. shall be compliant products.

7 Flare shall be reprocessed.

8 Piping airtight or vacuuming shall be performed precisely as new piping.

3.6.2 When existing Air-Conditioner is a product of another manufacturer

Existing pipes made by other manufacturer can also be used if the following conditions satisfied:

1 For systems with several indoor units, branch pipes shall be changed to Hitachi-specified model.

2 Please perform a pipe cleaning.

3.6.3 Permissible range for existing Air-Conditioning Pipes (Pipe length in the case of “without cleaning process”).

IVX Premium series

Liquid	Ø6.35				Ø9.52					Ø12.70				Ø15.88			
Thickness (mm)	0.8				0.8					0.8				1.0			
Gas	Ø9.52	Ø12.70	Ø15.88	Ø19.05	Ø12.70	Ø15.88	Ø19.05	Ø22.20	Ø25.40	Ø15.88	Ø19.05	Ø22.20	Ø25.40	Ø28.58	Ø22.20	Ø25.40	Ø28.58
Thickness (mm)	0.8	0.8	1.0	1.0	0.8	1.0	1.0	1.0	1.0	1.0	1.0	1.0	1.0	1.0	1.0	1.0	1.0
Material Soft-annealed	x	x	x	x	x	x	x			x	x						
Material Draw				x			x	x	x		x	x	x	x	x	x	x
Performance capacity	(m)																
2 HP	15 ⁽¹⁾	50	30	-	15 ⁽³⁾	15 ⁽³⁾	-	-	-	-	-	-	-	-	-	-	-
2.5 HP	-	50	30	-	20 ⁽³⁾	20 ⁽³⁾	-	-	-	-	-	-	-	-	-	-	-
3 HP	-	30 ⁽¹⁾⁽²⁾	30 ⁽²⁾	-	30 ⁽¹⁾	50	-	-	-	-	-	-	-	-	-	-	-
4 - 5 - 6 HP	-	-	5 ⁽²⁾	5 ⁽²⁾	40 ⁽¹⁾	50	50 ⁽⁴⁾	-	-	30 ⁽³⁾	30 ⁽³⁾⁽⁴⁾	-	-	-	-	-	-
8 HP	-	-	-	-	-	-	50 ⁽¹⁾⁽⁴⁾	50 ⁽¹⁾	50	-	50 ⁽¹⁾⁽³⁾⁽⁴⁾	50 ⁽¹⁾⁽³⁾	50 ⁽³⁾	-	50 ⁽¹⁾⁽³⁾	50 ⁽³⁾	-
10 - 12 HP	-	-	-	-	-	-	-	-	-	-	-	50 ⁽¹⁾	50	50	50 ⁽¹⁾⁽³⁾	50 ⁽³⁾	50 ⁽³⁾

(1).Reducing gas pipe size will lower cooling capacity due to larger pressure loss in gas piping and narrow operation range.

(2).Reducing liquid pipe size will narrow operation range due to indoor unit relation with expansion valve capacity.

(3).Increasing liquid pipe size will require additional refrigerant charge.

(4).When using Ø 19.05 gas pipe (soft-annealed), please switch ON DSW2-4# in the Outdoor Unit PCB.

Standard

IVX Standard series

Liquid	Ø6.35				Ø9.52					Ø12.70				Ø15.88			
Thickness (mm)	0.8				0.8					0.8				1.0			
Gas	Ø9.52	Ø12.70	Ø15.88	Ø19.05	Ø12.70	Ø15.88	Ø19.05	Ø22.20	Ø25.40	Ø15.88	Ø19.05	Ø22.20	Ø25.40	Ø28.58	Ø22.20	Ø25.40	Ø28.58
Thickness (mm)	0.8	0.8	1.0	1.0	0.8	1.0	1.0	1.0	1.0	1.0	1.0	1.0	1.0	1.0	1.0	1.0	1.0
Material Soft-annealed	x	x	x	x	x	x	x			x	x						
Material Draw				x			x	x	x		x	x	x	x	x	x	x
Performance capacity	(m)																
3 HP	-	30 ⁽¹⁾⁽²⁾	30 ⁽²⁾	-	30 ⁽¹⁾	50	-	-	-	-	-	-	-	-	-	-	-
4 HP	-	-	5 ⁽²⁾	5 ⁽²⁾	40 ⁽¹⁾	50	50 ⁽⁴⁾			30 ⁽³⁾	30 ⁽³⁾⁽⁴⁾	-	-	-	-	-	-
5 - 6 HP	-	-	5 ⁽²⁾	5 ⁽²⁾	40 ⁽¹⁾	50	50 ⁽⁴⁾			30 ⁽³⁾	30 ⁽³⁾⁽⁴⁾	-	-	-	-	-	-
8 HP	-	-	-	-	-	-	50 ⁽¹⁾⁽⁴⁾	50 ⁽¹⁾	50	-	50 ⁽¹⁾⁽³⁾⁽⁴⁾	50 ⁽¹⁾⁽³⁾	50 ⁽³⁾	-	50 ⁽¹⁾⁽³⁾	50 ⁽³⁾	-
10 - 12 HP	-	-	-	-	-	-	-	-	-	-	-	50 ⁽¹⁾	50	50	50 ⁽¹⁾⁽³⁾	50 ⁽³⁾	50 ⁽³⁾

(1).Reducing gas pipe size will lower cooling capacity due to larger pressure loss in gas piping and narrow operation range.

(2).Reducing liquid pipe size will narrow operation range due to indoor unit relation with expansion valve capacity.

(3).Increasing liquid pipe size will require additional refrigerant charge.

(4).When using Ø 19.05 gas pipe (soft-annealed), please switch ON DSW2-4# in the Outdoor Unit PCB.

Standard

3.6.4 Renewal kit selection model

Hitachi offers, as an accessory, a renewal kit:

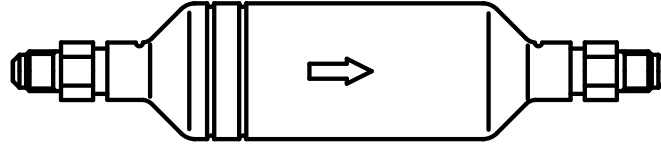

◆ Recommended renewal kit

	Renewal Kit			Renewal Kit	
IVX Premium	External Attachment to Outdoor Unit [Short Pipe (local) + Kit + Existing Piping]	Internal Attachment to Outdoor Unit [Kit + Existing Piping]	IVX Standard	External Attachment to Outdoor Unit [Short Pipe (local) + Kit + Existing Piping]	Internal Attachment to Outdoor Unit [Kit + Existing Piping]
RAS-(2/2.5)HVNP	TRF-NP63S				
RAS-3HVNPE	TRF-NP160S		RAS-(3-6)H(V)NCE	TRF-NP160S	
RAS-(4-6)H(V)NPE	(TRF-NP160S)	TRF-NP160U			
RAS-8HNPE		TRF-NP280U	RAS-8HNCE		TRF-NP280U
RAS-(10/12)HNPE		TRF-NP335U1	RAS-(10/12)HNC		TRF-NP335U1

◆ Details of renewal kit

Model Pipe	TRF-NP63S	TRF-NP160S
For liquid pipe	<p>183 130 Pipe connecting port for I.U. (Flare connection) Pipe connecting port for O.U. (Flare connection) (φ38.1)</p>	<p>189 130 Pipe connecting port for I.U. (Flare connection) Pipe connecting port for O.U. (Flare connection) (φ38.1)</p>
For gas pipe	<p>195 130 Pipe connecting port for I.U. (Flare connection) Pipe connecting port for O.U. (Flare connection) (φ38.1)</p>	<p>210 130 Pipe connecting port for I.U. (Flare connection) Pipe connecting port for O.U. (Flare connection) (φ38.1)</p>

O.U.: Outdoor Unit
I.U.: Indoor Unit

Model	TRF-NP160U
Pipe	
For liquid pipe	
For gas pipe	

O.U.: Outdoor Unit
I.U.: Indoor Unit

Model	TRF-NP280U
Pipe	
For liquid pipe	
For gas pipe	

O.U.: Outdoor Unit
I.U.: Indoor Unit

Model	TRF-NP335U1
Pipe	
For liquid pipe	
For gas pipe	

O.U. : Outdoor Unit
I.U. : Indoor Unit

◆ **Renewal kit installation (Example)**

RAS-(2/2.5)HVNP - RAS-3HVNC

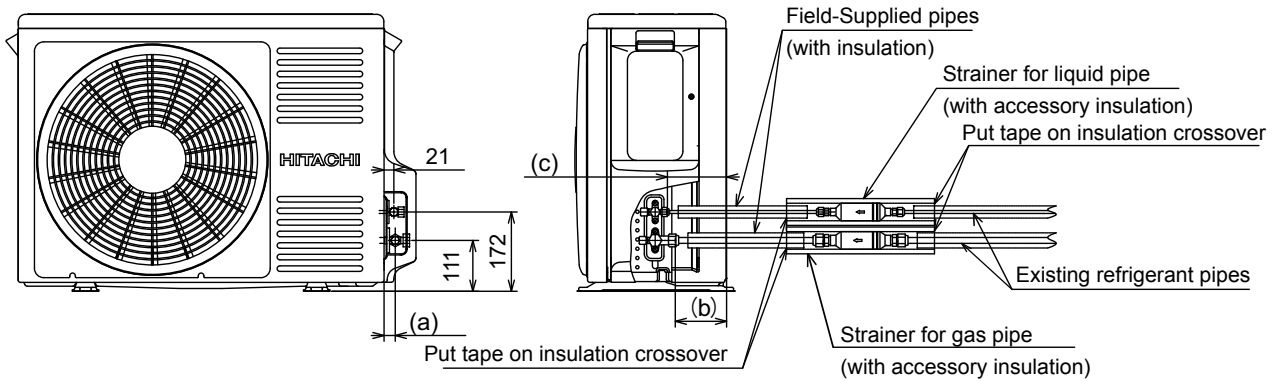

RAS-3HVNP - RAS-(4-6)H(V)NCE

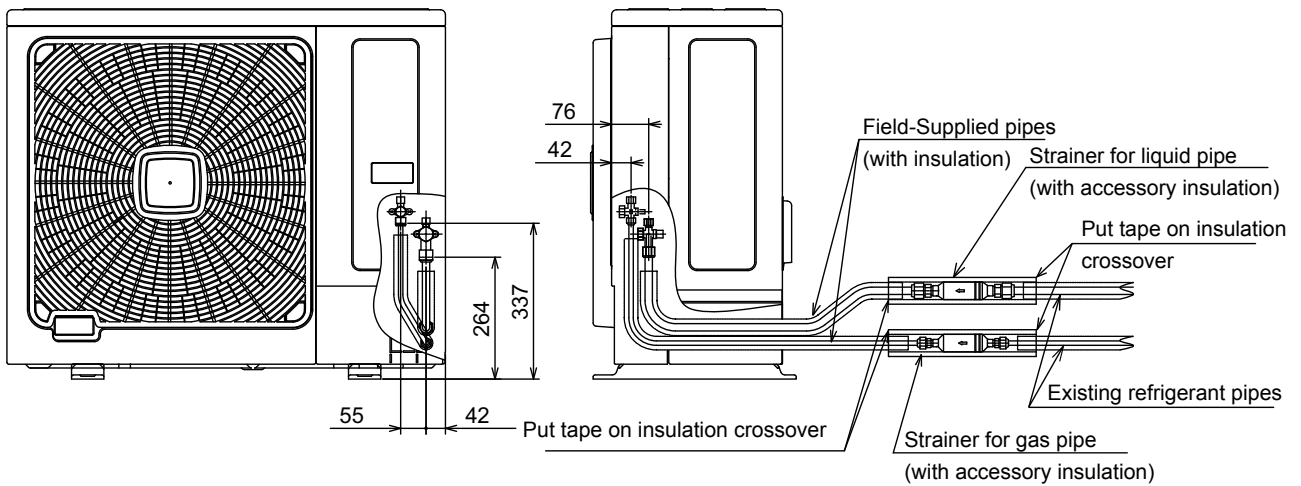

RAS-(4-6)H(V)NPE - RAS-(8/10)HN(P/C)E

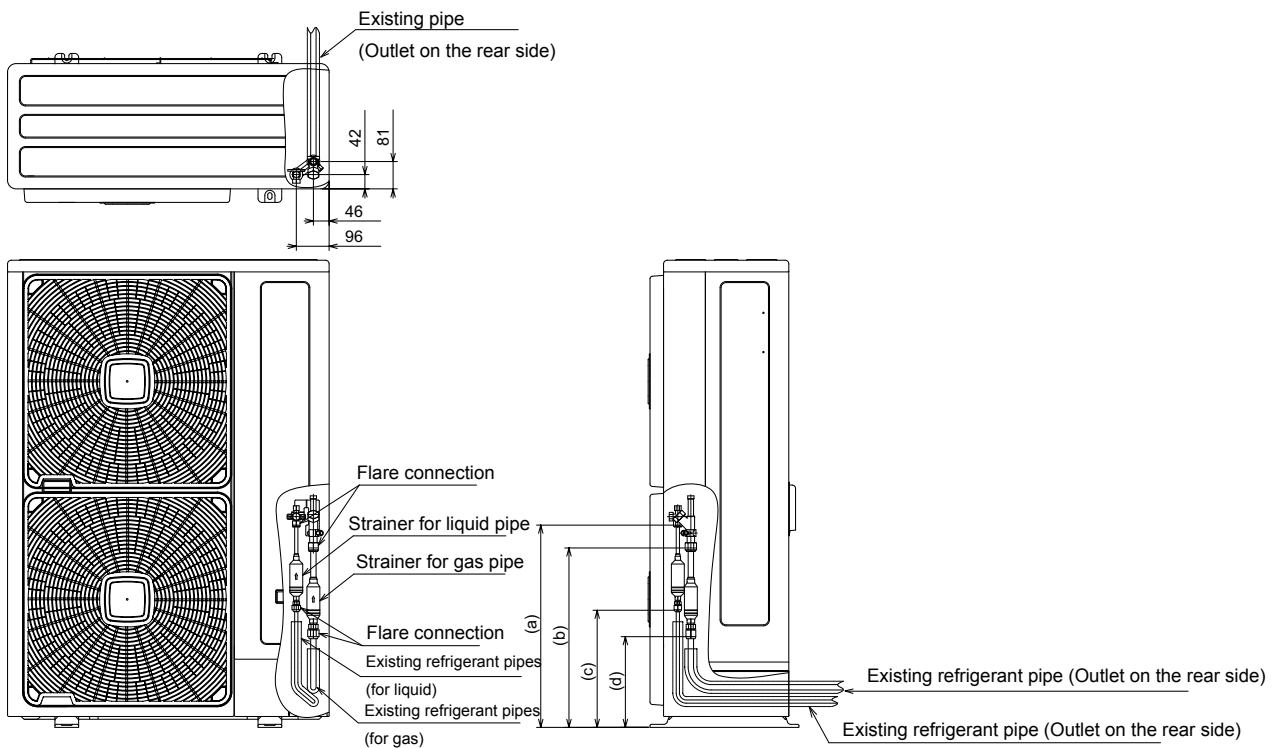

RAS-12HV(P/C)

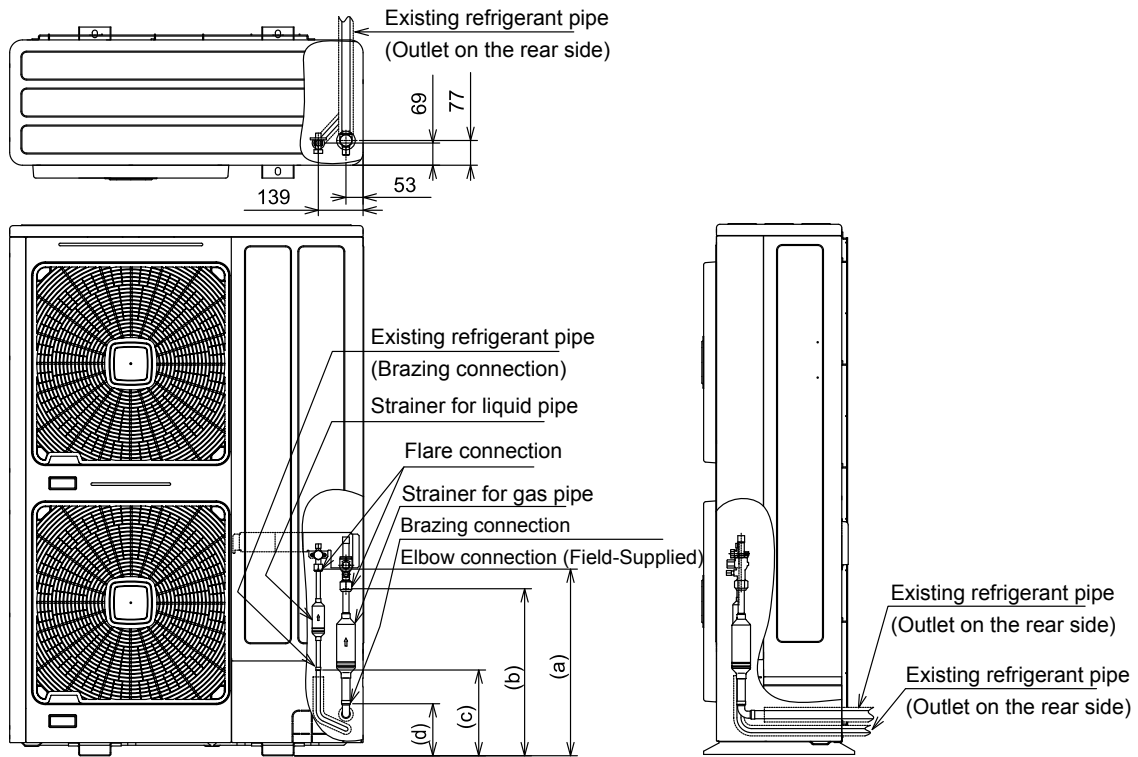

NOTE

Sizes (a) to (g) depend on the outdoor unit model

	RAS-(2/2.5)HVNP	RAS-3HVNC	RAS-(4-6)H(V)NPE	RAS-8HN(P/C)E	RAS-10HN(P/C)E	RAS-12HV(P/C)
a	22	26	581	596	578	580
b	109	103	491	497	497	521
c	129	127	329	282	264	266
d	--	--	229	137	137	161
e	--	--	46	47	--	--
f	--	--	96	98	--	--
g	--	--	81	69	--	--

3.7 Drain piping

3.7.1 Drain discharging boss

When the base of the outdoor unit is temporarily utilized as a drain receiver and the drain water in it is discharged, this drain boss is utilized to connect the drain piping.

Model	Applicable Model
DBS-12L	RAS-(2/2.5)HVNP RAS-3HVNC
DBS-26	RAS-3HVNPE RAS-(4-6)H(V)N(P/C)E RAS-(8-10)HN(P/C)E RAS-12HN(P/C)

◆ Connecting procedure

- 1 Insert the plastic cap into the drain boss up to the extruded portions.
- 2 Insert the boss into the unit base up to the extruded portions.
- 3 Size of the drain boss is:
 - For DBS-12L: 15 mm (O.D.)
 - For DBS-26: 32 mm (O.D.)
- 4 A drain pipe should be field-supplied.



NOTE

- **Do not use this drain boss set in a cold area, because the drain water may freeze.**
- **This drain boss is not sufficient to collect all the drain water. If collecting drain water is completely required, provide a drain-pan that is bigger than the unit base and install it under the unit with drainage.**

RAS-(2-2.5)HVNP / RAS-3HVNC

RAS-3HVNPE / RAS-(4-6)H(V)N(P/C)E /
RAS-(8-10)HN(P/C)E / RAS-12HN(P/C)

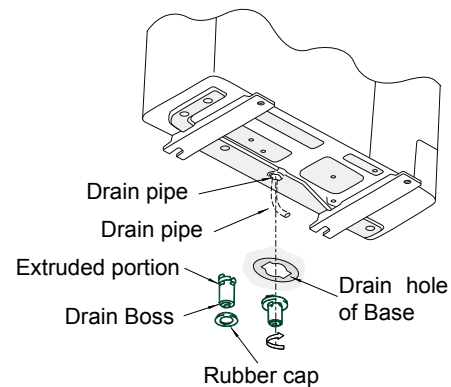
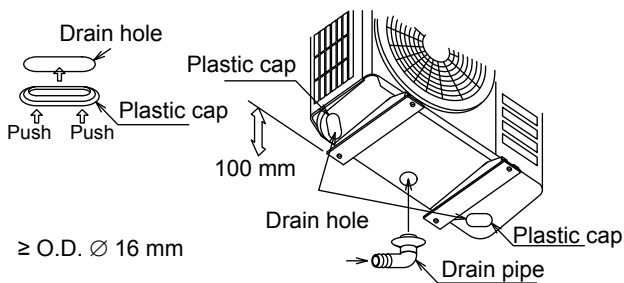

4 . Electrical wiring

Index

4.1.	General notes.....	88
4.1.1.	General check.....	88
4.2.	Electrical wiring connection for the outdoor unit.....	90
4.3.	Setting the DIP switches for the outdoor unit.....	92
4.3.1.	Quantity and position of DIP switches.....	92
4.3.2.	Function of the of DIP switches and RSW switches.....	93
4.3.3.	Jumpers.....	97
4.3.4.	LED's indication.....	97
4.4.	Common wiring.....	98
4.4.1.	Electrical wiring between outdoor and indoor unit.....	98
4.4.2.	Wire size.....	99
4.5.	H-LINK II system.....	101
4.5.1.	Features.....	101
4.5.2.	Specifications.....	101
4.5.3.	DIP Switch setting for twin, triple and quad systems.....	102
4.5.4.	Examples of the system of connection between H-LINK and H-LINK II units.....	103
4.5.5.	Examples of H-LINK II system.....	104
4.6.	System Control.....	106
4.6.1.	Individual Operation.....	106
4.6.2.	Simultaneous Operation.....	107
4.7.	Electrical wiring diagrams.....	108
4.7.1.	RAS-(2-2.5)HVNP / RAS-3HVNC (1~ 230V 50Hz).....	108
4.7.2.	RAS-3HVNPE (1~ 230V 50Hz).....	109
4.7.3.	RAS-(4-6)HVNPE (1~ 230V 50Hz).....	110
4.7.4.	RAS-(4-6)HNPE (3N~ 400V 50Hz).....	111
4.7.5.	RAS-(4-6)HVNCE (1N~ 230V 50Hz).....	112
4.7.6.	RAS-(4-6)HNCE (3N~ 400V 50Hz).....	113
4.7.7.	RAS-(8-10)HN(P/C)E (3N~ 400V 50Hz).....	114
4.7.8.	RAS-12HNP (3N~ 400V 50Hz) - Preliminary data.....	115
4.7.9.	RAS-12HNC (3N~ 400V 50Hz) - Preliminary data.....	116

4.1 General notes



CAUTION

- *Before any electrical wiring work or regular inspections, switch off the main power supply switches of the indoor and outdoor units. Wait three minutes before starting installation or maintenance work.*
- *Make sure that the indoor and outdoor are completely stopped before starting work on the electrical wiring or regular inspections.*
- *Protect cables, drain hose, electric parts, etc. from rodents and insects; otherwise these might damage unprotected components and, in the worst case, cause a fire.*
- *Wrap the accessory packing around the wires, and plug the wiring connection hole with the seal material to protect the product from any condensed water and insects.*
- *Do not allow cables to come into contact with the refrigerant pipes, metal edges, printed circuit boards (PCB) or the electric parts inside the unit; the cables may be damaged and, in the worst case, cause a fire.*
- *Tightly secure the wires with the cord clamp inside the indoor unit.*
- *Lead the wires through the knockout hole in the side cover when using conduit.*
- *Secure the cable of the remote control switch with the cord clamp inside the electrical box.*
- *Electrical wiring must comply with national and local codes. Contact your local authority in regards to standards, rules, regulations, etc.*



DANGER

- *Do not connect or adjust any wiring or connections unless the main power switch is OFF.*
- *Use an earth leakage breaker with medium sensitivity, and an activation speed of 0.1 sec or less. If this is not fitted, there is a risk of electric shock and/or fire.*
- *Install an earth leakage breaker, fuse and circuit breaker for each outdoor unit power line. Not fitting it may cause an electric shock or fire.*
- *Never connect the earth cable to the refrigerant pipes. The gas in the pipes could cause a fire.*
- *Do not connect the earth cable to the lighting arrest system. The electrical potential of earth would increase abnormally.*



NOTE

- *Fix the rubber bushes with adhesive when the outdoor unit ducts are not used.*

4.1.1 General check

- 1 Ensure that the field-supplied electrical components (mains power switches, circuit breakers, wires, connectors and wire terminals) have been properly selected according to the electrical data indicated. Make sure that they comply with national and regional electrical codes.
- 2 Following the Council Directive 2004/108/EC(89/336/EEC), relating to electromagnetic compatibility, next table indicates: Maximum permissible system impedance Z_{max} at the interface point of the user's supply, in accordance with EN61000-3-11.

MODEL	Z max (Ω)	MODEL	Z max (Ω)
RAS-2HVNP	-		
RAS-2.5HVNP	-		
RAS-3HVNPE	0.39	RAS-3HVNC	-
RAS-4HVNPE	0.27	RAS-4HVNCE	0.27
RAS-5HVNPE	0.27	RAS-5HVNCE	0.27
RAS-6HVNPE	0.27	RAS-6HVNCE	0.27
RAS-4HNPE	-	RAS-4HNCE	-
RAS-5HNPE	-	RAS-5HNCE	-
RAS-6HNPE	-	RAS-6HNCE	-
RAS-8HNPE	-	RAS-8HNCE	-
RAS-10HNPE	-	RAS-10HNCE	-
RAS-12HNP	-	RAS-12HNC	-

3 Harmonics situation of each model regarding IEC 61000-3-2 and IEC 61000-3-12 is as follows:

MODELS SITUATION REGARDING IEC 61000-3-2 and IEC 61000-3-12		MODEL
Equipment complying with IEC 61000-3-2 (*) professional use		RAS-2HVNP
		RAS-2.5HVNP
		RAS-3HVNC
		RAS-4HNPE (*)
		RAS-5HNPE (*)
		RAS-6HNPE (*)
		RAS-4HNCE (*)
		RAS-5HNCE (*)
		RAS-6HNCE (*)
Equipment complying with IEC 61000-3-12		RAS-3HVNPE
		RAS-4HVNPE
		RAS-5HVNPE
		RAS-6HVNPE
		RAS-4HVNCE
		RAS-5HVNCE
This equipment complies with IEC 61000-3-12 provided that the short-circuit power S_{sc} is greater than or equal to xx (see S_{sc} column) at the interface point between the user's supply and the public system. It is the responsibility of the installer or user of the equipment to ensure, by consultation with the distribution network operator if necessary, that the equipment is connected only to a supply with a short-circuit power S_{sc} greater than or equal to xx (see S_{sc} column)	MODEL	S_{sc} "xx" (KVA)
Installation restrictions may be applied by supply authorities in relation to harmonics	MODEL	
		RAS-8HNPE
		RAS-8HNCE
		RAS-10HNPE
		RAS-10HNCE
		RAS-12HNP
	RAS-12HNC	



DANGER

- **Never connect the earth cable to the refrigerant pipes. The gas in the pipes could cause a fire.**
 - **Do not connect the earth cable to the lighting arrest system. The electrical potential of earth would increase abnormally.**
- 5 Check to ensure that the power supply voltage is within +/-10% of the rated voltage.
 - 6 Check to ensure that power supply has an impedance low enough to warranty not reduce the starting voltage more than 85% of the rated voltage.
 - 7 Check to ensure that the ground wire is connected.
 - 8 Connect a fuse of specified capacity.

4.2 Electrical wiring connection for the outdoor unit

The correct electrical wiring connection for the outdoor unit is shown below.

- 1 Insert the power source cables L1, L2, L3 and N (for 400V/50Hz) or L1 and N (for 230V/50Hz) and the ground cable into the ring core, coiling them with two turns and fix the cables using the cable tie (accessory). As shown in next figure, do not insert the cables from different sides into the ring core.

1. N/(L2) Wire.

2. L1 Wire.

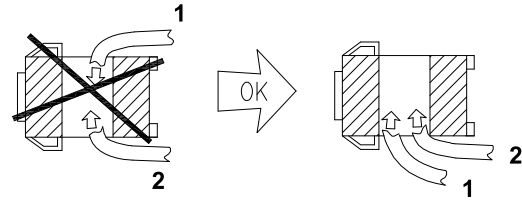

- 2 Connect the three-phase power supply source wires L1, L2, L3 and N (for 400V/50Hz) or L1 and N (for 230V/50Hz) to the terminal board. Connect the ground wire to the plate in the electrical box.

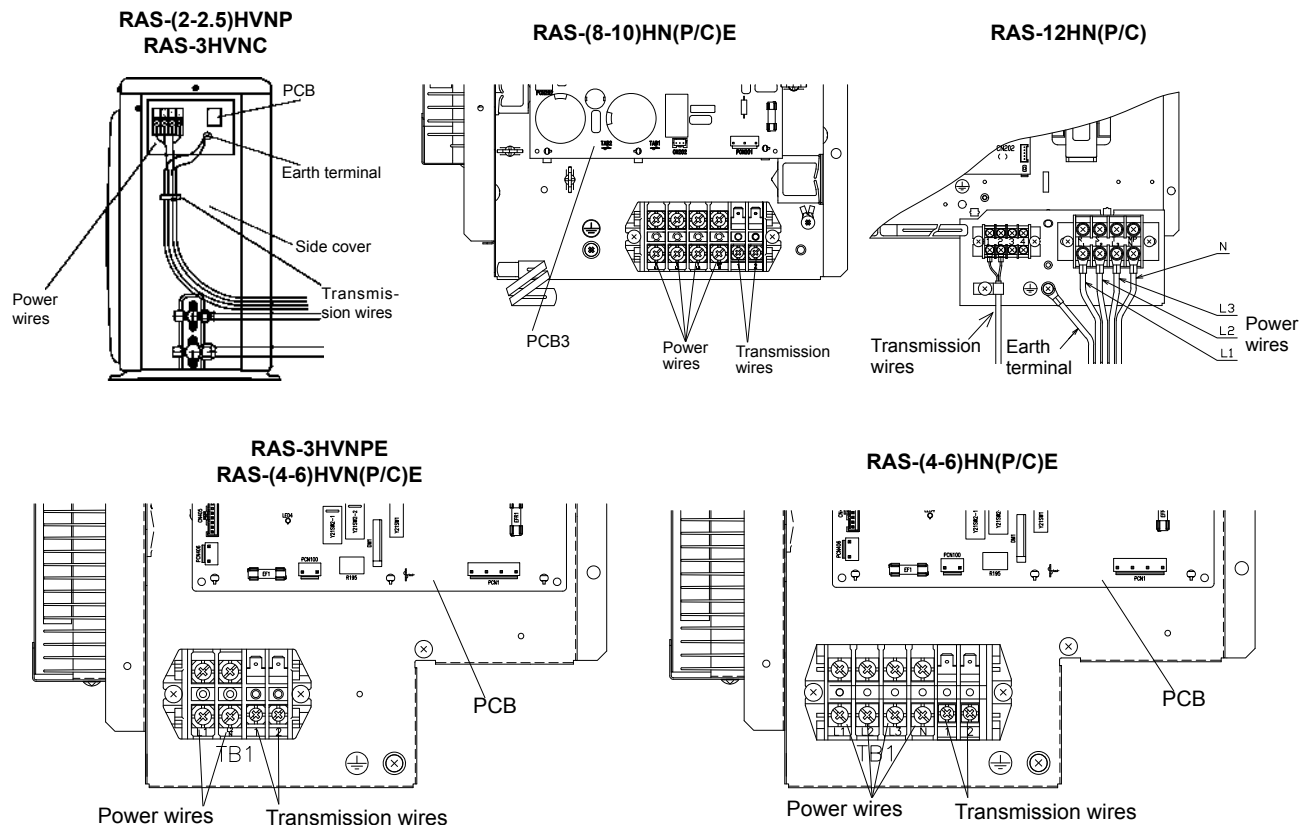

- 3 Connect the wires between the outdoor unit and the indoor unit to the terminals 1 and 2 on the terminal board.

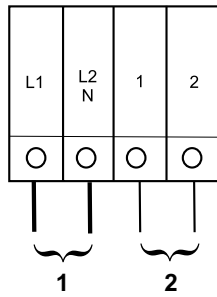

1. Power supply 1~ 230V.
2. Control cable (5V).

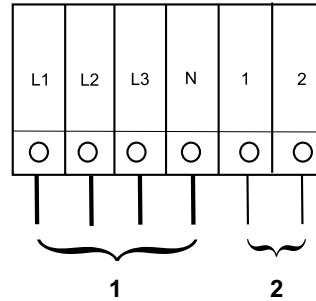

1. Power supply 3N~ 400V.
2. Control cable (5V).

- 4 Fix the cable with the clamp supplied in the Electrical Box to ensure strain relief.
5 When routing out cable, make sure that it does not obstruct mounting of the outdoor service cover.

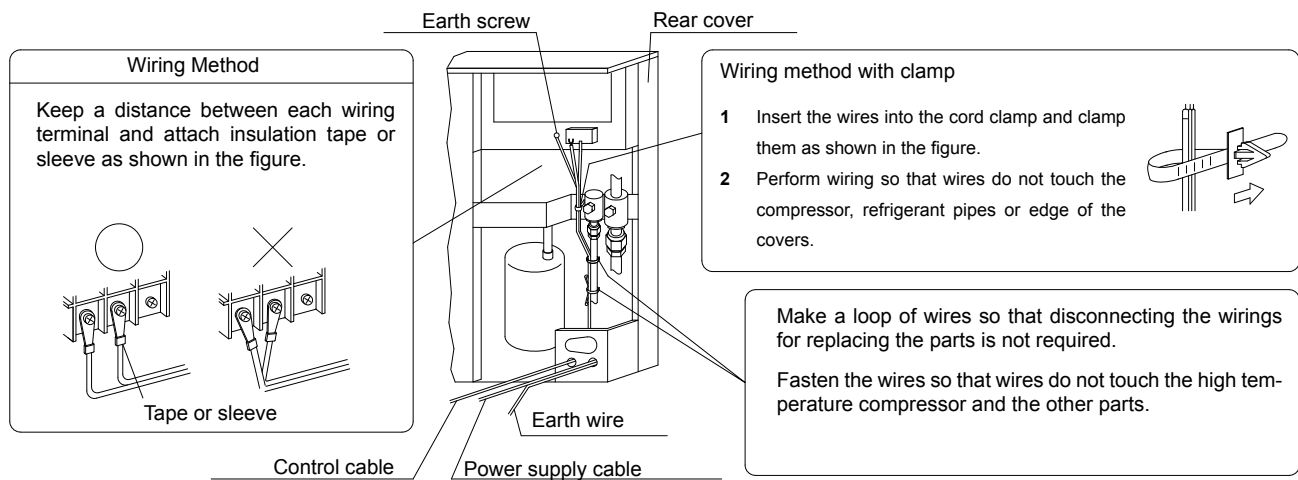

4

4.3 Setting the DIP switches for the outdoor unit

4.3.1 Quantity and position of DIP switches

The PCB in the outdoor unit is operating with DIP switches and push switches. The location is as follows:

RAS-(2/2.5)HVNP / RAS-3HVNC

PCB1

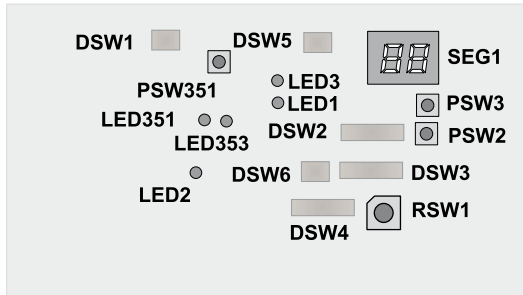

PCB2

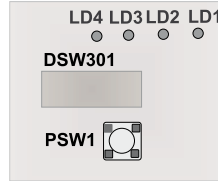

RAS-(3-12)H(V)N(P/C)(E)

PCB

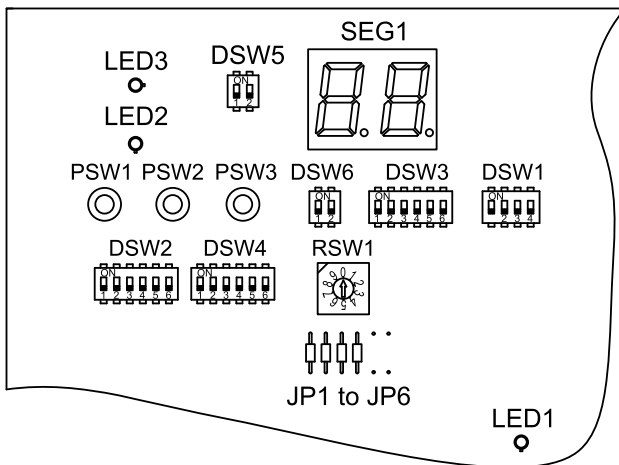

4.3.2 Function of the of DIP switches and RSW switches



NOTE

- The mark “■” indicates the position of dips switches.
- No mark “■” indicates pin position is not affecting.
- The figures show the settings before shipment or after selection.



DANGER

Before setting dips switches, first turn the power source off and then set the position of the dips switches. In case of setting the switches without turning the power source off, the contents of the setting are invalid.

DSW301 (Only RAS-(2/2.5)HVNP and RAS-3HVNC units): Test run mode

Setting before shipment	
Cooling	
Heating	
Forced stop of compressor	

DSW1 (Only RAS-(2/2.5)HVNP and RAS-3HVNC units): No setting is required

When set pin number 1 to ON, the electric current detection is cancelled. Pin number 1 should be set back to OFF after electrical work



DSW1 (RAS-(3-12)H(V)N(P/C)(E): For Test Run



Factory setting	
Cooling	
Heating	
Cooling for intermediate season	
Heating for intermediate season	
Forced stop of compressor	



NOTE



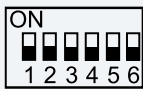
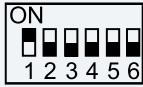
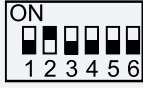
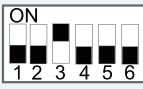
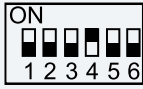







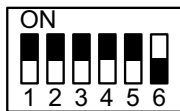

- This operation is reset once the compressor is in Thermo-ON mode.
- During the test run operation the units will operate continuously during 2 hours without Thermo-OFF and the 3-minute guard for compressor protection will be effective.

DSW2: Pipe length setting (setting is required) / Optional function setting

	<p>Setting before shipment</p> 
Pipe length setting should be performed as follows according to the on-site pipe length.	<p>Pipe length (≤5m)</p> 
	<p>Pipe length (≥30m)</p> 
	<p>Cooling only</p> 
Control to support existing pipes	
Optional function setting	
External input/output setting mode	

DSW3: Capacity setting (no setting is required)

Factory setting

RAS-2HVNP	RAS-2.5HVNP	RAS-3HVNPE	RAS-4HVN(P/C)E
			
RAS-5HVN(P/C)E	RAS-6HVN(P/C)E	RAS-4HN(P/C)E	RAS-5HN(P/C)E
			
RAS-6HN(P/C)E	RAS-8HN(P/C)E	RAS-10HN(P/C)E	RAS-12HN(P/C)
			

DSW4 / RSW1: Refrigerant cycle number setting (Setting is required)

In case of using an H-Link II net it is required to set the refrigerant cycle number.

Setting for the ten digit
(Factory setting)

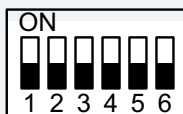

Setting position.

Set by inserting slotted screwdriver into the groove (setting for the last digit)



Rotary switch's positions (RSW1) are set by inserting a screw driver into the groove.

DSW5: End terminal resistance (No setting is required)

- Before shipment, No. 1 pin of DSW5 is set at ON.
- In case of having 2 or more outdoor units connected to the same H-link, set for the second unit the pin number 1 of DSW5 at OFF.
- If only one outdoor unit is used, no setting is required.

4

Factory setting

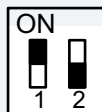

Cancellation

(Setting of end terminal resistance)

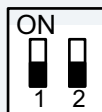
**NOTE****Setting for transmission**

It is required to set the outdoor unit number refrigerant cycle and end terminal resistance for the H-LINK.

In the same refrigerant cycle, set the same refrigerant cycle number for the outdoor unit and the indoor units.

Example in case of setting before cycle number 25

DSW4: Turn ON pin number 2



RSW1: set dial number 5

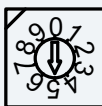

In case that the outdoor units quantity in the same H-LINK II is 2 or more, set in the DSW5 the pin number 1 OFF side from the second refrigerant group outdoor units. If only one outdoor unit is used (in the same H-Link II system), no setting is required.

Turn OFF DSW5 No.1 pin for cancel of end terminal resistance setting.

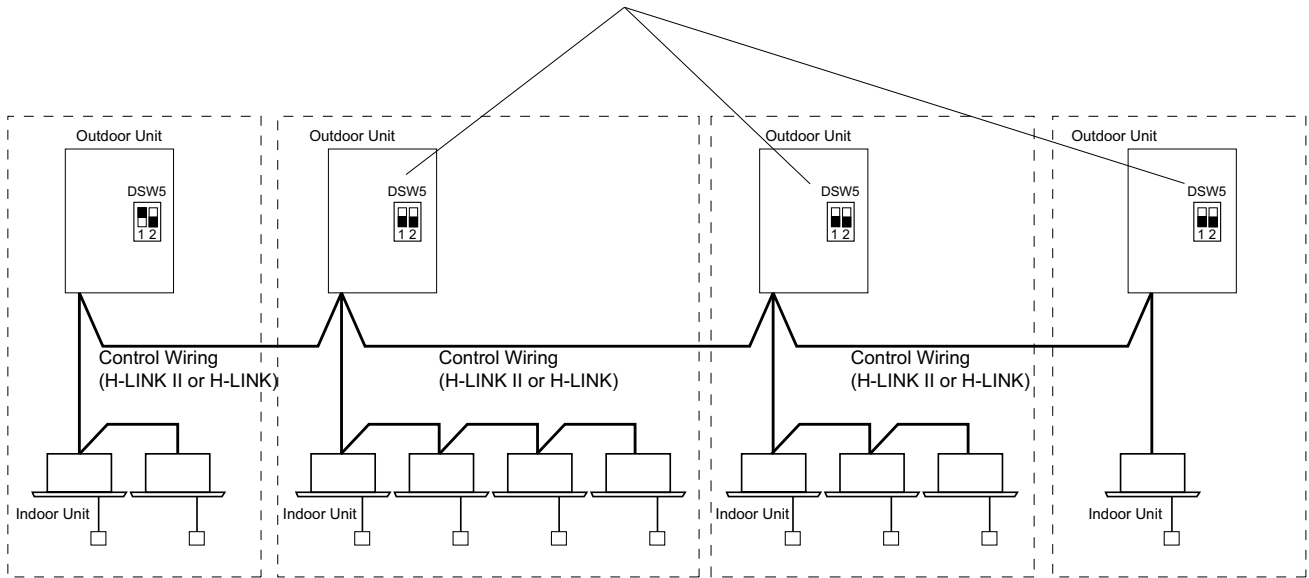

DSW6: Setting of multiple indoor units operation (setting is required)

Optional function setting	For individual operation (factory setting)
	For simultaneous operation
	<p>Set pin number 1 at OFF for simultaneous operation</p>

Wiring Example

Basic Combinations
(In the case of Twin Combination)

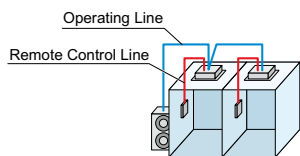

Individual Control
Running ON/OFF Individually
Thermo-ON/OFF Individually

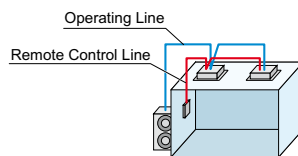

Individual Control
Running ON/OFF Simultaneously
Thermo-ON/OFF Individually

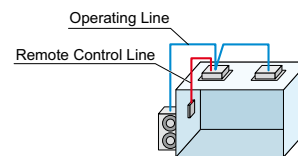

Simultaneous Control
Running ON/OFF Simultaneously
Thermo-ON/OFF Simultaneously



4.3.3 Jumpers

Jumper lead setting (JP1~6)

Setting before shipment:

System	JP1	JP2	JP3	JP4	JP5	JP6
Single phase (1~)	0	1	1	1	0	0
Three-phase (3N~)	1	1	0	1	0	0



- **0: Open**
- **1: Short circuit**

The function selection using the jumper lead setting is shown in the tables below:

RAS-(2-2.5)HVNP / RAS-3HVNC		
Setting	Function	Details
JP1	Not used	—
JP2	Not used	—
JP3	Not used	—
JP4	Fixing for Cooling Only	When JP4 is set to "open", operation mode is fixed for cooling. Thermo-ON is available only by "COOL" or "DRY" mode at indoor unit.
JP5	Selfdiagnosis	For function test of the outdoor unit control PCB.
JP6	Phase detection release	Phase detection abnormally not detected. Release of the Momentary Power Failure between S and T phases

RAS-(3-12)H(V)N(P/C)(E)		
Setting	Function	Details
JP1	220V power source voltage	When JP1 is set to "open", changes value of current protection, etc., to 220V power source voltage.
JP2	415V power source voltage	When JP2 is set to "open", changes value of current protection, etc., to 415V power source voltage. However, in single phase units it becomes 200V power source voltage.
JP3	380V power source voltage	When JP3 is set to "open", changes value of current protection, etc., to 380V power source voltage. However, in single phase units it becomes 200V power source voltage.
JP4	Fixing for Cooling Only	When JP4 is set to "open", operation mode is fixed for cooling. Thermo-ON is available only by "COOL" or "DRY" mode at indoor unit.
JP5	Selfdiagnosis	For function test of the outdoor unit control PCB. Factory default setting is open. When power ON in short condition it enters selfdiagnosis.
JP6	Phase detection release	Phase detection abnormally not detected. When short, doesn't affect phase detection.

4.3.4 LED's indication

LED Indication		
LED1	Red	This LED indicates the transmission status between the indoor unit and the RCS
LED2	Yellow	This LED indicates the transmission status between the indoor unit and the outdoor unit
LED3	Green	Power source for the PCB

4.4 Common wiring

4.4.1 Electrical wiring between outdoor and indoor unit

- Connect the electrical wires between the indoor unit and the outdoor unit as show in the figure.
- When installing the electrical wiring, follow local codes and regulations.
- The refrigerant piping and the control wiring are connected to the units in the same refrigerant cycle.
- Use twist pair wire (more than 0.75 mm²) for operation wiring between the outdoor unit and indoor unit, and operation wiring between indoor unit and indoor unit.
- Use a 2-core wire for the operating line (do not use wire with more than 3 cores).
- Use shielded wires for intermediate wiring to protect the units from noise interference at lengths of less than 300 m. The size must comply with local code.
- Open a hole near the connection hole of power source wiring when multiple outdoor units are connected from a single power source line.
- The recommended breaker sizes are detailed in the Wire size section.
- In the case that a conduit tube for field-wiring is not used, fix rubber bushes with adhesive on the panel.
- All field wiring and equipment must comply with local and international codes.
- H-LINK twist pair shielded cable must be grounded in the outdoor unit side.



CAUTION

Take care with the connection of the operating line. Incorrect connection may cause a failure of the PCB.

Power source from the outdoor unit to the indoor unit

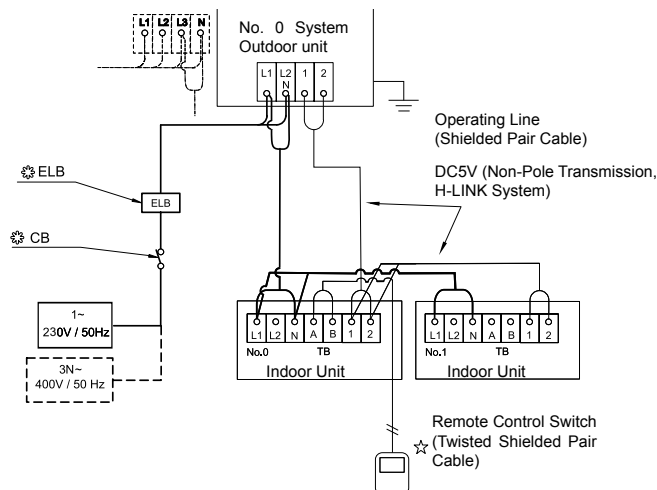

Independent power source of outdoor unit and indoor unit

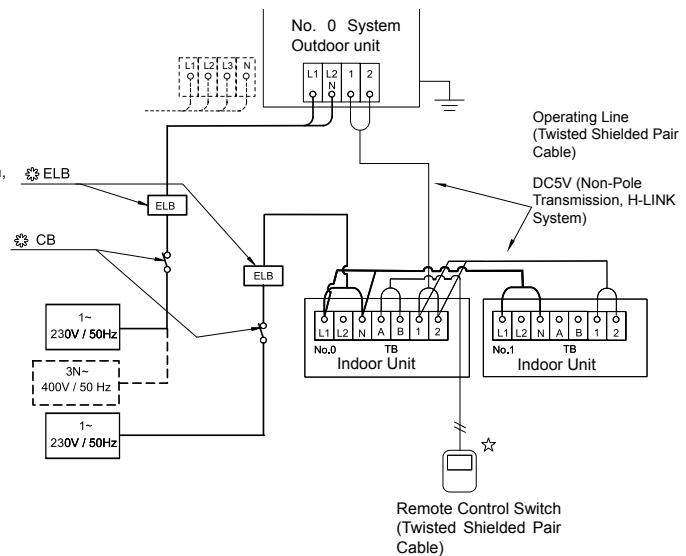

- TB Terminal board
 CB Circuit Breaker
 ELB Earthleakage Breaker
 — Field Wiring
 Field supplied
 Optional Accessory

4.4.2 Wire size

◆ Connection wiring

Recommended minimum sizes for field provided wires:

Model	Power supply	Power source cable size	Transmitting cable size
		EN60 335-1	EN60 335-1
All Indoor Units	1~ 230V 50HZ	0.75 mm ²	0.75 mm ²
IVX Premium Series			
RAS-2HVNP	1~ 230V 50HZ	2.5 mm ²	0.75 mm ²
RAS-2.5HVNP		4.0 mm ²	
RAS-3HVNP		6.0 mm ²	
RAS-4HVNP			
RAS-5HVNP			
RAS-6HVNP			
RAS-4HNPE	3N~ 400V 50Hz	2.5 mm ²	
RAS-5HNPE		6.0 mm ²	
RAS-6HNPE			
RAS-8HNPE			
RAS-10HNPE			
RAS-12HNP			
IVX Standard Series			
RAS-3HVNC	1~ 230V 50HZ	4.0 mm ²	0.75 mm ²
RAS-4HVNCE		6.0 mm ²	
RAS-5HVNCE			
RAS-6HVNCE			
RAS-4HNCE	3N~ 400V 50Hz	4.0 mm ²	
RAS-5HNCE			
RAS-6HNCE			
RAS-8HNCE		6.0 mm ²	
RAS-10HNCE			
RAS-12HNC			

4



NOTE

- Follow local codes and regulations when selecting field wires, Circuit breakers and Earth Leakage breakers
- Use the wires which are not lighter than the ordinary polychloroprene sheathed flexible cord (code designation H05RN-F)

◆ Main switch protection

Select the main switches in according to the next table:

Model	Power supply	Max. current (A)	CB (A)	ELB (no. poles/A/mA)
All Indoor Units	1~ 230V 50Hz	5.0	6	2/40/30

ELB: Earth switch; CB: Circuit breaker

IVX Premium series

Outdoor unit	MC (A)	CB (A)	ELB
RAS-2HVNP	12.0	16	2/40/30
RAS-2.5HVNP	14.0	20	
RAS-3HVNPE	19.0	20	
RAS-4HVNPE	28.0	32	
RAS-5HVNPE	28.0	32	
RAS-6HVNPE	28.0	32	
RAS-4HNPE	11.5	15	4/40/30
RAS-5HNPE	11.5	15	
RAS-6HNPE	13.5	15	
RAS-8HNPE	24.0	30	
RAS-10HNPE	24.0	30	
RAS-12HNP	24.3	30	

IVX Standard series

Outdoor unit	MC (A)	CB (A)	ELB
RAS-3HVNC	16.0	20	2/40/30
RAS-4HVNCE	28.0	32	
RAS-5HVNCE	28.0	32	
RAS-6HVNCE	28.0	32	
RAS-4HNCE	15.0	20	4/40/30
RAS-5HNCE	15.0	20	
RAS-6HNCE	15.0	20	
RAS-8HNCE	24.0	30	
RAS-10HNCE	24.0	30	
RAS-12HNC	24.3	30	

4.5 H-LINK II system

The H-LINK II is the wiring connection system between units.

The H-LINK II wiring system only needs:

- Two transmission wires connecting each indoor and outdoor unit for a total of 64 refrigerant cycles.
- Connection wiring for all indoor and outdoor units in series.



CAUTION

The H-LINK II system cannot be applied to the models with the old cycle, nor to units with an old transmission.

4.5.1 Features

- The total wiring length is considerably reduced compared to traditional connections.
- Only one connection is required for the wiring between the indoor and outdoor units.
- The wiring connection of the complementary central control devices is easy.



NOTE

- **CSNET WEB** is a centralized control system which allows the installation to be controlled remotely. It can be connected at any point of the local corporate network, or even via the Internet.

4.5.2 Specifications

A: outdoor unit.

B: indoor unit.

C: refrigerant cycle.

D: transmission cables.

E: refrigerant piping.

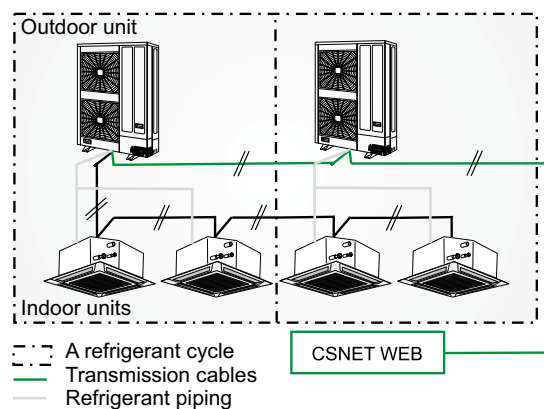

Cable features

- Transmission cable: 2-wire.
- Polarity of transmission cable: non-polar wire.
- Maximum number of indoor units that can be connected: 4 units per cycle and 160 units per H-LINK II system.
- Maximum wiring length: total 1000 m (including CSNET WEB).
- It is possible to increase the maximum wiring length up to 5000 m by using up to four PSC-5HR units.
- Recommended cable: shielded twisted pair cable, over 0.75 mm² (Equivalent to KPEV-S).
- Voltage: 5V DC.



CAUTION

For the H-LINK II system it must be used twisted shielded pair cable or shielded pair cable.

4.5.3 DIP Switch setting for twin, triple and quad systems

Dip switch of indoor PCB and outdoor H-LINK II

The DIP switches of all the indoor and outdoor units have to be set and the impedance of the transmission circuit adapted.

- Example of the setting of the DIP switches.

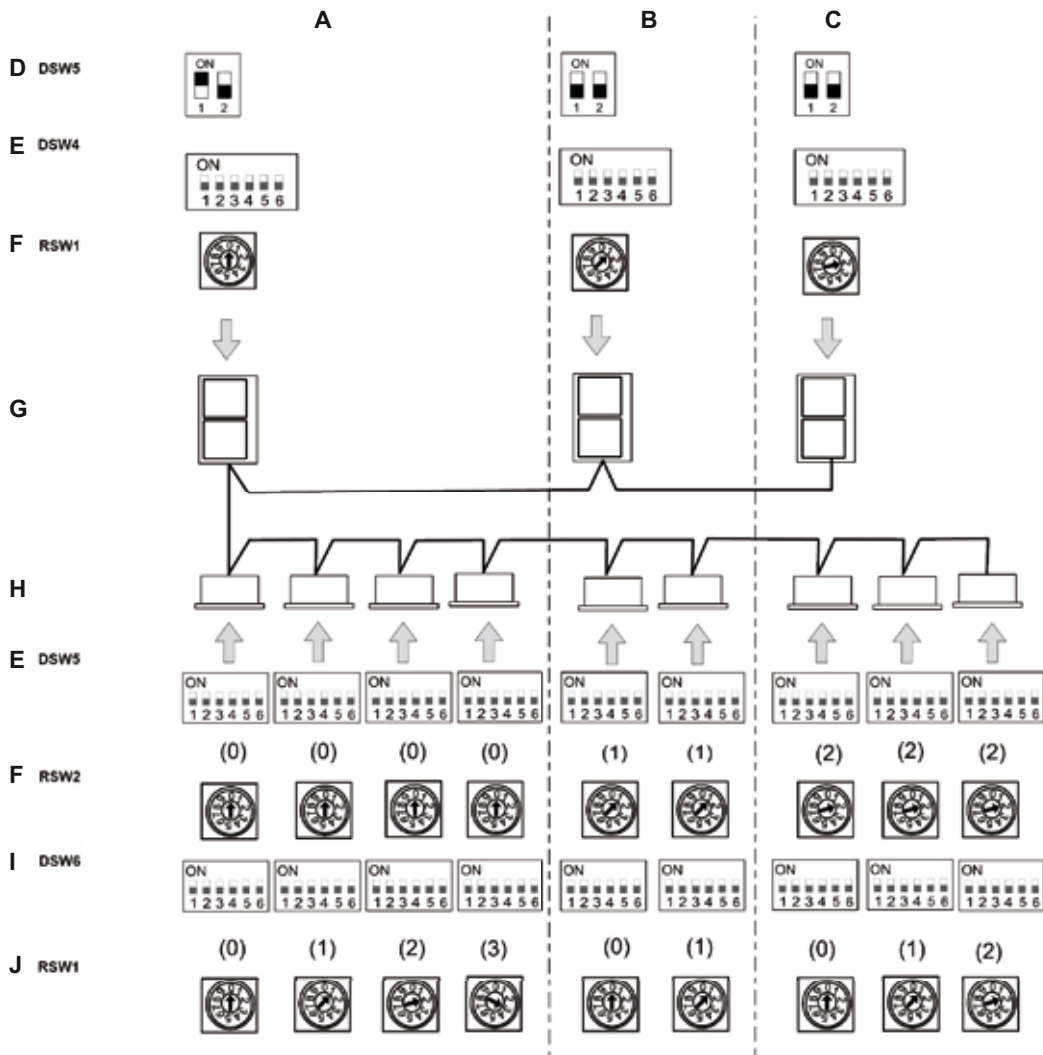

A: Cycle No. 0.

B: Cycle No. 1.

C: Cycle No. 2.

D: Terminal resistance.

E: No. of refrigerant cycle (setting for the tenth digit).







F: No. of refrigerant cycle (setting for the last digit).

G: Outdoor units.

H: Indoor units.

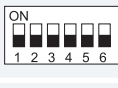
I: Address of the indoor unit (setting for the tenth digit).

J: Address of the indoor unit (setting for the tenth digit).

Unit	Name of DIP switch	Mark	Setting before the Shipment	Function
Outdoor Unit	Refrigerant cycle	DSW4 RSW1	 	For setting the refrigerant cycle address of the outdoor unit. Set the DSW4 and RSW1 to overlap the setting of other outdoor units in the same H-LINK system.
	Resistance of terminal	DSW5		To adapt the impedance of the transmission circuit, adjust DSW5 according to the number of outdoor units of the H-LINK system.
Indoor Unit	Refrigerant cycle	DSW5 RSW2	 	For setting the refrigerant cycle address of the indoor unit. Set the DSW5 and RSW2 corresponding to the address of outdoor unit in the same refrigerant cycle.
	Address of the indoor unit	DSW6 RSW1	 	Setting indoor unit address. Set the DSW6 and RSW1 not to overlap the setting of other indoor units in the same refrigerant cycle. (If no set, the automatic address function is performed.)

4

4.5.4 Examples of the system of connection between H-LINK and H-LINK II units

In the case of mixed systems with H-LINK and H-LINK II, set the H-LINK units in the first 16 position of the system, as in the following example where 42 systems are connected, 16 with indoor FSN1E units and 26 with indoor FSN2E units.

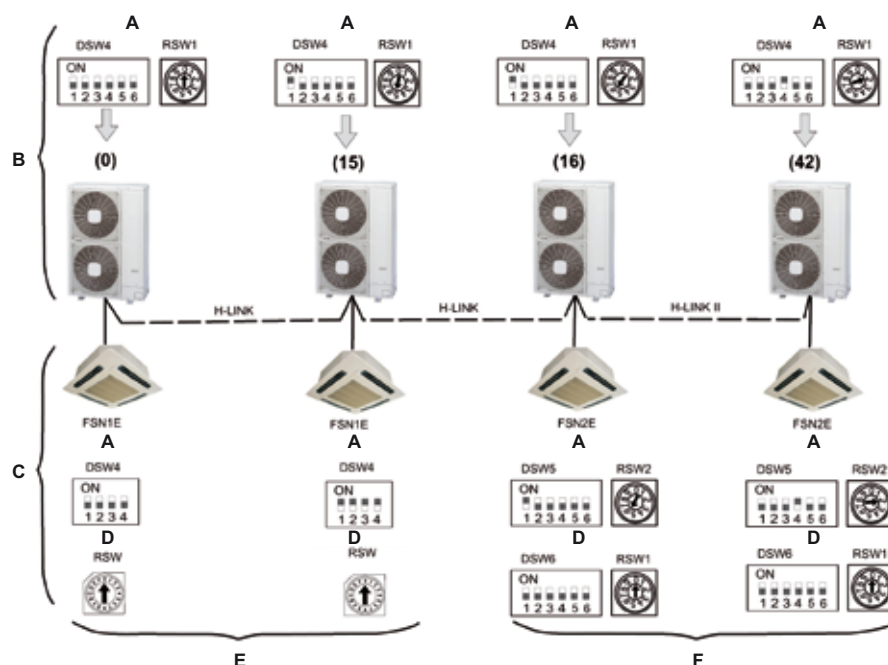

A: Refrigerant cycle.

B: Outdoor unit.

C: Indoor unit.

D: Indoor unit address.

E: Either the current remote control switch (H-LINK) or the new one (H-LINK II) can be used.

F: Only the new remote control switch (H-LINK II) can be used.



NOTE

- The maximum number of indoor units than an H-LINK II can control is 160.
- If you use PSC-5S and the CSNET WEB 2.0 (systems only compatible with H-LINK) bear in mind that it will only recognize 16 indoor and 16 outdoor units.

4.5.5 Examples of H-LINK II system

Two cases:

1. Using H-LINK II system for air conditioning systems without a central control device (CSNET WEB or PSC-A64S).

- Line connection with all units (including Utopia and/or Set Free, Mini Set Free and DC Inverter).

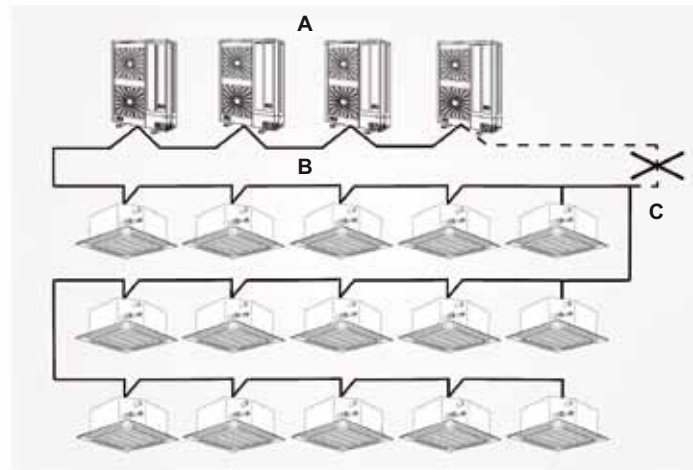

A: Outdoor units.

B: Indoor units.

C: Do not install wiring in a loop.

- Line connection for each floor.

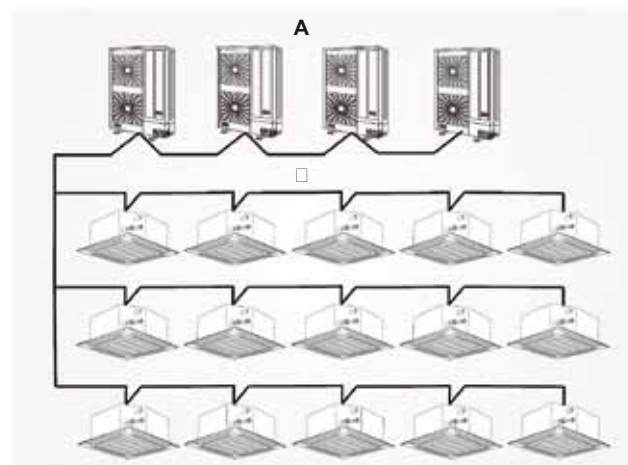

A: Outdoor units.

B: Indoor units.

- Connection with one main line and with the branch lines for the units.

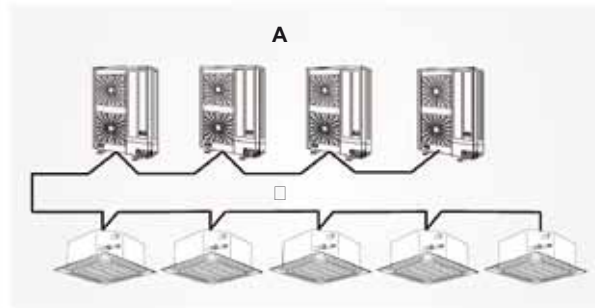

A: Outdoor units.

B: Indoor units.

CAUTION

- *The maximum number of units that can be connected is 64 outdoor units and 160 indoor units (including Utopia and/or Set Free, Mini Set-free).*
- *Do not install the wiring in a loop.*
- *If the H-LINK II system is not used when carrying out the electrical wiring as shown above, it must be used once the wiring of the instrument is completed. The DIP switches must therefore be set as specified in the DIP switches on the PCB.*

2. Using the H-LINK II system for air conditioning systems with a central control device (CSNET WEB or PSC-A64S)

- If the central control device is used when carrying out electrical wiring, the CS-NET WEB can be connected at any point of the H-LINK II wiring.

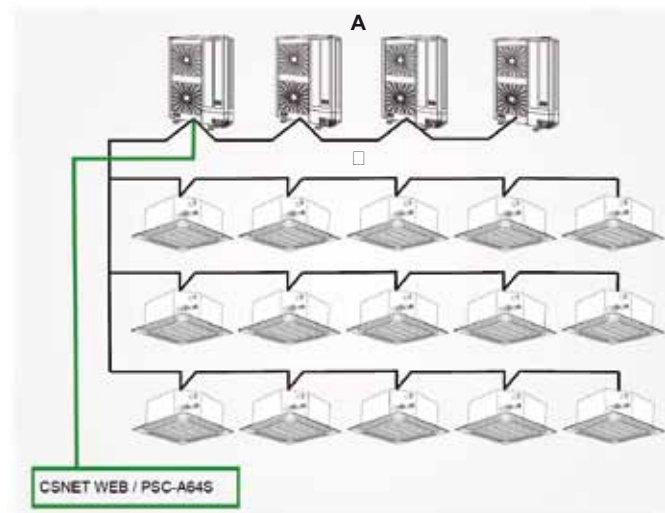

A: Outdoor units.

B: Indoor units.

- If the central control device is not used when electrical wiring is carried out, you must connect the H-LINK II wiring to all the systems. The easiest method is usually to connect the outdoor units.

NOTE

For CSNET WEB 2.0 the limitations are those corresponding to H-LINK.

4.6 System Control

4.6.1 Individual Operation

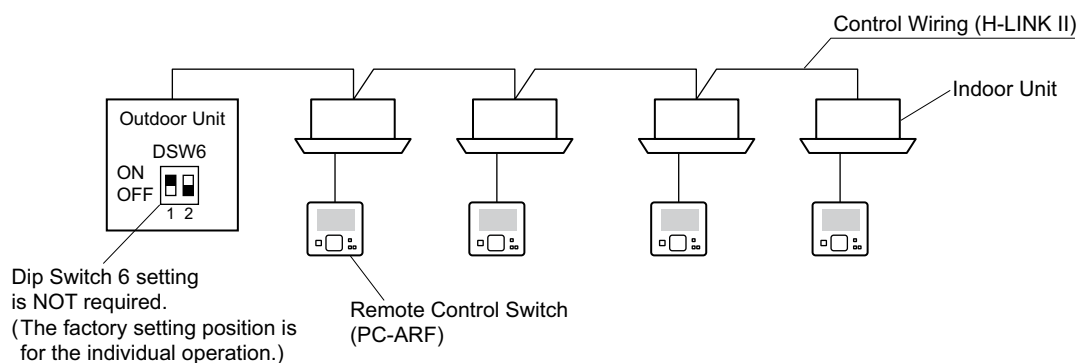

Individual Thermo ON/OFF Operation

The individual Thermo ON/OFF is available to be controlled each indoor unit even if multiple indoor units are controlled simultaneously by one remote control switch.

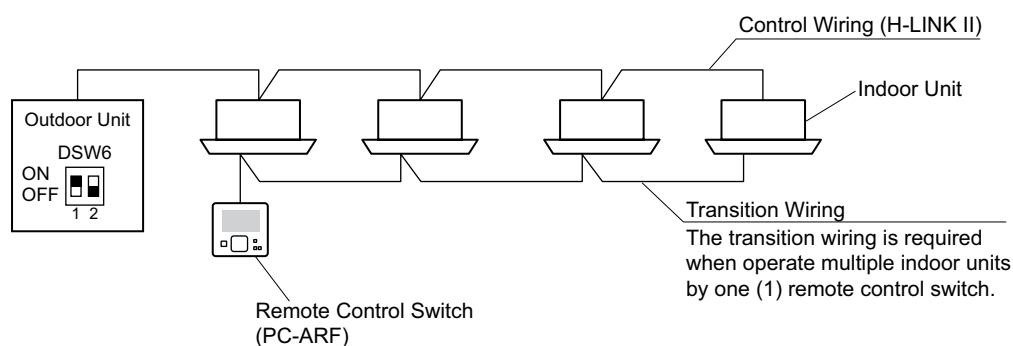

Control Method	by each Optional Remote Control Switch	
Operation Method	by One Group	
(1) ON/OFF	Yes	
(2) Setting of Operation Mode	Yes	*1)
(3) Room Temperature Setting	Yes	
(4) Fan Speed Setting	Yes	
(5) Timer Setting	Yes	
(6) ON/OFF by Timer Control	Yes	
(7) Operation Indication	Yes	
(8) Alarm Indication	Yes	
(9) Self-Checking	Yes	
(10) Test Mode	Yes	
(11) Individual Louver Setting	Yes	*2)
(12) Motion Sensor Setting	Yes	*3)



NOTE

- **Yes: Available**
- ***1) Cooling and heating can not be operated simultaneously.**
- ***2) Only for RCI-FSN3 series with PC-ARF**
- ***3) Only for RCI-FSN3 + P-AP160NAE + PC-ARF**
- **Do not mix other indoor unit, air panel (P-AP160NA1) and remote control switch (PC-ARF) if set from one remote control switch.**

4.6.2 Simultaneous Operation

This unit can be operated simultaneously with twin, triple and quad combinations.

One remote control switch (PC-ARF) can control without transition wiring up to 4 units of FSN2 series or later model types (H-LINK II supported models) simultaneously (Available if it is with the transition wiring.)

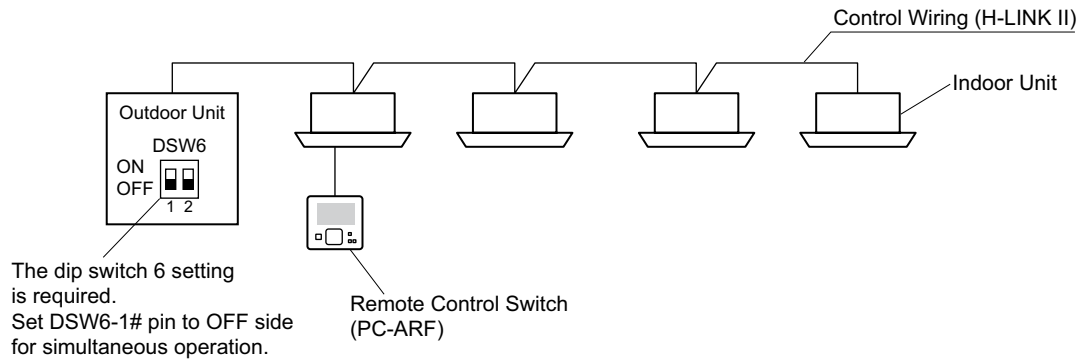

Control Method		by each Optional Remote Control Switch	
Operation Method		by One Group	
(1)	ON/OFF	Yes	
(2)	Setting of Operation Mode	Yes	*1)
(3)	Room Temperature Setting	Yes	
(4)	Fan Speed Setting	Yes	
(5)	Timer Setting	Yes	
(6)	ON/OFF by Timer Control	Yes	
(7)	Operation Indication	Yes	
(8)	Alarm Indication	Yes	
(9)	Self-Checking	Yes	
(10)	Test Mode	Yes	
(11)	Individual Louver Setting	Yes	*2)
(12)	Motion Sensor Setting	Yes	*3)



NOTE

- **Yes: Available**
- ***1) Cooling and heating can not be operated simultaneously.**
- ***2) Only for RCI-FSN3 series with PC-ARF**
- ***3) Only for RCI-FSN3 + P-AP160NAE + PC-ARF**
- **Do not mix other indoor unit, air panel (P-AP160NA1) and remote control switch (PC-ARF)**

4.7 Electrical wiring diagrams

4.7.1 RAS-(2-2.5)HVNP / RAS-3HVNC (1~ 230V 50Hz)

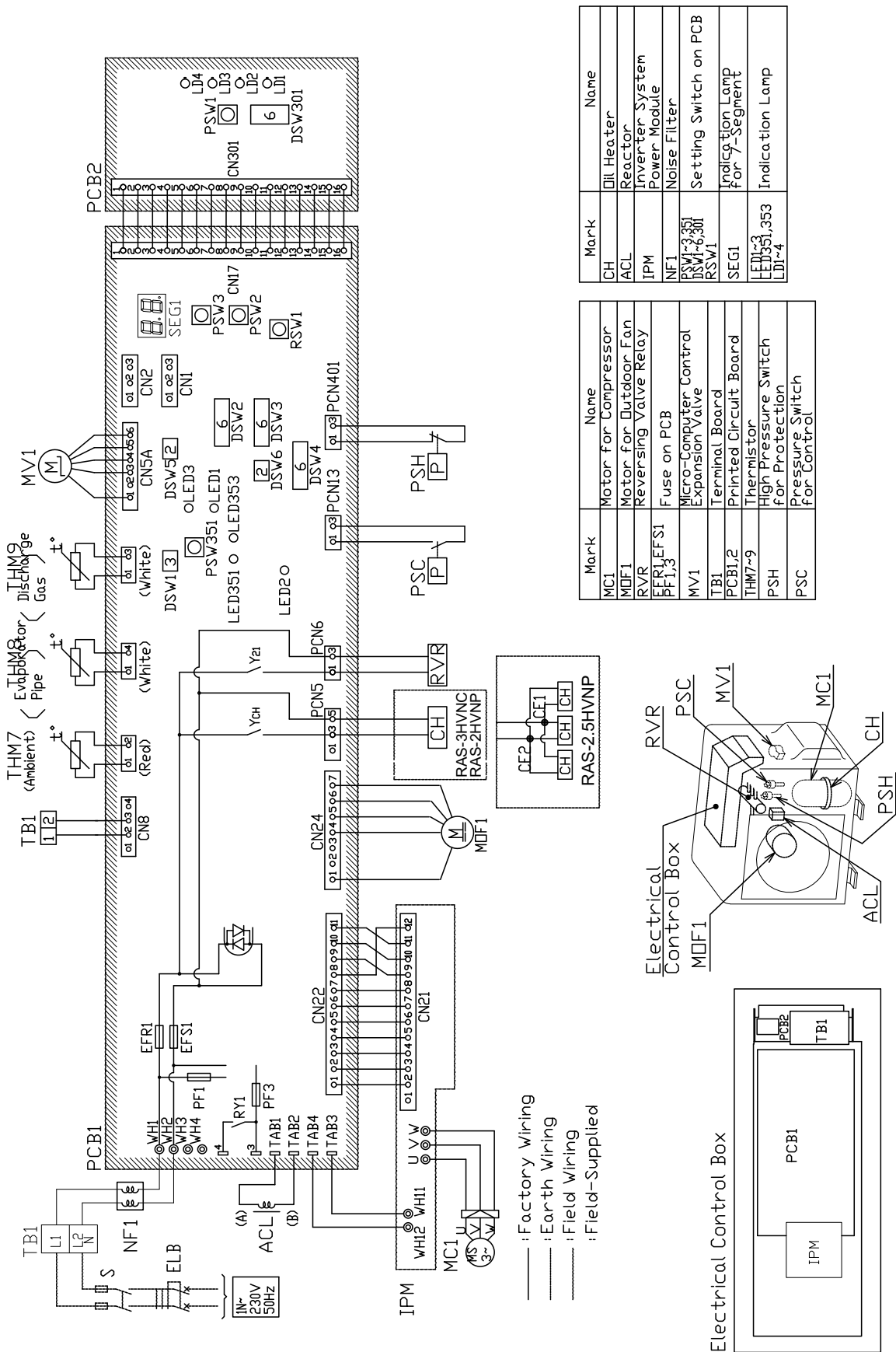

Mark	Name
CH	Oil Heater
ACL	Reactor
IPM	Inverter System Power Module
NF1	Noise Filter
PSW1~3,351	Setting Switch on PCB
DSW1~6,301	Indication Lamp for 7-Segment
SEGI	Indication Lamp
LED1~3,353	Indication Lamp
LD1~4	Indication Lamp

Mark	Name
MC1	Motor for Compressor
MDF1	Motor for Outdoor Fan
RVR	Reversing Valve Relay
EFR1,EFS1	Fuse on PCB
PF1~3	Micro-Computer Control Expansion Valve
MV1	Terminal Board
TB1	Printed Circuit Board
PCB1,2	Thermistor
THM7~9	High Pressure Switch
PSH	Pressure Switch for Protection
PSC	Pressure Switch for Control

4.7.2 RAS-3HVNP (1~ 230V 50Hz)

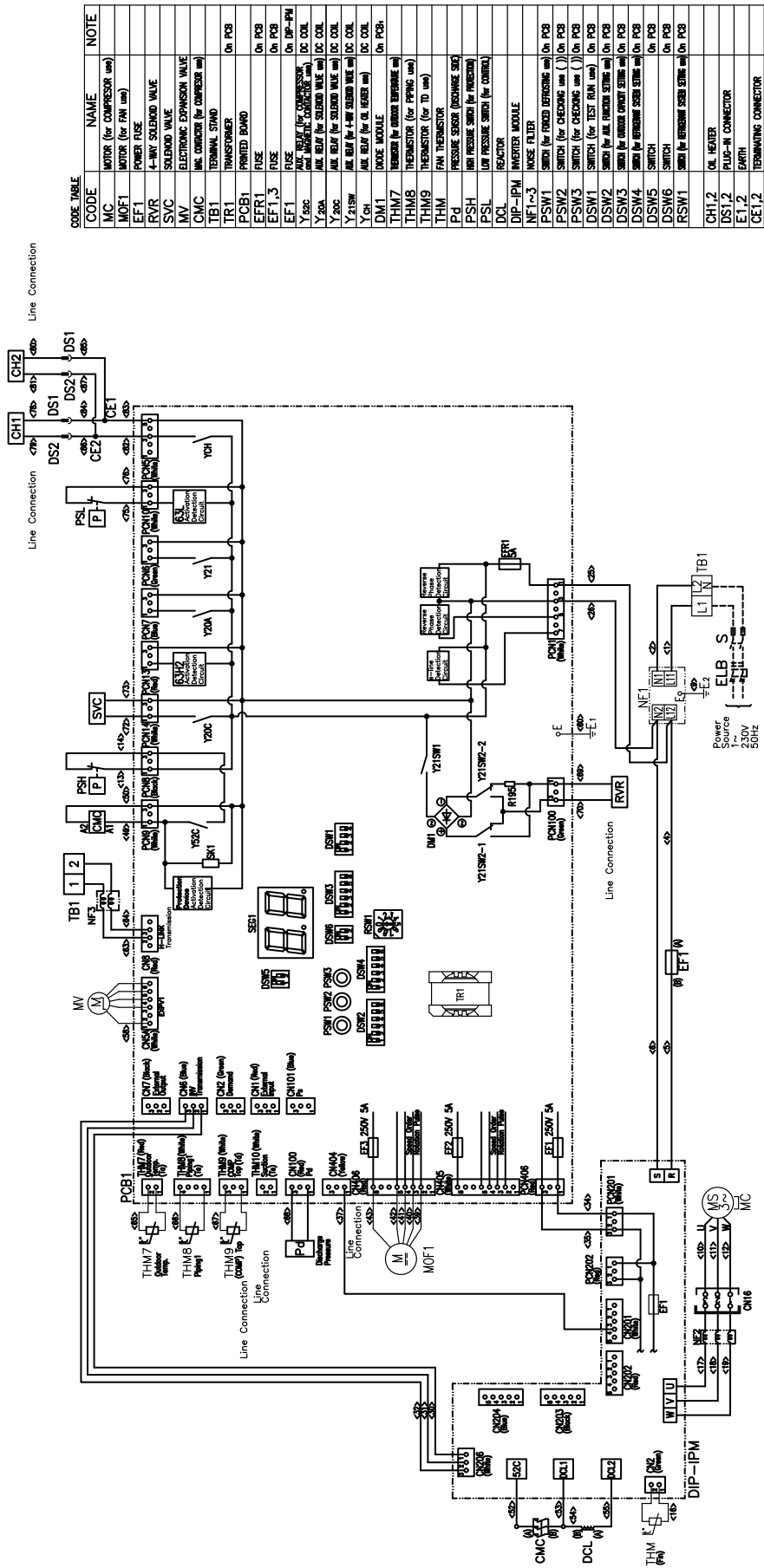

CODE	NAME	NOTE
MC	MOTOR (for COMPRESSOR use)	
MOF1	MOTOR (for FAN use)	
EF1	POWER FUSE	
RV/R	4-WAY SOLENOID VALVE	
SVC	SOLENOID VALVE	
MY	ELECTRONIC EXPANSION VALVE	
CM/C	CMC (for COMPRESSOR use)	
TB1	TERMINAL STAND	On PCB
TR1	TRANSFORMER	On PCB
PCB1	PRINTED BOARD	On PCB
EF1.1	FUSE	On PCB
EF1.2	FUSE	On PCB
EF1.3	FUSE	On PCB
Y20A	RELAY (for COMPRESSOR use)	On PCB
Y20C	RELAY (for SOLENOID VALVE use)	On PCB
Y21	RELAY (for SOLENOID VALVE use)	On PCB
Y22	RELAY (for 4-WAY SOLENOID VALVE use)	On PCB
DM1	DIODE MODULE	On PCB
THM7	TEMPERATURE SENSOR (for INVERTER use)	On PCB
THM8	TEMPERATURE SENSOR (for PIPING use)	On PCB
THM9	TEMPERATURE SENSOR (for TB use)	On PCB
THM	FAN THERMISTOR	On PCB
PSH	PRESSURE SWITCH (DISCHARGE SIDE)	On PCB
PSL	LOW PRESSURE SWITCH (for FAN use)	On PCB
DCL	DIODE	On PCB
DIP-IPM	INVERTER MODULE	On PCB
NFT-3	NOISE FILTER	On PCB
PSW1	SWITCH (for FIXED DEFROSTING use)	On PCB
PSW2	SWITCH (for CHECKING use)	On PCB
PSW3	SWITCH (for CHECKING use)	On PCB
DSW1	SWITCH (for TEST FAN use)	On PCB
DSW2	SWITCH (for ALL FAN use)	On PCB
DSW3	SWITCH (for FAN use)	On PCB
DSW4	SWITCH (for FAN use)	On PCB
DSW5	SWITCH	On PCB
DSW6	SWITCH	On PCB
RSW1	SWITCH (for REMOTE START use)	On PCB
GH1.2	OIL HEATER	On PCB
DS1.2	PLUG-IN CONNECTOR	On PCB
E1.2	EARTH	On PCB
GE1.2	TERMINATING CONNECTOR	On PCB

4.7.3 RAS-(4-6)HVNPE (1~ 230V 50Hz)

CODE	TABLE	NAME	NOTE
MC		MOTOR (for COMPRESSOR use)	
MOF1,2		MOTOR (for FAN use)	
EF1		POWER FUSE	
RVR		4-WAY SOLENOID VALVE	
SVA,C		SOLENOID VALVE	
MV		ELECTRONIC EXPANSION VALVE	
CMC		CMC CONSOLE (for COMPRESSOR use)	
TB1		TERMINAL STAND	On PCB
PCB1		PRINTED BOARD	
EF1,3		FUSE	On PCB
EF1		FUSE	On DIP-IPM
Y150C		AUX. RELAY (for COMPRESSOR and MAGNETIC CONTACTOR use)	DC COIL
Y200A		AUX. RELAY (for SOLENOID VALVE use)	DC COIL
Y215M		AUX. RELAY (for 4-WAY SOLENOID VALVE use)	DC COIL
Y215W		AUX. RELAY (for 4-WAY SOLENOID VALVE use)	DC COIL
DM1		DIODE MODULE	DC COIL
THIM7		TEMPERATURE SENSITIVE RESISTOR (for UNDER SUPERHEAT use)	
THIM8		TEMPERATURE SENSITIVE RESISTOR (for PIPING use)	
THM		FAN THERMISTOR	
Pd		PRESSURE SWITCH (DISCHARGE SIDE)	
PSH		HIGH PRESSURE SWITCH (for PROTECTING)	
PSL		LOW PRESSURE SWITCH (for CONTROL)	
DCL		REACTOR	
DIP-IPM		INVERTER MODULE	
NF1~3		NOISE FILTER	
PSW1		SWITCH (for FORCED DEFROSTING use)	On PCB
PSW2		SWITCH (for CHECKING use (A))	On PCB
PSW3		SWITCH (for CHECKING use (B))	On PCB
DSW1		SWITCH (for TEST RUN use)	On PCB
DSW2		SWITCH (for AUX. FUNCTION SETTING use)	On PCB
DSW3		SWITCH (for UNDER CARRY SETTING use)	On PCB
DSW4		SWITCH (for DEFROSTING SETTING use)	On PCB
DSW5		SWITCH	On PCB
DSW6		SWITCH	On PCB
RSW1		SWITCH (for DEFROSTING SETTING use)	On PCB
CH		OIL HEATER	
DS1,2		FUSE-IN CONNECTOR	
E1,2		EMTH	

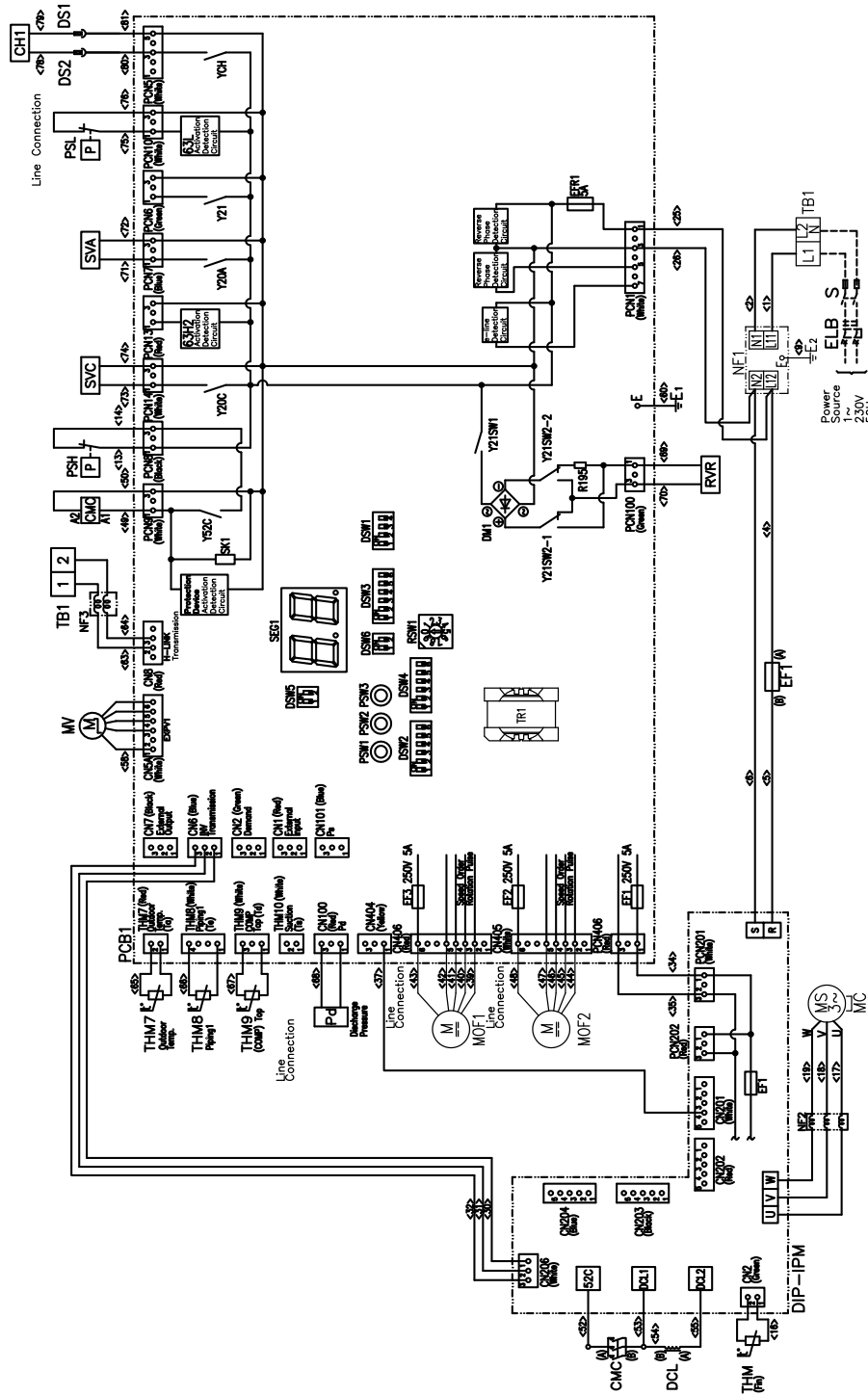

4.7.4 RAS-(4-6)HNPE (3N~ 400V 50Hz)

CODE	NAME	NOTE
MC	MOTOR (for COMPRESSOR use)	
MOF1,2	MOTOR (for FAN use)	
EF1,2	POWER FUSE	
RYVR	4-WAY SELENOID VALVE	
SVA/C	SELENOID VALVE	
MV	ELECTRONIC EXPANSION VALVE	
CMC	CMC CONECTOR (for COMPRESSOR use)	
TB1	TERMINAL STAND	On PCB
TR1	TRANSFORMER	On PCB
PCB1	PRINTED BOARD	
EF1~3	FUSE	On PCB
EF1	FUSE	On DIP-IPM
Y200	Y200 RELAY (for COMPRESSOR use)	DC COIL
Y20A	Y20A RELAY (for SELENOID VALVE use)	DC COIL
Y21SW	Y21SW RELAY (for 4-WAY SELENOID VALVE use)	DC COIL
YCh	YCh RELAY (for OIL FLEET use)	DC COIL
DM1	DIODE MODULE	
THM7	TEMPERATURE SENSOR (for SELENOID VALVE use)	
THM8	TEMPERATURE SENSOR (for PFC use)	
THM9	TEMPERATURE SENSOR (for TD use)	
PSH	PRESSURE SENSOR (DISCHARGE SIDE)	
PSL	LOW PRESSURE SWITCH (for CONTROL)	
DCL	DIODE REACTOR	
DIP-IPM	INVERTER MODULE	
NF1~8	NOISE FILTER	
PSW1	SWITCH (for FROST DEFROSTING use)	On PCB
PSW2	SWITCH (for CHECKING use (A))	On PCB
PSW3	SWITCH (for CHECKING use (B))	On PCB
DSW1	SWITCH (for TEST RUN use)	On PCB
DSW2	SWITCH (for OIL FLEET SYSTEM use)	On PCB
DSW3	SWITCH (for OIL FLEET SYSTEM use)	On PCB
DSW4	SWITCH (for OIL FLEET SYSTEM use)	On PCB
DSW5	SWITCH (for OIL FLEET SYSTEM use)	On PCB
DSW6	SWITCH (for OIL FLEET SYSTEM use)	On PCB
RSW1	SWITCH (for REFRIGERANT SEEB SYSTEM use)	On PCB
CH	OIL HEATER	
DS1,2	RELAY-IN CONNECTOR	
EF1,2	FUSE	

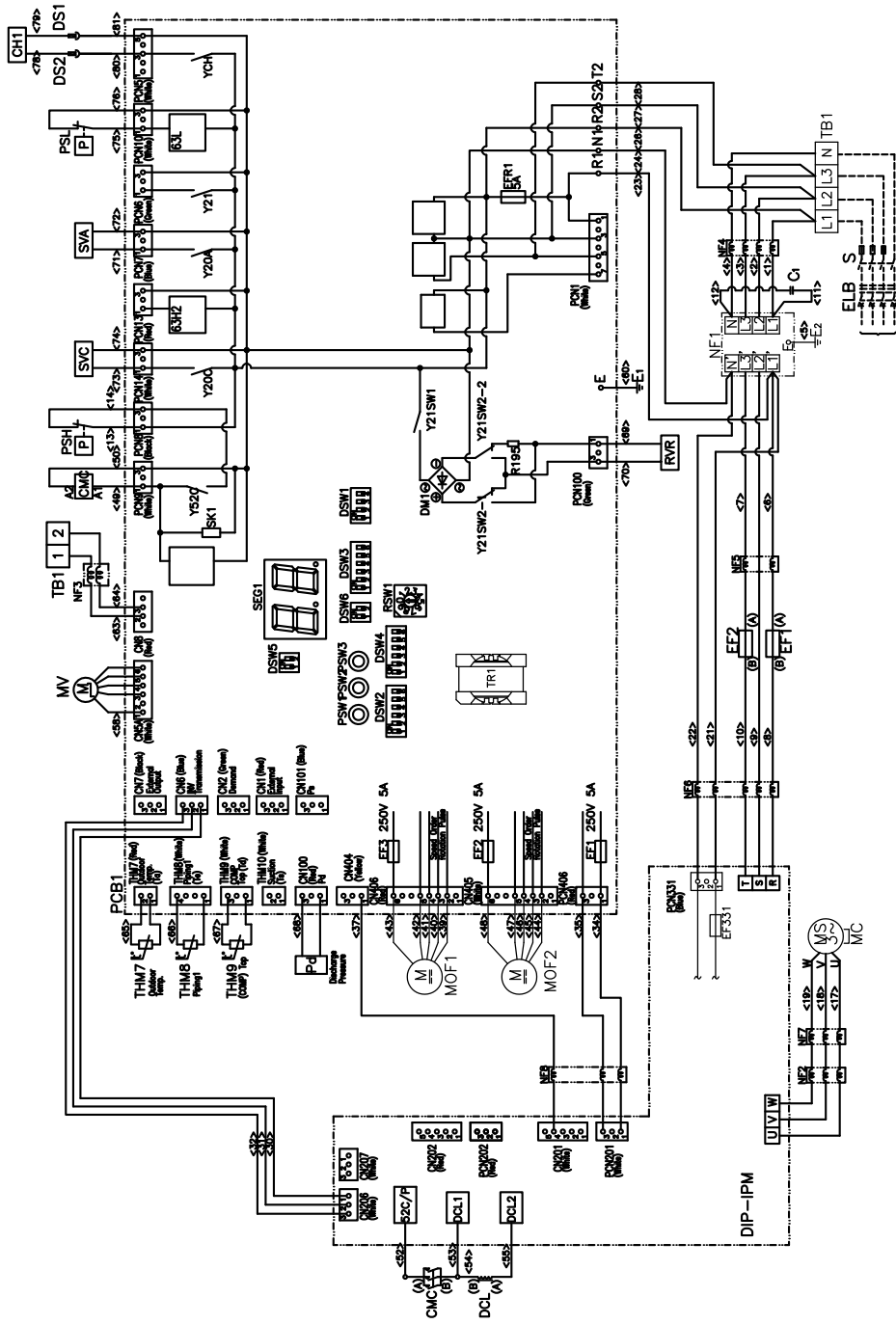

XEK01263_1

4.7.5 RAS-(4-6)HVNCE (1N~ 230V 50Hz)

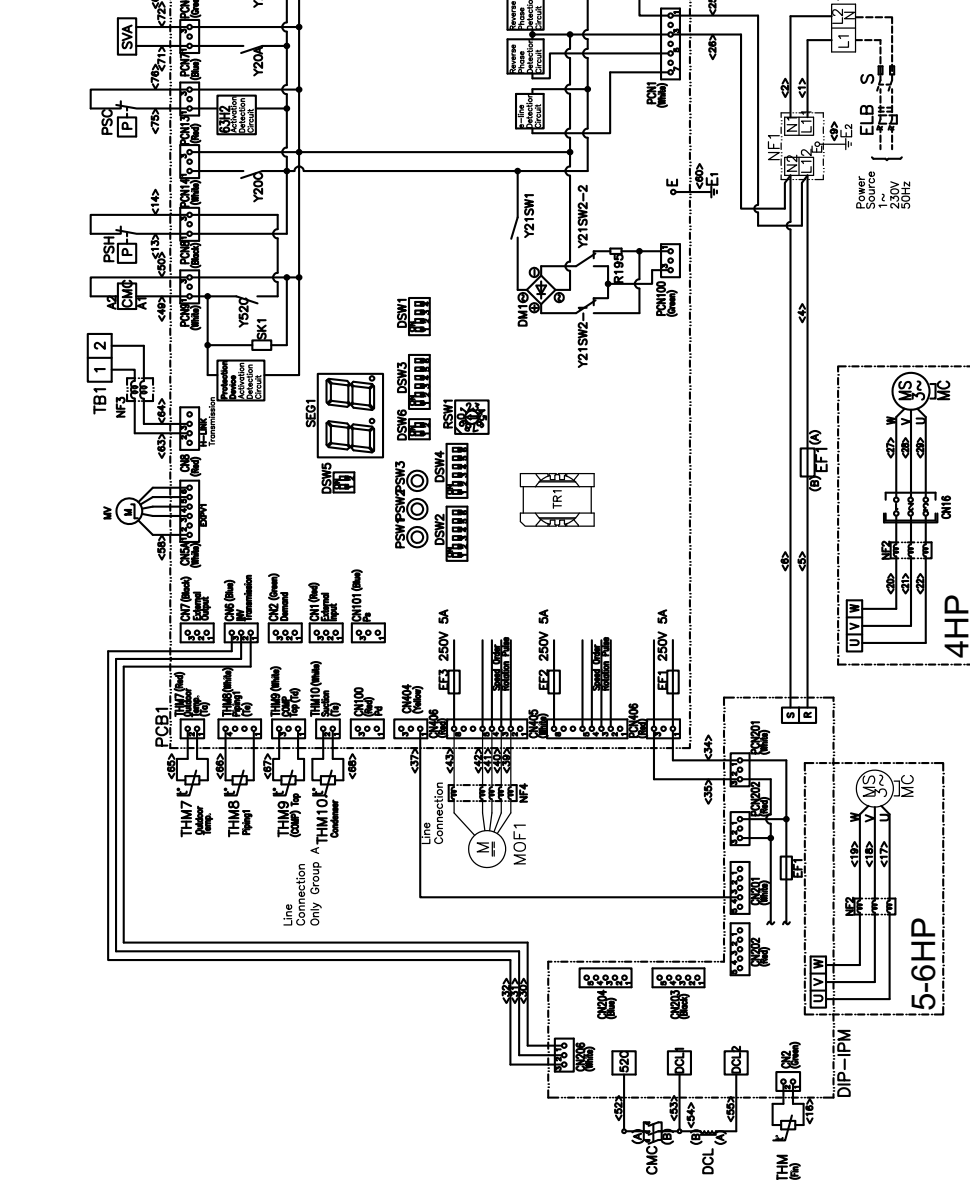
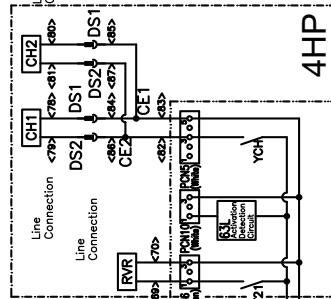
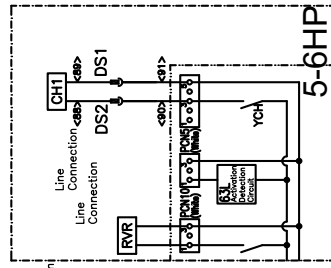

CODE	NAME	NOTE
MC	MOTOR (for COMPRESSOR use)	
MOF1	MOTOR (for FAN use)	
EF1	POWER FUSE	
RVR	4-WAY SOLENOID VALVE	
SVA	SOLENOID VALVE	
MX	ELECTRONIC EXPANSION VALVE	
CMC	CMC CONDENSER (for COMPRESSOR use)	
TR1	TRANSFORMER	On PCB
PCB1	PRINTED BOARD	
EF1~3	FUSE	On PCB
EF1	FUSE	On PCB
EF2	FUSE	On PCB
EF3	FUSE	On PCB
Y21SW	ALL RELAY (for COMPRESSOR use)	DC COIL
Y21SW	ALL RELAY (for SOLENOID VALVE use)	DC COIL
Y21SW	ALL RELAY (for 4-WAY SOLENOID VALVE use)	DC COIL
Y21SW	ALL RELAY (for OIL HEATER use)	DC COIL
DM1	DIODE MODULE	
THM7	THERMISTOR (for OIL HEATING use)	
THM8	THERMISTOR (for PIPING use)	
THM9	THERMISTOR (for TD use)	
THM10	THERMISTOR (for CONDENSER use)	
THM	PN THERMISTOR	
PSH	HIGH PRESSURE SWITCH (for INVERSION)	
PSL	LOW PRESSURE SWITCH (for CONTROL)	
DCL	REACTOR	
DIP-IPM	INVERTER MODULE	
NF1~4	NOISE FILTER	
PSW1	SWITCH (for FIXED DEFROSTING use)	On PCB
PSW2	SWITCH (for CHECKING use (C))	On PCB
PSW3	SWITCH (for CHECKING use (A))	On PCB
DSW1	SWITCH (for TEST RUN use)	On PCB
DSW2	SWITCH (for A.I.K. RUNNING SETTING use)	On PCB
DSW3	SWITCH (for OIL HEATER SETTING use)	On PCB
DSW4	SWITCH (for INVERSION SETTING use)	On PCB
DSW5	SWITCH	On PCB
DSW6	SWITCH	On PCB
RSW1	SWITCH (for INVERSION STOP SETTING use)	On PCB
CH1,2	OIL HEATER	
E1,2	EMPH	
CE1,2	TERMINATING CONNECTOR	

4.7.6 RAS-(4-6)HNCE (3N~ 400V 50Hz)

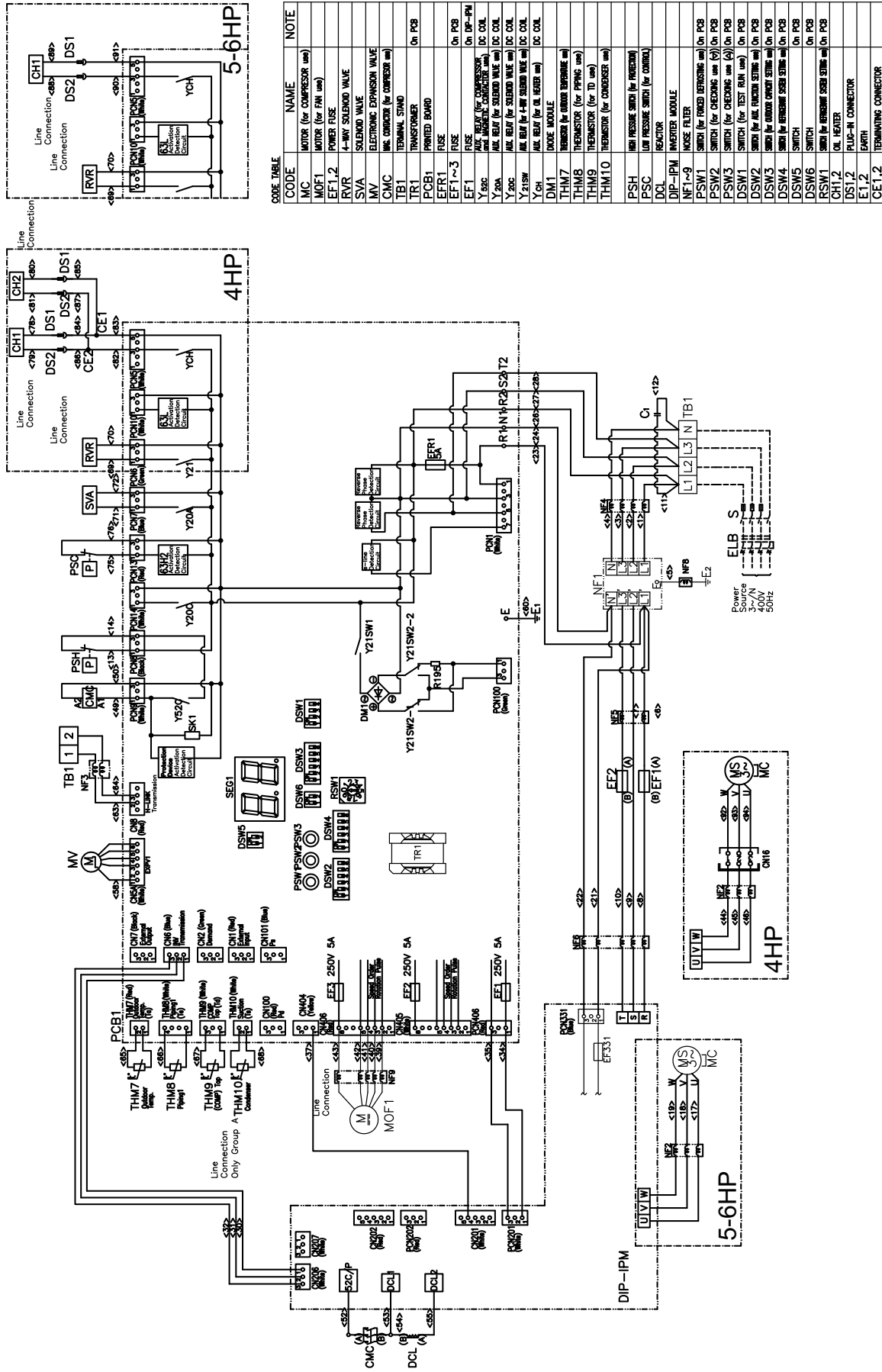

CODE	NAME	NOTE
MC	MOTOR (for COMPRESSOR use)	
MOF1	MOTOR (for FAN use)	
EF1.2	POWER FUSE	
RVR	4-WAY SOLENOID VALVE	
SVA	SOLENOID VALVE	
MV	ELECTRONIC EXPANSION VALVE	
CMC	CMC CONDENSER (for COMPRESSOR use)	
TR1	TERMINAL STAND	On PCB
PCB1	PRINTED BOARD	
EF1~3	FUSE	On PCB
EF1	FUSE	On DIP-IPM
Y200	AUX. RELAY (for COMPRESSOR, and MAGNETIC CONDENSATOR use)	DC COIL
Y201	AUX. RELAY (for SOLENOID VALVE use)	DC COIL
Y202	AUX. RELAY (for SOLENOID VALVE use)	DC COIL
Y203	AUX. RELAY (for 4-WAY SOLENOID VALVE use)	DC COIL
Y204	AUX. RELAY (for 4-WAY SOLENOID VALVE use)	DC COIL
Y205	AUX. RELAY (for 4-WAY SOLENOID VALVE use)	DC COIL
Y206	AUX. RELAY (for 4-WAY SOLENOID VALVE use)	DC COIL
Y207	AUX. RELAY (for 4-WAY SOLENOID VALVE use)	DC COIL
Y208	AUX. RELAY (for 4-WAY SOLENOID VALVE use)	DC COIL
Y209	AUX. RELAY (for 4-WAY SOLENOID VALVE use)	DC COIL
Y210	AUX. RELAY (for 4-WAY SOLENOID VALVE use)	DC COIL
Y211	AUX. RELAY (for 4-WAY SOLENOID VALVE use)	DC COIL
Y212	AUX. RELAY (for 4-WAY SOLENOID VALVE use)	DC COIL
Y213	AUX. RELAY (for 4-WAY SOLENOID VALVE use)	DC COIL
Y214	AUX. RELAY (for 4-WAY SOLENOID VALVE use)	DC COIL
Y215	AUX. RELAY (for 4-WAY SOLENOID VALVE use)	DC COIL
Y216	AUX. RELAY (for 4-WAY SOLENOID VALVE use)	DC COIL
Y217	AUX. RELAY (for 4-WAY SOLENOID VALVE use)	DC COIL
Y218	AUX. RELAY (for 4-WAY SOLENOID VALVE use)	DC COIL
Y219	AUX. RELAY (for 4-WAY SOLENOID VALVE use)	DC COIL
Y220	AUX. RELAY (for 4-WAY SOLENOID VALVE use)	DC COIL
DM1	DIODE MODULE	
THM7	THERMISTOR (for AIRFLOW DETECTION use)	
THM8	THERMISTOR (for FAN use)	
THM9	THERMISTOR (for TD use)	
THM10	THERMISTOR (for CONDENSER use)	
PSH	HIGH PRESSURE SWITCH (for INVERTER)	
PSC	LOW PRESSURE SWITCH (for CONTROL)	
DCL	REACTOR	
DIP-IPM	INVERTER MODULE	
MF1~9	MICRO FILTER	
PSW1	SWITCH (for FIXED DEFROSTING use)	On PCB
PSW2	SWITCH (for CHECKING use (a))	On PCB
PSW3	SWITCH (for CHECKING use (b))	On PCB
DSW1	SWITCH (for TEST RUN use)	On PCB
DSW2	SWITCH (for A.I.C. FUNCTION SETTING use)	On PCB
DSW3	SWITCH (for INVERTER CARRIER SETTING use)	On PCB
DSW4	SWITCH (for INVERTER SPEED SETTING use)	On PCB
DSW5	SWITCH	On PCB
DSW6	SWITCH	On PCB
DSW7	SWITCH	On PCB
RSW1	SWITCH (for REVERSE SPEED SETTING use)	On PCB
CHT.2	OIL HEATER	
DS1.2	PLUG-IN CONNECTOR	
E1.2	EARTH	
CE1.2	TERMINATING CONNECTOR	

XEK01265_1

4.7.7 RAS-(8-10)HN(P/C)E (3N~ 400V 50Hz)

Code	Name of Parts	Remarks
MC	Motor (for Compressor)	
MOF1,2	Motor (for Fan)	
EF1,2	Fuse	
CMC	Control Module (for Compressor)	
SVAC	Solenoid Valve	
RVV	Magnetic 4 Way Valve	
MV	Electrical Expansion Valve	
TB1	Terminal Board	
E1,2	Earth	
TF1	Transformer	on PCB1
YH	Auxiliary Relay (Oil Heater)	DC Coil
YH1,2	Auxiliary Relay (Solenooid Valve)	DC Coil
Y21	Auxiliary Relay (Solenooid 4-Way Valve)	DC Coil
Y22	Auxiliary Relay (Compressor)	DC Coil
THM7	Thermistor (for Outdoor Air)	
THM8	Thermistor (for Piping)	
THM9	Thermistor (for Comp. Top)	
THM	Fin Thermistor	
Pd	Pressure Sensor (Discharge Side)	
PSH	High Pressure Switch (for Protection)	
PSL	Low Pressure Switch (Control)	
DCL	Reactor	
CB1,2	Capacitor	
DM	Diode Module	
IPM	Inverter Module	
PCB1	Control PCB	
PCB2	Inverter PCB	
PCB3	Power Source PCB	
NF1-5	Noise Filter	
EF1,2	Fuse	on PCB3
PSW1	Switch (Forced Defrosting)	on PCB1
PSW2	Switch (Checking)	on PCB1
PSW3	Switch (Checking)	on PCB1
DSW1	Switch (Test Run)	on PCB1
DSW2	Switch (Auxiliary Option Setting)	on PCB1
DSW3	Switch (Outdoor Capacity Setting)	on PCB1
DSW4	Switch (Refrigerant Cycle Setting)	on PCB1
DSW5	Switch	on PCB1
DSW6	Switch	on PCB1
Clu.Ctv	(Rheotrope Current Detector)	on PCB2
CS1,2	Capacitor	
ZNR	Surge Absorber	
R1,2	Resistor	
CH	Crunkcase Heater	
DS1,DS2	Plug-in Connector	

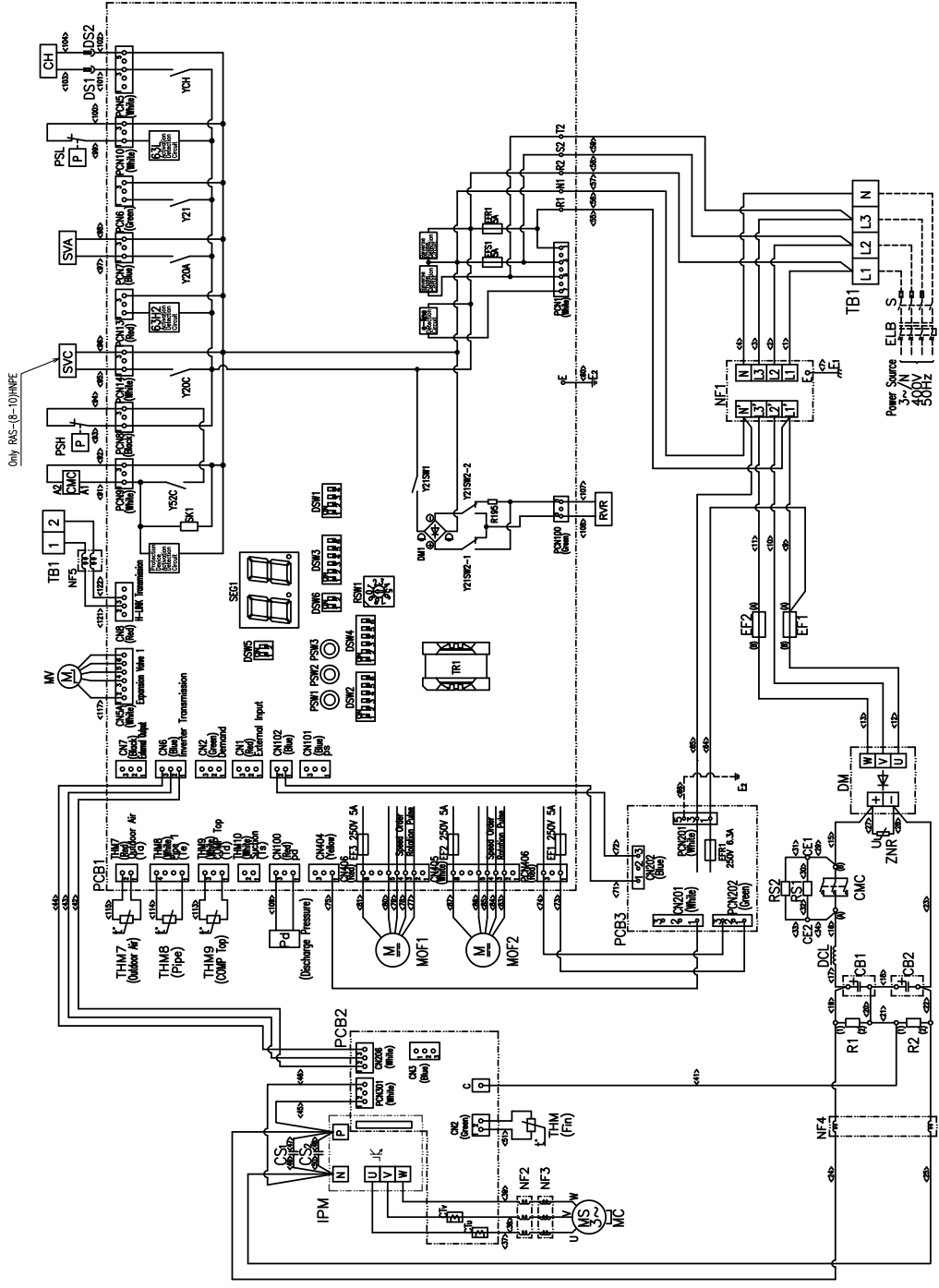

XEK01288_0

4.7.8 RAS-12HNP (3N~ 400V 50Hz) - Preliminary data

Code Table

Code	Name	Notes
MC	Motor (for Compressor)	
MFC1, 2	Motor (for Fan)	
PF1, 2	Power Fuse	
EF1, 2	Fuse	On PWB1
EFS1, 2	Fuse	On PWB1
EF1, 3	Fuse	
52C	Electronic Control (Compressor)	
20A	Solenoid Valve (HP Bypass)	
20C	Solenoid Valve (Gas Bypass)	
20F	Solenoid Valve (Oil return)	
21SH	Solenoid 4-Way Valve	
M	Electronic Expansion Valve	
CH	Oil Heater	
TB1	Terminal Stand (Power Source)	
TB2	Terminal Stand (Transmission)	
TR1	Transformer	On PWB1
E1, 2	Earth	
PWB1	Control PCB	
PWB2	Inverter PCB	
G3H1	High Pressure Switch (Protection)	
Pd	Pressure Sensor (Discharge Side)	
63L	Low Pressure Switch (Control)	
NF1~5	Noise Filter	
THM7~9	Thermistor	
THM	Fin Thermistor	
DCL	Reactor	
CB	Smoothing Capacitor	
DM	Diode Module	
C, C _{PM} , C _{TB}	Capacitor	
ZNR	Surge Absorber	
RS	Resistor	
IPM	Inverter Module	
PSW1	Switch (forced Defrosting)	On PWB1
PSW2	Switch (Checking (Δ))	On PWB1
PSW3	Switch (Checking (▽))	On PWB1
DSW1	Switch (Test Run)	On PWB1
DSW2	Switch (Auxiliary Function Setting)	On PWB1
DSW3	Switch (Outdoor Capacity Setting)	On PWB1
DSW4	Switch (Refrigerant System Setting)	On PWB1
DSW5	Switch	On PWB1
DSW6	Switch (function Setting)	On PWB1
RSW1	Switch (Refrigerant System Setting)	On PWB1
SW1	Switch (Transmission Damper)	On PWB1
SEG1	7-segment display	On PWB1
S	Circuit Breaker (field supplied)	
ELB	Earth Leakage Breaker (field supplied)	

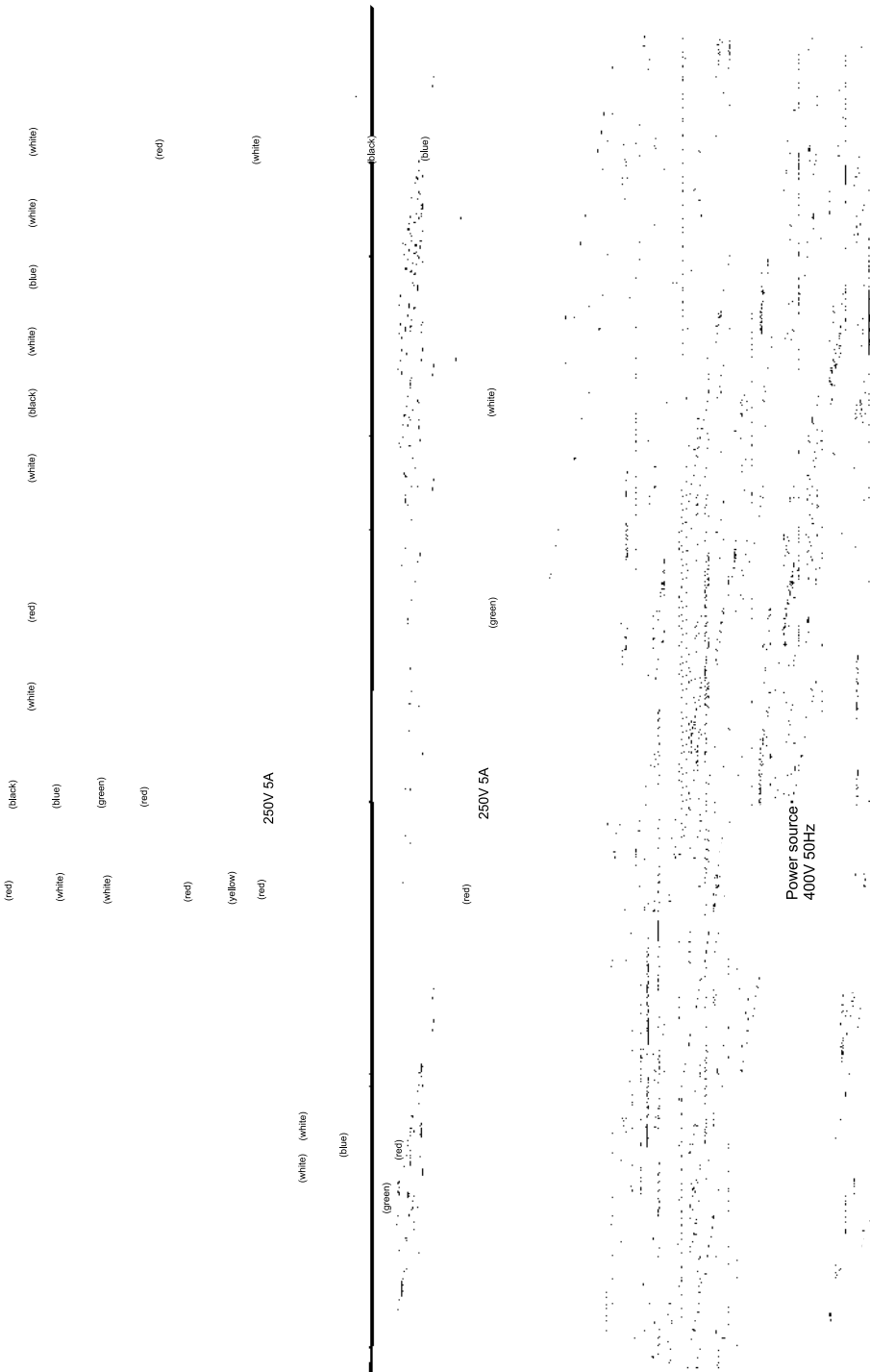

317S136064

4.7.9 RAS-12HNC (3N~ 400V 50Hz) - Preliminary data

Code	Name	Notes
MC	Motor (for Compressor)	
MFC1, 2	Motor (for Fan)	
PF1, 2	Power Fuse	On PWB1
EF1, 2	Fuse	On PWB1
EF1, 2	Fuse	
EF1, 3	Fuse	
S2C	Electromagnetic Contactor (Compressor)	
20A	Solenoid Valve (HP Bypass)	
20F	Solenoid Valve (Oil return)	
21	Solenoid 4-Way Valve	
M	Electronic Expansion Valve	
CH	Oil Heater	
TR1	Terminal Stand (Power Source)	
TR2	Terminal Stand (Transmission)	
TR1	Transformer	On PWB1
E1, 2	Earth	
PWB1	Control PCB	
PWB2	Inverter PCB	
6.3H1	High Pressure Switch Protection	
6.3H2	Low Pressure Switch Control	
NF1~7	Noise Filter	
THM7~10	Thermistor	
THM	Fin Thermistor	
DCL	Reactor	
CB	Soothing Capacitor	
DM	Diode Module	
C, CPM, CTB	Capacitor	
ZNR	Surge Absorber	
RS	Resistor	
IPM	Inverter Module	
PSW1	Switch (forced defrosting)	On PWB1
PSW2	Switch (Checking (Δ))	On PWB1
PSW3	Switch (Checking (∇))	On PWB1
DSW1	Switch (Test Run)	On PWB1
DSW2	Switch (Auxiliary Function Setting)	On PWB1
DSW3	Switch (Outdoor Capacity Setting)	On PWB1
DSW4	Switch (Defrost System Setting)	On PWB1
DSW5	Switch	On PWB1
DSW6	Switch (Function Setting)	On PWB1
RSM1	Switch (Defrost System Setting)	On PWB1
SW1	Switch (Transmission Damper)	On PWB1
SEG1	7-segment display	On PWB1
S	Circuit breaker (field supplied)	
ELB	Earth Leakage Breaker (field supplied)	

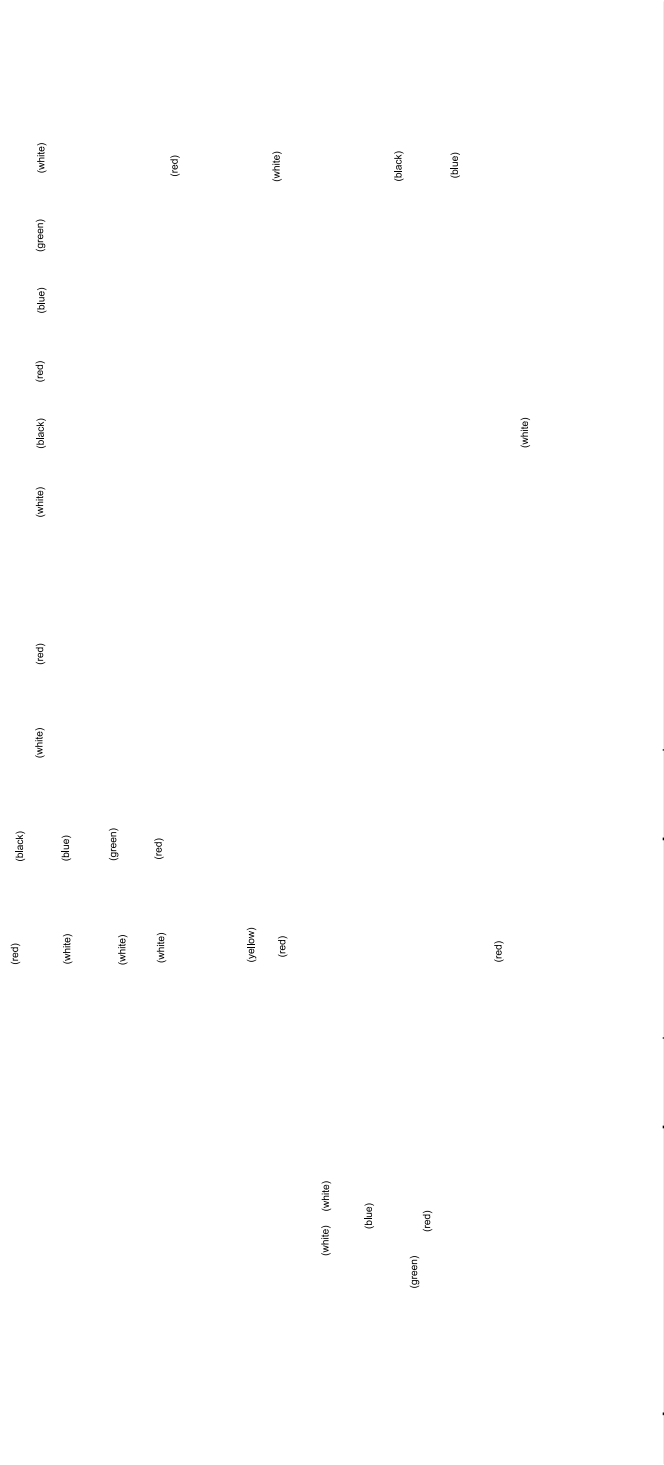

Power source
400V 50Hz

5 . Control System

Index

5.1.	Device control system	118
5.2.	Outdoor units PCB	120
5.2.1.	RAS-(2-2.5)HVNP / RAS-3HVNC.....	120
5.2.2.	RAS-3HVNPE.....	121
5.2.3.	RAS-(4-6)H(V)NPE.....	122
5.2.4.	RAS-(4-6)H(V)NCE	123
5.2.5.	RAS-(8-10)HN(P/C)E	124
5.2.6.	RAS-12HNP - Preliminary data	125
5.2.7.	RAS-12HNC - Preliminary data	126
5.3.	Protection and safety control.....	127
5.4.	Standard operation sequence	128
5.4.1.	Cooling operation	128
5.4.2.	Dry operation	130
5.4.3.	Heating operation	132
5.4.4.	Automatic cooling and heating operation	134
5.4.5.	Defrost operation control	135
5.5.	Standard control functions.....	138
5.5.1.	Freezing protection during cooling process or dry operation.....	138
5.5.2.	Prevention Control for High Pressure Increase during Cooling Operation	139
5.5.3.	Prevention control for excessively high discharge gas temperature	140
5.5.4.	Activation for protection device control.....	141
5.5.5.	Preheating control of compressor.....	142
5.5.6.	Prevention control for high pressure increase	143

5.1 Device control system

Control subject	Purpose		
	Cooling operation	Heating operation	Defrost operation
Control frequency of inverter compressor	The frequency control is determined with the next parameters: <ul style="list-style-type: none"> Ratio (I.U. capacity/O.U. capacity) for individual operation. Temperature difference between air inlet temperature and setting air temperature. 	The frequency control is determined with the next parameters: <ul style="list-style-type: none"> Ratio (I.U. capacity/O.U. capacity) for individual operation. Temperature difference between air inlet temperature and setting air temperature. 	Fixed frequency (For RAS-(2-2.5)HVNP and RAS-3HVNC: stop compressor during 30 sec. After defrosting condition was completed)
Opening degree expansion valve of outdoor unit	Fully open	<ul style="list-style-type: none"> Control range of expansion valve opening degree is determined to optimize temperature on the top of compressor. When number of I.U. is decreased, determined with I.U. capacity. Ratio of (before/after decrease or with above condition) for individual operation. 	Fully open
Opening degree expansion valve of indoor unit	<ul style="list-style-type: none"> Control range of expansion valve opening degree is determined to optimize I.U. gas pipe temp. (Tg) - I.U. liquid pipe temp. (TI) difference. The expansion valve opening degree is controlled according to the number of connected I.U. for individual operation. 	<ul style="list-style-type: none"> Specified opening degree at normal control starting. Afterward, controlled to optimize I.U. liquid pipe temp. (TI) The expansion valve opening degree is controlled according to the number of connected I.U. for individual operation. 	Specified opening degrees controlled by temp. on the top of compressor. (Td).
Outdoor fan control	<ul style="list-style-type: none"> Fan step is operated for O.U. liquid pipe temp. (Te) stabilization control. 	<ul style="list-style-type: none"> Fan Step is controlled according to O.U. liquid pipe temp. and temp. on the top of compressor. 	Fan stop.
4-Way valve (RVR)	OFF	ON	OFF
Solenoid valve (SVA) (Equalised pressure valve)	<ul style="list-style-type: none"> Turn ON at starting. Pd increase protection control. RAS-(4-12)H(V)N(P/C)(E)	<ul style="list-style-type: none"> Turn ON at starting. Pd increase protection control. RAS-(4-12)H(V)N(P/C)(E)	Turn ON at starting. RAS-(4-12)H(V)N(P/C)(E)
Solenoid valve (SVC) (Hot gas discharge bypass)	—	Turn ON depending on I.U. discharge / suction temperature, outdoor temperature, outdoor liquid temperature, etc. RAS-(3-12)H(V)N(P/C)(E)	—
Solenoid Valve (SVF) (Oil return)	Turn ON at compressor operation RAS-12HN(P/C)	Turn ON at compressor operation RAS-12HN(P/C)	Turn ON during defrosting RAS-12HN(P/C)
High/Low pressure balance	RAS-(2-2.5)HVNP / RAS-3HVNP(P/C)(E): Performed at the indoor expansion valve. RAS-(4-12)H(V)N(P/C)(E): Turn ON SVA during stop.	RAS-(2-2.5)HVNP / RAS-3HVNP(P/C)(E): Performed at the outdoor expansion valve. RAS-(4-12)H(V)N(P/C)(E): Turn ON SVA during stop.	—



NOTE

- **I.U.:** Indoor unit
- **O.U.:** Outdoor unit
- **Tc / Te:** Condensing temperature / Evaporating temperature
- **Td:** Discharge temperature
- **TI:** Liquid temperature
- **Tg:** Gas temperature
- **Cap:** Capacity
- **Temp.:** Temperature

The figure below shows the outline of the control system

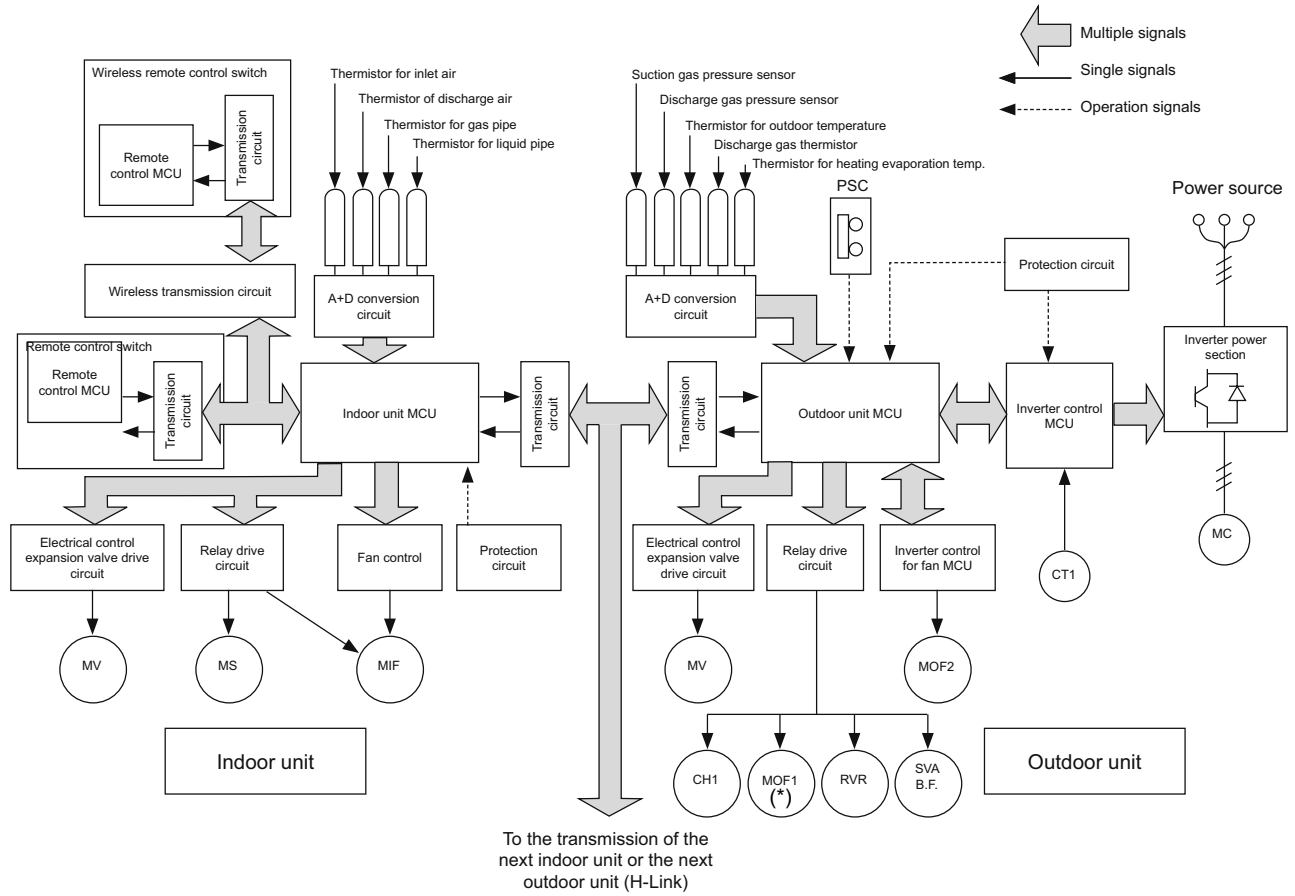

Symbol	Name	Symbol	Name
MC	Motor (for compressor)	CH	Crankcase heater
MIF	Motor (for indoor fan)	CT1	Current transformer
MOF1, 2	Motor (for outdoor fan)	RVR	4-Way valve
MS	Motor (for auto-louver)	SVA,B,F	Solenoid valve
MV	Electronic expansion valve	PSC	Pressure switch for control
CMC	Compressor magnetic contactor	EHW	Electric heater

(*) For RAS-12HN(P/C) models. Other than this, the two fan motors are controlled by the Inverter.

5.2 Outdoor units PCB

5.2.1 RAS-(2-2.5)HVNP / RAS-3HVNC

PCB1

PCB1

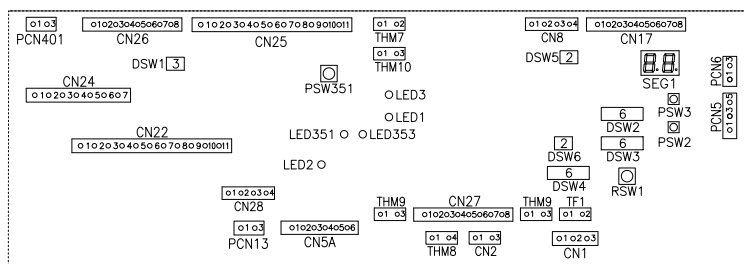

PCB2

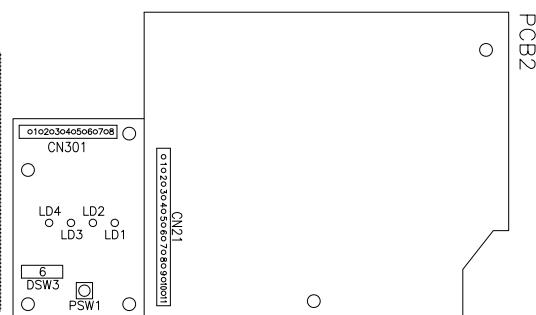

PCB1 Connector indication	
Connector	Name
PCN5	Crankcase heater of compressor (oil)
PCN6	Reversing valve relay
PCN13	Pressure switch control
PCN401	High pressure switch protection
THM7	Outdoor air temperature thermistor
THM8	Pipe evaporation temperature thermistor
THM9	Compressor discharge temperature thermistor
CN1	Input function
CN2	Demand input
CN5A	Micro electronic expansion valve
CN8	Transmission from outdoor unit to indoor unit
CN17	Transmission to PCB2
CN22	Transmission to IPM
CN24	Motor for outdoor fan
CN25	For inspection
CN26	For inspection

PCB1 Switch indication	
Connector	Name
DSW1	No setting
DSW2	Auxiliary function setting
DSW3	Capacity code
DSW4/ RSW1	Refrigerant cycle number
DSW5	Switch
DSW6	Switch
PSW2	Available optional function. Setting can be selected using the 7-segment display
PSW3	
PSW351	The inverter micro-computer checking

PCB1 LED indication		
LED	Colour	Name
LED1	Red	Power source for the PCB
LED2	Green	This LED indicates the transmission status between the indoor unit and the RCS
LED3	Yellow	This LED indicates the transmission status between the indoor unit and the outdoor unit
LED351	Red	For inspection
LED353	Red	For inspection

PCB2 Connector indication	
Connector	Name
CN21	Transmission to PCB1
CN301	Transmission to PCB1

PCB2 LED indication		
LED	Colour	Name
LED1	Red	These LEDs indicate the cause of unit stoppages
LED2	Red	
LED3	Red	
LED4	Red	

PCB2 Switch indication	
Connector	Name
DSW301	Test run
PSW1	Manual defrost operation switch. The defrost option is manually available under the forced defrost area

5.2.2 RAS-3HVNP

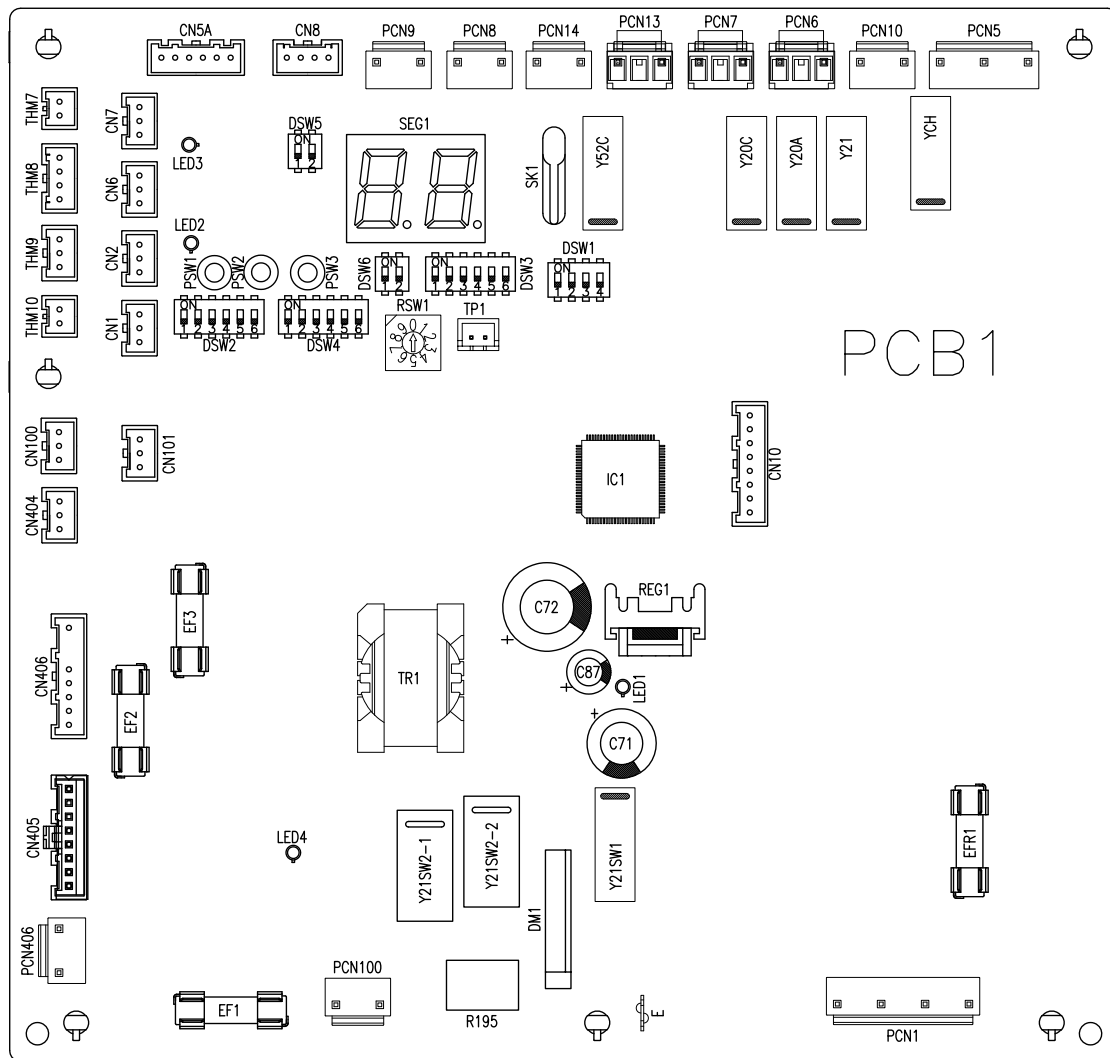

5

Connector indication

PCN1	Fuse
PCN5	Crankcase heater of compressor (oil)
PCN8	High pressure switch protection
PCN9	Compressor contactor
PCN10	Low pressure switch protection
PCN14	Solenoid valve
PCN100	4-way solenoid valve
PCN406	Power connection between PCB and DIP-IPM
THM7	Outdoor air temperature thermistor
THM8	Pipe evaporation temperature thermistor
THM9	Compressor discharge temperature thermistor
CN5A	Micro electronic expansion valve
CN6	Transmission between PCB and DIP-IPM
CN8	Transmission from outdoor to indoor unit
CN100	Discharge pressure (Pd)
CN404	Line connection between PCB and DIP-IPM
CN406	Motor for fan
EF1,2,3 EFR1	Power protection

Switch indication

DSW1	Test run
DSW2	Auxiliary function setting
DSW3	Capacity code
DSW4/ RSW1	Refrigerant cycle number
DSW5	Switch
DSW6	Switch

LED indication

LED1	Red	Power source for the PCB
LED2	Green	This LED indicates the transmission status between the indoor unit and the RCS
LED3	Yellow	This LED indicates the transmission status between the indoor unit and the outdoor unit
LED4	Red	Power source at 280V for the PCB

5.2.3 RAS-(4-6)H(V)NPE

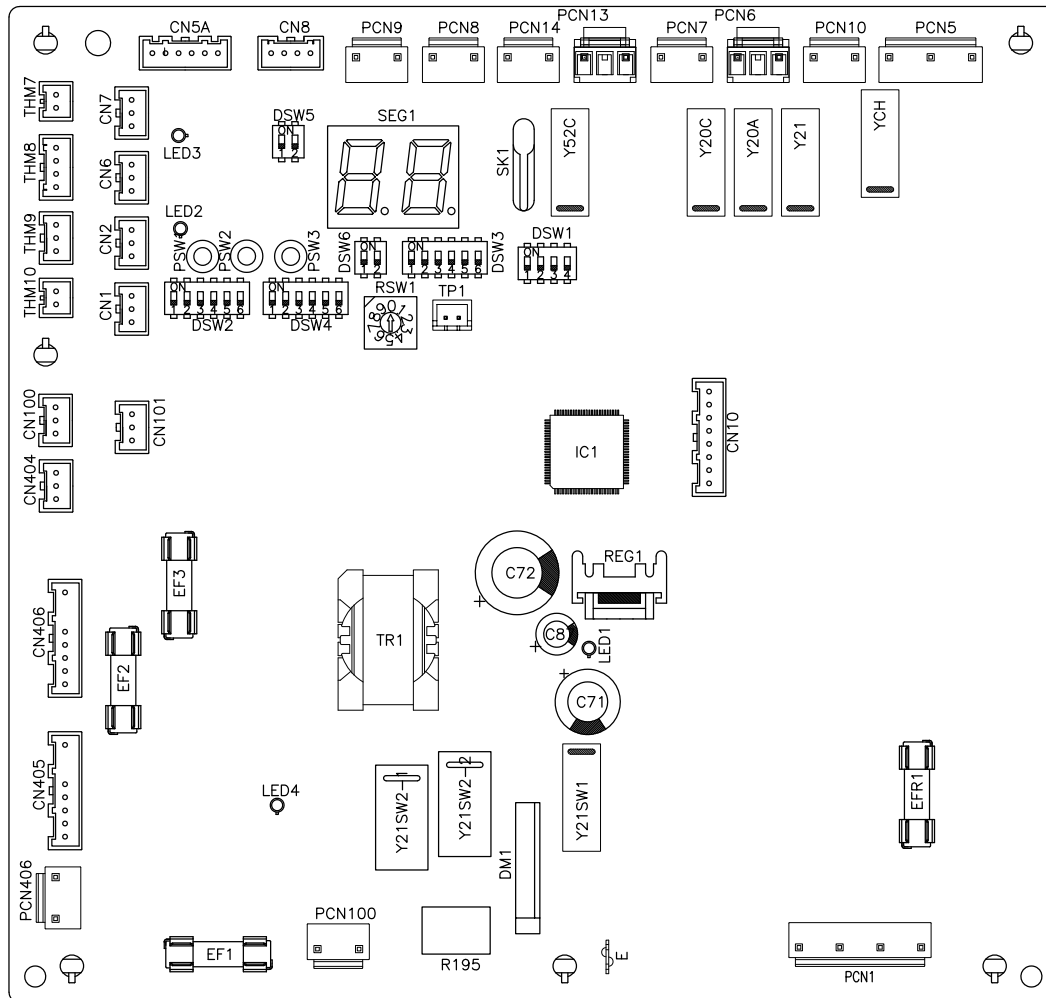

Connector indication	
PCN1	Fuse
PCN5	Crankcase heater of compressor (oil)
PCN7	Solenoid valve
PCN8	High pressure switch protection
PCN9	Compressor contactor
PCN10	Low pressure switch protection
PCN14	Solenoid valve
PCN100	4-way solenoid valve
PCN406	Power connection between PCB and DIP-IPM
THM7	Outdoor air temperature thermistor
THM8	Pipe evaporation temperature thermistor
THM9	Compressor discharge temperature thermistor
CN5A	Micro electronic expansion valve
CN6	Transmission between PCB and DIP-IPM
CN8	Transmission from outdoor to indoor unit
CN100	Discharge pressure (Pd)
CN404	Line connection between PCB and DIP-IPM
CN405	Motor for fan 2
CN406	Motor for fan 1
EF1,2,3	Power protection
EFR1	

Switch indication		
DSW1		Test run
DSW2		Auxiliary function setting
DSW3		Capacity code
DSW4/ RSW1		Refrigerant cycle number
DSW5		Switch
DSW6		Switch

LED indication		
LED1	Red	Power source for the PCB
LED2	Green	This LED indicates the transmission status between the indoor unit and the RCS
LED3	Yellow	This LED indicates the transmission status between the indoor unit and the outdoor unit
LED4	Red	Power source at 280V for the PCB

5.2.4 RAS-(4-6)H(V)NCE

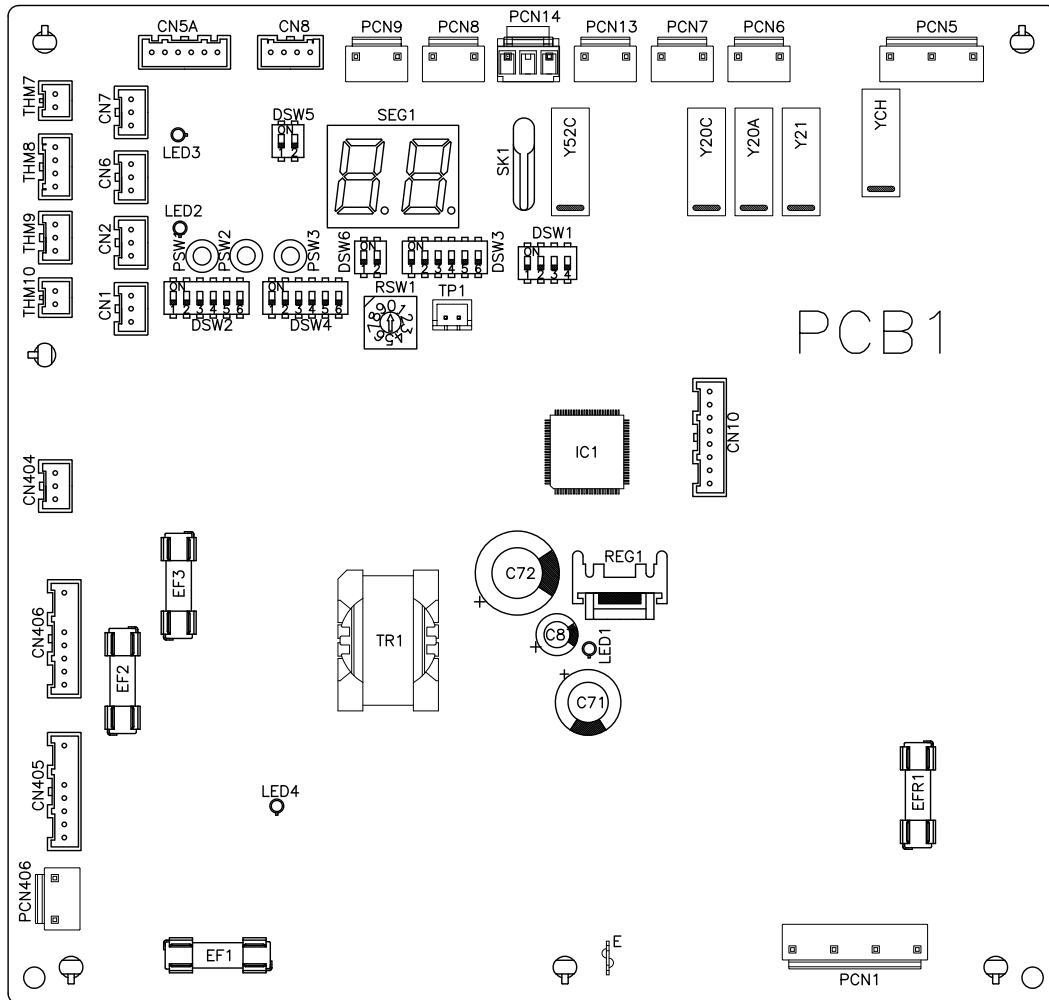

Connector indication	
PCN1	Fuse
PCN5	Crankcase heater of compressor (oil)
PCN6	4-way solenoid valve
PCN7	Solenoid valve
PCN8	High pressure switch protection
PCN9	Compressor contactor
PCN10	Low pressure switch protection
PCN13	Pressure switch control
PCN406	Power connection between PCB and DIP-IPM
THM7	Outdoor air temperature thermistor
THM8	Pipe evaporation temperature thermistor
THM9	Compressor discharge temperature thermistor
THM10	Compressor suction temperature thermistor
CN5A	Micro electronic expansion valve
CN6	Transmission between PCB and DIP-IPM
CN8	Transmission from outdoor to indoor unit
CN404	Line connection between PCB and DIP-IPM
CN406	Motor for fan
EF1,2,3 EFR1	Power protection

Switch indication	
DSW1	Test run
DSW2	Auxiliary function setting
DSW3	Capacity code
DSW4/ RSW1	Refrigerant cycle number
DSW5	Switch
DSW6	Switch

LED indication		
LED1	Red	Power source for the PCB
LED2	Green	This LED indicates the transmission status between the indoor unit and the RCS
LED3	Yellow	This LED indicates the transmission status between the indoor unit and the outdoor unit
LED4	Red	Power source at 280V for the PCB

5

5.2.5 RAS-(8-10)HN(P/C/E)

PCB1

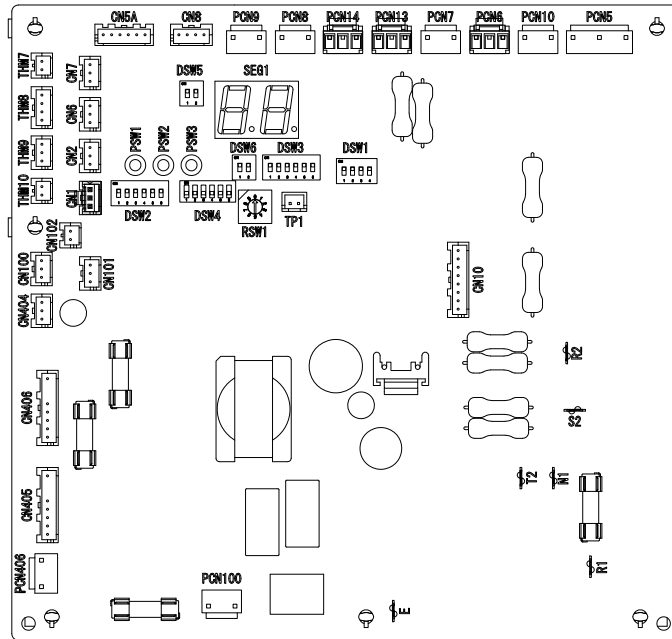

PCB3

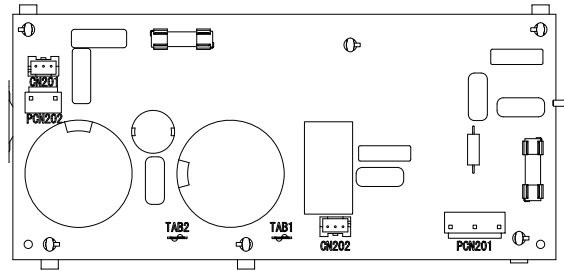

PCB1 Connector indication

Connector	Name
PCN1	Fuse
PCN5	Crankcase heater of compressor (oil)
PCN7	Solenoid valve
PCN8	High pressure switch protection
PCN9	Compressor contactor
PCN10	Low pressure switch protection
PCN14	Solenoid valve (only RAS-(8-10)HNPE)
PCN100	4-way solenoid valve
PCN406	Power connection between PCB1 and PCB3
THM7	Outdoor air temperature thermistor
THM8	Pipe evaporation temperature thermistor
THM9	Compressor discharge temperature thermistor
CN5A	Micro electronic expansion valve
CN6	Transmission between PCB1 and DIP-IPM
CN8	Transmission from outdoor to indoor unit
CN100	Discharge pressure (Pd)
CN102	Line connection between PCB1 and PCB3
CN404	Line connection between PCB1 and PCB3
CN405	Motor for fan 2
CN406	Motor for fan 1
EF1,2,3	Power protection
EFR1	

PCB1 Switch indication

Connector	Name
DSW1	Test run
DSW2	Auxiliary function setting
DSW3	Capacity code
DSW4/ RSW1	Refrigerant cycle number
DSW5	Switch
DSW6	Switch

PCB1 LED indication

LED	Colour	Name
LED1	Red	Power source for the PCB
LED2	Green	This LED indicates the transmission status between the indoor unit and the RCS
LED3	Yellow	This LED indicates the transmission status between the indoor unit and the outdoor unit
LED4	Red	Power source at 280V for the PCB

PCB3 Connector indication

Connector	Name
PCN201	Fuse
PCN202	Power connection between PCB3 and PCB1
CN201	Line connection between PCB3 and PCB1
CN202	Line connection between PCB3 and PCB1
EFR1	Power protection

5.2.6 RAS-12HNP - Preliminary data

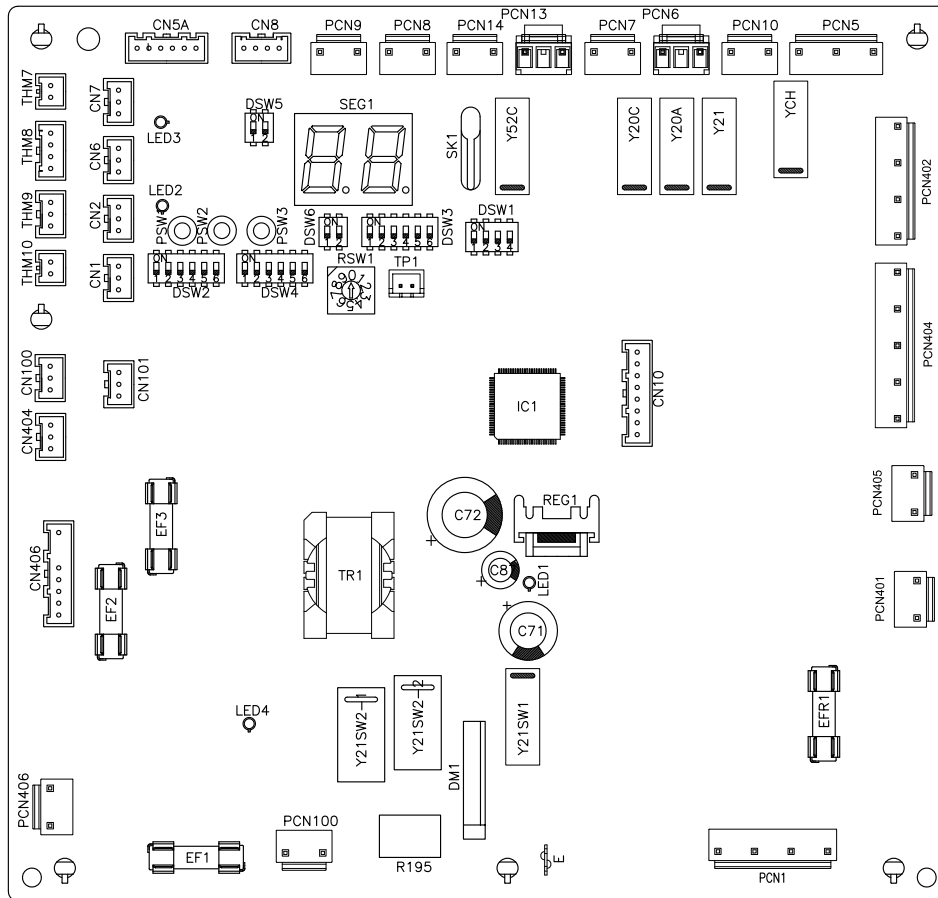

5

Connector indication

PCN1	Fuse
PCN5	Crankcase heater of compressor (oil)
PCN7	Solenoid valve
PCN8	High pressure switch protection
PCN9	Compressor contactor
PCN10	Low pressure switch protection
PCN14	Solenoid valve
PCN100	4-way solenoid valve
PCN401	Fuse
PCN402	Solenoid valve
PCN404	Motor for fan 2
PCN405	Capacitor
PCN406	Power connection between PCB and DIP-IPM
THM7	Outdoor air temperature thermistor
THM8	Pipe evaporation temperature thermistor
THM9	Compressor discharge temperature thermistor
CN5A	Micro electronic expansion valve
CN6	Transmission between PCB and DIP-IPM
CN8	Transmission from outdoor to indoor unit
CN100	Discharge pressure (Pd)
CN404	Line connection between PCB and DIP-IPM
CN406	Motor for fan 1
EF1,3 EFR1,2	Power protection

Switch indication

DSW1	Test run
DSW2	Auxiliary function setting
DSW3	Capacity code
DSW4/ RSW1	Refrigerant cycle number
DSW5	Switch
DSW6	Switch

LED indication

LED1	Red	Power source for the PCB
LED2	Green	This LED indicates the transmission status between the indoor unit and the RCS
LED3	Yellow	This LED indicates the transmission status between the indoor unit and the outdoor unit
LED4	Red	Power source at 280V for the PCB

5.2.7 RAS-12HNC - Preliminary data

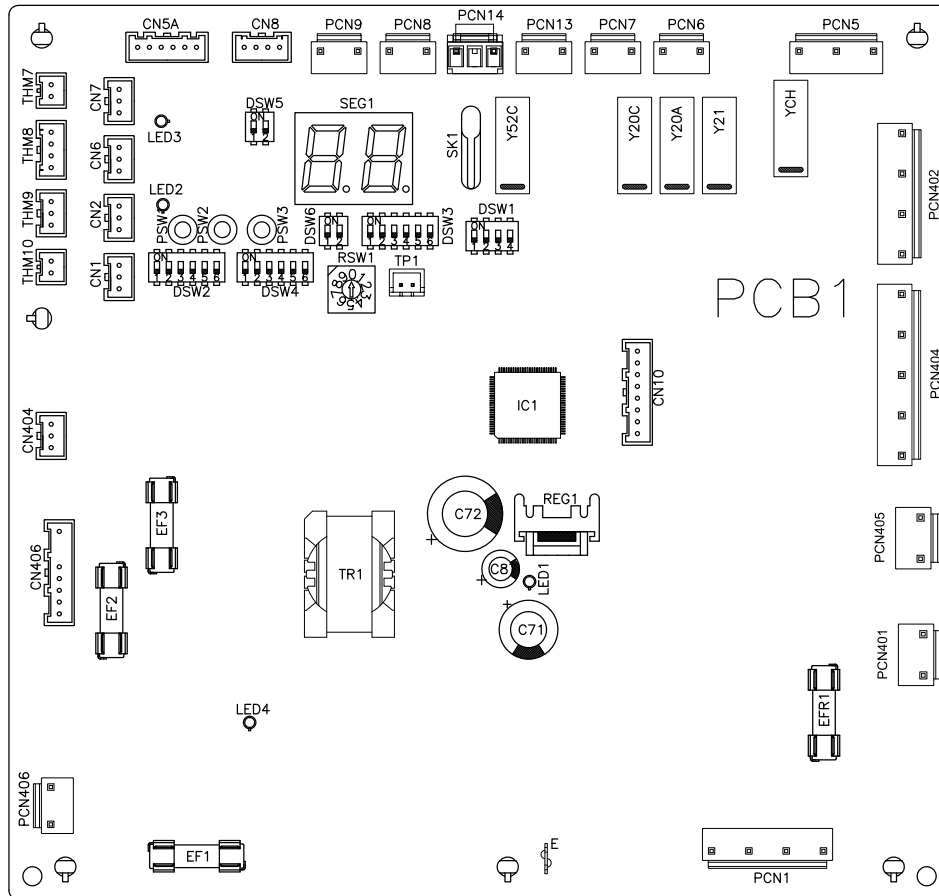

Connector indication

PCN1	Fuse
PCN5	Crankcase heater of compressor (oil)
PCN6	4-way solenoid valve
PCN7	Solenoid valve
PCN8	High pressure switch protection
PCN9	Compressor contactor
PCN10	Low pressure switch protection
PCN13	Pressure switch control
PCN401	Fuse
PCN402	Solenoid valve
PCN404	Motor for fan 2
PCN405	Capacitor
PCN406	Power connection between PCB and DIP-IPM
THM7	Outdoor air temperature thermistor
THM8	Pipe evaporation temperature thermistor
THM9	Compressor discharge temperature thermistor
THM10	Compressor suction temperature thermistor
CN5A	Micro electronic expansion valve
CN6	Transmission between PCB and DIP-IPM
CN8	Transmission from outdoor to indoor unit
CN404	Line connection between PCB and DIP-IPM
CN406	Motor for fan 1
EF1,2,3 EFR1	Power protection

Switch indication

DSW1	Test run
DSW2	Auxiliary function setting
DSW3	Capacity code
DSW4/ RSW1	Refrigerant cycle number
DSW5	Switch
DSW6	Switch

LED indication

LED1	Red	Power source for the PCB
LED2	Green	This LED indicates the transmission status between the indoor unit and the RCS
LED3	Yellow	This LED indicates the transmission status between the indoor unit and the outdoor unit
LED4	Red	Power source at 280V for the PCB

5.3 Protection and safety control

◆ Compressor protection

The following devices and their combinations protect the compressor

High-pressure switch	This switch cuts out the operation of the compressor when the discharge pressure exceeds the setting.
Oil heater	This band heater protects against the oil carry-over during the cold starting, as the band heater is energized while the compressor is stopped.
Fan motor protection	Internal thermostat that is embedded in the fan motor winding: this internal thermostat cuts out the operation of the fan motor when the temperature of the fan motor winding exceeds the setting. (only for some RPI models)

◆ Safety and control device setting for the outdoor units

		Model	RAS-(2-2.5)HVNP RAS-3HVNC	RAS-3HVNPE	RAS-(4-6)HVN(P/C)E	RAS-(4-12)HN(P/C)(E)	
For compressor	Pressure Switches		Automatic Reset, Non-Adjustable (each one for each compressor)				
	High	Cut-Out	MPa	-0.05 4.15	-0.05 4.15	-0.05 4.15	-0.05 4.15
		Cut-In	MPa	-0.15 3.20±0.15	-0.15 3.20±0.15	-0.15 3.20±0.15	-0.15 3.20±0.15
For fuse control	1~ 230V 50Hz	A	25	40	50 (RAS-4HVNCE = 40)		
	3N~ 400V 50Hz	A				2 X 20	
CCP Timer		min.	Non-Adjustable				
Setting Time			3	3	3	3	
Discharge gas Thermistor		°C	115 (OFF) Cooling 115 (OFF) Heating	115 (OFF) Cooling 115 (OFF) Heating	127 (OFF) Cooling 120 (OFF) Heating	127 (OFF) Cooling 120 (OFF) Heating	
For Condenser Fan Motor		Cut-Out	Automatic Reset, Non-Adjustable (each one for each motor)				
Internal Thermostat			°C	-	120	120	120
For Control Circuit		A	3	5	5	5	
Fuse Capacity on PCB							

5

5.4 Standard operation sequence

5.4.1 Cooling operation

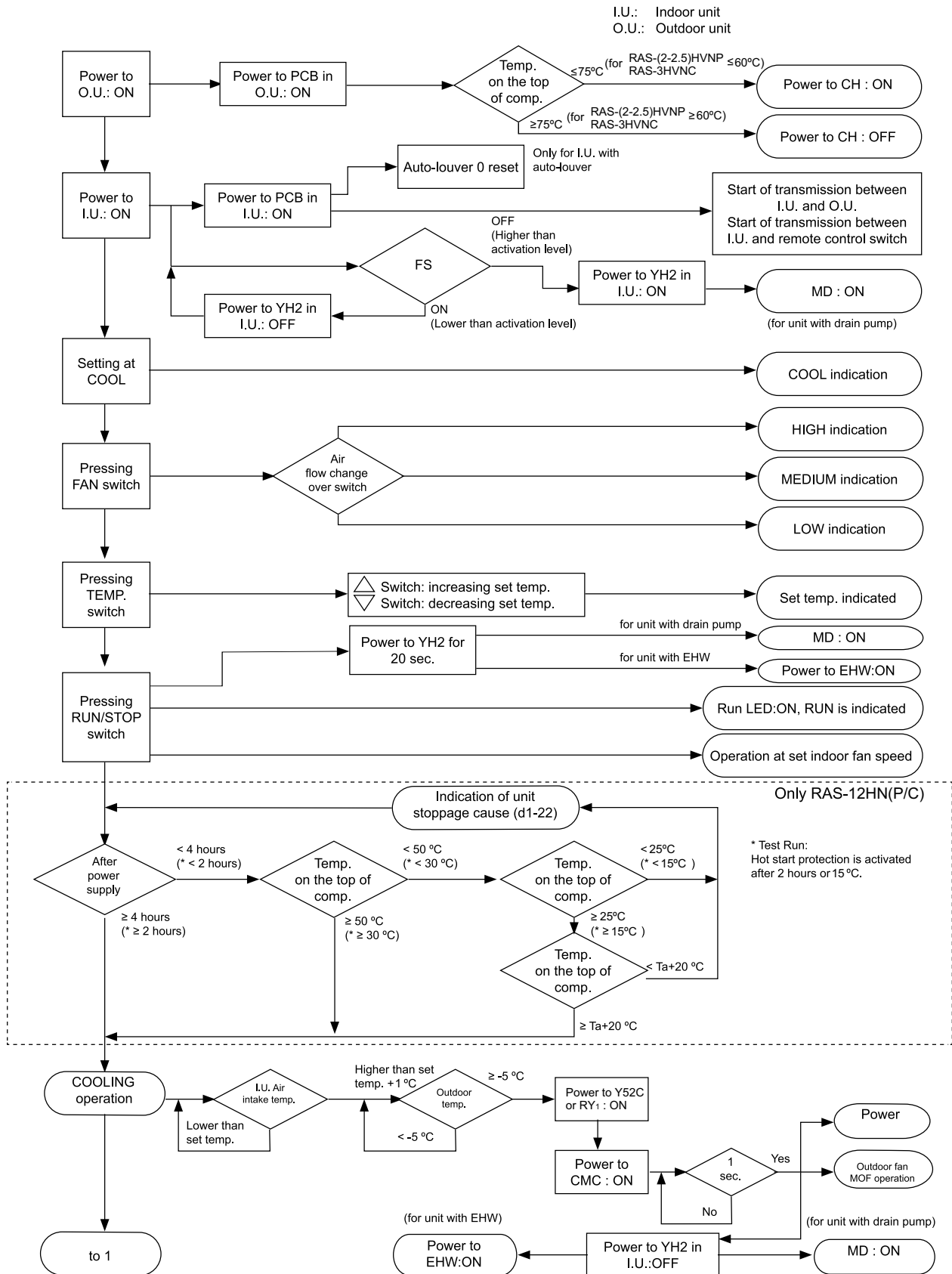

Continues in the next page.

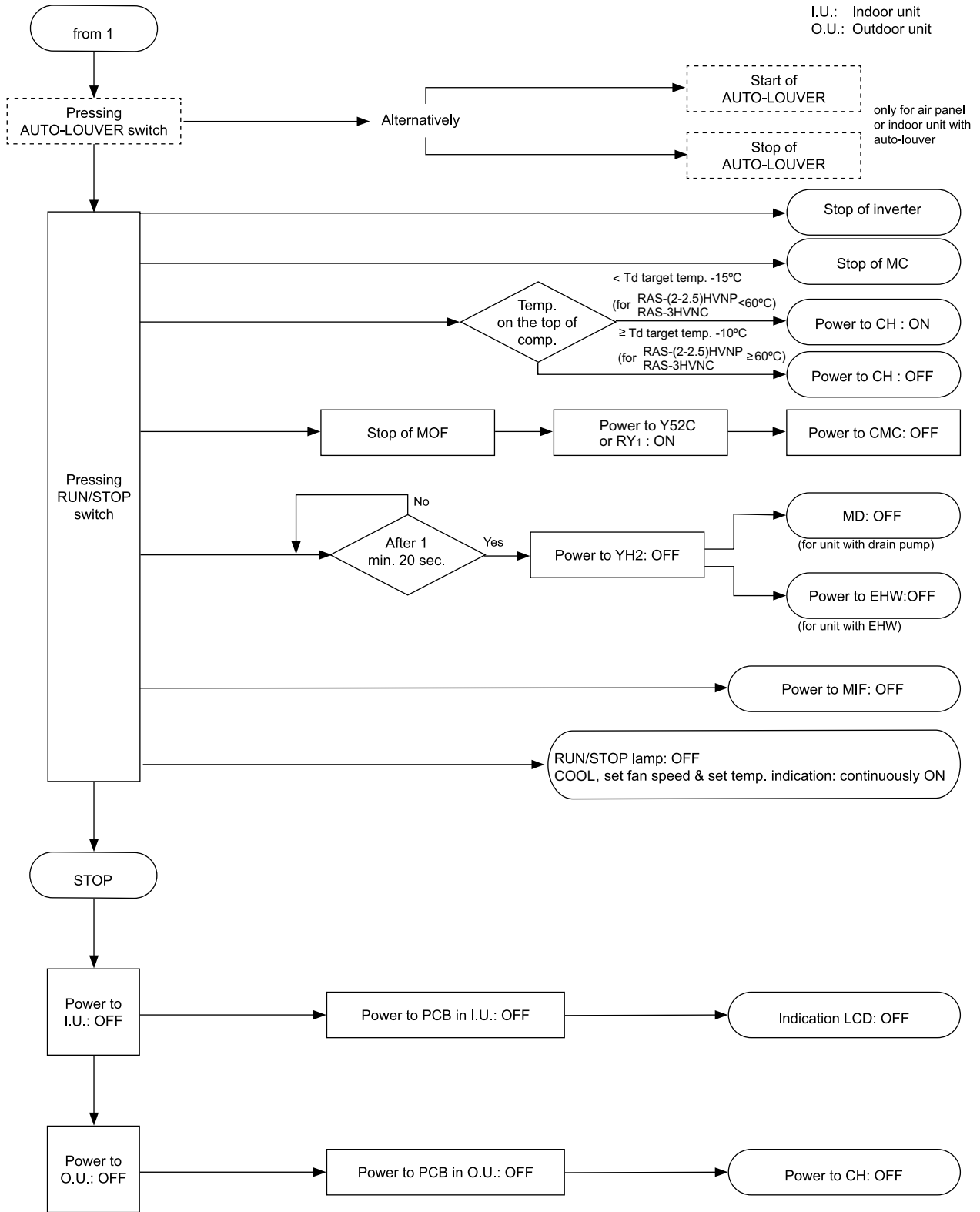

5.4.2 Dry operation

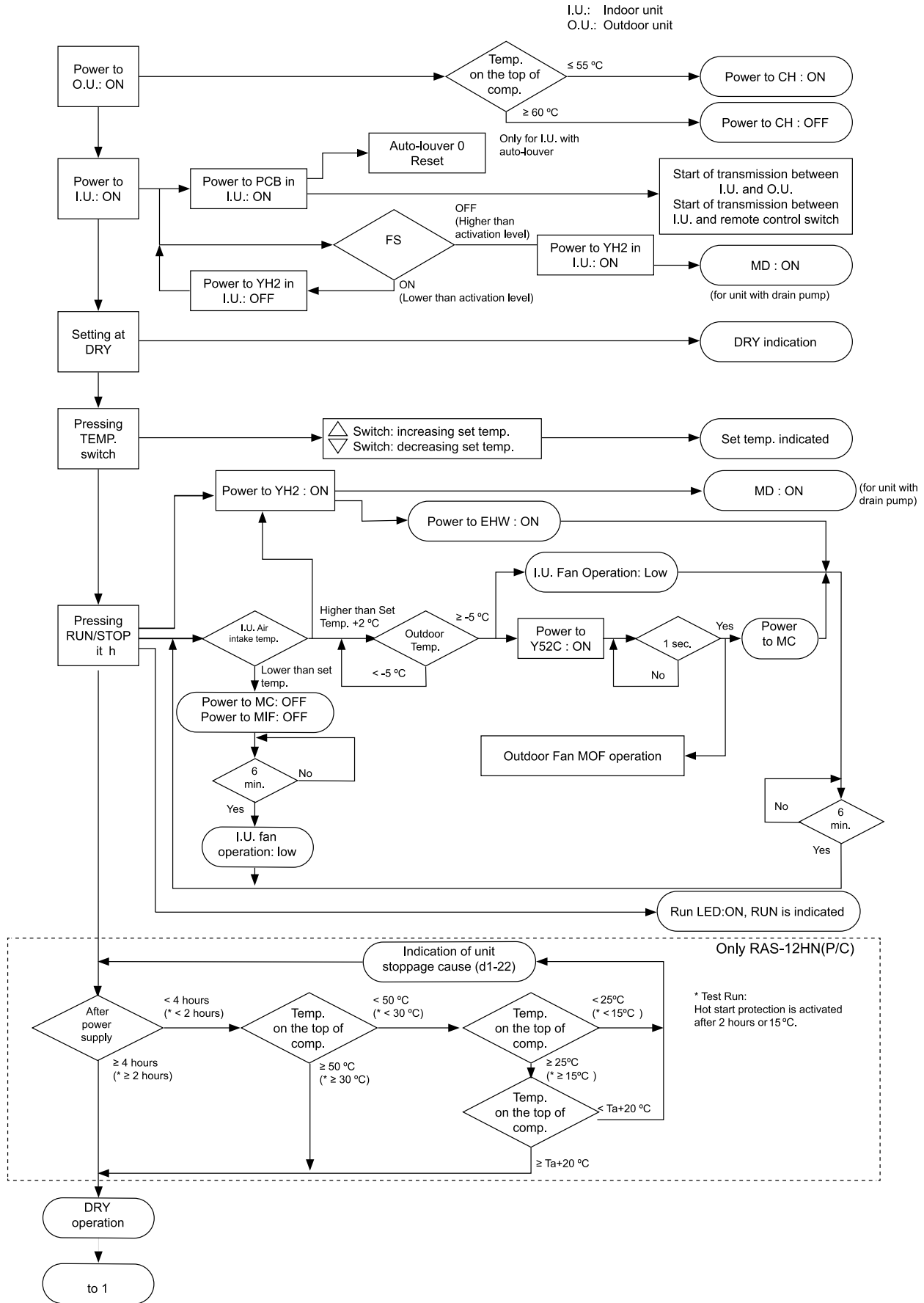

Continues in the next page.

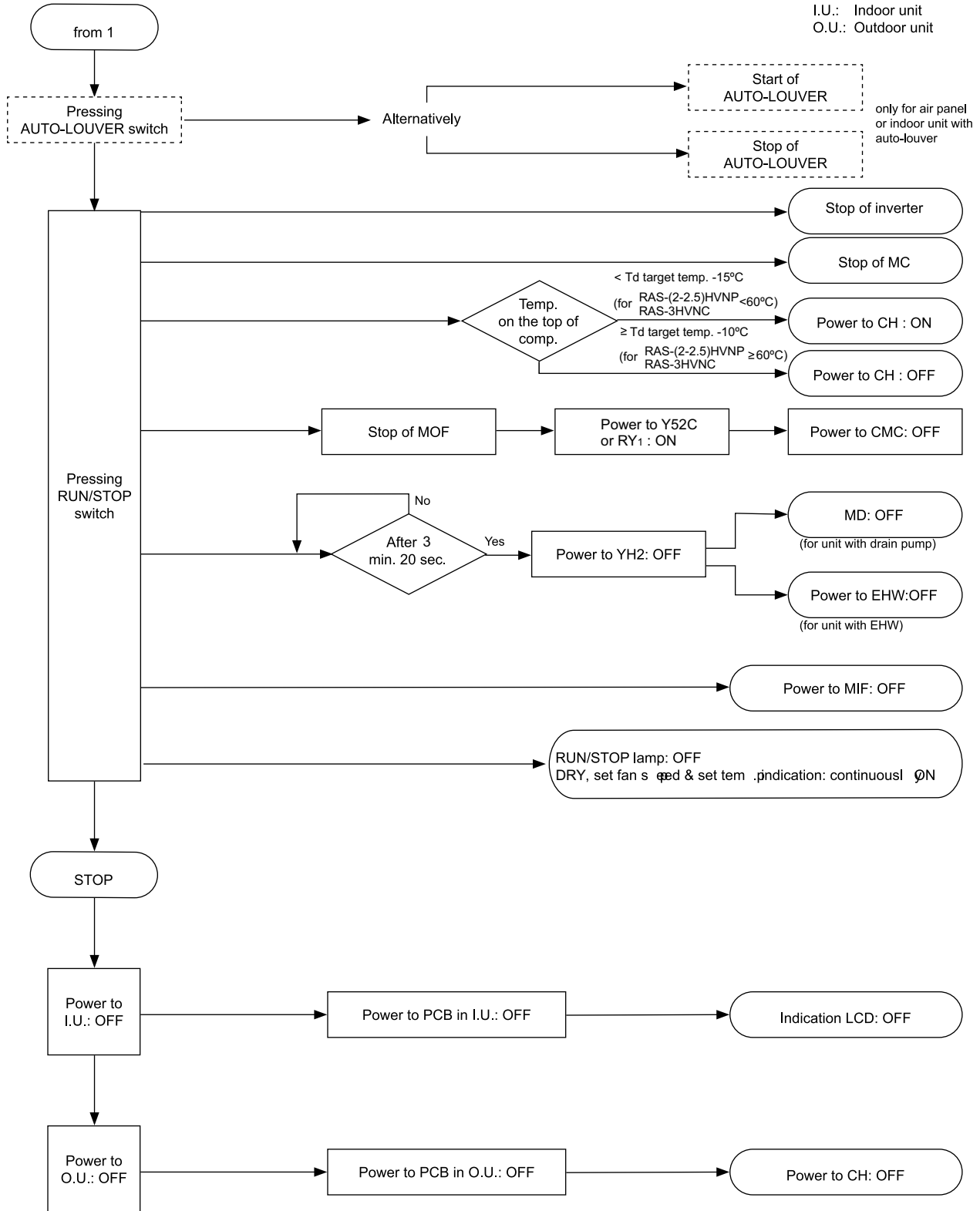

5.4.3 Heating operation

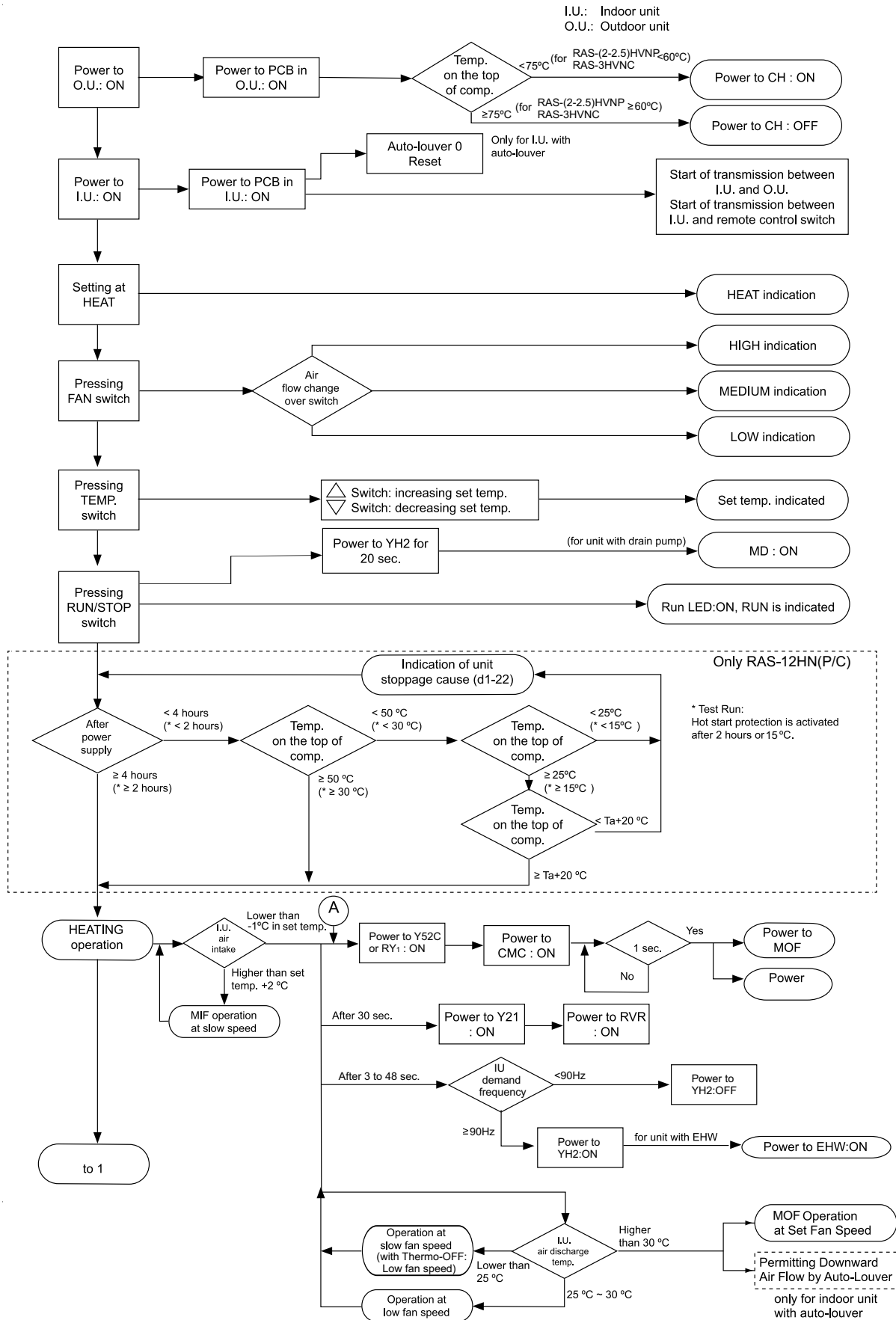

Continues in the next page.

I.U.: Indoor unit
O.U.: Outdoor unit

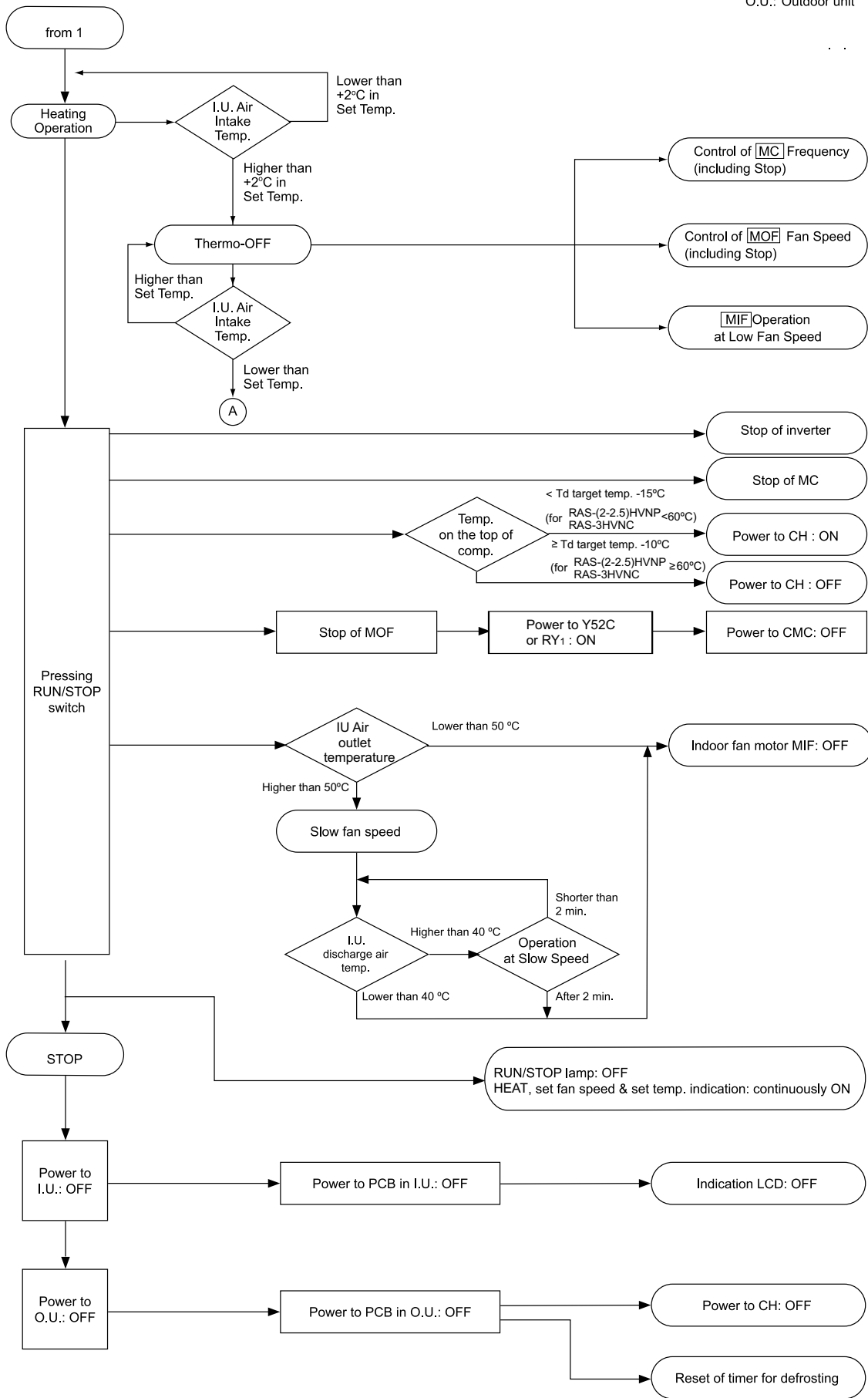

5

5.4.4 Automatic cooling and heating operation

I.U.: Indoor Unit

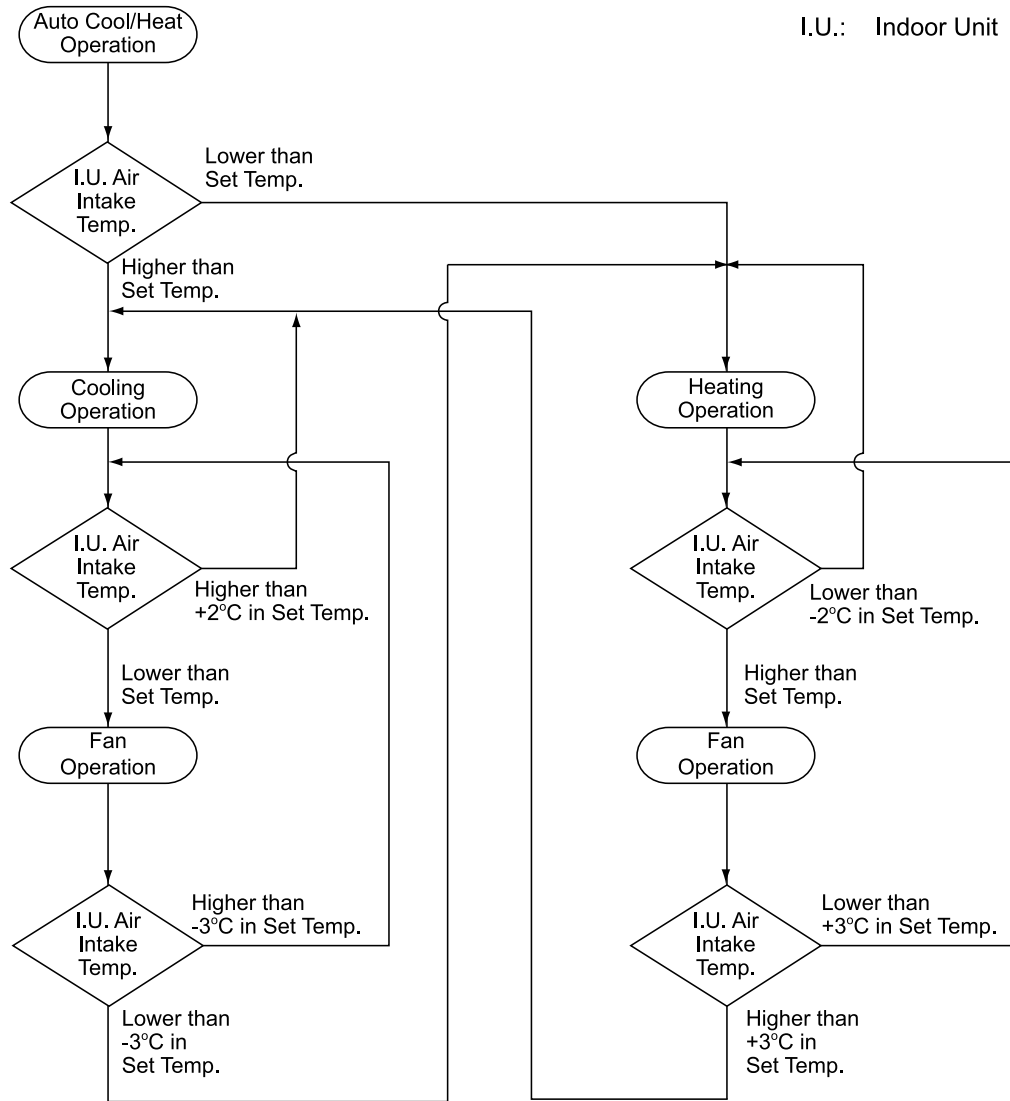

5.4.5 Defrost operation control

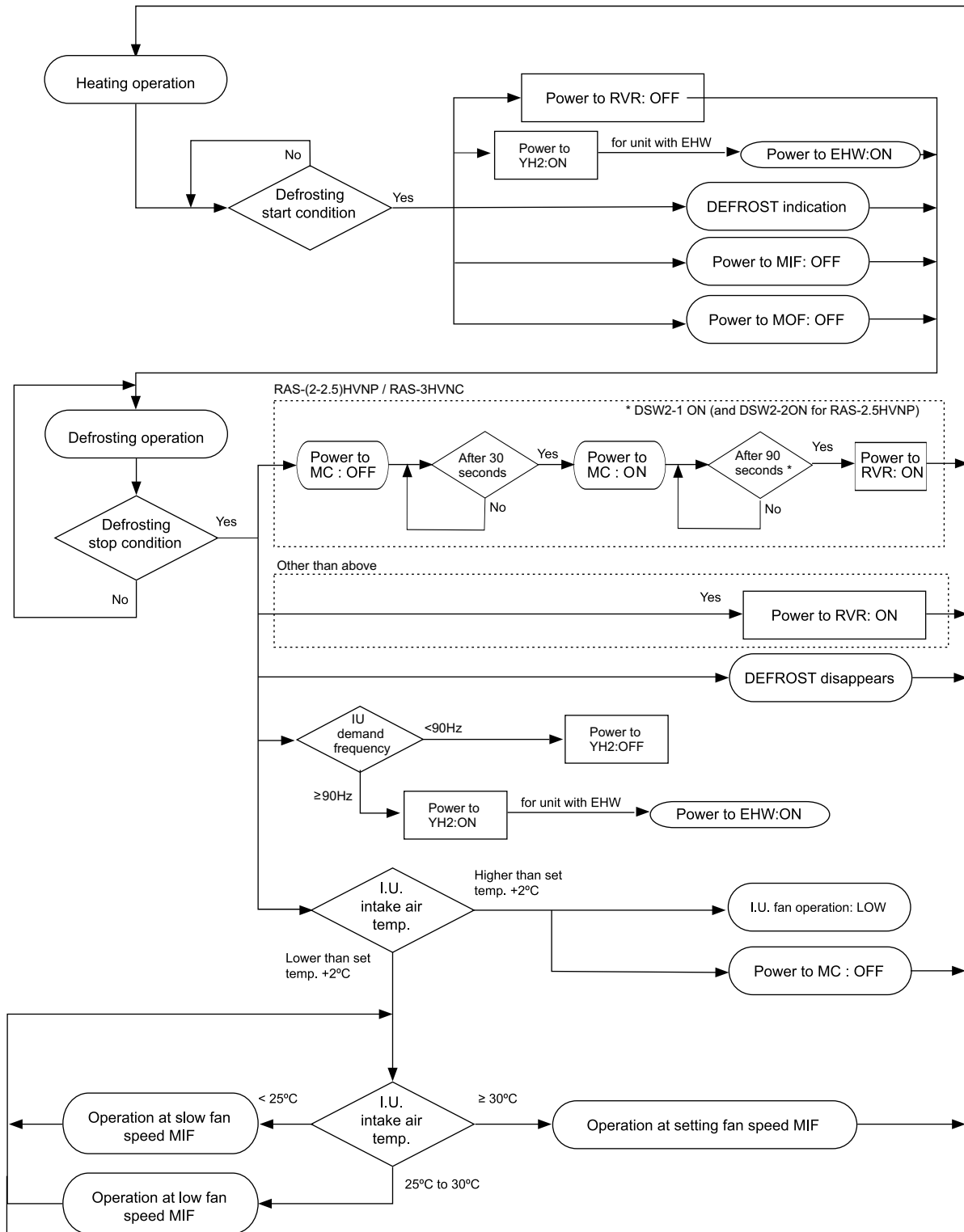

◆ Defrosting Operation

The following defrosting operations, “Standard Defrost”, “Forced Defrost” and “Manual Defrost” are available.

1 Standard Defrost

This operation is started according to the outdoor temperature, the outdoor evaporating temperature and operating time.

2 Forced Defrost

This operation starts when the indoor unit is operated Thermo-ON/OFF repeatedly and the standard defrost is not used.

3 Manual Defrost

This operation starts when the push switch “PSW1” on the outdoor PCB is pressed and hold for more than 3 seconds during the maintenance work. (It is not performed when the defrosting operation is started, the high pressure and the outdoor evaporating temperature is high.)



NOTE

Do not repeat defrost operation frequently.

◆ Condition for Starting Defrost

1 Standard Defrost

a. Temperature Condition

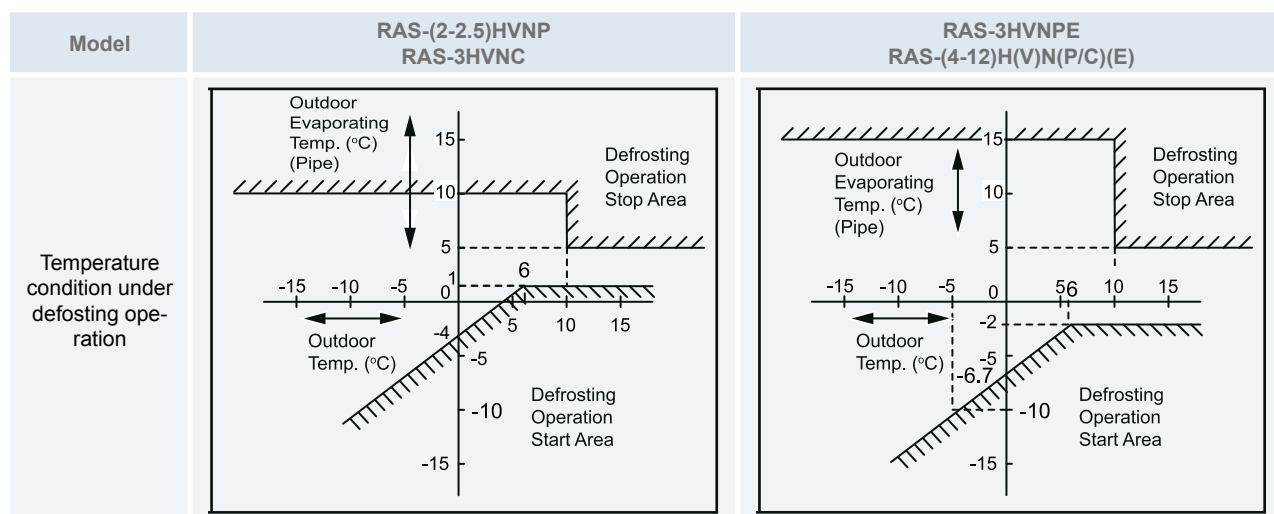

b. Condition for Operating Time of Defrost Operation Start

The defrosting operation is started when the temperature condition is met “(a) Temperature Condition” after the heating operation is performed for 40 to 120 minutes. The heating operation time is determined by estimating the amount of frosting on the heat exchanger.

2 Forced Defrost

Condition for Starting

The forced defrosting operation is started when all the following conditions are met.

- 120 minutes are passed after the reversing valve is “ON”.
- The outdoor temperature is lower than 10°C.
- The accumulated heating operation time is more than 60 minutes. (*1)
(The accumulated time is reset when the operation is stopped or the defrosting operation is performed.)
- The compressor is operated continuously for more than 1 and half minutes. (*2)
- The outdoor evaporating temperature is lower than 5°C (*3) right before starting the operation.
- The pressure switch for control is “OFF”.

**NOTE**

For RAS-(2-2.5)HVNP / RAS-3HVNC:

- *(*1) More than 39 minutes.*
- *(*2) If outdoor temperature is less than -6°C then the compressor is operated continuously for more than 2 minutes. If outdoor temperature is more than -6°C then the compressor is operated continuously for more than 9 minutes.*
- *(*3) Less than 6°C.*

◆ Condition for Completing Defrost Operation

The defrosting operation is stopped when any of following conditions are met.

- 1 The outdoor evaporating temperature becomes more than 25°C (*1) for 2 minutes from starting the defrosting operation.
- 2 The outdoor evaporating temperature becomes more than 15°C (*2) (the outdoor temperature < 10°C) after passing 2 minutes from starting the defrosting operation.
- 3 The outdoor evaporating temperature becomes more than 5°C (the outdoor temperature ≥ 10°C) after passing 2 minutes from starting the defrosting operation.
- 4 The pressure switch for control is "ON".
- 5 More than 9 minutes (*3) are passed after starting the defrosting operation.

**NOTE**

For RAS-(2-2.5)HVNP / RAS-3HVNC:

- *(*1) More than 20°C.*
- *(*2) More than 10°C*
- *(*3) More than 10 minutes.*

**NOTE**

- *The defrosting operation is not started immediately even if the above conditions are met. (The defrosting condition may be met temporally depending on the refrigerant cycle variability.)*
- *The defrosting operation is started when the conditions are met continuously for period of time.*

5.5 Standard control functions

5.5.1 Freezing protection during cooling process or dry operation

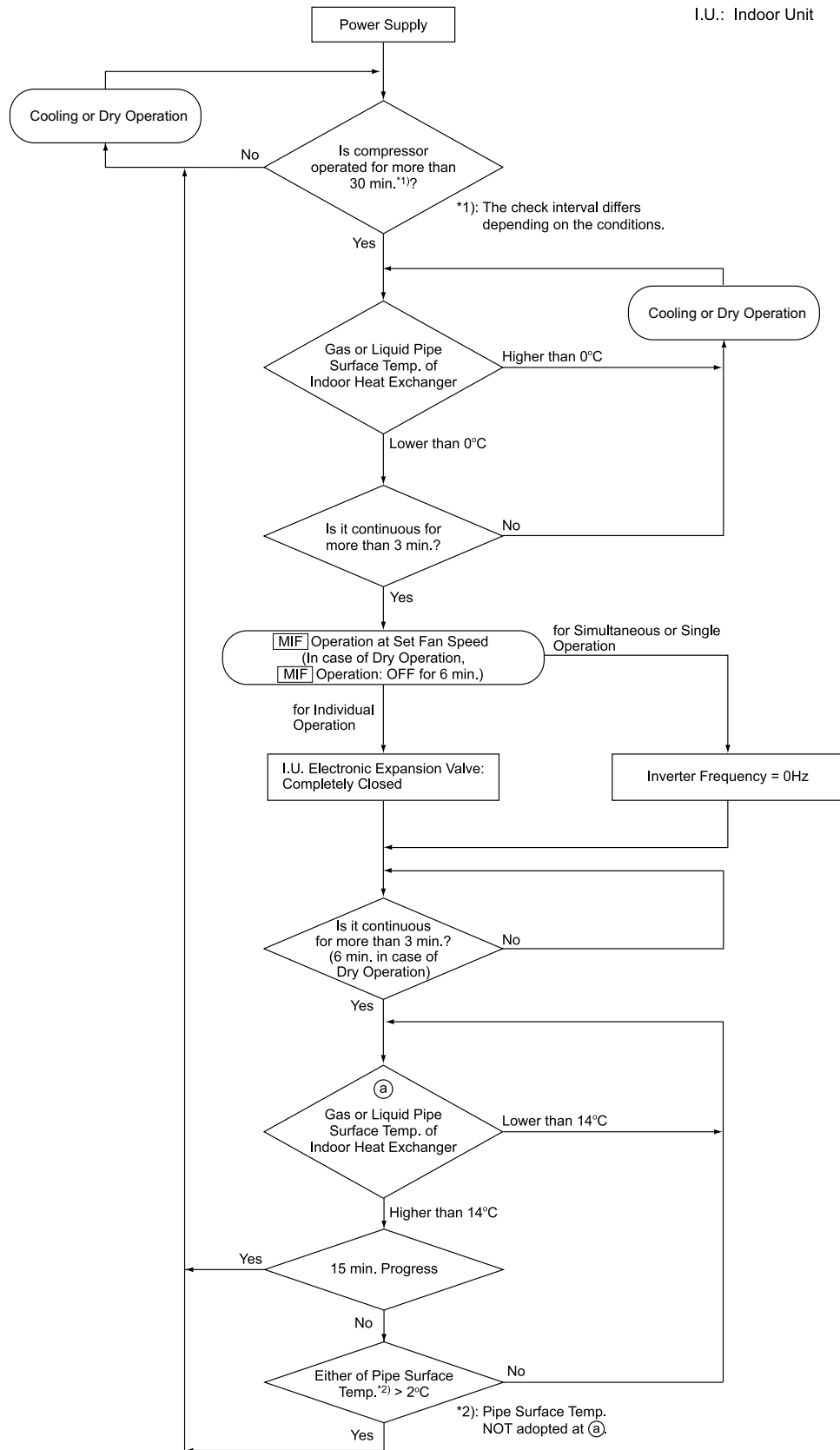

5.5.2 Prevention Control for High Pressure Increase during Cooling Operation

This function is performed to prevent the abnormal condition (Alarm Code: 02) when the air flow volume is decreased by a seasonal wind against air outlet of the outdoor unit. When the following conditions are met, the forced Thermo-OFF operation will be performed.

The cause of stoppage will be 13 during Thermo-OFF.

RAS-(2-2.5)HVNP / RAS-3HVNC

- 1 Y52C is turned "ON" during the cooling operation, or RY1 is turned "ON" (during the compressor operation).
- 2 Pressure switch for control is turned "ON".

ON	3.6MPa
OFF	2.85MPa

- 3 Outdoor liquid pipe temperature $\geq 55^{\circ}\text{C}$

RAS-(4-12)H(V)NC(E)

- 1 Y52C is turned "ON" during the cooling operation, or RY1 is turned "ON" (during the compressor operation).
- 2 Pressure switch for control is turned "ON".

ON	3.6MPa
OFF	2.85MPa

- 3 Condensation temperature $\geq 62^{\circ}\text{C}$

RAS-(3-12)H(V)NP(E)

- 1 Y52C is turned "ON" during the cooling operation, or RY1 is turned "ON" (during the compressor operation).
- 2 High Pressure $\geq 3.8\text{MPa}$

5.5.3 Prevention control for excessively high discharge gas temperature

I.U.: Indoor Unit

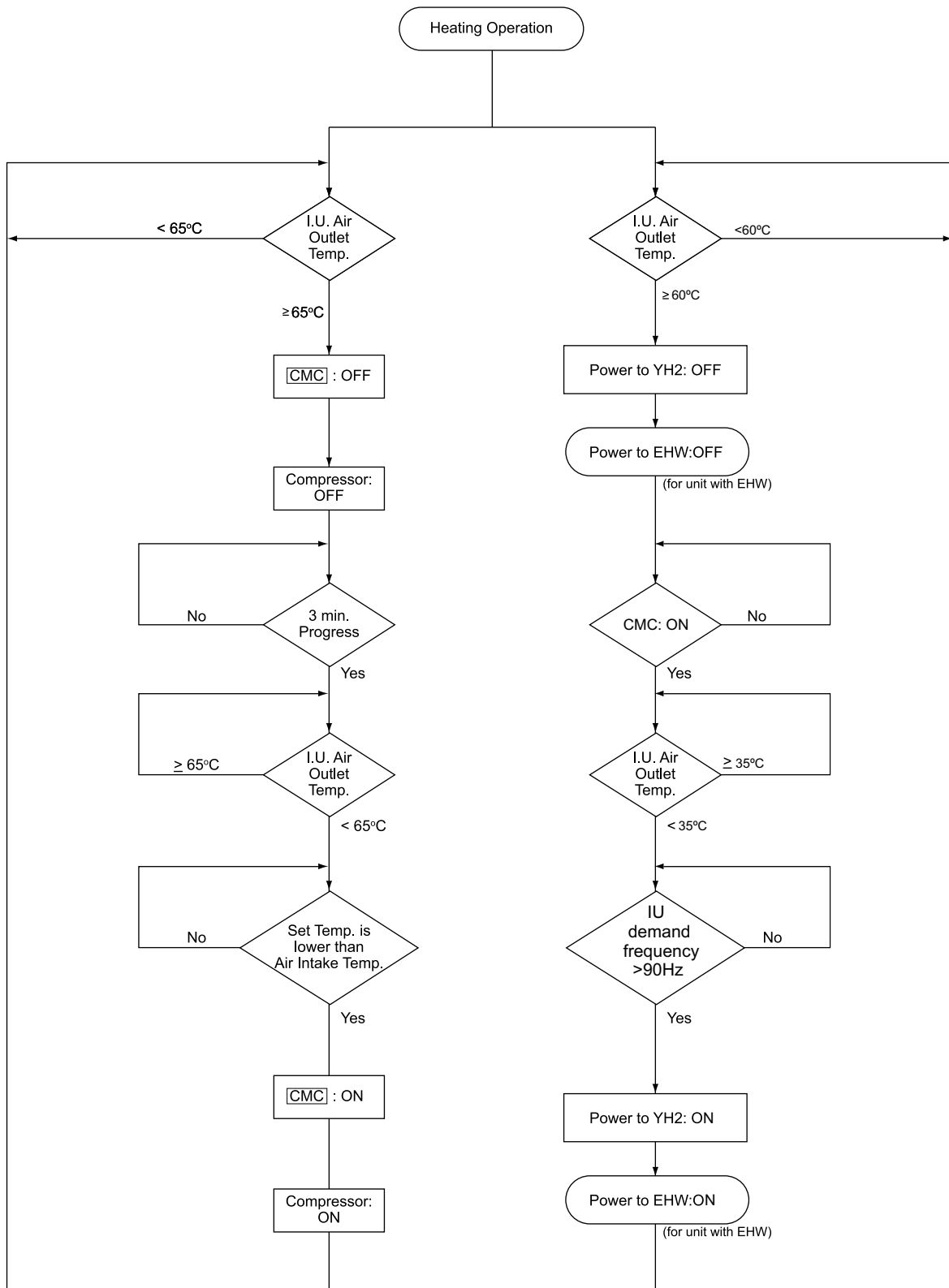

Thermo-ON/OFF Control for Indoor Unit

Heater control for Indoor Unit

5.5.4 Activation for protection device control

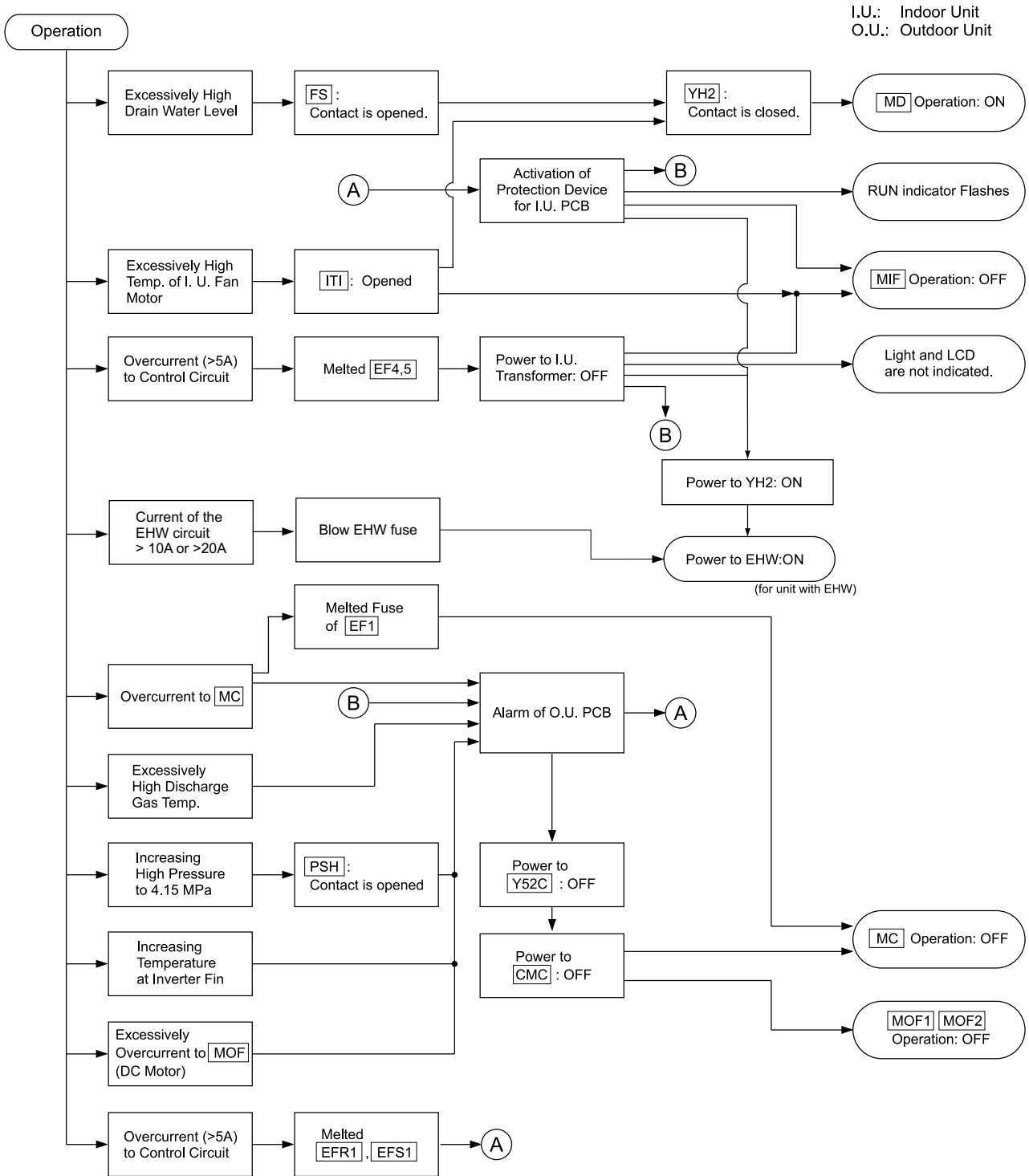

5.5.5 Preheating control of compressor

RAS-(2-2.5)HVNP / RAS-3HVNC

During stopping and operating compressor

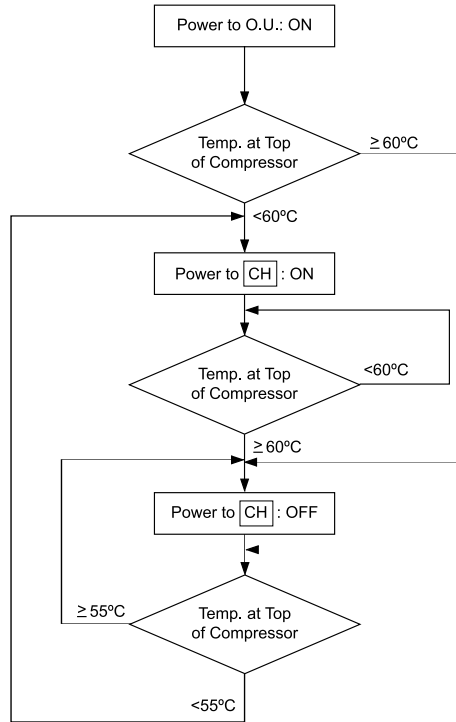

Other than above

During stopping compressor

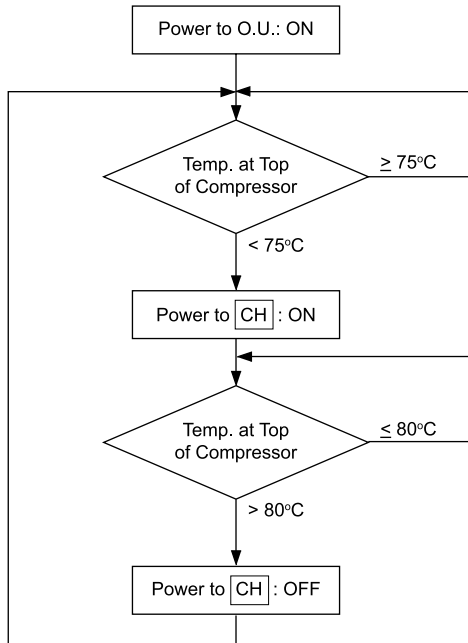

During operating compressor

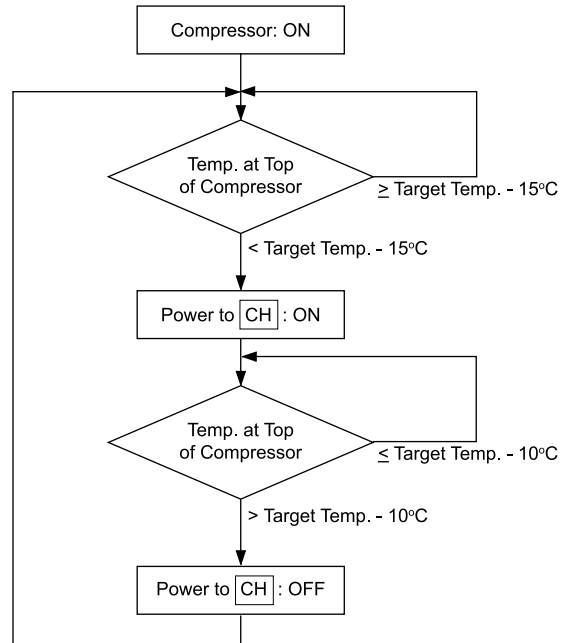

5.5.6 Prevention control for high pressure increase

This function is performed to prevent the abnormal condition (Alarm: 02) when the outdoor air flow is decreased by a seasonal wind against air outlet.

When the **CMC** is ON during cooling operation, **PSC** is ON and T_c is higher than $T_{c1}+4$ °C, forced thermo-off operation will be performed.

T_c : Outdoor piping temperature.

T_{c1} : Outdoor piping temperature when **PSC** is ON.

PSC ON: 3.60 MPa.

However, if it occurs more than 6 times during operation, forced thermo-off operation will not be performed. Cause of stop-page will be 13.

6 . Optional functions

Index

6.1. Optional input and output signals (By 7-segment display)	146
6.1.1. Available ports	146
6.1.2. Available optional signals	148
6.1.3. Setting of the optional signals	150
6.1.4. Description of optional signals	151
6.2. Optional functions (By 7-segment display)	154
6.2.1. Setting of the optional functions	154
6.2.2. Description of the optional functions	157
6.3. Optional functions (By remote control switch)	161

6.1 Optional input and output signals (By 7-segment display)

The system has several input and output signals, which can be selected using the following connectors of the outdoor unit's PCB:

- Input connectors CN1 and CN2, which have two and one ports respectively to configure three optional input signals.
- Output connector CN1, which has two ports to configure two optional output signals.

The selection of these input and output signals represent the selection of some optional functions programmed in the PCB of the outdoor unit.

6.1.1 Available ports

The system has the following input and output ports.

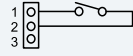
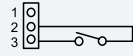
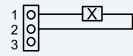
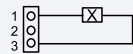
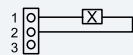
Content	Setting of the port in the PCB of the indoor unit	Remarks	Outlet	
Inputs	i1	1-2 of CN1		Contact
	i2	2-3 of CN1		Contact
	i3	1-2 of CN2		Contact
Outputs	o1	1-2 of CN7		DC 12V
	o2	1-3 of CN7		DC 12V

◆ Connection

The system has the following connections:

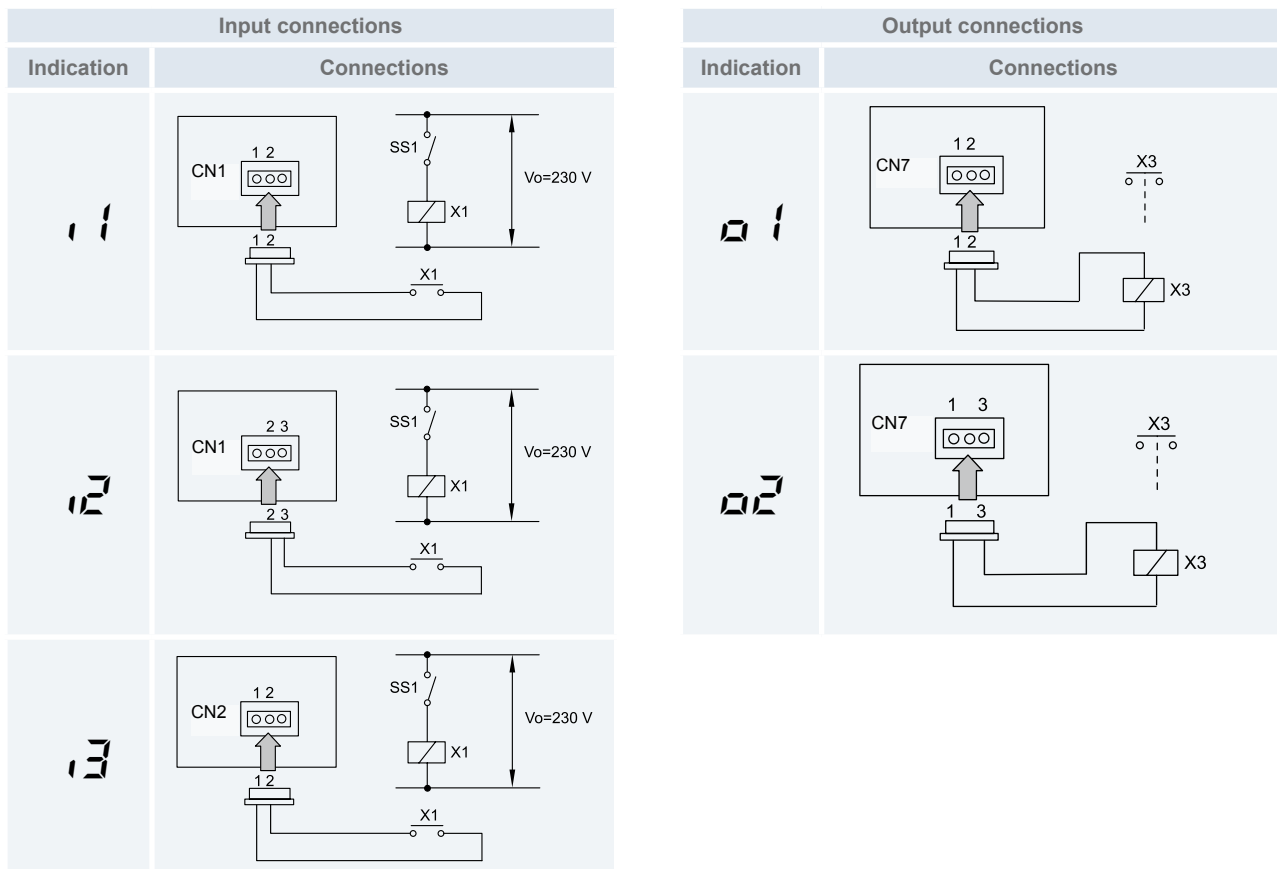

◆ Specification of the components for a correct installation

Component		Manufacturer or specifications	Remarks
Auxiliary relay (X3)		OMRON mini power relay model: MY1F or equivalent	Voltage between relay terminals 12 Vdc - 75 mA
(SS1) (x1), (x2) contact example		Manual type	Voltage between terminals of the 230V - 5 mA contactor
3P connector cable		Optional part PCC-1A (capable of connecting the JST XHP -3 connector)	Five wires with connectors as one set
Wire (control)	Voltage: 12V DC	0.5 mm ²	
Wire (power)	Voltage: 230V	2.0 mm ²	

**NOTE**

- *The connection of the input signal is only an example.*
- *Keep the CN1 and CN2 wires as short as possible.*
- *Do not run the wires along 230 V/400 V CA power cables separately install them at a distance of more than 30cm. (The cables may intersect.)*
- *If you install the wires along a power supply wire, insert the wires in a metal conduit tube and ground one end of the tube.*
- *The maximum wiring length is 70 m. If you use this function, it is recommended that you use safety devices such as an electrical leakage breaker or a smoke detector.*

6.1.2 Available optional signals

The outdoor units have the following signals that are described in the following table.

These signals are set up through the PCB of the outdoor unit.

◆ RAS-(2-2.5)HVNP / RAS-3HVNC

Input signals

Ind.	Input signal	Application	Port
0	No setting application	No setting	—
1	Fixing the heating mode	This signal allows to pre-fix the operation mode, in this case the heating mode, independently of what the indoor unit requests. If the indoor units request the opposite mode than the outdoor unit, the compressor will not start. This is very useful to set up a unique operation mode.	CN1 and CN2
2	Fixing the cooling mode	This signal allows to pre-fix the operation mode, in this case the cooling mode, independently of what the indoor unit requests. If the indoor units request the opposite mode than the outdoor unit, the compressor will not start. This is very useful for computer rooms where the cooling mode is fixed throughout the year.	CN1 and CN2
3	Demand thermo OFF	This signal allows to stop the compressor if it reaches a certain power as well as to put the indoor unit in Thermo-OFF. This is very useful for installations with high power consumption.	CN1 and CN2
4	Forced stoppage	This signal allows to control the stoppage of the compressor and the fans of the indoor as well as outdoor units. This is very useful when used with the alarm signals of the fire prevention systems.	CN1 and CN2
5	Current control demand 60%	This signal allows to regulate current consumption and establish an average consumption of 60% of the rate point. This is very useful for installations that run 24 hours a day.	CN1 and CN2
6	Current control demand 80%	This signal allows to regulate current consumption and establish an average consumption of 80% of the rate point. This is very useful for installations that run 24 hours a day.	CN1 and CN2
7	Current control demand 100%	This signal allows to regulate current consumption and establish an average consumption of 100% of the rate point. This is very useful for installations that run 24 hours a day.	CN1 and CN2

Output signals

Ind.	Output signal	Application	Port
0	No setting application	No setting	—
01	Operation signal	This signal allows to pick up the machine's operation signal. This is very useful to start up additional systems such as humidifiers, fans and other additional air-conditioning systems.	CN7
02	Alarm signal	This signal picks up the machine's alarm. This is very useful to warn that an alarm has been tripped.	CN7
03	Compressor ON signal	This signal allows to pick up the compressor's operation signal. It is very useful for checking signals during remote-control operation and for the interlock of the outdoor unit.	CN7
04	Defrost operation signal	This signal allows to pick up the defrosting of the unit. This is very useful to know how the indoor unit is operating if there is an abnormal situation.	CN7



NOTE

Do not set same function to multiple input port. If set, the higher input terminal number will be cancelled.

◆ RAS-3HVNPE / RAS-(4-12)H(V)N(P/C)(E)

Input signals

Ind.	Input signal	Application	Port
0	No setting application	No setting	—
1	Fixing the heating mode	This signal allows to pre-fix the operation mode, in this case the heating mode, independently of what the indoor unit requests. If the indoor units request the opposite mode than the outdoor unit, the compressor will not start. This is very useful to set up a unique operation mode.	CN1 and CN2
2	Fixing the cooling mode	This signal allows to pre-fix the operation mode, in this case the cooling mode, independently of what the indoor unit requests. If the indoor units request the opposite mode than the outdoor unit, the compressor will not start. This is very useful for computer rooms where the cooling mode is fixed throughout the year.	CN1 and CN2
3	Demand thermo OFF	This signal allows to stop the compressor if it reaches a certain power as well as to put the indoor unit in Thermo-OFF. This is very useful for installations with high power consumption. This signal is only activated if function F1 has value 1.	CN1 and CN2
4	No setting application	No setting	—
5	Forced stoppage	This signal allows to control the stoppage of the compressor and the fans of the indoor as well as outdoor units. This is very useful when used with the alarm signals of the fire prevention systems. This signal is only activated if function F1 has value 1.	CN1 and CN2
6	Current control demand 60%	This signal allows to regulate current consumption and establish an average consumption of 60% of the rate point. This is very useful for installations that run 24 hours a day.	CN1 and CN2
7	Current control demand 70%	This signal allows to regulate current consumption and establish an average consumption of 70% of the rate point. This is very useful for installations that run 24 hours a day.	CN1 and CN2
8	Current control demand 80%	This signal allows to regulate current consumption and establish an average consumption of 80% of the rate point. This is very useful for installations that run 24 hours a day.	CN1 and CN2
9	Current control demand 100%	This signal allows to regulate current consumption and establish an average consumption of 100% of the rate point. This is very useful for installations that run 24 hours a day.	CN1 and CN2
10	No setting application	No setting	—

Output signals

Ind.	Output signal	Application	Port
0	No setting application	No setting	—
01	Operation signal	This signal allows to pick up the machine's operation signal. This is very useful to start up additional systems such as humidifiers, fans and other additional air-conditioning systems.	CN7
02	Alarm signal	This signal picks up the machine's alarm. This is very useful to warn that an alarm has been tripped.	CN7
03	Compressor ON signal	This signal allows to pick up the compressor's operation signal. It is very useful for checking signals during remote-control operation and for the interlock of the outdoor unit.	CN7
04	Defrost operation signal	This signal allows to pick up the defrosting of the unit. This is very useful to know how the indoor unit is operating if there is an abnormal situation.	CN7



NOTE

Do not set same function to multiple input port. If set, the higher input terminal number will be cancelled.

6.1.3 Setting of the optional signals

The optional signals of the outdoor unit are set up from the PCB of the outdoor unit and can be selected by pushing switches PSW1, PSW2 and PSW3.



NOTE

Before setting the optional signals, must be complied the following conditions:

- **Outdoor unit must be stopped**
- **Check mode must not be selected**
- **External optional signal must not be connected**

If the initial setting has to be modified, the following instructions must be followed:

- 1 Set pin 6 of DSW2 to ON. Set pin 4 of DSW1 to ON. Because of these settings, the input/output signals selection mode becomes available and the following indication appears on the 7-segment display.

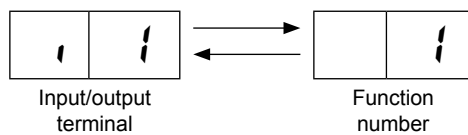

This example indicates that function number 1 “Fixing the heating mode” is set at input 1.

- 2 By pressing the push switches PSW2 and PSW3, it can be changed the input/output terminal name. (See the flowchart show in the side).
- 3 By pressing the push switch PSW1, it can be changed the function number. (See the flowchart show in the side)
- 4 After selecting the function number, return pin 6 of DSW2 to OFF position and pin 4 of DSW1 to OFF.

The selected contents are memorized in the outdoor unit printed circuit board and the function selection mode is stopped. The memorized data is maintained even power source lines are disconnected. The connecting details of each function are described, and the required parts are also indicated in the section [Description of the optional signals](#) on this chapter.

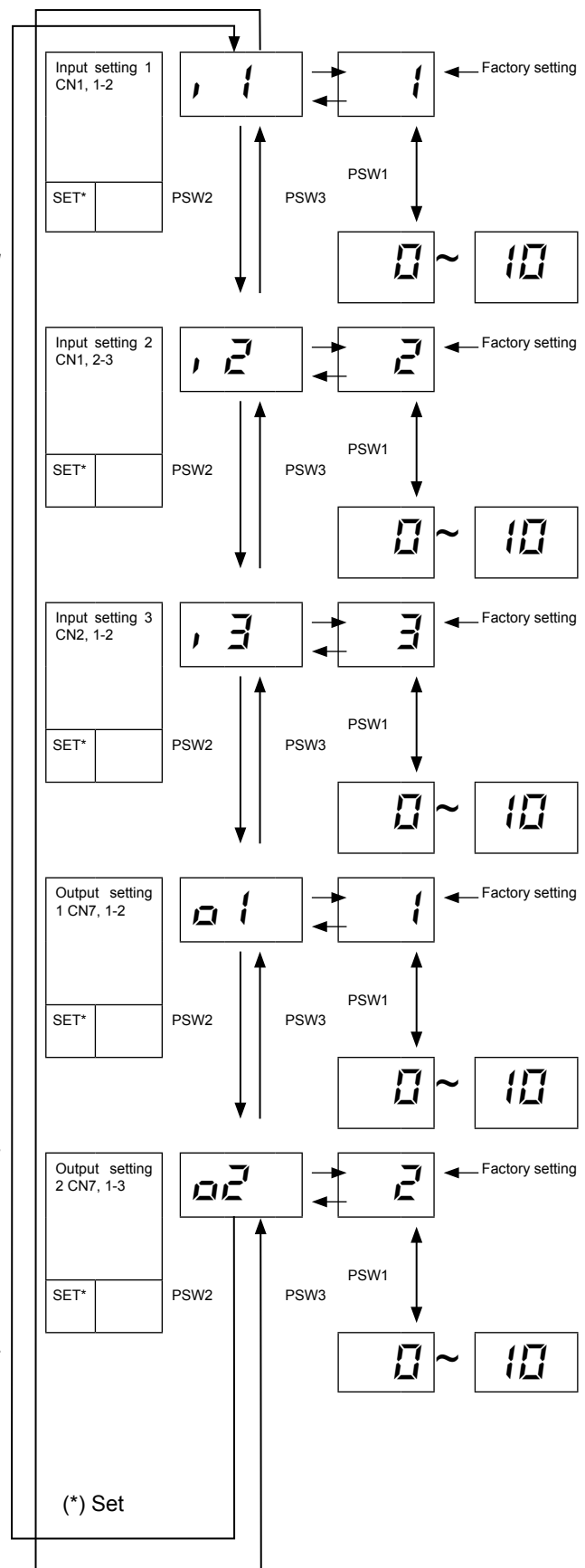

6.1.4 Description of optional signals

◆ Input signals

RAS-(2-2.5)HVNP / RAS-3HVNC

1 Fixing operation mode (heating / cooling)(1/2)

This input function is fixed in terminals CN1 or CN2 of the PCB of the outdoor unit, to use it as a cooling and heating mode. CN1 must be set up as follows.

Short circuit between the terminals 1 and 2 of CN1: set heating mode.

Short circuit between the terminals 2 and 3 of CN1: set cooling mode.

After having pre-fixed the established mode, the remote control can only be used to adjust the temperatures. Stoppage code "d1" "20" will be displayed if an attempt is made to change the operation mode of any of the indoor units with the remote control.

Example of wiring diagram of fixing the operation mode.

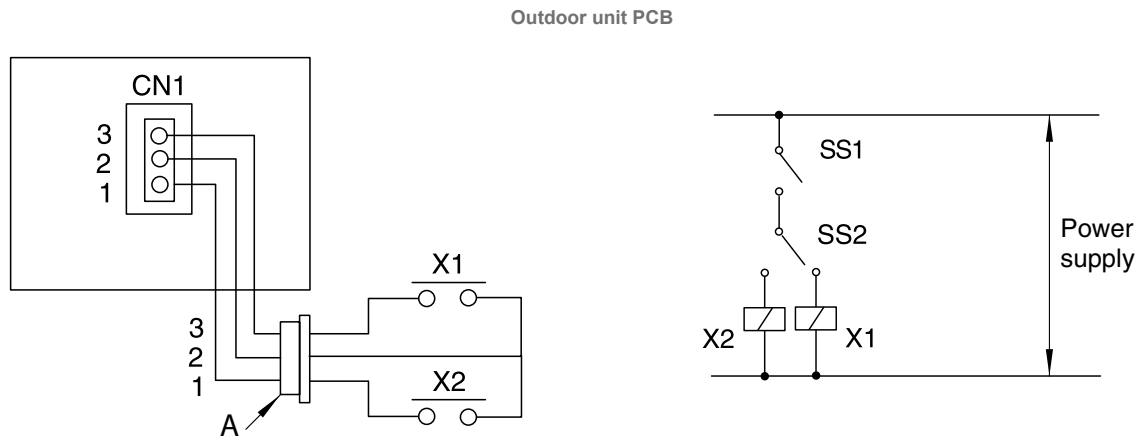

- A: 3P connector cable.
- X1: Cooling.
- X2: Heating.
- SS1: Fixing operation mode switch.
- SS2: Change over switch

2 Demand thermo OFF (3)

This is an input function to control the maximum power that the compressor can consume. When this option is turned on, the outdoor units are stopped completely, and the indoor units go into thermo-OFF. Alarm "10" is displayed on the remote control. If the switch of this function is disconnected it becomes available again.

Connect the cabling and use the materials as shown in [Available ports](#).

3 Forced stoppage (4)

This is an input function that turns on when the switch receives a signal that causes the compressor and the fan motor of the indoor unit to stop; alarm "10" displays on a remote-controlled when this option turns on. If the switch of this function is disconnected it becomes available again.

Connect the cabling and use the materials as shown in [Available ports](#).

4 Current control demand (5/6/7)

This is an input function that turns on when it detects that the frequency of the compressor reaches 60%, 80% or 100%.

The frequency of the compressor is determined when the maximum current reaches the established limit.

Connect the cabling and use the materials as shown in [Available ports](#).

If the running current of the outdoor unit exceeds the maximum limit, the unit changes to the thermo-OFF condition. Stoppage cause code "10" will appear. When the input terminal is opened during the demand current control, the control of the input terminal is reset.

RAS-3HVNPE / RAS-(4-12)H(V)N(P/C)(E)

1 Fixing operation mode (heating / cooling)(1/2)

This input function is fixed in terminals CN1 or CN2 of the PCB of the outdoor unit, to use it as a cooling and heating mode. CN1 must be set up as follows.

Short circuit between the terminals 1 and 2 of CN1: set heating mode.

Short circuit between the terminals 2 and 3 of CN1: set cooling mode.

After having pre-fixed the established mode, the remote control can only be used to adjust the temperatures. Stoppage code "d1" "20" will be displayed if an attempt is made to change the operation mode of any of the indoor units with the remote control.

Example of wiring diagram of fixing the operation mode.

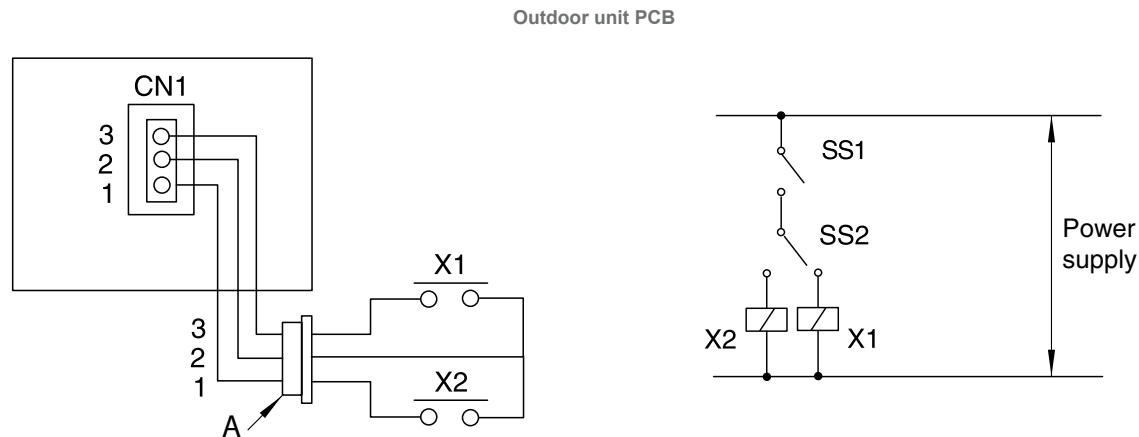

- A: 3P connector cable.
- X1: Cooling.
- X2: Heating.
- SS1: Fixing operation mode switch.
- SS2: Change over switch

2 Demand thermo OFF (3)

This is an input function to control the maximum power that the compressor can consume. When this option is turned on, the outdoor units are stopped completely, and the indoor units go into thermo-OFF. Alarm "10" is displayed on the remote control. If the switch of this function is disconnected it becomes available again.

Connect the cabling and use the materials as shown in [Available ports](#).

3 Forced stoppage (5)

This is an input function that turns on when the switch receives a signal that causes the compressor and the fan motor of the indoor unit to stop; alarm "10" displays on a remote-controlled when this option turns on. If the switch of this function is disconnected it becomes available again.

Connect the cabling and use the materials as shown in [Available ports](#).

4 Current control demand (6/7/8/9)

This is an input function that turns on when it detects that the frequency of the compressor reaches 60%, 70%, 80% or 100%.

The frequency of the compressor is determined when the maximum current reaches the established limit.

Connect the cabling and use the materials as shown in [Available ports](#).

If the running current of the outdoor unit exceeds the maximum limit, the unit changes to the thermo-OFF condition. Stoppage cause code "10" will appear. When the input terminal is opened during the demand current control, the control of the input terminal is reset.

◆ Output signals

Operation signal (01)

This optional signal is used to pick up the operation signal. It can be used to turn on or off complementary units of the air-conditioning system, such as fans, humidifiers, etc.

Connect the cabling and use the materials as shown in [Available ports](#).

Note that the contact of auxiliary relay X3 is closed when an operation signal is issued.

Alarm signal (02)

This optional signal is used to pick up the activation of safety devices.

Connect the cabling and use the materials as shown in [Available ports](#).

Note that the contact of auxiliary relay X3 is closed when an operation signal is issued.

Compressor on signal (03)

This optional signal is used to pick up the signal when the compressor is ON. It can be used to check how the compressor is running at all times. It is very useful for locking the compressor when the fans are locked.

Connect the cabling and use the materials as shown in [Available ports](#).

Note that the contact of auxiliary relay X3 is closed when an operation signal is issued.

Defrost operation signal (04)

This optional signal is used to pick up when defrosting turns on. It is very useful to check if the indoor unit is in thermo-OFF.

Connect the cabling and use the materials as shown in [Available ports](#).

Note that the contact of auxiliary relay X3 is closed when an operation signal is issued.

6.2 Optional functions (By 7-segment display)

The outdoor unit has several optional functions which can be selected through the 7-segment display of the outdoor unit PCB.

6.2.1 Setting of the optional functions

The optional functions of the outdoor unit are set up from the PCB of the outdoor unit and can be selected by pushing switches PSW1, PSW2 and PSW3.



NOTE

Before setting the optional functions, must be complied the following conditions:

- **Outdoor unit must be stopped**
- **Check mode must not be selected**
- **External optional signal must not be connected**

If the initial setting has to be modified, the following instructions must be followed:

- 1 Set pin 5 of DSW2 to ON. Set pin 4 of DSW1 to ON. Because of these settings, the optional function selection mode becomes available and the following indication appears on the 7-segment display.

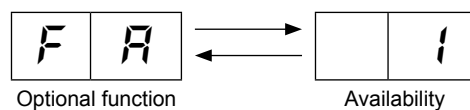

This example indicates that optional function “Control of the indoor unit fan during Thermo-OFF in heating mode” is available.

- 2 By pressing the push switches PSW2 and PSW3, it can be changed the optional function. (See the flowchart show in the next page).
- 3 By pressing the push switch PSW1, it can be selected the availability of this optional function. (See the flowchart show in the next page).
- 4 After selecting the function number, return pin 5 of DSW2 and pin 4 of DSW1 to OFF position.

The selected contents are memorized in the outdoor unit printed circuit board and the function selection mode is stopped. The memorized data is maintained even power source lines are disconnected. The details of each function are described in the section [Description of the optional functions](#) on this chapter.

IVX Premium

Control of the indoor unit fan during Thermo-OFF in heating mode	<div style="display: flex; justify-content: space-around;"> <div style="text-align: center;"> <p>① ↓</p> <p>SEG2</p> <p>FA</p> <p>PSW2 ↑</p> <p>↓ PSW3</p> </div> <div style="text-align: center;"> <p>↑ ③</p> <p>SEG1</p> <p>0</p> <p>PSW1 ↓</p> <p>↑ PSW2</p> </div> </div>	Not Available	Indoor exp. valve opening change for stoppage indoor unit in heating mode 1 or 2 (for 3 to 12HP)	<div style="display: flex; justify-content: space-around;"> <div style="text-align: center;"> <p>② ↓</p> <p>SEG2</p> <p>51</p> <p>PSW2 ↑</p> <p>↓ PSW3</p> </div> <div style="text-align: center;"> <p>↑ ④</p> <p>SEG1</p> <p>0</p> <p>PSW1 ↓</p> <p>↑ PSW2</p> </div> </div>	Not Available
Night mode (Low noise)	<div style="display: flex; justify-content: space-around;"> <div style="text-align: center;"> <p>PSW2 ↑</p> <p>ni</p> <p>↓ PSW3</p> </div> <div style="text-align: center;"> <p>PSW1 ↓</p> <p>0</p> <p>↑ PSW2</p> </div> </div>	Not Available	Indoor exp. valve opening change for Thermo-OFF indoor unit in heating mode 1/2 (for 3 to 12HP)	<div style="display: flex; justify-content: space-around;"> <div style="text-align: center;"> <p>PSW2 ↑</p> <p>50</p> <p>↓ PSW3</p> </div> <div style="text-align: center;"> <p>PSW1 ↓</p> <p>0</p> <p>↑ PSW2</p> </div> </div>	Not Available
Cancellation of outdoor ambient temperature limit of heating	<div style="display: flex; justify-content: space-around;"> <div style="text-align: center;"> <p>PSW2 ↑</p> <p>05</p> <p>↓ PSW3</p> </div> <div style="text-align: center;"> <p>PSW1 ↓</p> <p>0</p> <p>↑ PSW2</p> </div> </div>	Not Available	Indoor exp. valve initial opening of indoor unit in heating mode 1 or 2 (for 3 to 12HP)	<div style="display: flex; justify-content: space-around;"> <div style="text-align: center;"> <p>PSW2 ↑</p> <p>e1</p> <p>↓ PSW3</p> </div> <div style="text-align: center;"> <p>PSW1 ↓</p> <p>0</p> <p>↑ PSW2</p> </div> </div>	Not Available
Change of defrost condition	<div style="display: flex; justify-content: space-around;"> <div style="text-align: center;"> <p>PSW2 ↑</p> <p>do</p> <p>↓ PSW3</p> </div> <div style="text-align: center;"> <p>PSW1 ↓</p> <p>0</p> <p>↑ PSW2</p> </div> </div>	Not Available	Low noise setting	<div style="display: flex; justify-content: space-around;"> <div style="text-align: center;"> <p>PSW2 ↑</p> <p>db</p> <p>↓ PSW3</p> </div> <div style="text-align: center;"> <p>PSW1 ↓</p> <p>0</p> <p>↑ PSW2</p> </div> </div>	Not Available
Slo defrost setting	<div style="display: flex; justify-content: space-around;"> <div style="text-align: center;"> <p>PSW2 ↑</p> <p>bu</p> <p>↓ PSW3</p> </div> <div style="text-align: center;"> <p>PSW1 ↓</p> <p>0</p> <p>↑ PSW2</p> </div> </div>	Not Available	Fixing on demand function	<div style="display: flex; justify-content: space-around;"> <div style="text-align: center;"> <p>PSW2 ↑</p> <p>de</p> <p>↓ PSW3</p> </div> <div style="text-align: center;"> <p>PSW1 ↓</p> <p>0</p> <p>↑ PSW2</p> </div> </div>	Not Available
Cancellation of outdoor hot start limit (12HP)	<div style="display: flex; justify-content: space-around;"> <div style="text-align: center;"> <p>PSW2 ↑</p> <p>hf</p> <p>↓ PSW3</p> </div> <div style="text-align: center;"> <p>PSW1 ↓</p> <p>0</p> <p>↑ PSW2</p> </div> </div>	Not Available	Wave function setting	<div style="display: flex; justify-content: space-around;"> <div style="text-align: center;"> <p>PSW2 ↑</p> <p>ue</p> <p>↓ PSW3</p> </div> <div style="text-align: center;"> <p>PSW1 ↓</p> <p>0</p> <p>↑ PSW2</p> </div> </div>	Not Available
Capacity adjustment for long piping (for 3 to 12HP)	<div style="display: flex; justify-content: space-around;"> <div style="text-align: center;"> <p>PSW2 ↑</p> <p>nu</p> <p>↓ PSW3</p> </div> <div style="text-align: center;"> <p>PSW1 ↓</p> <p>0</p> <p>↑ PSW2</p> </div> </div>	Not Available	Cold draft protection 1 or 2 (for 3 to 12HP)	<div style="display: flex; justify-content: space-around;"> <div style="text-align: center;"> <p>PSW2 ↑</p> <p>Fb</p> <p>↓ PSW3</p> </div> <div style="text-align: center;"> <p>PSW1 ↓</p> <p>0</p> <p>↑ PSW2</p> </div> </div>	Not Available
Compressor frequency control target value for cooling	<div style="display: flex; justify-content: space-around;"> <div style="text-align: center;"> <p>PSW2 ↑</p> <p>Hc</p> <p>↓ PSW3</p> </div> <div style="text-align: center;"> <p>PSW1 ↓</p> <p>0</p> <p>↑ PSW2</p> </div> </div>	Not Available	Cancellation of hot gas bypass control (for 3 to 12HP)	<div style="display: flex; justify-content: space-around;"> <div style="text-align: center;"> <p>PSW2 ↑</p> <p>E1</p> <p>↓ PSW3</p> </div> <div style="text-align: center;"> <p>PSW1 ↓</p> <p>0</p> <p>↑ PSW2</p> </div> </div>	Not Available
Compressor frequency control target value for heating	<div style="display: flex; justify-content: space-around;"> <div style="text-align: center;"> <p>PSW2 ↑</p> <p>Hh</p> <p>↓ PSW3</p> </div> <div style="text-align: center;"> <p>PSW1 ↓</p> <p>0</p> <p>↑ PSW2</p> </div> </div>	Not Available	Forcibly stoppage after defrost operation (for 3 to 12HP)	<div style="display: flex; justify-content: space-around;"> <div style="text-align: center;"> <p>PSW2 ↑</p> <p>d5</p> <p>↓ PSW3</p> </div> <div style="text-align: center;"> <p>PSW1 ↓</p> <p>0</p> <p>↑ PSW2</p> </div> </div>	Not Available
Not prepared	<div style="display: flex; justify-content: space-around;"> <div style="text-align: center;"> <p>PSW2 ↑</p> <p>sc</p> <p>↓ PSW3</p> </div> <div style="text-align: center;"> <p>PSW1 ↓</p> <p>0</p> <p>↑ PSW2</p> </div> </div>	Not Available	Defrost control in demand mode (for 3 to 12HP)	<div style="display: flex; justify-content: space-around;"> <div style="text-align: center;"> <p>PSW2 ↑</p> <p>F1</p> <p>↓ PSW3</p> </div> <div style="text-align: center;"> <p>PSW1 ↓</p> <p>0</p> <p>↑ PSW2</p> </div> </div>	Not Available
	<div style="display: flex; justify-content: space-around;"> <div style="text-align: center;"> <p>② ↓</p> <p>PSW2 ↑</p> <p>1</p> <p>↓ PSW3</p> </div> <div style="text-align: center;"> <p>④ ↑</p> <p>PSW1 ↓</p> <p>1</p> <p>↑ PSW2</p> </div> </div>	Available	Not prepared	<div style="display: flex; justify-content: space-around;"> <div style="text-align: center;"> <p>① ↓</p> <p>F2~F6</p> <p>↓ PSW3</p> </div> <div style="text-align: center;"> <p>③ ↑</p> <p>0</p> <p>↑ PSW2</p> </div> </div>	Not Available

IVX Standard

	① ↓	SEG2	SEG1	③ ↑			SEG2	SEG1	② ↓	④ ↑	
Control of the indoor unit fan during Thermo-OFF in heating mode		FA	0		Not Available	Not prepared	51	0			Not Available
SET*		PSW2 ↑		PSW1 ↓		SET*	PSW2 ↑		PSW3 ↓	PSW1 ↓	
		PSW3 ↓		PSW1 ↓	Available		PSW3 ↓			PSW1 ↓	Available
Night mode (Low noise)		n1	0		Not Available	Indoor exp. valve opening change for Thermo-OFF indoor unit in heating mode 1 (mode 2 not prepared)	50	0			Not Available
SET*		PSW2 ↑		PSW1 ↓		SET*	PSW2 ↑		PSW3 ↓	PSW1 ↓	
		PSW3 ↓		PSW1 ↓	Available		PSW3 ↓			PSW1 ↓	Available
Cancellation of outdoor ambient temperature limit of heating		05	0		Not Available	Not prepared	e1	0			Not Available
SET*		PSW2 ↑		PSW1 ↓		SET*	PSW2 ↑		PSW3 ↓	PSW1 ↓	
		PSW3 ↓		PSW1 ↓	Available		PSW3 ↓			PSW1 ↓	Available
Change of defrost condition		da	0		Not Available	Low noise setting	db	0			Not Available
SET*		PSW2 ↑		PSW1 ↓		SET*	PSW2 ↑		PSW3 ↓	PSW1 ↓	
		PSW3 ↓		PSW1 ↓	Available		PSW3 ↓			PSW1 ↓	Available
Slo defrost setting		bu	0		Not Available	Fixing on demand function	de	0			Not Available
SET*		PSW2 ↑		PSW1 ↓		SET*	PSW2 ↑		PSW3 ↓	PSW1 ↓	
		PSW3 ↓		PSW1 ↓	Available		PSW3 ↓			PSW1 ↓	Available
Cancellation of outdoor hot start limit (12HP)		hf	0		Not Available	Wave function setting	ue	0			Not Available
SET*		PSW2 ↑		PSW1 ↓		SET*	PSW2 ↑		PSW3 ↓	PSW1 ↓	
		PSW3 ↓		PSW1 ↓	Available		PSW3 ↓			PSW1 ↓	Available
Capacity adjustment for long piping (for 4 to 12HP)		nu	0		Not Available	Cold draft protection 1 or 2 (for 4 to 12HP)	fb	0			Not Available
SET*		PSW2 ↑		PSW1 ↓		SET*	PSW2 ↑		PSW3 ↓	PSW1 ↓	
		PSW3 ↓		PSW1 ↓	Available		PSW3 ↓			PSW1 ↓	Available
Compressor frequency control target value for cooling		hc	0		Not Available	Not prepared	e1	0			Not Available
SET*		PSW2 ↑		PSW1 ↓		SET*	PSW2 ↑		PSW3 ↓	PSW1 ↓	
		PSW3 ↓		PSW1 ↓	Available		PSW3 ↓			PSW1 ↓	Available
Compressor frequency control target value for heating		hh	0		Not Available	Forcibly stoppage after defrost operation (for 4 to 12HP)	ds	0			Not Available
SET*		PSW2 ↑		PSW1 ↓		SET*	PSW2 ↑		PSW3 ↓	PSW1 ↓	
		PSW3 ↓		PSW1 ↓	Available		PSW3 ↓			PSW1 ↓	Available
Not prepared		sc	0		Not Available	Defrost control in demand mode (for 4 to 12HP)	f1	0			Not Available
SET*		PSW2 ↑		PSW1 ↓		SET*	PSW2 ↑		PSW3 ↓	PSW1 ↓	
		PSW3 ↓		PSW1 ↓	Available		PSW3 ↓			PSW1 ↓	Available
						Not prepared	f2~f6	0			Not Available

6.2.2 Description of the optional functions

Control of the indoor unit fan during Thermo-OFF in heating mode (FR)

Press PSW1 and select the setting condition "1" at the circulator function at heating thermo-OFF "FR".

In case that the fan speed is changed to "LOW" at heating Thermo-OFF, there is a case that the room air temperature is too high at heating Thermo-OFF.

In this case, the circulator function at heating thermo-OFF is recommended, and its function explains below.

The indoor fan operates for 2 minutes and stops for 6 minutes as a cycle when the activation conditions are satisfied.

- Operation

When the indoor unit is at thermo-OFF during the heating operation, the indoor fan operates and stops for 6 minutes in 2 minute cycles

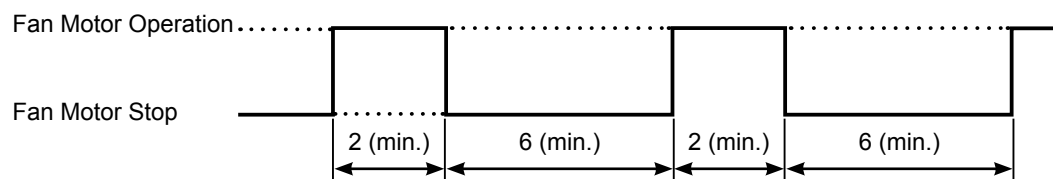

NOTE

When the indoor fan is stopped by another control, it is not available to operate indoor fans.

Night mode (Low noise) (n i)

Press PSW1 and select the setting condition "1" at the night shift (low noise) "n i". Then, this function can be set (only in cooling operation).

The outdoor fan operation is controlled by fan controller as shown below.

The night shift operation shall be applied in case that the cooling capacity has the margin to be allowed for the capacity decrease and the low sound operation is required especially in the nighttime.

- Outdoor Fan

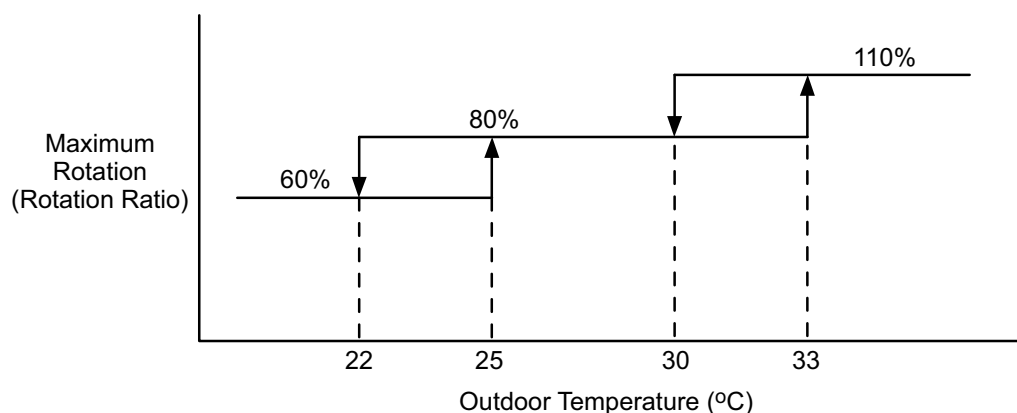

NOTE

When the outdoor temperature is lower than 30°C in the cooling operation, the compressor frequency and the outdoor fan speed will be operated low. In this case, the cooling capacity decreases to approximately 60% at the same time.

Cancellation of Outdoor Ambient Temperature Limit (U5)

Press "PSW1" and select the setting condition "0" to "3" at the cancellation of outdoor ambient temperature limit of "U5". Then, this function can be set.

The heating operation is continued under a high outdoor temperature or the cooling operation is continued under a low temperature.

Setting condition*	Operation mode for cancellation
0	Not available (default setting)
1	Heating
2	Cooling
3	Heating / Cooling

Cancelled Conditions for Outdoor Unit Ambient Temperature Limit

- Heating Operation

If one of following conditions is continued for 1 second, the unit will be under Thermo-OFF.

- $T_a \geq 23^\circ\text{C}$ and $P_d \geq 3.7 \text{ MPa}$
- $T_a \geq 21^\circ\text{C}$, $T_i \geq 26^\circ\text{C}$ and $P_d \geq 3.7 \text{ MPa}$
- $T_a \geq 15^\circ\text{C}$, $T_i \geq 29^\circ\text{C}$ and $P_a \geq 3.7 \text{ MPa}$

- Cooling Operation

If the following condition is continued for 1 second, the unit will be under Thermo-OFF.

- $T_a < -7^\circ\text{C}$

T_a : Outdoor Ambient Temperature

T_i : Indoor Air Inlet Temperature

P_d : Discharge Pressure



NOTE

If this function is set and the outdoor unit operates in the stoppage area for a long time, the outdoor unit may be damaged since protection control is cancelled.

Change of defrost condition (U6)

Press "PSW1" and select the setting condition "1" at the change of defrost condition "U6".

Example for RAS-(3-12)H(V)N(P/C)(E):

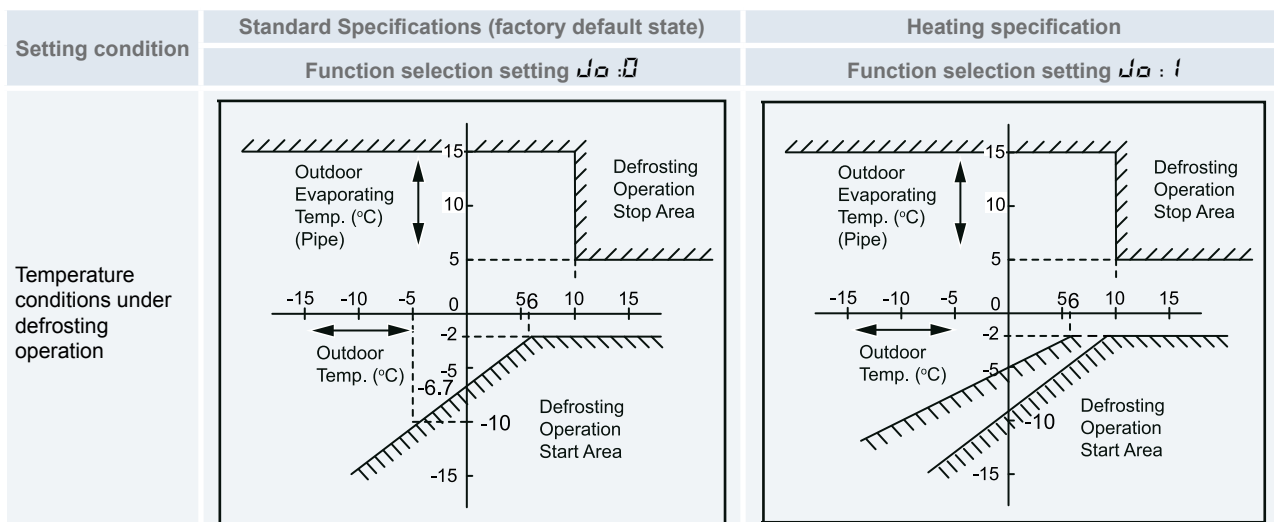

Slo defrost setting (b_d)

Press "PSW1" and select the setting condition "1" at the slow defrost setting "b_d".

Indoor fan operation is stopped during the defrost operation.

Setting condition*	Indoor fan operation
0	Indoor fan stop during defrost operation
1	Indoor fan SLo during defrost operation

Cancellation of outdoor hot start limit (H_F)

Press "PSW1" and select the setting condition "1" at the cancellation of hot start setting "H_F", so the hot start protection control can be canceled.

Long piping setting (r_L)

Press "PSW1" and select the setting condition "1" at the long piping setting "r_L".

If cooling capacity or heating capacity is not enough under the long-distance piping condition, this function can be set the target compressor frequency higher than normal target value.

Wave function setting (L_E)

Press "PSW1" and select the setting condition "1", so that the wave function setting "L_E".

While this function is activated, the maximum limit of running current is changed from 60% to 100% as shown in the figure.

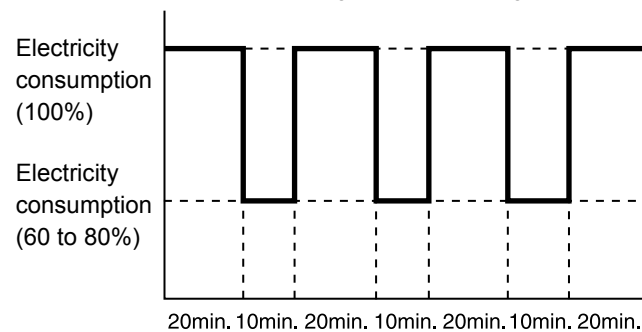

6

**NOTE**

- *Wave function can be activated when demand function is selected at one of the input terminal indications 1, 2 and 3.*
- *The minimum limit of running current control is according to the set value of the demand function.*
- *If demand function is not set at the input terminal indication, this function can not be activated.*

Fixing on demand function (dE)

Press "PSW1" and select the setting condition "1", so that the fixing of demand function " dE " can be set.

However, it is not necessary to short-circuit the demand input terminals on the outdoor unit PCB. (Refer to section [Description of optional signals](#) in the input [Current control demand](#))

The tables below is the limit of the running current for this function.

RAS-(2-2.5)HVNP / RAS-3HVNC

Control function number (*)	Demand running current control
1 to 4	100%
5	60%
6	80%
7	100%

(*) This function can be activated when demand function is selected at one of the input terminal indications $i1$, $i2$ and $i3$. In case that multiple demand functions are set at the input terminal indications $i1$, $i2$ and $i3$, the demand running current is selected as below.

$5 > 6 > 7$
(Control function number)

RAS-3HVNP / RAS-(4-12)H(V)N(P/C)(E)

Control function number (*)	Demand running current control
1 to 5, 10	100%
6	60%
7	70%
8	80%
9	100%

(*) This function can be activated when demand function is selected at one of the input terminal indications $i1$, $i2$ and $i3$. In case that multiple demand functions are set at the input terminal indications $i1$, $i2$ and $i3$, the demand running current is selected as below.

$6 > 7 > 8 > 9$
(Control function number)

- Demand Control.

Adopting self-demand function which drastically decreases power consumption has largely improved energy-saving.

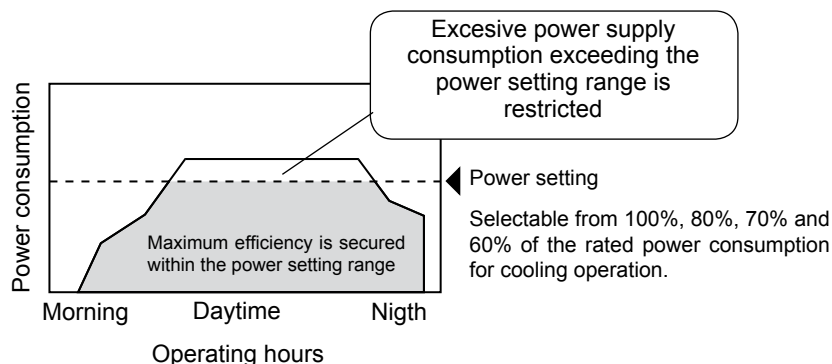

Cold draft protection 1 (Fb)

Press PSW1 and select the setting condition "1" at the cold draft protection 1 " Fb ", so the cold draft protection can be set. When the minimum indoor unit discharge air temperature falls down to 12°C and below at cooling operation, outdoor fan stops and compressor frequency forcibly decreases to prevent a drop in discharge air temperature.

Setting condition	Temperature (°C)	Condition
0	-	Not available (default setting)
1	< 12	The cold draft is prevented by the compressor frequency control and turning ON SVC (solenoid valve for high pressure bypass circuit).
2	< 12	The cold draft is prevented by the compressor frequency control.

6.3 Optional functions (By remote control switch)

Additionally to the possible optional functions by the 7-segment display of the outdoor unit's PCB, there are available a large quantity of optional functions for each remote control switch connected to the system.

An example of the available optional functions by one of the HITACHI remote control switches (PC-ART) is shown below:



NOTE

- **Please, refer to the Controller's Technical Catalogue for the specific information about the optional functions of PC-ART and for the rest of HITACHI's remote controls.**
- **The optional functions shown in the following table for PC-ART are the last updated at time of publication. In order to know the current optional functions, refer to the Controller's Technical Catalogue.**

Items	Optional function	Individual setting	Setting condition	Contents
b1	Removal of heating temperature compensation	○	00	Standard (Set temperature +4°C)
			01	Removal (Set temperature)
			02	Set temperature +2°C (*1)
b2	Circulator function at heating Thermo-OFF	○	00	Not available
			01	Available
b3	3 minutes OFF guard compressor	○	00	Not available
			01	Available
b4	Period for filter sign	○	00	Standard
			01	100 hours
			02	1,200 hours
			03	2,500 hours
			04	No indication
b5	Fixing of operation mode	×	00	Not available
			01	Available
b6	Fixing of setting temperature	×	00	Not available
			01	Available
b7	Fixing cooling operation	×	00	Not available
			01	Available
b8	Automatic COOL/HEAT operation	×	00	Not available
			01	Available
b9	Fixing fan speed	×	00	Not available
			01	Available
bA	Not prepared	×	"- -" Fixed	Not used
bb	Cooling temperature compensation	○	00	Standard (No compensation)
			01	Set temperature -1°C
			02	Set temperature -2°C
bC	Not prepared	-	00	Not used
			01	(Use as 00 conditions)
bd	Not prepared	-	00	Not used
			01	(Use as 00 conditions)
bE	Not prepared	-	00	Not used
			01	(Use as 00 conditions)
C1	Not prepared	-	00	Not used
			01	(Use as 00 conditions)

Items	Optional function	Individual setting	Setting condition	Contents
C2	Not prepared	-	"--" Fixed	Not used
C3	Not prepared	-	00	Not used
			01	(Use as 00 conditions)
C4	Not prepared	-	00	Not used
			01	(Use as 00 conditions)
C5	Static pressure selection (RPI)	○	00	Average static pressure (factory set)
			01	High static pressure
			02	Low static pressure
	Increased fan speed (RCI, RCIM, RCD)		00	Normal
			01	Speed increase 1
			02	Speed increase 2
C6	Increasing fan speed	○	00	Not available
			01	Available
C7	Canceling 3 minutes compressor guard	○	00	Standard
			01	Cancellation
C8	Thermistor of remote control switch	○	00	Control by indoor suction thermistor
			01	Control by thermistor of remote control switch
			02	Control by average value of indoor suction thermistor and thermistor of remote control switch
C9	Not prepared	-	"--" Fixed	Not used
CA	Not prepared	-	"--" Fixed	Not used
Cb	Selection of forced stoppage logic	×	00	Forced stoppage input: A contact
			01	Forced stoppage input: B contact
CC	Not prepared	×	00	Not used
			01	(Use as 00 conditions)
Cd	Not prepared	○	00	Not used
			01	(Use as 00 conditions)
CE	Not prepared	-	00	Not used
			01	(Use as 00 conditions)
CF	Change of louver swing angle	○	00	Standard (7 steps)
			01	Draft prevention (5 steps)
			02	High ceiling (5 steps) (*2)
d1	Power supply ON/OFF 1	○	00	Not available
			01	Available
d2	Not prepared	-	"--" Fixed	Not used
			00	Not available
d3	Power Supply ON/OFF 2	○	01	Available
			00	Not available
d4	Prevention for cooling discharge air temperature decrease	○	01	Available
			00	Not available
d5	Prevention for heating discharge air temperature decrease	○	01	Available
			00	Not available
d6	Room temperature control for energy saving	○	00	Not available
			01	Available
d7	Not prepared	○	00~07	Not used (Use as 00 conditions)

Items	Optional function	Individual setting	Setting condition	Contents
E1	KPI: Ventilation mode	○	00	Automatic ventilation
			01	Ventilation with total heat exchanger
			02	Ventilation with bypass (No total heat exchange)
	Econofresh: all fresh mode		00	Not available
			01/02	All fresh mode
E2	KPI: Increasing air supply volume	○	00	Not available
			01	Available
	Econofresh: Enthalpy sensor		00	Not available
			01	Available
E3	Not prepared	○	00	Not used
			01	(Use as 00 conditions)
E4	KPI: Pre-cooling / Pre-Heating period	○	00	Standard
			01	30 minutes
			02	60 minutes
	Econofresh: gas sensor		00	Standard
			01/02	CO ² sensor
E5	Not Prepared	○	00	Not used
			01	(Use as 00 conditions)
E6	Indoor fan operation time after cooling operation stoppage	○	00	Not available
			01	60 min.
			02	120 min.
E7	Not prepared	-	00	Not used
			01	(Use as 00 conditions)
E8	Fan operation control at heating Thermo-OFF	○	00	Not available
			01	Available
E9	Not prepared	-	00	Not used
			01	(Use as 00 conditions)
EA	Not prepared	○	00	Not used
			01	(Use as 00 conditions)
Eb	Fan operation control at cooling Thermo-OFF	○	00	Not available
			01	LOW
			02	SLOW
EC	Forced Thermo-ON stoppage at cooling	○	00	Not available
			01	Available
Ed	Not prepared	○	00	Not used
			01	(Use as 00 conditions)
EE	Automatic fan speed control	○	00	Not available
			01	Available
F0	Not prepared	○	00	Not used
			01	(Use as 00 conditions)

Items	Optional function	Individual setting	Setting condition	Contents
F1	Automatic timer OFF setting	×	00	Function not valid
			01	1 h
			02	2 h
			03	3 h
			04-24	(04-24) h
			0A	0.5 h
			0B	1.5 h
			0C	40 mins
			0D	45 mins
			0E	50 mins
0F	55 mins			
F2	Main and secondary remote control setting	×	00	Master
			01	Slave
F3	Automatic temperature setting release (*3)	×	00	Not available
			01	Available
F4	Automatic release time	×	00	30 minutes (Factory setting)
			01	15 minutes
			02	60 minutes
			03	90 minutes
F5	Automatic cooling temperature release (*4)	×	19	19 °C
			20	20 °C
			21-24	(21-24) °C
			25	25 °C (Factory setting)
			26-28	(26-28) °C
			29	29 °C
			30	30 °C
F6	Automatic heating temperature release (*5)	×	19	19 °C
			20	20 °C
			21-24	(21-24) °C
			25	25 °C (Factory setting)
			26-28	(26-28) °C
			29	29 °C
			30	30 °C
F7	Prevention of operation stoppage due to remote control operating error (*6)	×	00	Not available
			01	Available
F8	Lock function for operation mode selection	×	00	Not available
			01	Available (Factory-setting)
F9	Lock function for temperature setting	×	00	Not available
			01	Available (Factory-setting)
FA	Lock function for fan speed selection	×	00	Not available
			01	Available (Factory-setting)
Fb	Lock function for swing louver operation	×	00	Not available
			01	Available (Factory-setting)

Items	Optional function	Individual setting	Setting condition	Contents
FC	Cooling lower limit for setting temperature (*4)	x	00	Standard
			01	Lower limit +1°C
			02	Lower limit +2°C
		
			09	Lower limit +9°C
			10	Lower limit +10°C
Fd	Heating upper limit for setting temperature (*5)	x	00	Standard
			01	Upper limit -1°C
			02	Upper limit -2°C
		
			11	Upper limit -11°C
			12	Upper limit -12°C
FE	Not prepared	-	00	Not used
			01	(Use as 00 condition)
			02	
FF	Not prepared	-	00	Not available
			01	(Use as 00 condition)
H1	Not prepared	-	00	Not available
			01	(Use as 00 condition)
H2	Indication of hot start	x	00	Show
			01	Hide
H3	Not prepared	-	00	Not available
			01	(Use as 00 condition)
H4	Not prepared	-	00	Not available
			01	(Use as 00 condition)
H5	Not prepared	-	00	Not available
			01	(Use as 00 condition)
J1	Temperature indication (*7)	x	00	Not available
			01	Available
J2	Not prepared	-	00	Not available
			01	(Use as 00 condition)
J3	Run indicator color	x	00	Green
			01	Red
J4	Not prepared	-	00	Not available
			01	(Use as 00 condition)
J5	Not prepared	x	00	Not available
			01	(Use as 00 condition)
J6	Not prepared	x	00	Not available
			01	(Use as 00 condition)
J7	Not prepared	-	00	Not available
			01	(Use as 00 condition)
J8	Eco-operation (*8)	x	00	Not available
			01	Available
J9	Not prepared	-	00	Not available
			01	(Use as 00 condition)

Items	Optional function	Individual setting	Setting condition	Contents
JA	Not prepared	-	00	Not available
			01	(Use as 00 condition)
Jb	Not prepared	-	00	Not available
			01	(Use as 00 condition)
K1	Not prepared	x	00	Not available
			01	(Use as 00 condition)
K2	Not prepared	x	00	Not available
			01	(Use as 00 condition)
K3	Not prepared	x	00	Not available
			01	(Use as 00 condition)
K4	Not prepared	-	00	Not available
			01	(Use as 00 condition)
K5	Motion sensor detection level	-	00	Standard
			01	High
			02	Low

○: Allow individual setting.

×: Setting is used for all the outdoor units

-: Not used



NOTE

***1: The "02" setting may not be available according to the type of indoor unit.**

***2: 00: Standard (7-step operation), 01: Draft Prevention (lower 2 steps cutoff), 02: High ceiling (upper 2 steps cut off)**

***3: In case that the set temperature is changed and kept within the set time at "F4", the temperature is automatically changed to "F5" and "F6". (In case that the set temperature is out of range at "F5" and "F6", it is applied within upper and lower limit for the set temperature.)**

***4: Applicable to fan, cooling and dry operation modes.**

***5: Applicable to heating operation mode.**

***6: Operation is stopped by pressing the "⏻" (run/stop) switch for 3 seconds.**

***7: The sensor value at "C8" will be indicated. When the thermistor for remote control switch is used, the average value of the thermistor for remote control switch and the thermistor for indoor inlet will be indicated.**

***8: When the unit is restarted by the remote control switch, the temperature automatically changes to the setting temperature of "F5" or "F6".**

- After at least 3 minutes from the power ON, not change the optional setting.
- When changing "CF" setting (change of louver swing range), restore the power supply or allow the louver to make one complete swing fully in the auto swing mode to apply the optional setting.
- The optional settings are different according to the indoor and outdoor unit models. Check to ensure that the unit has the optional setting or not.
- Record the setting conditions for each optional setting in the "Setting" column of the table.
- The above optional functions with "X" mark at the individual setting can change the condition only when "All Rooms" is set.

7 . Test run

Index

7.1. Checking procedure before the test run.....	168
7.2. Test run procedure using the remote control switch (PC-ART).....	170
7.3. Test run procedure using the remote control switch (PC-ARF).....	172
7.4. Test run procedure using the wireless remote control switch (PC-LH3A/B).....	175
7.5. Test run procedure from the outdoor unit side.....	177
7.6. Check list.....	179
7.6.1. Check list on test run.....	179
7.6.2. Check list on compressor.....	180

7.1 Checking procedure before the test run

When you have finished the installation, perform the test run according to the following procedure. After performing the test run, hand over the system to the customer.

Perform the test run of the indoor units one by one in order.

Make sure that the electrical wiring and the refrigerant piping are correctly connected.

Start the indoor units one by one in order to make sure that the indoor units are correctly numbered.

You should perform the test run according to [Test run procedure using the remote control switch](#) on next pages.



DANGER

- **Do not operate the system until all the check points have been cleared.**
- **Measure the resistance between the ground and the terminal of the electrical components. Make sure that the electrical resistance is more than 1 MΩ. Otherwise, do not operate the system until you find the electrical leakage and you repair the electrical leakage. Do not impress the voltage on the terminals for transmission 1 and 2. (*)**
- **Pay attention to the following items while the system is running.**
 - **Do not touch any of the parts at the discharge gas side with your hands because the compressor chamber and the pipes at the discharge gas side are hot at a temperature that is higher than 90 °C.**
 - **DO NOT PUSH THE BUTTON OF THE MAGNETIC SWITCH(ES). If you do, you will cause a serious accident.**
- **Do not touch any electrical components for more than three minutes after turning OFF the main switch.**

Checking procedure

- 1 Make sure that the stop valve of the gas line and the stop valve of the liquid line are fully open.
- 2 Make sure that there is no refrigerant leakage. The flare nuts sometimes loosen because of the vibration during the transportation.
- 3 Make sure that the refrigerant piping and the electrical wiring belong to the same system. Make sure that the setting of the unit number of DSW1, DSW6 and RSW1 of indoor units correspond to the system.
- 4 Make sure that the setting of the DIP switches on the printed circuit board of the indoor units and the outdoor units are correct. Especially, pay attention to the setting of the lift between the indoor units and the outdoor units. Refer to chapter 4 "Electrical Wiring" for details.
- 5 Make sure that the switch on the main power source has been ON for more than twelve hours in order to warm the compressor oil by means of the oil heater.
- 6 Check whether or not the electrical wiring of the indoor units and the outdoor units are connected as shown in chapter 4 "Electrical Wiring".
- 7 Make sure that each wire terminal (L1,L2,L3 and N or L1 and N) is correctly connected at the power source.



NOTE

- **Make sure that the field-supplied electrical components (main switch fuse, fuse-free breaker, earth leakage breaker, wires, conduit connectors and wire terminals) have been properly selected according to the electrical data in the technical catalogue of the unit. Also, make sure that the field-supplied electrical components comply with the national codes and the local codes.**
- **Use the shielded cables for the field wiring in order to avoid the electrical noise. (The length of the shielded cable should be less than 1000 m. The size of shielded cable should comply with the local codes).**
- **Make sure that the terminals for the power supply wiring ("L1" to "L1" and "N" to "N" of each terminal board for AC 230 V and the terminals for the intermediate wires between the indoor unit and the outdoor unit (Operating Line: terminals of each terminal board for DC 12 V) match correctly. Otherwise, you may damage some components.**
- **For RAS-12HN(P/C) units, the operation may not be available within 4 hours after turning ON the power supply due to the unheated crankcase (stoppage code: d1-22). If the compressor should be within 4 hours, turn ON the power and wait for more than 30 seconds. Press PSW1 and PSW3 on the outdoor PCB simultaneously for more than 3 seconds. The forced thermo-OFF function (d1-22) is cancelled and the compressor operation is available..**

- **Check to ensure the operating temperature:**
 - **Cooling operation:**
 - ♦ **Indoor DB 21.5 °C and above,**
 - ♦ **Indoor WB 16 °C and above,**
 - ♦ **Outdoor DB 0 °C and above**
 - **Heating operation:**
 - ♦ **Indoor DB 27 °C and below.**

(*) About insulation resistance

- The insulation may lower during a test run or after being left with the main power OFF for a long time, due to refrigerant accumulation in the compressor. Check the following when the insulation resistance lowers to 1 MΩ or below, or in case that the ground-fault circuit interrupter activates.
 - 1 Remove compressor cables and measure the insulation resistance of the compressor alone. If the resistance is over 1 MΩ, other insulation failure of electric live part may exist.
 - 2 If the resistance is under 1 MΩ, remove compressor cables from the inverter PCB and turn the power ON and energize the oil heater. Measure the resistance after more than three hours of electric current application. If the insulation resistance recovers, the compressor does not have problems. In case that the resistance does not recover, compressor failure may exist. (More time may be required to apply the current depending on the conditions of air, pipe length or the refrigerant)



NOTE

To reconnect the removed compressor cables, re-caulk the terminal using a tool like longnose pliers in order that the Faston terminal does not remain loose.

- In case of Earth Leakage Breaker (ELB) activation, please confirm the rated capacity of ELB as well. Earth leakage breaker (ELB) shall be inverter compatible, and select a high-sensitive and high-speed model for sensed current rating under 30 mA (activation time within 0.1 sec).

7.2 Test run procedure using the remote control switch (PC-ART)

- 1** Turn ON the power source of the units
- Procedure for TEST RUN mode of remote control switch.
- Depress the MODE and the ←OK switches together for more than 3 seconds.
- 2**
- If TEST RUN and the counting number of the connected units to the remote control switch (for example 05) are indicated on the remote control switch, the connection of remote control cable is correct. → Go to **4**
 - If no indication appears or the number of the units indicated is smaller than the actual number of the units, some abnormalities exist. → Go to **3**

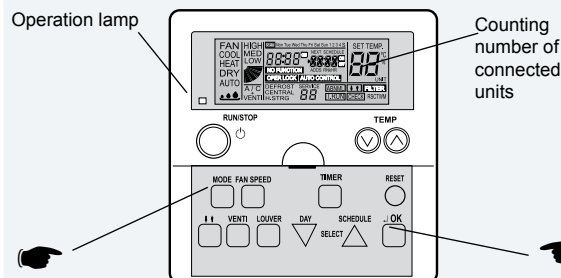

Remote control switch indication	Wrong portions	Inspection points after the power source OFF
No indication	The power source of outdoor unit is not turned ON.	1 Connecting points of remote control cable, terminal board of remote control switch and indoor unit. 2 Contact of terminals of remote control cable.
	The connection of the remote control cable is incorrect.	
3 Counting number of connected units is incorrect	The connecting wires of power supply line are incorrect or loosened.	3 Connection order of each terminal board. 4 Screw fastening of each terminal boards.
	The power source of outdoor unit is not turned ON.	
	The operating line wiring between indoor unit and outdoor unit is not connected. The connection of control cables between each indoor units are incorrect. (When one remote control switch controls multiple units).	

Back to **1** after checking

- 4** Select TEST RUNNING MODE by depressing MODE Switch (COOL OR HEAT)
- Depress RUN/STOP switch.
- The TEST RUN operation will be started. (The 2 hours OFF-TIMER will be set and the TEST RUN operation will be finished after 2 hours unit operation or by depressing the RUN/STOP switch again).





NOTE

- TEST RUN operation ignores the temperature limitation and ambient temperature during heating operation to have a continuous operation, but the protections are alive. Therefore, the protection may activate when the heating TEST RUN operation is performed in high ambient temperature.**
- TEST RUN operation time can be modified / increased depressing the time switch in the Remote Control.**

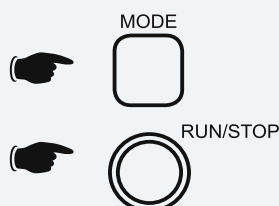
- 5**
- If the unit do not start or the operation lamp on the remote control switch is flickered, some abnormalities exist. →Go to **6**



Remote control switch indication	Unit condition	Wrong portions	Inspection points after power source OFF		
<p>6</p> <p>The operation lamp flickers. (1 time/1 sec.) and the unit number and alarm code 03 flicker.</p>	The unit does not start.	<p>The power source of outdoor unit is not turned ON.</p> <p>The connecting wires of operating line are incorrect or loosened.</p>	<p>1 Connecting order of each terminal boards.</p> <p>2 Screw fastening of each terminal boards.</p>		
			<p> NOTE</p> <p><i>Recovering method of FUSE for operating circuit. There is a fuse (FUSE4 on indoor unit PCB1, EF1 on outdoor unit PCB1) to protect operating circuit on the PCB, when the power lines are connected to operating lines. If fuse is melted, operating circuit can be recovered once by setting the dip switch on the PCB as shown in 7</i></p>		
			<p>The operation lamp flickers. (1 time/2 sec.)</p>	<p>Remote control cable is broken.</p> <p>Contact of connectors is not good.</p> <p>The connection of remote control cable is incorrect</p>	<p>This is the same as item 3 1 and 2</p>
			<p>Indication of flicker except above</p>	<p>The unit does not start, or start once and then stops</p>	<p>The connection of thermostat or other connectors are incorrect. Tripping of protector exists, or else.</p>
<p>The operation lamp flickers. (1 Time/1s)</p> <p>Unit number <i>00</i>, alarm code <i>dd</i> and unit code <i>EDD</i> flicker</p>	The unit does not start.	The connection of the remote control cable between indoor units is incorrect.	Check by the abnormality mode table in the Technical Catalog (Do it by service people).		
Back to 1 after checking					
<p>7</p> <p>Instructions for the recovery when the fuse of the transmission circuit is blown out:</p> <p>1 Correct the wiring to the terminal board.</p> <p>2 Set pin 2 of DSW7 on the indoor units PCB to ON Only for RPK-(0.8-1.5): set DSW7 on the indoor unit PCB ON</p>		Except RPK(0.8/1.5)	Only RPK-(0.8/1.5)		
					

7.3 Test run procedure using the remote control switch (PC-ARF)

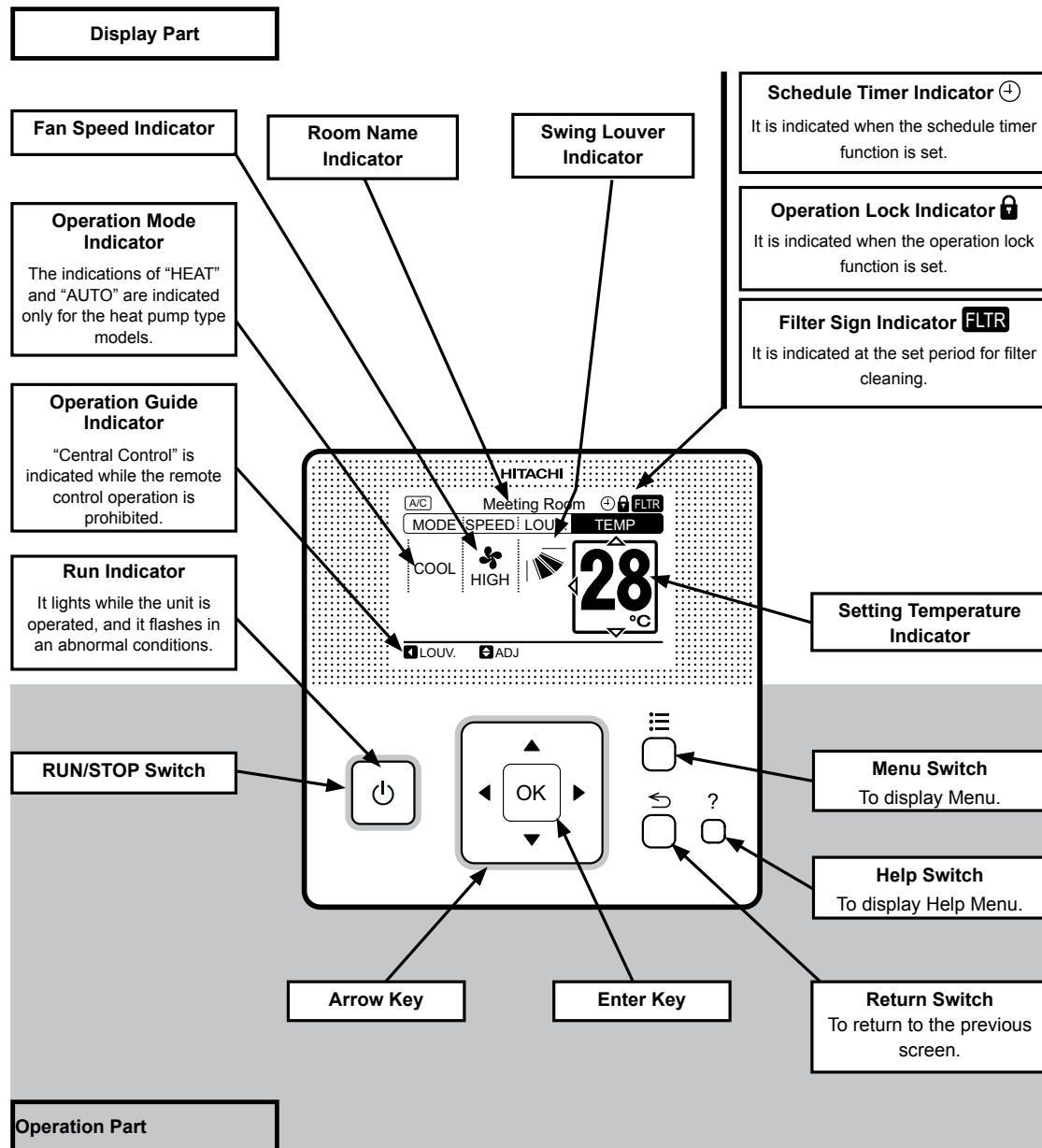

- 1 Turn ON the power supply for all the indoor units.
- 2 For the models with the auto-address function, wait for 3 minutes approximately. The addressing is automatically performed. (There is a case that 5 minutes is required according to the setting condition.) After that, select using language from "Menu". Refer to the operation manual for details.
- 3 Press and hold "☰" (menu) and "↶" (return) simultaneously for at least 3 seconds.

a. The test run menu will be displayed.

Test run screen

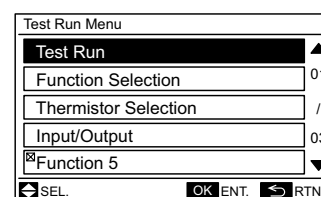

- b. Select "Test Run" and press "OK". The test run settings will be displayed.

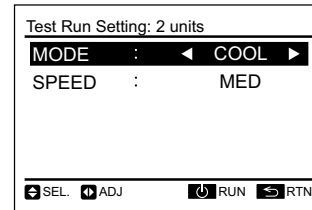

When "00" is indicated, the auto-address function may be performing. Cancel "Test Run" mode and set it again.

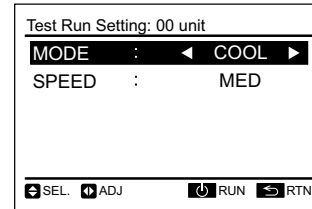

- 4 The total number of the indoor units connected is indicated on the LCD (liquid crystal display). The case of the twin combination (one (1) set with two (2) indoor units) is indicated "2 units", and the triple combination (one (1) set with three (3) indoor units) is indicated "3 units".

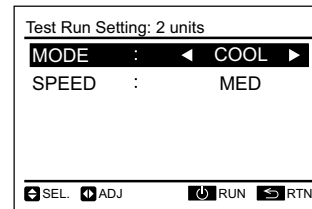

- c. If the indicated number is not equal to the actual connected number of indoor unit, the auto-address function is not performed correctly due to incorrect wiring, the electric noise or etc. Turn OFF the power supply and correct the wiring after checking the following points; (Do not repeat turning ON and OFF within 10 seconds.)
- Power supply for indoor unit is not turned ON or incorrect wiring.
 - Incorrect connection of connecting cable between indoor units or incorrect connection of controller cable.
 - Incorrect setting of rotary switch and dip switch (the setting is overlapped) on the indoor units PCB.
- d. Press "⏻" (run/stop) to start the test run.
- e. Press "△ ▽ ◀ ▶" and set each item.



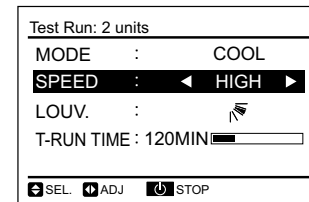

- 5 Press "⏻" (run/stop). Start the test run when indicating the air flow volume "HIGH" (default setting) and light the operation lamp. At this time, 2-hour OFF timer will be set automatically..

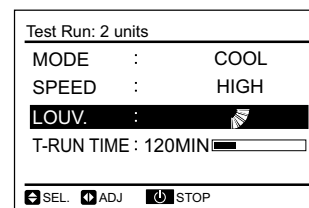

- 6 Press "△" or "▽", select "LOUV." and select (auto swing) by pressing "◀" or "▶". The auto swing operation will be started. Check the operating sound at the louvers. If abnormal sound is not generated, press "◀" or "▶" again to stop the auto swing operation.



- 7 The temperature detections by the thermistors are invalid though the protection devices are valid during the test run.
- 8 For SET-FREE Series: According to the label "Checking of Outdoor Unit by 7-Segment Display on PCB1" attached to the rear side of the front cover of the outdoor unit, check temperature, pressure and the operation frequency, and connected indoor unit numbers by 7-segment displays.

- 9 To finish the test run, press “” (run/stop) again or pass over the set test run time. When changing the test run time, press “” or “” to select “T-RUN TIME”. Then, set the test run time (30 to 600 minutes) by pressing “” or “”

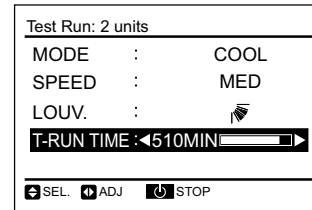

- The RUN indicator on the remote control switch flashes when some abnormalities such as protection devices activated occur during the test run as well as the RUN indicator (orange) on the indoor unit flashes (0.5 second ON/ 0.5 second OFF). Additionally, the alarm code, the unit model code and connected number of indoor units will be displayed on the LCD as shown in the figure below. If the RUN indicator on PC-ARF flashes (2 seconds ON/ 2 seconds OFF), it may be a failure in the transmission between the indoor unit and the remote control switch (loosening of connector, disconnecting wiring or breaking wire, etc.). In this case, check the item 8.3 “Alarm Code” and perform for troubleshooting. Consult to authorized service engineers if abnormality can not be recovered.

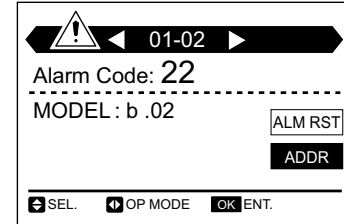

Refrigerant Cycle No. of Indoor Unit which Abnormality Occurs

Indoor Unit No. which Abnormality Occurs

◀ 01 - 02 ▶

Alarm Code: 22

MODEL : b .02

Unit Model Code

Alarm Code No.

Total No. of Indoor Unit in Same Refrigerant Cycle as One that Abnormality Occurs

7.4 Test run procedure using the wireless remote control switch (PC-LH3A/B)



NOTE

If the wired remote control switch is used or if multiple units (SET-FREE, DC INVERTER and utopia series) are operating simultaneously, you cannot perform the test run by means of the remote control switch. If that is the case, perform the test run by means of the wired remote control switch.

- 1 Perform the test run after completing the installation.
 - a. Set the batteries for the remote control switch.
 - b. Turn ON the power source of the indoor units and the outdoor units.
 - c. The yellow '☺' LED on the receiver of the indoor unit flickers (0.25 seconds ON ↔ 0.25 seconds OFF). Then, the yellow LED turns OFF. While the LED is flickering, the unit will not operate because the unit is initializing.
- 2 Set the TEST RUN mode by pressing the SET switch and the OFF TIME switch simultaneously for more than three seconds. The LCD should look like the LCD on the right figure. The TEST RUN mode is not operating
- 3 Set the operation mode by pressing the MODE switch. The TEST RUN mode is operating.

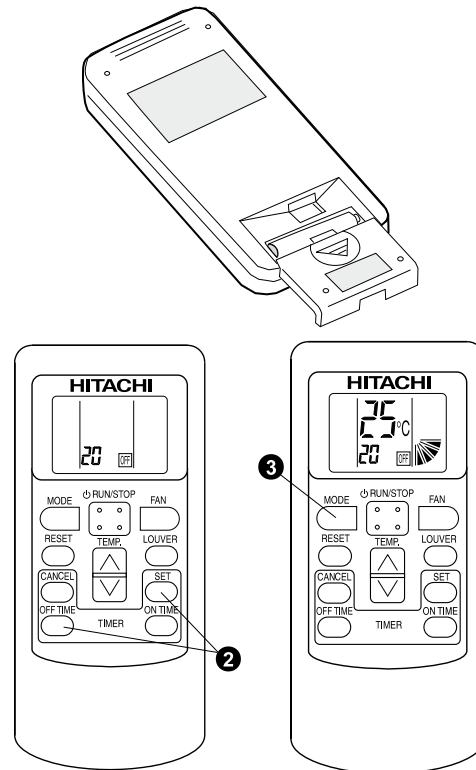

- 4 Operate the test run by pointing the transmitter towards the receiver of the indoor unit. Then, press the RUN/STOP switch. When the indoor unit receives the commands, the yellow '☺' LED of the receiver will turn on briefly. Make sure that the commands are received well and the selected mode (3) is set correctly. In the TEST RUN mode, the red RUN LED of the receiver is turned ON and the green TIMER LED flickers (0.5 seconds ON ↔ 0.5 seconds OFF) (*2). Then, the timer switches off for two hours.



NOTE

- **If the yellow '☺' LED does not turn ON, the commands from the remote control switch may not have reached the receiver. Send the commands again.**
 - **(*2) In the case of the RPK model, the TIMER LED is turned OFF.**
- 5 Adjust the angle of the air grille as follows. The air louver has a mechanism for the auto-swing function. Do not move the louver by hand forcefully.
 - a. Select the FAN mode by pressing the MODE switch.
 - b. Set the louver angle by pressing the LOUVER switch.
 - 6 Stop the test run (normal)
 - a. The test run stops automatically after two hours.
 - b. You stop the test run by pressing the RUN/STOP switch again. After the test run has finished, check that the red RUN LED and the green TIMER LED turn OFF.
 - 7 Stop the test run (abnormal) for the PC-ALHD/PC-ALHZ. If you cannot use the PC-LH3A because of battery shortage or any other reason, perform the emergency operation as follows.
 - a. COOL switch: Press the COOL switch in order to start the cooling process. Press the COOL switch again in order to stop the cooling process.
 - b. HEAT switch: Press the HEAT switch in order to start the heating process. Press the HEAT switch again in order to stop the heating process.



NOTE

During the emergency operation, the yellow LED blinks (0.5 seconds ON / 0.5 seconds OFF).

c. Alarm code display

- If some malfunction occurs because of the activation of a safety device or any other reason, the red RUN LED blinks (0.5 seconds ON / 0.5 seconds OFF).
- Refer to section *Alarm codes* on chapter *Troubleshooting*.
- The alarm code displays the number of blinks of the green DEF LED and the yellow FILTER LED as shown below:
- Green DEF LED: Digit 2 of the alarm code blinks.
- Yellow FILTER LED: Digit 1 of the alarm code blinks. (Alphabet code: A=10 blinks, B=11 blinks, C=12 blinks, etc.).

Example:

Alarm code:

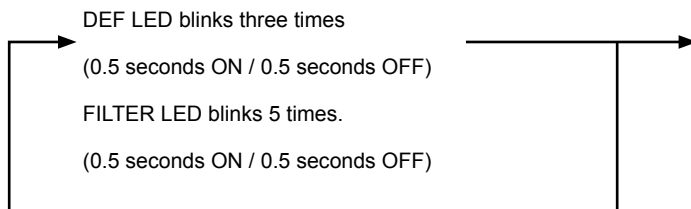
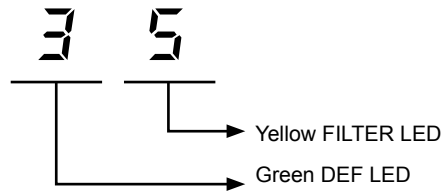

The red RUN LED (1 second ON / 1 second OFF) means that there is an abnormal transmission between the indoor units and the outdoor unit.

7.5 Test run procedure from the outdoor unit side

The test run procedure from the outdoor unit side is shown below.

You can set this DIP switch while the power source is ON.







Setting of dip switch

DSW1	
	<ol style="list-style-type: none"> 1 Test Run 2 COOL/HEAT (Setting ON: Heat Operation) 3 COOL / HEAT intermediate season 4 Manual Compressor stop

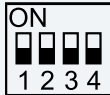

DANGER

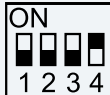
- **Do not touch any other electrical components while you are setting the switches on the PCB.**
- **Do not attach or detach the service access panel when the power source for the outdoor unit is ON and the outdoor unit is operating.**
- **Set all the DIP switches of DSW1 to OFF after completing the test run.**

Operation	Dip Switch Setting	Operation	Remarks
Test Run	<ol style="list-style-type: none"> 1 Setting of Operation Mode: Cooling: Set DSW1-2 OFF.  Heating: Set DSW1-2 ON.  	<ol style="list-style-type: none"> 1 The indoor unit automatically start to operate when the test run of the outdoor unit is set. 2 The ON/OFF operation can be performed from the remote control switch or DSW1-1 of the outdoor unit. 3 Continuous operation during 2 hours is performed without Thermo-OFF. <p>NOTE</p> <ul style="list-style-type: none"> • TEST RUN operation time can be increased depressing the time switch in the Remote Control. • If is setting DSW1-3 ON, cooling/heating intermediate season mode is activated. 	<ul style="list-style-type: none"> • Take care that the indoor units start operation in accord with the test run operation of the outdoor unit. • The test run is started from the outdoor unit and stopped from the remote control switch, the test run function of the remote control switch is cancelled. However, the test run function of the outdoor unit is not cancelled • In case that the plural indoor units are connected with one remote control switch, all the units start test run operation at the same time, therefore, turn the power source OFF for the indoor units not to operate test run. In this case, the "TEST RUN" indication of the remote control switch may flicker, and this is not abnormal. • The setting of DSW1 is not required for the test run from the remote control switch.
	<ol style="list-style-type: none"> 2 Starting Test Run: Set DSW1-1 ON and the operation is started after a few ~20 seconds. <div style="display: flex; justify-content: space-around;"> <div style="text-align: center;"> Cooling  </div> <div style="text-align: center;"> Heating  </div> </div> 		
Manual OFF of Compressor	<ol style="list-style-type: none"> 1 Setting: Compressor Manual OFF: Set DSW1-4 ON.  Compressor ON: Set DSW1-4 OFF.  	<ol style="list-style-type: none"> 1 When DSW1-4 is ON during compressor operation, the compressor stops to operate immediately and the indoor unit is under the condition of Thermo-OFF. 2 When DSW1-4 is OFF, the compressor starts to operate after the cancellation of 3-minutes guard. 	<ul style="list-style-type: none"> • Do not repeat compressor ON/OFF frequently.

Manual Defrost	<p>① Manual Defrost Operation Starts</p> <p>Press PSW1 for more than 3 seconds during heating operation, the defrost operation is started after 2 minutes. This function is not available within 5 minutes after starting heating operation</p> <p>② Manual Defrost Operation Finishes</p> <p>Defrost operation is automatically ended and the heating operation is started.</p>	<p>① Defrost operation is available regardless of frosting condition and total time of heating operation.</p> <p>② Defrost operation is not performed when the temperature of outdoor heat exchanger is higher than 10°C, high pressure is higher than 3.3 MPa (33kgf/cm²G) or Thermo-OFF.</p>	<ul style="list-style-type: none"> Do not repeat defrost operation frequently.
----------------	--	---	---

NOTE

In case of RAS-(2-2.5)HVNP or RAS-3HVNC operation is performed by DSW301 on the PCB of the outdoor unit instead of DSW1.

7.6 Check list

7.6.1 Check list on test run

MODEL:	
SERIAL No.	
COMPRESSOR MFG No.	
NAME AND ADDRESS OF CUSTOMER:	
DATE:	

- 1 Is the rotation direction of the indoor coil fan correct? _____
- 2 Is the rotation direction of the outdoor coil fan correct? _____
- 3 Is there any abnormal compressor sound? _____
- 4 Has the unit been operating for at least twenty (20) minutes? _____
- 5 Check the room temperature:

Inlet	No 1	DB ____ °C	No 2	DB ____ °C	No 3	DB ____ °C	No 4	DB ____ °C
		WB ____ °C				WB ____ °C		
Outlet		DB ____ °C		DB ____ °C		DB ____ °C		DB ____ °C
		WB ____ °C		WB ____ °C		WB ____ °C		WB ____ °C
Inlet	No 5	DB ____ °C	No 6	DB ____ °C	No 7	DB ____ °C	No 8	DB ____ °C
		WB ____ °C				WB ____ °C		
Outlet		DB ____ °C		DB ____ °C		DB ____ °C		DB ____ °C
		WB ____ °C		WB ____ °C		WB ____ °C		WB ____ °C

- 6 Check the outdoor ambient temperature:

Inlet	DB ____ °C
	WB ____ °C
Outlet	DB ____ °C
	WB ____ °C

- 7 Check the refrigerant temperature: Operating mode (cool or heat).

Discharge gas temperature	Td = ____ °C
Liquid pipe temperature	Te = ____ °C

- 8 Check the pressure:

Discharge pressure	Pd = ____ kg/cm ² G
Suction pressure	Ps = ____ kg/cm ² G

- 9 Check the voltage:

Rated voltage	____ V	—	—
Operating voltage	L1-L2 ____ V	L1-L3 ____ V	L2-L3 ____ V
Starting voltage	____ V	—	—
Phase imbalance	1-(V/m) =	—	—

- 10 Check the compressor input running current

Input	____ kW
Running current	____ A

- 11 Is the refrigerant charge adequate? _____
- 12 Do the operation control devices operate correctly? _____
- 13 Do the safety devices operate correctly? _____
- 14 Has the unit been checked for refrigerant leakage? _____
- 15 Is the unit clean inside and outside? _____
- 16 Are all the cabinet panels fixed? _____
- 17 Are all the cabinet panels free from rattles? _____
- 18 Is the filter clean? _____
- 19 Is the heat exchanger clean? _____
- 20 Are the stop valves open? _____

21 Does the drain water flow smoothly from the drain pipe? _____

7.6.2 Check list on compressor

CLIENT:		MODEL:	DATE:	
Serial N°:		Production date:	Checker:	
N°	Check item	Check method	Result	Remarks
1	Is THM9 correctly connected? THM9: Discharge gas thermistor	(1) Is wire of thermistor correctly connected by viewing? (2) Check to ensure the 7-segment indication of Td when comp. is operating. Td: Temperature of THM9		
2	Is thermistor THM9 disconnected?	(1) Check to ensure that thermistor on the top of comp. is correctly mounted by viewing? (2) Check to ensure that actually measured temp. is the same as the indication during check mode.		
3	Is current sensor faulty?	(1) Check to ensure that indication A1 and A2 are 0 during compressor stopping.		
4	Is current sensing part on PCB2 faulty?	(2) Check to ensure that indication A1 and A2 are not 0 during compressor running.		
5	Is the direction of current sensor (CTU, CTV) reverse?	Check the direction => by viewing.		
6	Are power source wires, U and V inserted correctly into current sensor?	Check to ensure that wires are correctly inserted.		
7	Is exp. valve (MV1) correctly connected?	Check to ensure that MV1 to CN5A is correctly connected.		
8	Is exp. valve (MV1) coil correctly connected?	Check to ensure that each coil is correctly mounted on the valve.		
9	Are the refrigeration cycle and electrical wiring system incorrectly connected?	Check to ensure that refrigerant is flowing into indoor units by operating one refrigerating cycle only from the outdoor unit.		
10	Is opening of exp. valve completely closed (locked)?	Check the following by the check mode of outdoor units. (1) Liquid pipe temp. (TL) < air intake temp. (Ti) during cooling operation (2) Liquid pipe temp. (TL) > air intake temp. (Ti) during heating operation		
11	Is opening of exp. valve fully opened (locked)?	Check to ensure that liquid pipe temp. is lower than air intake temp. of stopping indoor unit when other indoor units are operating under cooling operation		
12	Are the contacts for comp. magnetic switch CMC1 faulty?	Check the surface of each contact (L1, L2 and L3) by viewing.		
13	Is there any voltage abnormality among L1-L2, L2-L3 and L3- L1?	Check to ensure that voltage imbalance is smaller than 3%. Please note that power source voltage must be within 380V or 220V+10%.		
14	Is the comp. oil acidified during compressor motor burning?	Check to ensure that the oil color is not black.		

Additional information for “Check list on compressor”

Check item	Additional information (mechanism of compressor failure)
1 & 2	The liquid refrigerant return volume to the compressor is controlled by the discharge gas temperature Td when compressor is operating. If Td thermistor is disconnected, the liquid refrigerant return volume will become small by detecting the temperature even if the actual discharge gas temperature is high. Therefore, this abnormal overheating by detecting the temperature operation will result in insulation failure of the motor winding.
3 & 4	Overcurrent control (operating frequency control) is performed by detecting current by the PCB2. In this case, winding insulation failure will occur, since control is not available in spite of actually high current.
5 & 6	The current sensor checks phase and adjusts output electrical wave in addition to the above mentioned items. If fault occurs, the output electrical wave becomes unstable giving stress to the motor winding, resulting in winding insulation failure.
7 & 8	During a cooling operation, SH is controlled by MV of each indoor units. During a heating operation, Td is controlled by MV1. If expansion valves are incorrectly connected, correct control is not available, resulting in compressor seizure depending on liquid refrigerant returning conditions or motor winding insulation failure depending on overheating conditions.
9	If the refrigeration cycle and electrical system are incorrectly connected, abnormally low suction pressure operation is maintained or abnormally high discharge pressure operation is maintained, resulting in giving stress to the compressor, since their correct control is not available.
10	If the expansion valve and electrical system are incorrectly connected, abnormally low suction pressure operation is maintained or abnormally high discharge pressure operation is maintained, resulting in giving stress to the compressor, since their correct control is not available.
11	The compressor may be locked due to the liquid return operation during the cooling operation .
12	In the case that the contacting resistance becomes big, voltage imbalance among each phase will cause abnormal overcurrent.
13	In this case, overcurrent will occur, efficiency will decrease or the motor winding will be excessively heated.
14	In the case, it will result in motor burning or compressor failure

8 . Troubleshooting

Index

8.1.	Initial troubleshooting	184
8.1.1.	Checking by means of the 7-segment display	184
8.1.2.	Failure of the power supply to the indoor unit and the remote control switch.....	185
8.1.3.	Abnormal transmission between the remote control switch and the indoor unit.....	186
8.1.4.	Abnormal operation of the devices	186
8.2.	Troubleshooting procedure	192
8.2.1.	Alarm display	192
8.2.2.	Alarm codes for the outdoor and indoor units.....	193
8.2.3.	Troubleshooting by alarm code for the outdoor and indoor units	194
8.2.4.	Alarm codes for the KPI (E/H/X)3E Series and DX Interface	252
8.3.	Troubleshooting in check mode	253
8.3.1.	Troubleshooting using the remote controller PC-ART	253
8.3.2.	Troubleshooting using the remote controller PC-ARF	263
8.3.3.	Troubleshooting using the 7 segment display	268
8.4.	Checking procedure for main parts	277
8.4.1.	Procedure for checking the DIP-IPM inverter for indoor and outdoor units.....	277
8.4.2.	Checking capacitors CB1 & CB2.....	283
8.4.3.	Fault diagnosis of DC fan motor.	284
8.4.4.	Checking procedure for the electronic expansion valve for indoor and outdoor units.....	285
8.4.5.	Checking procedure for AC fan motor	285
8.4.6.	Checking procedure for other parts.....	286

8.1 Initial troubleshooting

8.1.1 Checking by means of the 7-segment display

Simple checking procedure by means of the 7-segment display

- 1 Turn on all the indoor units which are connected to the outdoor unit.
- 2 Turn on the outdoor unit
- 3 Auto-addressing starts. (Outdoor unit printed circuit board PCB1).

During the auto-addressing, you can check the following items by means of the 7-segment display of the outdoor unit.

- Disconnection of the power supply to the Indoor Unit.
- Disconnection of the operating line between the outdoor and the indoor units.
- Duplication of the Indoor Unit number.
- **Normal case:**
The 7-segment display of the outdoor unit is not indicated.

- **Abnormal case:**

If there is something wrong, the 7-segment display of the outdoor unit displays the following indications:

Cause	Indication	Remarks
A. The indoor units are not supplied with power.	□□	continues to flash after 30 seconds.
B. Disconnection of the operating line between the outdoor units and the indoor units.	□□	continues to flash after 30 seconds.
C. Duplicated settings of the indoor unit number on the rotary switch RSW (Refer to the section Troubleshooting by alarm code , see the description of the alarm code "35").	—	—

8.1.2 Failure of the power supply to the indoor unit and the remote control switch

- The LED and the LCD are not indicated.
- Not operated

If the fuses are blown out or a breaker is activated, investigate the cause of the overcurrent and take the necessary action.

Phenomenon	Cause	Check item	Action (Turn OFF the main switch)
Power failure or power is not ON		Measure the voltage by means of the voltmeter	Supply the power
Blown out fuse or activation of the breaker at the power source	Short circuit supplied between the wires	Check for any uncovered part of the wires	Remove the cause of the short circuit and replace the fuse
	Short circuit of the wires to earth	Measure the insulation resistance	Remove the cause of the short circuit and replace the fuse
	Failure of indoor unit fan motor	Measure resistance between wires and insulation resistance	Replace the fan motor and fuse
Blown out fuse at the control circuit	Short circuit supplied between the wires	Check for any uncovered part of the wires	Remove the cause of the short circuit and replace the fuse
	Short circuit of the control circuit to earth	Measure the insulation resistance	Remove the cause of the short circuit and replace the fuse
	Failure of indoor unit fan motor	Measure the insulation resistance	Remove the cause of the short circuit and replace the fuse
Failure of the transformer at the indoor unit side		Measure the voltage at the secondary side	Replace the transformer
Disconnected cable of the remote control switch		Connect the cable	Replace the cable or repair the cable
Insufficient contacting at the connectors of the remote control switch	Insufficient connection or incorrect connection of the indoor unit PCB	Check the connectors	Correctly connect the connector
	Insufficient connection or incorrect connection of the indoor unit PCB in the remote control switch		
Failure of the remote control switch		Check the remote control switch by means of the self-check mode *1)	Replace the remote control switch if it failed
Failure of PCB	Unconnected wires to PCB	Check the connectors	Correctly connect the wires
	Failure of PCB	Check PCB by means of the self-check mode *2)	Replace PCB if it failed
Incorrect wiring connection		Take action according to the procedure that is displayed in "TEST RUN"	

NOTE

- *1): Refer to section [Self-checking of the remote control switch](#).
- *2): Refer to section [Self-checking procedure of PCB by means of the Remote Control Switch](#).

8.1.3 Abnormal transmission between the remote control switch and the indoor unit

- **RUN LED on the remote control switch:**

Flickering every 2 seconds.

Phenomenon	Cause	Check item	Action (Turn OFF the main switch)
Disconnection or insufficient contacting of the remote control cable		Check the cable and the connections	Repair the cable or connect the cable
Failure of the remote control switch		Check the remote control switch by means of the self-check mode *1)	Replace the remote control switch if the remote control switch is faulty
Failure of PCB (in the indoor unit and the remote control switch)	Disconnected wire to PCB	Check the connectors	Correctly connect the wires
	Failure of PCB	Check PCB by means of the self-check mode *2)	Replace PCB if it failed



NOTE

- *1): Refer to section [Self-checking of the remote control switch](#).
- *2): Refer to section [Self-checking procedure of PCB by means of the Remote Control Switch](#).

8.1.4 Abnormal operation of the devices

Phenomenon	Cause		Check item	Action (Turn OFF the main switch)
RUN LED is ON and the LCD is indicated. However, the system does not operate (For example, the indoor fan, the outdoor fan or the compressor does not operate)	Failure of the indoor unit fan motor	Disconnected coil	Measure the coil resistance by means of the tester	Replace the Indoor unit fan motor
		Burnt-out coil	Measure the insulation resistance	
	Failure of the outdoor unit fan motor	Disconnected coil	Measure the coil resistance by means of the tester	Replace the outdoor unit fan motor
		Burnt-out coil	Measure the insulation resistance	
	Failure of the magnetic switch for the outdoor unit fan motor	Insufficient contacting	Measure the voltage between the contacting parts	Replace PCB for the outdoor unit
	Failure of the comp. motor		Measure the resistance between two wires	Replace the compressor
	Failure of the comp.		Check for an abnormal sound from the Comp.	
	Failure of the magnetic switch for comp.	Insufficient contacting	Check that the magnetic switch activates correctly or not	Replace the magnetic switch
	Failure of one of PCBs	Disconnected wiring to PCB	Check the connections	Correctly connect the wiring
		Failure of PCB	Check PCB by means of the self-check mode *1)	Replace PCB if it failed

Phenomenon	Cause		Check item	Action (Turn OFF the main switch)
The Comp. does not stop or start even if the setting temperature on the LCD changes to *3)	Failure of air inlet thermistor	Failure of thermistor	Check it by self-checking *2)	Replace or correctly connect the wires if Abnormal Operation exists
		Disconnection of thermistor		
	Abnormal operation of the remote control switch cord			
	Failure of the indoor unit PCB		Check PCB by means of the self-check mode *1)	Replace PCB if it failed
	Incorrect optional setting		Check the setting condition of "remote control thermostat" by means of the optional setting Setting and control: "00": Control by means of the indoor thermistor for the suction air "01": Control by means of the thermostat of the remote control switch "02": Control by means of the average value of the indoor thermistor for the suction air and the thermostat of the remote control switch	If the thermostat of the remote control switch is not used, set at "00"
Incorrect Input/Output setting		Check setting condition of "i1" and "i2" by Input/Output setting. * Setting and Control: "01": Room thermostat (Cooling) "02": Room thermostat (Heating)	In case that room thermostat is not used, set for input signal actually used. If no signal is used, set at "00"	
Indoor fan speed does not change	Failure of the Discharge Air Temp. Thermistor	Failure of the Thermistor	Check the Thermistor by means of the self-check mode *2)	Replace or Correctly connect the wiring when it is abnormal
		Disconnected Wire of the Thermistor		
	Failure of the Remote Control Switch		Check it by means of the self-check mode *1)	Replace if it failed
Failure of PCB for the indoor unit			Replace if PCB fails	
No defrost operation mode is available during the heating process or the defrost operation continues	Failure of thermistor for outdoor evaporating temp. during heating	Failure of thermistor	Replace or correctly connect when it is abnormal	
		Disconnected wire of thermistor		
	Failure of 4-way valve	Disconnected 4-way valve coil	Measure the resistance of coil	Replace the 4-way valve
		Incorrect activation of 4-way valve	Enforced power supply	
	Disconnected control wires between indoor unit and outdoor unit		Check the connectors	Correctly connect the wiring
	Failure of the outdoor units of PCB	Disconnected wiring to PCB	Check the connectors	Correctly connect the wiring
		Failure of PCB	Check PCB by means of the self-check mode *1)	Replace PCB when the check mode is not available
Failure of the Indoor Unit of PCB	Disconnected wiring to PCB	Check the connectors	Correctly connect the wiring	
	Failure of the PCB			
The LED and the LCD on the remote control switch remain ON	Failure of PCB in the indoor unit or the remote control switch		Check PCB by means of the self-check mode *1)	Replace if PCB fails

Phenomenon	Cause	Check item	Action (Turn OFF the main switch)	
Insufficient cooling process	Indoor cool load is greater than the cooling capacity	Calculate the cool load	Use a bigger unit	
	Excessively low suction pressure	Gas leakage or shortage of refrigerant	Measure superheat	Correctly charge the refrigerant after repairing the gas leakage
		Excessively small diameter tube or long piping	Measure and check the field-supplied pipes	Use the correct pipes
		Incorrect activation of the check valve of the outdoor unit	Check whether or not the temp. difference exists before/after the check valve	Replace the check valve for the outdoor unit
		Failure or malfunction of the expansion valve	Check for clogging	Remove the clogging
				Check the connection cord and the connector
			Is there an operation sound from the coil?	Replace the coil
			Is the thermistor on the compressor normal?	Replace the thermistor
			Is the thermistor installed correctly on compressor?	Correctly install the thermistor
			Clogged strainer in the indoor unit; clogging at the low pressure piping	Check the temp. difference at the inlet and the outlet of the strainer
		Clogging at the low pressure piping	Check the temp. difference	Remove the clogging
		Insufficient air flow to the indoor unit heat exchanger	Check for clogged air filter	Clean the air filter
			Check for an obstacle at the inlet or the outlet	Remove the obstacles
		Excessively low air temp. to the indoor unit heat exchanger	Insufficient speed of the indoor unit fan motor?	Replace the fan motor
Short-circuited indoor unit air?	Remove the cause of the short-circuited air			

Phenomenon	Cause		Check item	Action (Turn OFF the main switch)
Insufficient cooling process	Excessively high discharge pressure	Insufficient air flow to the outdoor unit heat exchanger	Clogging of the outdoor unit heat exchanger?	Remove the clogging
			Obstacles at the inlet or the outlet of the outdoor unit heat exchanger	Remove the obstacles
			Is the service area for the outdoor unit sufficient?	Secure the service area
			Correct fan speed?	Replace the fan motor
		Excessively high air temp. to the outdoor unit heat exchanger	Short-circuited air to the outdoor unit?	Remove the cause of the short-circuited air
			Any other heat load near the outdoor unit?	Remove the heat source
		Excessively charged refrigerant	Expansion valve opening	Correctly charge the refrigerant
		Non-condensate gas in cycle	Check each temp. and each pressure	Charge the refrigerant after the vacuum pumping
		Clogging of the discharge piping	Check for clogging	Remove the clogging
		Failure or malfunction of the expansion valve	Check for clogging	Remove the clogging
			Check the connection cord and the connector	Replace the connector
			Is there an operation sound from the coil?	Replace the coil
	Is the thermistor on the compressor normal?		Replace the thermistor	
	Is the thermistor installed correctly on the compressor?		Correctly install the thermistor	
	Malfunction or internal leakage of the 4-way valve		Check the temp. difference at the inlet and the outlet of the 4-way valve	Replace the 4-way valve
	Excessively low suction pressure	Malfunction or internal leakage of the 4-way valve	Check the Temp. Difference between the Inlet and the Outlet of 4-Way Valve	Replace the 4-way valve
		Failure of solenoid valve for bypass	Check refrigerant leakage of solenoid valve	Replace solenoid valve
	Discharge temp. of the indoor unit is unstable		Check the expansion valve of the indoor unit in the same system	Replace the failed expansion valve of the indoor unit

Phenomenon	Cause	Check item	Action (Turn OFF the main switch)	
Insufficient heating process	Indoor heat load is greater than the heating capacity	Calculate the heat load	Replace the unit with a bigger unit	
	Excessively low suction pressure	Gas leakage or insufficient refrigerant charge	Measure superheat	Correctly charge the refrigerant after the gas leakage check and repairing
		Excessively small diameter or long piping	Measure the field supplied piping	Use the specified pipes
		Failure or malfunction of the expansion valve	Check for clogging	Remove the clogging
			Check the connection cord and the connector	Replace the connector
			Is there an operation sound from the coil?	Replace the coil
			Is the thermistor on the compressor normal?	Replace the thermistor
			Is the thermistor installed correctly on compressor?	Correctly install the thermistor
		Clogging of I.U./O.U. strainer	Check the temp. difference between the inlet and the outlet of strainer	Replace the strainer for the outdoor unit or the indoor unit
		Clogging of suction piping	Check the temp. difference of each part	Remove the clogging
		Insufficient air flow through the outdoor unit heat exchanger	Is the outdoor unit heat exchanger clogged?	Remove the clogging
			Are there any obstacles at the inlet or the outlet of outdoor unit?	Remove the obstacles
			Is the service area for the outdoor unit sufficient?	Secure a sufficient service area
			Check the speed of the outdoor unit fan	Replace the fan motor
		Excessively low air temp. through the outdoor unit heat exchanger	Check for any short-circuited air to the outdoor unit	Remove the cause of the short-circuited air
	Defrosting is insufficiently completed	Check the thermistor for the defrost operation	Replace the thermistor for the defrost operation	
	Excessively high discharge pressure	Insufficient air flow to the indoor unit heat exchanger	Check the filter for a clogging	Remove the clogging
			Check for any obstacles at the inlet or the outlet of the indoor unit	Remove the obstacles
			Check the indoor fan speed	Replace the fan motor
		Excessively high air temp. to the indoor unit heat exchanger	Check whether or not the short-circuited air exists	Remove the cause of the short-circuited air
		Excessively charged refrigerant	Check the refrigerant quantity *4)	Correctly charge the refrigerant
		Non-condensate gas in ref. cycle	Check the refrigerant quantity *4)	Recharge the refrigerant after the vacuum pumping
	Clogging of the discharge pr. piping	Check for clogging	Remove the clogging	
	Malfunction or internal leakage of the 4-way valve	Check the temp. difference at the inlet and the outlet of the 4-way valve	Replace the 4-way valve	
	Malfunction of the check valve of the outdoor unit	Check the temp. difference at the inlet and the outlet of the check valve	Replace the check valve	
	Excessively high suction pressure	Malfunction or internal leakage of 4-way valve	Check the temp. difference at the inlet and the outlet of the 4-way valve	Replace the 4-way valve
	Discharge temp. of the indoor unit is unstable	Check the expansion valve of the indoor unit in the same system	Replace the failed expansion valve of the indoor unit	

Phenomenon	Cause	Check item	Action (Turn OFF the main switch)	
Cooling or heating process with an abnormal sound	Foreign particles inside of the fan casing	Visually inspect it	Remove the foreign particles	
	Indoor unit fan runner is hitting the casing	Visually inspect it	Adjust the position of the fan runner	
	Outdoor unit propeller fan is hitting the shroud	Visually inspect it	Adjust the position of the propeller fan	
	Abnormal sound from the compressor	Faulty Installation	Check that each part is tightly fixed	Tightly fix each part
		Liquid ref. compression	Adjust the suction gas temp. and pressure	Ensure superheat
		Wear or breakage of the internal comp. parts	Abnormal Sound from the Inside of the Compressor	Replace the compressor
		No heating by the oil heater	Check the Resistance (Oil Heater, Fuse)	Replace the oil heater or the fuse
	Humming sound from the magnetic conductor	Check the surface of the contacts	Replace the magnetic switch	
Abnormal vibration of the cabinets	Check each fixing screw	Tightly fix each screw		
Outdoor fan does not operate when the compressor operates	Obstacle at the outdoor fan	Check the obstacles	Remove the obstacles	
	Watching condition for the heating process	Wait for the switching of the 4-Way Valve (1 ~ 3 minutes)	If the 4-Way Valve does not switch, check for insufficient refrigerant	
Indoor fan does not operate when the compressor operates	Discharge pressure does not increase higher than 1.5 Mpa due to the insufficient refrigerant	Check the operation pressure *5)	Add the refrigerant	
	Disconnected Wiring for the Indoor Fan	Check the wiring	Connect the wiring correctly	



NOTE

- *1): Refer to section [Self-checking of the remote control switch](#).
- *2): Refer to section [Self-checking procedure of PCB by means of the Remote Control Switch](#).
- *3): Even if the remote control switches are normal, the compressor does not operate under the following conditions:
 1. Indoor temp. is lower than 21 °C or outdoor temp. is lower than -5 °C during the cooling process (DB).
 2. Indoor temp. is higher than 27 °C (DB) or outdoor temp. is higher than 15 °C (WB) during the heating process.
 3. When a cooling (or heating) process signal is given to the outdoor unit and a different mode as heating (or cooling) process signal is given to the indoor units.
 4. When an emergency stop signal is given to outdoor unit.
- *4): Refer to chapter [Piping work and refrigerant charge](#).
- *5): Refer to chapter [Test run](#).

8.2 Troubleshooting procedure

8.2.1 Alarm display

On-screen displays during abnormal operation

- Malfunction

The RUN (red) indicator flashes. The ALARM indicator appears on the liquid crystal display. The screen also displays the indoor unit number -A-, the alarm code -B- and the model code -C-. If there are various indoor units connected, the above mentioned information is shown for each one of them -D-. Write down the indications and contact your HITACHI service supplier.

- Power supply failure

All displays disappear. If the unit stops due to a power shortage, it will not start again, even though the power comes back on. Carry out the start-up operations again. If the power failure lasts less than 2 seconds, the unit will start again automatically.

- Electrical noise

The displays can disappear from the screen and the unit can stop. This is because the microcomputer has been activated to protect the unit from electrical noise.



NOTE

If the wireless remote control is used for the wall-type indoor unit, remove the connectors (CN25) that are connected to the indoor PCB. Otherwise the unit will not work. The stored data cannot be erased unless the remote control is initialised.

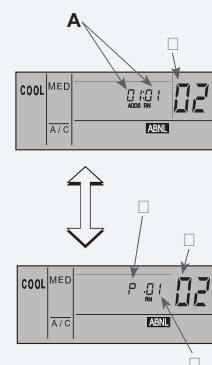

8.2.2 Alarm codes for the outdoor and indoor units

Code No.	Category	Type of Abnormality	Main cause
01	Indoor unit	Activation of protection device (float switch)	Failure of fan motor, drain discharge, PCB, relay, float switch activated.
02	Outdoor unit	Activation of protection device (high pressure cut)	Activation of PSH, locked motor, abnormal operation in the power supply phase.
03	Transmission	Abnormality between indoor (or outdoor) and outdoor (or indoor) units	Incorrect wiring. Loose terminals, Failure of PCB. Tripping of fuse. Power supply OFF.
04		Abnormal operation between inverter and control PCB	Transmission failure between inverter PCBs
05	Power supply	Abnormal power supply	Power source with abnormal wave pattern.
06	Voltage drop	Voltage drop due to excessively low or high voltage in outdoor unit	Voltage drop in power supply. Incorrect wiring or insufficient capacity of power supply wiring.
07	Cycle	Drop in discharge gas overheating	Excessive refrigerant charge. Expansion valve lock open.
08		Increase in discharge gas temperature	Insufficient refrigerant charge, refrigerant leakage. Expansion valve closed or clogged.
11	Sensor in indoor unit	Inlet air thermistor	Failure of thermistor, sensor, connection.
12		Outlet air thermistor	
13		Anti-freeze thermistor	
14		Gas pipe thermistor	
19		Protection device for fan motor is triggered	Failure of fan motor
20	Outdoor unit sensor	Compressor thermistor	Failure of thermistor, sensor, connection.
21		Abnormality of high pressure sensor	
22		Outside air thermistor	
24		Evaporation thermistor	
31	System	Incorrect setting of outdoor and indoor units	Incorrect setting of capacity code.
35		Incorrect setting of indoor unit number	Duplication of indoor unit number.
38		Abnormality of protective circuit in outdoor unit	Failure of indoor unit PCB; incorrect wiring; connection to indoor unit PCB.
41	Pressure	Cooling overload (possible activation of high pressure device)	O.U. pipe thermistor temp. is higher than 55 °C and the compressor top temp. is higher than 95 °C, O.U. protection device is activated.
42		Heating overload (high-pressure device may be activated)	If I.U. freeze protection thermistor temp. is higher than 55 °C and compressor top temp. is higher than 95 °C, O.U. protection device is activated.
45		Activation of high pressure increase protection device	If the discharge pressure (Pd) of the compressor is higher than 3.8MPa for 1 minute.
47		Activation of protection device for low pressure drop	Stoppage due to excessive decrease of evaporating temperature (Temp < -35 °C) is activated 3 times in one hour, motor locked in heating mode.
48	Inverter	Activation of overcurrent protection	Overload, overcurrent. Failure of DIP IPM, IPM or PCB2, heat exchanger clogged, locked compressor.
51		Abnormality in inverter current sensor	Incorrect wiring of current sensor. Failure of control PCB, DIP IPM, IPM or PCB2.
53		Activation of transistor module protection device	Abnormality of DIP IPM or PCB2 Compressor failure, heat exchanger clogged.
54		Abnormality of inverter fin temperature	Abnormal inverter fin thermistor Heat exchanger clogged. Abnormal outdoor fan.
55		Abnormality of inverter module	Failure of DIP-IPM, IPM or PCB2.
57		Outdoor fan	Fan motor abnormality
EE	Compressor	Compressor protection alarm	Compressor failure.
b0	IU Model Setting	Incorrect Setting of Unit Model	No Setting of Unit Model, Incorrect Setting of Unit Model
b1	IU No.Setting	Incorrect unit No. setting	Over 64 indoor units, setting by no. or indoor unit address.
b5		Incorrect Setting of Indoor Unit No. for H-LINK Type	An indoor unit not supporting H-LINK II is set the indoor unit No. as 16 and after.

8.2.3 Troubleshooting by alarm code for the outdoor and indoor units

Alarm code

01

Activation of the safety device in the indoor unit

- The RUN LED flickers and “ALARM” is displayed on the remote control switch.
- The unit number, the alarm code and the unit code are alternately displayed on the set temperature section.
- The unit number and the alarm code are displayed on the display of the outdoor unit PCB.
 - This alarm code is displayed when the contact between #1 and #2 of CN14 is not closed over 120 seconds during the cooling process, the heating process or the fan operation.

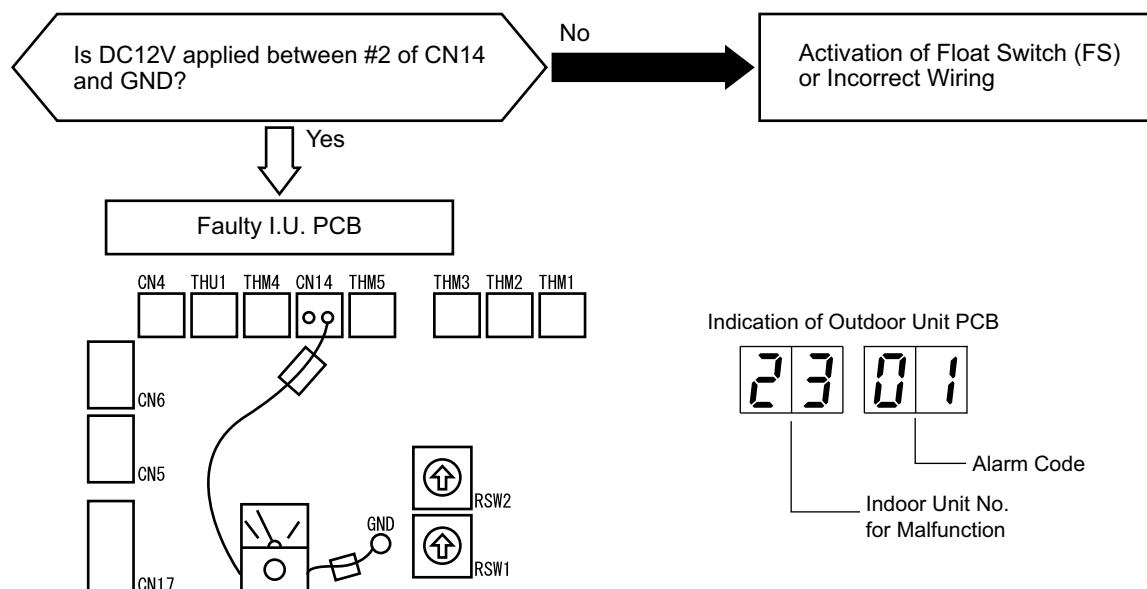

Phenomenon	Cause		Check item	Action (Turn OFF the main switch)
Activation of the float switch	High Drain Level	Clogging of the drainage	Check the drain pan	Remove the clogged foreign particles
	Faulty float switch	Fault	Check the continuity when the drain level is low	Replace the float switch if faulty
		Faulty contacting	Measure the resistance by means of the tester	Fix the looseness and Replace the connector
		Faulty connection	Check the connections	Repair the connection
	Faulty indoor unit PCB		Check PCB by means of the self-check mode *1)	Replace PCB if faulty

NOTE

- *1): Refer to section [Self-checking procedure of PCB by means of the Remote Control Switch](#) in this chapter.
- Alarm code “01” is not displayed at the RPK series.

Alarm code	02	Activation of the safety device (high pressure switch) in the outdoor unit (Except Alarm codes 41 and 42)
------------	----	--

- The RUN LED flickers and “ALARM” is displayed on the remote control switch.
- The unit number, the alarm code and the unit code are alternately displayed on the set temperature section. The unit number and the alarm code are displayed on the display of the outdoor unit PCB.
 - This alarm is indicated when one of safety devices is activated during compressor running.

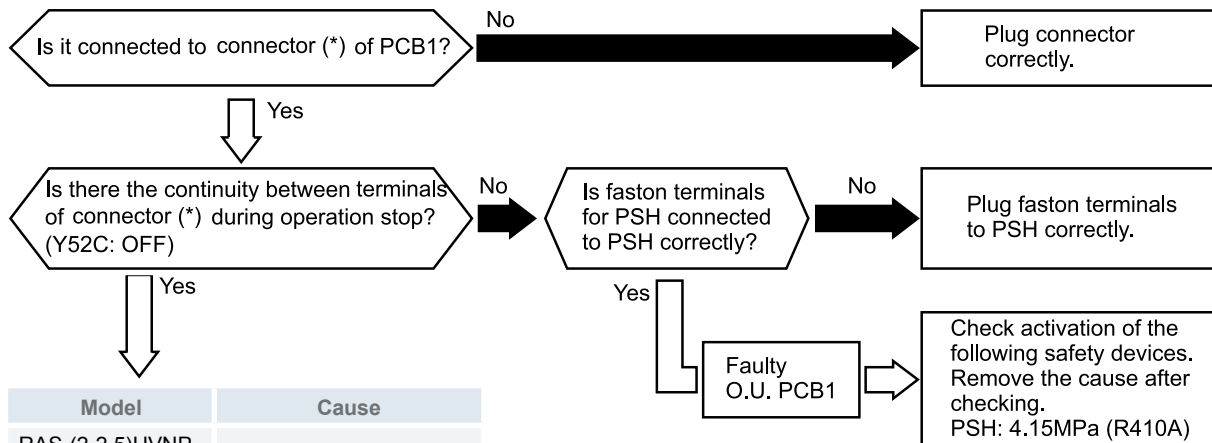

Model	Cause
RAS-(2-2.5)HVNP RAS-3HVNC	Faulty PCB
RAS-(4-6)H(V)NCE	Faulty PCB (IPM)
Other than above	See next diagram

(*)

Model	PCB connector	Pin
RAS-(2-2.5)HVNP RAS-3HVNC	PCN401 (PCB1)	#1-#3
RAS-(4-6)H(V)NCE	CN401 (PCB)	#1-#2
Other than above	PCN8 (PCB1)	#1-#3

RAS-3HVNP / RAS-(4-6)H(V)NPE / RAS-(8-12)HN(P/C)(E)

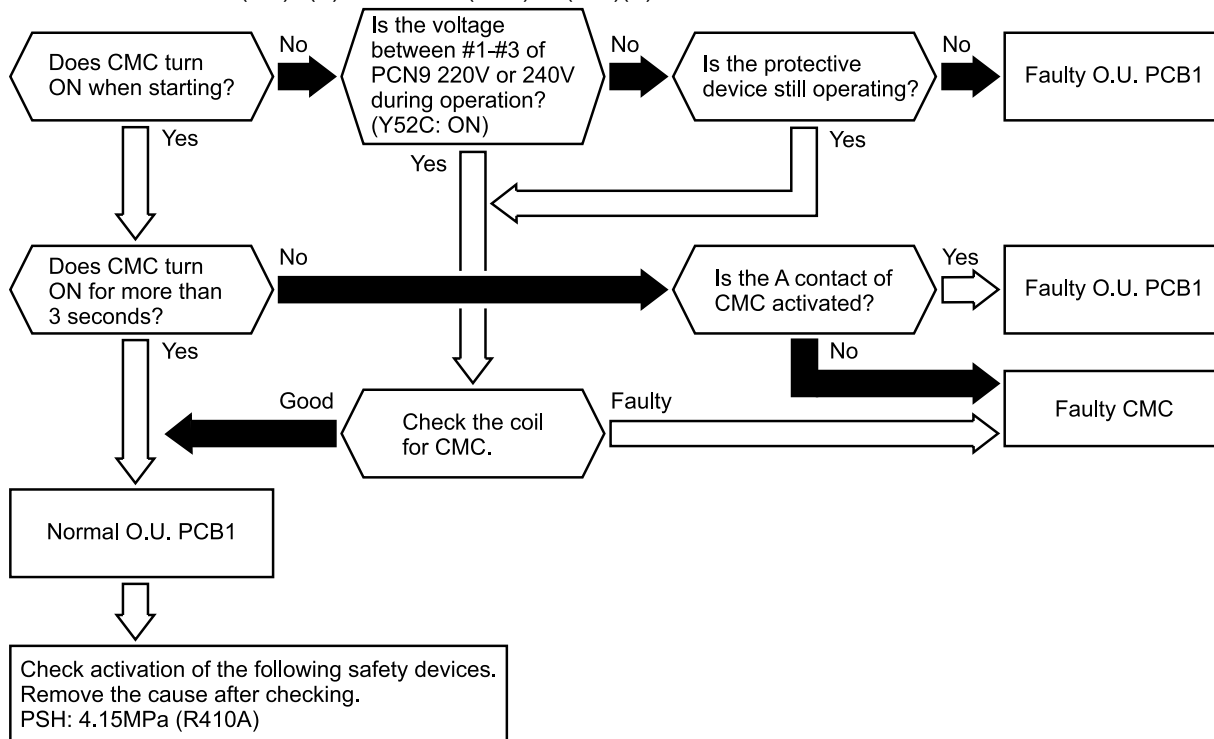

Phenomenon	Cause	Check item	Action (Turn OFF the main switch)	
Activation of the high-pressure switch due to the excessively high discharge pressure	Insufficient Air Flow to the Heat Exchanger (Outdoor Heat Exchanger during the Cooling Process or Indoor Heat Exchanger during the Heating Process)	Check the heat exchanger for dust or for clogging	Remove the dust or the clogging	
		Check the air filter for dust	Remove the dust	
		Check for any obstacles at the inlet or the outlet of the heat exchanger	Remove the obstacles	
		Check the service area	Secure service area	
		Check the speed (Outdoor Fan: Cooling / Indoor Fan: Heating)	Replace the fan motor if faulty	
	Excessively High Temp. Air to the Indoor Unit	Calculate the heat load	Reduce the heat load or use a bigger unit	
		Check for hot air near the ceiling (Heating)	Provide good circulation	
		Check for short-circuited air (Heating)	Remove the short-circuited air	
		Check for other heat source	Remove the heat source	
	Faulty High-Pressure Switch	Faulty Pressure Switch	Measure the discharge pressure. Check the continuity after the decrease of the pressure	Replace the pressure switch if faulty
		Insufficient Contacting	Measure the resistance by means of the tester	Fix the looseness. Replace the connector
		Incorrect Connection	Check the connections	Repair the connections
	Overcharged refrigerant	Check the cycle operation temp.	Charge the refrigerant correctly	
	Mixture of the non-condensate gas in the refrigerant cycle	Check the air temp. and the pressure	Recharge the refrigerant after the vacuum pumping	
Clogging of the discharge piping	Check for clogging	Remove the clogging		
Liquid line stop valve or gas line stop valve is not in operation	Check the stop valves	Fully Open the stop valves		
Faulty Magnet Switch	Incorrect Connection	Check wiring	Repair connections. Replace Magnet Switch	
	Malfunction A Contact	Check connections		

Alarm code

03

Abnormal transmission between the indoor units and the outdoor unit for
RAS-(2-2.5)HVNP / RAS-3HVNC

- The RUN LED flickers and “ALARM” is displayed on the remote control switch.
- The unit number, the alarm code and the unit code are alternately displayed on the set temperature section.
- The unit number and the alarm code are displayed on the display of the outdoor unit PCB.
 - This alarm is displayed when an abnormal operation is maintained for three minutes after the normal transmission between the indoor units and the outdoor unit. Also, an abnormal operation is maintained for 30 seconds after the micro-computer is automatically reset.
 - The alarm is displayed when the abnormal transmission is maintained for 30 seconds from the starting of the outdoor unit.
 - Investigate the cause of the overcurrent and take the necessary action when the fuses are blown out or the breaker for the outdoor unit is activated.

O.U.: Outdoor Unit
I.U.: Indoor Unit

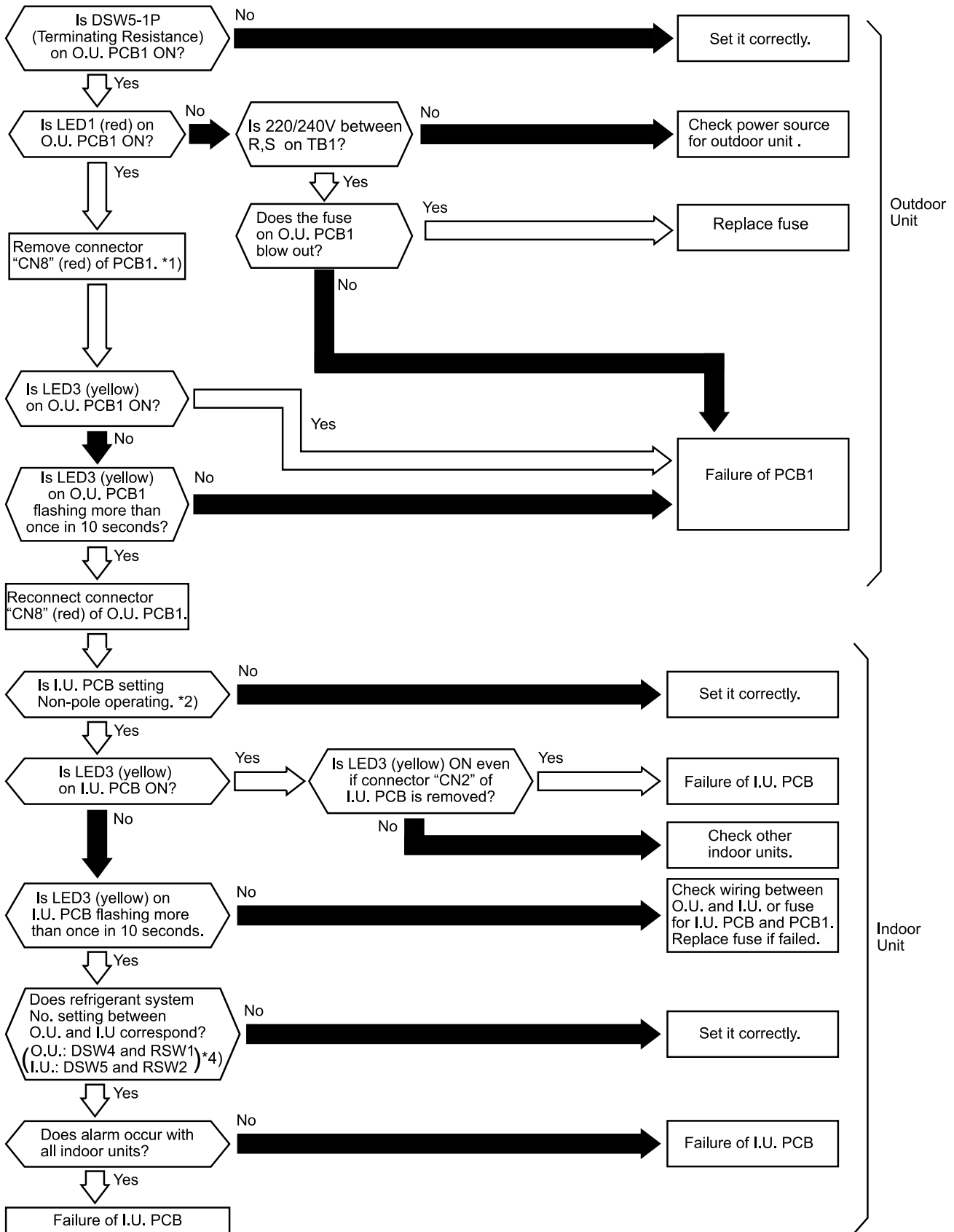

Phenomenon	Cause	Check item	Action (Turn OFF the main switch)
Power failure or power is not ON		Measure the voltage by means of the tester	Supply the power
Blown out fuse for the power source or activation of the outdoor unit breaker	Short-circuit between the wires	Check the insulation material for breaks	Remove the short-circuit and replace the fuse
	Short-circuited wire to ground	Measure the insulation resistance	Remove short-circuit to ground and replace the fuse
	Faulty comp. motor	Measure the resistance between the wires and the insulation resistance	Replace the comp. and the fuse
	Failure of outdoor unit fan motor	Measure resistance between wires and insulation resistance	Replace the unit fan motor and the fuse
Blown out fuse for control circuit or activation of outdoor unit breaker	Short-circuit between the wires	Check the insulation material for breaks	Remove the short-circuit and replace the fuse
	Short-circuit of the control circuit (to ground)	Measure the insulation resistance	Remove the short-circuit and replace the fuse
	Faulty solenoid coil for the magnetic switch for the comp. motor	Measure the resistance of coil	Replace the magnetic switch and the fuse
	Failure of outdoor unit fan motor	Measure the resistance between the wires and the insulation resistance	Replace the outdoor unit fan motor and fuse
PCB1 Power circuit failure		PCB1 Measure output voltage *1)	Replace PCB1
Disconnected wires insufficient contacting or incorrect connection	Between outdoor unit and indoor unit	Check the continuity of the wires	Replacing wires repairing and tightening the Power source wiring for the screws and the correct wiring
	Power source wiring for the screws and the correct wiring outdoor unit	Check for looseness of the connection screws Check the terminal Nos.	
Faulty PCB (outdoor unit, indoor unit)	Disconnected wires to PCB	Check the connections	Correctly connect the wires
	Faulty PCB	—	Replace PCB if faulty
Incorrect wiring	Disconnected wire; insufficient contacting	Check the continuity and the looseness of connection screws	Replacing wires, repairing and tightening the screws
	Incorrect wiring	Check the terminal Nos.	Correctly connect the wires

 **NOTE**

- *1) In the case that the end terminal resistance (DSW5-1) is set to OFF for H-LINK connection, set the end terminal resistance to ON when CN8 is disconnected. Set the end terminal resistance to OFF when CN8 is reconnected.
- *2) Transmission Setting (SW1)

Item	Setting Position
SW1	Left Side (for H-LINK/H-LINK II)

- *3)

PCB1 output voltage	Voltage
Vcc 12 – GND2	12 VDC
Vcc 05 – GND1	5 VDC
Vcc 12 – GND1	12 VDC
Vcc 15 – GND1	15 VDC
Vcc 24 – GND1	24 VDC
Vcc 12T – GND1	12 VDC

- *4) The rotary switch (RSW2) is not available depending on the indoor unit model.

Alarm code

03

Abnormal transmission between the indoor units and the outdoor unit for
RAS-(3-12)H(V)N(P/C)(E)

- The RUN LED flickers and “ALARM” is displayed on the remote control switch.
- The unit number, the alarm code and the unit code are alternately displayed on the set temperature section.
- The unit number and the alarm code are displayed on the display of the outdoor unit PCB.
 - This alarm is displayed when an abnormal operation is maintained for three minutes after the normal transmission between the indoor units and the outdoor unit. Also, an abnormal operation is maintained for 30 seconds after the micro-computer is automatically reset.
 - The alarm is displayed when the abnormal transmission is maintained for 30 seconds from the starting of the outdoor unit.
 - Investigate the cause of the overcurrent and take the necessary action when the fuses are blown out or the breaker for the outdoor unit is activated.

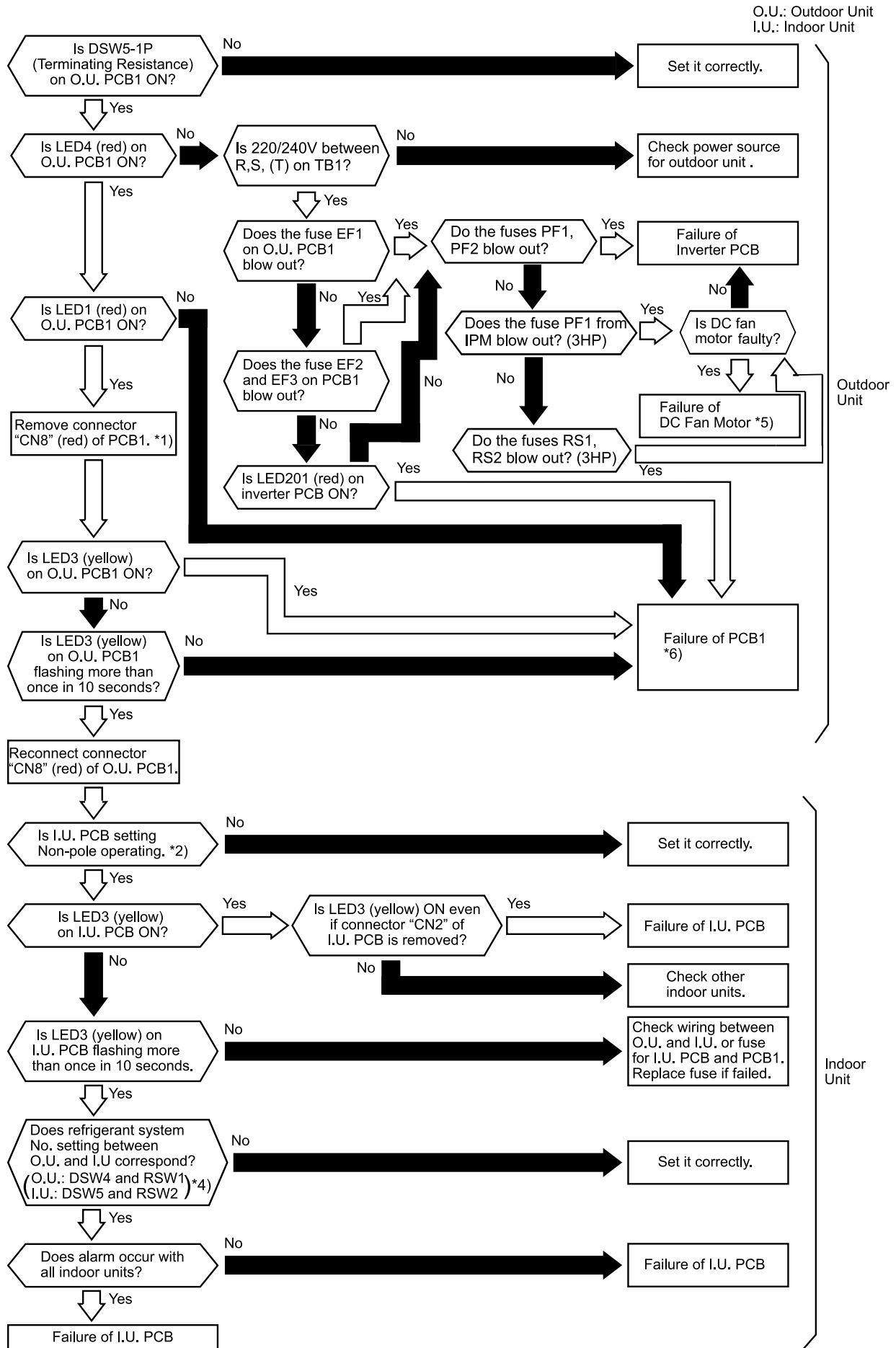

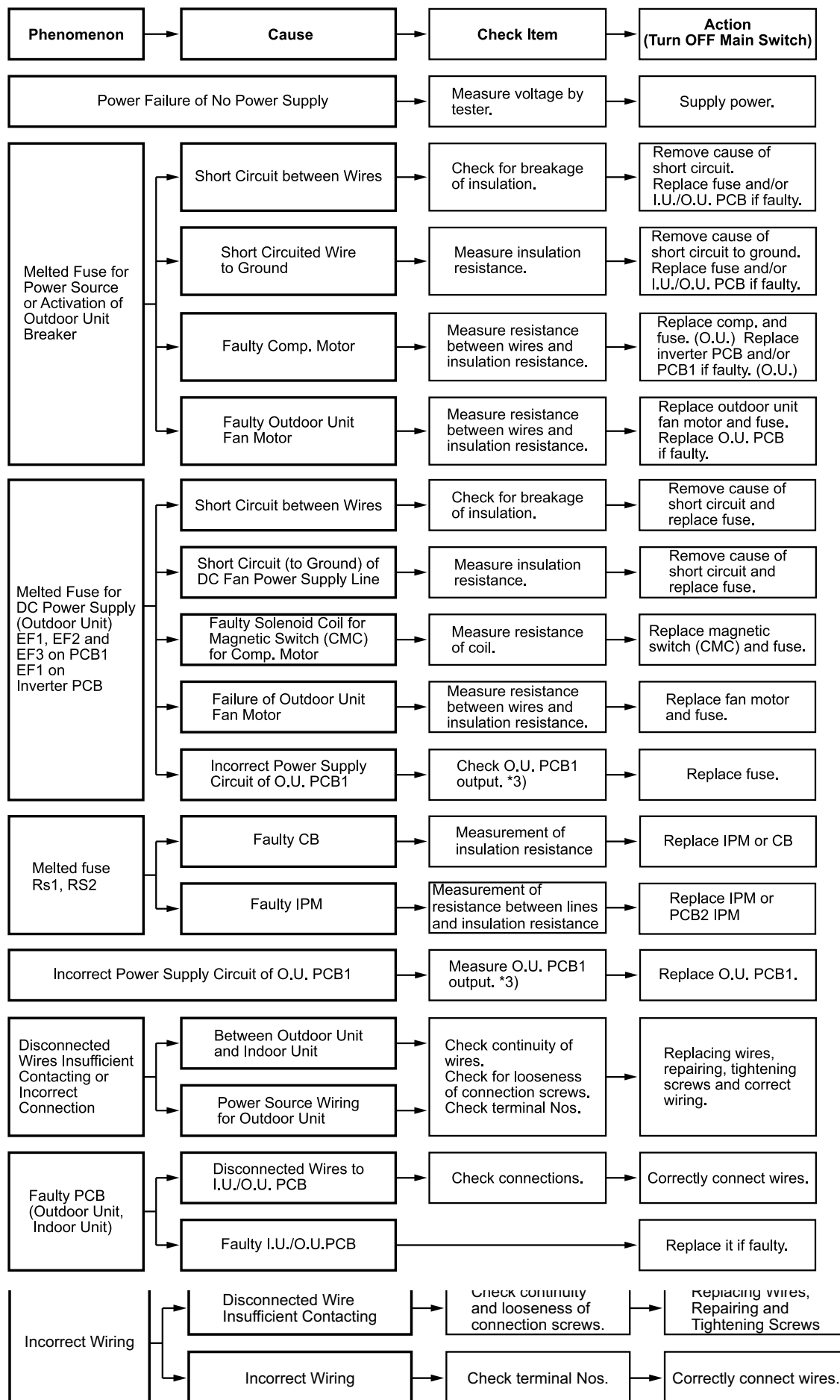

**NOTE**

- ***1) In the case that the end terminal resistance (DSW5-1) is set to OFF for H-LINK connection, set the end terminal resistance to ON when CN8 is disconnected. Set the end terminal resistance to OFF when CN8 is reconnected.**
- ***2) Transmission Setting (SW1)**

Item	Setting Position
SW1	Left Side (for H-LINK/H-LINK II)

- ***3)**

PCB1 output voltage	Voltage
Vcc 12 – GND2	12 VDC
Vcc 05 – GND1	5 VDC
Vcc 12 – GND1	12 VDC
Vcc 15 – GND1	15 VDC
Vcc 24 – GND1	24 VDC
Vcc 12T – GND1	12 VDC

- ***4) The rotary switch (RSW2) is not available depending on the indoor unit model.**
- ***5) Surely perform the troubleshooting of DC fan motor. If DC fan motor fails, the normal inverter PCB may be damaged.**
- ***6) Refer to section [Checking procedure of PCB by means of the Remote Control Switch](#).**

Alarm code

04

Abnormal transmission between Inverter PCB and Outdoor PCB1

- The RUN LED flickers and “ALARM” is displayed on the remote control switch.
- The unit number, the alarm code and the unit code are alternately displayed on the set temperature section. The unit number and the alarm code are displayed on the display of the outdoor unit PCB.
 - This alarm is displayed when the abnormal operation is maintained for 30 seconds after the normal transmission between the outdoor unit PCB1 and inverter PCB2. Also, the abnormal operation is maintained for 30 seconds after the micro-computer is automatically reset. The alarm is displayed when the abnormal transmission is maintained for 30 seconds from the starting of the outdoor unit.

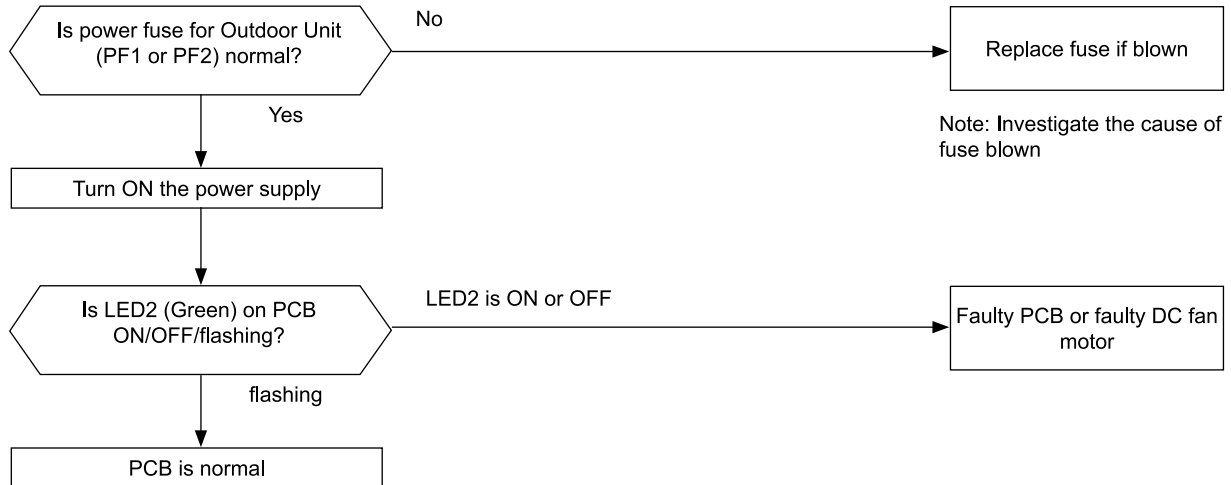
RAS-(2-2.5)HVNP / RAS-3HVNC / RAS-(4-6)H(V)NCE

RAS-(3-6)H(V)NPE

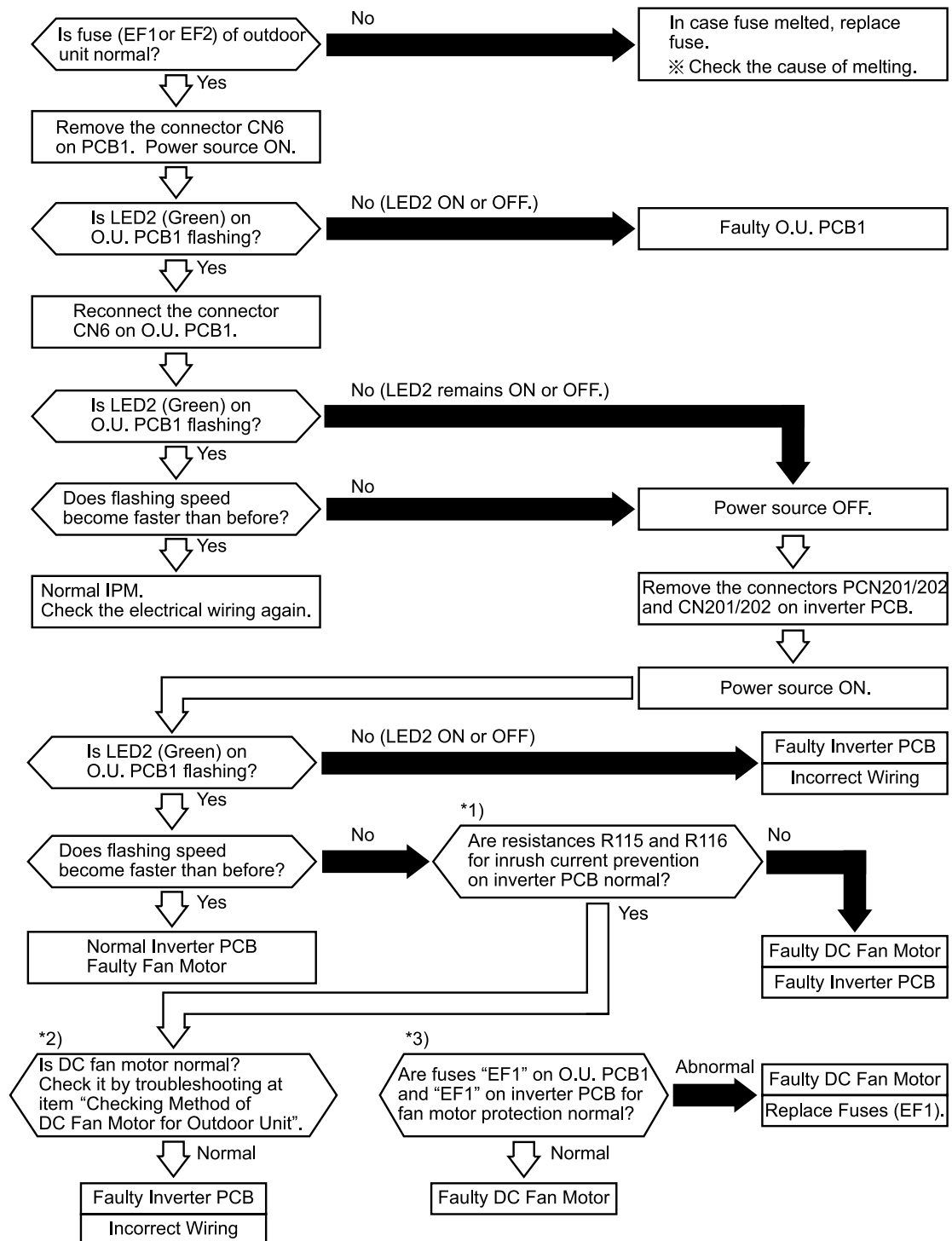

8



NOTE

- *1): Surely perform the troubleshooting of the resistance for inrush current prevention (R115/R116) on inverter PCB. If the resistance for inrush current prevention (R115/R116) fails, the abnormal transmitting occurs.
- *2): Surely perform the troubleshooting of DC fan motor according to section [Procedure of checking other main parts](#). If the DC fan motor fails, the normal inverter PCB may be damaged.
- *3): Perform the troubleshooting of the fuses "EF1" on O.U. PCB1 and "EF1" on inverter PCB for fan motor protection. If the fuses for fan motor protection fail, DC fan motor is not operated normally.

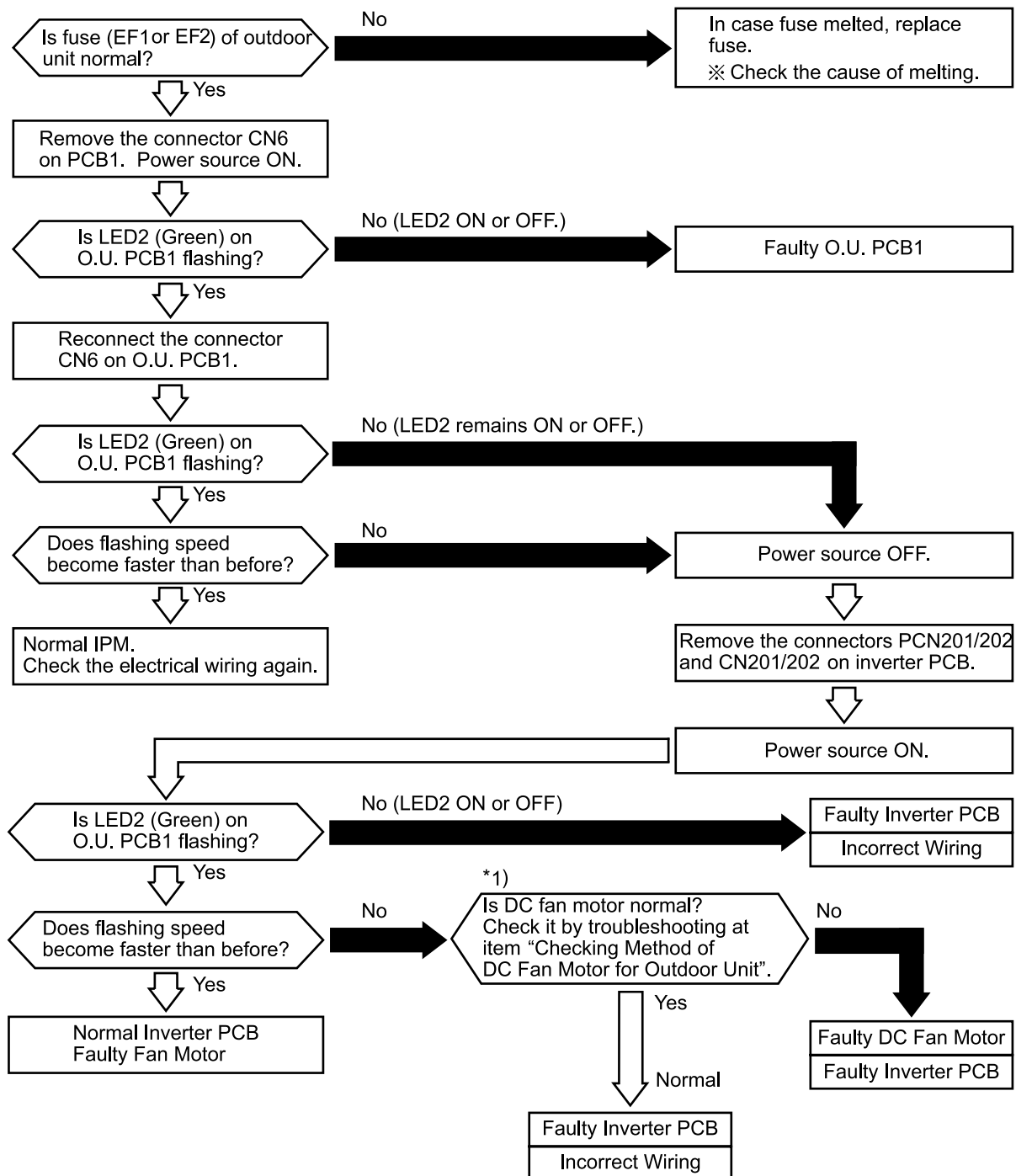
RAS-(8-12)HN(P/C)(E)**NOTE**

Surely perform the troubleshooting of DC fan motor according to section [Procedure of checking other main parts](#).
If the DC fan motor fails, the normal inverter PCB may be damaged.

Alarm code

05

Code abnormal operation of picking up phase signal

- The RUN LED flickers and “ALARM” is displayed on the remote control switch.
- The unit number, the alarm code and the unit code are alternately displayed on the set temperature section. The unit number and the alarm code are displayed on the display of the outdoor unit PCB.
 - This alarm is displayed when the main power source phase is reversely connected or one phase is not connected.

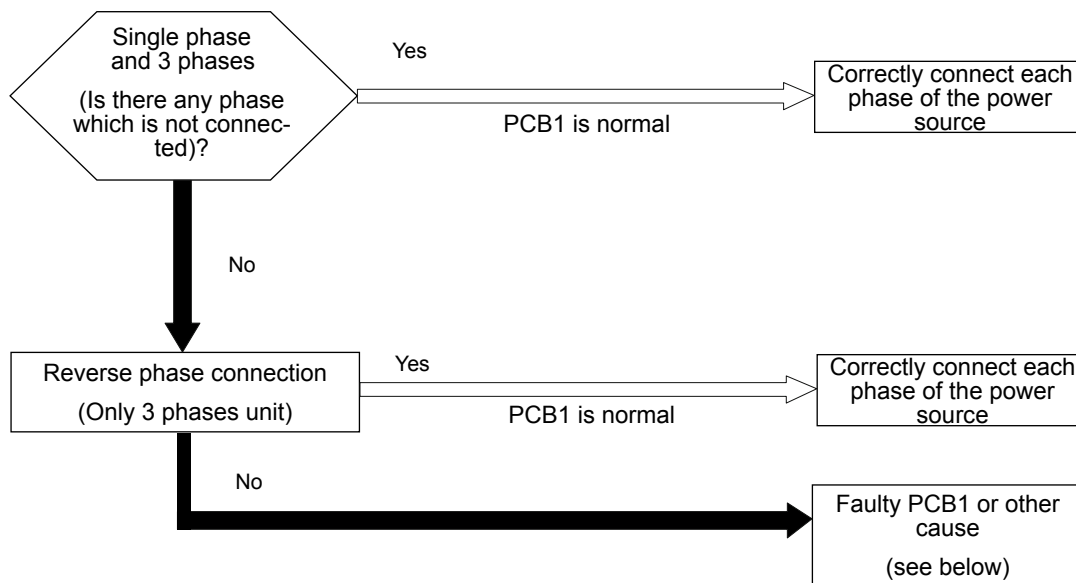

RAS-(2-6)HVN(P/C)(E)

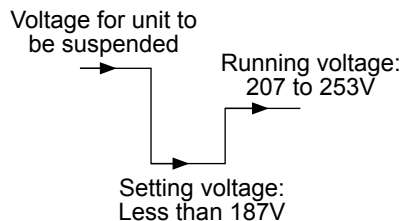

RAS-(4-12)HN(P/C)(E)

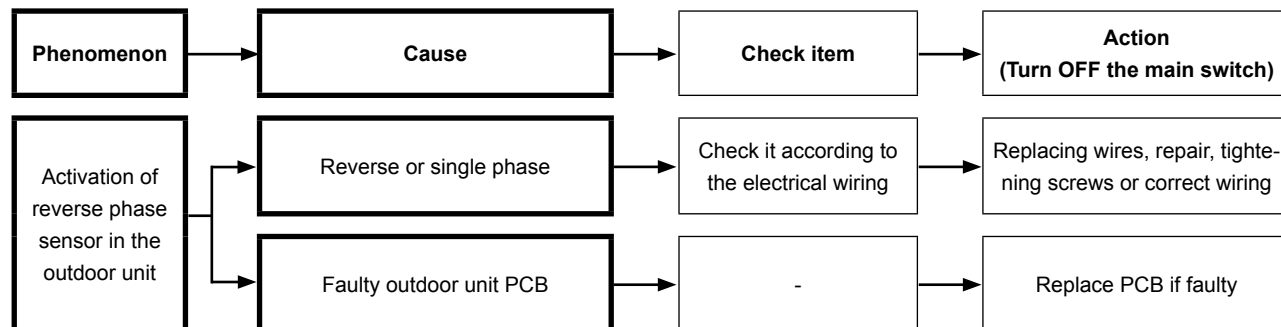
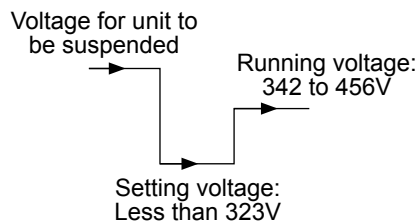

Alarm code

06

Excessively low voltage or excessively high voltage for the inverter

- The RUN LED flickers and “ALARM” is displayed on the remote control switch.
- The unit number, the alarm code and the unit code are alternately displayed on the set temperature section.
- The unit number and the alarm code are displayed on the display of the outdoor unit PCB.
 - This alarm code is displayed when the voltage between terminal “P” and “N” of Inverter is insufficient and the alarm has three occurrences in 30 minutes. If the number of occurrences is smaller than two, the retry operation is performed. The alarm code “06.” Means fan controller Abnormal Operation.

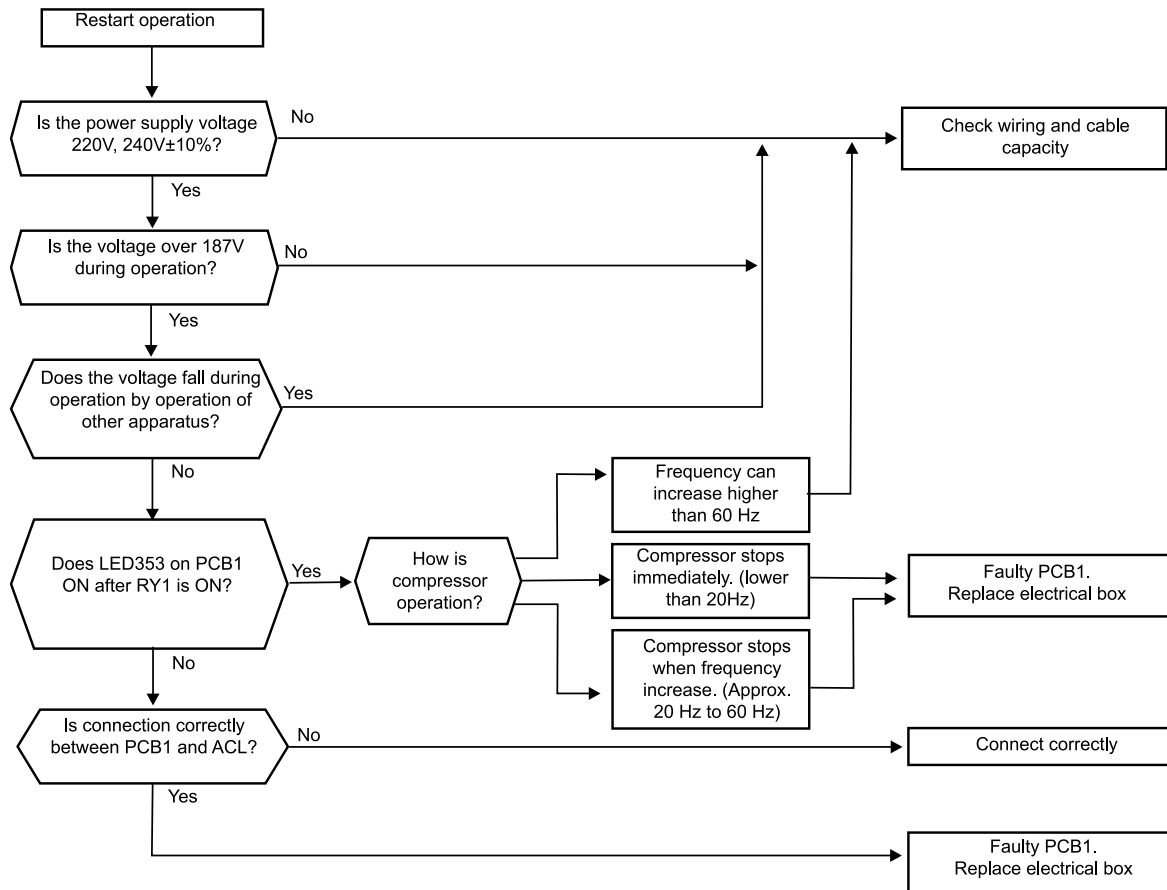
RAS-(2-2.5)HVNP / RAS-3HVNC**NOTE**

Replace electrical box only when LED is OFF.

RAS-(3-6)H(V)NPE / RAS-(8-12)HN(P/C)(E)

PCB1: Control PCB in Outdoor unit
PCB2: Inverter PCB in Outdoor unit

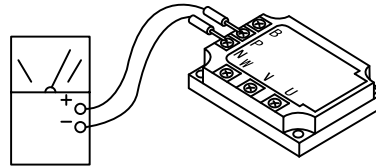

Direct current
Measuring position

Measuring Range: DC1000V

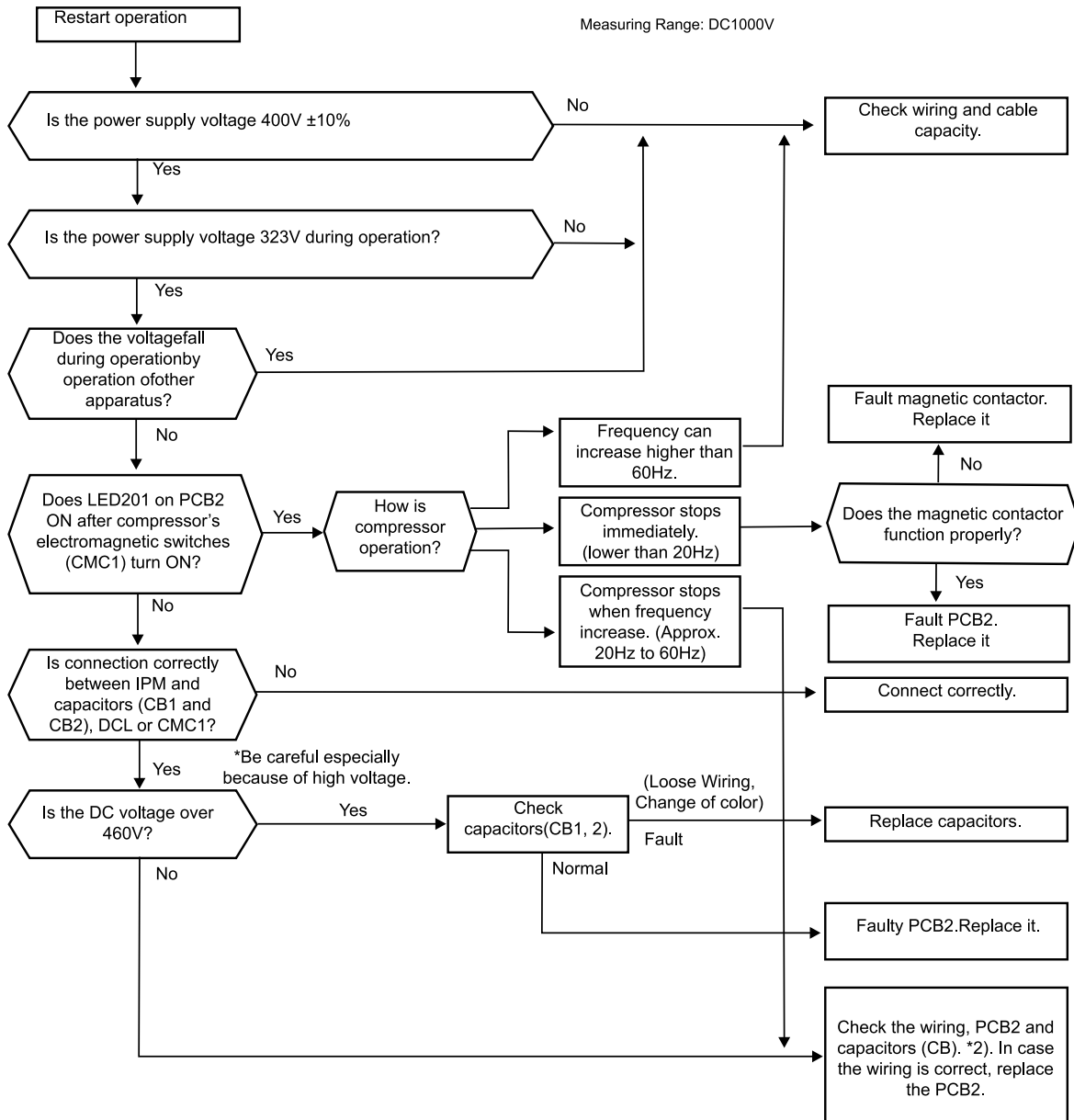

NOTE

- **The indicated voltage is for three phase models. The power supply voltage for single phase models is 220V and 187V during operation.**
- ***1): If capacitor has high voltage, perform the high voltage discharge work refer to the item [Procedure of checking other main parts](#).**
- ***2): Regarding replacing or checking method for the inverter PCB, refer to the item [Procedure of checking other main parts](#).**

Alarm code

07

Decrease of Discharge Gas Superheat

- The RUN LED flickers and “ALARM” is displayed on the remote control switch.
- The unit number, the alarm code and the unit code are alternately displayed on the set temperature section. The unit number and the alarm code are displayed on the display of the outdoor unit PCB.
- This alarm code is indicated as follows:
 - When the temperature at the top of the compressor is lower than condensing temperature and indoor expansion valve opening is lower than 300 pulse for 30 minutes in cooling operation, retry operation will be performed once. When outdoor expansion valve opening is lower than 70 pulse for 30 minutes in heating operation, retry operation will be performed once. If these occurs again within 120 minutes after the retry, the alarm code will be indicated.

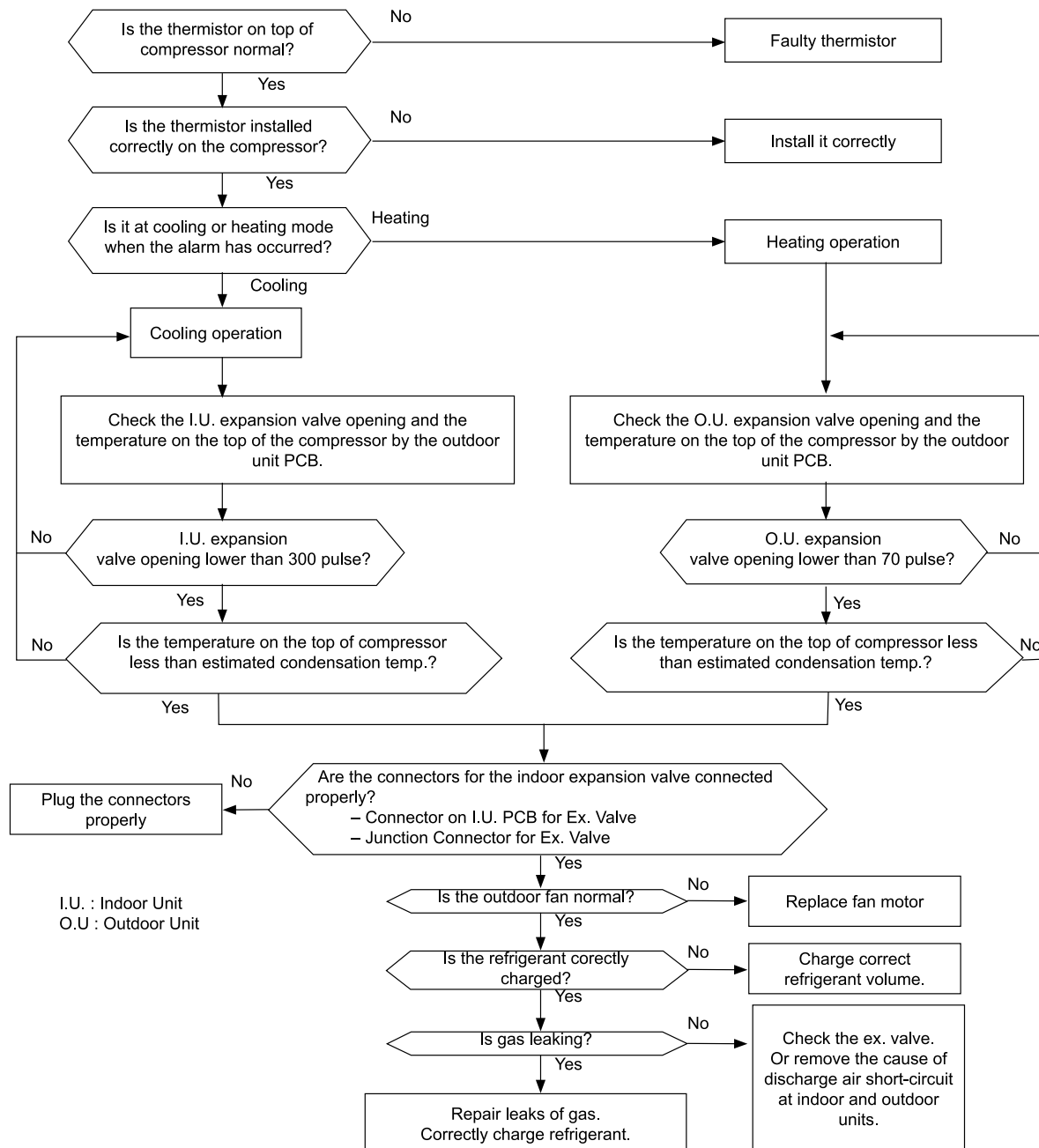

Phenomenon	Cause		Check item	Action (Turn OFF the main switch)
Decrease of Discharge Gas Superheat	Ref. cycle is different from the electrical system		Check ref. cycle and the electrical system	Repair wiring
	Overcharged Refrigerant		Measure pressure	Correctly charge refrigerant
	Faulty Expansion Valve		Check expansion valve *1)	Replace expansion valve if faulty
	Faulty PCB	Fault	Replace PCB and check operation	Replace PCB if faulty
		Disconnected Wires for Ex.Valve Control	Check connections.	Repair wiring connections
	Faulty Discharge Gas Thermistor	Fault	Measure resistance.	Replace thermistor if faulty
		Incorrect Mounting	Check mounting state (See "Alarm Code 08".)	Correctly mount thermistor.
		Incorrect Connection	Check connections.	Remove looseness, replace connector or repair connections.

**NOTE**

- *1) Refer to section *Procedure of checking other main parts*, in part "Checking procedure for the electronic expansion valve".

Alarm code

08

Excessively High Discharge Gas Temperature at the Top of Compressor

- The RUN LED flickers and “ALARM” is displayed on the remote control switch.
- The unit number, the alarm code and the unit code are alternately displayed on the set temperature section. The unit number and the alarm code are displayed on the display of the outdoor unit PCB.
 - The alarm appears during cooling operation when the compressor-top thermistor remains at Tdc 1 °C or above for 10 minutes, or at Tdc 2 °C or above for 5 seconds.
 - The alarm appears during heating operation when the compressor-top thermistor remains at Tdh 1 °C or above for 10 minutes, or at Tdh 2 °C or above for 5 seconds.

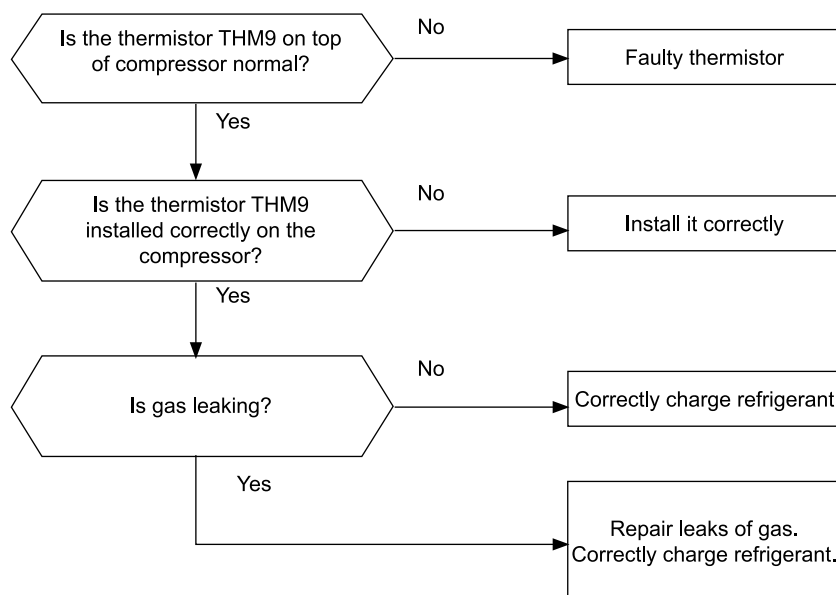

Compressor-top thermistor (THM9)

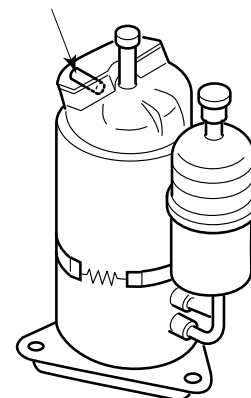

Compressor-top thermistor (THM9)

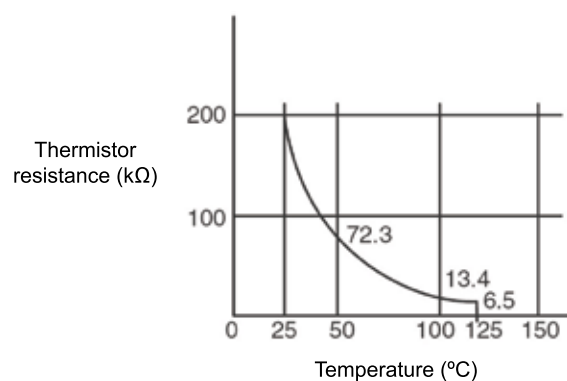
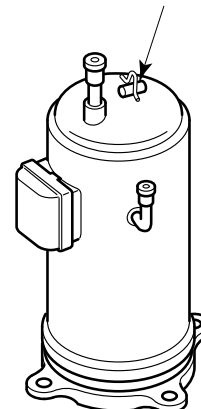

Thermistor resistance characteristics

Outdoor capacity	Tdc1	Tdc2	Tdh1	Tdh2
RAS-(2-6)H(V)N(P/C)(E)	115	125	115	125
RAS-(8-12)HNP(E)	127	135	120	135
RAS-(8-12)HNC(E)	127	140	120	140

Alarm code



Abnormal operation of thermistor for the indoor unit air inlet temperature (air inlet thermistor)

- The RUN LED flickers and “ALARM” is displayed on the remote control switch.
- The unit number, the alarm code and the unit code are alternately displayed on the set temperature section. The unit number and the alarm code are displayed on the display of the outdoor unit PCB.
- This alarm code is displayed when the thermistor is short-circuited (less than 0.24 kΩ) or cut (greater than 840 kΩ) during the cooling process or the heating process. The system is automatically restarted when the fault is removed.

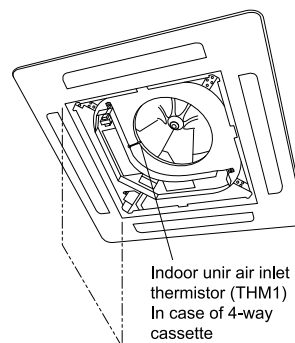
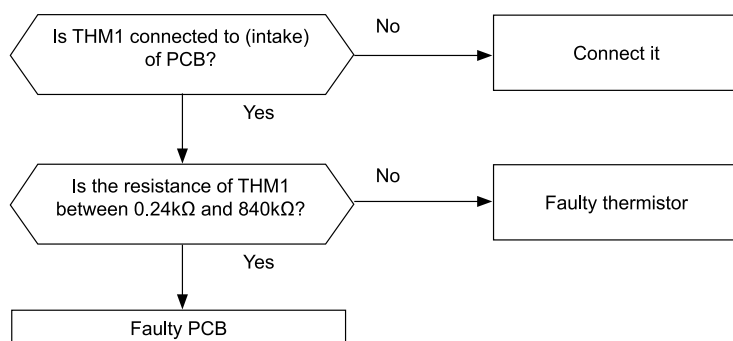

Phenomenon	Cause	Check item	Action (Turn OFF the main switch)
Faulty air inlet thermistor	Fault	Check the resistance	Replace the thermistor if faulty
	Incorrect connection	Check the connection	Repair the wiring and the connections
Faulty PCB		Replace PCB and check the operation	Replace PCB if faulty

**NOTE**

- **This data is applicable to the following thermistors:**
 - Indoor unit discharge air temperature
 - Indoor unit liquid refrigerant temperature
 - Indoor unit air inlet temperature
 - Outdoor temperature
 - Outdoor unit evaporating temperature
 - Indoor unit gas piping

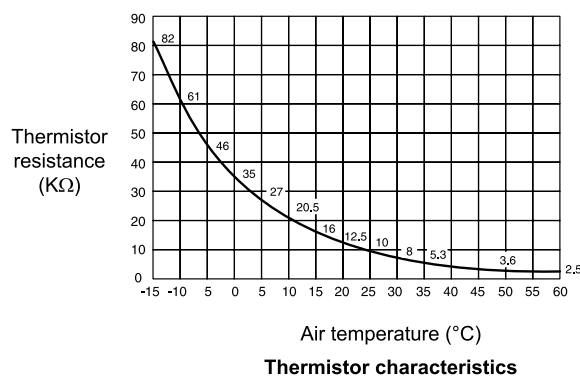

Alarm code

12

Abnormal operation of the thermistor for the indoor discharge air temperature (air outlet thermistor)

- The RUN LED flickers and “ALARM” is displayed on the remote control switch.
- The unit number, the alarm code and the unit code are alternately displayed on the set temperature section. The unit number and the alarm code are displayed on the display of the outdoor unit PCB.
- This alarm code is displayed when the thermistor is short-circuited (less than 0.24 k Ω) or cut (greater than 840 k Ω) during the cooling process or the heating process. The system is automatically restarted when the fault is removed.

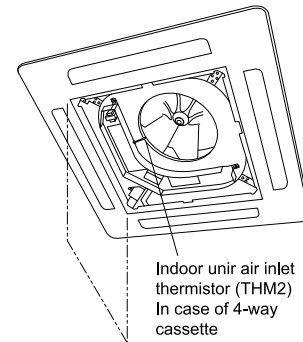
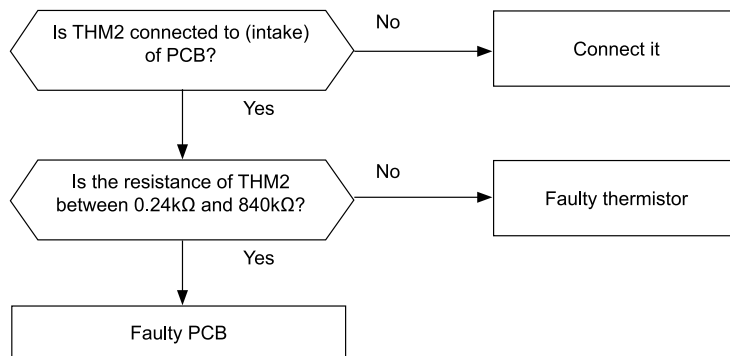

Phenomenon	Cause	Check item	Action (Turn OFF the main switch)
Faulty air outlet thermistor	Fault	Check the resistance	Replace the thermistor if faulty
	Incorrect connection	Check the connection	Repair the wiring and connections
Faulty PCB		Replace PCB and check the operation	Replace PCB if faulty

Alarm code

13

Abnormal operation of the thermistor for the indoor unit heat exchanger liquid pipe temperature (freeze protection thermistor)

- The RUN LED flickers and “ALARM” is displayed on the remote control switch.
- The unit number, the alarm code and the unit code are alternately displayed on the set temperature section. The unit number and the alarm code are displayed on the display of the outdoor unit PCB.
 - This alarm code is displayed when the thermistor is short-circuited (less than 0.24 kΩ) or cut (greater than 840 kΩ) during the cooling process or the heating process. The system is automatically restarted when the fault is removed.

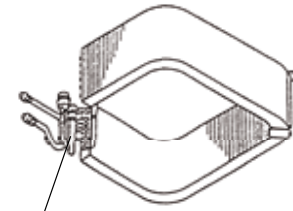
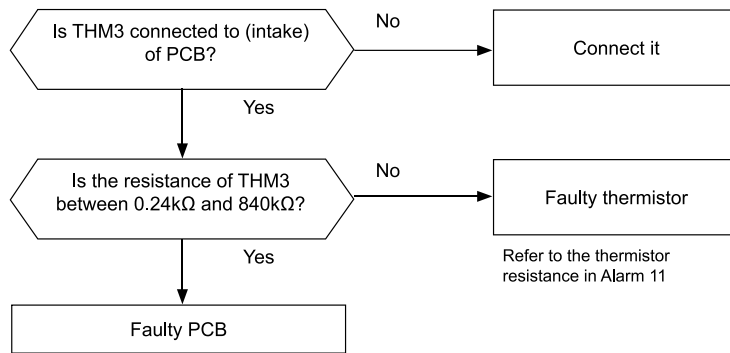

Freeze protection thermistor (THM3)
In case of 4-way cassette

Phenomenon	Cause	Check item	Action (Turn OFF the main switch)
Faulty freeze protection thermistor	Fault	Check the resistance	Replace the thermistor if faulty
	Incorrect connection	Check the connection	Repair the wiring and connections
Faulty PCB		Replace PCB and check the operation	Replace PCB if faulty

Alarm code

14

Abnormal operation of the thermistor for the indoor unit heat exchanger gas pipe temperature (gas piping thermistor)

- The RUN LED flickers and “ALARM” is displayed on the remote control switch.
- The unit number, the alarm code and the unit code are alternately displayed on the set temperature section. The unit number and the alarm code are displayed on the display of the outdoor unit PCB.
- This alarm code is displayed when the thermistor is short-circuited (less than 0.24 kΩ) or cut (greater than 840 kΩ) during the cooling process or the heating process. The system is automatically restarted when the fault is removed.

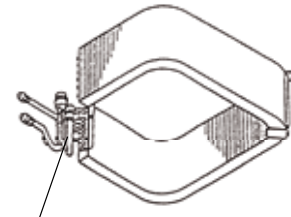
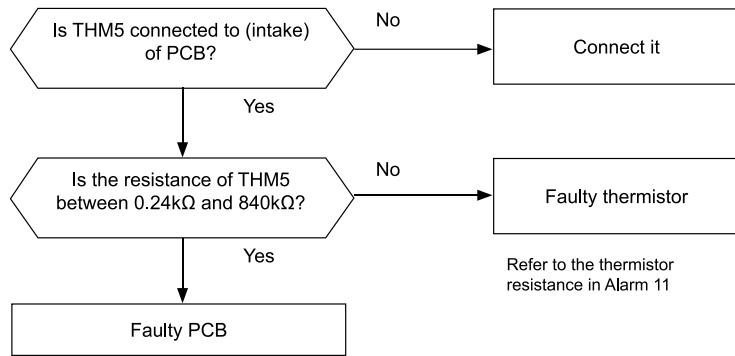

Heat exchanger gas pipe thermistor (THM3)
In case of 4-way cassette

Phenomenon	Cause	Check item	Action (Turn OFF the main switch)
Faulty gas piping thermistor	Fault	Check the resistance	Replace the thermistor if faulty
	Incorrect connection	Check the connection	Repair the wiring and connections
Faulty PCB		Replace PCB and check the operation	Replace PCB if faulty

Alarm code

19

Activation of the protection device for the indoor fan motor (except RCI, RCIM and RPK)

- The RUN LED flickers and “ALARM” is displayed on the remote control switch.
- The unit number, the alarm code and the unit code are alternately displayed on the set temperature section. The unit number and the alarm code are displayed on the display of the outdoor unit PCB.
- This alarm code is displayed when the temperature of the internal thermostat for the indoor fan motor is higher than 135 °C.

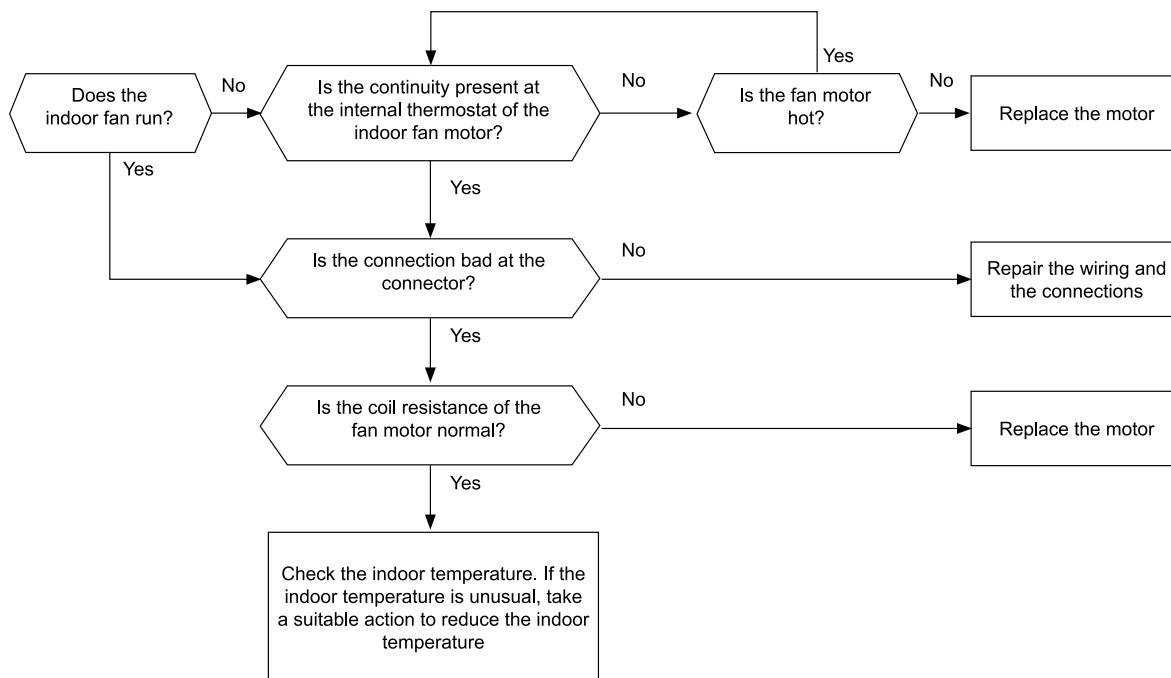

Phenomenon	Cause	Check item	Action (Turn OFF the main switch)	
Activation of the internal thermostat for the indoor unit fan motor	Faulty indoor unit fan motor	Measure the coil resistance and the insulation resistance	Replace the motor if faulty	
	Faulty internal thermostat	Fault	Check the continuity after the fan motor temperature decreases to room temp	Replace the fan motor if there is no continuity
		Insufficient contacting	Measure the resistance by means of the tester	Correct looseness. Replace the connectors
		Incorrect connection	Check the connections	Repair the connections

8

Alarm code

19

Activation of the protection device for the indoor fan motor (RCI, RCIM)

- The RUN LED flickers and “ALARM” is displayed on the remote control switch.
- The unit number, the alarm code and the unit code are alternately displayed on the set temperature section.
- The unit number and the alarm code are displayed on the display of the outdoor unit PCB1.
 - This alarm code is displayed when the following conditions occurs three times in 30 minutes. Indoor fan rotates less than 70 rpm for 5 seconds during operation.
- When the cause is checked by means of this flow chart, confirm that fan speed setting is Hi

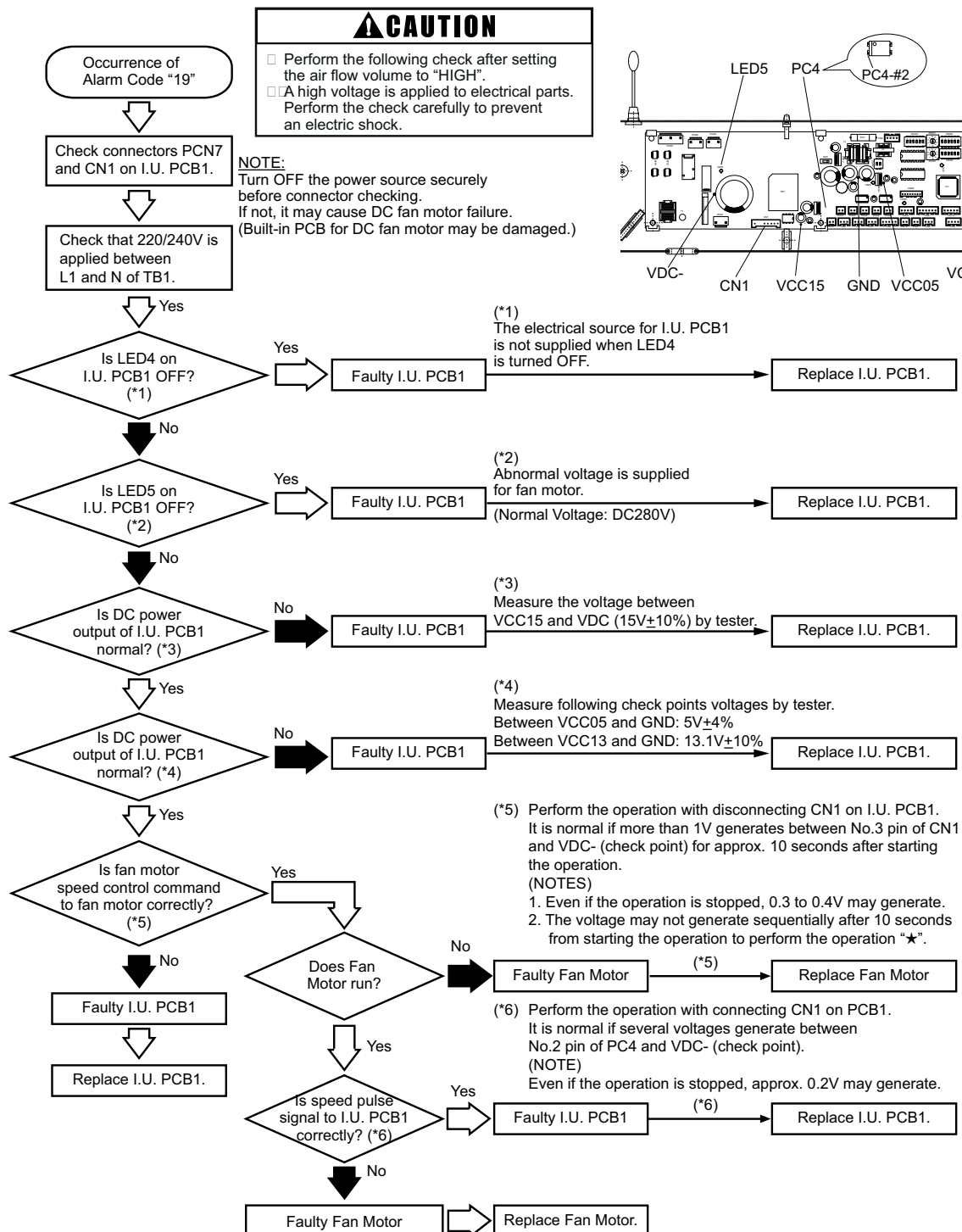

Alarm code

19

Activation of the protection device for the indoor fan motor (RPK)

- The RUN LED flickers and “ALARM” is displayed on the remote control switch.
- The unit number, the alarm code and the unit code are alternately displayed on the set temperature section. The unit number and the alarm code are displayed on the display of the outdoor unit PCB1.
- This alarm code is displayed when the following conditions occurs three times in 30 minutes. Indoor fan rotates less than 70 rpm for 5 seconds during operation.
- Set air flow volume “Hi” before starting this check.

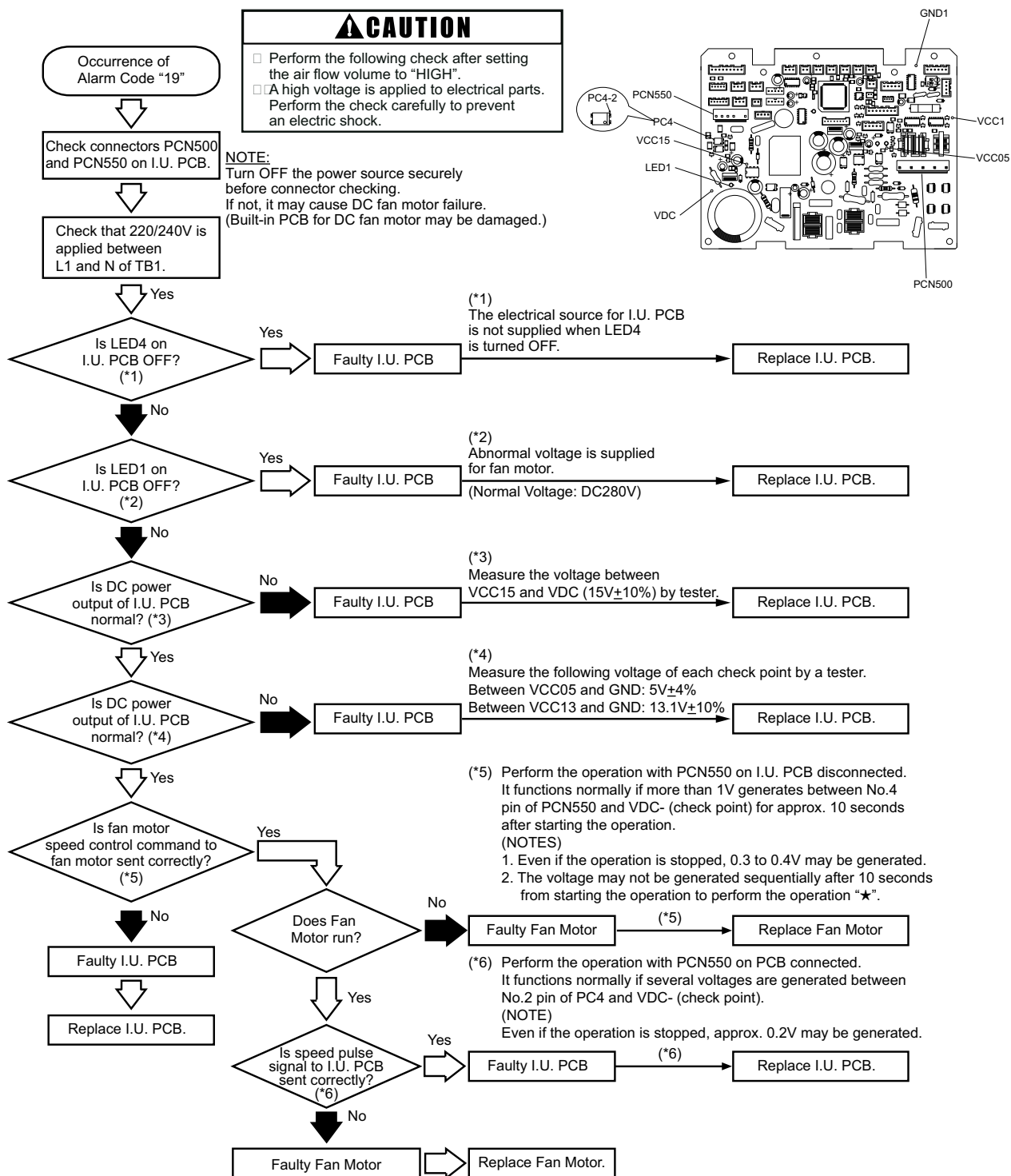

8

Alarm code **20** Abnormality of Thermistor for Discharge Gas Temperature (Compressor Thermistor)

- The RUN LED flickers and “ALARM” is displayed on the remote control switch.
- The unit number, the alarm code and the unit code are alternately displayed on the set temperature section. The unit number and the alarm code are displayed on the display of the outdoor unit PCB.
 - This alarm code is indicated when the thermistor is short-circuited (less than 1 kΩ) or cut (greater than 6 MΩ) during the cooling or heating operation.

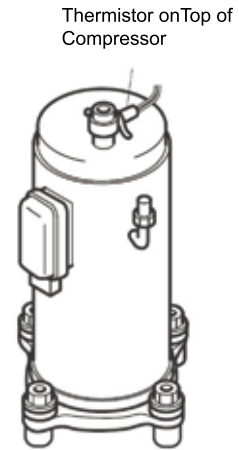
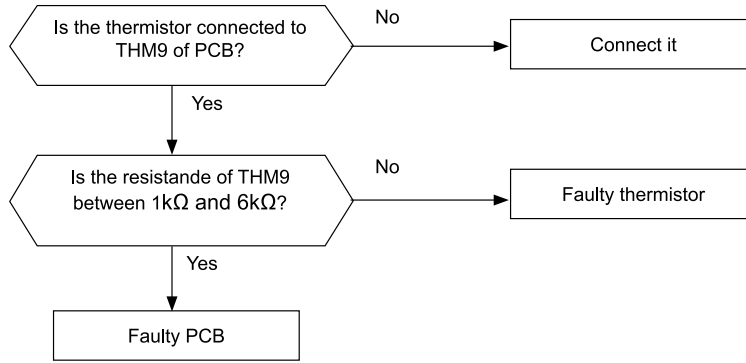

Phenomenon	Cause	Check item	Action (Turn OFF Main Switch)
Faulty top of compressor thermistor	Fault	Check resistance	Replace thermistor if faulty
	Incorrect connection	Check wiring to PCB1	Repair wiring and connections
Faulty PCB1		Replace PCB1 and check operation	Replace PCB1 if faulty

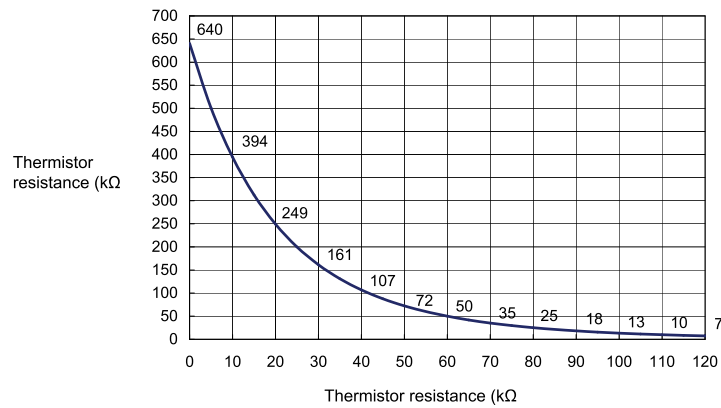

The resistance value have fudge factor (+10%).

Alarm code

21

Abnormality of High pressure sensor for RAS-(3-12)H(V)NP(E)

- The RUN LED flickers and “ALARM” is displayed on the remote control switch.
- The unit number, the alarm code and the unit code are alternately displayed on the set temperature section. The unit number and the alarm code are displayed on the display of the outdoor unit PCB.
 - This alarm code is indicated when the pressure sensor output voltage decreases (less than 0.1V) or increases (more than 4.9V) during the operation.

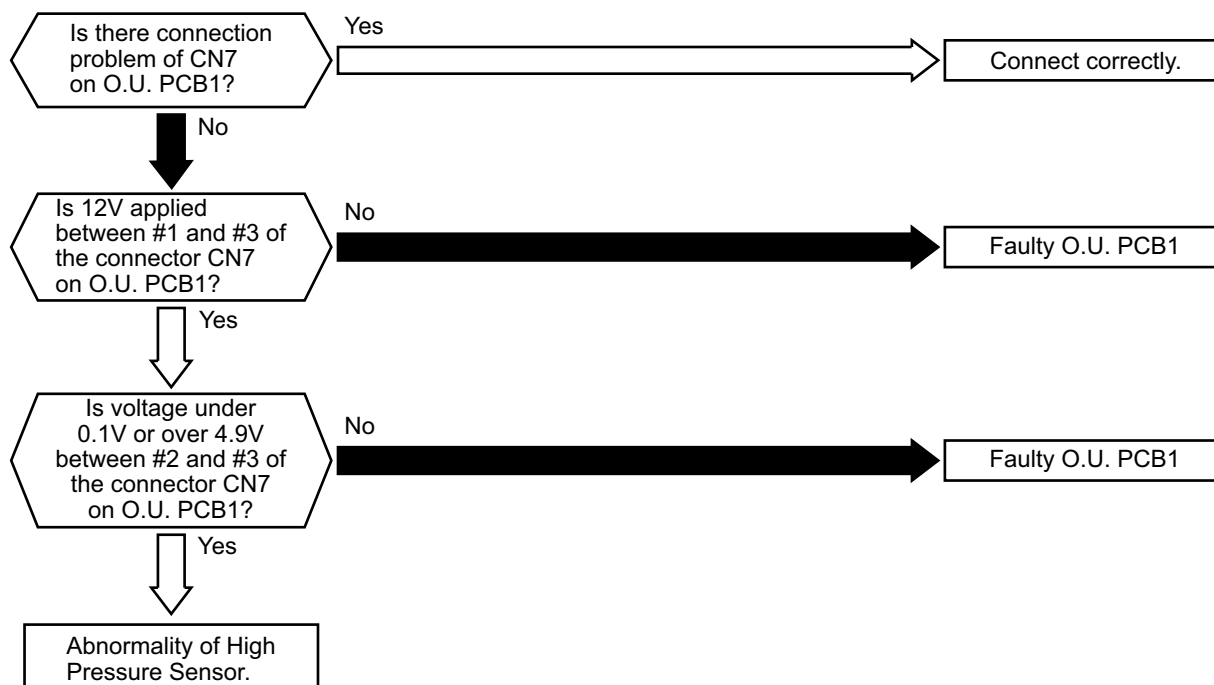

Phenomenon	Cause	Check item	Action (Turn OFF Main Switch)
Faulty top of compressor thermistor	Fault	Check resistance	Replace thermistor if faulty
	Incorrect connection	Check wiring to PCB1	Repair wiring and connections
Faulty PCB1		Replace PCB1 and check operation	Replace PCB1 if faulty
Indication of pressure value is excessively high or low	Malfunction of pressure sensor due to clogging wiring		Replace pressure sensor

8

Alarm code	22	Abnormal operation of the thermistor for the outdoor temperature (outdoor unit ambient thermistor)
------------	----	--

- The RUN LED flickers and “ALARM” is displayed on the remote control switch.
- The unit number, the alarm code and the unit code are alternately displayed on the set temperature section. The unit number and the alarm code are displayed on the display of the outdoor unit PCB.
 - This alarm code is displayed when the thermistor is short-circuited (less than 0.2 kΩ) or cut (greater than 500 kΩ) during the operation.

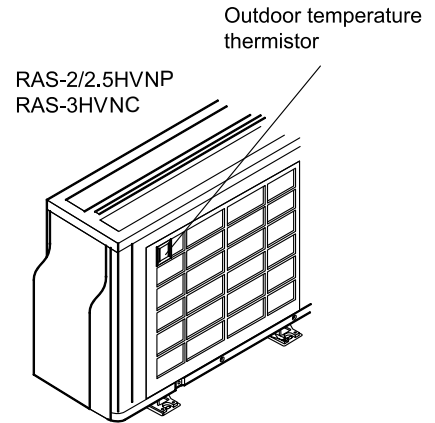
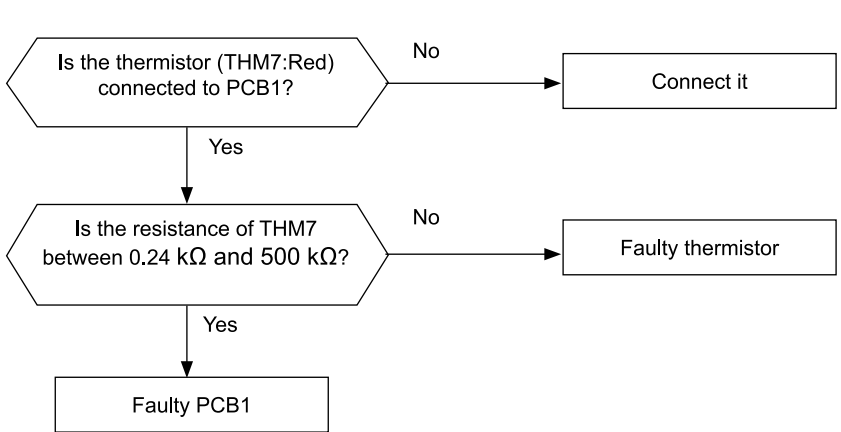

Thermistor characteristics

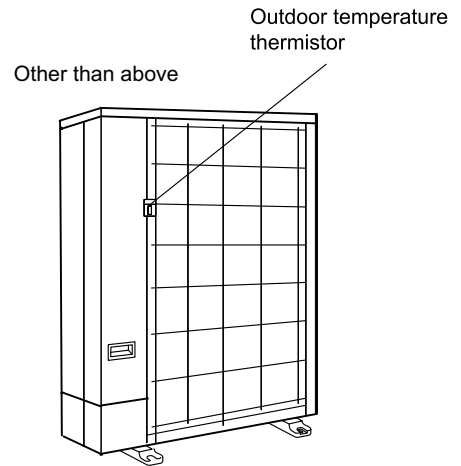
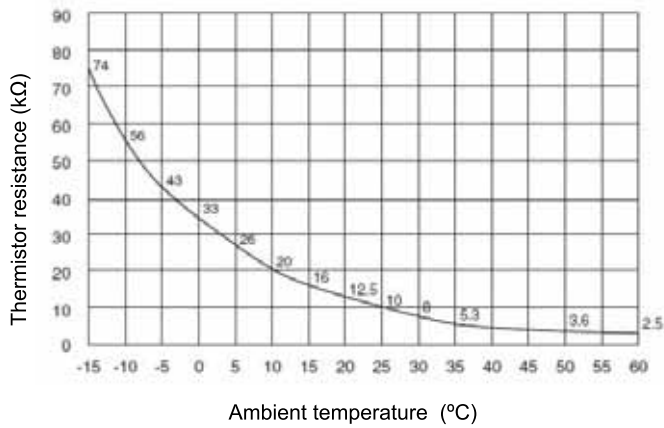

Phenomenon	Cause	Check item	Action (Turn OFF Main Switch)
Faulty thermistor for the outdoor unit ambient	Fault	Check resistance	Replace thermistor if faulty
	Incorrect connection	Check wiring to PCB	Repair wiring and connections
Faulty PCB1		Replace PCB1 and check operation	Replace PCB if faulty

Alarm code	24	Abnormal operation of the thermistor for the evaporating temperature during the heating process (outdoor unit)
------------	-----------	--

- The RUN LED flickers and “ALARM” is displayed on the remote control switch.
- The unit number, the alarm code and the unit code are alternately displayed on the set temperature section. The unit number and the alarm code are displayed on the display of the outdoor unit PCB. (*1)
If you find an abnormal operation of the thermistor, check all the thermistors as shown below.
 - The evaporating thermistor during the heating process is attached to the heat exchanger as shown in the figure below. If this the thermistor is faulty, such as short-circuit (less than 0,2kΩ) or cut (more than 500kΩ) during operation, this alarm is displayed. The position is indicated below.

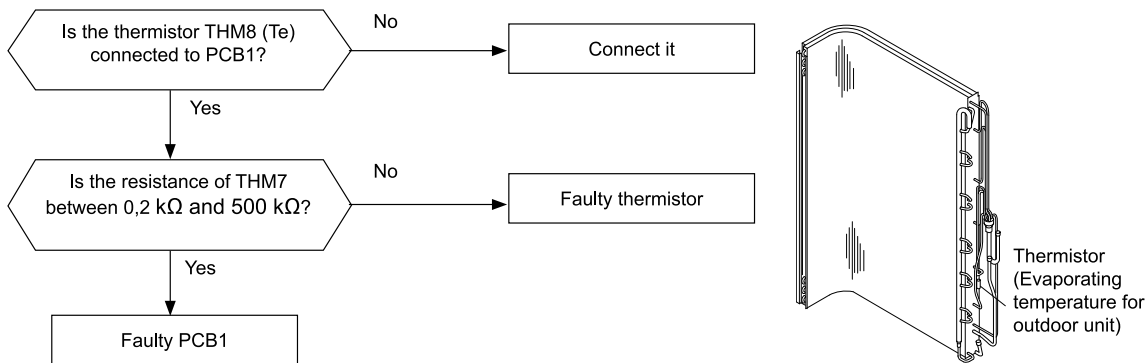

Phenomenon	Cause	Check item	Action (Turn OFF the main switch)
Faulty thermistor for the evaporating temperature during heating	Fault	Check the resistance	Replace the thermistor if faulty
	Incorrect Connection	Check the wiring to PCB	Repair the wiring and the connections
Faulty PCB		Replace PCB and check the operation	Replace PCB if faulty

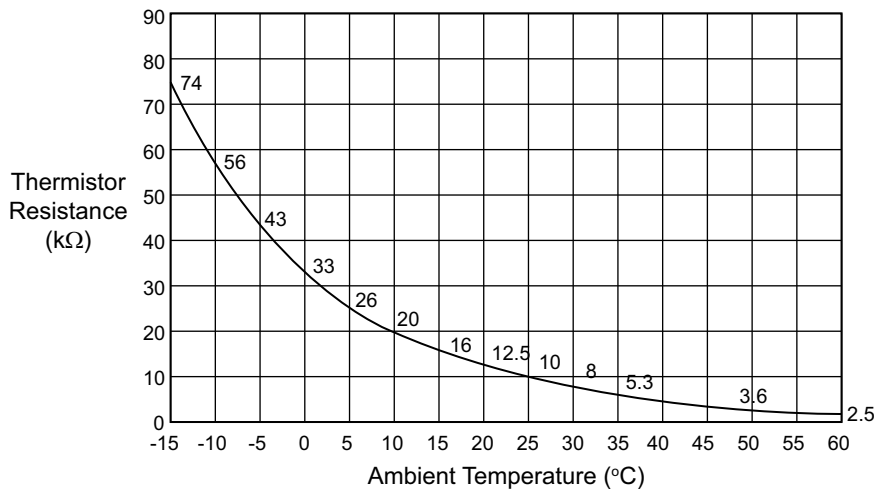

Ambient and Evaporating Temp. Thermistor Characteristics for Outdoor Unit



Alarm code

31

Incorrect Capacity Setting or Combined Capacity between Indoor Units and Outdoor Unit

- The RUN LED flickers and “ALARM” is displayed on the remote control switch.
- The unit number, the alarm code and the unit code are alternately displayed on the set temperature section. The unit number and the alarm code are displayed on the display of the outdoor unit PCB.
 - This alarm code is indicated when the undefined setting is set to DSW3 on the outdoor unit PCB.
 - This alarm code is indicated when the total indoor unit capacity is not equal to the combined outdoor unit capacity. Outdoor unit capacity setting is not correct

Conditions:

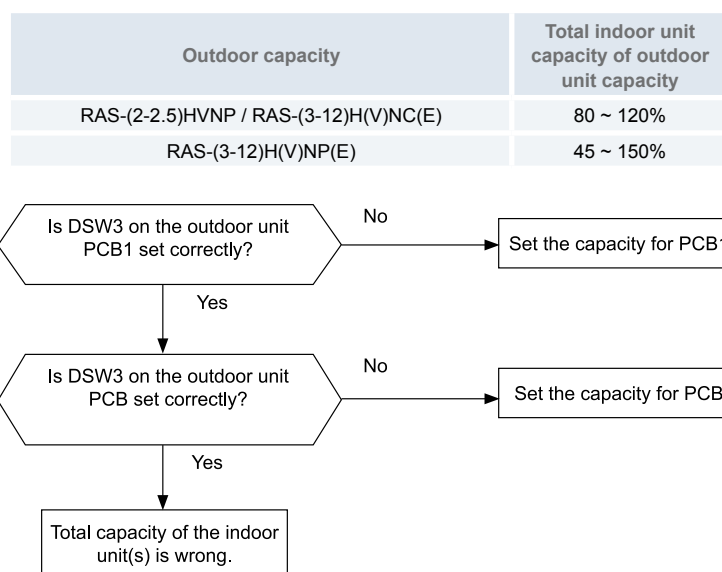

Phenomenon	Cause	Check item	Action (Turn OFF Main Switch)
Incorrect Capacity Setting of Indoor Unit		Check combination of indoor units and capacity setting on PCB.	Correctly set dip switch, DSW3.
Incorrect Capacity Setting of Outdoor Unit		Check capacity setting on outdoor unit PCB.	Correctly set dip switch, DSW3.
Total Indoor Unit Capacity Connected to the Outdoor Unit is Beyond Permissible Range		Check outdoor unit model by calculating total indoor units capacity.	Ensure that total indoor unit capacity agrees with the above capacity conditions.

**NOTE**

- **In case of H-LINK system, this alarm code is indicated when DSW4, RSW1 (for refrigerant system setting) on the outdoor unit PCB and DSW5, RSW2 (for refrigerant system setting) on the indoor unit PCB are incorrectly set.**
- **In this case, set correctly DSW4, RSW1, DSW5 and RSW2 after turning OFF main switch.**
- **(RSW2 is not equipped with some models.)**

Alarm code

35

Incorrect Indoor number setting

- The RUN LED flickers and “ALARM” is displayed on the remote control switch.
- The unit number, alarm code and unit model code appear alternately on the Set Temperature display of the remote control switch. The alarm code also appears on the outdoor unit PCB display.
 - The alarm code appears three minutes after the outdoor unit power activation if duplication is detected in indoor unit numbers connected to an outdoor unit (one refrigerant system). This applies when indoor unit numbers are configured using the rotary switch (RSW1).
 - The alarm code appears when the more than next indoor units are connected to one outdoor unit.

Model	Number of Indoor Units
RAS-3HVNPE RAS-(4-12)H(V)N(P/C)(E)	>11
RAS-(2-2.5)HVNP RAS-3HVNC	>5

- The alarm code appears when the indoor and outdoor unit refrigerant system and address are set to 64 or above. (In such a case, the alarm code “b1” appears on the remote control switch.)

**NOTE**

The alarm code may appear when H-LINK system is employed for indoor–outdoor unit transmission, if there is any incorrect setting in DSW4/RSW1 on the outdoor unit PCB and DSW5/RSW2 on the indoor unit PCB; which are dip switches used for refrigerant system setting. In such a case, turn OFF the power and correctly set DSW4/RSW1 on the outdoor unit PCB and DSW5/RSW2 on the indoor unit PCB before reactivating the power.

(Some indoor unit models do not have RSW2.)

Alarm code	38	Abnormality of Protective Circuit for Protection (Outdoor Unit)
------------	----	---

- The RUN LED flickers and “ALARM” is displayed on the remote control switch.
- The unit number, the alarm code and the unit code are alternately displayed on the set temperature section. The unit number and the alarm code are displayed on the display of the outdoor unit PCB.
 - The alarm code appears if approx. DC12V is supplied to the DIP-IPM connector (see table below) when the inverter operation is commanded (after five seconds following activation of the remote control switch).

Place the tester as shown in the diagram below to check the connector of PCN401. The connector shall remain inserted. DC12V will constantly be detected and disturb the diagnosis if the connector of PCN401 is pulled out.

RAS-(2-2.5)HVNP / RAS-3HVNC

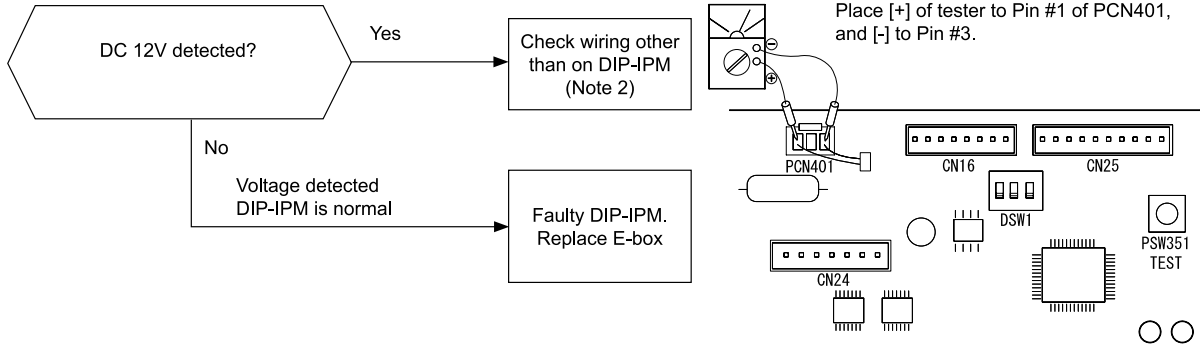

RAS-(3-6)H(V)N(P/C)E / RAS-(8-12)HN(P/C)(E)

- The alarm code appears if AC 200V or AC 240V is supplied to the connector on the outdoor unit PCB (see table below) while Y52C is OFF or CMC1 is open.

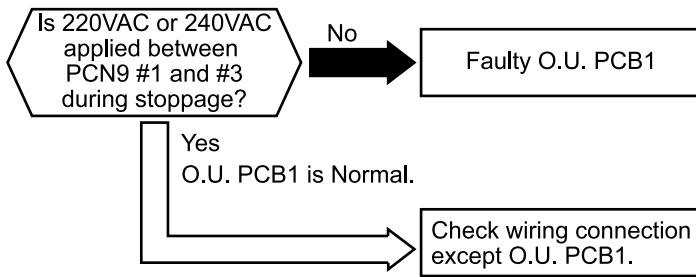

	Connector No. for Check
Connector	PCN9
Pin No.	#1 and #3

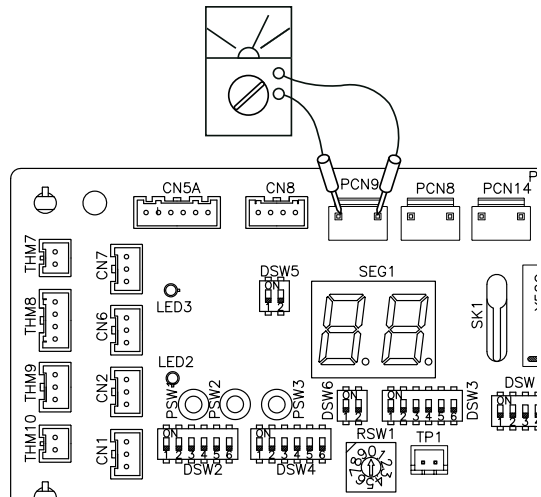

Phenomenon	Cause	Check item	Action (Turn OFF Main Switch)
Faulty DIP-IPM		Check DIP-IPM by self-checking	Replace DIP-IPM

NOTE

This alarm may appear if the Faston terminal of the high pressure switch (63H1) is improperly connected or damaged (open-circuit fault) when the operation is started. Besides this, check also “Alarm Code: 02 Activation of Outdoor Unit Protection Device”.

Alarm code

41

Cooling Overload (High pressure switch will be activated) for RAS-(2-2.5)HVNP and RAS-3HVNC

- The RUN LED flickers and “ALARM” is displayed on the remote control switch.
- The unit number, the alarm code and the unit code are alternately displayed on the set temperature section. The unit number and the alarm code are displayed on the display of the outdoor unit PCB.
 - Abnormality indication will appear when the protection device is activated during compressor operation at cooling (see Note), with the outdoor unit evaporation temperature higher than 55 °C AND the compressor-top temperature higher than 95 °C.

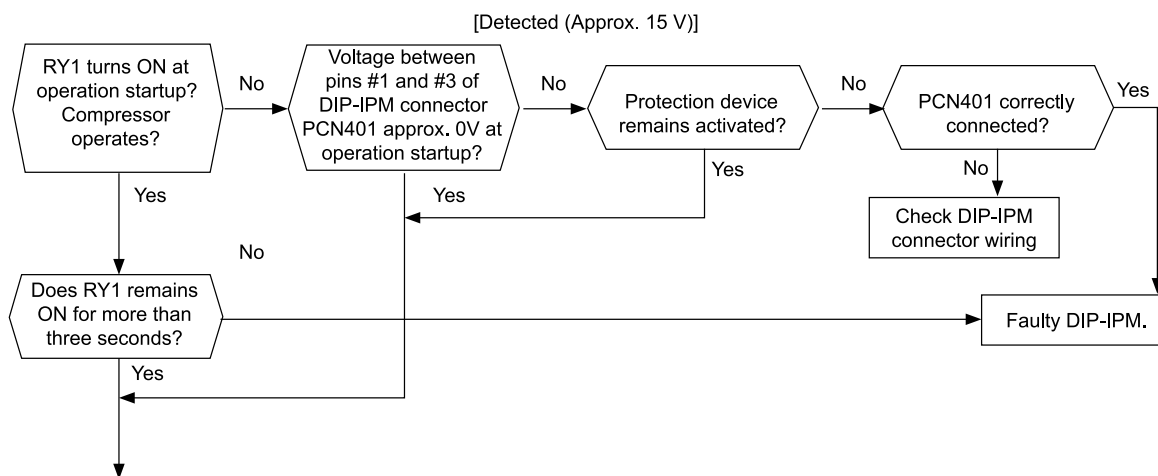

Check the temperature of the following places with the remote control switch in checking mode.
 Check the temperature of [1] compressor-top temperature and [2] outdoor unit liquid refrigeran piping. Examine the cause and address the problem if the measurements surpass the preset temperature. (See Note)

- 1 Compressor-Top Temp.Preset Temp. 95°C
- 2 Indoor unit liquid refrigerant piping temp. Preset Temp. 55°C

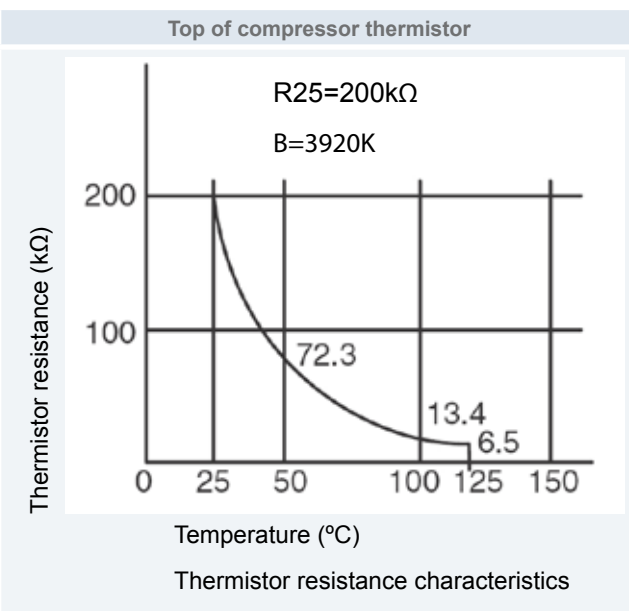
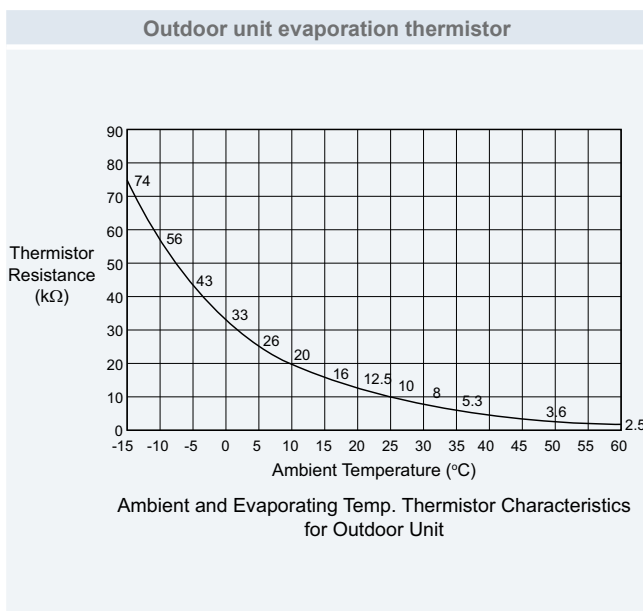

8

Phenomenon	Cause	Check item	Action (Turn OFF main switch)	
Activation of High Pressure Switch due to Excessively High Discharge Pressure during Cooling Operation	Insufficient Air Flow to Heat Exchanger of Outdoor Unit	Clogging of Heat Exchanger?	Remove clogging	
		Check for dust on air filter	Remove dust	
		Check the service space	Secure service space	
		Check for outdoor fan speed	Replace fan motor if faulty	
	Excessively High Temp. Air to Outdoor Unit Heat Exchanger	Check for hot air near the ceiling	Make good circulation	
		Check for short circuited air	Remove short-circuited air	
		Check for other heat source	Remove heat source	
	Faulty High Pressure Switch	Faulty Pressure Switch	Measure discharge pressure.	Replace it if faulty
			Check continuity after decreasing of pressure	
		Insufficient Contacting	Measure resistance by tester	Repair looseness. Replace connector
	Incorrect Connection		Check connections	Repair connections
	Overcharged Refrigerant	Check cycle operating temp.	Charge refrigerant correctly	
	Mixture of Non-Condensable Gas in Refrigerant Cycle	Check ambient temp. and pressure	Recharge refrigerant after vacuum pumping	
	Clogging of Discharge Piping	Check for clogging	Remove clogging	
	Faulty or Malfunction of Expansion Valve	Check for clogging	Remove clogging	
		Check connecting wiring and connectors	Replace connector	
		Check operating sound from coil	Replace coil	
		Check discharge gas thermistor	Replace thermistor	
Check attaching state of discharge gas thermistor		Reattach thermistor		
Liquid Line Stop Valve or Gas Line Stop Valve are not in Operation	Check stop valves	Fully open stop valve		
Locking up Outdoor Unit Expansion Valve Closure	Check expansion valve actuation	Replace outdoor expansion valve		

**NOTE**

This alarm code is indicated when the outdoor unit protective device is activated by high discharge pressure during cooling operation. Accordingly, when this alarm code is indicated, there is high possibility of high pressure switch actuation and the above troubleshooting actions are based on such cases.

Alarm code	42	Heating Overload (High pressure switch will be activated) for RAS-(2-2.5)HVNP and RAS-3HVNC
------------	-----------	---

- The RUN LED flickers and “ALARM” is displayed on the remote control switch.
- The unit number, the alarm code and the unit code are alternately displayed on the set temperature section. The unit number and the alarm code are displayed on the display of the outdoor unit PCB.
 - Abnormality indication will appear when the protection device is activated during compressor operation at heating (see Note), with the outdoor unit evaporation temperature higher than 55 °C and the compressor-top temperature higher than 95 °C.

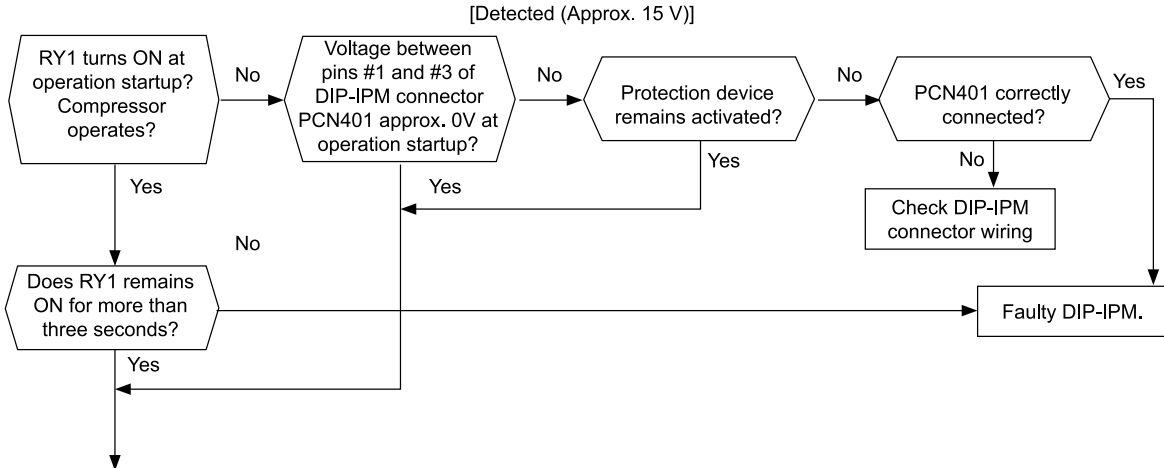

Check the temperature of the following places with the remote control switch in checking mode.
 Check the temperature of [1] compressor-top temperature and [2] outdoor unit liquid refrigerant piping. Examine the cause and address the problem if the measurements surpass the preset temperature. (See Note)

- 1 Compressor-Top Temp. Preset Temp. 95°C
- 2 Indoor unit liquid refrigerant piping temp. Preset Temp. 55°C

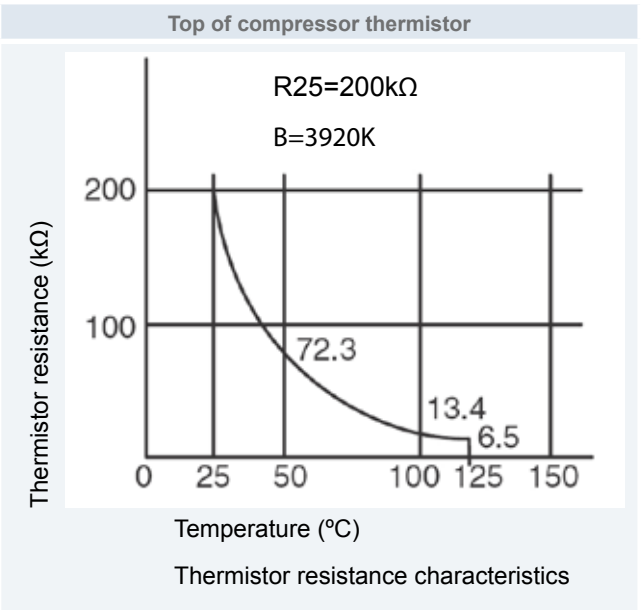
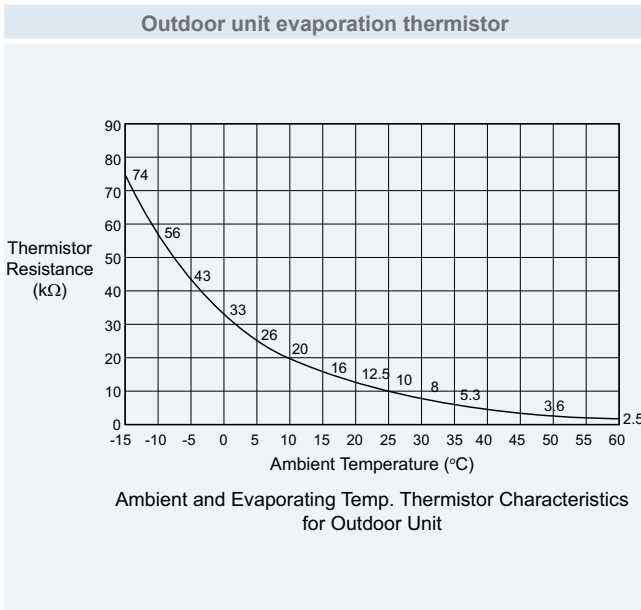

Phenomenon	Cause		Check item	Action (Turn OFF Main Switch)	
Activation of High Pressure Switch due to Excessively High Discharge Pressure during Heating Operation	Insufficient Air Flow to Heat Exchanger of Indoor Unit		Clogging of Heat Exchanger	Remove it	
			Check for dust on air filter		
			Check for any obstacle at inlet or outlet of heat exchanger		
			Check the service space		Secure service space
			Check for indoor fan speed		Replace fan motor if faulty
Activation of High Pressure Switch due to Excessively High Discharge Pressure during Heating Operation	Excessively High Temp. Air to Indoor Unit Heat Exchanger		Calculate heat load.	Reduce heat load or use a bigger unit	
			Check for hot air near the ceiling	Make good circulation	
			Check for short circuited air	Remove short-circuited air	
			Check for other heat source	Remove heat source	
	Faulty High Pressure Switch	Faulty Pressure Switch	Measure discharge pressure. Check continuity after decreasing of pressure	Replace it if faulty	
		Insufficient Contacting	Measure resistance by tester	Repair looseness. Replace connector	
		Incorrect Connection	Check connections	Repair connections	
	Faulty of Outdoor Fan Control		Check decreasing air flow volume at pressure switch for control activative	Replace thermistor for evaporating temp. if faulty	
	Faulty of Pressure Switch for Control		Check activated pressure and connecting wire	Replace it if pressure switch for control is faulty	
	Overcharged Refrigerant		Check cycle operating temp.	Charge refrigerant correctly	
	Mixture of Non-Condensable Gas in Refrigerant Cycle		Check ambient temp. and pressure	Recharge refrigerant after vacuum pumping	
	Clogging of Discharge Piping		Check for clogging	Remove clogging	
	Faulty or Malfunction of Expansion Valve		Check for clogging	Remove clogging	
			Check connecting wiring and connectors	Replace connector	
			Check operating sound from coil	Replace coil	
			Check discharge gas thermistor	Replace thermistor	
			Check attaching state of discharge gas thermistor	Reattach thermistor	
	Liquid Line Stop Valve or Gas Line Stop Valve are not in Operation		Check stop valves	Fully open stop valve	

 **NOTE**

This alarm code is indicated when the outdoor unit protective device is activated by high discharge pressure during heating operation. Accordingly, when this alarm code is indicated, there is high possibility of high pressure switch actuation and the above troubleshooting actions are based on such cases.

Alarm code

45

Activation of high pressure increase protection device

- The RUN LED flickers and “ALARM” is displayed on the remote control switch.
- The unit number, the alarm code and the unit code are alternately displayed on the set temperature section. The unit number and the alarm code are displayed on the display of the outdoor unit PCB.
 - When the compressor is operated with the discharge pressure (Pd) higher than 3.8MPa for 1 minute, the retry operation is performed 3 minutes after all compressors are stopped. Thereafter, this alarm code is indicated when above abnormality is detected twice in 30 minutes.

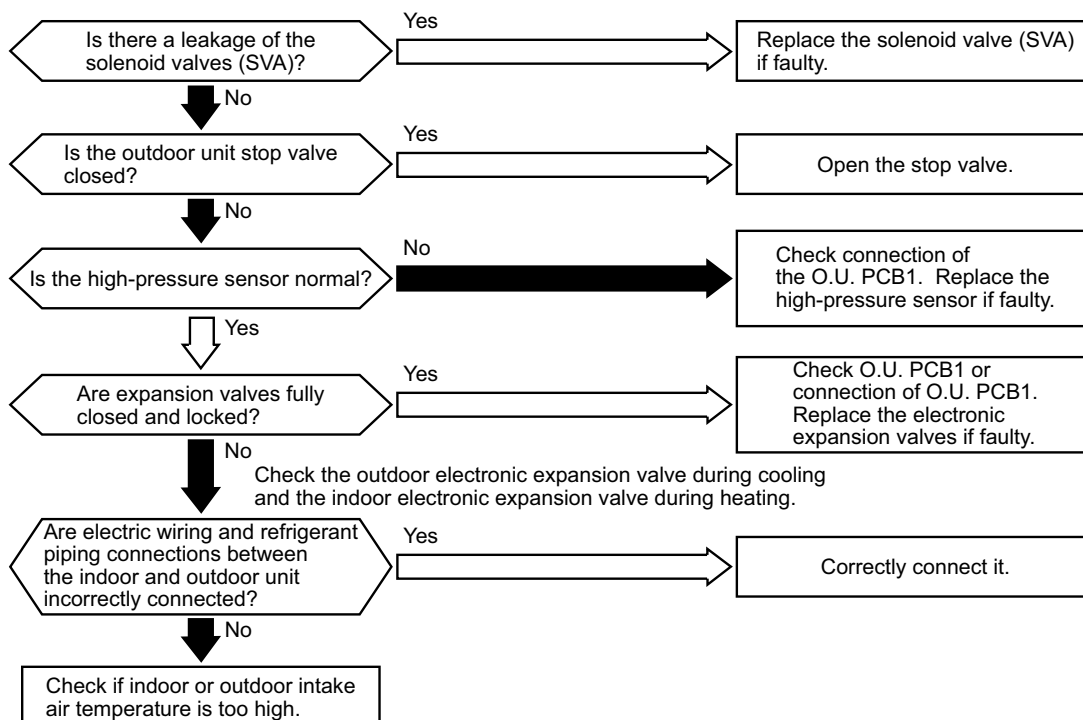

Phenomenon	Cause	Check Item	Action (Turn OFF Main Switch)
Excessively High Discharge Pressure	Leakage of Solenoid Valve (SVA)	Check outlet temp. of solenoid valve (SVA).	Check connection. Replace solenoid valve (SVA) if faulty.
	Closed Stop Valve	Check stop valve.	Open stop valve.
	Abnormal High Pressure Sensor	Check connecting condition and output voltage of connector "CN100" (on O.U. PCB1) for high pressure sensor.	Replace high pressure sensor if faulty.
	Excessively High Temperature of Inlet Air for Outdoor Unit or Indoor Unit	Check thermistor for indoor unit and outdoor unit inlet air temp.	Replace inlet air thermistor if faulty.
	Incorrect Connection between Indoor Unit and Outdoor Unit	Check electrical system and ref. cycle system.	Correctly connect.
	Locked Expansion Valve with Fully Closed	Check condition of connector "CN100" on O.U. PCB1.	Repair connector for O.U. PCB1 or expansion valve. Replace it if faulty.

Alarm code

47

Activation to Protect System from Excessively Low Suction Pressure (Protection from Vacuum Operation)

- The RUN LED flickers and “ALARM” is displayed on the remote control switch.
- The unit number, the alarm code and the unit code are alternately displayed on the set temperature section. The unit number and the alarm code are displayed on the display of the outdoor unit PCB.
 - In the case that the evaporating temperature (Cooling: Liquid Refrigerant Piping Temp. of Indoor Unit, Heating: Evaporating Temp. of Outdoor Unit) is lower than $-37\text{ }^{\circ}\text{C}$ ($250\sim 350\text{ k}\Omega$) and the thermistor on top of compressor is higher than $90\text{ }^{\circ}\text{C}$. for 10 minutes, retry operation is performed 3 minutes after compressor stoppage. However, when the state occurs more than 3 times including 3 in one hour, this alarm code is indicated.

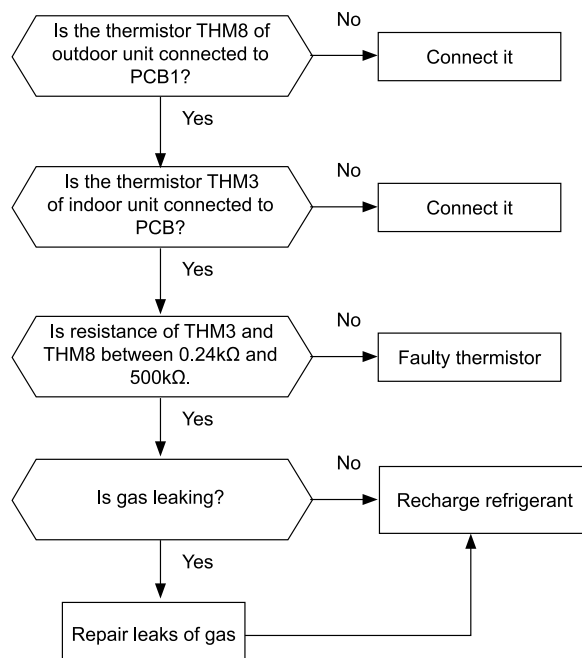

Phenomenon	Cause	Check item	Action (Turn OFF Main Switch).
- Faulty indoor unit liquid refrigerant temp. thermistor	Fault	Check resistance.	Replace thermistor if faulty.
	Incorrect Connection	Check wiring to PCB.	Repair wiring and connections.
- Faulty outdoor unit evaporating temp. thermistor			
Faulty PCB (Outdoor Unit, Indoor Unit)		Replace PCB and check operation.	Replace PCB if faulty.
Excessively Low Suction Pressure (in Vacuum)	Liquid Line Stop Valve is not open before Operation	Check stop valve.	Fully open stop valve.
	Faulty or Malfunction of Expansion Valve	Check for clogging.	Remove clogging.
		Check connecting wiring and connectors.	Replace connector.
		Check operating sound from coil.	Replace coil.
		Check discharge gas thermistor.	Replace thermistor.
	Check attaching state of discharge gas thermistor.	Reattach thermistor.	
	Refrigerant Leakage	Check each temp. and pressure.	Charge refrigerant after vacuum pumping.
Check gas leakage part.		Correctly charge refrigerant after repairing gas leakage.	
Faulty Outdoor Fan at heating Operation	Faulty Outdoor Fan Motor	Measure coil resistance and insulating resistance.	Replace outdoor fan motor if faulty.

Alarm code

48

Overcurrent protection activation for RAS-(2-2.5)HVNP and RAS-3HVNC

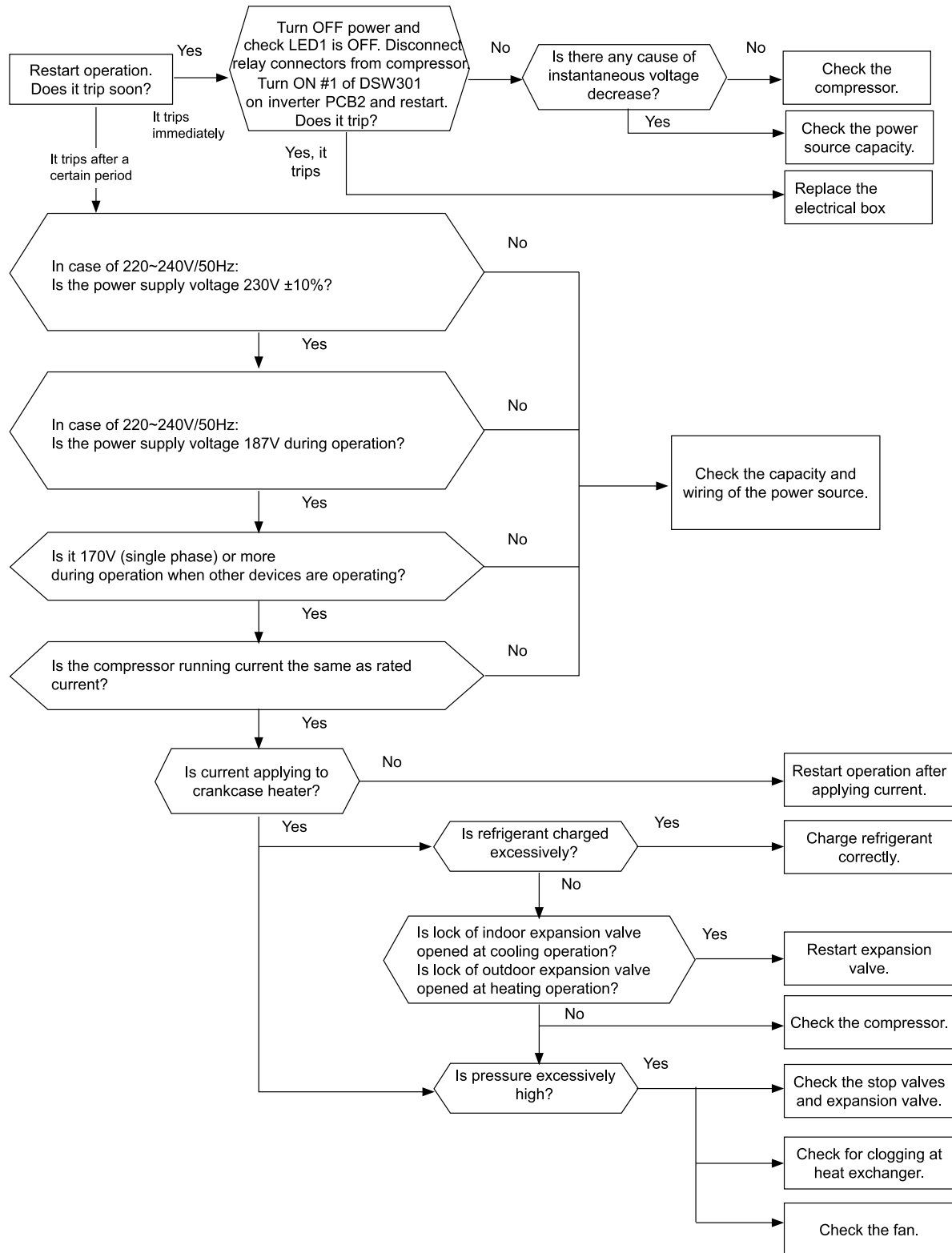

Alarm code

48

Overcurrent protection activation for RAS-(3-12)H(V)N(P/C)(E)

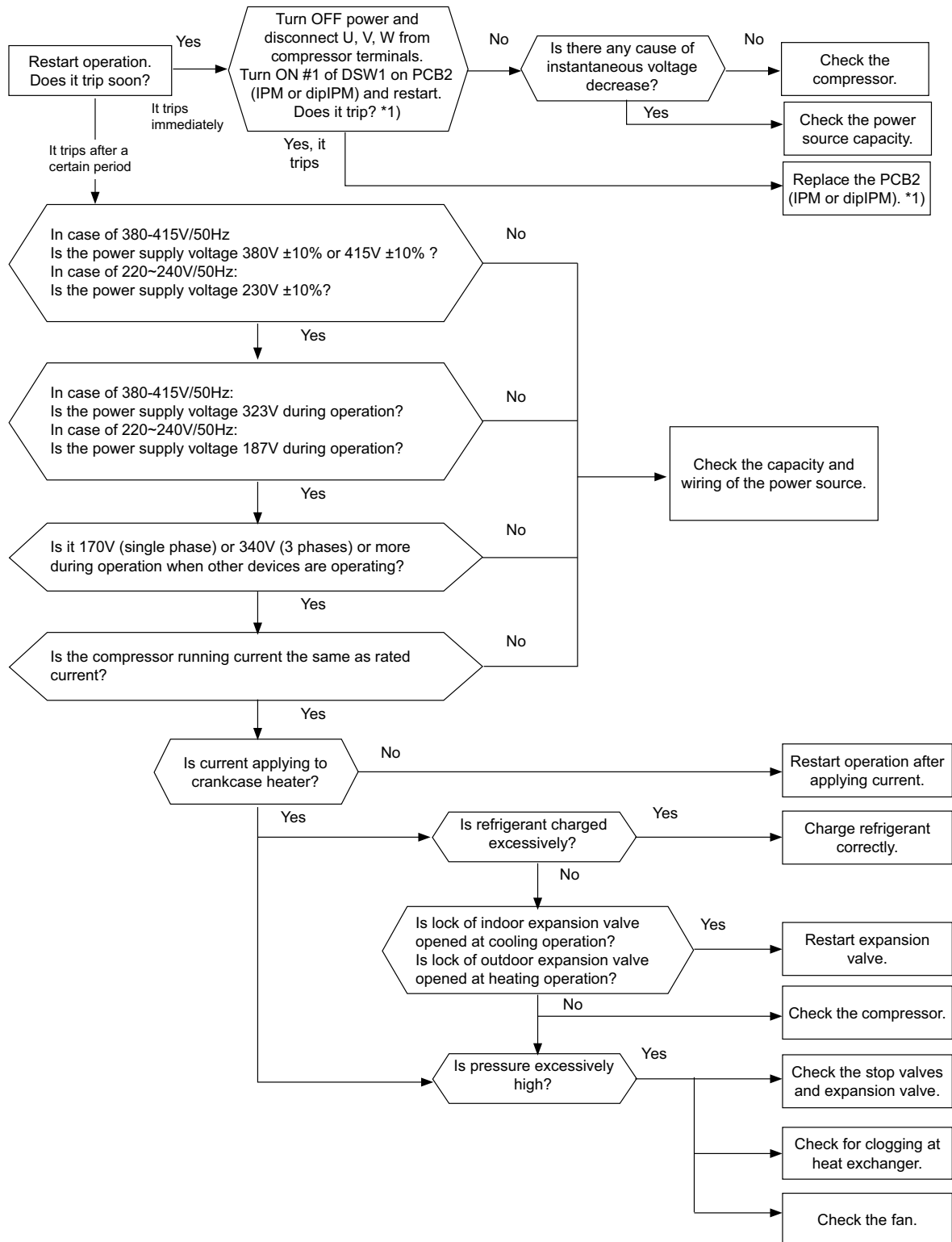

NOTE

*1) Perform the high voltage discharge work by referring to section [Procedure of checking other main parts](#) before checking and replacing the inverter PCB.

Alarm code

51

Abnormal operation of the current sensor (RAS-(2-2.5)HVNP / RAS-3HVNC)

- The RUN LED flickers and “ALARM” is displayed on the remote control switch.
- The unit number, the alarm code and the unit code are alternately displayed on the set temperature section. The unit number and the alarm code are displayed on the display of the outdoor unit PCB.
 - This alarm code is displayed when the current transformer is abnormal (0 A detection or 3 A alarm condition) and the alarm has more than three occurrences in 30 minutes.
 - Condition of Activation:
 - ♦ When the frequency of the compressor is maintained at 6~10 Hz after the compressor is started, one of the absolute values of the running current at each phase U+, U-, V+ and V- is less than 1.5 A (including 1.5A)
 - ♦ Before the compressor is operated (at the end of position control), the current wave value is less than 3.0 A

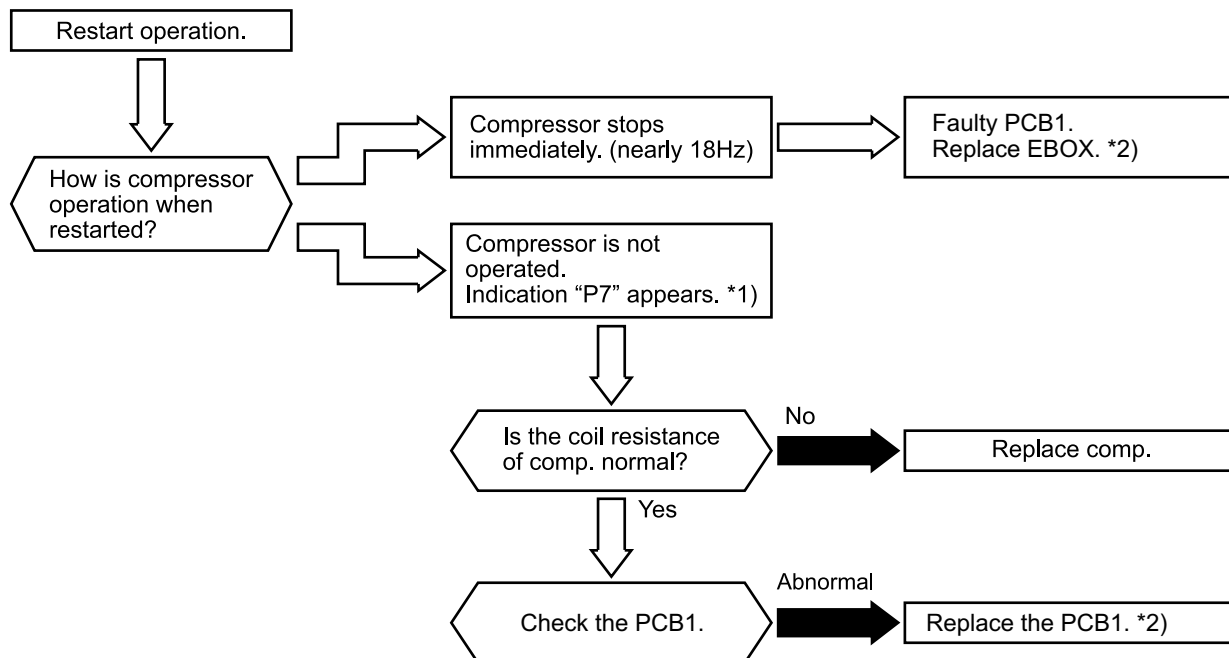

i NOTE

- *1) P7 is shown at 7-segment on the outdoor unit PCB.
- *2) Make sure LED1 is OFF.

Alarm code

51

Abnormal operation of the current sensor (RAS-(3-6)H(V)N(P/C)E)

- The RUN LED flickers and “ALARM” is displayed on the remote control switch.
- The unit number, the alarm code and the unit code are alternately displayed on the set temperature section. The unit number and the alarm code are displayed on the display of the outdoor unit PCB.
 - This alarm code is displayed when the current transformer is abnormal (0 A detection or 5 A alarm condition) and the alarm has more than three occurrences in 30 minutes.
 - Condition of Activation:
 - ♦ When the frequency of the compressor is maintained at 15~18 Hz after the compressor is started, one of the absolute values of the running current at each phase U+, U-, V+ and V- is less than 1.5 A (including 1.5A)
 - ♦ Before the compressor is operated (at the end of position control), the current wave value is less than 5.0 A

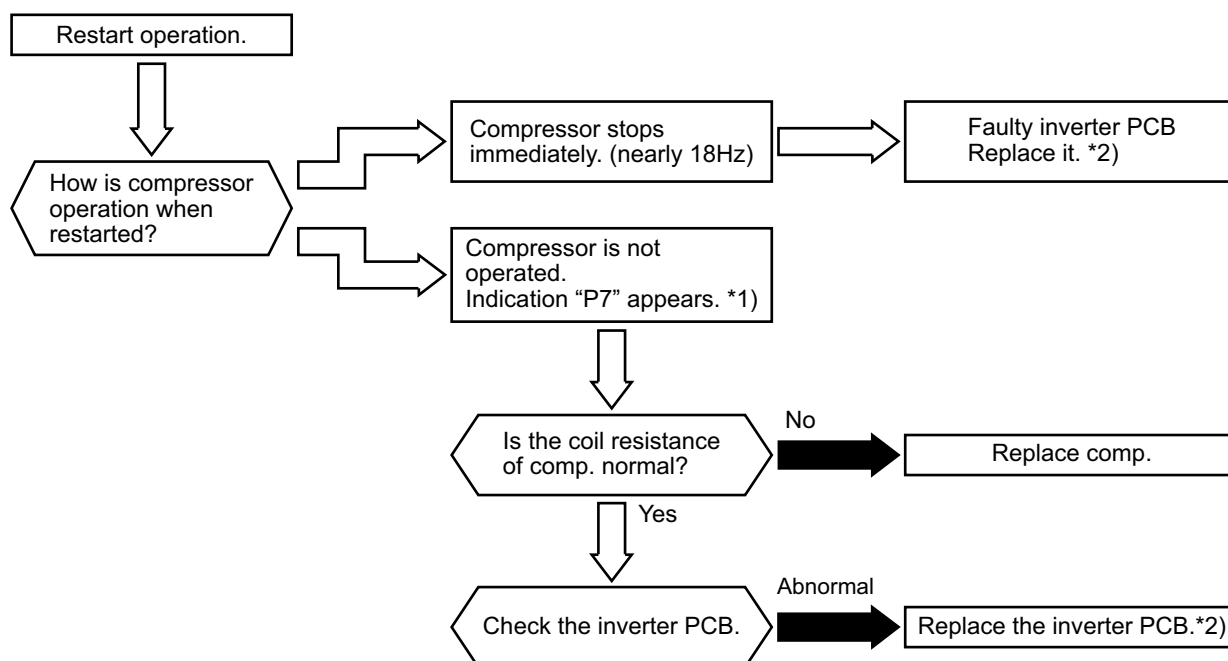

NOTE

- *1) P7 is shown at 7-segment on the outdoor unit PCB.
- *2) Perform the high voltage discharge work by referring to the item [Procedure of checking other main parts](#), in part “Checking procedure for the electronic expansion valve” before checking and replacing the inverter parts.

Alarm code

51

Abnormal operation of the current sensor (RAS-(8-12)HN(P/C)(E))

- The RUN LED flickers and “ALARM” is displayed on the remote control switch.
- The unit number, the alarm code and the unit code are alternately displayed on the set temperature section. The unit number and the alarm code are displayed on the display of the outdoor unit PCB.
 - This alarm code is displayed when the current transformer is abnormal (0 A detection or 5 A alarm condition) and the alarm has more than three occurrences in 30 minutes.
 - Condition of Activation:
 - ♦ When the frequency of the compressor is maintained at 15~18 Hz after the compressor is started, one of the absolute values of the running current at each phase U+, U-, V+ and V- is less than 1.5 A (including 1.5A)
 - ♦ Before the compressor is operated (at the end of position control), the current wave value is less than 5.0 A

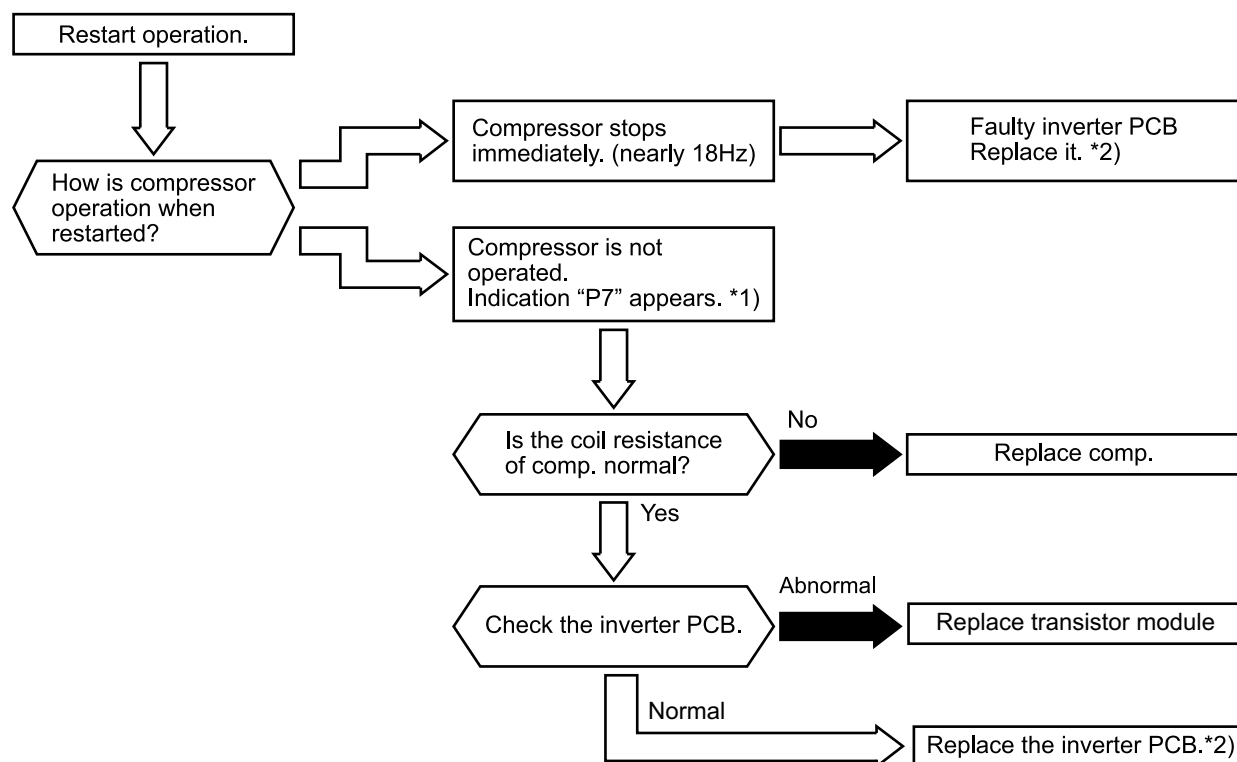

NOTE

- *1) P7 is shown at 7-segment on the outdoor unit PCB.
- *2) Perform the high voltage discharge work by referring to the item [Procedure of checking other main parts](#), in part “Checking procedure for the electronic expansion valve” before checking and replacing the inverter parts.

Alarm code

53

Activation of transistor module (RAS-(2-2.5)HVNP / RAS-3HVNC)

- The RUN LED flickers and “ALARM” is displayed on the remote control switch.
- The unit number, the alarm code and the unit code are alternately displayed on the set temperature section. The unit number and the alarm code are displayed on the display of the outdoor unit PCB.
 - ISPM has a detection function of the abnormal operation. This alarm is displayed when the ISPM module detects the abnormal operation 7 times or more than 7 times in 30 minutes. The retry operation is performed six times.

Conditions:

- The abnormal current to the ISPM, such as short-circuited, grounded, overcurrent or control voltage decrease.

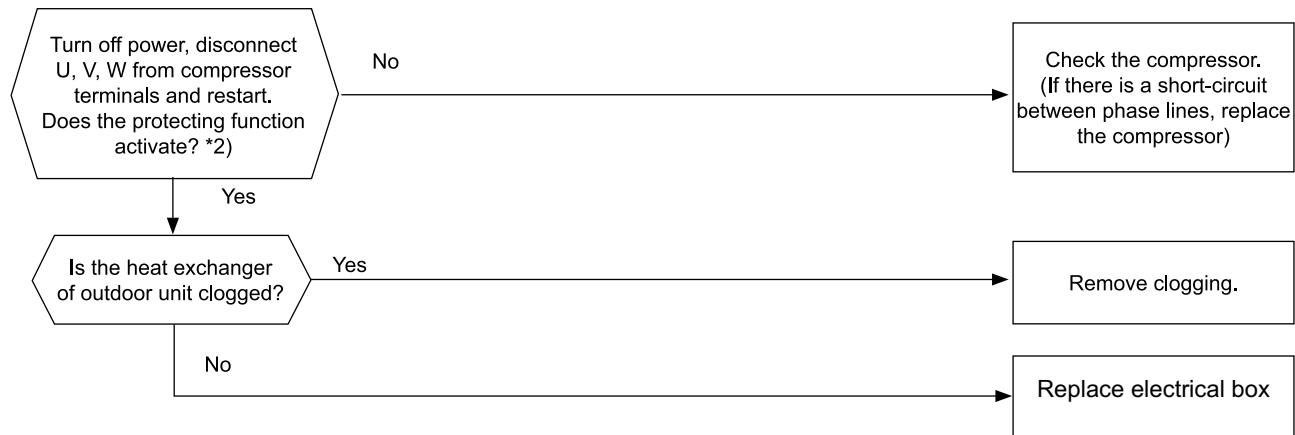
**NOTE**

- *1) Regarding replacing or checking method for ISPM, refer to item [Procedure of checking other main parts](#).
- *2) Set the #1 pin of DIP switch on ISPM to ON when you are restarting with the terminals of the compressor disconnected. After the troubleshooting, set #1 pin of DIP switch DSW1 on ISPM to OFF.

Alarm code

53

Activation of transistor module (RAS-3HVNPE / RAS-(4-6)H(V)NCE)

- The RUN LED flickers and “ALARM” is displayed on the remote control switch.
- The unit number, the alarm code and the unit code are alternately displayed on the set temperature section. The unit number and the alarm code are displayed on the display of the outdoor unit PCB.
 - IPM or Dip IPM and PCB2 have detecting function of abnormality. This alarm is indicated when the transistor module detect the abnormality 7 times in 30 minutes including 7. Retry operation is performed up to the occurrence of 6 times.

Conditions:

- The abnormal current such as short circuited, grounded or the overcurrent occurs at the transistor module.
- The temperature at transistor module increases abnormally.
- The control voltage decreases.
- The angle difference between the shaft in compressor and the shaft in the control program exceeds +60deg.

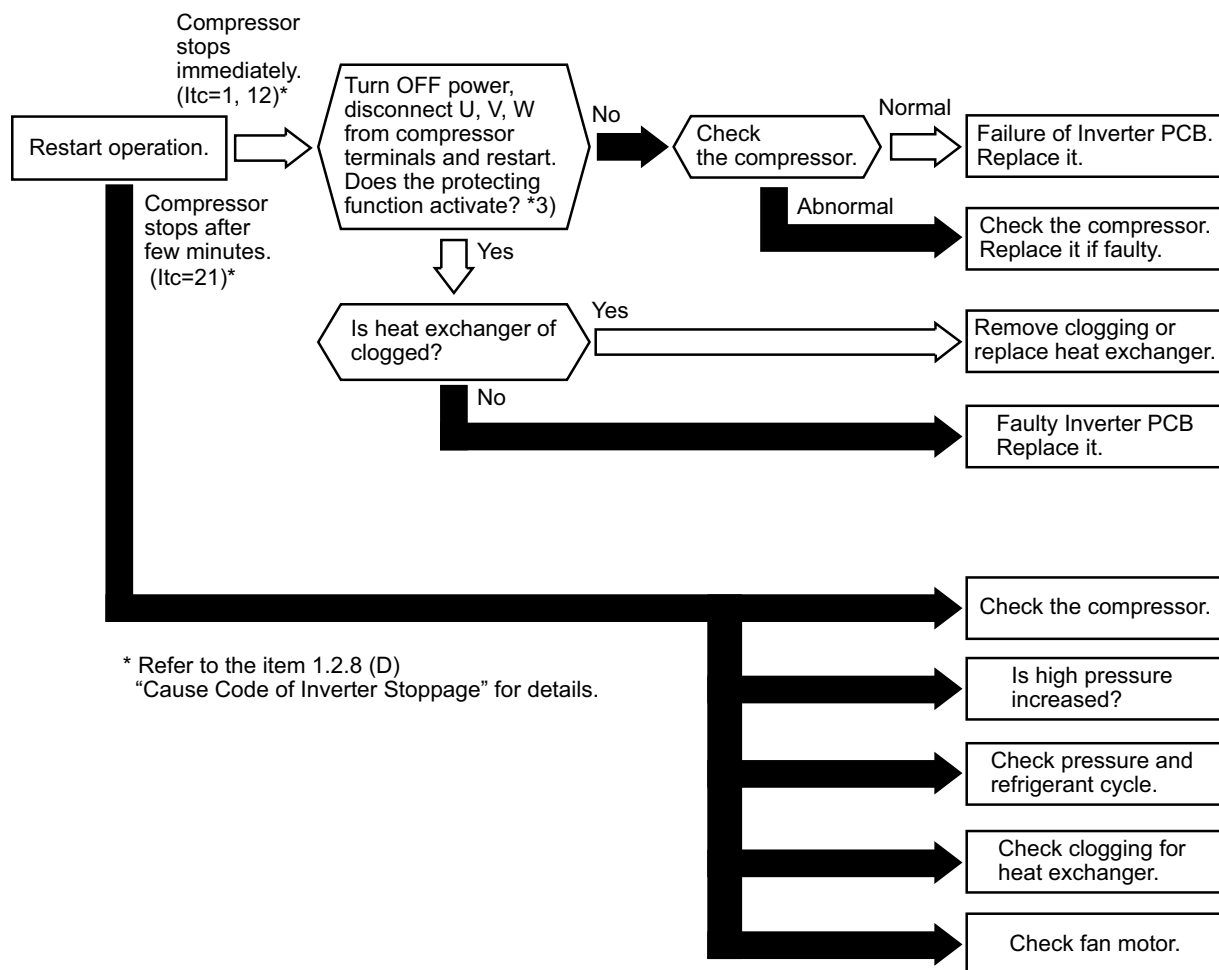

8

**NOTE**

- *1) Perform the high voltage discharge work by referring to the item [Procedure of checking other main parts](#), before checking and replacing the inverter components.
- *2) Regarding replacing or checking method for inverter components, refer to item [Procedure of checking other main parts](#).
- *3) Turn ON the No.1 switch of the dip switch DSW1 on PCB2 (inverter) when restarting with disconnecting the terminals of the compressor. After troubleshooting, turn OFF the No.1 switch of the dip switch DSW1 on PCB2.
- When the alarm code “53” is indicated, the outdoor fan motor (DC motor) ensure that DC fan motor is checked according to the item [Procedure of checking other main parts](#).

Alarm code

53

Activation of transistor module (RAS-(4-6)H(V)NPE)

- The RUN LED flickers and “ALARM” is displayed on the remote control switch.
- The unit number, the alarm code and the unit code are alternately displayed on the set temperature section. The unit number and the alarm code are displayed on the display of the outdoor unit PCB.
 - IPM or Dip IPM and PCB2 have detecting function of abnormality. This alarm is indicated when the transistor module detect the abnormality 7 times in 30 minutes including 7. Retry operation is performed up to the occurrence of 6 times.

Conditions:

- The abnormal current such as short circuited, grounded or the overcurrent occurs at the transistor module.
- The temperature at transistor module increases abnormally.
- The control voltage decreases.
- The angle difference between the shaft in compressor and the shaft in the control program exceeds +60deg.

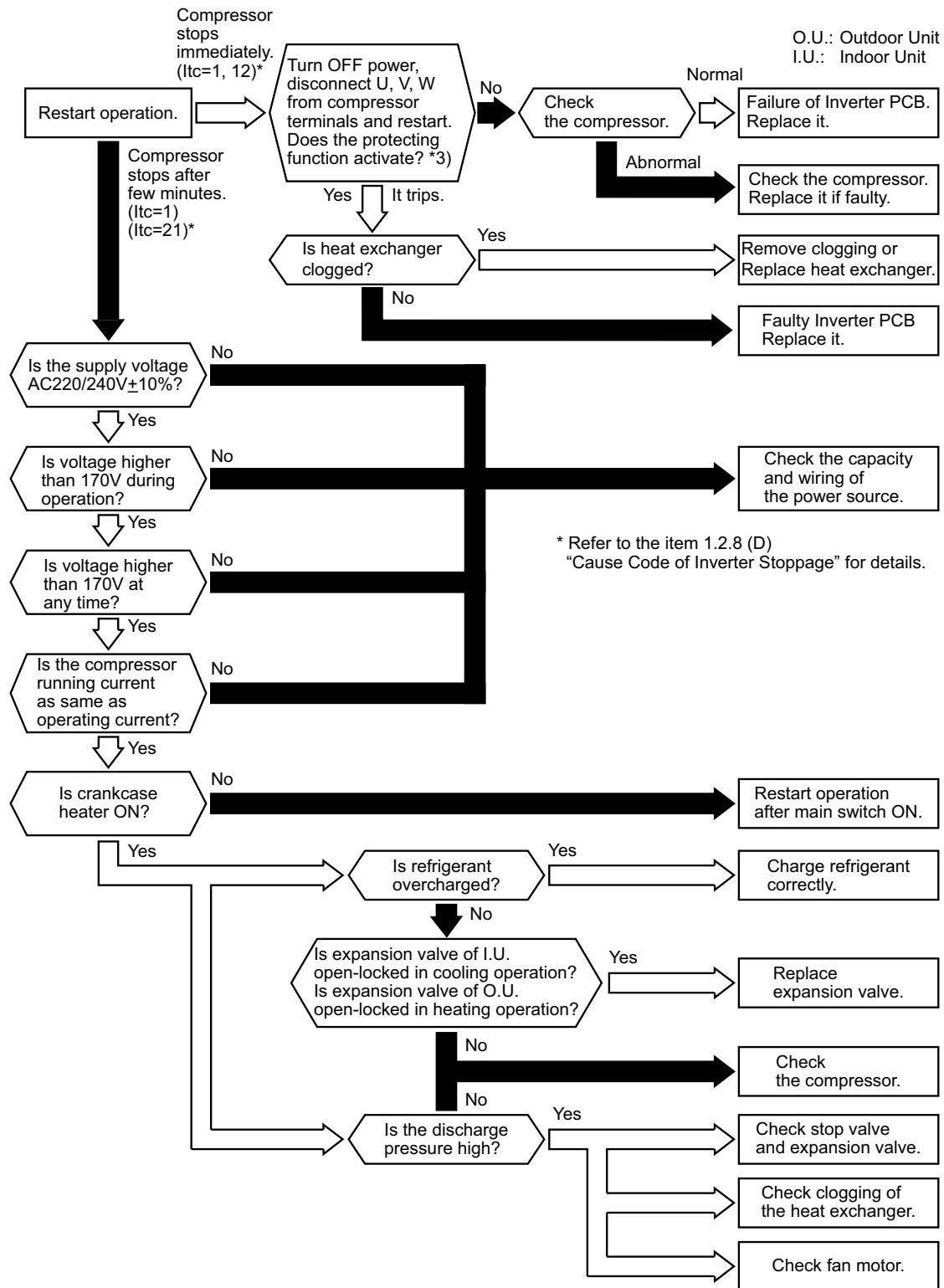

NOTE

- *1) Perform the high voltage discharge work by referring to the item [Procedure of checking other main parts](#), before checking and replacing the inverter components.
- *2) Regarding replacing or checking method for inverter components, refer to item [Procedure of checking other main parts](#).
- *3) Turn ON the No.1 switch of the dip switch DSW1 on PCB2 (inverter) when restarting with disconnecting the terminals of the compressor. After troubleshooting, turn OFF the No.1 switch of the dip switch DSW1 on PCB2.
- When the alarm code "53" is indicated, the outdoor fan motor (DC motor) ensure that DC fan motor is checked according to the item [Procedure of checking other main parts](#).

Alarm code

53

Activation of transistor module (RAS-(8-12)HN(P/C)(E))

- The RUN LED flickers and “ALARM” is displayed on the remote control switch.
- The unit number, the alarm code and the unit code are alternately displayed on the set temperature section. The unit number and the alarm code are displayed on the display of the outdoor unit PCB.
 - IPM or Dip IPM and PCB2 have detecting function of abnormality. This alarm is indicated when the transistor module detect the abnormality 7 times in 30 minutes including 7. Retry operation is performed up to the occurrence of 6 times.

Conditions:

- The abnormal current such as short circuited, grounded or the overcurrent occurs at the transistor module.
- The temperature at transistor module increases abnormally.
- The control voltage decreases.
- The angle difference between the shaft in compressor and the shaft in the control program exceeds +60deg.

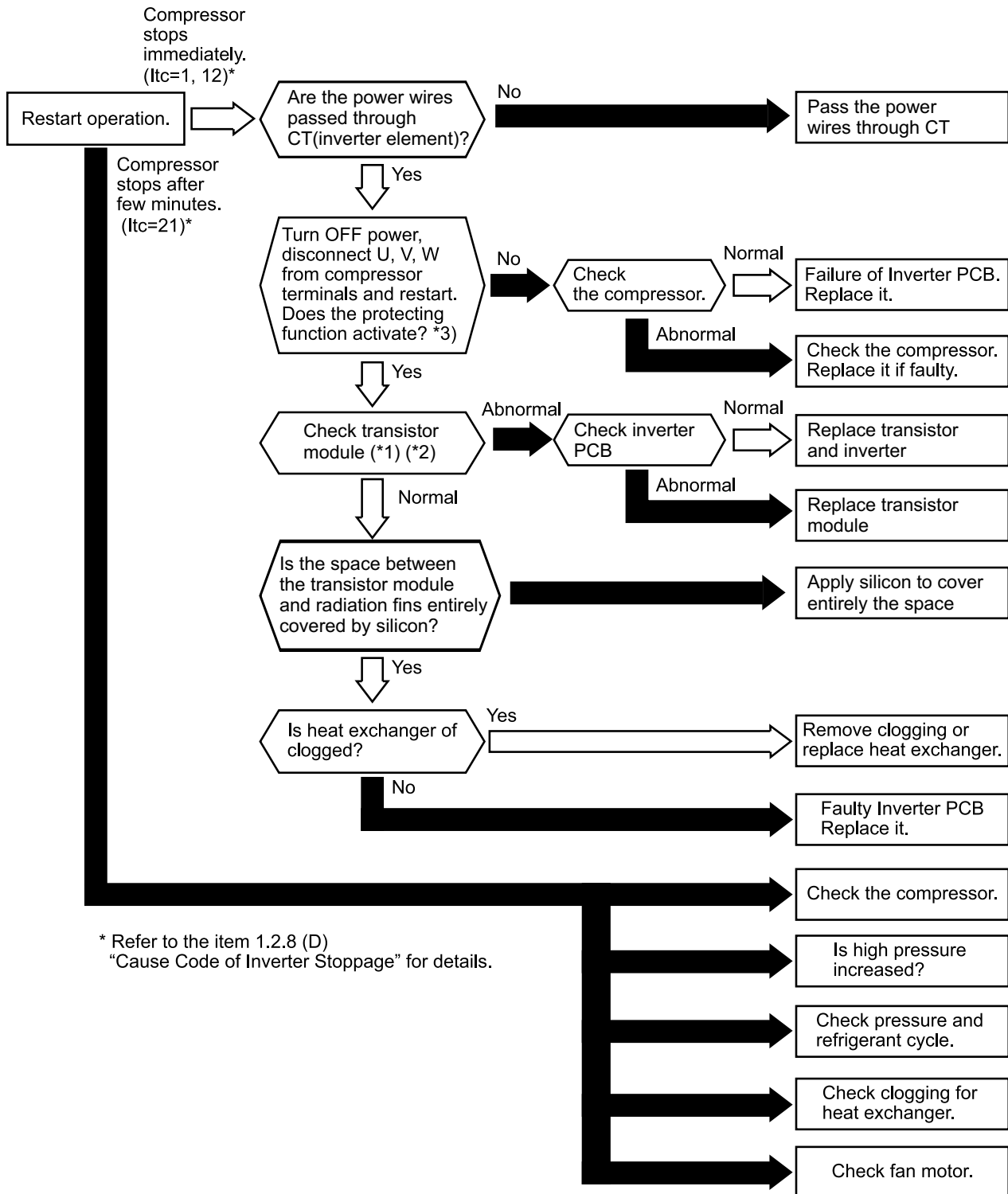

i NOTE

- *1) Perform the high voltage discharge work by referring to the item *Procedure of checking other main parts*, before checking and replacing the inverter components.
- *2) Regarding replacing or checking method for inverter components, refer to item *Procedure of checking other main parts*.
- *3) Turn ON the No.1 switch of the dip switch DSW1 on PCB2 (inverter) when restarting with disconnecting the terminals of the compressor. After troubleshooting, turn OFF the No.1 switch of the dip switch DSW1 on PCB2.
- When the alarm code "53" is indicated, the outdoor fan motor (DC motor) ensure that DC fan motor is checked according to the item *Procedure of checking other main parts*.

Alarm code

54

Abnormality of inverter fin temperature (RAS-3HVNPE / RAS-(4-6)H(V)N(P/C)E)

- The RUN LED flickers and “ALARM” is displayed on the remote control switch.
- The unit number, the alarm code and the unit code are alternately displayed on the set temperature section. The unit number and the alarm code are displayed on the display of the outdoor unit PCB.
 - This alarm code is indicated after the operation is stopped when the following condition occurs three times within 30 minutes. The retry operation is performed twice.

Conditions:

- When the temperature of the thermistor for inverter fin excess 80 °C (RAS-3HVNPE)
- When the temperature inside the transistor module excess 90 °C (RAS-(4-6)H(V)NPE).
- When the temperature of the thermistor for inverter fin excess 92 °C (RAS-(4-6)H(V)NCE)

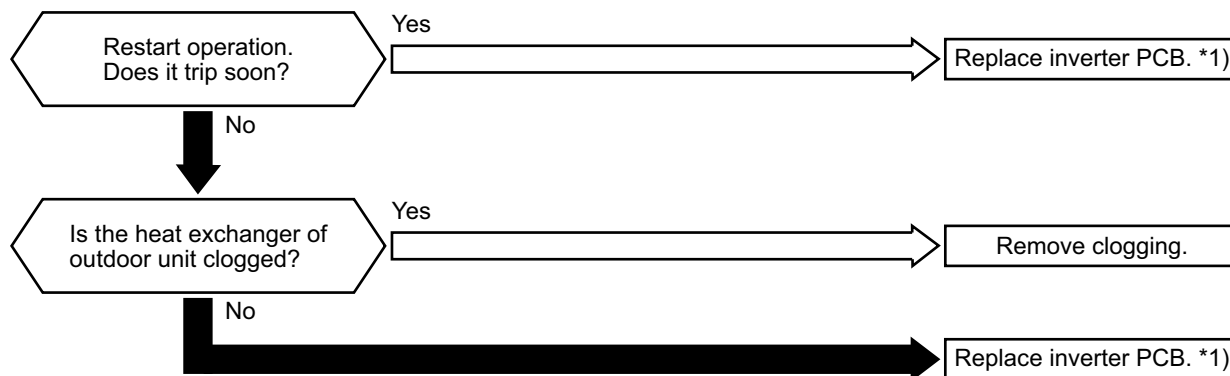
**NOTE**

1*): Perform the high voltage discharge work by referring to the item [Procedure of checking other main parts](#), before checking and replacing the inverter components.

Alarm code

54

Abnormality of inverter fin temperature (RAS-(8-12)HN(P/C)(E))

- The RUN LED flickers and “ALARM” is displayed on the remote control switch.
- The unit number, the alarm code and the unit code are alternately displayed on the set temperature section. The unit number and the alarm code are displayed on the display of the outdoor unit PCB.
 - This alarm code is indicated after the operation is stopped when the following condition occurs three times within 30 minutes. The retry operation is performed twice.

Conditions:

- When the temperature of the thermistor for inverter fin excess 100 °C.

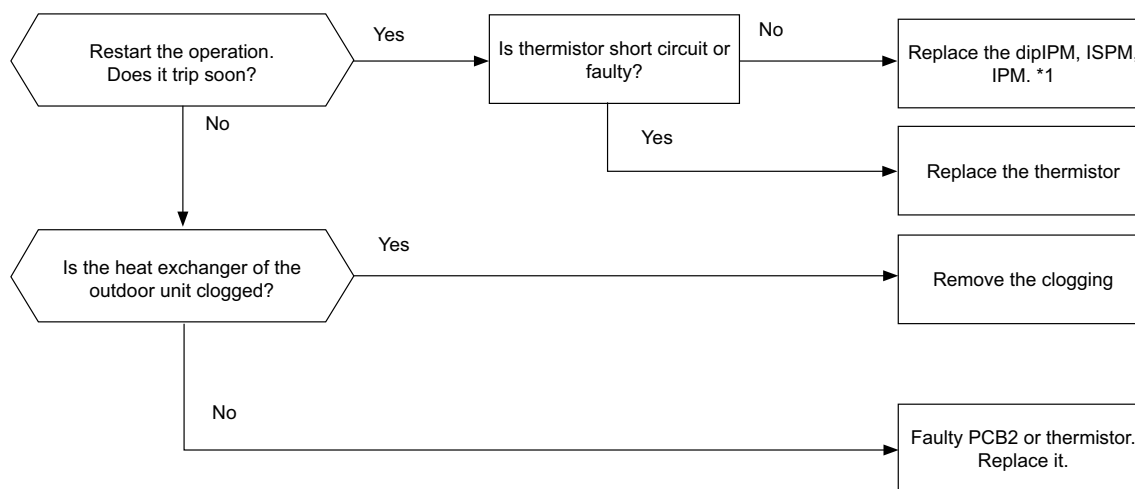
**NOTE**

1*): Perform the high voltage discharge work by referring to the item [Procedure of checking other main parts](#), before checking and replacing the inverter components.

Alarm code

55

Abnormality of Inverter Module

- The RUN LED flickers and “ALARM” is displayed on the remote control switch.
- The unit number, the alarm code and the unit code are alternately displayed on the set temperature section. The unit number and the alarm code are displayed on the display of the outdoor unit PCB.
 - Actual frequency from Inverter PCB is less than 10 Hz (after inverter frequency output form PCB1 to Inverter PCB).
 - This alarm is displayed when it occurs 3 times in 30 minutes. Retry operation is performed up to the occurrence of 2 times.

Condition of Activation:

This alarm is indicated when Inverter PCB is not performed normally.

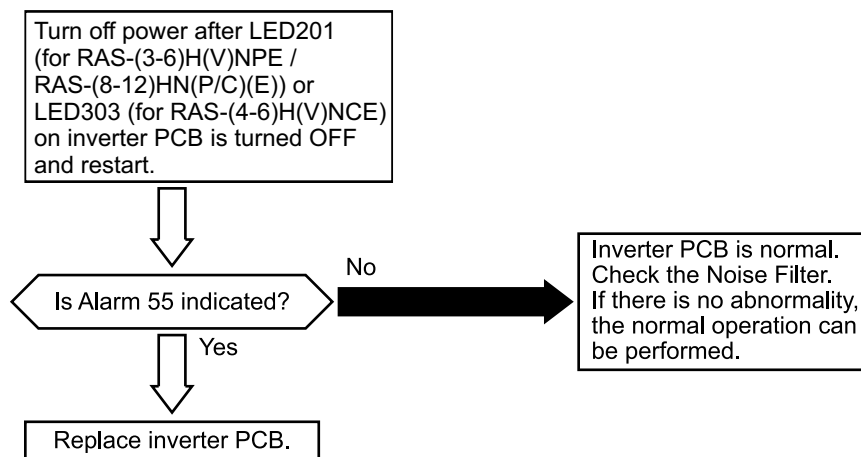
 **NOTE**

When the excessive surge current is applied to the unit due to lighting or other causes, this alarm code or the cause code of inverter stoppage (Itc=11) will be indicated on the 7-segment display on O.U. PCB1 and the unit can not be operated. In this case, check to ensure the surge absorber (SA) on the noise filter (NF1). The surge absorber may be damaged if the inner surface of the surge absorber is changed to black. If the surge absorber is damaged, replace the noise filter. If the surge absorber does not have abnormality, turn OFF the power source once and wait until turning OFF LED201 (red) on inverter PCB for approx. 5 min. Then, turn ON again.

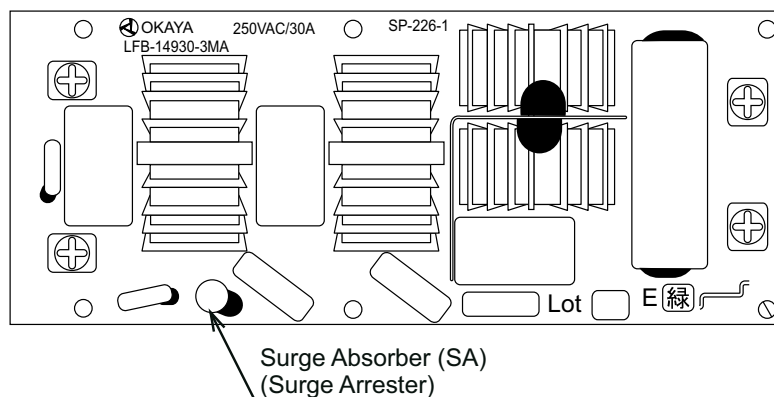

Alarm code

57

Abnormality of fan motor protection (DC fan motor) for RAS-(2-2.5)HVNP and RAS-3HVNC

- The RUN LED flickers and “ALARM” is displayed on the remote control switch.
- The unit number, the alarm code and the unit code are alternately displayed on the set temperature section. The unit number and the alarm code are displayed on the display of the outdoor unit PCB.
 - This alarm is indicated when the revolution pulse output from the fan motor is lower than 20min^{-1} during 30 seconds and it stops. Regarding stops, when less than 35 seconds have passed since fan start up, after the first abnormality is detected, if it occurs 4 times more within 5 minutes, it stops and alarm is displayed..

Alarm code

57

Abnormality of fan motor protection (DC fan motor)
for RAS-(3-6)H(V)NPE and RAS-(8-12)HN(P/C)(E)

- The RUN LED flickers and “ALARM” is displayed on the remote control switch.
- The unit number, the alarm code and the unit code are alternately displayed on the set temperature section. The unit number and the alarm code are displayed on the display of the outdoor unit PCB.
 - This alarm is indicated when the revolution pulse output from the fan motor is 10 rpm or less and the reverse revolution signal is detected. The fan motor is stopped once, and restarted after 10 seconds. If it occurs more than 10 times in 5 minutes after the first abnormality occurs, this alarm is indicated. The abnormality occurs when the fan motor is stopped by slugging.

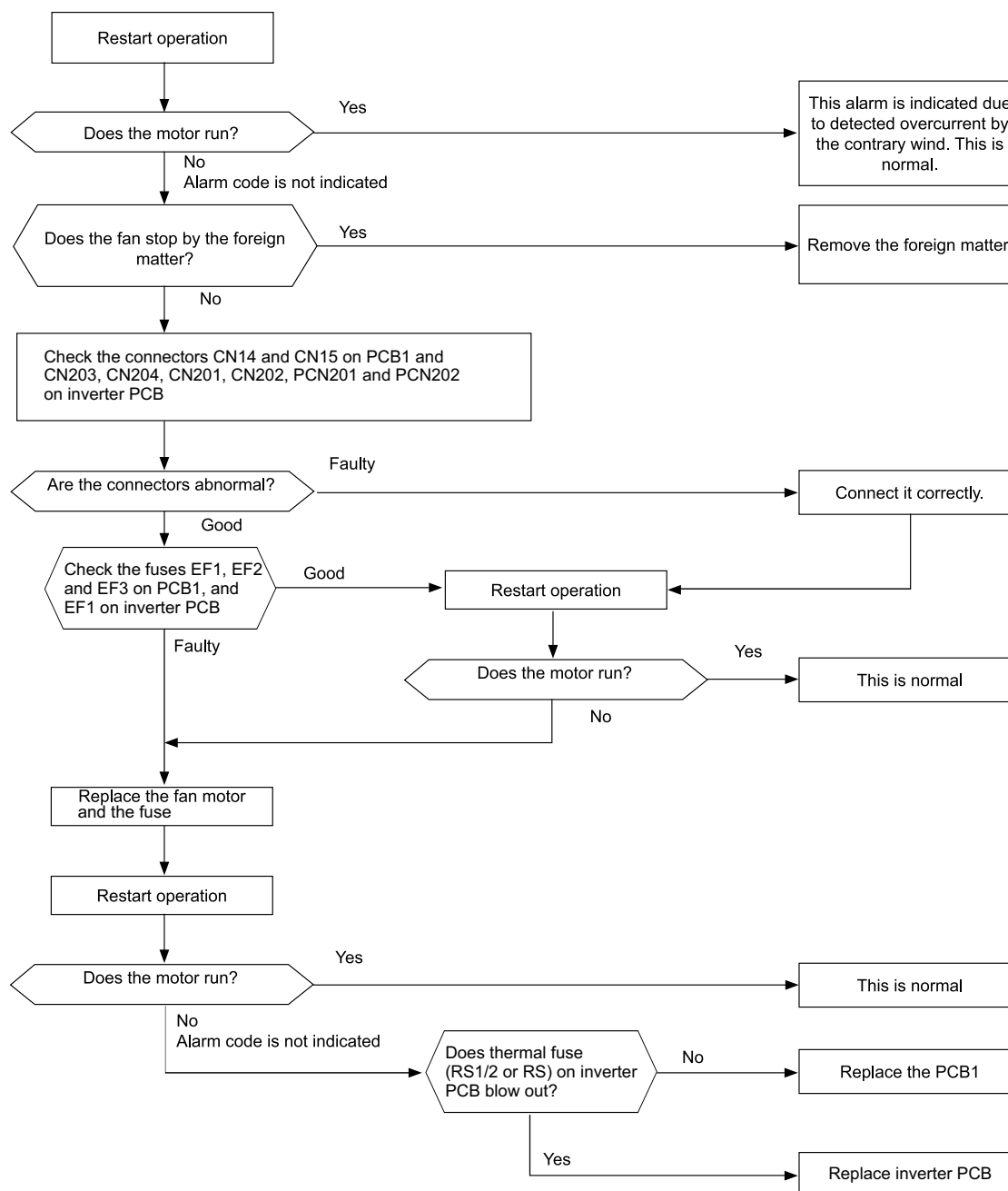

i NOTE

Check to ensure that DC Fan Motor is checked according to the item *Procedure of checking other main parts*.

Alarm code

57

Abnormality of fan motor protection (DC fan motor) for RAS-(4-6)H(V)NCE

- The RUN LED flickers and “ALARM” is displayed on the remote control switch.
- The unit number, the alarm code and the unit code are alternately displayed on the set temperature section. The unit number and the alarm code are displayed on the display of the outdoor unit PCB.
 - This alarm is indicated when the revolution pulse output from the fan motor is 10 rpm or less and the reverse revolution signal is detected. The fan motor is stopped once, and restarted after 10 seconds. If it occurs more than 10 times in 5 minutes after the first abnormality occurs, this alarm is indicated. The abnormality occurs when the fan motor is stopped by slugging.

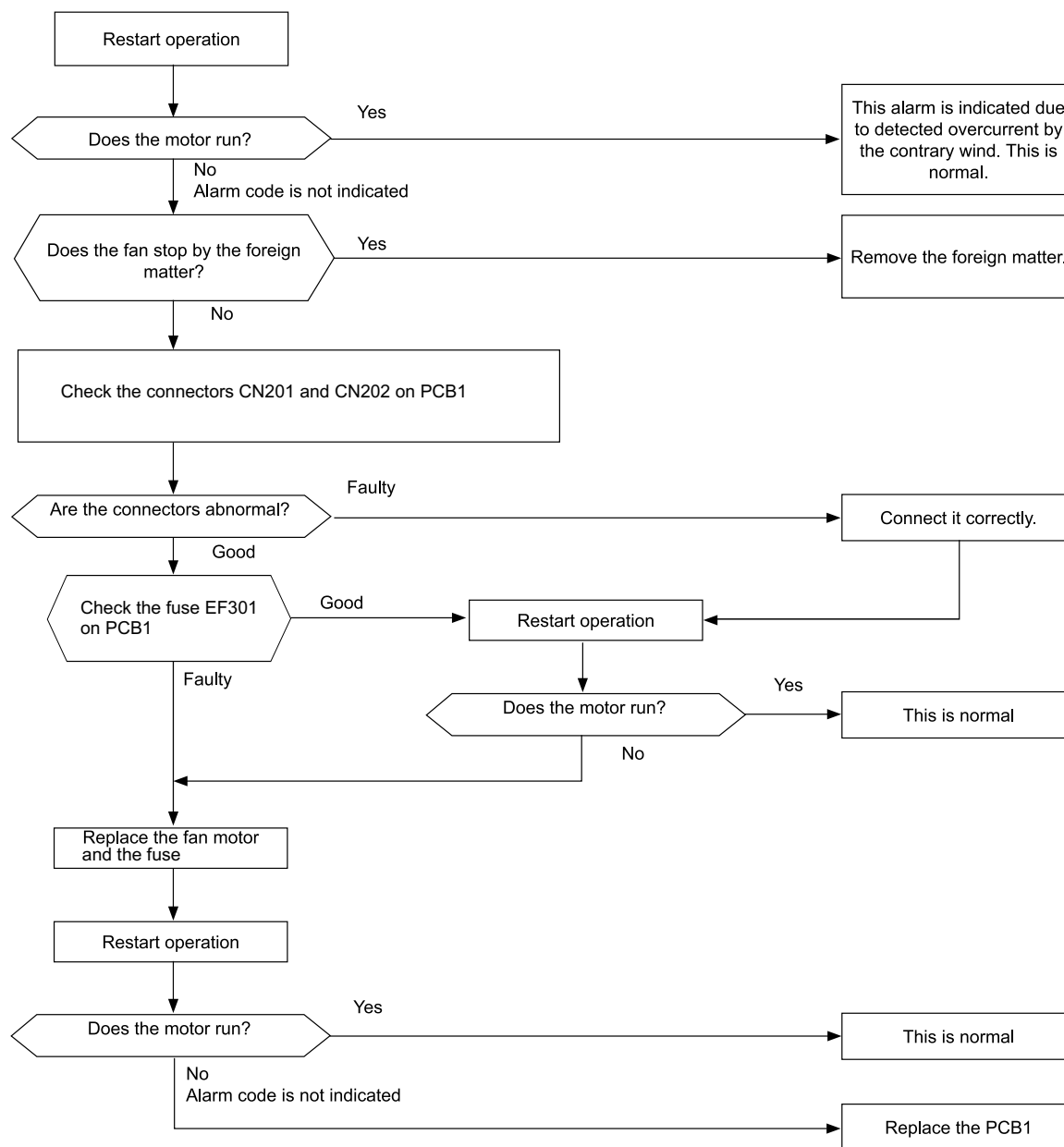
**NOTE**

Check to ensure that DC Fan Motor is checked according to the item [Procedure of checking other main parts](#).

Alarm code

EE

Compressor protection

- This alarm code is displayed when one of the following alarms occurs three times within six hours. If the outdoor unit operates continuously without removing the cause of the alarm, the compressor may be seriously damaged

Alarm code	Content of abnormality
02	Tripping of protection device in outdoor unit
07	Decrease in discharge gas superheat
08	Increase in discharge gas temperature
45	Activation of high pressure increase protection device
47	Low pressure decrease protection activating

You can check these alarms using the check mode 1. Follow the action that is indicated in each alarm chart. You can clear these alarms only by turning OFF the main switch to the system. **However, you must pay careful attention before starting, because there is a possibility of causing serious damages to the compressors.**

Alarm code

b0

Incorrect Setting of Unit Model Code

- The RUN LED flickers and "ALARM" is displayed on the remote control switch.
- The unit number, the alarm code and the unit code are alternately displayed on the set temperature section. The unit number and the alarm code are displayed on the display of the outdoor unit PCB.
 - This alarm code is indicated in the following condition. Check the unit model code setting (DSW4) of I.U. PCB after turning OFF the power source.

Condition	Action
The unit model code setting (DSW4) is not set (all pins are "OFF"), or is set for the incorrect indoor unit type.	Set DSW4 correctly according to the dip switch setting in "Installation and Maintenance Manual".

Alarm code

b1

Incorrect Setting of Unit and Refrigerant Cycle No.

- The RUN LED flickers and “ALARM” is displayed on the remote control switch.
- The unit number, the alarm code and the unit code are alternately displayed on the set temperature section. The unit number and the alarm code are displayed on the display of the outdoor unit PCB.
 - This alarm code is indicated in the following condition. Check the settings of the dip switch (DSW) and the rotary switch (RSW) after turning OFF the power source.

Conditions	Action
The unit No. setting (DSW6 and RSW1) or the refrigerant cycle No. setting (DSW5 and RSW2) is set as “64” or more, or more than 2 pins of DSW5 or DSW6 are set.	a) Unit No. Setting / Ref. Cycle No. Setting Starting <ul style="list-style-type: none"> - from “1” (recommended) - Set the unit No. and the refrigerant cycle No. - from “1” to “63”. (Setting No. for the 64th unit shall be “0”.) b) Unit No. Setting / Ref. Cycle No. Setting Starting <ul style="list-style-type: none"> - from “0” - Set the unit No. and the refrigerant cycle No. - from “0” to “63.” (Setting No. for the 64th unit shall be “63”.)
The unit No. setting and the refrigerant cycle No. setting are set between “16” and “63,” and the indoor unit does not support H-LINK II.	Set the unit No. and the refrigerant cycle No. between “0” and “15.”

Alarm code

b5

Incorrect Setting of Indoor Unit Number for H-LINK Type

- The RUN LED flickers and “ALARM” is displayed on the remote control switch.
- The unit number, the alarm code*) and the unit code are alternately displayed on the set temperature section. The unit number and the alarm code are displayed on the display of the outdoor unit PCB.

*) The alarm code indicated on the remote control switch is “35”.

Condition	Action
The number of the connected indoor units not supporting H-LINK II is 17 and after.	The number of the connected indoor units shall be 16 and before.

8

8.2.4 Alarm codes for the KPI (E/H/X)3E Series and DX Interface

Code No.	DX-KIT2	KPI-S3	KPI-Active	Category	Type of Abnormality	Main cause
01	o	-	o	Indoor	Activation of protection device	Float switch activation (high water level in drain hose or abnormality in drain pipe, float switch or drain pan).
03	o	-	o	Transmission	Transmission Error	Outdoor fuse meltdown, Indoor/outdoor connection wiring (breaking, wiring error, etc.)
11	o	o	o	Indoor	Air inlet thermistor (RA for KPI)	Loose, disconnected, broken or short-circuited connector
12	o	o	o	Indoor	Air outlet thermistor (OA for KPI)	Loose, disconnected, broken or short-circuited connector
13	o	-	o	Indoor	Liquid pipe thermistor	Loose, disconnected, broken or short-circuited connector
14	o	-	o	Indoor	Gas pipe thermistor	Loose, disconnected, broken or short-circuited connector
15	-	-	-	Indoor	Fresh Outdoor Air Thermistor (Econofresh)	Loose, disconnected, broken or short-circuited connector
16	-	-	o	Indoor	Air inlet DX Coil thermistor (Tincoil)	Loose, disconnected, broken or short-circuited connector
17	-	-	o	Indoor	Air outlet DX Coil thermistor (Toutcoil)	Loose, disconnected, broken or short-circuited connector
18	(o)	o	o	Indoor	Indoor RA fan protection device activation for KP	Fan motor overheating, locking.
19	o	o	o	Indoor	Indoor OA fan protection device activation for KPI or DX-KIT2 Fan	Fan motor overheating, locking.,
31	o	-	o	System	Incorrect setting of outdoor and indoor units	Outdoor/Indoor Unit capacity setting error, Indoor total capacity excessively large/small
35	o	-	o	System	Indoor Unit Number Setting Error	Indoor units with the same number exist in a refrigerant piping system
70	o	o	o	Indoor	Abnormal transmission between PCB1 and PCB2	Loose, disconnected
71	o	o	o	Indoor	Incorrect PCBs setting	Wrong setting are performed in PCBs
EE	o	-	o	Compressor	Compressor protection alarm (cannot be reset from the remote controller)	This alarm code is displayed when the following alarms are triggered three times within six hours: 02,07,08,39,43 to 45, 47
74	-	-	-	Indoor	Remote sensor thermistor (Trem)	Loose, disconnected, broken or short-circuited connector

8.3 Troubleshooting in check mode

8.3.1 Troubleshooting using the remote controller PC-ART

Use the "OK" switch of the remote control in the following cases:

- 1 When the RUN LED is flickering.
- 2 To trace back the cause of the malfunction after restarting from the stoppage while the RUN LED is flickering.
- 3 To check during the normal operation or during the stoppage.
- 4 To monitor the inlet air temperature and the discharge air temperature.

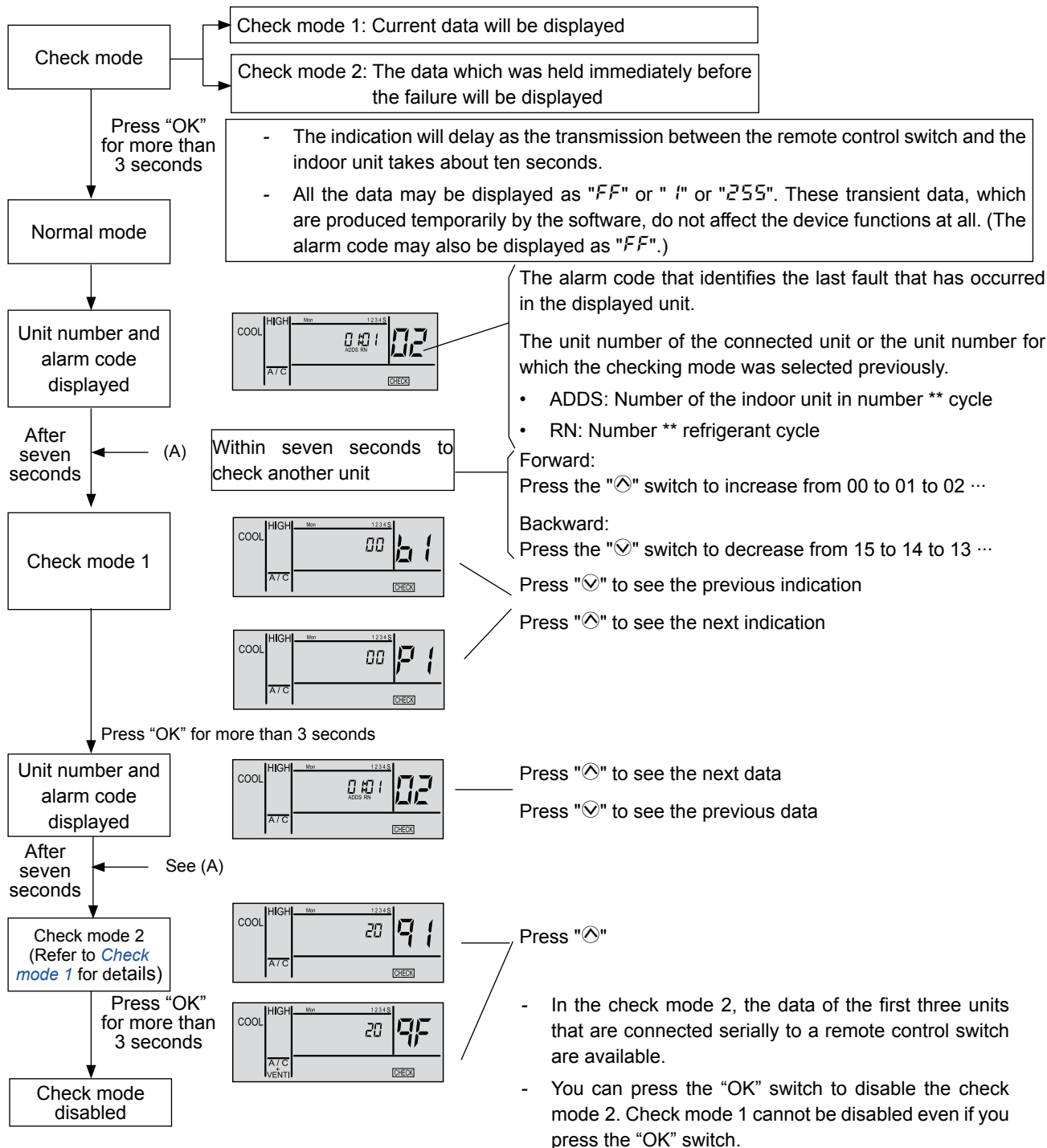
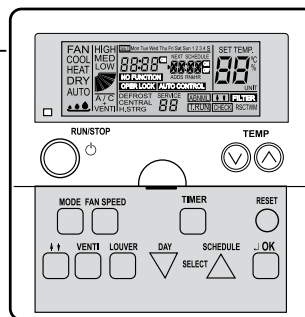

Although the wireless controller is used for the wall type indoor unit with the built-in receiver part, you can check the alarm code by connecting the PC-P2HTE.

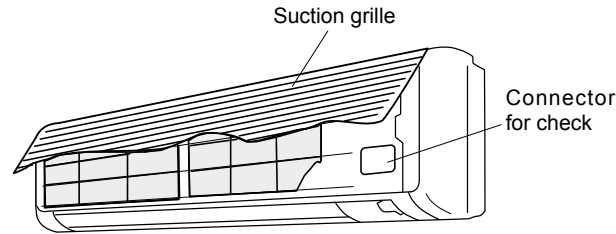

NOTE

- **The unit does not operate by pressing the operation switch.**
- **The above function is available only when the alarm occurs.**
- **The PCB check using the remote control switch is not available.**
- **The indication is the data when you are connecting PC-P2HTE. The indication is not the data before the alarm occurs.**

◆ Contents of the check mode 1

The next indication is shown if you press the part “△” of the TEMP switch. If you press the part “▽” of the TEMP switch, the previous indication is shown.

Temperature indication

		Indication of the category code	Indication of the temperature, etc
1	Indoor unit temperature setting (°C)		61 22
2	Indoor unit air inlet temperature at thermistor (°C)	Normal	62 20
3	Indoor unit discharge air temperature at thermistor (°C)	Abnormal	-- (Thermistor is open-circuited or PCB is defective)
4	Indoor unit heat exchanger liquid pipe temperature (°C)		or 129 (Temperature for top of compressor)
5	Temperature at remote sensor (°C)		or FF (Thermistor is short-circuited or PCB is defective)
6	Outdoor unit ambient temperature (°C)		or 255 (Temperature for top of compressor)
7	Indoor unit heat exchanger gas pipe temperature (°C)		67 25
8	Outdoor unit evaporating temperature during heating (°C)		68 02
9	Control information		69 --
10	Discharge gas temperature at the top of the compressor chamber (°C)		6A 41
11	Thermo temperature of the remote control switch		6b 23

Refer to section [Self-checking procedure of PCB using the remote control switch](#)



During the transient periods such as starting time and other, the indicators “--” or “00” may be displayed for a limited time.

This is indicated only when a remote sensor is connected. The indicator “--” is normally displayed. RPK series cannot connect a remote sensor. Therefore, the indicator is “--”.

This indicates the internal information for the remote control switch. This does not have any specific meaning.



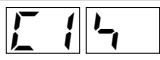



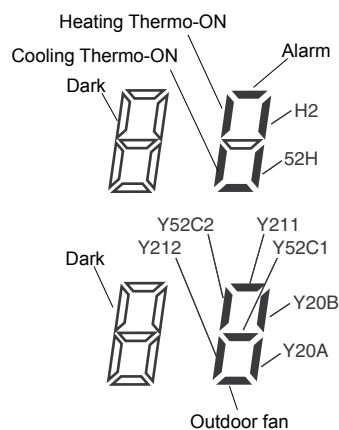

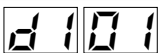









(Ex.) During the operation of several compressors, the average temperature of two compressors is indicated. If the temperature is higher than 126 °C, “126”

Indication of micro-computer input/output

12	Micro-computer input/output in indoor unit	
13	Micro-computer input/output in outdoor unit	

**Indication of unit stoppage cause**

14	Cause of stoppage	
----	-------------------	---

	Operation OFF, power OFF
	Thermo - OFF (NOTE 1), activating float switch
	Alarm (NOTE 2)
	Freeze protection, overheating protection
	Instantaneous power failure at outdoor unit, reset (NOTE 3)
	Instantaneous power failure at indoor unit, reset (NOTE 4)
	Outdoor temperature at cooling lower than -5°C, outdoor air temperature and indoor suction temperature at heating (Overload condition), outdoor temperature at heating lower than -20°C.
	Demand, emergency stoppage (DSW 1-4 ON or forced stop)
	Retry due to compression ratio decrease
	Retry due to low pressure increase
	Retry due to high pressure increase
	Retry due to abnormal high temperature of discharge gas, excessive low suction pressure
	Retry due to decrease of discharge gas superheat
	Retry due to inverter tripping (Instantaneous overcurrent, electronic thermal activation, current sensor abnormality)
	Retry due to inverter tripping (Inverter undervoltage, overvoltage, transmission error, microcomputer reset, etc.)
	Expansion valve opening change protection
	Thermo OFF due to oil return control
	Outdoor unit hot start control

**NOTE 1****Explanation of term,**

Thermo-ON: A condition that an indoor unit is requesting compressor to operate.

Thermo-OFF: A condition that an indoor unit is not requesting compressor to operate.

**NOTE 2**

Even if stoppage is caused by "Alarm", "02" is not always indicated.

**NOTE 3**

If transmission between the inverter printed circuit board and the control printed circuit board is not performed during 30 seconds, the outdoor unit is stopped.

In this case, stoppage is d1-05 cause and the alarm code "04" may be indicated.

**NOTE 4**

If transmission between the indoor unit and the outdoor unit is not performed during 3 minutes, indoor units are stopped.

In this case, stoppage is d1-06 cause and the alarm code "03" may be indicated.

Abnormal operation occurrence counter

15	Abnormal operation occurrence counter	E101
16	Instantaneous power failure occurrence counter in indoor unit	E200
17	Transmission error occurrence counter between remote control switch and indoor unit	E300
18	Abnormal operation occurrence counter on inverter	E400

Countable up to 99.

Over 99 times, "99" is always displayed.

**NOTE**

- *If a transmission error continues for three minutes, one is added to the occurrence counter.*
- *The memorized data can be cancelled by the method which is explained in section [Self-checking procedure of PCB using the remote control switch](#).*

Indication of automatic louver condition

19	Louver sensor	F100
----	---------------	------

00 : Normal

FF : Abnormal

Compressor pressure/frequency indication

20	Discharge pressure (high) (x 0.1 MPa)	H118
21	Suction pressure (low) (x 0.01 MPa)	H204
22	Control information	H344
23	Operation frequency (Hz)	H444

This is an indication for internal information for the remote control switch. This does not have any specific meaning

This is an indication for frequency of inverter

Indoor unit capacity indication

24	Indoor unit capacity	J108
----	----------------------	------

The capacity of the indoor unit is indicated as shown in the table below.

Capacity code of indoor unit

Indication code	Equivalent capacity (HP)
06	0.8
08	1.0
10	1.3
13	1.5
14	1.8
16	2.0
18	2.3
20	2.5
22	2.8
26	3.0
32	4.0
40	5.0
48	6.0
64	8.0
80	10.0

"n" indicates the total number of Indoor Units:

1-9 A b c d E F U
1-9 10 11 12 13 14 15 16

J3: 01 ~ 64 (Decimal code)

J4: 00 ~ 3F (Hexadecimal code)

Expansion opening indication

28	Indoor unit expansion valve opening (%)	L120
29	Outdoor unit expansion valve MV1 opening (%)	L299
30	Outdoor unit expansion valve MV2 opening (%)	L399
31	Control information	L400

In case of models without the expansion valve (MV2), the same figure is displayed

Estimated electric current indication

32	Compressor running current (A)	P125
----	--------------------------------	------



The total current is displayed when several compressors are running.

In case of the inverter compressor, the running current of the primary side of the inverter is displayed.

☛ Returns to **temperature indication**

◆ Contents of the check mode 2

When more than three indoor units are connected to one remote control switch, the latest data of only the first three indoor units that are connected serially are displayed.

If you press the part “” of the TEMP switch, the next display appears. If you press the part “” of the TEMP switch, the previous display appears.

Temperature indication

			Indication of the category code
			Indication of the temperature, etc
1	Indoor unit air inlet temperature at thermistor (°C)	91.23	Corresponds to check mode 1 “b2”
2	Indoor unit discharge air temperature at thermistor (°C)	92.50	Corresponds to check mode 1 “b3”
3	Indoor unit heat exchanger liquid pipe temperature (freeze protection) (°C)	93.25	Corresponds to check mode 1 “b4”
4	Outdoor temperature (°C)	94.12	Corresponds to check mode 1 “b5”
5	Indoor unit heat exchanger gas pipe temperature (°C)	95.25	Corresponds to check mode 1 “b7”
6	Evaporating temperature at heating (°C)	96.03	Corresponds to check mode 1 “b8”
7	Control information	97.--	Corresponds to check mode 1 “b9”
8	Discharge gas temperature at the top of compressor chamber (°C)	98.45	Corresponds to check mode 1 “bR”

Compressor pressure/frequency indication

9	Discharge pressure (high) (x 0.1 MPa)	99.18	Corresponds to check mode 1 “H1”
10	Suction pressure (low) (x 0.01 MPa)	9A.04	Corresponds to check mode 1 “H2”
11	Control information	9B.44	Corresponds to check mode 1 “H3”
12	Operating frequency (Hz)	9C.44	Corresponds to check mode 1 “H4”

Expansion opening indication

13	Indoor unit expansion valve opening (%)	9d.20	Corresponds to check mode 1 “L1”
14	Outdoor unit expansion valve mv1 opening (%)	9E.99	Corresponds to check mode 1 “L2”

Estimated electric current indication

15	Compressor running current (A)	9F.20	Corresponds to check mode 1 “P1”
----	--------------------------------	-------	----------------------------------

● Returns to temperature indication

◆ Self-checking procedure of PCB by means of the Remote Control Switch

Use the following troubleshooting procedure for testing the PCB in the indoor unit and the outdoor unit:

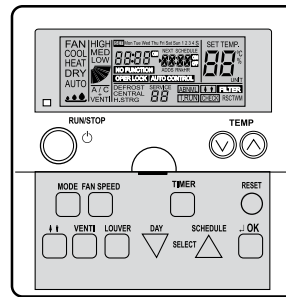
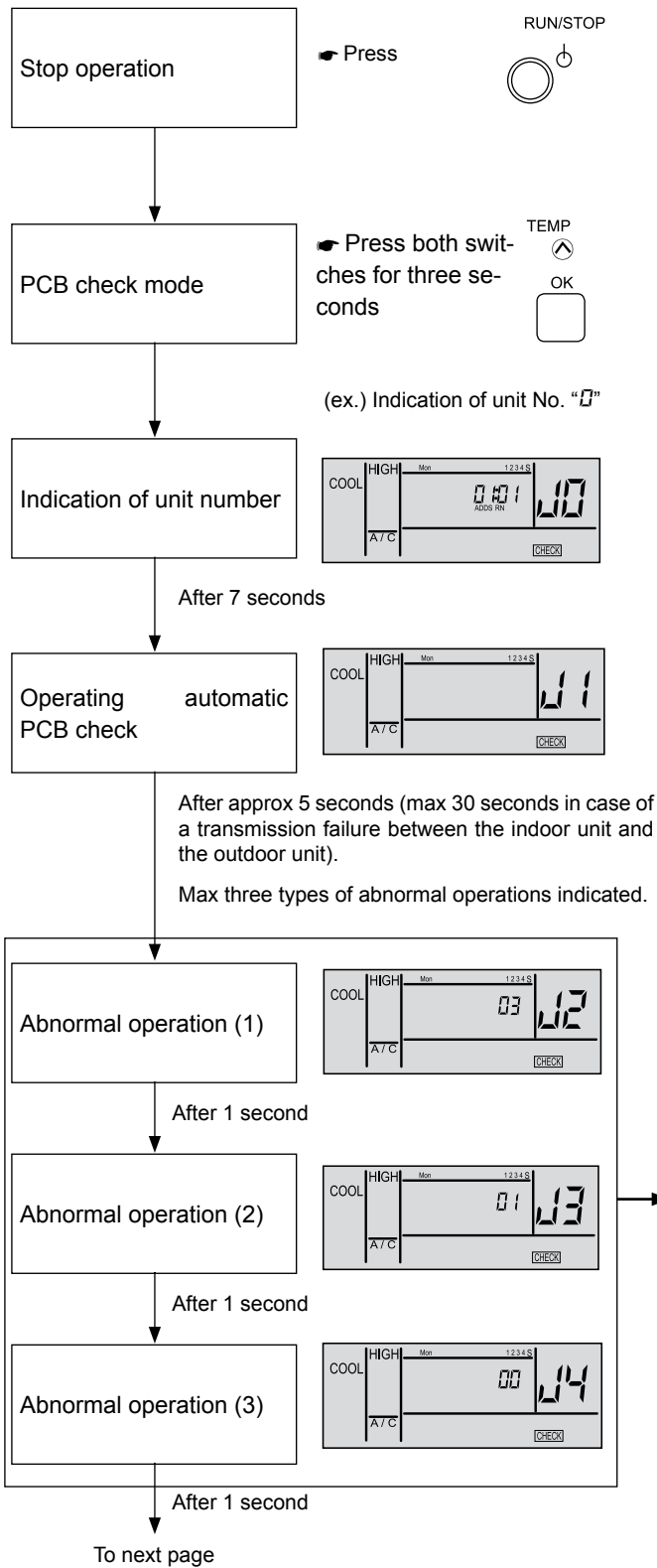

Indication	Contents	
00	Normal	
Abnormality (open-circuit, short-circuit, etc.) in circuit for:		
01	Air inlet temperature thermistor	Indoor unit PCB
02	Discharge air temperature thermistor	
03	Liquid pipe temperature thermistor	
04	Remote thermistor abnormality	
05	Gas pipe temperature thermistor	
06	Remote sensor	
08	Transmission of central station	
0A	EEPROM	
0b	Zero cross input failure	
EE	Transmission of indoor units during this checking operation	
07	Transmission of outdoor unit	Outdoor unit PCB
F4	Internal thermostat fan input failure	
F5	PSW input failure	
F6	PSH protection signal detection circuit	
F7	Phase detection	
F8	Transmission of inverter	
Fa	High-pressure sensor	
Fb	Compressor discharge gas temperature thermistor	
Fc	Low-pressure sensor	
Fd	Heat exchanger evaporation temperature thermistor	
FF	Ambient air temperature thermistor	

If you are using a wireless remote control switch with the built-in receiver part of the wall-type indoor unit and you need to perform the above checking, perform the following procedure:

- 1 Turn OFF the power supply.
- 2 Disconnect the connector (CN25) on PWB(M).
- 3 Connect the PC-ART.
- 4 Turn ON the power supply.

After finishing the checking, turn OFF the power supply again and reconnect the connectors according to the previous situation before the checking.

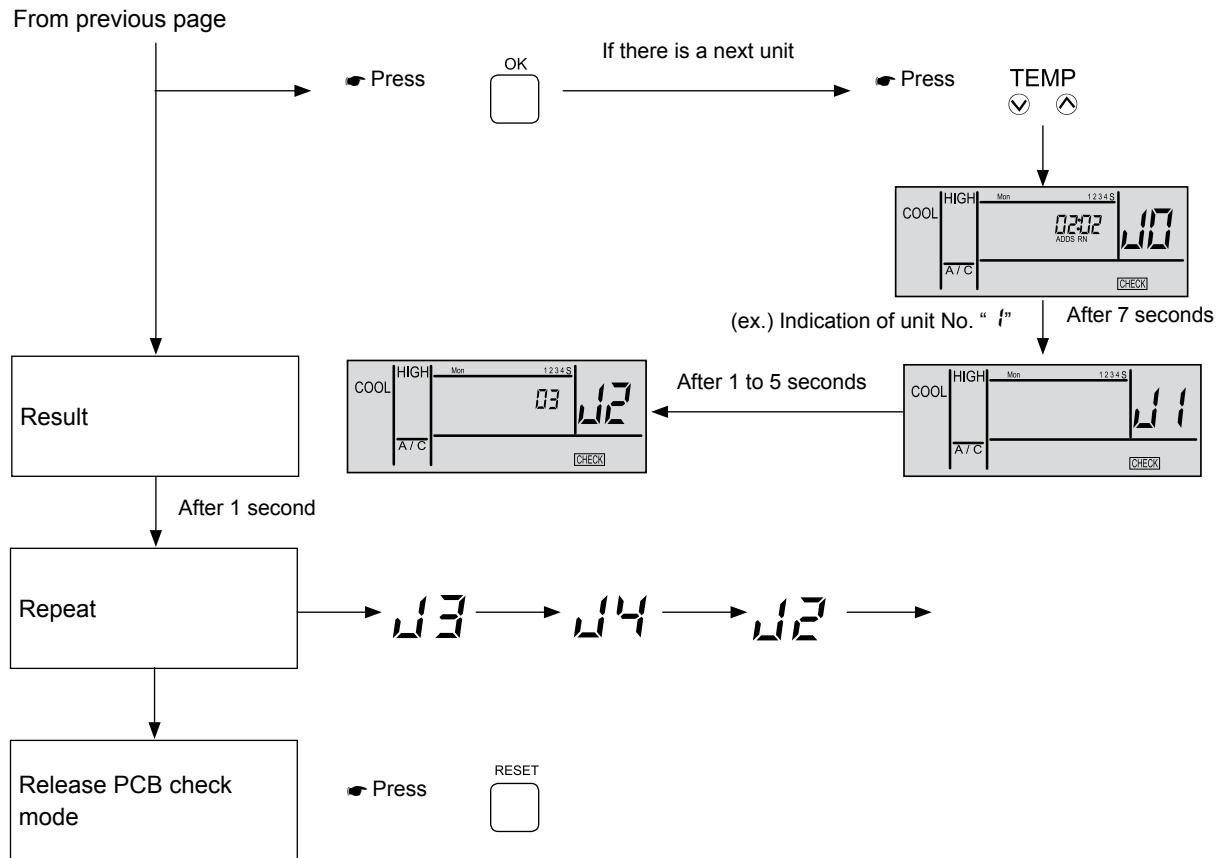

NOTE

- If this indication continues and the alarm code "11" is not displayed, this means that each one of indoor unit is not connected to the remote control switch. Check the wiring between the remote control switch and the indoor unit.

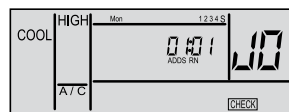

- In this troubleshooting procedure, checking of the following parts of the PCB is not available.
PCB in indoor unit: relay circuit, DIP switch, option circuit, fan circuit, protection circuit.
PCB in outdoor unit: relay circuit, DIP switch, option circuit.
- If this troubleshooting is performed in the system using the central station, the indication of the central station may change during this procedure. However, this is not abnormal.
- After this troubleshooting, the memory of the abnormal operation occurrence counter, which was described before, will be deleted.

◆ Self-checking procedure of the remote control switch

Cases where the OK switch is used:

- 1 If the remote control switch displays a malfunction.
- 2 For the regular maintenance check.

1 Turn ON the power source

2 Simultaneously press the following three switches. (During the operation, you can press the switches.)

TEMP MODE

⓪ ⓪

3 The LCD changes as shown in the right figure.

4 After the LCD changes as shown in the right figure, the RUN indicator flickers twice.

01

No.	LCD indication	Indicating period (sec.)
1		1
2		1
3		1
4		1
5		3

Only for the cancellation of EEPROM, press the following three switches simultaneously during the changes of the LCD.

TEMP MODE

⓪ ⓪

To
11

5 The LCD changes as shown below. Press all the switches (13 switches) one by one. Every time you press the switch, the number of the indication of the part (A) in the figure below increases one.

(A) → 02

i NOTE

- Unless all the switches are pressed, the checking does not proceed to the next item.
- You can press the switches in any order.
- Pressing two or more switches simultaneously is invalid and not counted.

6 The LCD changes as shown below. The remote control switch automatically starts to check the transmission circuit

03

i NOTE

In case that the transmission circuit is abnormal, the LCD remains as shown in the left figure and the checking does not proceed to the next item.

7

The LCD changes as shown below.

The detected temperature of the remote control thermostat is displayed at the (A) part in the figure below.

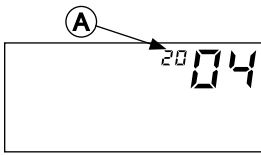

If the indicators "--" or "FF" are displayed at the "A" part, the remote control thermostat is abnormal.

8

The LCD changes as shown below.



If you press the RESET switch or you leave the switches for 15 seconds, the data of EEPROM (storage cell inside of the remote control switch) is cleared.

At this time, the number is displayed at the (A) part, which is shown in the figure below. When the number "99" is displayed, EEPROM is abnormal.

9

The LCD changes as shown below.



After several seconds have passed, the remote control switch is automatically activated again.

If the number which is displayed at the (A) part is "99", the checking does not proceed to the next item.

10

When the remote control switch is activated again, the RUN indicator is ON and the operation is started.

Therefore, press the RUN/STOP switch and stop the operation.



NOTE

- ***In case that the operation is not automatically started when the remote control switch is activated again, the detection circuit for the momentary stoppage may be abnormal. However, the detection circuit will not interfere with the normal operation.***
- ***There is a case where the operation is automatically stopped after the automatic operation when the remote control switch is activated again.***

Cancellation of EEPROM
(from step 3)

11

The LCD changes as shown below and the remote control switch automatically cancels the EEPROM.



12

The LCD changes as shown below



After several seconds have passed, the remote control switch is automatically activated again. In this case, the operation is not started automatically.

8.3.2 Troubleshooting using the remote controller PC-ARF

Each “Check Menu” item and its function are explained in the following table.

Check Menu Item	Function
Check 1	Sensor condition of air conditioner will be monitored and indicated.
Check 2	Sensor data of air conditioner prior to alarm occurrence will be indicated.
Alarm History Display	Previous alarm record (date, time, alarm code) will be indicated.
Model Display	Model name and manufacturing number will be indicated.
I.U./O.U. PCB Check	The result of PCB check will be indicated.
Self Checking	Checking of remote control switch will be carried out.

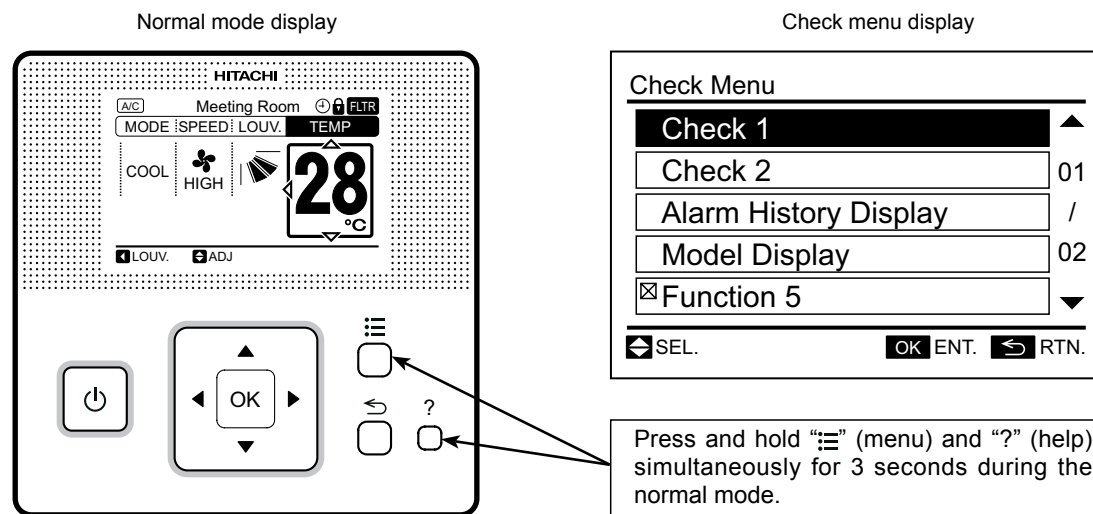

◆ Contents of the check mode 1 and 2

(1) Press and hold “≡” (menu) and “?” (help) simultaneously for 3 seconds during the normal mode. The check menu is displayed.

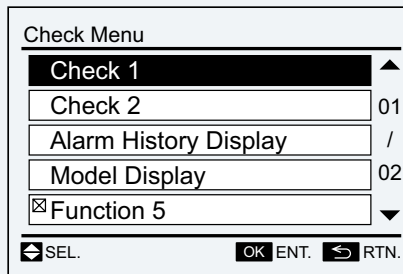

(2) Select “Check 1” (or “Check 2”) from the check menu and press “OK”.

(3) Select the set indoor unit by pressing “Δ ∇ < ▷” and press “OK”. (This screen is NOT displayed when the number of indoor units connected with the remote control switch is 1 (one). In this case, (4) will be displayed.)

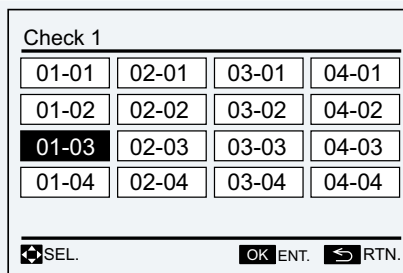

(4) Press “Δ” or “∇” to change the screen.

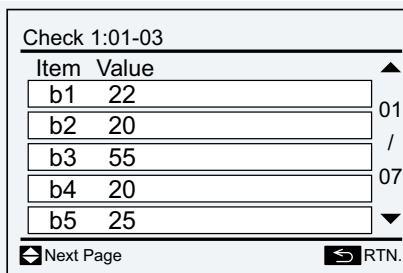

Check mode 1 items

No.	Item	Data Name	No.	Item	Data Name
1	b1	Set Temp.	18	E3	Times of Abnormal Transmitting
2	b2	Inlet Air Temp.	19	E4	Times of Inverter Tripping
3	b3	Discharge Air Temp.	20	F1	Louver Sensor State
4	b4	Liquid Pipe Temp.	21	H1	Discharge Pressure
5	b5	Remote Thermistor Temp.	22	H2	Suction Pressure
6	b6	Outdoor Air Temp.	23	H3	Control Information
7	b7	Gas Pipe Temp.	24	H4	Operating Frequency
8	b8	Evaporating Temp. at Heating	25	J1	I.U. Capacity
9	b9	Condensing Temp. at Cooling	26	J2	O.U. Code
10	bA	Comp. Top Temp.	27	J3	Refrigerant Cycle Number (1)
11	bb	Thermo Temp. of Remote Control Switch	28	J4	Refrigerant Cycle Number (2)
12	bC	Not Prepared	29	L1	I.U. Expansion Valve
13	C1	I.U. Micro-Computer	30	L2	O.U. Expansion Valve 1
14	C2	O.U. Micro-Computer	31	L3	O.U. Expansion Valve 2
15	d1	Stopping Cause State Indication	32	L4	O.U. Expansion Valve B
16	E1	Times of Abnormality	33	P1	Comp. Current
17	E2	Times of Power Failure	34	q1	Motion Sensor Reaction Rate (0 ~ 100%)

Check mode 2 items

No.	Item	Data Name	No.	Item	Data Name
1	q1	Inlet Air Temp.	9	q9	Discharge Pressure
2	q2	Discharge Air Temp.	10	qA	Suction Pressure
3	q3	Liquid Pipe Temp.	11	qb	Control Information
4	q4	Outdoor Air Temp.	12	qC	Operating Frequency
5	q5	Gas Pipe Temp.	13	qd	I.U. Expansion Valve
6	q6	Evaporating Temp. at Heating	14	qE	O.U. Expansion Valve 1
7	q7	Condensing Temp. at Cooling	15	qF	Comp. Current
8	q8	Comp. Top Temp.			

◆ Checking procedure of PCB by means of the Remote Control Switch

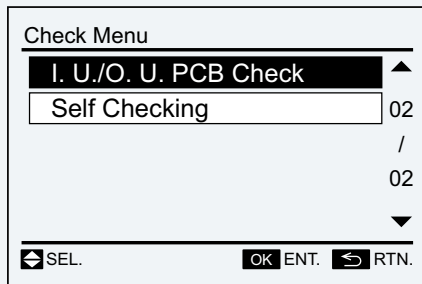
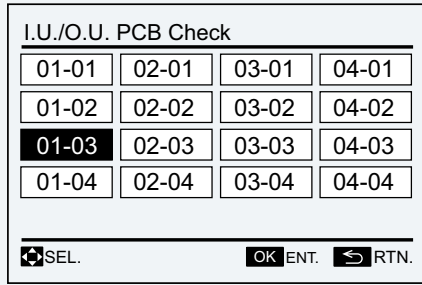
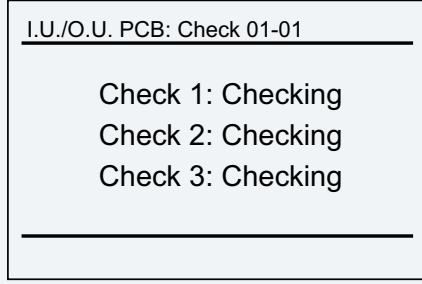
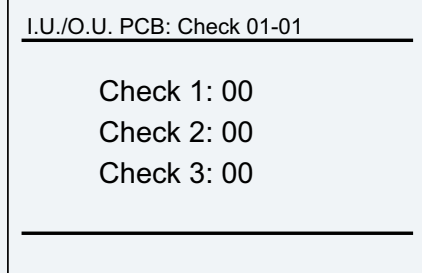
<p>(1) Press and hold “☰” (menu) and “?” (help) simultaneously for 3 seconds during the normal mode. The check menu is displayed.</p>	
<p>(2) Select “I.U./O.U. PCB Check” from the check menu and press “OK”.</p>	
<p>(3) Select the set indoor unit by pressing “△ ▽ ◀ ▶” and press “OK”. (This screen is NOT displayed when the number of indoor units connected with the remote control switch is 1 (one). In this case, (4) will be displayed.)</p>	
<p>(4) The indoor unit PCB and the outdoor unit PCB checks are started.</p> <p>* If “☰” (menu) is pressed during the check, the check is canceled and the screen will return to (2).</p> <p>* If “↵” (return) is pressed during the check, the check is canceled and the screen will return to (3).</p>	
<p>(5) After completing the check, the result of PCB check will be indicated. Press “↵” (return) and return to (3).</p>	

Result of check table

Indoor Unit PCB	Outdoor Unit PCB
□□ Normal	□□ Normal
□1 Abnormality of Inlet Air Temp. Thermistor	□7 Abnormality of Transmission of Outdoor Unit
□2 Abnormality of Outlet Air Temp. Thermistor	F4 ITO Input Failure
□3 Abnormality of Liquid Pipe Temp. Thermistor	F5 PSH Input Failure
□4 Abnormality of Remote Thermistor	F6 Abnormality of Protection Signal Detection Circuit
□5 Abnormality of Gas Pipe Temp. Thermistor	F7 Abnormality of Phase Detection
□1 Abnormality of Transmission of Central Station	F8 Abnormality of Transmission of Inverter
□B Abnormality of EEPROM	FR Abnormality of High Pressure Sensor
□R Zero Cross Input Failure	Fb Abnormality of Comp. Discharge Gas Temp. Thermistor
□b Abnormality of Transmission of I.U. during Check	Fc Abnormality of Low Pressure Sensor
	Fd Abnormality of Evaporating Temp. Thermistor at Heating
	Ff Abnormality of Ambient Air Temp. Thermistor

◆ Self-checking procedure of PCB by means of the Remote Control Switch

The self checking performs to check the remote control switch and to clear EEPROM (storage cell inside of the remote control switch).

(1) Press and hold "☰" (menu) and "?" (help) simultaneously for 3 seconds during the normal mode (when unit is not operated).

The check menu is displayed.

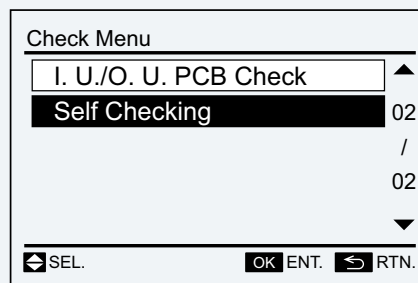

(2) Select "Self Checking" from the check menu and press "OK".

(3) Select the process for "Self Checking".

*To start self check, press "?" (help).

*To clear EEPROM, press "√" and "?" (help) simultaneously.

→ See EEPROM clear process (15) (next page).

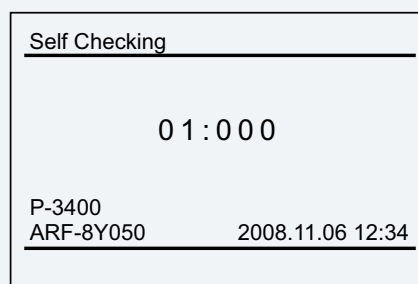

(4) LCD Test

Press "OK" and the screen will be switched as shown in the figure.

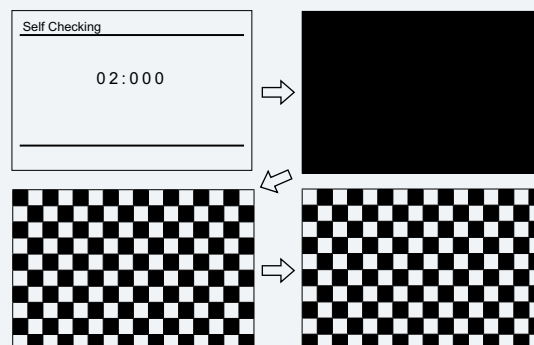

(5) Backlight Test

LCD brightness changes gradually by pressing "OK".

(6) Contrast Test

Contrast of the LCD gradually changes by pressing "OK".

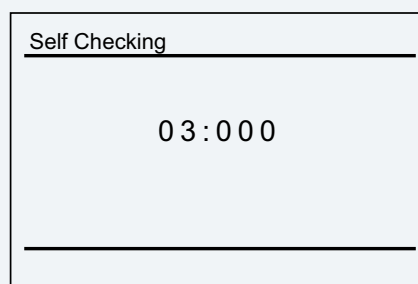

(7) Run Indicator Test

Press "OK" and the run indicator will flash in red and green twice for each.

(8) Switch Input Test

Press the 9 switches one by one. The number indicated with "A" will be counted up as switch being pressed.

* The order of pressing switch is at random.

Do not press more than 1 (one) button, for it will not be counted.

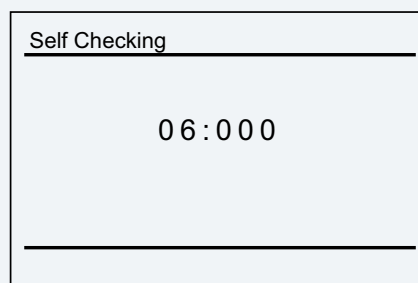

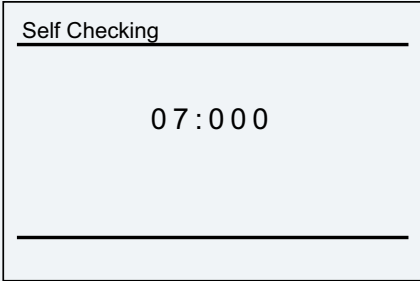
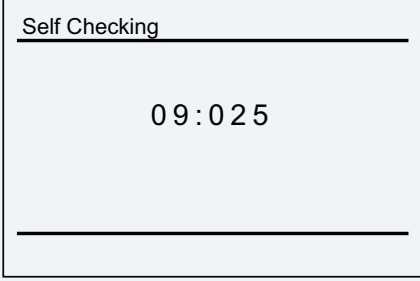
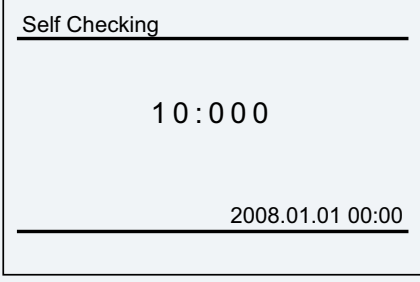
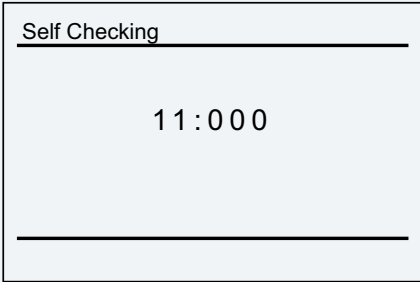
<p>(9) No Function</p> <p>This function is not used.</p> <p>Press "OK" to proceed.</p>	
<p>(10) Transmission Circuit Test</p> <p>The remote control switch automatically starts to check the transmission circuit.</p>	
<p>(11) Remote Control Switch Thermistor Test</p> <p>The temperature detected by remote control switch thermistor is displayed at "A" in the right figure.</p>	
<p>(12) Date/Time Test</p> <p>The date and time is switched from "2012.03.04 12:34" to "2008.01.01 00:00".</p>	
<p>(13) EEPROM Test</p> <p>< EEPROM Clearing Cancel ></p> <p>Press "?" (help).</p> <p>< EEPROM Clear ></p> <p>Press "OK" or wait 15 seconds. EEPROM data will be cleared. During the process, the numbers will be indicated on where "A" is located.</p> <p>If A indicates "999", EEPROM is in a faulty condition.</p> <p>*In case "A" indicates "999", the process does not proceed to next step.</p>	
<p>(14) After the several seconds pass, the self checking is completed and the remote control switch automatically restarts.</p>	

EEPROM process

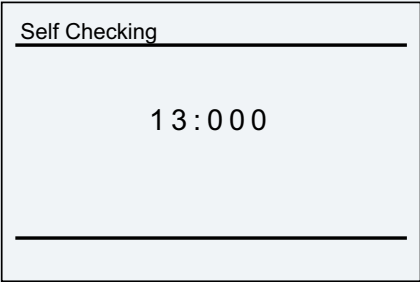
<p>(15) Clear EEPROM</p> <p>The remote control switch will automatically start EEPROM clearing process.</p>	
<p>(16) After the several seconds pass, the self checking is completed and the remote control switch automatically restarts.</p>	

8.3.3 Troubleshooting using the 7 segment display

◆ Simple checking by 7-segment display

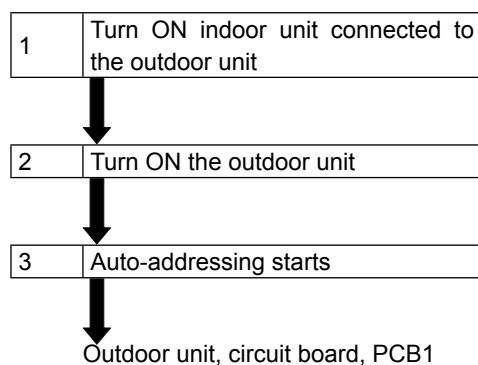

During auto-addressing, the following items can be checked using the outdoor unit's on-board 7-segment LED display:

- 1 Disconnection of power supply to the indoor unit.
- 2 Reverse connection of the operating line between the outdoor and indoor units.
- 3 Duplication of indoor unit number.

◆ Checking method by 7-segment display

Operating conditions and each part of refrigeration cycle can be checked by 7-segment and push switches (PSW) on the PCB in the outdoor unit. During checking data, do not touch the electric parts except for the indicated switches because 220-240V is applied to them. Pay attention not to contact the tools with electrical parts. If contacted, electrical parts will be damaged.

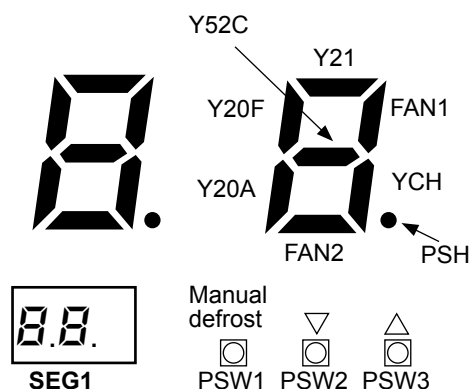

- To start checking, press PSW2 switch for more than three seconds.
- To proceed checking, press the PSW2 switch.
- To back to the previous item, press the PSW3 switch.
- To cancel this checking, press the PSW2 switch for more than 3 seconds.

◆ Check mode items

RAS-(2-2.5)HVNP / RAS-3HVNP

Item	Item		Indication data		
	Check No.	In-dic.	In-dic.	Contents	
Input/output state of outdoor micro-computer	01	SC	3	Indicates only for the segments corresponding to the equipment in the figure. (See figure above)	
Capacity of operating indoor unit	02	oP	11	00~199 In case that capacity is higher than 100, the last two digits flash	
Inverter order frequency to compressor	03	H1	74	0~115 (Hz) In case that frequency is higher than 100Hz, the last two digits flicker	
Indoor order frequency to compressor	04	H2	74	0~115 (Hz) In case that frequency is higher than 100Hz, last two digits flicker	
Air flow ratio	05	Fo	80	00~100 (%) In case that air flow ratio is 100%, "00" flashes	
Outdoor unit expansion valve opening	06	EO	30	00~100 (%) In case that expansion valve opening is 100%, "00" flashes	
Temperature at the top of compressor	07	Td	02	00~142 (°C) In case that temperature is higher than 100°C, the last two digits flash	
Evaporating temperature at heating	08	TE	12	-19~80°C	
Ambient air temperature	09	To	-3	-19~80°C	
Control PCB information	10	TF	20	Internal information of the PCB	
Control PCB information	11	A1	12	Internal information of the PCB	
Inverter secondary current	12	A2	20	00~199 (A) In case that current is higher than 100°C, the last two digits flash	
Outdoor unit address	13	nA	00	00~63	
Indoor unit expansion valve opening	14	EA	20	00~100 (%) In case that opening is 100%. "00" flashes	In case of twin/triple/quad-type unit, the information of 2nd to the 4th indoor units is indicated repeatedly.
Liquid pipe temperature of indoor unit (freeze protection)	15	LA	05	-19~127 (°C)	The right character of the indication represents the indoor unit setting No.
Indoor unit intake air temperature	16	IA	28	-19~127 (°C)	Single: A
Indoor unit discharge air temperature	17	oA	20	-19~127 (°C)	Twin: A, b
Cause of indoor unit stoppage	18	dA	05	(See table at the next page)	Triple: A, b, c Quad: A, b, c, d
Accumulated Operating Time of Compressor	19	UU	00	0 to 9,999 (x 10 hours) Alternately upper 2 digits and lower 2 digits are indicated every 0.5 sec.	
Accumulated Operating Time of Compressor	20	oU	00	0 to 9,999 (x 10 hours) Alternately upper 2 digits and lower 2 digits are indicated every 0.5 sec.	
Alarm code for abnormal stoppage of compressor	21	AC	08	Alarm code on compressor	
Cause of stoppage at inverter	22	iF	1	(See table at the next page)	
Abnormal data record	23	n1	00	One of the abnormal data record from latest (n1) to oldest (n9) is indicated. Alarm code or cause code is indicated.	
Total capacity of indoor unit connected	24	CP	22	00~96 In case that capacity is higher than 100, the last two digits flash	
Connected indoor unit number	25	AA	2	00~64	
Refrigerant adress	26	CA	0	00~63	

RAS-(3-12)H(V)NP(E)

Item	Item		Indication data	
	Check No.	In-dic.	In-dic.	Contents
Input/output state of outdoor micro-computer	01	SC	3	Indicates only for the segments corresponding to the equipment in the figure. (See figure above)
Capacity of operating indoor unit	02	oP	11	00~199 In case that capacity is higher than 100, the last two digits flash
Control software No.	03	SP	11	Control Software No. in use is indicated. Alternately upper 2 digits and lower 2 digits are indicated every 0.5 sec.
Inverter software No.	04	iP	11	Control Software No. in use is indicated. Alternately upper 2 digits and lower 2 digits are indicated every 0.5 sec.
Inverter order frequency to compressor	05	H1	74	0~115 (Hz) In case that frequency is higher than 100Hz, the last two digits flicker
Air flow ratio	06	Fo	80	00~15
Outdoor unit expansion valve opening	07	EO	30	00~100 (%) In case that expansion valve opening is 100%, "00" flashes
Discharge pressure (high)	08	Pd	30	0.1 to 4.9 MPa
Temperature at the top of compressor	09	Td	02	00~142 (°C) In case that temperature is higher than 100°C, the last two digits flash
Evaporating temperature at heating	10	TE	-12	-19~80°C
Ambient air temperature	11	To	-3	-19~80°C
Inverter fin temperature	12	TF	20	-10~100 (°C) In case that temperature is 100%, "00" flashes
Inverter firstly current	13	A1	12	00~199 (A) In case that current is higher than 100°C, the last two digits flash
Inverter secondary current	14	A2	20	00~199 (A) In case that current is higher than 100°C, the last two digits flash
Outdoor unit address	15	nA	00	00~63
Indoor unit expansion valve opening	16	EA	20	00~100 (%) In case that opening is 100%. "00" flashes
Liquid pipe temperature of indoor unit (freeze protection)	17	LA	05	-19~127 (°C)
Indoor unit intake air temperature	18	iA	28	-19~127 (°C)
Indoor unit discharge air temperature	19	oA	20	-19~127 (°C)
Cause of indoor unit stoppage	20	dA	05	(See table at the next page)
Accumulated Operating Time of Compressor	21	UJ	00	0 to 9,999 (x 10 hours) Alternately upper 2 digits and lower 2 digits are indicated every 0.5 sec.
Accumulated Operating Time of Compressor	22	cU	00	0 to 9,999 (x 10 hours) Alternately upper 2 digits and lower 2 digits are indicated every 0.5 sec.
Alarm code for abnormal stoppage of compressor	23	AC	08	Alarm code on compressor
Cause of stoppage at inverter	24	iF	1	(See table at the next page)
Abnormal data record	25	n1	00	One of the abnormal data record from latest (n1) to oldest (n9) is indicated. Alarm code or cause code is indicated.
Total capacity of indoor unit connected	26	CP	22	00~199 In case that capacity is higher than 100, the last two digits flash
Connected indoor unit number	27	AA	2	00~64
Refrigerant adress	28	OR	0	00~63

RAS-(4-12)H(V)NC(E)

Item	Item		Indication data	
	Check No.	In-dic.	In-dic.	Contents
Input/output state of outdoor micro-computer	01	SC	3	Indicates only for the segments corresponding to the equipment in the figure. (See figure above)
Capacity of operating indoor unit	02	oP	11	00~199 In case that capacity is higher than 100, the last two digits flash
Control software No.	03	SP	11	Control Software No. in use is indicated. Alternately upper 2 digits and lower 2 digits are indicated every 0.5 sec.
Inverter software No.	04	iP	11	Control Software No. in use is indicated. Alternately upper 2 digits and lower 2 digits are indicated every 0.5 sec.
Inverter order frequency to compressor	05	H1	74	0~115 (Hz) In case that frequency is higher than 100Hz, the last two digits flicker
Air flow ratio	06	Fo	80	00~15
Outdoor unit expansion valve opening	07	EO	30	00~100 (%) In case that expansion valve opening is 100%, "00" flashes
Temperature at the top of compressor	08	Td	02	00~142 (°C) In case that temperature is higher than 100°C, the last two digits flash
Evaporating temperature at heating	09	TE	42	-19~80°C
Ambient air temperature	10	To	-3	-19~80°C
Condensing temperature	11	Tc	40	-19~80°C
Inverter fin temperature	12	TF	20	-10~100 (°C) In case that temperature is 100%, "00" flashes
Inverter firstly current	13	A1	12	00~199 (A) In case that current is higher than 100°C, the last two digits flash
Inverter secondary current	14	A2	20	00~199 (A) In case that current is higher than 100°C, the last two digits flash
Outdoor unit address	15	nA	00	00~63
Indoor unit expansion valve opening	16	EA	20	00~100 (%) In case that opening is 100%. "00" flashes
Liquid pipe temperature of indoor unit (freeze protection)	17	LA	05	-19~127 (°C)
Indoor unit intake air temperature	18	iA	28	-19~127 (°C)
Indoor unit discharge air temperature	19	oA	20	-19~127 (°C)
Cause of indoor unit stoppage	20	dA	05	(See table at the next page)
Accumulated Operating Time of Compressor	21	UJ	00	0 to 9,999 (x 10 hours) Alternately upper 2 digits and lower 2 digits are indicated every 0.5 sec.
Accumulated Operating Time of Compressor	22	cU	00	0 to 9,999 (x 10 hours) Alternately upper 2 digits and lower 2 digits are indicated every 0.5 sec.
Alarm code for abnormal stoppage of compressor	23	AC	08	Alarm code on compressor
Cause of stoppage at inverter	24	i	1	(See table at the next page)
Abnormal data record	25	n1	00	One of the abnormal data record from latest (n1) to oldest (n9) is indicated. Alarm code or cause code is indicated.
Total capacity of indoor unit connected	26	CP	22	00~199 In case that capacity is higher than 100, the last two digits flash
Connected indoor unit number	27	AA	2	00~64
Refrigerant adress	28	OR	0	00~63

In case of twin/triple/quad-type unit, the information of 2nd to the 4th indoor units is indicated repeatedly.

The right character of the indication represents the indoor unit setting No.

Single: A
Twin: A, b
Triple: A, b, c
Quad: A, b, c, d

◆ Cause of indoor unit stoppage (dR)

Indication	Contents
00	Operation OFF, Power OFF
01	Thermo-OFF
02	Alarm
03	Freeze protection overheating protection
05	Instantaneous power failure at outdoor unit
06	Instantaneous power failure at indoor unit
07	Stoppage of heating operation due to high outdoor air temperature
10	Demand thermo OFF
13	Retry for Pd increase prevention
15	Vacuum/discharge gas temperature increase retry
16	Retry due to discharge gas SUPERHEAT decrease
17	IPM error retry, instantaneous over current of inverter retry, electronic thermal activation of inverter retry, abnormal current sensor of inverter retry
18	Retry due to inverter voltage decrease Retry due to Inverter Overvoltage Retry due to inverter transmission abnormality
19	Other retry
21	Forced Thermo-OFF
22	Outdoor hot start control
24	Thermo-OFF during energy saving operation mode
26	Retry due to high pressure decrease
28	Cooling air discharge temperature decrease
33	Forced Thermo-OFF
34	Forced Thermo-OFF
35	Retry due to abnormal operating mode (Reversing valve switching failure)

i Demand thermo OFF:

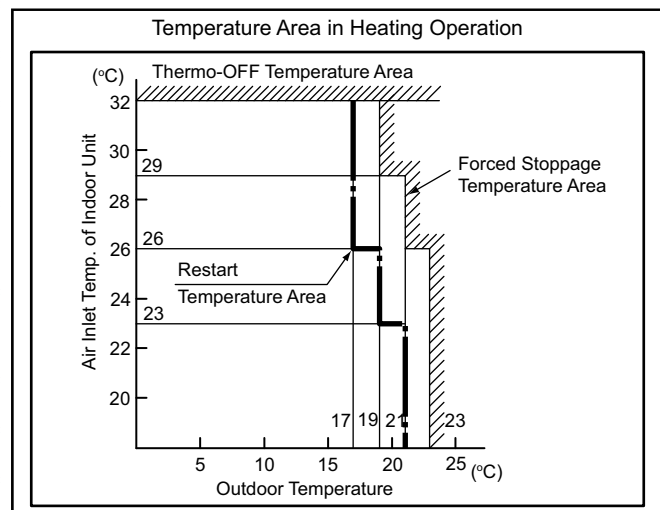

NOTE

- The cause code for indoor unit stoppage is not always “02” (Alarm) during stoppage by the abnormality. If the unit is under Thermo-OFF by other cause of stoppage before “02” (Alarm) occurs, the previous cause code for indoor unit stoppage remains.
- When the transmitting between the inverter PCB and the outdoor unit PCB1 is disconnected for 30 seconds, the outdoor micro-computer will be reset. Accordingly when the alarm code “04” (Abnormal Transmitting between Inverter PCB and Outdoor Unit PCB1) occurs, the cause code for indoor unit stoppage may be indicated “05”.
- When the transmitting between the indoor unit and the outdoor unit is disconnected for 3 minutes, the indoor micro-computer will be reset. Accordingly when the alarm code “03” (Abnormal Transmitting between Indoor Unit and Outdoor Unit) occurs, the cause code for indoor unit stoppage may be indicated “06”.
- For twin, triple and quad combination, if the cause code for indoor unit stoppage “01” is indicated, check the cause of stoppage for other indoor units.
- Cause code for indoor unit stoppage “22” is indicated when it is forced thermo-OFF during compressor pre-heating for RAS-12HN(P/C) models.

Cancellation of Forced Thermo OFF (21)

Turn ON the power source and wait for more than 30 seconds. Then press PSW1 and PSW3 simultaneously for more than 3 seconds.

Forced thermo-OFF (indoor unit error code 21) will be cancelled.

However, this function may damage the compressor, use only on inevitable occasion.

- In case of using the remote control switch (PC-ART), the cancellation is also available with it.
- When "Operation Lock" indication flashes on the remote control LCD, press FAN SPEED and LOUVER switches simultaneously for more than 3 seconds.
- "Operation Lock" Indication is disappeared and operation is available.

◆ Cause of inverter stoppage (24)

Code	Cause	Cause of Stoppage for Corresponding Unit	Remark	
			Indication during Retry	Alarm Code
1	Automatic Stoppage of Transistor Module (DIP-IPM Error) (Overcurrent, Undercurrent, Temperature increase)	17	P7	53
2	Instantaneous Over Current	17	P7	48
3	Abnormal Inverter Fin Thermistor	17	P7	54
4	Electronic Thermal Activation (Inverter overcurrent)	17	P7	48
5	Inverter Voltage Decrease (Undervoltage)	18	P8	06
6	Over Voltage	18	P8	06
7	Abnormal Inverter Transmission	18	-	-
8	Abnormal Current Detection	17	P7	51
9	Instantaneous Power Failure Detection	18	-	-
11	Reset of Micro-Computer for Inverter	18	-	-
12	Earth Fault Detection from Compressor (Only Starting)	17	P7	53
13	Phase detection abnormality	18	P8	-
14	Inverter Non-Operation	18	-	55
15	Inverter Non-Operation	18	-	55
16	Inverter Non-Operation	18	-	55
17	Communication Abnormality	18	-	55
18	Protection Device Activation (PSH)	-	-	02
19	Protection Detection Device Abnormality	-	-	38
20	Early Return Protection Device	18	P7	53
21	Step-Out Detection	17	-	31

8

◆ Table of capacity codes of indoor unit

Code	Equivalent horsepower	Code	Equivalent horsepower	Code	Equivalent horsepower
05	0.8	14	2.0	40	5.0
08	1.0	16	2.3	48	6.0
10	1.3	18	2.5	54	8.0
11	1.5	22	3.0	80	10.0
13	1.8	32	4.0		

◆ **Protection control code on 7-segment display**

- 1 Protection control code is displayed on 7-segment when a protection control is activated.
- 2 Protection control code is displayed while function is working, and goes out when released.
- 3 When several protection control are activated, code number with higher priority will be indicated (see below for the priority order).
 - a. Higher priority is given to protection control related to frequency control than the other. Priority order:
 - ◆ High-pressure increase protection
 - ◆ Over current protection
 - ◆ Cold draft protection
 - b. In relation to retry control, the latest retrial will be indicated unless a protection control related to frequency control is indicated.

RAS-(2-2.5)HVNP / RAS-3HVNC

Priority	Protection control	Code
1	Low-Pressure Ratio Control at Cooling Operation	P00
2	High-pressure ratio control at heating operation	P01
3	High-pressure rise protection	P02
4	Current protection	P03
5	Inverter fin temperature rise prevention	P04
6	Discharge gas temperature rise protection	P05
7	Unbalance Power Source Detecting	P09
8	Demand current control	P0A
9	Low-Pressure Decrease Protection	P0b

RAS-(3-12)H(V)N(P/C)(E)

Priority	Protection control	Code
1	Pressure ratio control	P01
2	High-pressure rise protection	P02
3	Current protection	P03
4	Inverter fin temperature rise prevention	P04
5	Discharge gas temperature rise protection	P05
6	Demand current control (running current limit control)	P0A
7	High pressure decrease protection (only Premium series)	P09

**NOTE**

The protection control code being indicated on 7-segment display is changed to an alarm code when the abnormal operation occurs. Also, the same alarm code is indicated on the remote control switch.

◆ Activating condition of protection control code

To monitor the conditions such as the temperature change and others, the control of the frequency and other controls are performed by the protection control in order to prevent the abnormal operations. The activating conditions of protection control are shown in the table below:

RAS-(2-2.5)HVNP / RAS-3HVNC

Code	Protection Control	Activating Condition	Remarks
P0	Low-Pressure Ratio Control at Cooling Operation	If Compression Ratio ϵ exceeds a threshold value => Frequency Increase	—
P1	High-Pressure Ratio Control at Heating Operation	If Compression Ratio ϵ is lower than a threshold value => Frequency Decrease	—
P2	High-Pressure Increase Protection	High Pressure Switch for Control is activated => Frequency Decrease	—
P3	Over Current Protection	Inverter Output Current > (*1)A => Frequency Decrease	—
P4	Inverter Temperature Increase Protection	Inverter Fin Temperature RAS-(2-2.5)HVNP / RAS-3HVNC ≥ 70 °C => Frequency Decrease	—
P5	Discharge Gas Temperature Increase Protection	Temperature at the top of compressor is high => Frequency Decrease	—
P9	Unbalance Power Source Detecting	Inverter Output Current exceeds a threshold value => Frequency Decrease	—
PA	Current Demand Control	Inverter Output Current exceeds a threshold value => Frequency Decrease	In case of Demand Control Setting
Pb	Low-Pressure Decrease Protection	Low Pressure Switch for Control is activated. => Frequency Decrease	—

(1*)

Connection	220-240V		
	2	2.5	3
HP	2	2.5	3
Current (A)	8.0	8.0	10.5

RAS-(3-12)H(V)N(P/C)(E)

Code	Protection control	Activating condition	Remarks
P01	Pressure ratio control	Compression ratio $\varepsilon \geq 7.5 \Rightarrow$ frequency decrease Compression ratio $\varepsilon \leq 1.6 \Rightarrow$ frequency increase	$\varepsilon = (Pd+0.1)/(Ps+0.1)$
P02	High-pressure increase protection	High Pressure Switch for Control is activated \Rightarrow Frequency Decrease	
P03	Inverter current protection	If Inverter PCB secondary current $> (*1)A$ \Rightarrow frequency decrease	
P04	Inverter fin temperature increase prevention	Inverter fin temperature RAS-3HVNPE / RAS-(4-6)HN(P/C)E ≥ 70 °C RAS-(4-6)HVNPE ≥ 80 °C RAS-(4-6)HVNCE ≥ 87 °C RAS-(8-12)HN(P/C)(E) ≥ 82 °C \Rightarrow frequency decrease	
P05	Discharge gas temperature increase protection	Temperature at the top of compressor is high \Rightarrow frequency decrease (Maximum temperature is different depending on the frequency) Temperature at the top of compressor > 107 °C \Rightarrow Indicate P5	
P09	High-pressure decrease protection	Discharge pressure of compressor decrease under 10MPa \Rightarrow Frequency increase	Cooling operation and lowest step fan or heating operation
P0A	Demand current control (running current limit control)	Compressor run current \geq demand setting value \Rightarrow frequency decrease	Demand setting value: upper limit of total running current is set to 100%, 80%, 70%, 60% at normal operation using input on PCB1

Ps: Suction pressure of compressor (MPa)

Pd: Discharge pressure of compressor (MPa)

(*1)

Connection	380-415V						220-240V				
	HP	4	5	6	8	10	12	3	4	5	6
Current (A)		12.0	12.0	12.0	17.5	19.0	20.0	16.0	16.0	24.0	24.0

**NOTE**

- **During protection control (except during alarm stoppage), the protection control code is indicated.**
- **The protection control code is indicated during protection control and turns off when cancelling the protection control.**
- **After retry control, the condition of monitoring is continued for 30 minutes.**

8.4 Checking procedure for main parts

8.4.1 Procedure for checking the DIP-IPM inverter for indoor and outdoor units

◆ RAS-(3-6)H(V)N(P/C)E

High voltage discharge work for replacing parts

CAUTION

Electrical hazard. Risk of electrical shock. Perform this high voltage discharge work to avoid an electric shock.

- 1 Turn OFF the main switches and wait for three minutes. Make sure that no high voltage exists. If LED201 is ON after start-up and LED201 is OFF after turning OFF power source, the voltage will decrease lower than DC50V.
- 2 Connect connecting wires to an electrical soldering iron
- 3 Connect the wires to terminals, P and N on DIP-IPM. (The discharge voltage can perform even when connecting the wires to terminals #1(P) and #3(N) of connector "PCN201") => Discharging is started, resulting in hot soldering iron. Pay attention not to short-circuit between terminal P(+) and N(-)
- 4 Wait for 2 or 3 minutes and measure the voltage once again. Check to ensure that no voltage is charged.

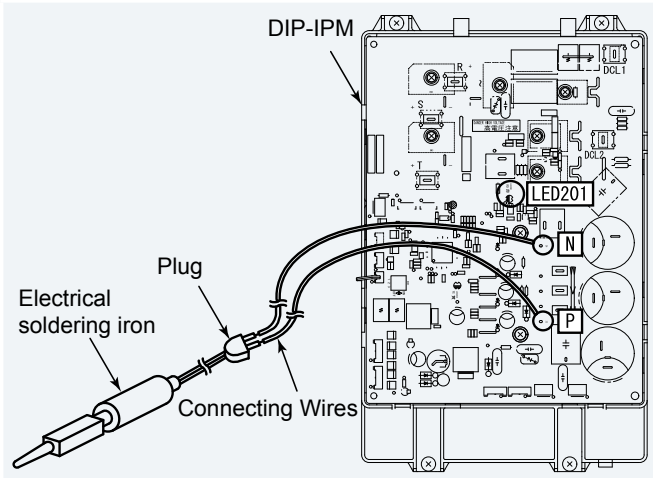

Inverter module checking procedure

- Rectifier circuit of inverter PCB

Internal circuit of rectified part of DIP-IPM

Remove all the terminals of the inverter PCB before checking.

Non-faulty if [1] – [8] are checked and satisfied.

Measure with 1 kΩ range of a tester.

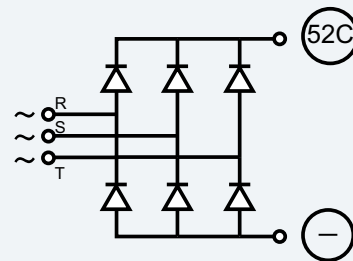

NOTE

DO NOT use a digital tester.

- 1 Touch [+] side of the tester to DIP-IPM 52C terminal, and [-] side to DIP-IPM R, S and T terminals to measure the resistance. Normal if all three terminals have 1 k Ω or greater.
- 2 Contrary to [1], touch [-] side of the tester to DIP-IPM 52C terminal, and [+] side to DIP-IPM R, S terminals to measure the resistance. Normal if all three terminals have 100 k Ω or greater.
- 3 Touch [-] side of the tester to [-] side of DIP-IPM DMI (soldered part), and [+] side of the tester to DIP-IPM R, S terminals to measure the resistance. Normal if all three terminals have 1 k Ω or greater
- 4 Contrary to [3], touch [+] side of the tester to [-] side of DIP-IPM DMI, and [-] side of the tester to DIP-IPM R, S terminals to measure the resistance. Normal if all three terminals have 100 k Ω or greater.

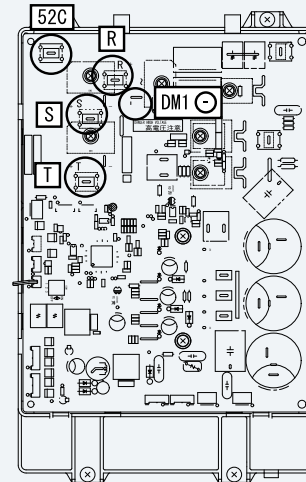

- 5 Touch [+] side of the tester to [P] of DIP-IPM (soldered part), and [-] side to DIP-IPM U, V, W terminals to measure the resistance. Normal if all three terminals have 1 k Ω or greater.
- 6 Contrary to [5], touch [-] side of the tester to [P] of DIP-IPM (soldered part), and [+] side to DIP-IPM U, V, W terminals to measure the resistance. Normal if all three terminals have 30 k Ω or greater. (Resistance gradually increases during measurement.)
- 7 Touch [-] side of the tester to [N] of ISPM (soldered part), and [+] side to ISPM U, V, W terminals to measure the resistance. Normal if all three terminals have 1 k Ω or greater.
- 8 Contrary to [7], touch [+] side of the tester to [N] of DIP-IPM (soldered part), and [-] side to DIP-IPM U, V, W terminals to measure the resistance. Normal if all three terminals have 30 k Ω or greater. (Resistance gradually increases during measurement.)

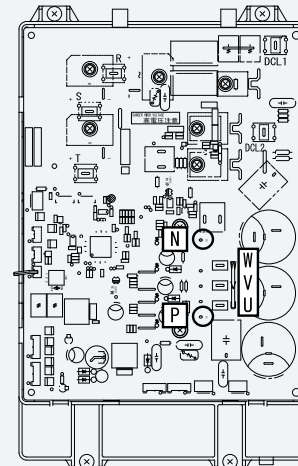
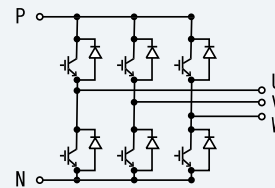

- ACT circuit of inverter PCB

Internal circuit of ACT part of inverter module
Non-faulty if [9] – [13] are checked and satisfied.
(Measure with 1 k Ω range of a tester.)

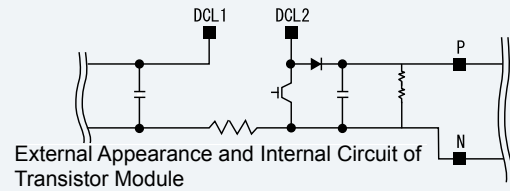

NOTE

DO NOT use a digital tester.

- 9 Check items [1] – [8].
- 10 Touch [+] side of the tester to DIP-IPM DCL2 terminal, and [-] side to [P] of ISPM/DIP-IPM (soldered part) to measure the resistance. Normal if all three terminals have 100 k Ω or greater
- 11 Contrary to [10], touch [-] side of the tester to DIP-IPM DCL2 terminal, and [+] side to [P] of DIP-IPM (soldered part) to measure the resistance. Normal if all three terminals have 1 k Ω or greater.
- 12 Touch [+] side of the tester to DIP-IPM DCL2 terminal, and [-] side to [N] of DIP-IPM (soldered part) to measure the resistance. Normal if all three terminals have 100 k Ω or greater.
- 13 Contrary to [12], touch [-] side of the tester to DIP-IPM DCL2 terminal, and [+] side to [N] of DIP-IPM (soldered part) to measure the resistance. Normal if all three terminals have 10 k Ω or greater. (Resistance gradually increases during measurement.)

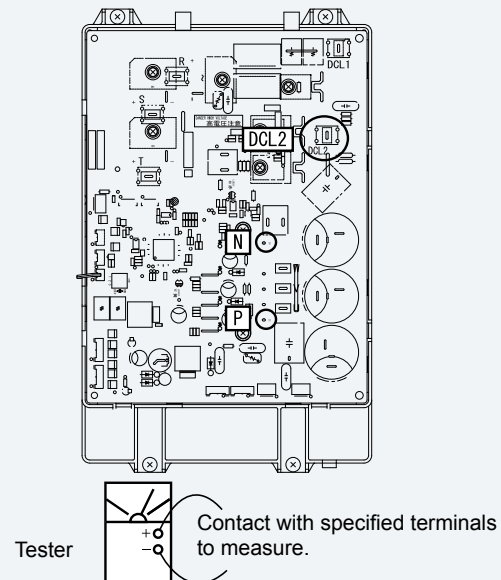

- Checking Method of Resistance for Inrush Current Prevention (Built-in Thermal Fuse)

(Measure the resistance under 1 k Ω range of a circuit tester.)

NOTE

DO NOT use a digital tester.

By placing the \oplus side of tester to the \oplus side of DM1 (soldering portion) on inverter PCB and the \ominus side of tester to DCL1 on inverter PCB, measure the resistance. If the resistance is around 500 Ω , it is normal. If the resistance is 0 Ω or infinity Ω , it is abnormal.

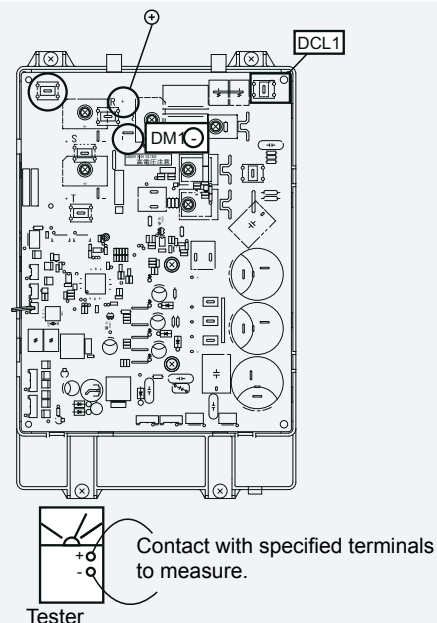

- Checking Method of Fuse for fan motor protection (EF1)
(Measure the resistance under 1 k Ω range of a circuit tester.)

i NOTE

DO NOT use a digital tester.

By placing the \oplus and \ominus side of tester to EF1 on inverter PCB, measure the resistance.

If the resistance is 0 Ω , it is normal.

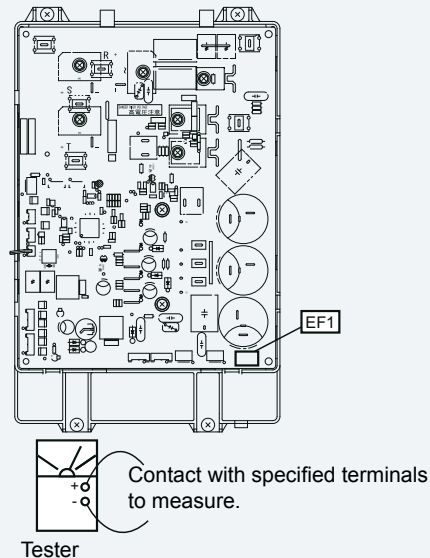

◆ RAS-(8-12)HN(P/C)(E)

High voltage discharge work for replacing parts

⚠ CAUTION

Electrical hazard. Risk of electrical shock. Perform this high voltage discharge work to avoid an electric shock.

- 1 Turn OFF the main switches and wait for three minutes. Check to ensure that no high voltage exists. If LED2 is ON after start-up and LED2 is OFF after turning OFF power source, the voltage will decrease lower than DC50V.
- 2 Connect connecting wires to an electrical solder bit.
- 3 Connect the wires to terminals, P and N on IPM. => Discharging is started, resulting in hot solder bit. Pay attention not to short-circuit between terminal P and N.
- 4 Wait for 2 or 3 minutes and measure the voltage once again. Check to ensure that no voltage is charged.

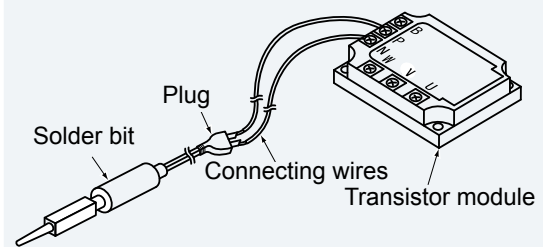

Transistor module checking procedure

Outer Appearance and Internal Circuit of Transistor Module

1. Drive circuit.
2. Overheating protection circuit.
3. Sensor.

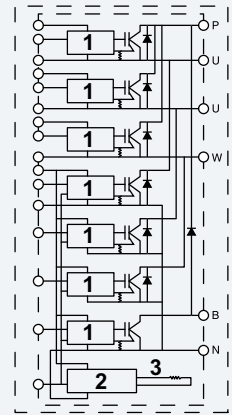
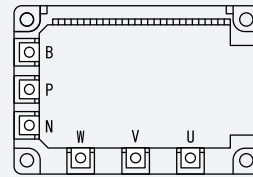

Procedure:

Remove all the terminals of the transistor module before check. If items [1] – [4] are performed and the results are satisfactory, the transistor module is normal.

Measure it under 1k Ω range of a tester.



NOTE

DO NOT use a digital tester.

- 1 By touching the + side of the tester to the P terminal of transistor module and the - side of tester to U, V and W of transistor module, measure the resistance. If all the resistances are from 1 to 5k Ω , it is normal.

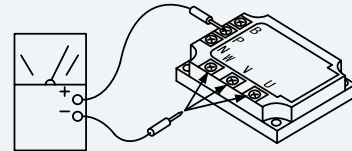

- 2 By touching the - side of the tester to the P terminal of transistor module and the + side of tester to U, V and W of transistor module, measure the resistance. If all the resistances are greater than 100k Ω , it is normal.

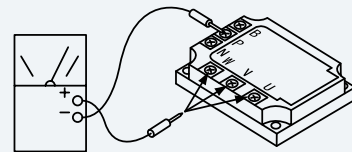

- 3 By touching the - side of the tester to the N terminal of transistor module and the + side of tester to U, V and W of transistor module, measure the resistance. If all the resistances are from 1 to 5k Ω , it is normal.

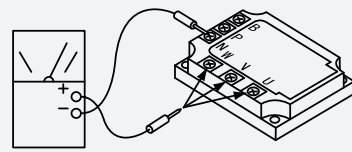

- 4 By touching the + side of the tester to the N terminal of transistor module and the - side of tester to U, V and W of transistor module, measure the resistance. If all the resistances are greater than 100k Ω , it is normal.

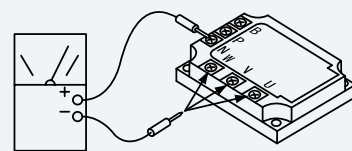

Diode module checking procedure

Outer appearance and internal circuit of diode module:

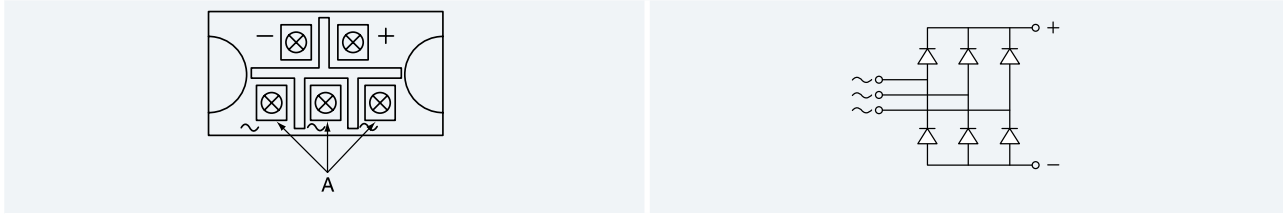

If items [1] – [4] are performed and the results are satisfactory, the diode module is normal.

Measure it under 1k Ω range of a tester.

**NOTE**

DO NOT use a digital tester.

- 1 By touching the + side of the tester to the + terminal of diode module and the - side of tester to the ~ terminals (A) of the diode module, measure the resistance. If all the resistances are from 5 to 50k Ω , it is normal.

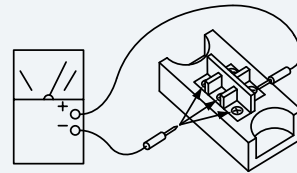

- 2 By touching the - side of the tester to the + terminal of diode module and the + side of tester to the ~ terminals (A) of the diode module, measure the resistance. If all the resistances are greater than 500k Ω , it is normal.

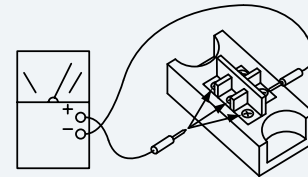

- 3 By touching the - side of the tester to the - terminal of diode module and the + side of tester to the ~ terminals (A) of the diode module, measure the resistance. If all the resistances are from 5 to 50k Ω , it is normal.

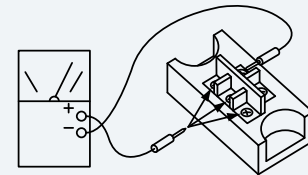

- 4 By touching the + side of the tester to the - terminal of diode module and the - side of tester to the ~ terminals (A) of the diode module, measure the resistance. If all the resistances are greater than 500k Ω , it is normal.

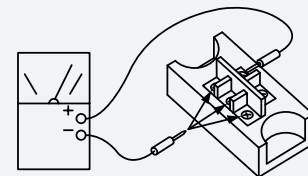

8.4.2 Checking capacitors CB1 & CB2.

DANGER:

- **Electrical hazard. Risk of serious injuries or death.**
- **Before installing the electrical wiring or before performing a periodical check, turn OFF the main switch of the unit. For safety reasons, be sure that the fan is stopped.**
- **Prevent from touching the capacitors' terminals. High voltage should be present before discharging them.**
- **Turn off the unit and wait for the LED 201 to be off before touching the components.**

If it's possible, check the capacitance of each capacitor : $4700\mu\text{F} \pm 20\%$ (between $3760\mu\text{F}$ to $5640\mu\text{F}$).

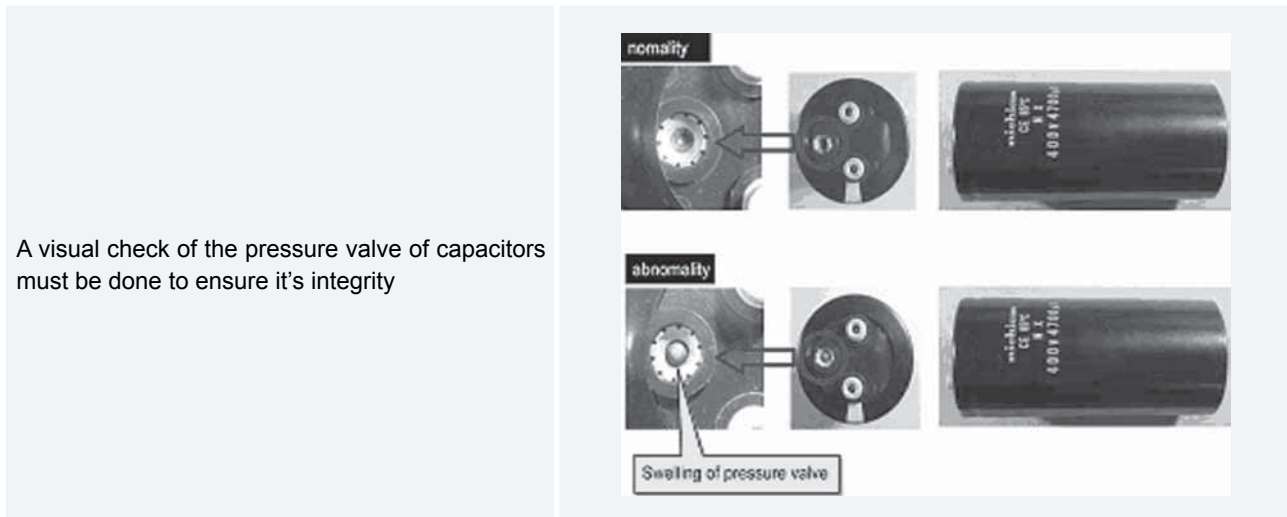

NOTE

It is not recommended to check tension.

$PN = \text{Power source} \times \sqrt{2}$, $PC = CN$ is nearly equal to $PN/2$.

R1 & R2:

- 1 If the value is different:
 - Capacitor could be damaged by overload.
 - 04 alarm could be displayed if low supply voltage (CN) for ISPM control part is present.
- 2 $R1 = 9.5\Omega$ & $R2 = 14.0\Omega$. If these values are different, the capacitors will be not properly charged.

Resistance between P1 & TB3 = $2k\Omega$ (white resistance in the ISPM).

In case that Mg. SW 52C (CMC1) is not ON, the compressor current will travel through these resistances, and they will be broken. Mg. SW 52C (CMC1) should be checked. Check the resistance between the primary and secondary terminal where the contact point is melted for Mg. SW 42C. If there is continuity, the contact is melted and 52C is broken (NG).

Reactor resistance can be measured between TB3 and RB = $0,2\Omega$. Checking this component is not necessary.

NOTE

- **Noise filter does not affect ISPM directly, so is not necessary to check it when ISPM fails.**
- **Both digital or analog testers are valid to check the values.**

8.4.3 Fault diagnosis of DC fan motor.

When ISPM/DIP-IPM is faulty and Alarm 03, 04 or 53 appears, the fan motor may also be damaged. To prevent ISPM/DIP-IPM damage which may result from operation combined with a faulty fan motor, check also if the fan motor is not damaged when ISPM/DIP-IPM is replaced



CAUTION

- **Turn OFF main power before start working.**
- **Working and checking with the power ON may disturb correct diagnosis and may result in failure.**

Models with DC motor(s)	N° of motors
RAS-(2-2.5)HVNP RAS-3HVNC RAS-3HVNPE RAS-(4-6)H(V)NCE	1 Pieces
RAS-12HN(P/C)	1 Pieces above
RAS-(4-6)H(V)NPE RAS-(8-10)HN(P/C)E	2 Pieces

Procedure in case of error diagnosis

- 1 Remove fan motor connectors for DC fan motor from the control PCB, ISPM or DIP-IPM and turn the fan motor shaft by hand.

Normal	Fan motor shaft turns smoothly
Normal	The fan motor shaft turns smoothly.
Faulty	No continuous rotary torque movement felt when turning the motor by hand. This occurs because the internal magnet of the fan motor breaks the movement when the internal electronic circuit of the fan motor has a short-circuit fault.

- 2 Measure the fan motor resistance:

Measurement procedure	
1	Remove the fan motor connector from the control PCB, ISPM or DIP-IPM.
2	Connect the black test lead of the tester to the black wire pin of the fan motor connector.
3	Connect the red test lead to the wire connector pin to be checked.
Results	
Normal	Observed values will be close to the normal values in the table below.
Faulty	Observed values will be deviated from the normal values in the table below. (Generally, an open-circuit fault shows ∞ , and a short-circuit fault shows several Ω - k Ω). Internal electronic circuit fault of the fan motor including short-circuit and breakage can be checked.

Model	Motor model	Wire color for checking (Normal value)			
		Red-black	White-black	Yellow-black	Blue-black
RAS-(2-2.5)HVNP RAS-3HVNC	FPD10U40S-902		1M Ω or greater		1M Ω or greater
RAS-(3-6)H(V)NPE (both)	SIC-61FW-D858	1M Ω or greater			1M Ω or greater
RAS-(4-6)H(V)NCE	EQDW04AHT	∞		∞	
RAS-(8-10)HN(P/C)E (both) RAS-12HN(P/C)	SIC-81FW-8183	1M Ω or greater			1M Ω or greater



NOTE

Values are shown for referential purpose. While actual values may vary depending on the type of the tester, any tester can be used to determine any short-circuit or breakage based on ∞ or several Ω or 0 Ω or ∞ .

8.4.4 Checking procedure for the electronic expansion valve for indoor and outdoor units

	Indoor unit electronic expansion valve	Outdoor unit electronic expansion valve
Locked with fully closed	Check the liquid pipe temperature during the heating process. It is abnormal if the temperature does not increase.	It is abnormal if the liquid pipe pressure does not increase during the pump down process.
Locked with slightly open	It is abnormal under the following condition: The temperature of the freeze protection thermistor becomes lower than the suction air temperature when the unit which is under check stops and the other units are under the pump down process.	It is abnormal if the liquid pipe pressure does not increase and the outlet temperature of the expansion valve decreases after the pump down process starts.
Locked with fully open		It is abnormal under the following conditions: after the heating process for more than 30 minutes, the discharge gas temperature of the compressor is not 10°C higher than the condensing temperature and there is no other faults, such as an excessive charge of refrigerant and others.

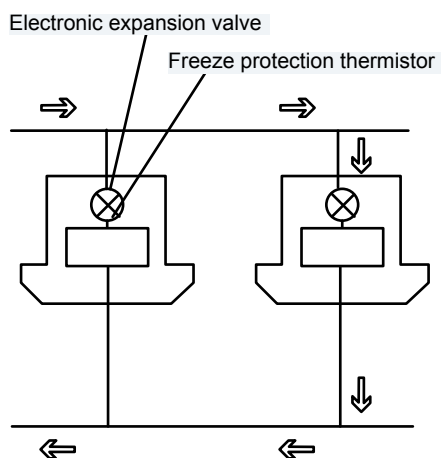

8.4.5 Checking procedure for AC fan motor

Part name	Unit models	Fan motor rated capacity	Wiring diagram	Lead wire colour	Resistance (Ω) (at 20°C)
Fan motor	RAS-12HN(P/C)	KFC6S-201SA3P 200W		Black-White Black-Blue Black-Red	17.0+/-10% 25.3+/-10% 20.1+/-10%



8.4.6 Checking procedure for other parts

Part name	Model code	Resistance (Ω)	Unit models
Solenoid Valve Coil	SR10D	1250	RAS-(3-12)H(V)NP(E) RAS-(4-12)H(V)NC(E)
		(at 20°C)	
Reversing Valve Coil	VHV-01AP552B1	1473	RAS-(3-12)H(V)NP(E)
	STF-G01AG579A1	950	RAS-(2-2.5)HVNP RAS-(3-12)H(V)NC(E)
Compressor	EU1014D9	1.138	RAS-2HVNP
	EU140XA2	1.138	RAS-2.5HVNP
	EU180XA1	1.138	RAS-3HVNC
	2YC45HXD	0.644	RAS-3HVNPE
	2YC63FXD	0.310	RAS-4H(V)NCE
	E402HHD-36A2	0.460	RAS-(4-6)H(V)NPE
	E401HHD-36A2	0.282	RAS-(5-6)H(V)NCE
	E507DHD-50A2	0.136	RAS-8HNPE
	E657DHD-65A2	0.094	RAS-(10-12)HNP(E)
	E655DHD-65D2	0.199	RAS-(8-12)HNC(E)
Magnet Contactor	FC-1/SP	460	RAS-(8-12)HN(P/C)(E)
	FC-0/SP	1150	RAS-(3-6)H(V)NPE

◆ **Checking procedure for the compressor**

CHECK LIST ON COMPRESSOR

Client:		Model:	Date:	
Serie No.		Production Date:	Checker:	
No.	Check item	Check method	Result	Remarks
1	Is THM9 correctly connected? THM9: Discharge Gas Thermistor	1. Is wire of thermistor correctly connected by viewing? 2. Check to ensure the 7-segment indication of Td when comp. is operating. Td: Temperature of THM9		
2	Is thermistor THM9 disconnected?	1. Check to ensure that thermistor on the top of comp. is correctly mounted by viewing? 2. Check to ensure that actually measured temp. is the same as the indication during check mode.		
3	Is current sensor faulty?	1. Check to ensure that indication A1 and A2 are 0 during compressor stopping.		
4	Is current sensing part on PCB2 faulty?	2. Check to ensure that indication A1 and A2 are not 0 during compressor running.		
5	Is the direction of current sensor CTU, CTV reverse?	Check the direction => by viewing.		
6	Are power source wires, U and V inserted correctly into current sensor? .	Check to ensure that wires are correctly inserted		
7	Is exp. valve (MV1) correctly connected?	Check to ensure that MV1 to CN5A is correctly connected		
8	Is exp. valve coil (MV1) correctly connected?	Check to ensure that each coil is correctly mounted on the valve.		
9	Are the refrigeration cycle and electrical wiring system incorrectly connected?	Check to ensure that refrigerant is flowing into indoor units by operating one refrigerating cycle only from the outdoor unit.		
10	Is opening of exp. valve completely closed (locked)?	Check the following by the check mode of outdoor units. 1. Liquid Pipe Temp. (TL) < Air Intake Temp. (Ti) during Cooling Operation 2. Liquid Pipe Temp. (TL) > Air Intake Temp. (Ti) during Heating Operation		
11	Is opening of exp. valve fully opened (locked)?	Check to ensure that liquid pipe temp. is lower than air intake temp. of stopping indoor unit when other indoor units are operating under cooling operation.		
12	Are the contacts for comp. magnetic switch CMC1 faulty?	Check the surface of each contact (L1, L2 and L3) by viewing.		
13	Is there any voltage abnormality among L1-L2, L2-L3 and L3-L1?	Check to ensure that voltage imbalance is smaller than 3%. Please note that power source voltage must be within 380V or 220V+10%.		
14	Is the comp. oil acidified during compressor motor burning?	Check to ensure that the oil color is not black.		

Additional Information for “CHECK LIST ON COMPRESSOR”

Check item	Additional information (mechanism of the compressor failure)
1 & 2	The liquid refrigerant return volume to the compressor is controlled by the discharge gas temperature Td when compressor is operating. If Td thermistor is disconnected, the liquid refrigerant return volume will become small by detecting the temperature even if the actual discharge gas temperature is high. Therefore, this abnormal overheating by detecting the temperature operation will result in insulation failure of the motor winding.
3 & 4	Overcurrent control (operating frequency control) is performed by detecting current by the PCB2. In this case, winding insulation failure will occur, since control is not available in spite of actually high current.
5 & 6	The current sensor checks phase and adjusts output electrical wave in addition to the above mentioned items. If fault occurs, the output electrical wave becomes unstable giving stress to the motor winding, resulting in winding insulation failure.
7 & 8	During a cooling operation, SH is controlled by MV of each indoor units. During a heating operation, Td is controlled by MV1. If expansion valves are incorrectly connected, correct control is not available, resulting in compressor seizure depending on liquid refrigerant returning conditions or motor winding insulation failure depending on overheating conditions.
9	If the refrigeration cycle and electrical system are incorrectly connected, abnormally low suction pressure operation is maintained or abnormally high discharge pressure operation is maintained, resulting in giving stress to the compressor, since their correct control is not available.
10	ditto
11	The compressor may be locked due to the liquid return operation during the cooling operation.
12	In the case that the contacting resistance becomes big, voltage imbalance among each phase will cause abnormal overcurrent.
13	In this case, overcurrent will occur, efficiency will decrease or the motor winding will be excessively heated.
14	In the case, it will result in motor burning or compressor seizure.

9 . Spare parts

Index

9.1.	RAS-(2-2.5)HVNP	290
9.1.1.	Cycle and structural parts	290
9.1.2.	Parts table	291
9.2.	RAS-3HVNC.....	292
9.2.1.	Cycle and structural parts	292
9.2.2.	Parts table	293
9.3.	RAS-3HVNPE	294
9.3.1.	Cycle and structural parts	294
9.3.2.	Electrical parts	295
9.3.3.	Parts name	296
9.4.	RAS-(4-6)H(V)NPE	297
9.4.1.	Cycle and structural parts	297
9.4.2.	Electrical parts	298
9.4.3.	Parts name	300
9.5.	RAS-(4-6)H(V)NCE	302
9.5.1.	Cycle and structural parts	302
9.5.2.	Electrical parts	304
9.5.3.	Parts name	306
9.6.	RAS-(8-10)HN(P/C)E	308
9.6.1.	Cycle and structural parts	308
9.6.2.	Electrical parts	310
9.6.3.	Parts name	311
9.7.	RAS-12HN(P/C)	314
9.7.1.	Cycle and structural parts	314
9.7.2.	Electrical parts	315
9.7.3.	Parts name	316

9.1 RAS-(2-2.5)HVNP

9.1.1 Cycle and structural parts

LOCATION OF SPARE PARTS IN THE UNIT

MODEL: RAS-2HVNP
RAS-2.5HVNP

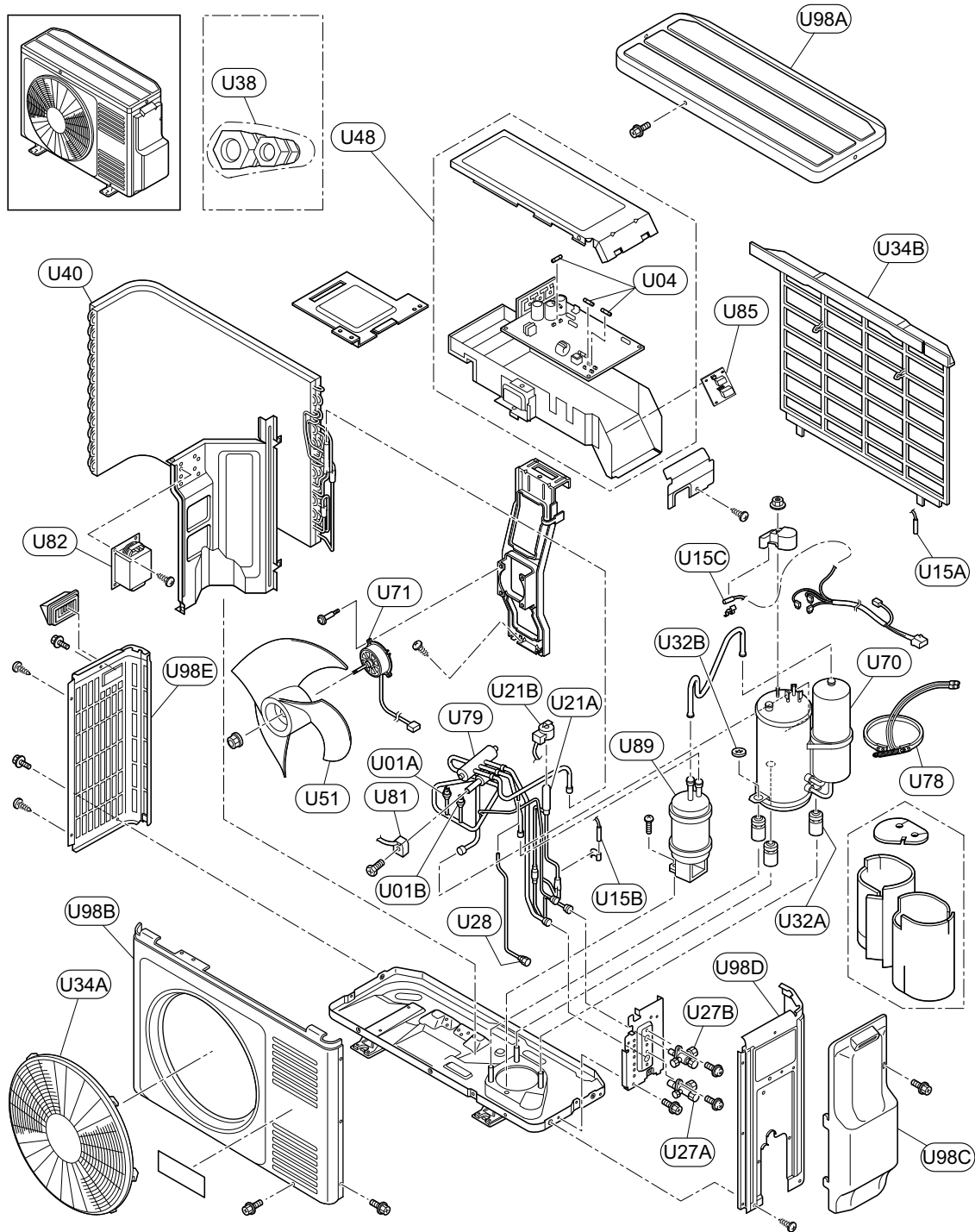

Spare Parts Document: EPN-201212A

9.1.2 Parts table

◆ Cycle and structural parts

No.	Part name	Remarks
U01A	Pressure SW	High pressure
U01B	Pressure SW	For control
U04	Fuse	3A
U15A	Thermistor	Ta
U15B	Thermistor	Te
U15C	Thermistor	Td
U21A	Exp. valve	
U21B	Coil for exp. valve	
U27A	Stop valve	Gas line
U27B	Stop valve	Liquid line
U28	Check joint	
U32A	Vibration absorber	
U32B	Vibration absorber	
U34A	Air grille	Outlet
U34B	Air grille	Inlet
U38	Piping set	
U40	Condenser assembly	
U48	Electrical box ass'y	
U51	Propeller fan	
U70	Compressor	
U71	Motor	
U78	Oil heater	
U79	Four-way valve ass'y	
U81	Coil for 4-way valve	
U82	Reactor	
U85	Printed circuit board	
U89	Accumulator	
U98A	Cabinet panel	
U98B	Cabinet panel	
U98C	Cabinet panel	
U98D	Cabinet panel	
U98E	Cabinet panel	

9.2 RAS-3HVNC

9.2.1 Cycle and structural parts

LOCATION OF SPARE PARTS IN THE UNIT

MODEL: RAS-3HVNC

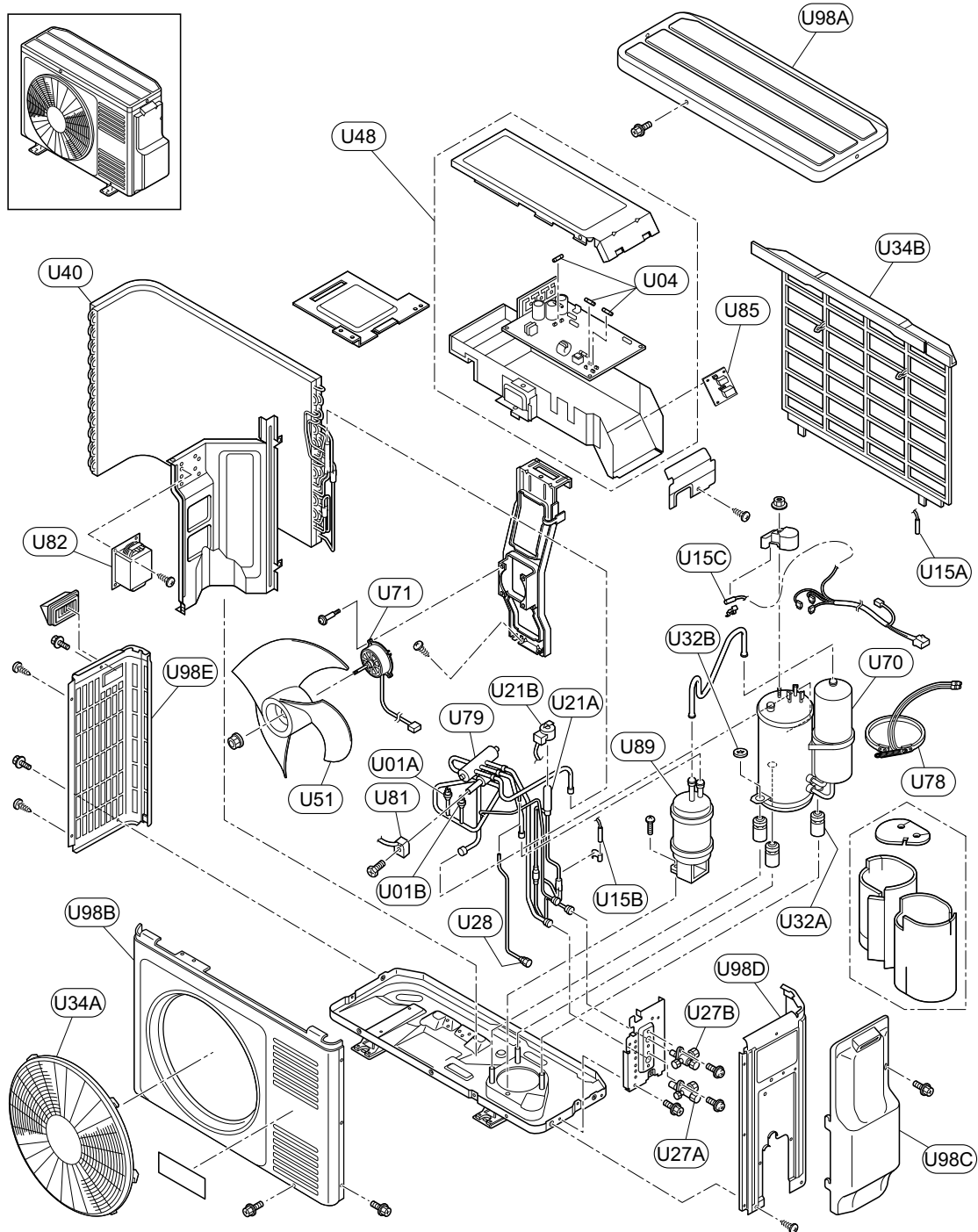

Spare Parts Document: EPN-201212A

9.2.2 Parts table

◆ Cycle and structural parts

No.	Part name	Remarks
U01A	Pressure SW	High pressure
U01B	Pressure SW	For control
U04	Fuse	3A
U15A	Thermistor	Ta
U15B	Thermistor	Te
U15C	Thermistor	Td
U21A	Exp. valve	
U21B	Coil for exp. valve	
U27A	Stop valve	Gas line
U27B	Stop valve	Liquid line
U28	Check joint	
U32A	Vibration absorber	
U32B	Vibration absorber	
U34A	Air grille	Outlet
U34B	Air grille	Inlet
U40	Condenser assembly	
U48	Electrical box ass'y	
U51	Propeller fan	
U70	Compressor	
U71	Motor	
U78	Oil heater	
U79	Four-way valve ass'y	
U81	Coil for 4-way valve	
U82	Reactor	
U85	Printed circuit board	
U89	Accumulator	
U98A	Cabinet panel	
U98B	Cabinet panel	
U98C	Cabinet panel	
U98D	Cabinet panel	
U98E	Cabinet panel	
U98E	Cabinet panel	

9.3 RAS-3HVNP

9.3.1 Cycle and structural parts

LOCATION OF SPARE PART IN THE UNIT CABINET AND CYCLE

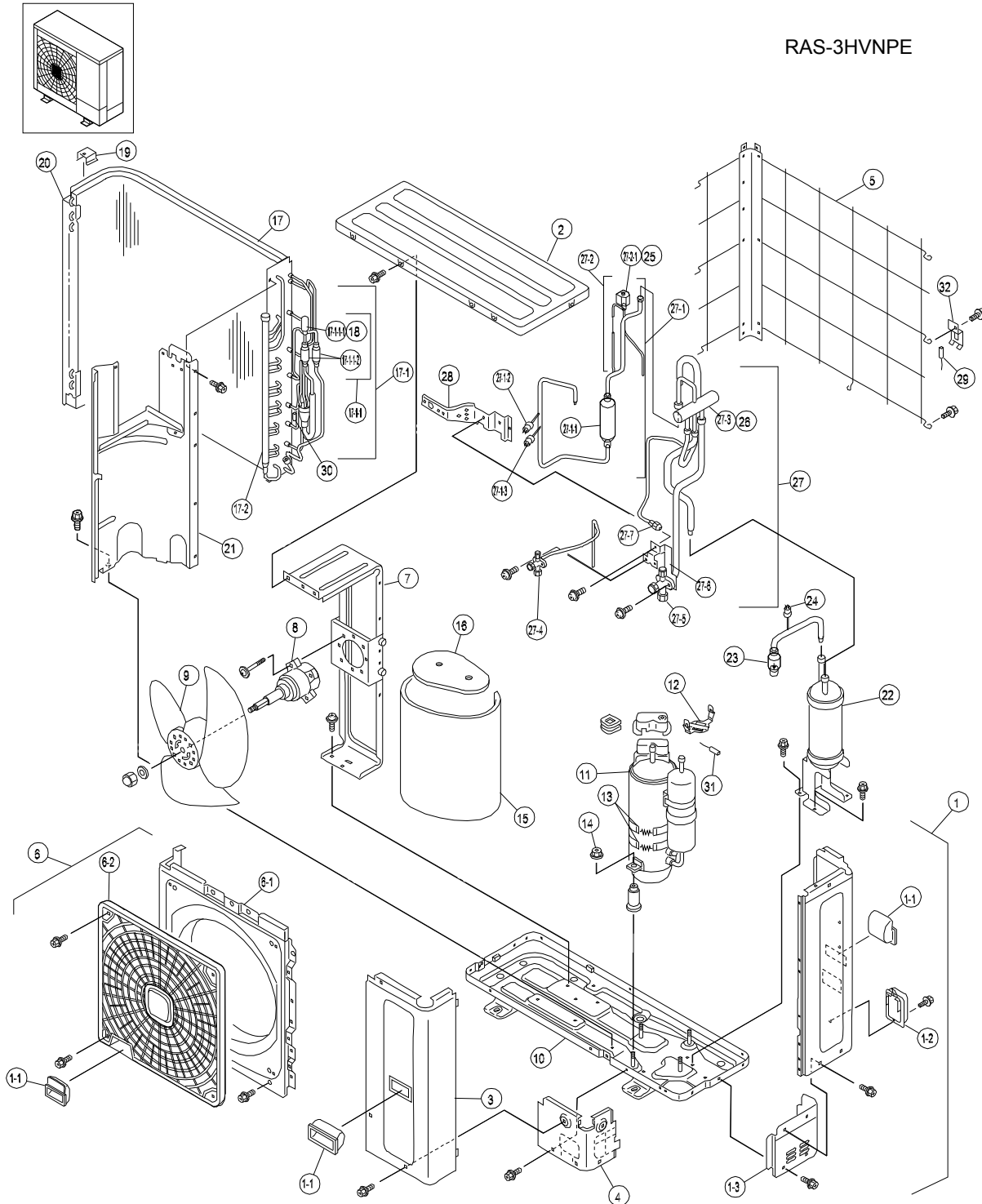

RAS-3HVNP

9.3.2 Electrical parts

LOCATION OF SPARE PART IN THE UNIT ELECTRICAL PARTS

RAS-(3/4/5/6)HVNPE

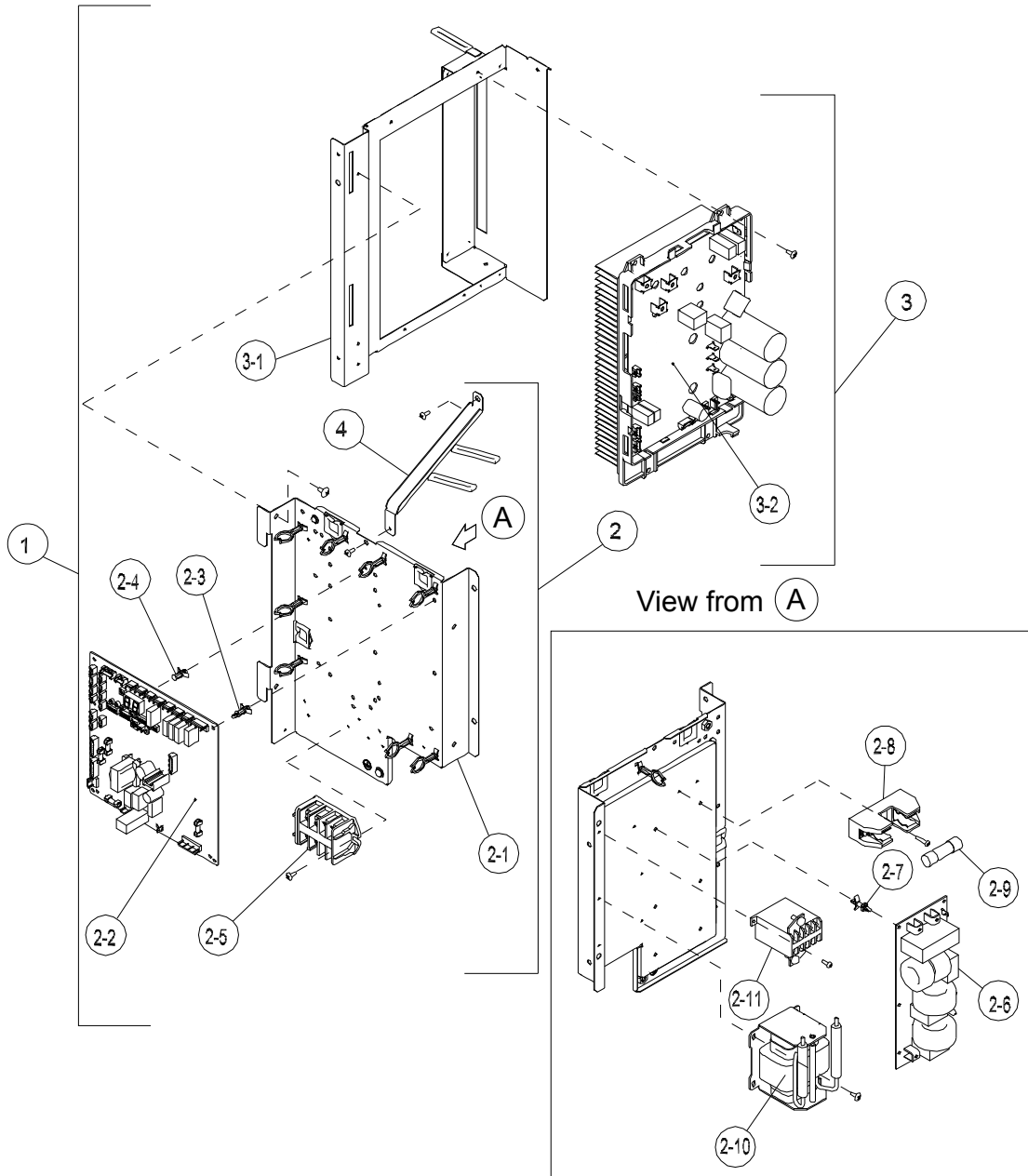

Spare Parts Document: EPN-201211A

9.3.3 Parts name

◆ Cycle and structural parts

No.	Part name	Remarks
1	Rear Cover Assy	Assembly
1-1	Handle	
1-2	H Cover	
1-3	Pipe Cover B	
2	Upper Cover Assy	Assembly
3	Service Cover S Assy	Assembly
4	S Cover B	Lower Service Cover
5	Protector Net S Assy	
6	Shroud S Assy	Assembly
6-1	Shroud S	Shroud
6-2	Front Protector Net	Air Outlet
7	Clamp S Assy	
8	Fan Motor	MOF, DC100W,8P
9	Propeller Fan	Ø544
10	B-Base Assy	Assembly
11	Compressor	DC Comp. 2YC45KXD
12	THM Support D	
13	C Heater	240V-30W
14	Special Nut	
15	Acoustical Cover	
16	Acoustical Cover 1	Upper Cover
17	Condenser	Assembly (Heat exchanger + 17-1+17-2)
17-1	Header G Unit	Assembly
17-2-1	EVO Assy	Assembly
17-2-1-1	Expansion Valve	EVO
17-2-1-2	Strainer	
17-2	Header L Unit	Assembly

No.	Part name	Remarks
18	EXPV Coil	Coil for Expansion Valve
19	Stay	
20	End P Unit	
21	Partition S Assy	
22	Accumulator	
23	Strainer	
24	Pressure SW	for Low Pressure
25	Coil 20	Coil for Solenoid Valve
26	Coil	Coil for 4-Way Valve
27	4-Way Valve Assy	Assembly
27-1	D Pipe Unit	
27-1-1	Silencer	
27-1-2	Pressure SW	PSH (High)
27-1-3	P-Sensor	PSC (Control)
27-2	SVC Assy	
27-2-1	Solenoid Valve	SVA
27-3	4 Way Valve	RVR
27-4	Stop Valve	For liquid line 3/8
27-5	Stop Valve	For gas line 5/8
27-6	Valve Stay	
27-7	Check JA	
28	V-Stay	
29	Thermistor	for Outdoor Temp., THM7
30	Thermistor	for Pipe Temp., THM8
31	Thermistor	for Discharge Gas Temp., THM9
32	TH-Plate	

◆ Electrical parts

No.	Part name	Remarks
1	Electrical Wiring Diagram	Assembly (2+3+Harness)
2	P Plate Unit	Assembly (2-1~2-11)
2-1	P Plate Assy	Assembly
2-2	Printed Circuit Board	PCB1, PO101A Assy
2-3	Spacer	for PCB1
2-4	Push Spacer	for PCB1
2-5	Terminal Board	TB
2-6	Noise Filter	NF
2-7	Spacer	for Noise Filter
2-8	Fuse Holder	
2-9	Fuse	40A
2-10	Reactor Unit	
2-11	MG SW	CMC1
3	Power Unit Assy	Assembly (3-1~3-2)
3-1	Power Stay Assy	Assembly
3-2	Inv. Fin Assy	
4	Upper Support	

9.4 RAS-(4-6)H(V)NPE

9.4.1 Cycle and structural parts

LOCATION OF SPARE PART IN THE UNIT CABINET AND CYCLE

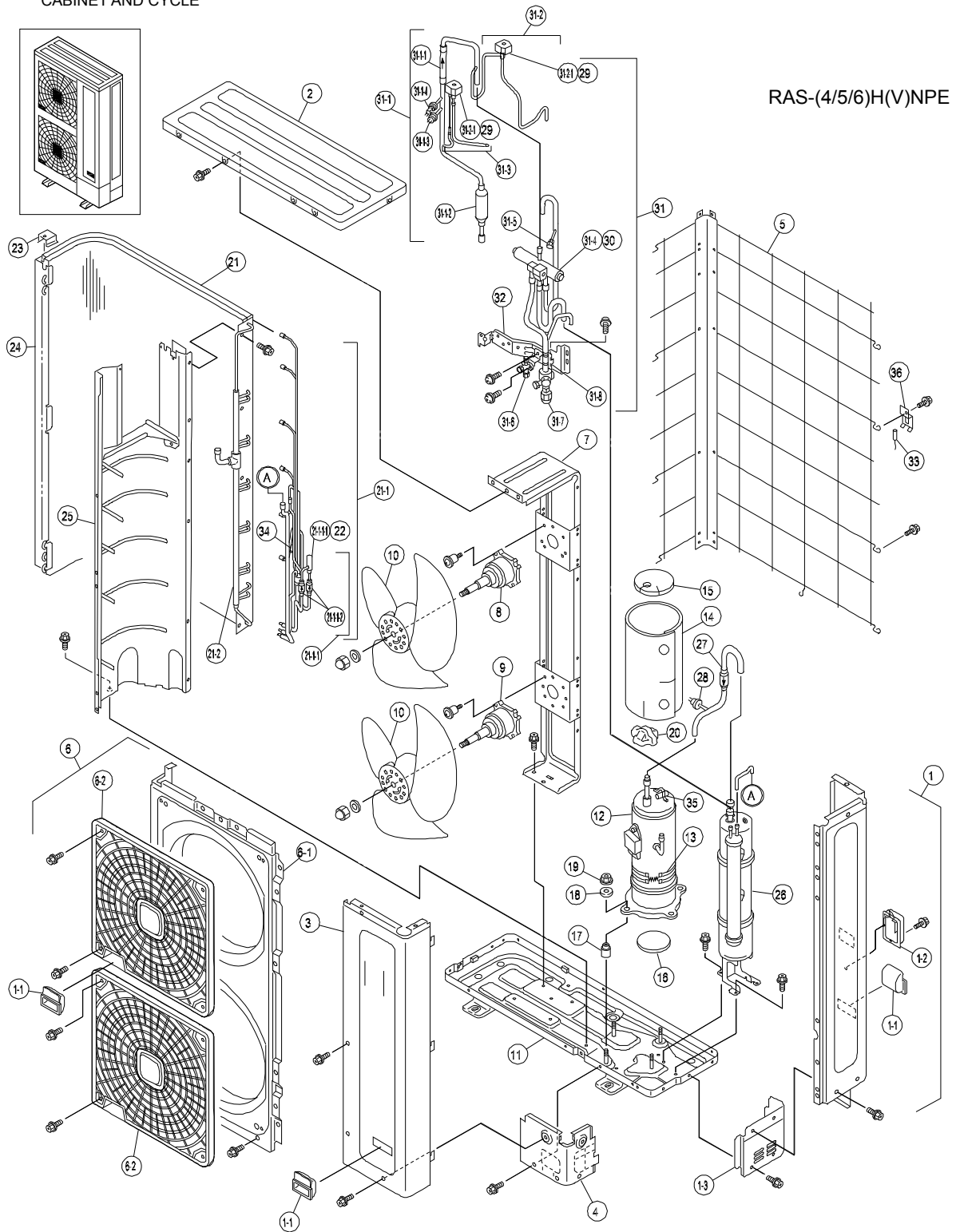

Spare Parts Document: EPN-201211A

9.4.2 Electrical parts

LOCATION OF SPARE PART IN THE UNIT ELECTRICAL PARTS

RAS-(3/4/5/6)HVNPE

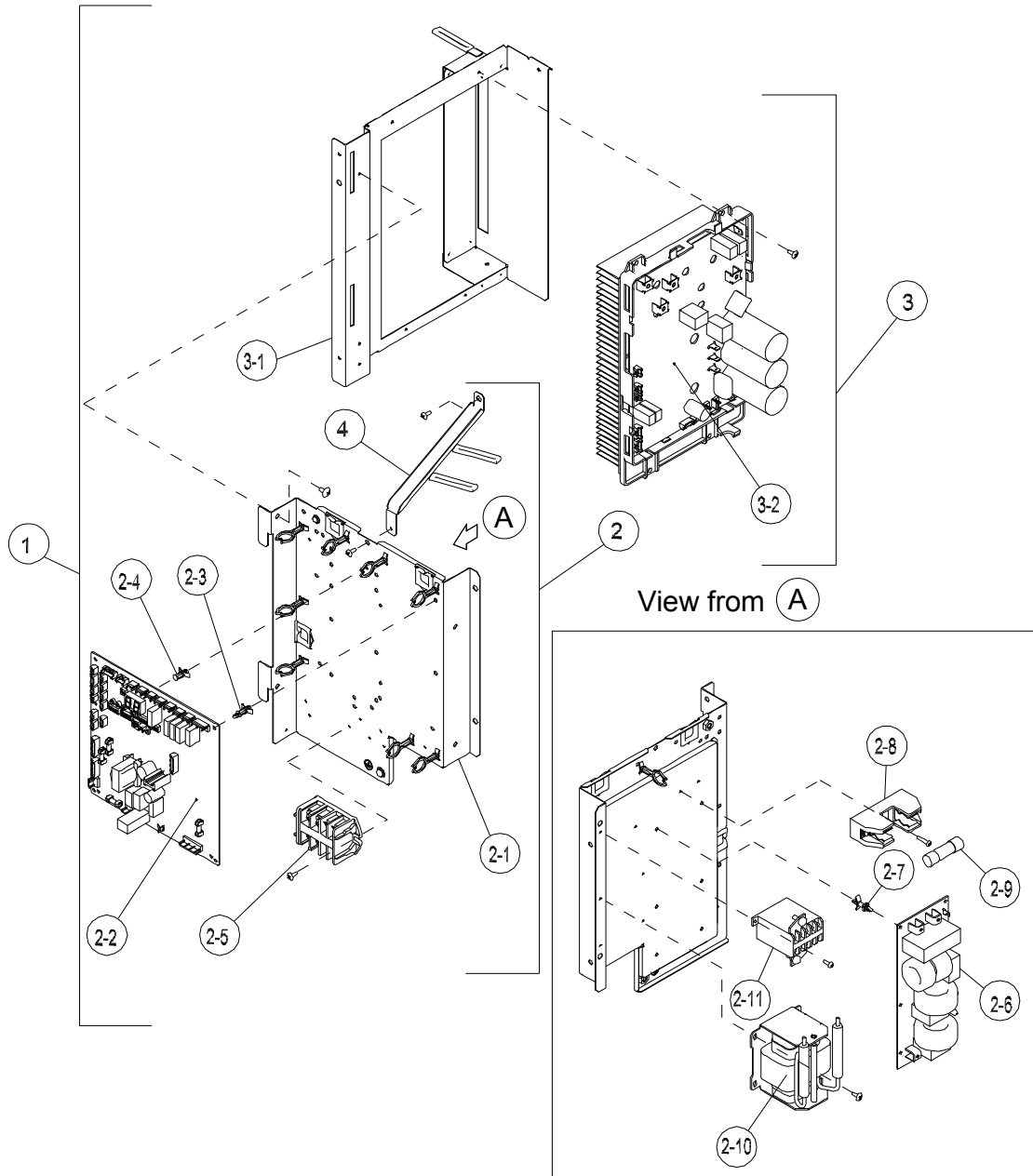

Spare Parts Document: EPN-201211A

LOCATION OF SPARE PART IN THE UNIT

ELECTRICAL PARTS

RAS-(4/5/6)HNPE

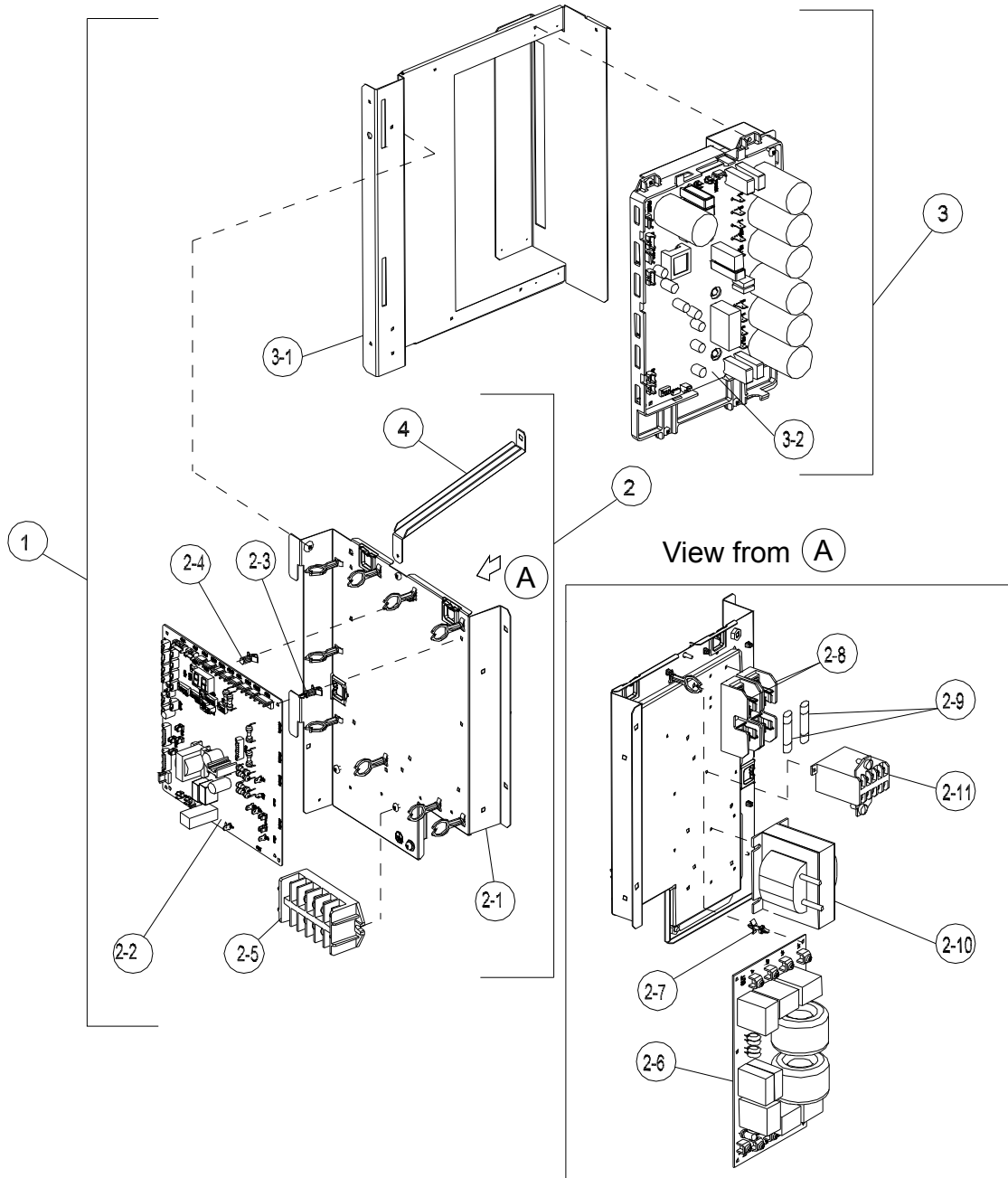

Spare Parts Document: EPN-201211A

9.4.3 Parts name

◆ Cycle and structural parts

No.	Part name	Remarks
1	Rear Cover L Assy	Assembly
1-1	Handle	
1-2	H Cover	
1-3	Pipe Cover B	
2	Upper Cover Assy	Assembly
3	Service Cover L Assy	Assembly
4	S Cover B	Lower Service Cover
5	Protector Net L Assy	
6	Shroud L Unit	Assembly
6-1	Shroud L	Shroud
6-2	Front Protector Net	Air Outlet
7	Clamp L Assy	
8	Fan Motor	MOF1, DC100W,8P
9	Fan Motor	MOF2, DC100W,8P
10	Propeller Fan	Ø544
11	B-Base Assy	Assembly
12	Compressor	E402HHD-36A2 (RAS-(4-6)HVNPE) E402HHD-36D2 (RAS-(4-6)HNPE)
13	C Heater	240V-52W
14	Acoustical Cover	
15	Acoustical Cover	Upper Cover
16	Acoustical Cover	Lower Cover
17	Vibration Absorber	
18	Vibration Absorber	
19	Special Nut	
20	Rubber Cap	
21	Condenser	Assembly(Heat exchanger + 21-1+21-2)
21-1	Header L Unit	Assembly
21-1-1	EVO Assy	Assembly

No.	Part name	Remarks
21-1-1-1	Expansion Valve	EVO
21-1-1-2	Strainer	
21-2	Header G Unit	Assembly
22	EXPV Coil	Coil for Expansion Valve
23	Stay	
24	End P Unit	
25	Partition Assy	
26	Tank Assy	
27	Strainer	
28	Pressure SW	for Low Pressure
29	Coil 20	Coil for Solenoid Valve
30	Coil	Coil for 4-Way Valve
31	4-Way Valve Assy	Assembly
31-1	D Pipe Unit	
31-1-1	Check Valve	
31-1-2	Silencer	
31-1-3	Pressure SW	PSH (High)
31-1-4	P-Sensor	PSC (Control)
31-2	SVC Assy	
31-2-1	Solenoid Valve	SVA
31-3	SVA Assy	
31-4	4 Way Valve	RVR
31-5	Check JA	
31-6	Stop Valve	For liquid line 3/8
31-7	Stop Valve	For gas line 5/8
31-8	Valve Stay	
32	V-Stay	
33	Thermistor	for Outdoor Temp., THM7
34	Thermistor	for Pipe Temp., THM8
35	Thermistor	for Discharge Gas Temp. THM9
36	TH-Plate	

◆ Electrical parts

RAS-(4-6)HVNPE

No.	Part name	Remarks
1	Electrical Wiring Diagram	Assembly (2+3+Harness)
2	P Plate Unit	Assembly (2-1~2-11)
2-1	P Plate Assy	Assembly
2-2	Printed Circuit Board	PCB1, PO101A Assy
2-3	Spacer	for PCB1
2-4	Push Spacer	for PCB1
2-5	Terminal Board	TB
2-6	Noise Filter	NF
2-7	Spacer	for Noise Filter
2-8	Fuse Holder	
2-9	Fuse	50A
2-10	Reactor Unit	
2-11	MG SW	CMC1
3	Power Unit Assy	Assembly (3-1~3-2)
3-1	Power Stay Assy	Assembly
3-2	Inv. Fin Assy	
4	Upper Support	

RAS-(4-6)HNPE

No.	Part name	Remarks
1	Electrical Wiring Diagram	Assembly (2+3+Harness)
2	P Plate Unit	Assembly (2-1~2-11)
2-1	P Plate Assy	Assembly
2-2	Printed Circuit Board	PCB1, PO101B Assy
2-3	Spacer	for PCB1
2-4	Push Spacer	for PCB1
2-5	Terminal Board	TB
2-6	Noise Filter	NF
2-7	Spacer	for Noise Filter
2-8	Fuse Holder	
2-9	Fuse	20A
2-10	Reactor Unit	
2-11	MG SW	Fuji Electric,FC-0/SP
3	Power Unit Assy	Assembly (3-1~3-2)
3-1	Power Stay Assy	Assembly
3-2	Inv. Fin Assy	
4	Upper Support	

9.5 RAS-(4-6)H(V)NCE

9.5.1 Cycle and structural parts

LOCATION OF SPARE PART IN THE UNIT CABINET AND CYCLE

RAS-4H(V)NCE

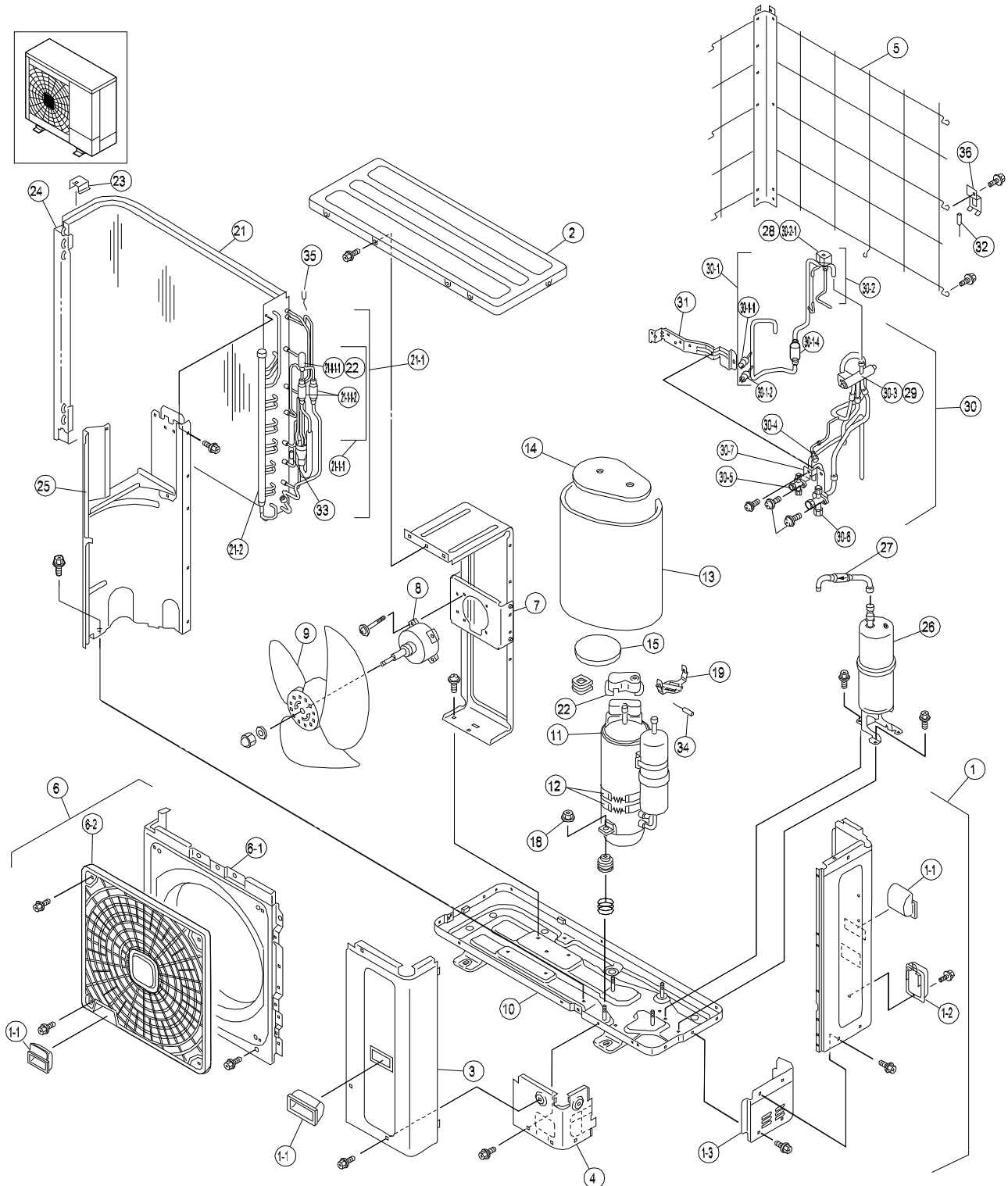

Spare Parts Document: EPN-201211A

LOCATION OF SPARE PART IN THE UNIT

CABINET AND CYCLE

RAS-(5/6)H(V)NCE

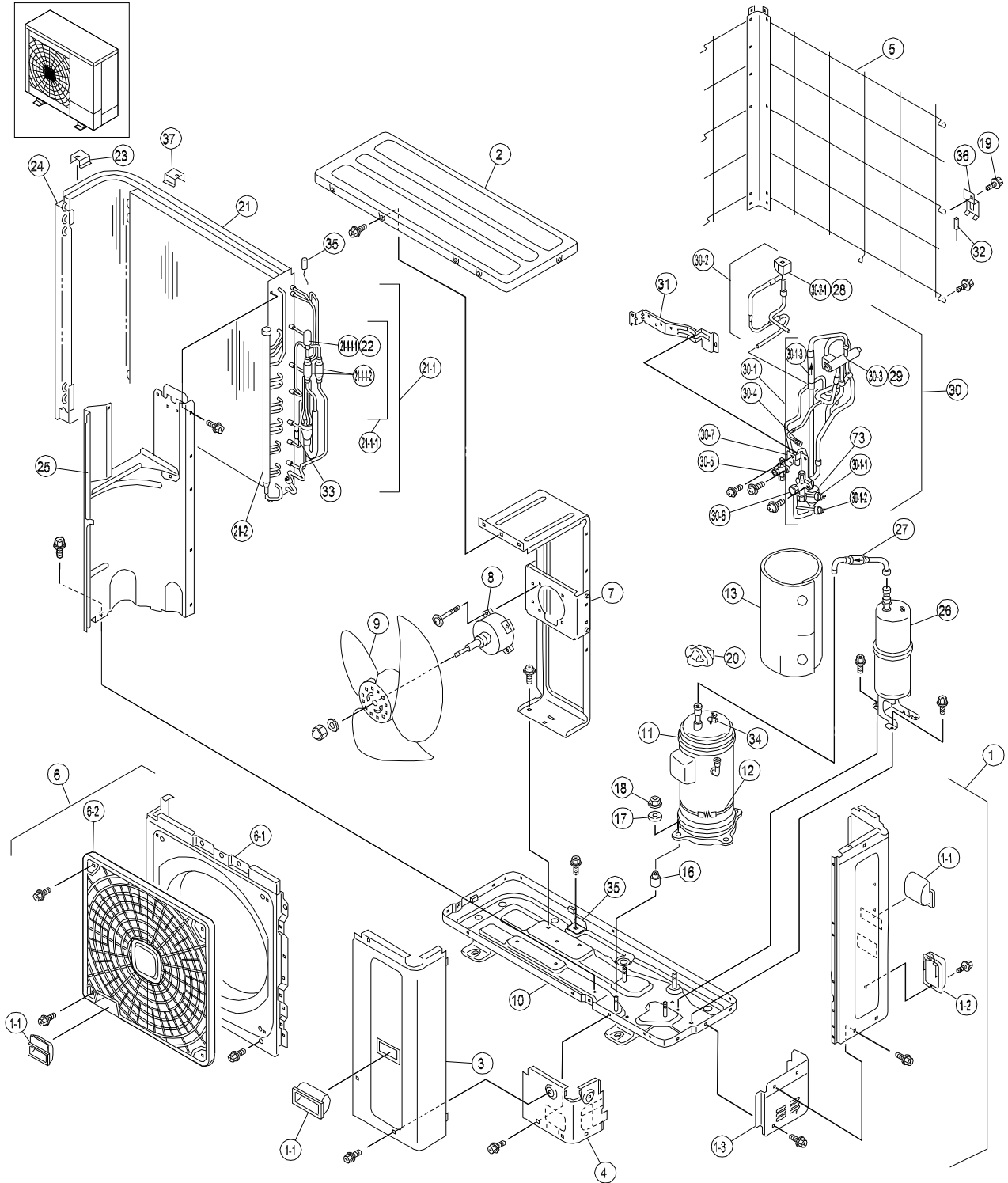

9.5.2 Electrical parts

LOCATION OF SPARE PART IN THE UNIT ELECTRICAL PARTS

RAS-(4/5/6)HVNCE

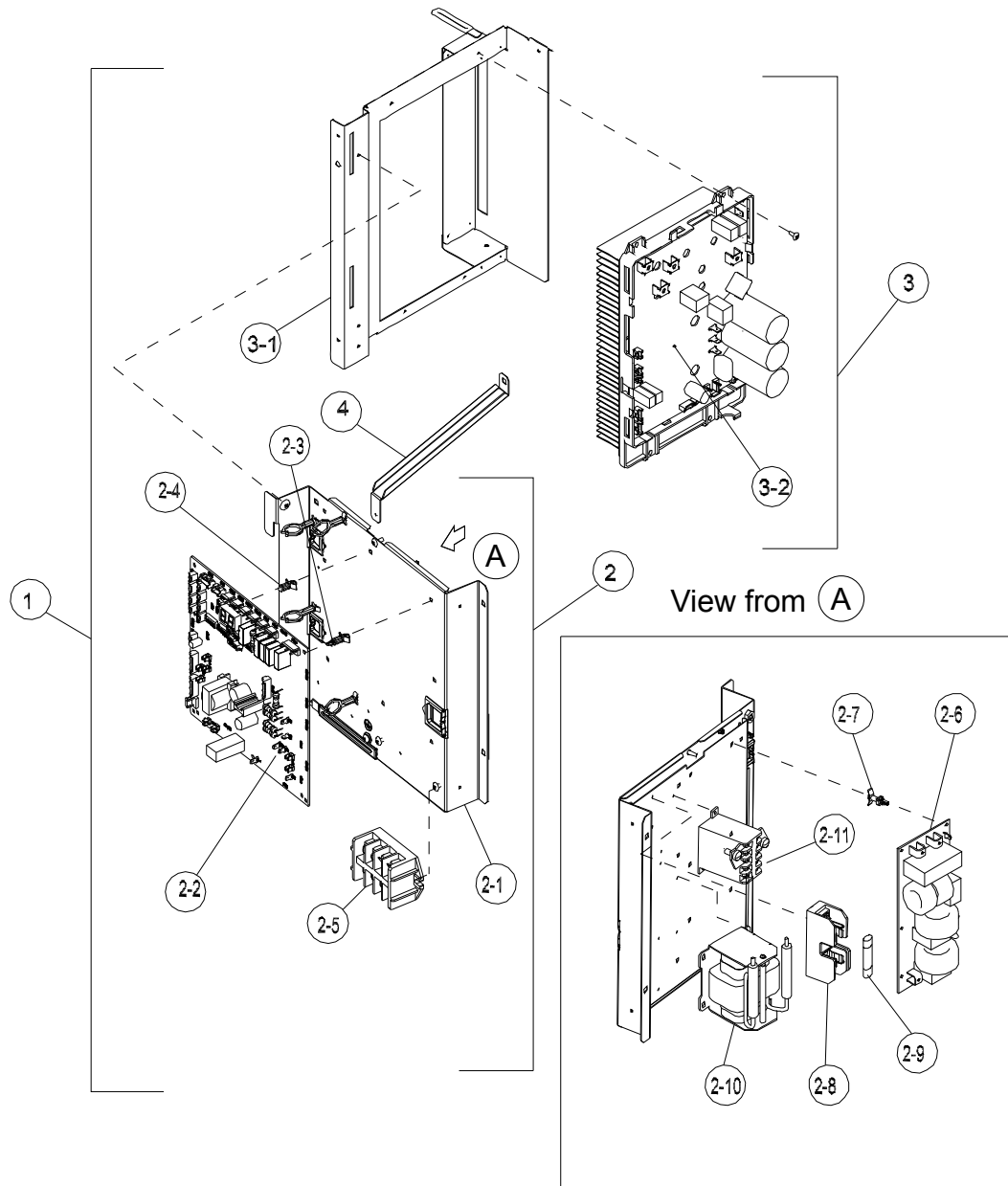

Spare Parts Document: EPN-201211A

LOCATION OF SPARE PART IN THE UNIT

ELECTRICAL PARTS

RAS-(4/5/6)HNCE

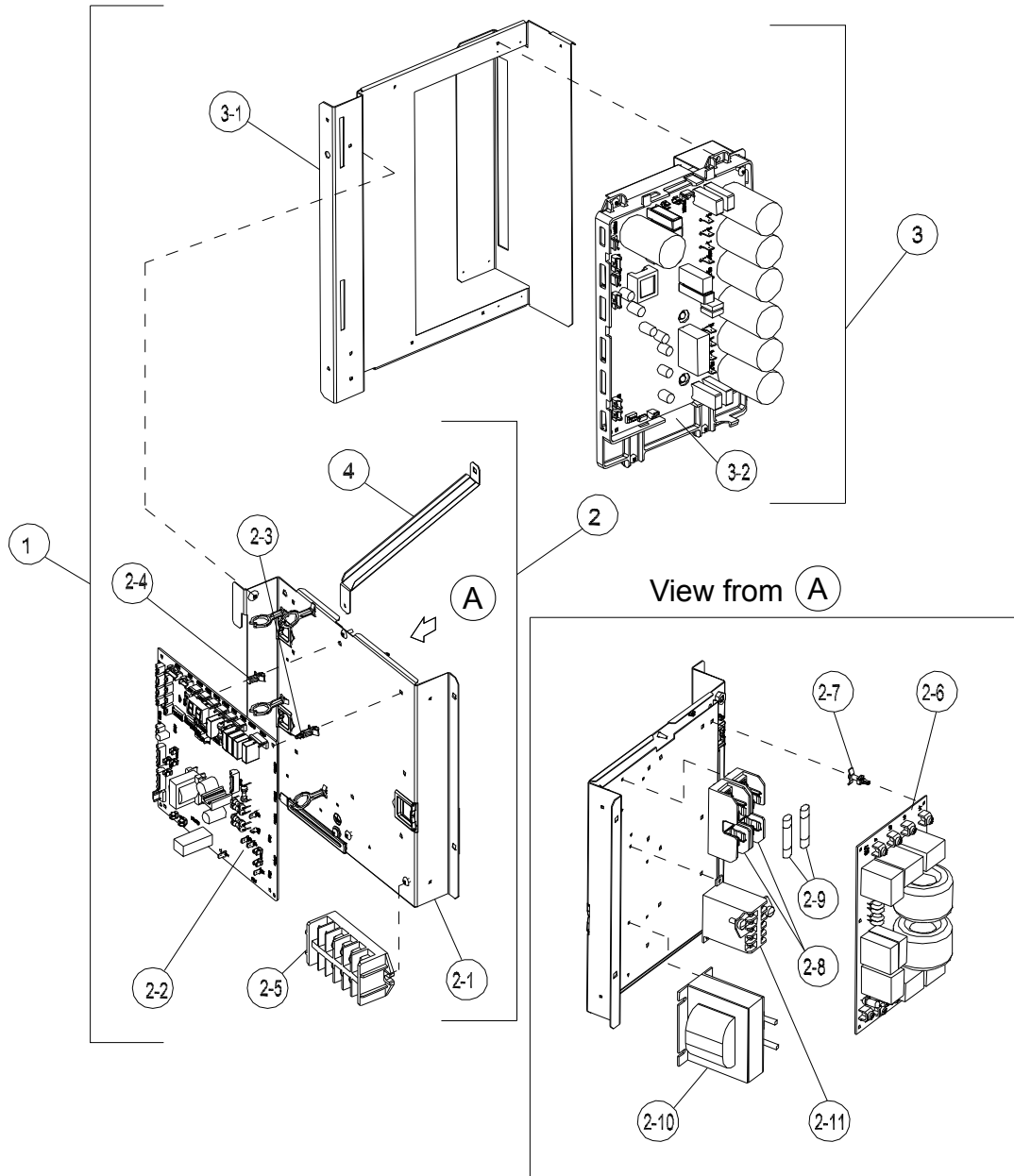

Spare Parts Document: EPN-201211A

9.5.3 Parts name

◆ Cycle and structural parts

No.	Part name	Remarks
1	Rear Cover Assy	Assembly
1-1	Handle	
1-2	H Cover	
1-3	Pipe Cover B	
2	Upper Cover Assy	Assembly
3	Service Cover S Assy	Assembly
4	S Cover B	Lower Service Cover
5	Protector Net S Assy	
6	Shroud S Assy	Assembly
6-1	Shroud S	Shroud
6-2	Front Protector Net	Air Outlet
7	Clamp S Assy	
8	Fan Motor	MOF, DC190W, 8P
9	Propeller Fan	Ø544
10	B-Base Assy	Assembly
11	Compressor	Comp 2YC63FXD (RAS-4HVNCE)
		Comp E401HHD-36A2 (RAS-(5-6)HVNCE)
		Comp 2YC63RXD (RAS-4HNCE)
		Comp E401HHD-36D2 (RAS-(5-6)HNCE)
12	C Heater	240V-30W (RAS-4H(V)NCE)
		240V-52W (RAS-(5-6)H(V)NCE)
13	Acoustical Cover	
14	Acoustical Cover	Upper Cover
15	Acoustical Cover	Lower Cover
16	Vibration Absorber	
17	Vibration Absorber	
18	Special Nut	
19	THM Support D	
20	Rubber Cap	
21	Condenser	Assembly (Heat exchanger + 21-1+21-2)
21-1	Header L Unit	Assembly
21-1-1	EVO Assy	Assembly
21-1-1-1	Expansion Valve	EVO

No.	Part name	Remarks
21-1-1-2	Strainer	
21-2	Header G Unit	Assembly
22	EXPV Coil	Coil for Expansion Valve
23	Stay	
24	End P Unit	
25	Partition S Assy	
26	Accumulator Assy	
27	Strainer	
28	Coil 20	Coil for Solenoid Valve
29	Coil	Coil for 4 Way Valve
30	4-Way Valve Assy	Assembly
30-1	D Pipe Unit	
30-1-1	Pressure SW	PSH (High)
30-1-2	Pressure SW	PSC (Control)
30-1-3	Check Valve	
30-1-4	Silencer	
30-2	SVA Assy	
30-2-1	Solenoid valve	SVA
30-3	4 Way Valve	RVR
30-4	Check JA	
30-5	Stop Valve	For liquid line 3/8
30-6	Stop Valve	For gas line 5/8
30-7	Valve Stay	
31	V-Stay	
32	Thermistor	for Outdoor Temp., THM7
33	Thermistor	for Pipe Temp., THM8
34	Thermistor	for Discharge Gas Temp., THM9
35	Thermistor	for Condenser Temp., THM10
36	TH-Plate	
37	Stay	
31-8	Valve Stay	
32	V-Stay	
33	Thermistor	for Outdoor Temp., THM7
34	Thermistor	for Pipe Temp., THM8
35	Thermistor	for Discharge Gas Temp. THM9
36	TH-Plate	

◆ Electrical parts

RAS-(4-6)HVNCE

No.	Part name	Remarks
1	Electrical Wiring Diagram	Assembly (2+3+Harness)
2	P Plate Unit	Assembly (2-1~2-11)
2-1	P Plate Assy	Assembly
2-2	Printed Circuit Board	PCB1, PO101D Assy
2-3	Spacer	for PCB1
2-4	Push Spacer	for PCB1
2-5	Terminal Board	TB
2-6	Noise Filter	NF
2-7	Spacer	for Noise Filter
2-8	Fuse Holder	
2-9	Fuse	50A (RAS-4HVNCE) 40A (RAS-(5-6)HVNCE)
2-10	Reactor Unit	
2-11	MG SW	CMC1
3	Power Unit Assy	Assembly (3-1~3-2)
3-1	Power Stay Assy	Assembly
3-2	Inv. Fin Assy	
4	Upper Support	

RAS-(4-6)HNCE

No.	Part name	Remarks
1	Electrical Wiring Diagram	Assembly (2+3+Harness)
2	P Plate Unit	Assembly (2-1~2-11)
2-1	P Plate Assy	Assembly
2-2	Printed Circuit Board	PCB1, PO101E Assy
2-3	Spacer	for PCB1
2-4	Push Spacer	for PCB1
2-5	Terminal Board	TB
2-6	Noise Filter	NF
2-7	Spacer	for Noise Filter
2-8	Fuse Holder	
2-9	Fuse	20A
2-10	Reactor Unit	
2-11	MG SW	CMC1
3	Power Unit Assy	Assembly (3-1~3-2)
3-1	Power Stay Assy	Assembly
3-2	Inv. Fin Assy	
4	Upper Support	

9.6 RAS-(8-10)HN(P/C)E

9.6.1 Cycle and structural parts

RAS-(8-10)HNPE

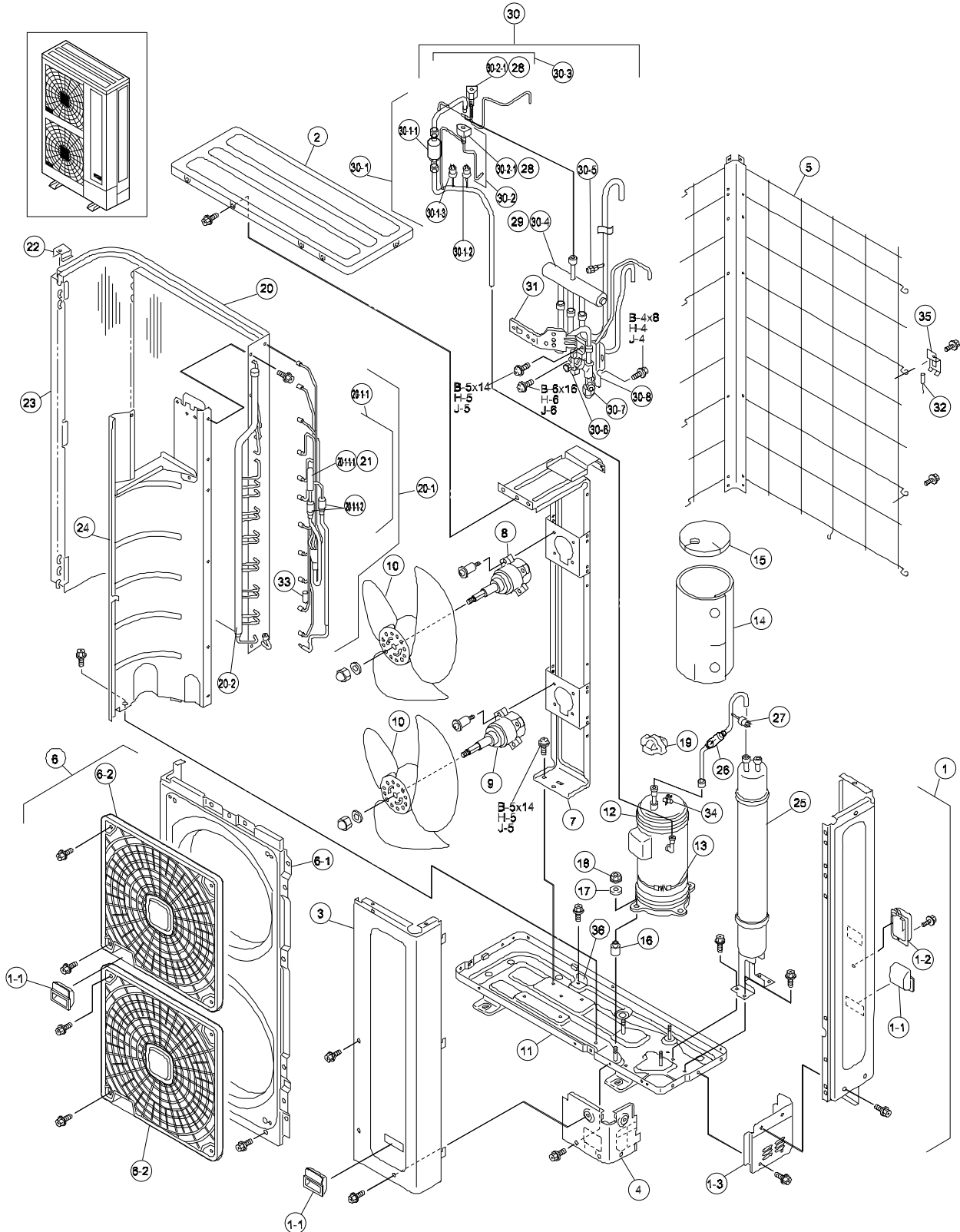

Spare Parts Document: EPN-201211B

RAS-(8-10)HNCE

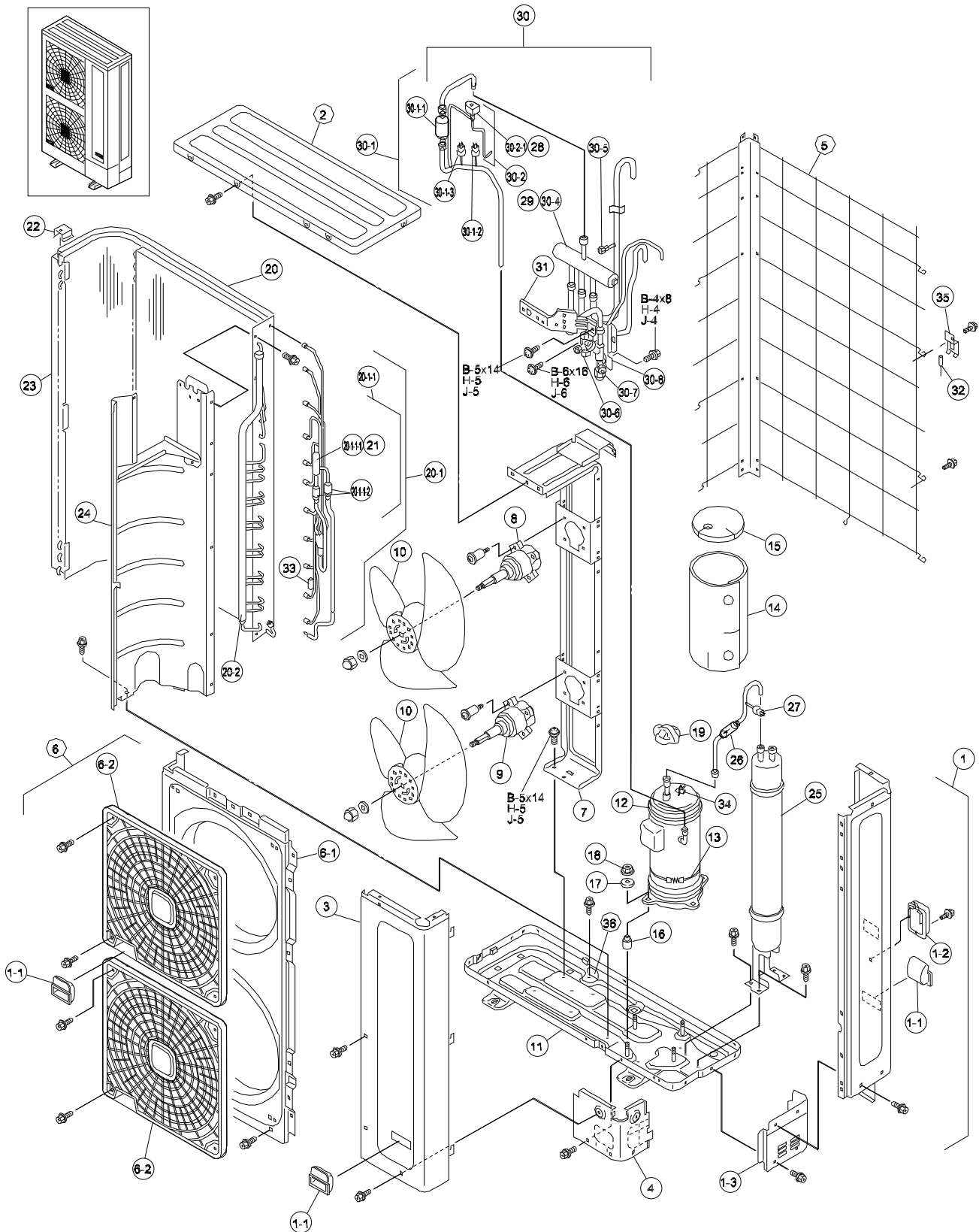

Spare Parts Document: EPN-201211B

9.6.2 Electrical parts

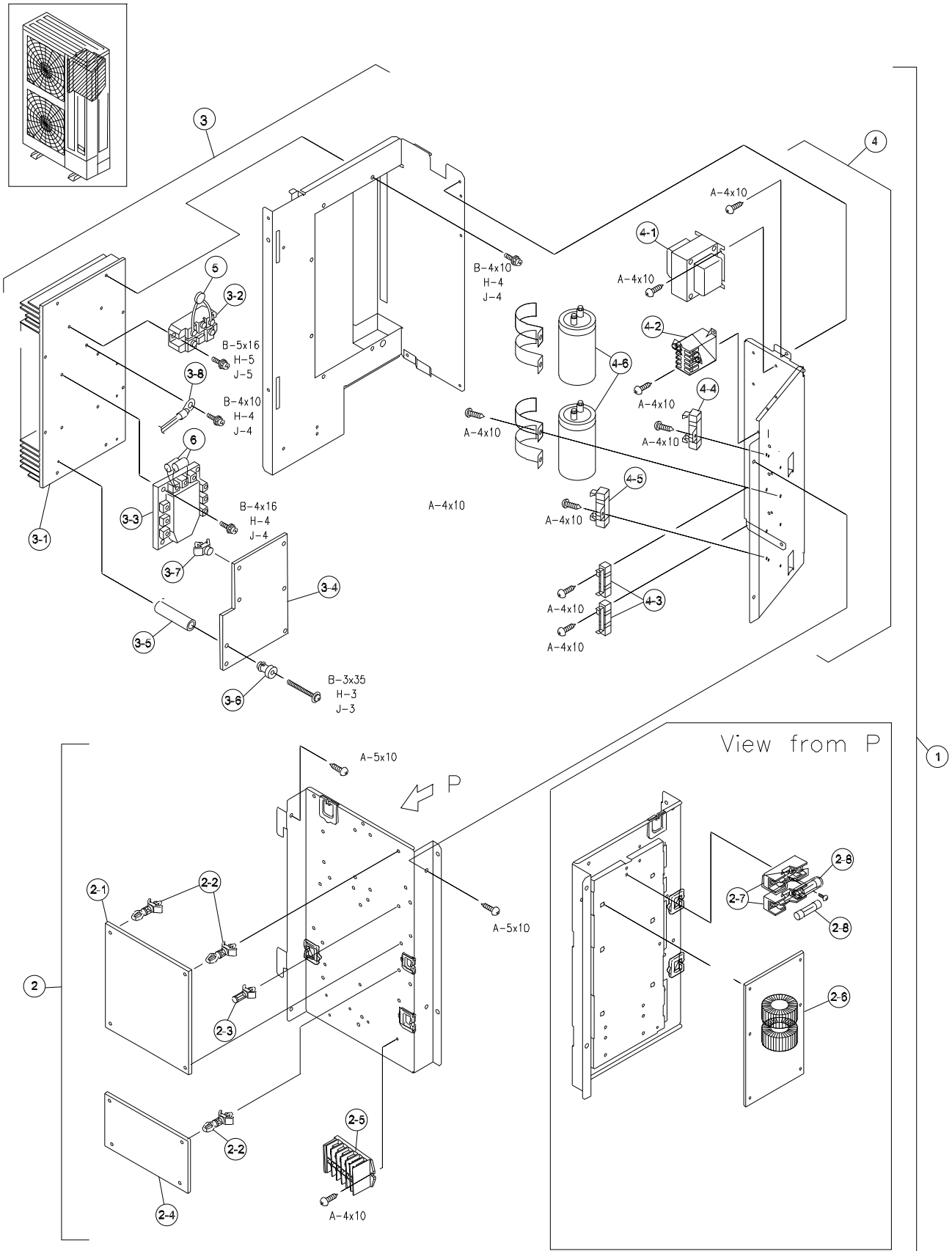

Spare Parts Document: EPN-201211B

9.6.3 Parts name

◆ Cycle and structural parts

RAS-(8-10)HNPE

No.	Part name	Remarks	No.	Part name	Remarks
1	Rear Cover L Assy	Assembly	26	Strainer	
1-1	Handle		27	Pressure SW	
1-2	H Cover		28	Coil 20	Coil for Solenoid Valve
1-3	Pipe Cover B		29	Coil	Coil for 4 Way Valve
2	Upper Cover Assy	Assembly	30	4-Way Valve Assy	Assembly
3	Service Cover L Assy	Assembly	30	4-Way Valve Assy	Assembly
4	S Cover B	Lower Service Cover	30-1	D Pipe Unit	
5	Protector Net L Assy		30-1-1	Check Valve	
6	Shroud L Unit	Assembly	30-1-2	Pressure SW	PSH (High)
6-1	Shroud L	Shroud	30-1-3	P-Sensor	PSC (Control)
6-2	Front Protector Net	Air Outlet	30-2	SVC Assy	
7	Clamp L Assy		30-2-1	Solenoid Valve	SVA
8	Fan Motor	DC138W, 8P	30-3	SVA Assy	
9	Fan Motor	DC138W, 8P	30-4	4 Way Valve	RVR
10	Propeller Fan	Ø544	30-5	Check JA	
11	B-Base Assy	Assembly	30-6	Stop Valve	For liquid line 3/8 (RAS-8HNPE) For liquid line 1/2 (RAS-10HNPE)
12	Compressor	Comp DA50PHD-D1SE2 (RAS-8HNPE) Comp DA65PHD-D1SE2 (RAS-10HNPE)	30-7	B Valve	For gas line 3/4
13	C Heater	240V-40.8W	30-8	Valve Stay	
14	Acoustical Cover		31	V-Stay	
15	Acoustical Cover	Upper Cap	32	Thermistor	for Outdoor Temp., THM7
16	Vibration Absorber		33	Thermistor	for Pipe Temp., THM8
17	Vibration Absorber		34	Thermistor	for Condenser Temp., THM9
18	Special Nut		35	TH-Plate	
19	Rubber Cap		36	Condenser Support	
20	Condenser	Assembly (Heat exchanger + 21-1 + 21-2)			
20-1	Header L Unit	Assembly			
20-1-1	EVO Assy	Assembly			
20-1-1-1	Expansion Valve				
20-1-1-2	Strainer				
20-2	Header G Unit	Assembly			
21	EXPV Coil	Coil for Expansion Valve			
22	Stay				
23	End P Unit				
24	Partition Assy				
25	Accumulator Assy	Assembly			

RAS-(8-10)HNCE

No.	Part name	Remarks	No.	Part name	Remarks
1	Rear Cover L Assy	Assembly	26	Strainer	
1-1	Handle		27	Pressure SW	
1-2	H Cover		28	Coil 20	Coil for Solenoid Valve
1-3	Pipe Cover B		29	Coil	Coil for 4 Way Valve
2	Upper Cover Assy	Assembly	30	4-Way Valve Assy	Assembly
3	Service Cover L Assy	Assembly	30-1	D Pipe Unit	
4	S Cover B	Lower Service Cover	30-1-1	Check Valve	
5	Protector Net L Assy		30-1-2	Pressure SW	PSH (High)
6	Shroud L Unit	Assembly	30-1-3	P-Sensor	PSC (Control)
6-1	Shroud L	Shroud	30-2	SVA Assy	
6-2	Front Protector Net	Air Outlet	30-2-1	Solenoid Valve	SVA
7	Clamp L Assy		30-4	4 Way Valve	
8	Fan Motor	DC138W, 8P	30-5	Check JA	
9	Fan Motor	DC138W, 8P	30-6	Stop Valve	For liquid line 3/8 (RAS-8HNPE) For liquid line 1/2 (RAS-10HNPE)
10	Propeller Fan	Ø544	30-7	B Valve	For gas line 3/4
11	B-Base Assy	Assembly	30-8	Valve Stay	
12	Compressor	Comp DA50PHD-D1SE2 (RAS-8HNPE) Comp DA65PHD-D1SE2 (RAS-10HNPE)	31	V-Stay	
13	C Heater	240V-40.8W	32	Thermistor	for Outdoor Temp., THM7
14	Acoustical Cover		33	Thermistor	for Pipe Temp., THM8
15	Acoustical Cover	Upper Cap	34	Thermistor	for Condenser Temp., THM9
16	Vibration Absorber		35	TH-Plate	
17	Vibration Absorber		36	Condenser Support	
18	Special Nut				
19	Rubber Cap				
20	Condenser	Assembly (Heat exchanger + 21-1 + 21-2)			
20-1	Header L Unit	Assembly			
20-1-1	EVO Assy	Assembly			
20-1-1-1	Expansion Valve				
20-1-1-2	Strainer				
20-2	Header G Unit	Assembly			
21	EXPV Coil	Coil for Expansion Valve			
22	Stay				
23	End P Unit				
24	Partition Assy				
25	Accumulator Assy	Assembly			

◆ Electrical parts

No.	Part name	Remarks
1	Electrical Box	Assembly (2+3+4+Harness)
2	P Plate Assy	Assembly
2-1	Printed Circuit Board	PCB1, PO101B Assy
2-2	Spacer	For PCB1, PCB3, Noise Filter,
2-3	Push Spacer	For PCB1
2-4	Printed Circuit Board	PCB3, PO121A Assy
2-5	Terminal Board	TB
2-6	Noise Filter	NF
2-7	Fuse Holder	
2-8	Fuse	40A
3	Power Unit	Assembly
3-1	Inverter Fin	
3-2	Diode M	DM
3-3	Transistor M	
3-4	Printed Circuit Board	PCB2, PV093 Assy
3-5	Collar	Plastic Material
3-6	Bush	Plastic Material
3-7	Push Spacer	For PCB2
3-8	Thermistor	Fin thermistor
4	CB Stay Assy	Assembly
4-1	Reactor Unit	DCL
4-2	MG SW	CMC
4-3	Resister	RS1, RS2
4-4	Resistor	R1
4-5	Resistor	R2
4-6	Capacitor	CB1, CB2 (450V, 4700 μ F)
5	Noise Suppressor	ZNR Assy
6	Capacitor Assy	HRN PC301

9.7 RAS-12HN(P/C)

9.7.1 Cycle and structural parts

LOCATION OF SERVICE PARTS IN THE UNIT

<Cabinet and Fan>

MODEL: RAS-12HNP
RAS-12HNC

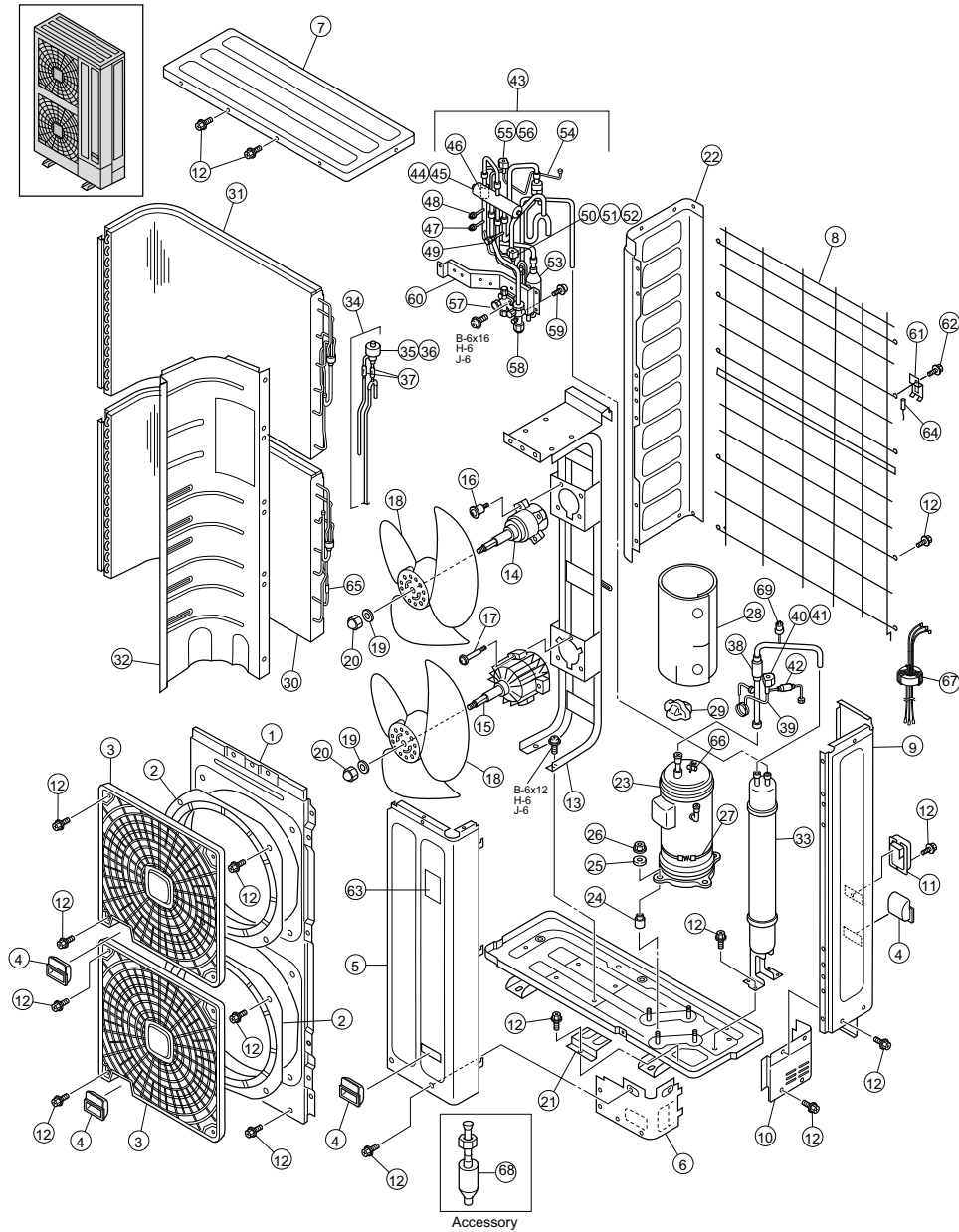

Accessory

A	Truss Head Tapping Screw		F	Stud Bolt	
B	Round Head Screw		G	Nut	
C	Flat Head Screw		H	Washer	
D	Pan Head Tapping Screw		J	Spring Lock Washer	
E	Hexagon Head Bolt		K	Toothed Lock Washer	

NOTE:

The uncoated coating is applied to iron and steel material for the unspecified materials of the bolt and screw.

NOTE:

The parts without order number are the custom-ordered, and these are not mentioned in the price list.

When ordering them, the part name and the drawing number are required.

Contact your HITACHI distributor for the delivery date and price about them.

9.7.2 Electrical parts

LOCATION OF SERVICE PARTS IN THE UNIT

<Electrical Parts> (3φ 400V/50Hz)

MODEL: RAS-12HNP
RAS-12HNC

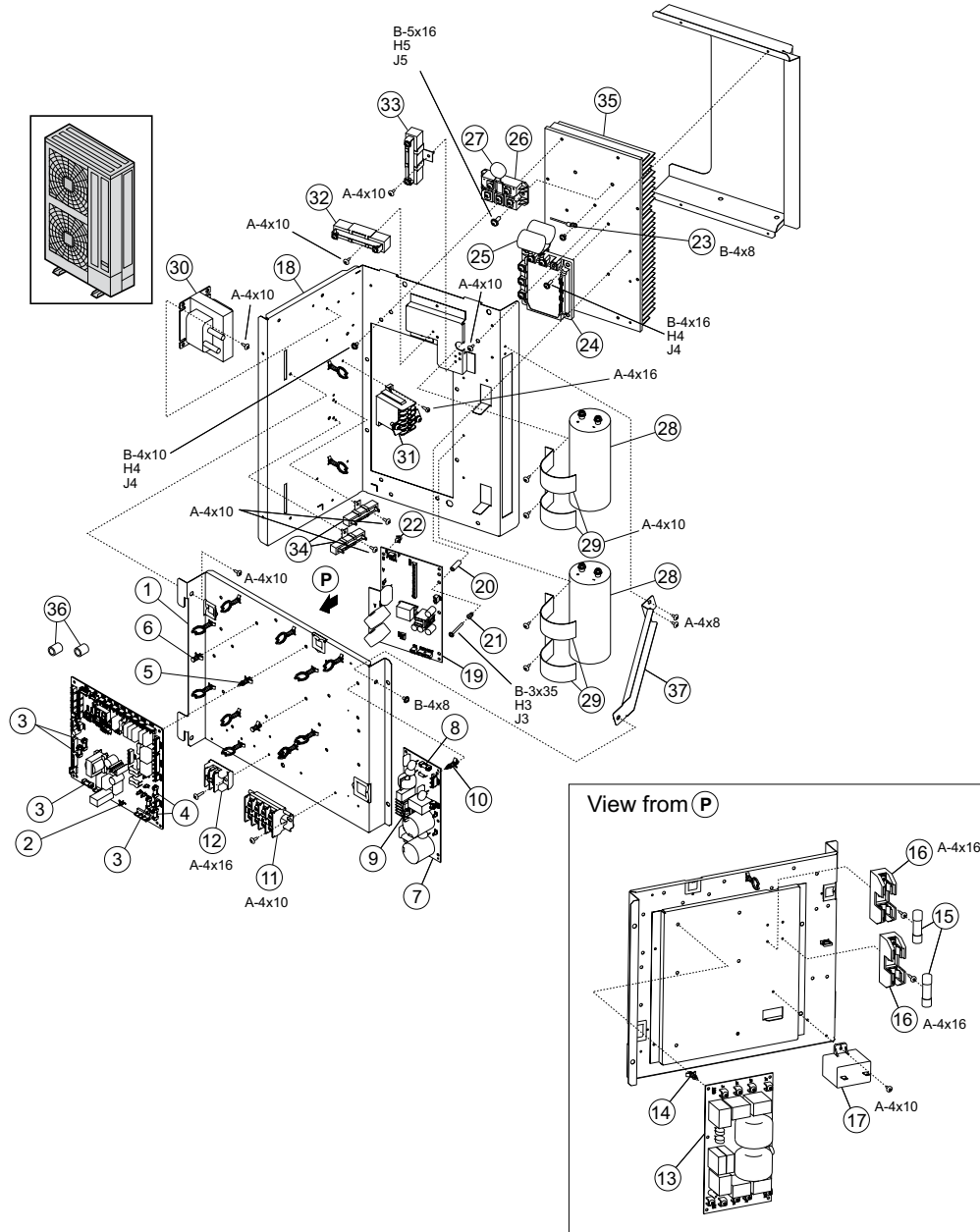

A	Truss Head Tapping Screw		F	Stud Bolt	
B	Round Head Screw		G	Nut	
C	Flat Head Screw		H	Washer	
D	Pan Head Tapping Screw		J	Spring Lock Washer	
E	Hexagon Head Bolt		K	Toothed Lock Washer	

NOTE:
The uncoated coating is applied to iron and steel material for the unspecified materials of the bolt and screw.

NOTE:

The parts without order number are the custom-ordered, and these are not mentioned in the price list. When ordering them, the part name and the drawing number are required. Contact your HITACHI distributor for the delivery date and price about them.

9.7.3 Parts name

◆ Cycle and structural parts

No.	Part name	Remarks
1	Cabinet Panel	Shroud
2	Cabinet Panel	Bell-mouth
3	Air Grille	
4	Handle	
5	Cabinet Panel	Service Cover
6	Cabinet Panel	Lower Service Cover
7	Cabinet Panel	Upper Cover Assy
8	Protection Net	
9	Cabinet Panel	Rear Cover Assy
10	Piping Cover	
11	H-Cover	
12	Screw	M5
13	Motor Clamp	
14	Fan Motor	DC138W, 8P
15	Fan Motor	AC200W, 6P
16	Screw	SUS, M6
17	Screw	SUS, M8
18	Propeller Fan	f544
19	Washer	
20	Closing Nut	
21	Piping Cover	
22	Cabinet Panel	Side Cover
23	Compressor	DA65PHD-D1SE2
24	Vibration Absorber	
25	Vibration Absorber	
26	Nut	
27	Crankcase Heater	240V-40W
28	Soundproof Cover	
29	Rubber Cap	
30	Heat Exchanger	Lower Side
31	Heat Exchanger	Upper Side
32	Partition Plate	
33	Accumulator	
34	Expansion Valve Assy	
35	Expansion Valve	SAGINOMIYA, UKV-32D28
36	Coil	SAGINOMIYA, UKV-U029E
37	Strainer	
38	Strainer	

No.	Part name	Remarks
39	Solenoid Valve Assy	SVF
40	Solenoid Valve	Nichiden Industry, SR10D
41	Coil	Nichiden Industry, SR10D
42	Strainer	
43	Piping Assy	
44	Reversing Valve	SAGINOMIYA, STF-0712G
45	Coil	SAGINOMIYA, VHV-01AP552B1
46	Check Valve	
47	Pressure Switch	for High Pressure Protection, SAGINOMIYA, ACB-DB157
48	Pressure Sensor	for Pd Control, SAGINOMIYA, NSK-BD050D-282
49	Check Joint	
50	Solenoid Valve Assy	SVA
51	Solenoid Valve	Nichiden Industry, SR10D
52	Coil	Nichiden Industry, SR10D
53	Oil Separator	
54	Solenoid Valve Assy	SVC (RAS-12HNP)
55	Solenoid Valve	Nichiden Industry, SR10D (RAS-12HNP)
56	Coil	Nichiden Industry, SR10D (RAS-12HNP)
57	Stop Valve	
58	Stop Valve	
59	Screw	
60	Valve Stay	
61	Thermo Attaching Plate	
62	Screw	M5
63	HITACHI Label	
64	Thermistor	for Outdoor Temp.
65	Thermistor	for Pipe Temp.
66	Thermistor	for Discharge Gas Temp.
67	Wiring Harness	for Compressor
68	Accessory Pipe	
69	Pressure Switch	for Low Pressure, SAGINOMIYA, LCB-DB20

◆ Electrical parts

No.	Part name	Remarks
1	Metal Plate	
2	Printed Circuit Board	for Control (PO101-S)
3	Fuse	on Control PCB, 250V 5A
4	Fuse	on Control PCB, 250V 10A
5	Plastic Material	
6	Plastic Material	
7	Printed Circuit Board	for DC Fan Control (PO121-S)
8	Fuse	on DC Fan Control PCB, 250V 5A
9	Fuse	on DC Fan Control PCB, 250V 1A
10	Plastic Material	
11	Terminal Block	for Power Source
12	Terminal Block	for Transmission
13	Noise Filter	
14	Plastic Material	
15	Fuse	40A
16	Fuse Holder	
17	Capacitor	440V 10 μ F
18	Metal Plate	
19	Printed Circuit Board	for Inverter Control (PV093-S)
20	Plastic Material	
21	Plastic Material	
22	Plastic Material	
23	Thermistor	Inverter Fin
24	Transistor Module	
25	Capacitor Assy	for Noise Suppressor
26	Diode Module	
27	Varistor	
28	Capacitor	450V 4700 μ F
29	Attaching Plate	
30	Reactor	1.0mH
31	Mag. Contactor	
32	Resistor	6.3k Ω
33	Resistor	10.5k Ω
34	Resistor	500 Ω
35	Radiation Fin	
36	Ferrite Core	
37	Stay	

10 . Servicing

Índice

10.1. Introduction.....	323
10.2. Servicing for Outdoor Units RAS-(2-2.5)HVNP and RAS-3HVNC	324
10.2.1. Removing pipe cover	324
10.2.2. Removing front cover	324
10.2.3. Removing outdoor fan	324
10.2.4. Removing the compressor.....	325
10.2.5. Removing high pressure switch and pressure switch for control.....	327
10.2.6. Removing four-way valve coil.....	328
10.2.7. Removing electronic expansion valve coil.....	328
10.2.8. Removing electrical components.....	329
10.3. Servicing for Premium series	332
10.3.1. Outdoor unit RAS-3HVNPE.....	332
10.3.1.1. Removing service cover	332
10.3.1.2. Remove outlet grille.....	332
10.3.1.3. Removing upper cover	333
10.3.1.4. Removing bottom service cover and rear cover.....	333
10.3.1.5. Removing outdoor fan motor	334
10.3.1.6. Removing electrical box	335
10.3.1.7. Removing the compressor	336
10.3.1.8. Removing the High pressure switch and Pressure switch for control	339
10.3.1.9. Opening electrical box (P plate)	340
10.3.1.10. Removing Reversing valve coil	340
10.3.1.11. Removing electronic expansion valve coil.....	341
10.3.1.12. Removing solenoid valve coil (SVC)	341
10.3.1.13. Removing reversing valve	342
10.3.1.14. Removing Electronic expansion Valve and Solenoid Valve.....	343
10.3.1.15. Removing electrical components	343
10.3.1.16. Removing other electrical components	345
10.3.2. Outdoor units RAS-(4-6)H(V)NPE	346
10.3.2.1. Removing service cover	346
10.3.2.2. Removing air outlet grille	346
10.3.2.3. Removing upper cover	347
10.3.2.4. Removing the bottom service cover and rear cover.....	347
10.3.2.5. Removing outdoor fan motor	348
10.3.2.6. Removing electrical box	349

10.3.2.7.	Removing the compressor	350
10.3.2.8.	Removing the High pressure switch and Pressure switch for control	353
10.3.2.9.	Opening electrical box (P plate)	354
10.3.2.10.	Removing Reversing valve coil	354
10.3.2.11.	Removing electronic expansion valve coil.....	355
10.3.2.12.	Removing solenoid valve coil (SVA and SVC).....	355
10.3.2.13.	Removing reversing valve	356
10.3.2.14.	Removing Electronic expansion Valve and Solenoid Valve.....	357
10.3.2.15.	Removing electrical components	358
10.3.2.16.	Removing other electrical components	359
10.3.3.	Outdoor units RAS-(8-10)HNPE.....	360
10.3.3.1.	Removing service cover	360
10.3.3.2.	Removing air outlet grille.....	360
10.3.3.3.	Removing upper cover	361
10.3.3.4.	Removing the bottom service cover and rear cover.....	361
10.3.3.5.	Removing outdoor fan motor.....	362
10.3.3.6.	Removing electrical box	363
10.3.3.7.	Removing the compressor	364
10.3.3.8.	Removing High pressure switch and pressure switch for control.....	367
10.3.3.9.	Opening electrical box (P-Mounting Plate).....	367
10.3.3.10.	Removing reversing valve coil.....	368
10.3.3.11.	Removing electronic expansion valve coil.....	369
10.3.3.12.	Removing solenoid valve coil (SVA and SVC).....	369
10.3.3.13.	Removing reversing valve	370
10.3.3.14.	Removing Electronic expansion Valve and Solenoid Valve.....	371
10.3.3.15.	Removing electrical components	372
10.3.3.16.	Removing other electrical components	374
10.3.4.	Outdoor Units RAS-12HNP	375
10.3.4.1.	Removing service cover	375
10.3.4.2.	Removing air outlet grille.....	375
10.3.4.3.	Removing upper cover	376
10.3.4.4.	Removing the bottom service cover and rear cover.....	376
10.3.4.5.	Removing outdoor fan motor.....	377
10.3.4.6.	Removing electrical box	378
10.3.4.7.	Removing the compressor	379
10.3.4.8.	Removing High pressure switch and pressure switch for control.....	382
10.3.4.9.	Removing reversing and solenoid valves coils.....	383
10.3.4.10.	Removing electronic expansion valve coil.....	384
10.3.4.11.	Removing reversing valve	385
10.3.4.12.	Removing Electronic expansion Valve and Solenoid Valve.....	386
10.3.4.13.	Removing electrical components	388
10.3.4.14.	Removing other electrical components	390

10.4. Servicing for Standard Series.....	391
10.4.1. Outdoor Units RAS-(4-6)H(V)NCE	391
10.4.1.1. Removing service cover	391
10.4.1.2. Remove outlet grille.....	391
10.4.1.3. Removing upper cover	392
10.4.1.4. Removing bottom service cover and rear cover.....	392
10.4.1.5. Removing outdoor fan motor.....	393
10.4.1.6. Removing electrical box	394
10.4.1.7. Removing the compressor	395
10.4.1.8. Removing the High pressure switch and Pressure switch for control	401
10.4.1.9. Opening electrical box (P plate)	402
10.4.1.10. Removing Reversing valve coil	402
10.4.1.11. Removing electronic expansion valve coil.....	403
10.4.1.12. Removing solenoid valve coil (SVA).....	403
10.4.1.13. Removing reversing valve	404
10.4.1.14. Removing Electronic expansion valve and Solenoid valve	405
10.4.1.15. Removing electrical components	405
10.4.1.16. Removing other electrical components	407
10.4.2. Outdoor Units RAS-(8-10)HNCE	408
10.4.2.1. Removing service cover	408
10.4.2.2. Removing air outlet grille.....	408
10.4.2.3. Removing upper cover	409
10.4.2.4. Removing the bottom service cover and rear cover.....	409
10.4.2.5. Removing outdoor fan motor.....	410
10.4.2.6. Removing electrical box	411
10.4.2.7. Removing the compressor	412
10.4.2.8. Removing High pressure switch and pressure switch for control.....	415
10.4.2.9. Opening electrical box (P-Mounting Plate).....	415
10.4.2.10. Removing reversing valve coil.....	416
10.4.2.11. Removing electronic expansion valve coil.....	417
10.4.2.12. Removing solenoid valve coil (SVA).....	417
10.4.2.13. Removing reversing valve	418
10.4.2.14. Removing Electronic expansion Valve and Solenoid Valve.....	419
10.4.2.15. Removing electrical components	420
10.4.2.16. Removing other electrical components	422
10.4.3. Outdoor Units RAS-12HNC	423
10.4.3.1. Removing service cover	423
10.4.3.2. Removing air outlet grille.....	423
10.4.3.3. Removing upper cover	424
10.4.3.4. Removing the bottom service cover and rear cover.....	424
10.4.3.5. Removing outdoor fan motor.....	425
10.4.3.6. Removing electrical box	426

10.4.3.7. Removing High pressure switch and pressure switch for control.....	430
10.4.3.8. Opening electrical box (P-Mounting Plate).....	430
10.4.3.9. Removing reversing and solenoid valves coils.....	431
10.4.3.10. Removing electronic expansion valve coil.....	432
10.4.3.11. Removing reversing valve	433
10.4.3.12. Removing Electronic expansion Valve and Solenoid Valve.....	434
10.4.3.13. Removing electrical components	435
10.4.3.14. Removing other electrical components	437

10.1 Introduction



DANGER

- *Before performing any of the service operations described in this chapter turn all the main switches off and the place security lockers or convenient warning indicators in order to prevent them from turning on accidentally.*
- *In case of blocked or stucked parts use appropriated tools and eventually lubricants to release them.*
- *In case of sharped edged parts as covers use security gloves to avoid getting injured.*
- *When performing brazing work besides security gloves it is must to wear convenient eye protection.*
- *Check and be sure that the LED201 (Red) on the inverter PCB is OFF for all electrical maintenance.*
- *Do NOT touch the electrical components when the LED201 (Red) on the inverter PCB is ON to avoid electrical shock.*



NOTE

- *All compressors are connected by brazing. Check to ensure whether there are flammable things around or not when using a burner for pipe connections if not oil existing pipe inside may ignite.*
- *Do not expose the refrigerant cycle to the atmosphere for a long period in order to avoid mixing the water and foreign particles into the refrigerant cycle. After removing compressor replace it quickly. If exposed for a long period seal the suction pipe and discharge pipe.*
- *Remove the cap for the compressor just before replacing the compressor. Before mounting the compressor seal the suction pipe and discharge pipe with a tape to protect the compressor from foreign particles. Remove the tape at pipe connection.*

10.2 Servicing for Outdoor Units RAS-(2-2.5)HVNP and RAS-3HVNC

10.2.1 Removing pipe cover

Follow the procedure below to remove main parts and components. For mounting follow the reverse procedure of removal.

Do not expose the refrigerant cycle to the atmosphere for a long period to avoid moisture or dust entering into the cycle. Be sure to replace parts immediately after removing. Seal the refrigerant cycle when left unattached for a long period.

- 1 Remove pipe cover downward after removing 1 screw.

1. Pipe cover.

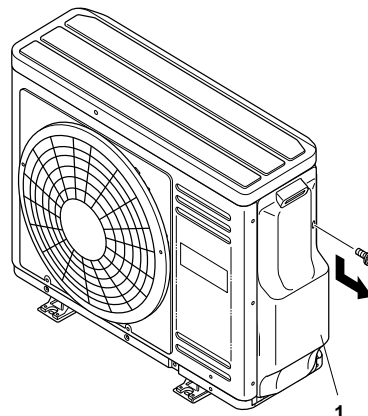

10.2.2 Removing front cover

- 1 Remove the pipe cover following [Removing pipe cover](#).
- 2 Remove 3 fixing screws and remove the upper cover.
- 3 To remove the front cover remove 8 fixing screws and 3 left nails.

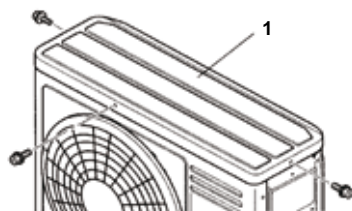

1. Upper cover.

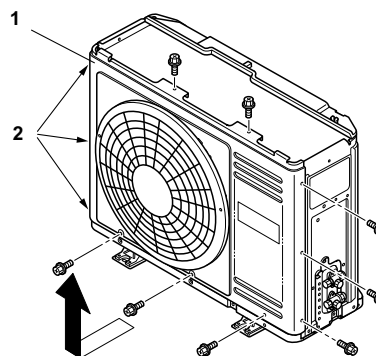

1. Front cover.

2. Nails.

10.2.3 Removing outdoor fan

- 1 Remove the pipe cover following [Removing pipe cover](#).
- 2 Remove 3 fixing screws and remove the upper cover.
- 3 Remove the front cover following [Removing front cover](#).
- 4 To remove the propeller fan remove the cap nut which fixes the propeller fan onto the motor shaft.



NOTE

- Use a puller when the propeller fan and motor shaft are fixed too tightly.
- The cap nut is left thread. For removal turn to the reverse direction to the propeller fan.

- 5 Remove the electrical box cover.
- 6 Remove the fan motor connector (CN24) inserted into the PCB in the electrical box.
Remove the fan motor lead wire fixed onto the motor clamp using a cord band.
Remove 4 screws which fixes the motor.

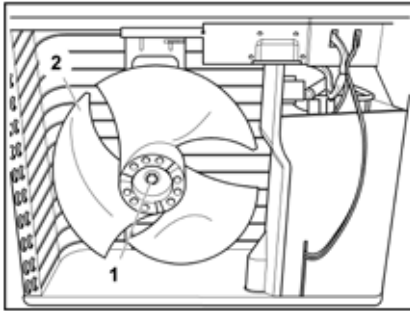

1. Cap nut.
2. Propeller fan.

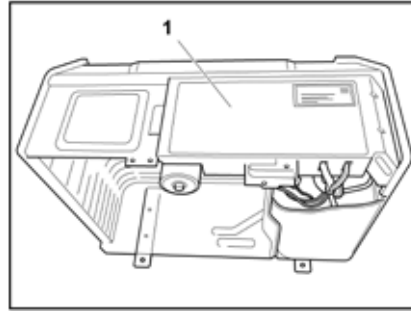

1. Electrical box cover.

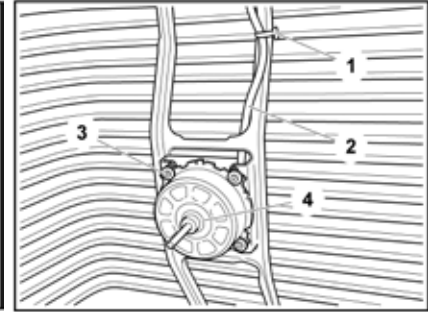

1. Cord band.
2. Fan motor lead wire.
3. Four (4) screws.
4. Fan motor.

**NOTE**

- **To mount the motor be sure to place the lead wire outlet downward.**
- **Fix the motor lead wire onto the motor clamp using a cord band as before to avoid obstructing the propeller fan.**
- **Mounting the propeller fan:**
- **Insert the skidding protection part of the fan boss matching with the motor shaft notch; tighten the nut after the shaft screw fully comes out. (Tightening Torque 3.0 Nm).**
- **Connect the motor lead wire to the electrical box PCB. (To connect insert into the connector (CN24) on the PCB).**

10.2.4 Removing the compressor**NOTE**

- **Do not expose the refrigerant cycle to the atmosphere for a long period to avoid moisture or dust into the cycle. Be sure to replace the compressor immediately after removing. Seal to the suction and discharge pipes when the refrigerant cycle is left unattached for a prolonged time.**
- **Remove the cap of new compressor right before the replacement. Before mounting the compressor seal the suction and discharge pipes with a tape to protect the compressor from dust. Remove the tape at pipe connection.**
- **To connect wiring at reassembling ensure that the compressor terminal numbers and wiring mark band codes are matched. Incorrect wiring numbers may result in inverse rotation and damage the compressor.**

- 1 Remove the pipe cover following [Removing pipe cover](#).
When the outdoor unit is installed close to a wall move the unit from the wall removing the refrigerant piping.
- 2 Collect the refrigerant from the check joint.
- 3 Remove the front cover following [Removing front cover](#).

4 Remove 7 fixing screws and remove the side cover.

1. Electrical box.
2. Heat exchanger.
3. Compressor-top thermistor.
4. Compressor wiring.
5. Terminal cover.
6. Side cover Soundproof cover.

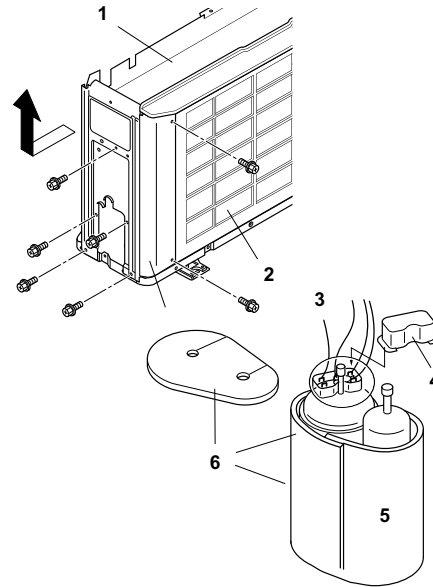
**5** Open the soundproof cover wrapped around the compressor and remove the terminal box cover of the compressor body. Disconnect the compressor wires in the terminal box and remove the thermistor on top of the compressor.

- Check the wiring color and layout when disconnecting. Connecting wires in wrong order at reassembling may result in compressor damage.

1. Compressor-Top Thermistor Mount onto Terminal Cover with Metal Fitting.
2. Yellow.
3. White.
4. Red.
5. Terminal cover.
6. M5 nut.

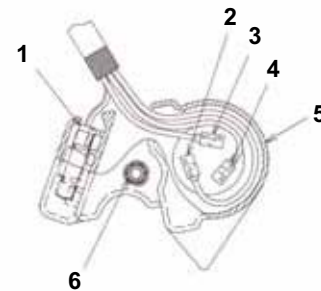
**6** Remove the suction and discharge pipes from the compressor.

- Be sure to separate the blazing burner flame sufficiently from the wires and electrical components around the brazed part in order to avoid burning.

1. Blazing Discharge pipe.
2. Blazing Suction pipe.

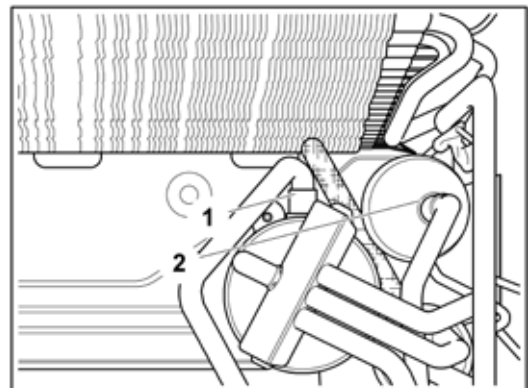

- 7 Remove push nuts A and B which fixes the compressor. Lift the compressor and remove from the unit body. (C in the figure does not have a push nut).
- Check if the Faston terminal has any abnormality when replacing the compressor. (Ensure the pull out force greater than 20 N) If the Faston terminal is identified faulty replace to a new one.
 - Ensure the fixture of the lead wires.

- Compressor.
- Accumulator.
- Push nut.
- Vibration-proof rubber.
- Two push nuts.
- Three vibration-proof rubber.
- Accumulator.

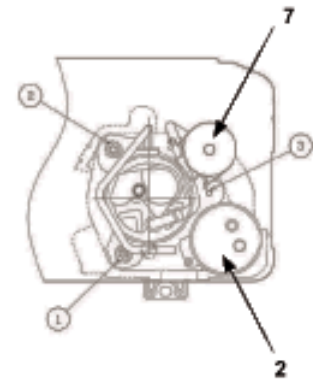
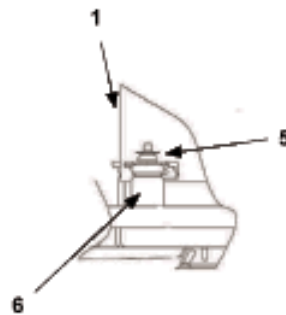
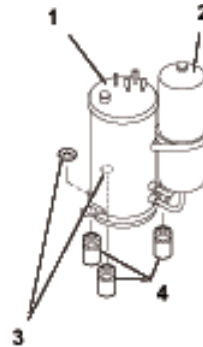

10.2.5 Removing high pressure switch and pressure switch for control

- Remove the pipe cover following [Removing pipe cover](#).
- Remove 3 fixing screws and remove the upper cover.
- Remove the front cover following [Removing front cover](#).
- Collect the refrigerant from the check joint.
- Disconnect the Faston Terminals.
- Remove the high pressure switch and the pressure switch for control from the brazed part of discharge piping.

- High pressure switch.
- Pressure switch for control.
- Brazing.

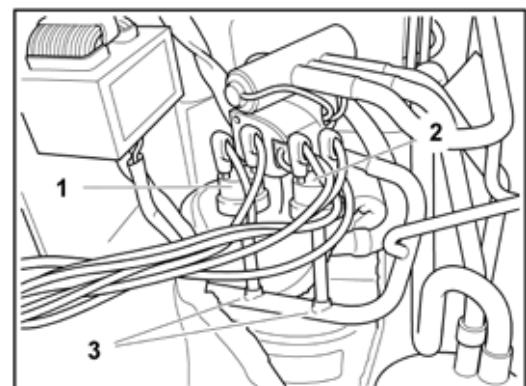

10.2.6 Removing four-way valve coil

- 1 Remove the pipe cover following [Removing pipe cover](#).
- 2 Remove 3 fixing screws and remove the upper cover.
- 3 Remove the front cover following [Removing front cover](#).
- 4 Remove the electrical box cover.
- 5 Disconnect the PCN6 connector on the control PCB of the electrical box.

1: PCN6 Connector (Green)

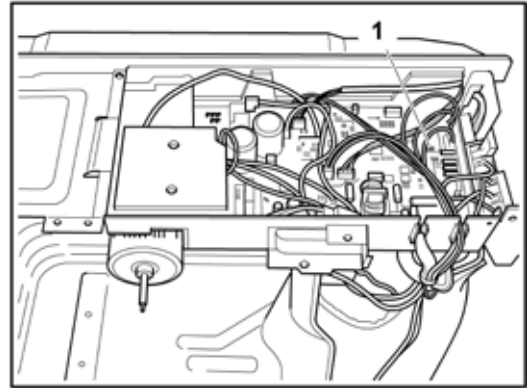

- 6 Remove 1 fixing screw to remove the 4-way valve coil.

1. 4-way valve.
2. 4-way valve coil.
3. Screw.

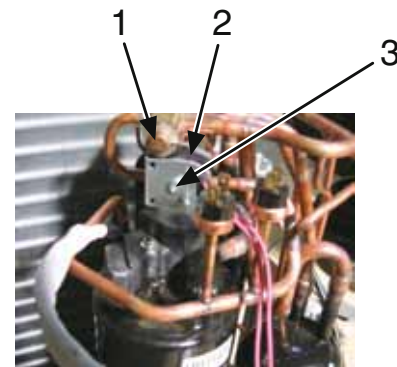

NOTE

DO NOT touch electrical components while the LED1 (Red) is ON to avoid electrical shock. Wait until the LED turns off.

10.2.7 Removing electronic expansion valve coil

- 1 Remove the pipe cover following [Removing pipe cover](#).
- 2 Remove 3 fixing screws and remove the upper cover.
- 3 Remove the front cover following [Removing front cover](#).
- 4 Remove the electrical box cover.
- 5 Remove 7 fixing screws and remove the side cover.
- 6 Remove the CN5A connector on the control PCB of the electrical box.

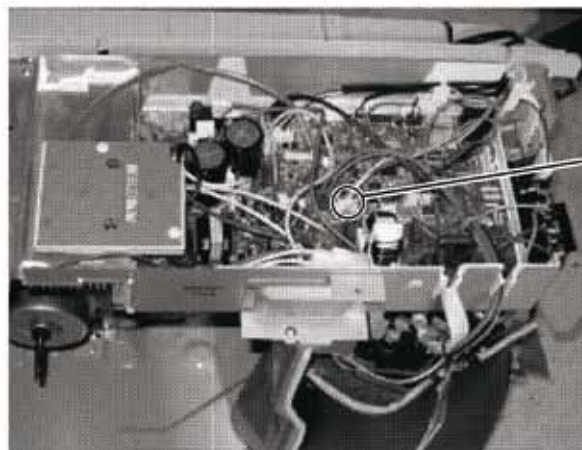

CN5A connector
(white)

- 7 Hold and disconnect the coil of the expansion valve. The expansion valve coil is equipped with a lock mechanism. Ensure that the coil is locked when replacing.

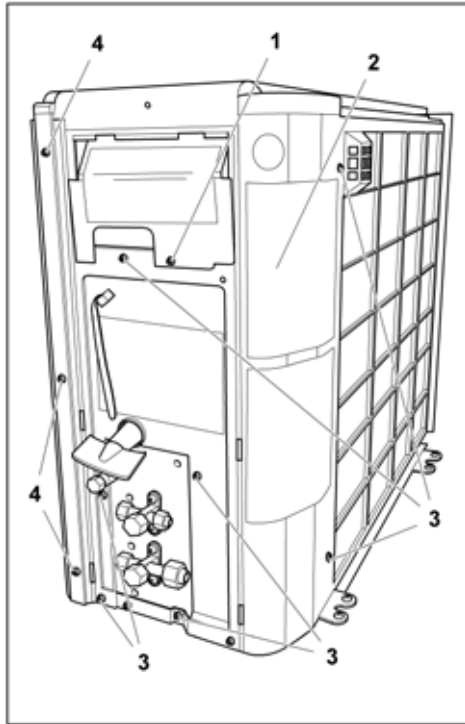

1. One terminal cover screw.
2. Side cover.
3. Seven side cover screws.
4. Three front cover screws.



1. Expansion valve coil.
2. Expansion valve body.

**NOTE**

DO NOT touch electrical components while the LED1 (Red) is ON to avoid electrical shock. Wait until the LED turns off.

10.2.8 Removing electrical components

Removing Electrical Box

- 1 Remove the pipe cover following [Removing pipe cover](#).
- 2 Remove 3 fixing screws and remove the upper cover.
- 3 Remove the electrical box cover.
- 4 Remove 1 fixing screw and remove the terminal cover.
- 5 Disconnect all the wiring connected to the control PCB.
- 6 Remove 2 screws which fix the electrical box.

- 7 Pull up and remove the electrical box.
1. Electrical box cover.
 2. Two screws.

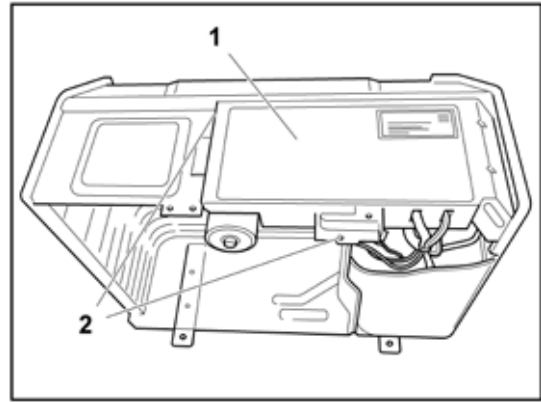

◆ Removing Display PCB

- 1 Remove the pipe cover following [Removing pipe cover](#).
- 2 Remove 1 fixing screw and remove the terminal cover.
- 3 Disconnect all the wiring connected to the display PCB.
- 4 Hold the upper part of 4 holders with long nose pliers and remove the display PCB.

1. Display PCB (PWB2).
2. Terminal cover.
3. Long nose pliers.
4. Display PCB.
5. Holder.

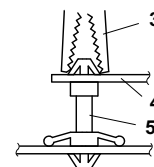
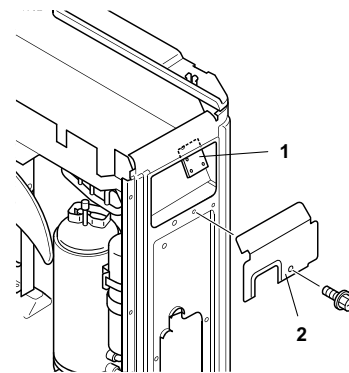

i NOTE

DO NOT touch electrical components on the PCB. Pay attention not to bend or apply much force onto PCB in order to avoid PCB failure.

i NOTE

- 1 **To connect wiring at reassembling ensure that the terminal numbers and wiring mark band codes are matched. Incorrect wiring may result in malfunction or damage of electrical components.**
- 2 **Different dip switch setting shall be applied for each model when the electrical box is replaced; See chapter 8 "Troubleshooting".**
- 3 **Pay attention not to clamp any wiring between plates or electrical components when closing electrical box cover or front cover at reassembling.**

◆ Removing other electrical components

- 1 Remove the pipe cover following [Removing pipe cover](#).
- 2 Remove 3 fixing screws and remove the upper cover.
- 3 Remove the electrical box cover.
- 4 Removing Electrical Components.

Remove the fixing screw and remove the reactor.

- To mount components be sure to match the wiring connection with the mark band codes.

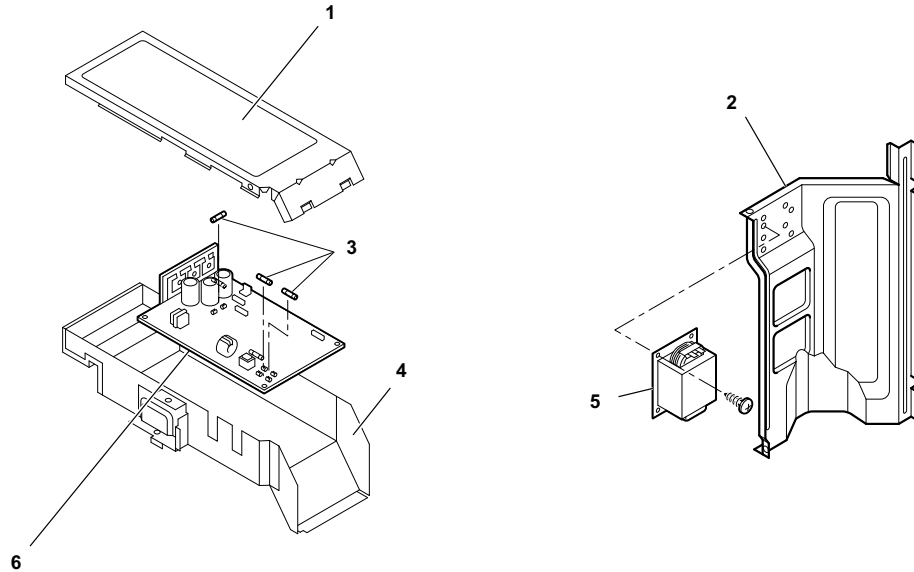

1. Electrical box cover.
2. Partition plate.
3. Fuse.
4. Electrical box.
5. Reactor.
6. See the note.



NOTE

- **The PCB cannot be removed from the electrical box. To replace PCB the entire electrical box must be replaced.**
- **DO NOT touch electrical components while the LED1 (Red) is ON to avoid electrical shock. Wait until the LED turns off.**

10.3 Servicing for Premium series

10.3.1 Outdoor unit RAS-3HVNPE

10.3.1.1 Removing service cover



- *Follow the procedure below to remove main parts and components. For mounting follow the reverse procedure of removal.*
- *Do not expose the refrigerant cycle to the atmosphere for a long period to avoid moisture or dust entering into the cycle. Be sure to replace parts immediately after removing. Seal the refrigerant cycle when left unattached for a long period.*

- 1 Pull downward and remove the service cover after removing 3 upper and lower fixing screws.
 - Pay attention not to drop the service cover.

1. Service cover.

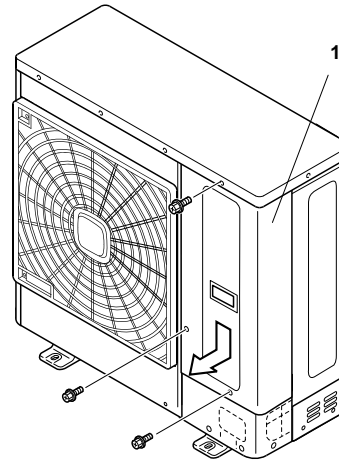

10.3.1.2 Remove outlet grille

- 1 Remove 4 screws which fix the outlet grille.

1. Air outlet grille.
2. Shroud.

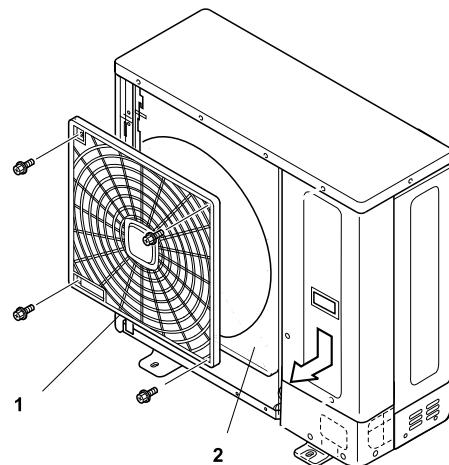

10.3.1.3 Removing upper cover

- 1 Remove the upper cover upward after removing 9 fixing screws.

1. Upper cover.

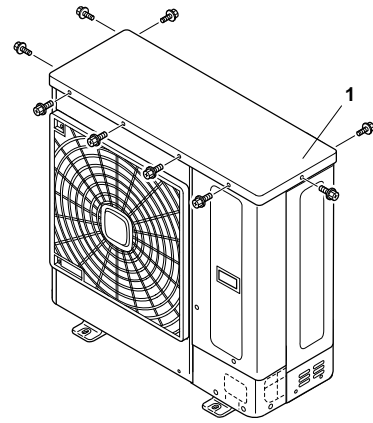
**10.3.1.4 Removing bottom service cover and rear cover**

- 1 Remove 5 screws which fix the bottom service cover. Pull and remove the bottom service cover.
- 2 Remove the upper cover following [Removing upper cover](#).
- 3 Remove 9 screws which fix the rear cover. Pull backward and remove the rear cover.

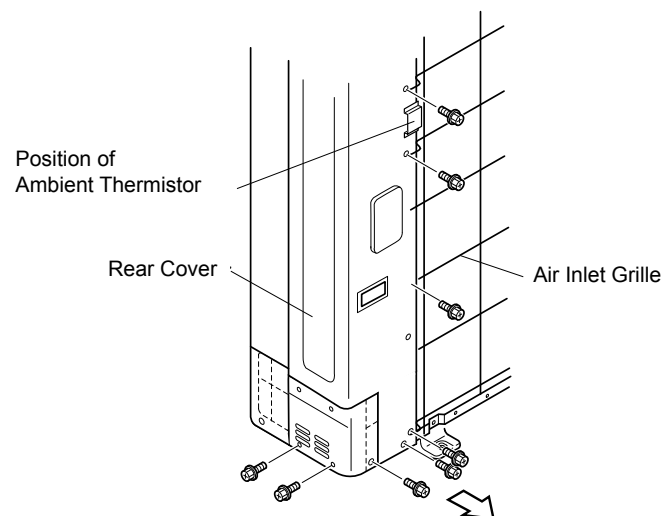
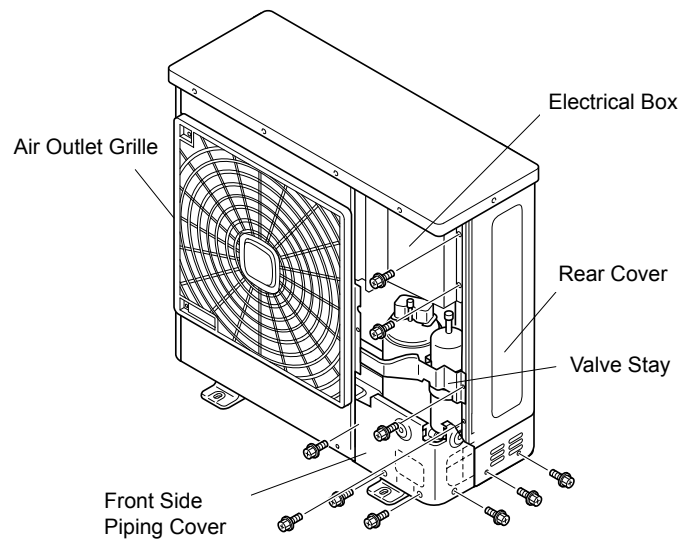
**NOTE**

Pay attention that the screw length for the ambient thermistor differs from other fixing screws.

10.3.1.5 Removing outdoor fan motor

- 1 Remove the service cover following [Removing service cover](#).
- 2 Remove the outlet grille following [Remove outlet grille](#).
- 3 Remove the upper cover following [Removing upper cover](#).
- 4 To remove the propeller fan remove the cap nut and washer which fix the propeller fan onto the motor shaft. (Use a puller when the propeller fan and motor shaft are fixed too tightly).

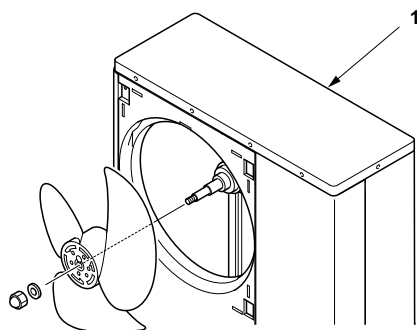

1. Upper cover.

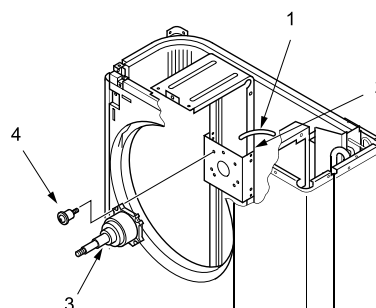

1. Fan motor lead wire.
2. Motor clamp.
3. Motor.
4. Screw with spacer.

- 5 Remove the fan motor connector from PCB in the electrical box.
Cut the plastic tie with nippers which fixes the fan motor lead wire onto the motor clamp.
Remove 4 screws which fix the motor.

Model	RAS-3HVNPE
Connector pin location	Inverter PCB - CN406
Motor fixing screws	4x M5 screws (with spacer)

1. Motor clamp.
2. Plastic tie.
3. Wire.
4. Motor.

i NOTE

- 1 **To mount the motor be sure to place the lead wire outlet downward.**
(Adjust the propeller fan and shroud not to contact with each other).
- 2 **Fix the motor lead wire onto the motor clamp using a plastic tie as shown in the table on the previous page to avoid obstructing the propeller fan.**
- 3 **Mounting propeller fan:**
Insert the skidding protection part of the fan boss matching with the motor shaft notch; tighten the nut after the shaft screw fully comes out. (Tightening Torque 20 Nm)
- 4 **Connect the motor lead wire to PCB1 of the electrical box.**
(Be sure to match colors of the PCB connectors and motor lead wire connectors).
- 5 **Be sure to attach the outlet grill onto the shroud after replacing the fan motor.**

10.3.1.6 Removing electrical box

- 1 Remove the service cover following [Removing service cover](#).
- 2 Remove the upper cover following [Removing upper cover](#).
- 3 Remove 4 screws which fix the electrical box.
- 4 Pull up and remove the electrical box.

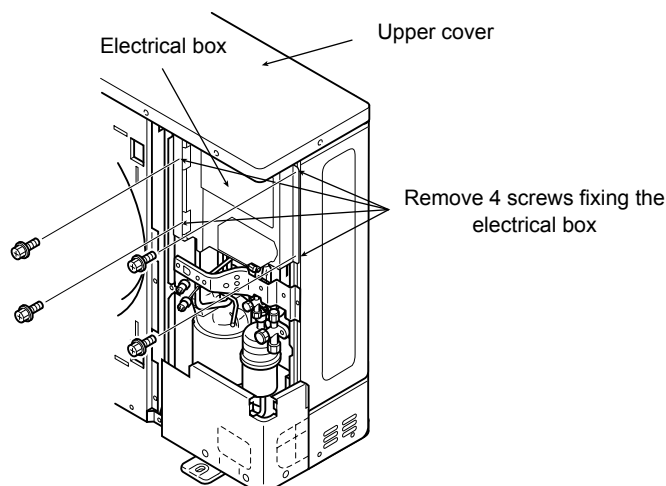

NOTE

The following wiring must be removed to dismount the electrical box.

1. Remove the reversing valve coil from the reversing valve. : [Removing reversing valve coil](#).
2. Remove the expansion valve coil from the expansion valve. : [Removing electronic expansion valve coil](#).
3. Remove the solenoid valve coil from the solenoid valve. : [Removing solenoid valve coil](#).
4. Remove the Faston terminals of high/low pressure switch and the pressure switch for control from the switch body : [Removing the high pressure switch, low pressure switch and pressure switch for control](#).
5. Remove all connectors on the control PCB.
6. Remove the compressor wires in the terminal box of the compressor.
7. To remount the electrical box attach the electrical box fitting with the partition plate.
(Insert the radiation fin into the U-notch on the partition plate and place the fin on the fan box side. Then attach the electrical box hooking onto the partition plate).



Original position

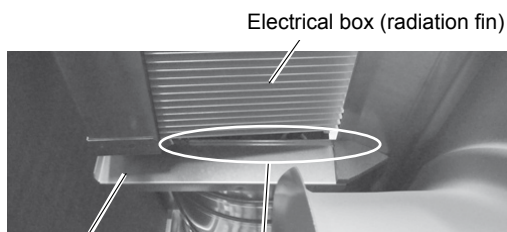
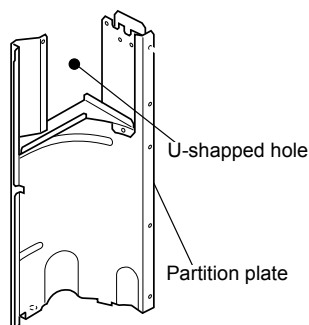

Partition plate

Place the electrical box (radiation fin) in front of the partition plate.
(Refer to the original position)

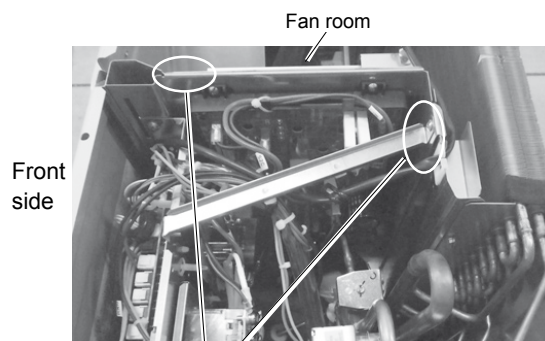

Place the electrical box to hook the parts onto the partition plate.

10.3.1.7 Removing the compressor

- 1 Remove the service cover upper cover bottom service cover and rear cover following *Removing service cover*, *Removing upper cover*, and *Removing bottom service cover and rear cover*. When the outdoor unit is installed close to a wall remove the refrigerant piping and move the unit from the wall.
- 2 Remove the electrical box following *Removing electrical box*.
- 3 Collect the refrigerant from the check joint.
- 4 Remove the valve stay.

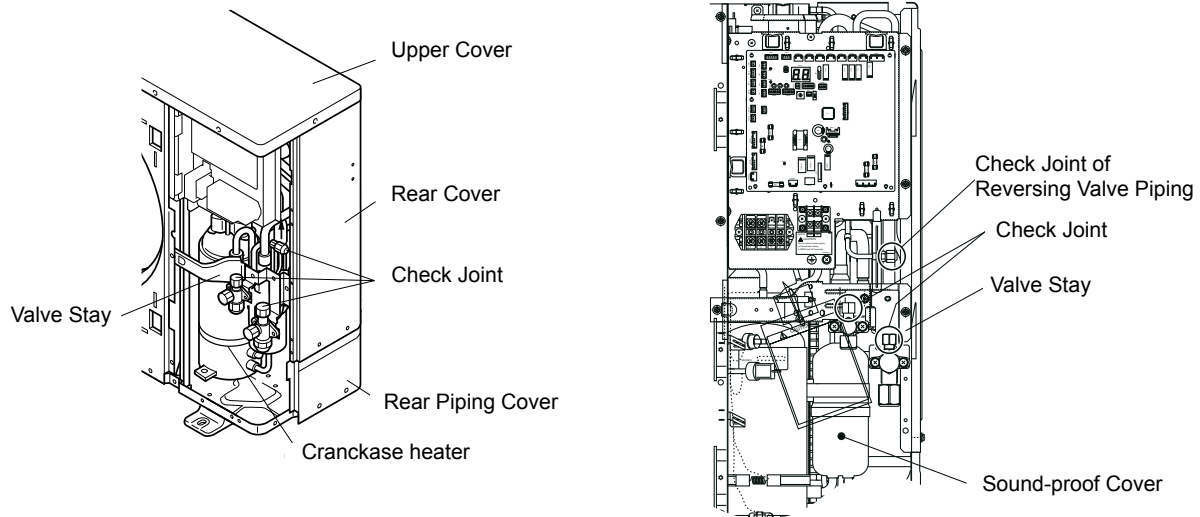

i NOTE

Check Perform the recovery work at the check joint of piping. If not, the refrigerant remains inside.

- 5 Open the soundproof cover wrapped around the compressor and remove the terminal box cover of the compressor body. Disconnect the compressor wires in the terminal box and remove the thermistor on top of the compressor. Remove the soundproof cover.

i NOTE

Check the terminal codes and mark bands when disconnecting the wires. Connecting wires in wrong order at reassembling may result in compressor damage.

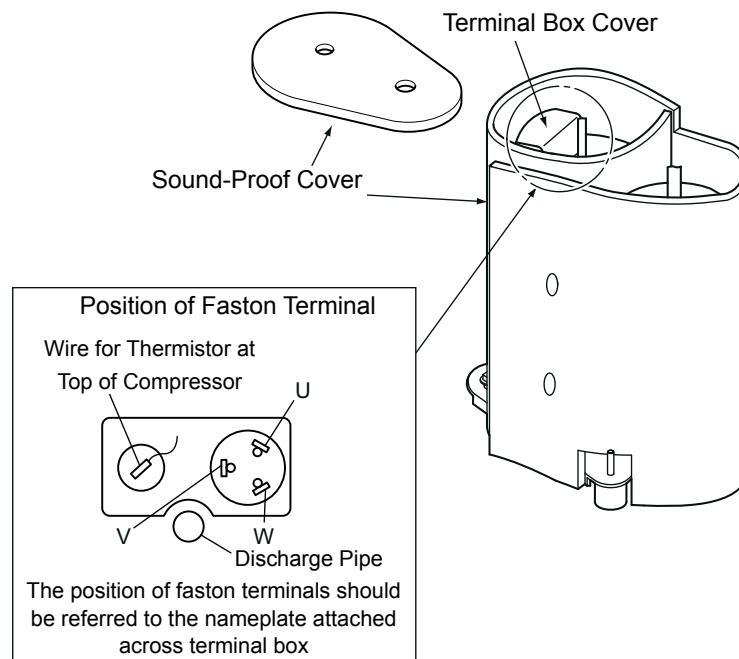

- 6 Remove the crankcase heater.
- 7 Remove the suction pipe and discharge pipe from the compressor. Remove the brazing part after cutting the pipes at "A" by a pipe cutter.

i NOTE

Be sure to separate the blazing burner flame sufficiently from the wires and electrical components around the brazed part in order to avoid burning.

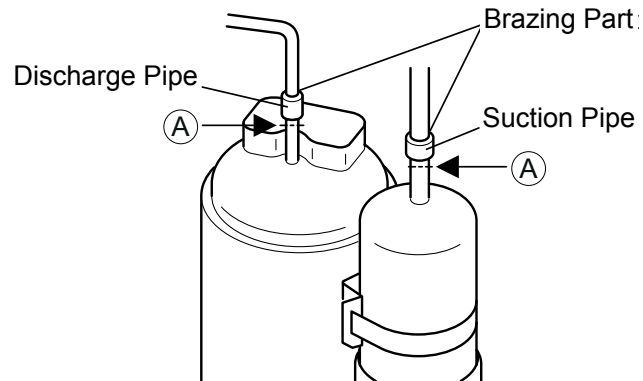

- 8 Remove 1 nut which fix the compressor and remove it by lifting up.

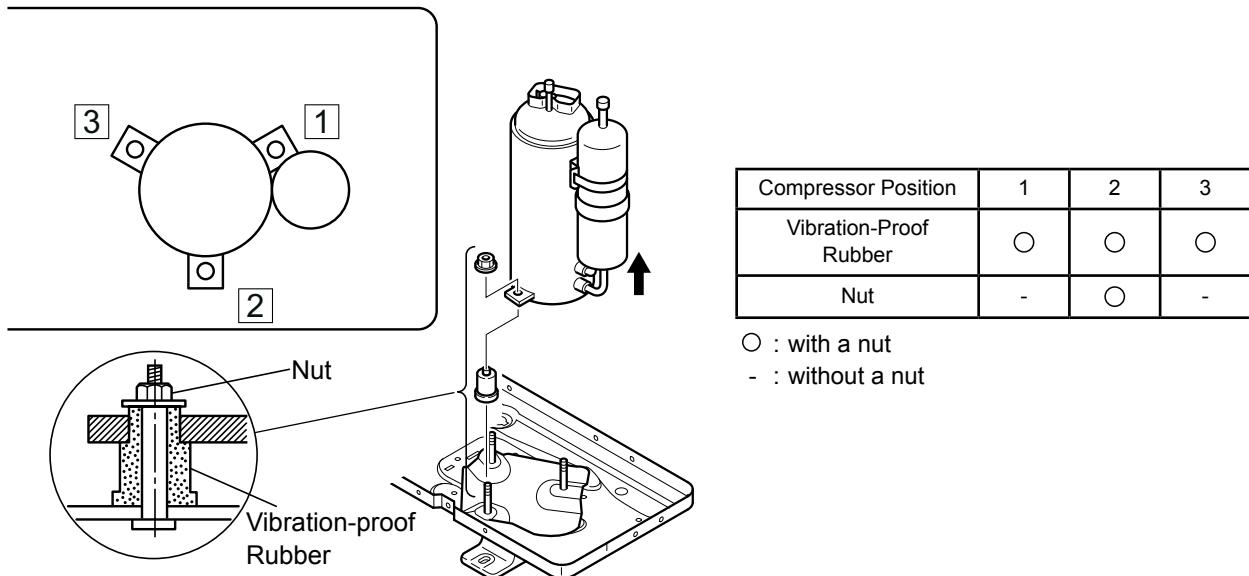

- 9 When brazing the replaced compressor braze quickly cooling the pipes on the compressor side with wet cloth to avoid the filler metal entering into the compressor.

i NOTE

PAY CLOSE ATTENTION not to let the filler metal enter into the compressor which may result in compressor damage.

10 Perform in the reverse procedure of removing after replacing the compressor.

- a. Check if the Faston terminal has any abnormality. (Ensure the pull out force greater than 20 Nm) If the Faston terminal is identified faulty replace with a new one.
- b. Ensure the fixture of the lead wires.
- c. Attach the crankcase heater to the compressor without torsion and gap as shown in the figure below.

Detail of Spring for Crankcase Heater

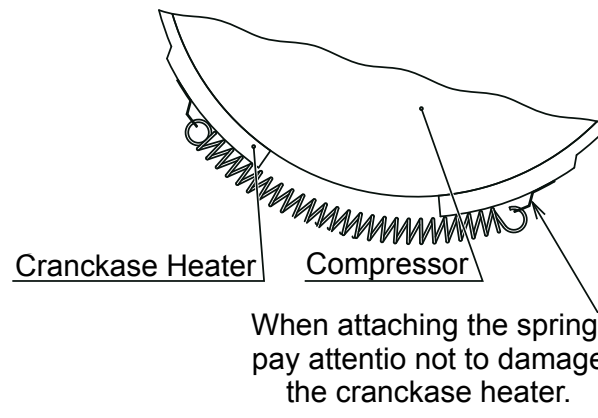

NOTE

- *To prevent contamination of the refrigerant by water or foreign materials, do not expose the refrigerant parts open to atmosphere for long periods. If necessary, seal pipe ends using caps or tape.*
- *Remove the cap for compressor right before replacing the compressor. When replacing the compressor, seal the tape at the suction and the discharge pipes to prevent foreign materials. Remove it when brazing pipes.*
- *Securely check terminal numbers and mark bands before disconnecting lead wires. When reassembling the lead wires, connect them to match surely the terminal numbers and the mark bands. If the lead wires are connected incorrectly to the terminal, the compressor will be damaged due to reverse rotation.*

10.3.1.8 Removing the High pressure switch and Pressure switch for control

- 1 Remove the service cover following [Removing service cover](#).
- 2 Collect the refrigerant from the check joint according to [Removing the compressor](#), in this chapter.

High pressure switch and pressure switch for control

- 1 Remove the soundproof cover on the compressor.
- 2 Disconnect the Faston Terminals of High Pressure Switch and Pressure sensor for PD control.
- 3 Remove the high pressure switch and the pressure switch for control from the brazed part of discharge piping.



NOTE

The procedure (2) is not required when removing the pressure sensor for PD control. However, check to ensure that the connector (CN100) on O.U. PCB1 is disconnected.

Low pressure switch

- 1 Open the P plate turning counter clockwise approximately 90° following [Opening electrical box \(P plate\)](#).
 - Check that the LED201 (red) on Inverter is OFF when the P plate is opened.



DANGER

DO NOT touch electrical components while the LED201 (Red) is ON to avoid electrical shock. Wait until the LED turns off.

- 2 Disconnect the Faston Terminals of Low Pressure Switch.
- 3 Remove the low pressure switch from the brazed part of suction piping.

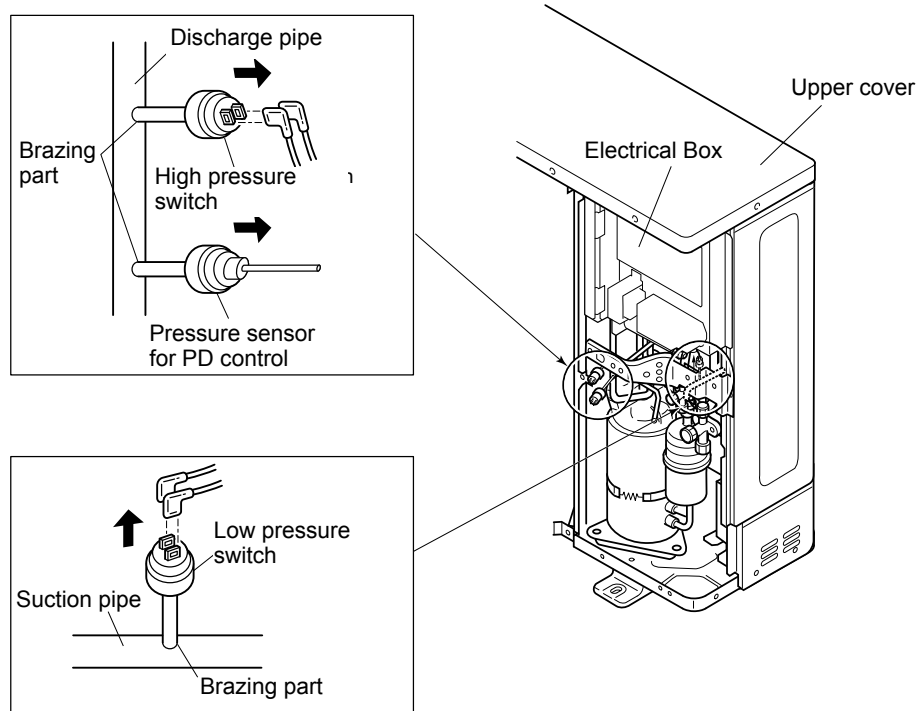

10.3.1.9 Opening electrical box (P plate)

- 1 Remove the service cover following [Removing service cover](#) in this chapter.
- 2 Unplug all the connectors of the electrical box.
- 3 Remove 5 screws which fix the electrical box and open the P plate turning counter clockwise approximately 90°.
 - Check that the LED201 (red) on the inverter PCB (PCB2) is OFF.

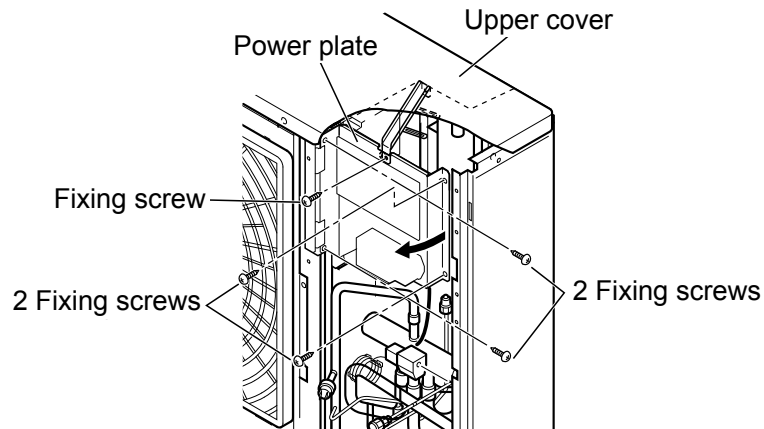

DANGER

- **DO NOT touch electrical components while the LED201 (Red) is ON to avoid electrical shock. Wait until the LED turns off.**

10.3.1.10 Removing Reversing valve coil

- 1 Remove the service cover, the bottom service cover, the rear cover and the upper cover following [Removing service cover](#), [Removing bottom service cover and rear cover](#) and [Removing upper cover](#).
- 2 Open the P plate turning counter clockwise approximately 90° following [Opening electrical box \(P plate\)](#).
 - Check that the LED201 (red) on Inverter is OFF when the P plate is opened.



DANGER

DO NOT touch electrical components while the LED201 (Red) and LED1 (Red) are ON to avoid electrical shock. Wait until the LED turn off.

- 3 Disconnect the PCN100 connector on the control PCB of the electrical box.
- 4 Remove 1 fixing screw to remove the reversing valve coil.

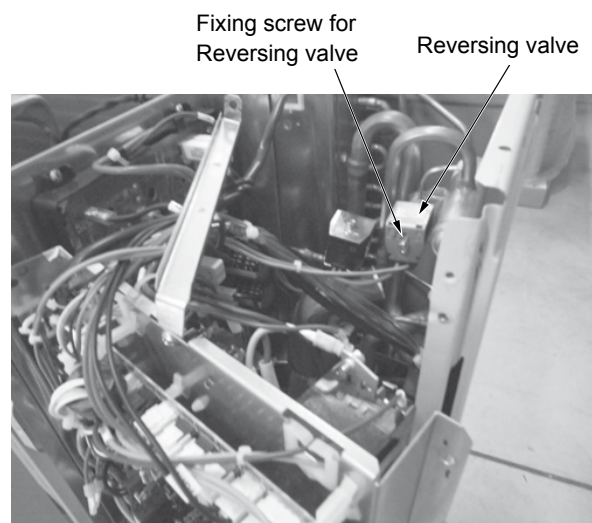

- 5 When reassembling, perform the procedure in the reverse way of removing.



NOTE

Fix the wires by plastic bands to the original position.

10.3.1.11 Removing electronic expansion valve coil

- 1 Remove the service cover following [Removing service cover](#) in this chapter.
- 2 Open the P plate turning counter clockwise approximately 90° following [Opening electrical box \(P plate\)](#).
 - Check that the LED201 (red) on Inverter is OFF when the P plate is opened.



DANGER

DO NOT touch electrical components while the LED201 (Red) and LED1 (Red) are ON to avoid electrical shock. Wait until the LED turn off.

- 3 Disconnect the CN5A connector on the control PCB of the electrical box.
- 4 Hold the coil of the expansion valve and pull out upward.
It is easier to remove the expansion valve coil if it is rotated while pulling it upward.

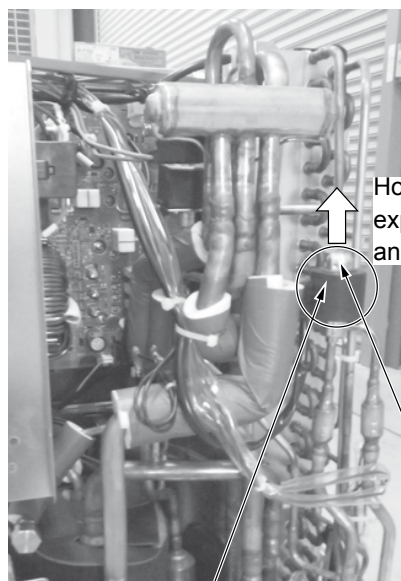

Hold the coil of the expansion valve and pull out upward

Expansion valve coil Release lock

- 5 When reassembling after replacing the expansion valve coil, perform the procedure in the reverse way of removing. The expansion valve coil is equipped with a lock mechanism. After attaching the expansion valve coil, rotate it until the sound of locking is heard.



NOTE

Fix the wires by plastic bands to the original position.

10.3.1.12 Removing solenoid valve coil (SVC)

- 1 Remove the service cover and the upper cover following [Removing service cover](#) and [Removing upper cover](#).
- 2 Unplug the connector PCN14 (SVC) on O.U. PCB1.
- 3 Remove the fixing screw, and remove the solenoid valve coil (SVC) upward.
- 4 When reassembling after replacing the solenoid valve coil, perform the procedure in the reverse way of removing.



NOTE

Fix the wires by plastic bands to the original position.



DANGER

DO NOT touch electrical components while the LED1 (Red) is ON to avoid electrical shock. Wait until the LED turns off.



10.3.1.13 Removing reversing valve

- 1 Remove the service cover, the bottom service cover, the rear cover and the upper cover following [Removing service cover](#), [Removing bottom service cover and rear cover](#) and [Removing upper cover](#).
- 2 Remove the reversing valve coil according to [Removing Reversing Valve Coil](#).
- 3 Remove the electrical box according to [Removing Electrical Box](#).
- 4 Recover the refrigerant from check joints according to [Removing Compressor](#).
- 5 Remove the valve stay.
- 6 Remove the reversing valve assemblies from the fixed positions (4 brazing parts).
 - a. Remove the reversing valve and the stop valve with cooling the valve bodies by wet cloth.
 - b. Perform the brazing work with attention not to burn the electrical wirings and the piping insulations.
- 7 Remove reversing valve from the assemblies. (4 brazing parts) At this time, perform the brazing work with cooling the reversing valve body by wet cloth.
- 8 When reassembling after replacing the reversing valves, perform in the reverse procedure of removing.
 - a. Run the lead wires to be located to the original position, and fix them by the plastic band.
 - b. Attach the crankcase heater according to [Removing Compressor](#).

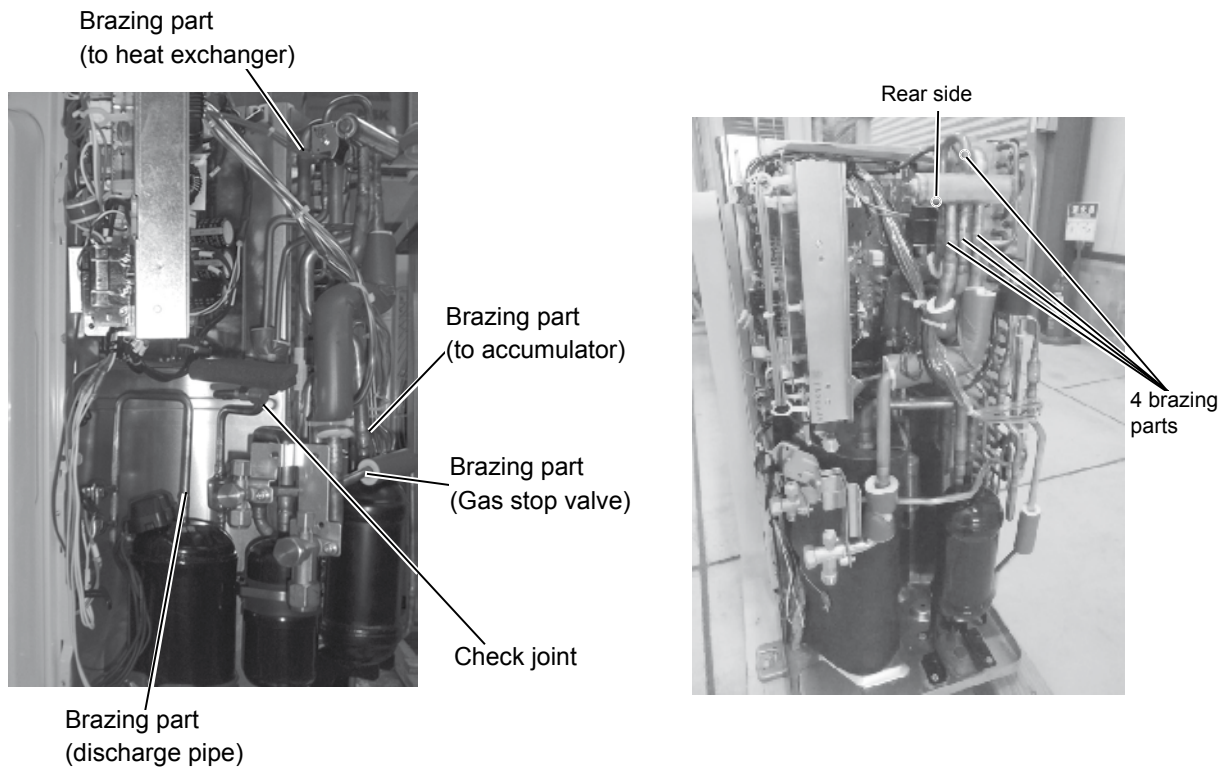

10.3.1.14 Removing Electronic expansion Valve and Solenoid Valve

- 1 Remove the service cover, the bottom service cover and the rear cover following [Removing service cover](#) and [Removing bottom service cover and rear cover](#).
- 2 Recover the refrigerant from check joints according to [Removing Compressor](#).
- 3 Remove the coils according to [Removing Electronic Expansion Valve Coil](#) and [Removing Solenoid Valve Coil](#).

- 4 Remove the brazed parts as shown in the figures.
 - Electronic Expansion Valve (EVO) Brazed Parts: 2
 - Solenoid Valve (SVC) Brazed Parts: 2
 - a. Remove the electronic expansion valve and the solenoid valve with cooling the valve bodies by wet cloth.
 - b. Perform the brazing work with attention not to burn the electrical wirings and the piping insulations.

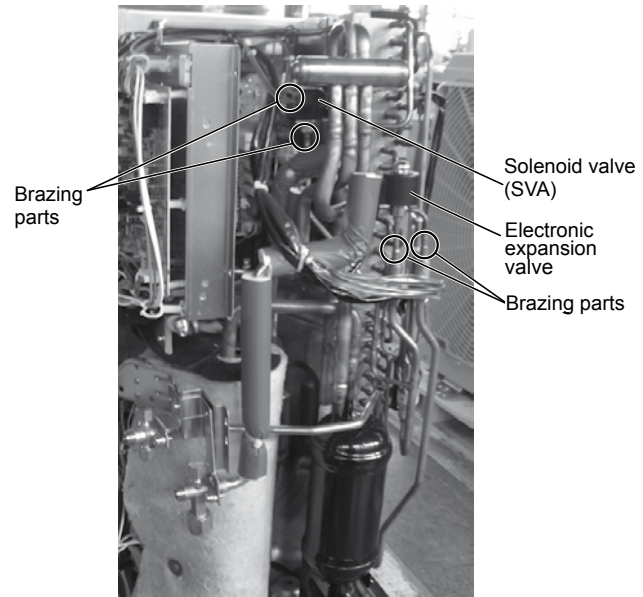

- 5 When reassembling after replacing the valves, perform in the reverse procedure of removing.



NOTE

Run the lead wires to be located to the original position, and fix them by the plastic band

10.3.1.15 Removing electrical components

◆ Removing control PCB (PCB1)

- 1 Remove the service cover following [Removing service cover](#).
- 2 Remove all the wiring connected to the control PCB.



DANGER

DO NOT touch electrical components while the LED1 (Red) is ON to avoid electrical shock. Wait until the LED turns off.

- 3 Remove the 6 holders. Clamp the middle part of the holders with long-nose pliers and remove it toward front side.



DANGER

DO NOT touch the electrical components on the PCB. Pay attention not to bend or apply much force onto PCB in order to avoid PCB failure.

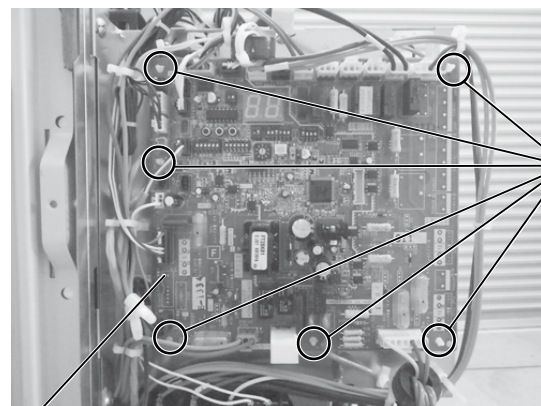

Printed Circuit Board (PCB1)

◆ Removing Inverter module

- 1 Remove the service cover following *Removing service cover* in this chapter.
- 2 Open the P plate turning counter clockwise approximately 90° following *Opening electrical box (P plate)*.
 - Check that the LED201 (red) on Inverter is OFF when the P plate is opened.



DANGER

DO NOT touch electrical components while the LED201 (Red) is ON to avoid electrical shock. Wait until the LED turns off.

- 3 Remove all the wiring connected on the Inverter.
- 4 Remove 4 screws which fix the Inverter.
Hold the wires placed at the left side.
- 5 Pull the Inverter toward right side from the front of the product. (Remove along with the plastic case and the radiation fin).

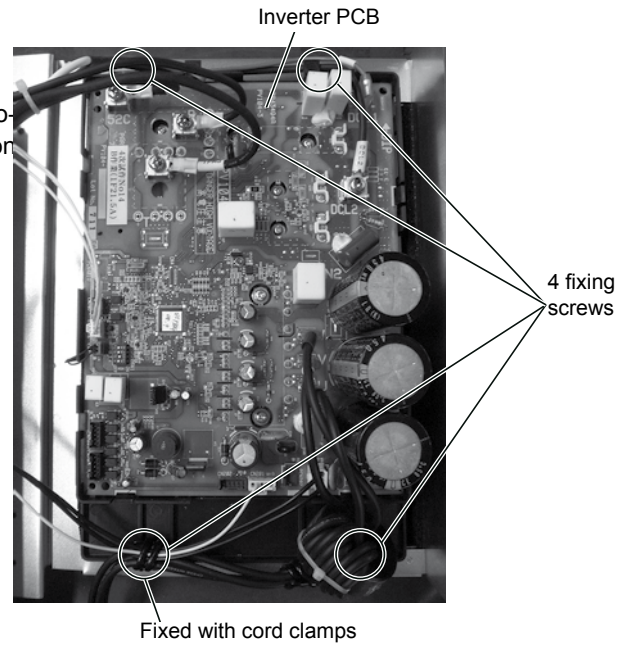

10.3.1.16 Removing other electrical components

- 1 Remove the service cover following [Removing service cover](#) in this chapter.
- 2 Open the P plate turning counter clockwise approximately 90° following [Opening electrical box \(P plate\)](#).
 - Check that the LED201 (red) on Inverter is OFF when the P plate is opened.



DANGER

DO NOT touch electrical components while the LED201 (Red) is ON to avoid electrical shock. Wait until the LED turns off.

CMC

- 1 Remove all the wiring connected to CMC.
- 2 Remove 2 screws fixing the CMC.

Reactor

- 1 Remove 4 screws fixing the reactor.

Noise filter

- 1 Remove all the wiring connected to the noise filter.
- 2 Hold the upper part of the 6 holders with the long nose pliers and remove the noise filter.

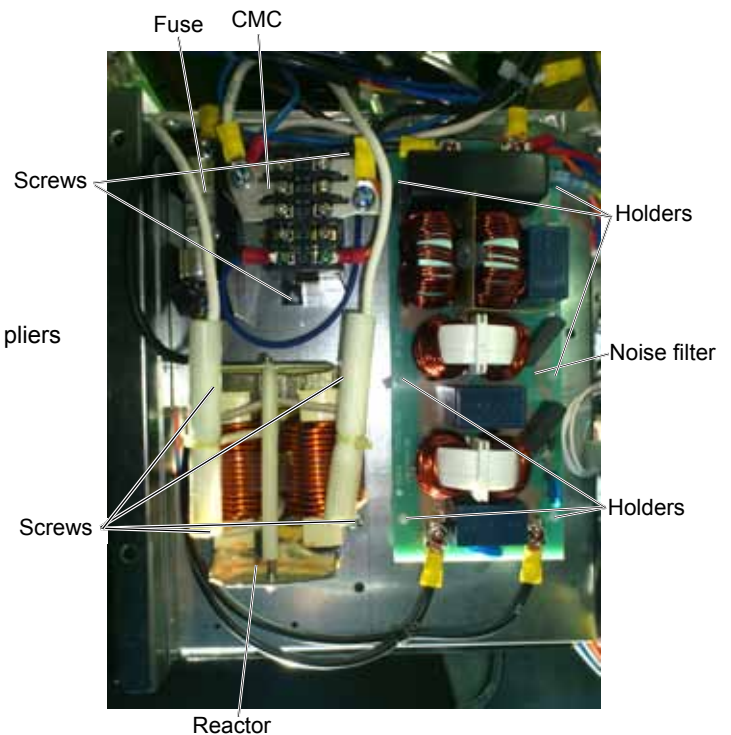
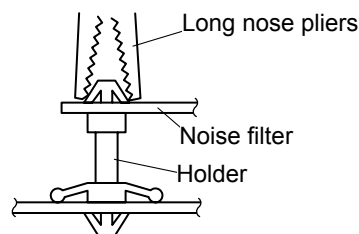

NOTE

- **To connect wiring at reassembling, ensure that the terminal numbers and wiring mark band codes are matched. If connections are wrong, there is the possibility of wrong operation and to cause damage to electrical parts.**
- **When attaching the PCB, or when attaching the parts attached to the PCB, pay attention not to clamp any wiring between plates or electrical components.**

10.3.2 Outdoor units RAS-(4-6)H(V)NPE

10.3.2.1 Removing service cover



NOTE

- Follow the procedure below to remove main parts and components. For mounting follow the reverse procedure of removal.
 - Do not expose the refrigerant cycle to the atmosphere for a long period to avoid moisture or dust entering into the cycle. Be sure to replace parts immediately after removing. Seal the refrigerant cycle when left unattached for a long period.
- 1 Remove the 4 fixing screws, slide the service cover downward and remove it.
 - Pay attention not to fall off the service cover.

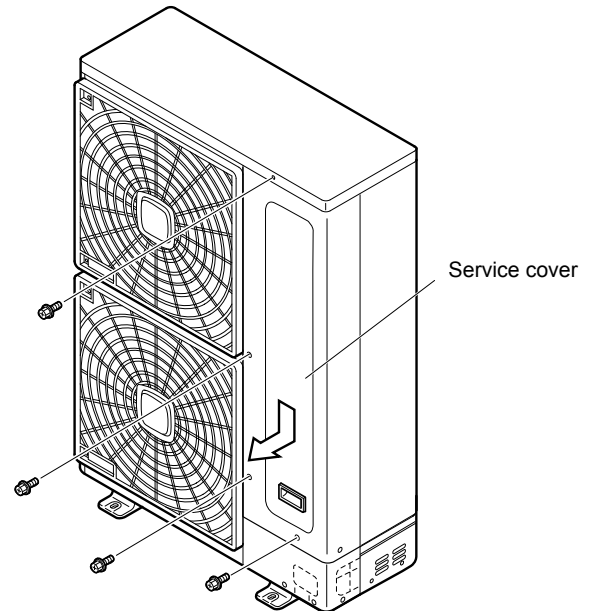

10.3.2.2 Removing air outlet grille

- 1 Remove the 8 fixing screws of the shroud.

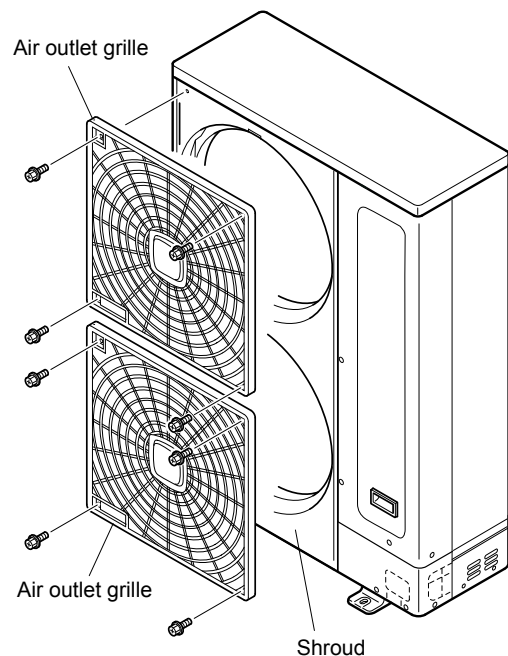

10.3.2.3 Removing upper cover

- 1 Remove 11 screws fixing the upper cover and remove the upper cover upward.

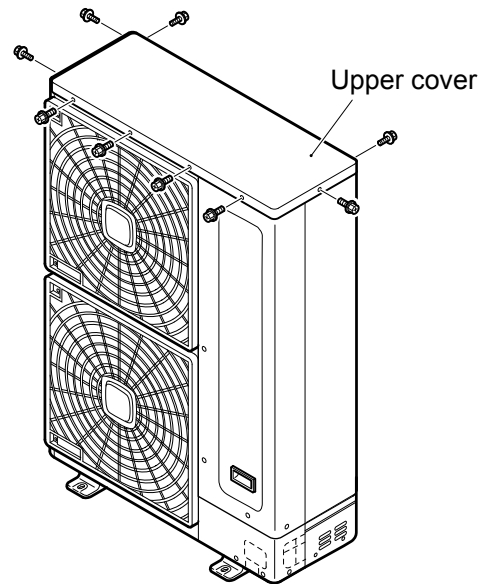
**10.3.2.4 Removing the bottom service cover and rear cover**

- 1 Remove 5 screws fixing the lower part of service cover and remove the lower part of service cover by pulling towards front side.
- 2 Remove the upper cover according to the item [Removing upper cover](#).
- 3 Remove 10 screws fixing panel and remove the rear panel by pulling in the arrow direction.

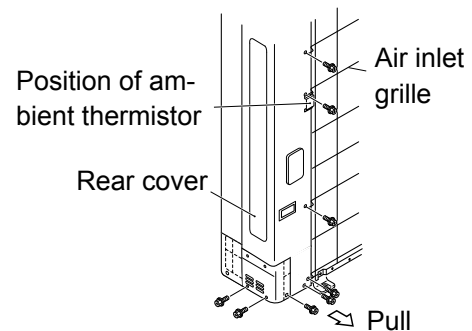
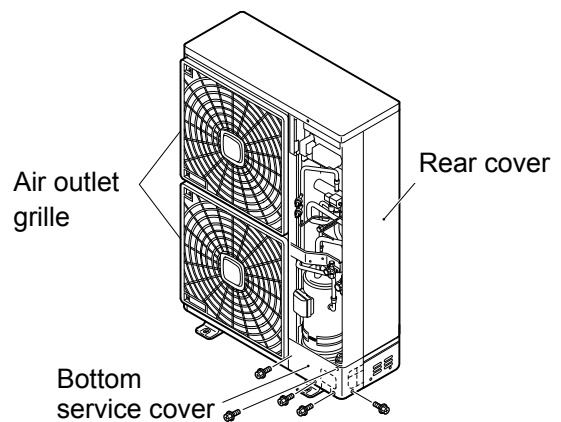

DO NOT touch electrical components while the LED1 (Red) is ON to avoid electrical shock. Wait until the LED turns off.

10.3.2.5 Removing outdoor fan motor

- 1 Remove the service cover following [Removing service cover](#).
- 2 Remove the outlet grille following [Remove outlet grille](#).
- 3 Remove the upper cover following [Removing upper cover](#).
- 4 To remove the propeller fan remove the cap nut and washer which fix the propeller fan onto the motor shaft. (Use a puller when the propeller fan and motor shaft are fixed too tightly).

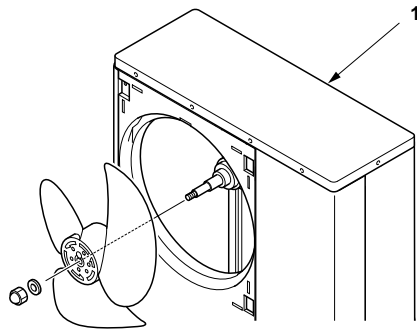

1. Upper cover.

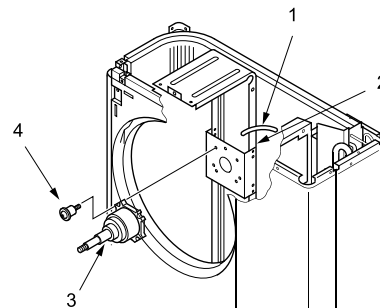

1. Fan motor lead wire.
2. Motor clamp.
3. Motor.
4. Screw with spacer.

- 5 Remove the fan motor connector from PCB in the electrical box.
Cut the plastic tie with nippers which fixes the fan motor lead wire onto the motor clamp.
Remove 4 screws which fix the motor.

Model		RAS-(4-6)H(V)NPE
Fan Motor Comp. N°	DC Fan Motor	Inverter PCB CN202 (Red)
	AC Fan Motor	inverter PCB CN201 (White)
Screws for motor fixing.	DC Fan Motor	4 x M4 screw (with spacer)
	AC Fan Motor	4x M4 screws

<ol style="list-style-type: none"> 1. Motor clamp. 2. Fan motor lead wire. 3. Plastic tie. 4. DC Fan Motor. 5. AC Fan Motor. 	
---	--



NOTE

- 1 **To mount the motor be sure to place the lead wire outlet downward.**
(Adjust the propeller fan and shroud not to contact with each other).
- 2 **Fix the motor lead wire onto the motor clamp using a plastic tie as shown in the table on the previous page to avoid obstructing the propeller fan.**
- 3 **Mounting propeller fan:**
Insert the skidding protection part of the fan boss matching with the motor shaft notch; tighten the nut after the shaft screw fully comes out. (Tightening Torque 20 Nm)
- 4 **Connect the motor lead wire to PCB1 of the electrical box.**
(Be sure to match colors of the PCB connectors and motor lead wire connectors).
- 5 **Be sure to attach the outlet grill onto the shroud after replacing the fan motor.**

10.3.2.6 Removing electrical box

- 1 Remove the service cover following [Removing service cover](#).
- 2 Remove the upper cover following [Removing upper cover](#).
- 3 Remove 4 screws which fix the electrical box.
- 4 Pull up and remove the electrical box.

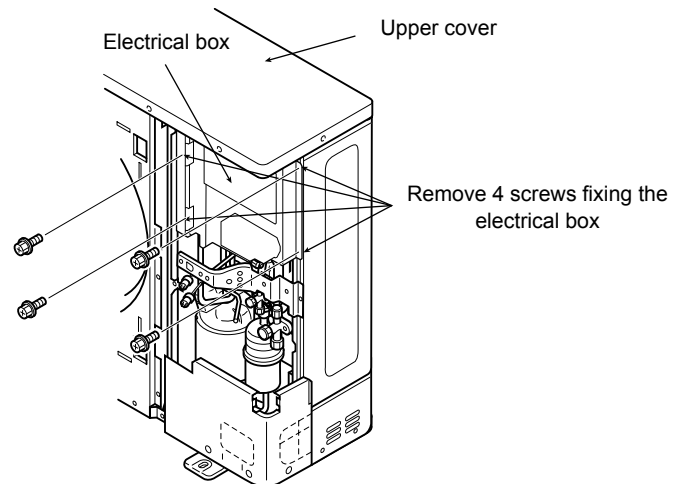

NOTE

The following wiring must be removed to dismount the electrical box.

1. Remove the reversing valve coil from the reversing valve. : [Removing reversing valve coil](#).
2. Remove the expansion valve coil from the expansion valve. : [Removing electronic expansion valve coil](#).
3. Remove the solenoid valve coil from the solenoid valve. : [Removing solenoid valve coil](#).
4. Remove the Faston terminals of high/low pressure switch and the pressure switch for control from the switch body : [Removing the high pressure switch, low pressure switch and pressure switch for control](#).
5. Remove all connectors on the control PCB.
6. Remove the compressor wires in the terminal box of the compressor.
7. To remount the electrical box attach the electrical box fitting with the partition plate.
(Insert the radiation fin into the U-notch on the partition plate and place the fin on the fan box side. Then attach the electrical box hooking onto the partition plate).



Original position

Front side

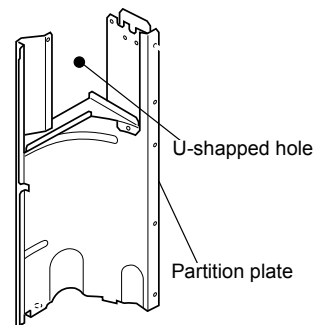

U-shaped hole

Partition plate

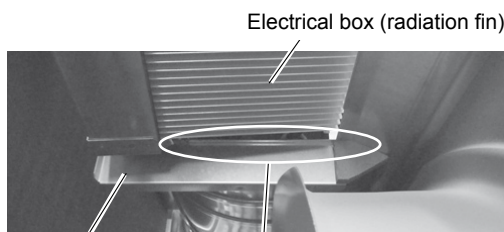

Electrical box (radiation fin)

Front side

Partition plate

Place the electrical box (radiation fin) in front of the partition plate.
(Refer to the original position)

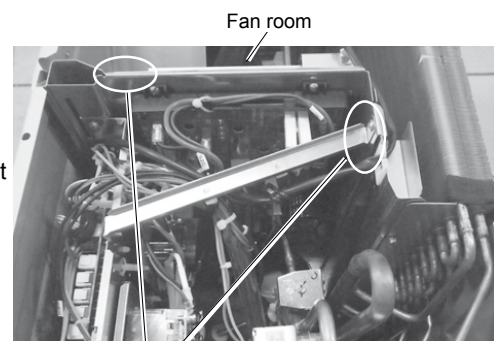

Fan room

Front side

Place the electrical box to hook the parts onto the partition plate.

10.3.2.7 Removing the compressor

- 1 Remove the service cover, bottom service cover and rear cover following *Removing service cover* and *Removing bottom service cover and rear cover*. When the outdoor unit is installed close to a wall remove the refrigerant piping and move the unit from the wall.
- 2 Collect the refrigerant from the check joint.
- 3 Remove the valve stay.



NOTE

Check Perform the recovery work at the check joint of piping. If not, the refrigerant remains inside.

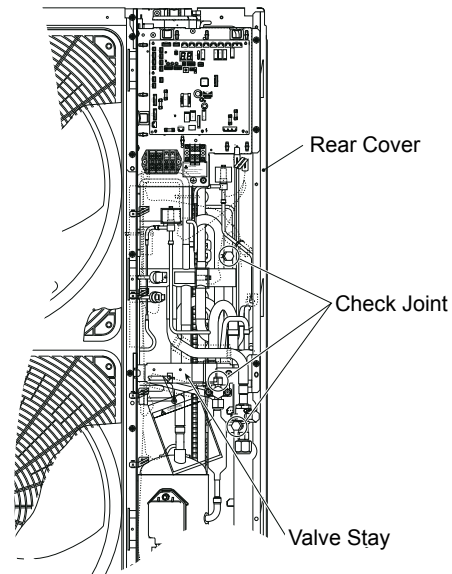

- 4 Open the soundproof cover wrapped around the compressor and remove the terminal box cover of the compressor body. Disconnect the compressor wires in the terminal box and disconnect the thermistor on top of the compressor. Remove the soundproof cover.



NOTE

Check the terminal codes and mark bands when disconnecting the wires. Connecting wires in wrong order at reassembling may result in compressor damage.

- 5 Remove the rubber cap and the thermistor attached on top of the compressor.
- 6 Remove the crankcase heater.

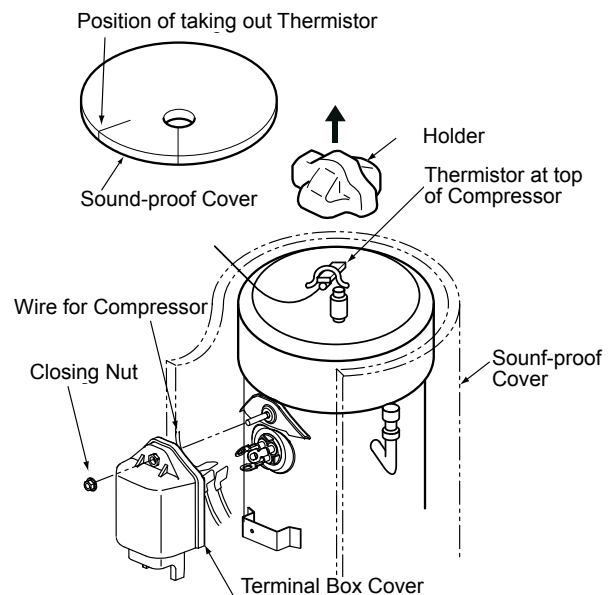

NOTE

- **Compressor piping must be connected by brazing. MAKE SURE that any flammable material is not around before heating with burner for the oil inside the piping may flame up.**
- **Do not expose the refrigerant cycle to the atmosphere for a long period to avoid moisture or dust into the cycle. Be sure to replace the compressor immediately after removing. Seal the suction and discharge pipes when the refrigerant cycle is left unattached for a long period.**
- **Remove the cap of new compressor right before the replacement. Before mounting the compressor seal the suction and discharge pipes with a tape to protect the compressor from dust. Remove the tape when blazing the pipe.**
- **For piping at reassembling ensure that the compressor terminal numbers and wiring mark band codes are matched. Incorrect wiring numbers may result in inverse rotation and damage of the compressor.**

- 7 Remove the suction pipe and discharge pipe from the compressor.

i NOTE

Be sure to separate the blazing burner flame sufficiently from the wires and electrical components around the brazed part in order to avoid burning.

- 8 Remove 2 nuts which fix the compressor and remove it by lifting it up with inclining forward.

i NOTE

To remove the compressor the liquid stop valve pipe should be moved (bent) to the right side hand. PAY CLOSE ATTENTION not to crush to break the pipe.

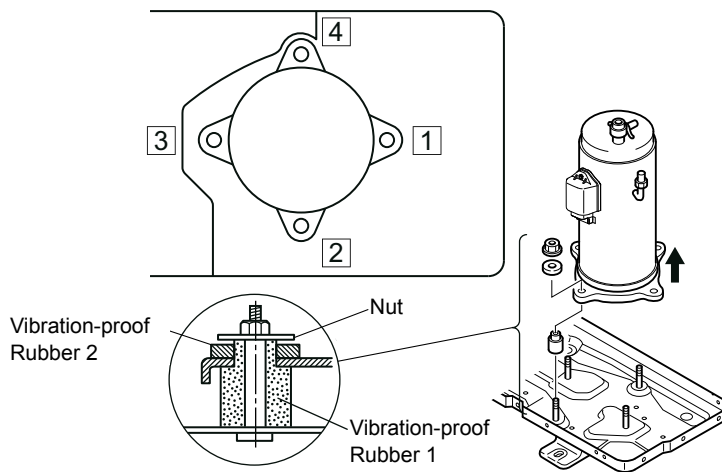

Fixation of the compressor to the bottom plate				
Compressor position	1	2	3	4
Vibration-proof rubber 1	x	x	x	x
Vibration-proof rubber 2	x	x	—	—
Nut	x	x	—	—

- 9 When brazing the replaced compressor quickly perform the brazing while the compressor side piping is cooled with wet cloth in order to avoid the brazing material from entering the compressor.

i NOTE

PAY CLOSE ATTENTION not to let the filler metal enter into the compressor which may result in compressor damage.

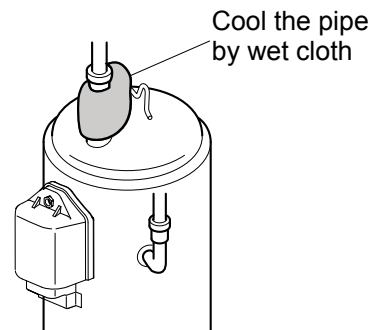

10 Perform in the reverse procedure of removing after replacing the compressor.

- a. Check if the Faston terminal has any abnormality. (Ensure the pull out force greater than 20 Nm). If the Faston terminal is identified faulty replace with a new one.
- b. Ensure the fixture of the lead wires.
- c. Surely fix the terminal box by tightening the closing nut (Tightening Torque: 3.0 Nm).
- d. Attach the top of sound-proof cover to cover surely the compressor.
- e. Wrap the sound-proof cover to cover the terminal box and the discharge pipe.
- f. Attach the crankcase heater without torsion and gap to the compressor as following figure.

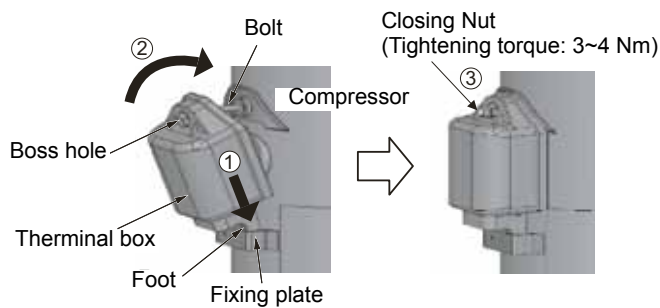
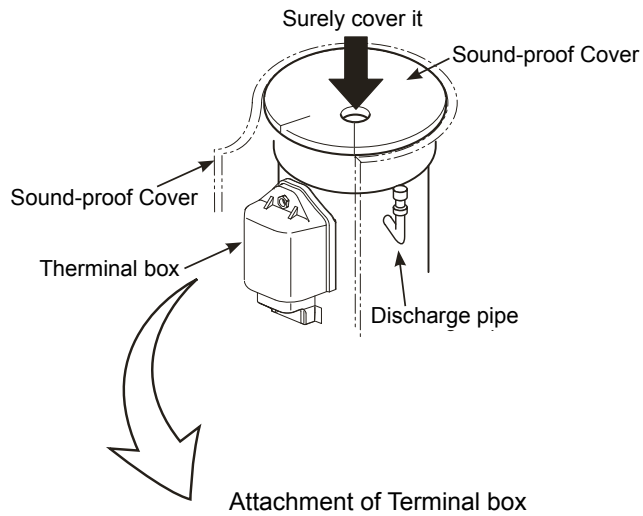

Detail of Spring for Cranckase Heater

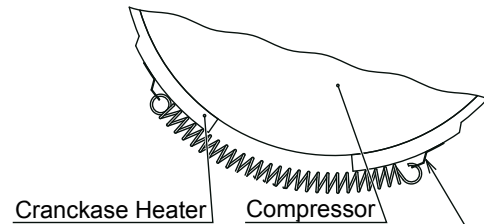

When attaching the spring, pay attentio not to damage the cranckase heater.

10.3.2.8 Removing the High pressure switch and Pressure switch for control

- 1 Remove the service cover and the bottom service cover following *Removing service cover*, and *Removing bottom service cover and rear cover*.
- 2 Collect the refrigerant from the check joint according to *Removing the compressor*, in this chapter.

High pressure switch and pressure switch for control

- 1 Disconnect the Faston Terminals of High Pressure Switch and Pressure sensor for PD control.
- 2 Remove the high pressure switch and the pressure switch for control from the brazed part of discharge piping.



NOTE

The procedure (1) is not required when removing the pressure sensor for PD control. However, check to ensure that the connector (CN100) on O.U. PCB1 is disconnected.

Low pressure switch

- 1 Disconnect the Faston Terminals of Low Pressure Switch.
- 2 Remove the low pressure switch from the brazed part of suction piping.

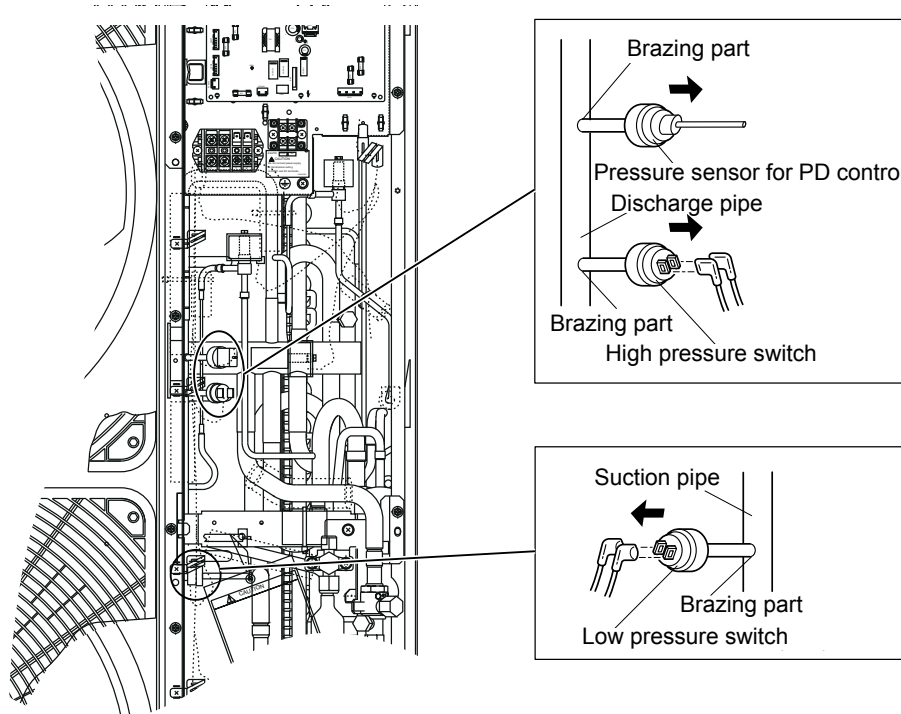

10.3.2.9 Opening electrical box (P plate)

- 1 Remove the service cover following [Removing service cover](#) in this chapter.
- 2 Unplug all the connectors of the electrical box.
- 3 Remove 5 screws which fix the electrical box and open the P plate turning counter clockwise approximately 90°.
 - Check that the LED201 (red) on the inverter PCB (PCB2) is OFF.

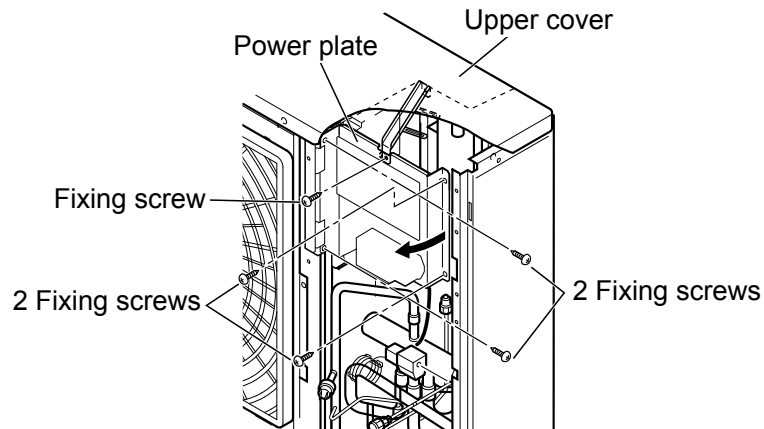

DANGER

- **DO NOT touch electrical components while the LED201 (Red) is ON to avoid electrical shock. Wait until the LED turns off.**

10.3.2.10 Removing Reversing valve coil

- 1 Remove the service cover, the bottom service cover, the rear cover and the upper cover following [Removing service cover](#), [Removing bottom service cover and rear cover](#) and [Removing upper cover](#).



DANGER

DO NOT touch electrical components while the LED1 (Red) is ON to avoid electrical shock. Wait until the LED turns off.

- 2 Disconnect the PCN100 connector on the control PCB of the electrical box.
- 3 Remove 1 fixing screw to remove the reversing valve coil.

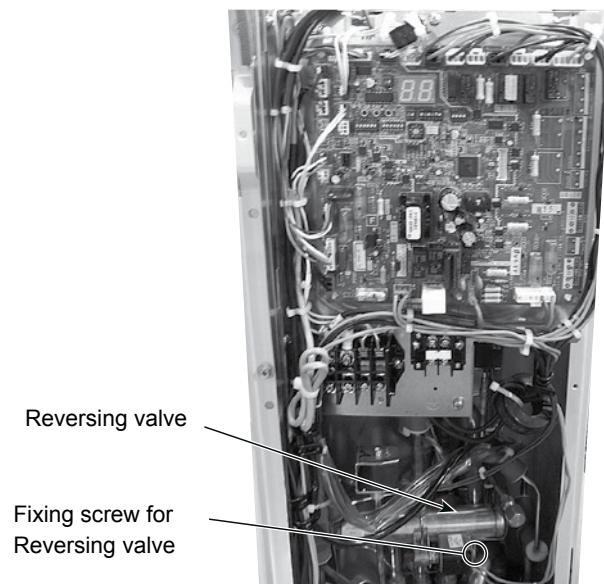

- 4 When reassembling, perform the procedure in the reverse way of removing.



NOTE

Fix the wires by plastic bands to the original position.

10.3.2.11 Removing electronic expansion valve coil

- 1 Remove the service cover, the bottom service cover and the rear cover following [Removing service cover](#) and [Removing bottom service cover and rear cover](#).



DANGER

DO NOT touch electrical components while the LED1 (Red) is ON to avoid electrical shock. Wait until the LED turns off.

- 2 Disconnect the CN5A connector on the control PCB of the electrical box.
- 3 Hold the coil of the expansion valve and pull out upward.
It is easier to remove the expansion valve coil if it is rotated while pulling it upward.

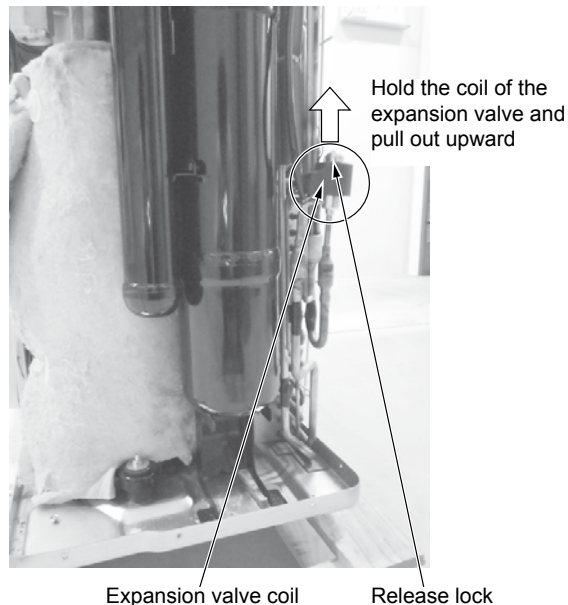

- 4 When reassembling after replacing the expansion valve coil, perform the procedure in the reverse way of removing. The expansion valve coil is equipped with a lock mechanism. After attaching the expansion valve coil, rotate it until the sound of locking is heard.



NOTE

Fix the wires by plastic bands to the original position.

10.3.2.12 Removing solenoid valve coil (SVA and SVC)

- 1 Remove the service cover and the upper cover following [Removing service cover](#) and [Removing upper cover](#).
- 2 Unplug the connector PCN7 (SVA) and PCN14 (SVC) on O.U. PCB1.
- 3 Remove the fixing screw, and remove the solenoid valve coils (SVA and SVC) upward.
- 4 When reassembling after replacing the solenoid valve coil, perform the procedure in the reverse way of removing.



NOTE

Fix the wires by plastic bands to the original position.

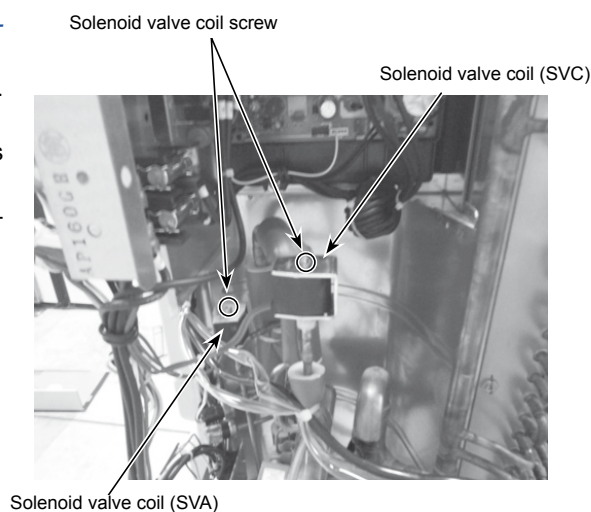

DANGER

DO NOT touch electrical components while the LED1 (Red) is ON to avoid electrical shock. Wait until the LED turns off.

10.3.2.13 Removing reversing valve

- 1 Remove the service cover, the bottom service cover, the rear cover and the upper cover following [Removing service cover](#), [Removing bottom service cover and rear cover](#) and [Removing upper cover](#).
- 2 Recover the refrigerant from check joints according to [Removing Compressor](#).
- 3 Remove the reversing valve coil according to [Removing Reversing Valve Coil](#).
- 4 Remove the reversing valve assemblies from the fixed positions (5 brazing parts).
 - a. Remove the reversing valve and the stop valve with cooling the valve bodies by wet cloth.
 - b. Perform the brazing work with attention not to burn the electrical wirings and the piping insulations.
- 5 Remove reversing valve from the assemblies. (5 brazing parts) At this time, perform the brazing work with cooling the reversing valve body by wet cloth.
- 6 When reassembling after replacing the reversing valves, perform in the reverse procedure of removing.
 - a. Run the lead wires to be located to the original position, and fix them by the plastic band.
 - b. Attach the crankcase heater according to [Removing Compressor](#).

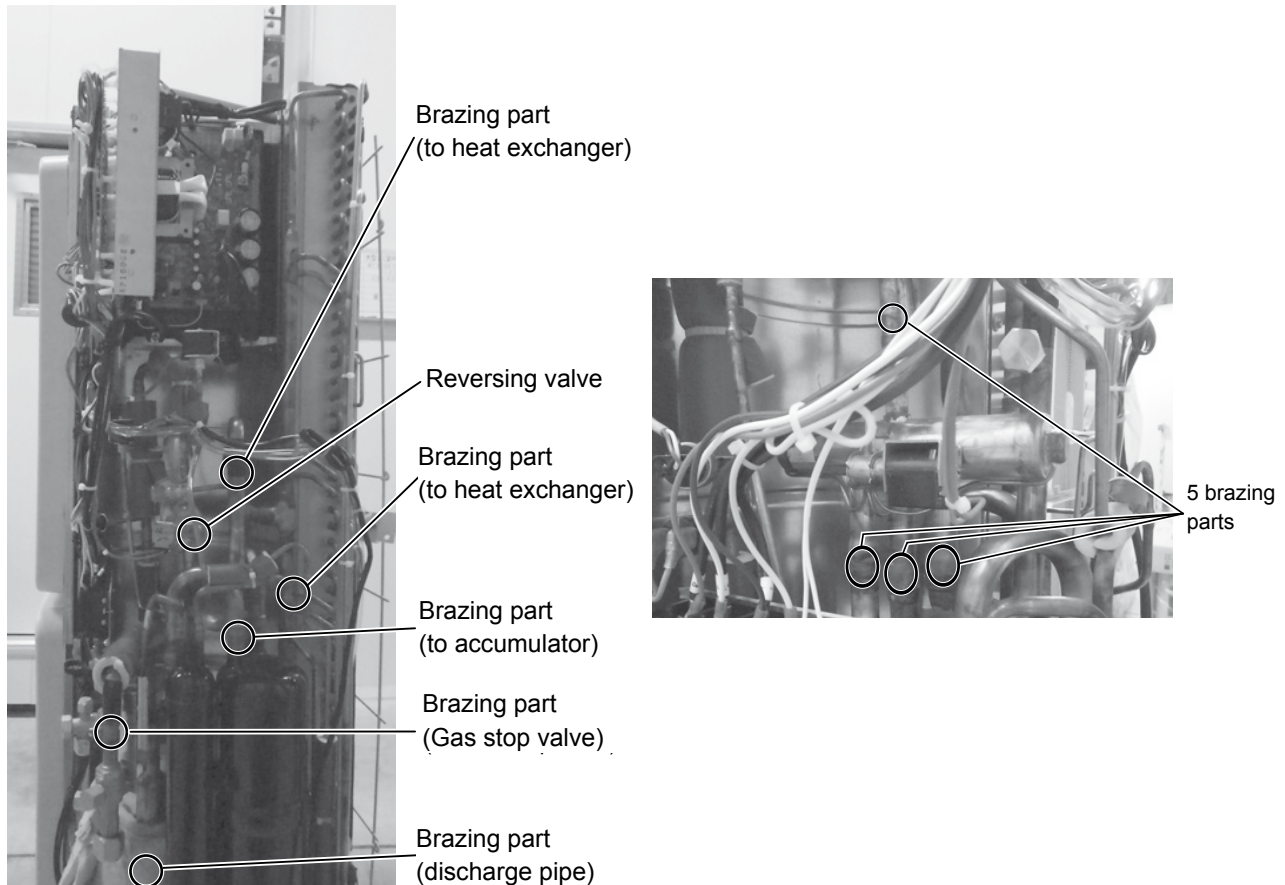

10.3.2.14 Removing Electronic expansion Valve and Solenoid Valve

- 1 Remove the service cover, the bottom service cover and the rear cover following *Removing service cover* and *Removing bottom service cover and rear cover*.
- 2 Recover the refrigerant from check joints according to *Removing Compressor*.
- 3 Remove the coils according to *Removing Electronic Expansion Valve Coil* and *Removing Solenoid Valve Coil*.
- 4 Remove the brazed parts as shown in the figures.
 - Electronic Expansion Valve (EVO) Brazed Parts: 2
 - Solenoid Valve (SVA) Brazed Parts: 2
 - Solenoid Valve (SVC) Brazed Parts: 2
 - a. Remove the electronic expansion valve and the solenoid valve with cooling the valve bodies by wet cloth.
 - b. Perform the brazing work with attention not to burn the electrical wirings and the piping insulations.

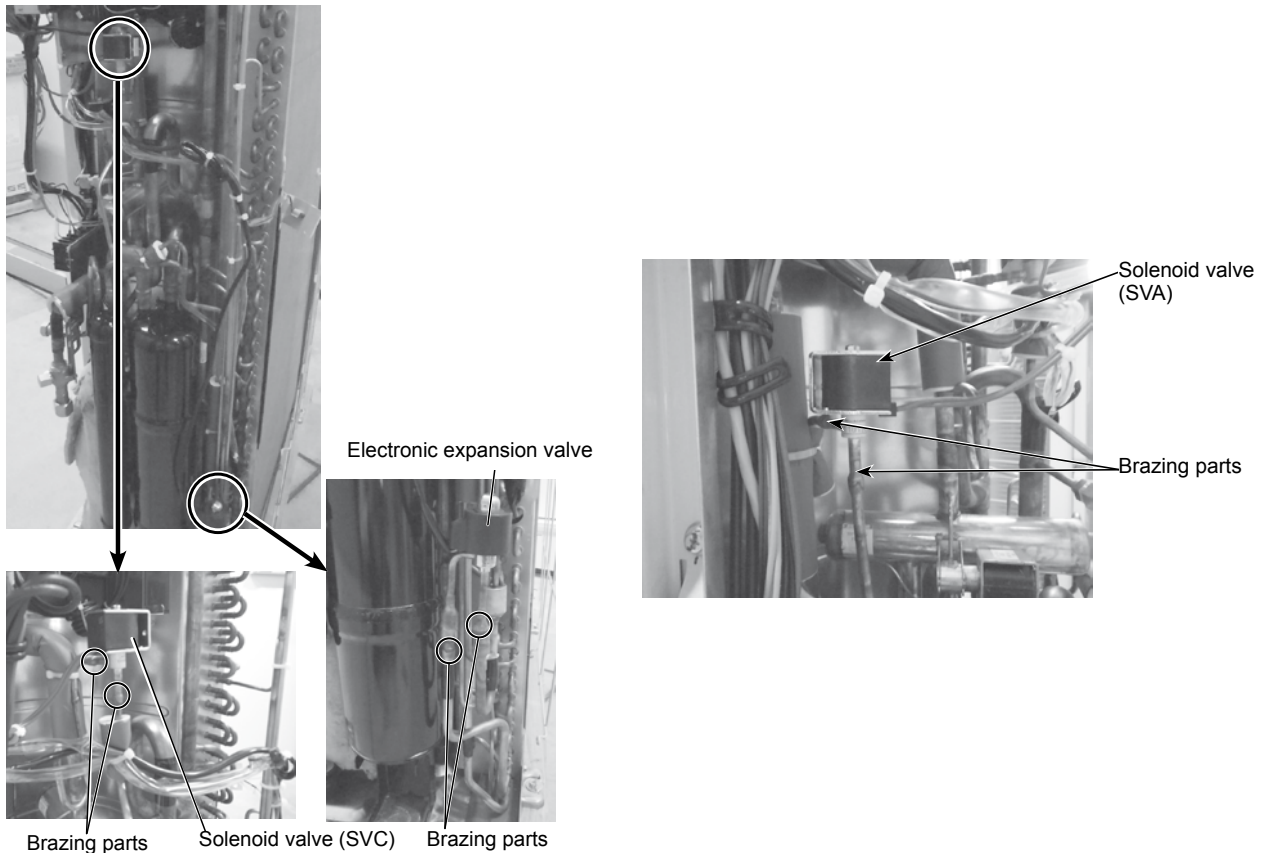

- 5 When reassembling after replacing the valves, perform in the reverse procedure of removing.

i NOTE

Run the lead wires to be located to the original position, and fix them by the plastic band

10.3.2.15 Removing electrical components

◆ Removing control PCB (PCB1)

- 1 Remove the service cover following [Removing service cover](#).
- 2 Remove all the wiring connected to the control PCB.



DANGER

DO NOT touch electrical components while the LED1 (Red) is ON to avoid electrical shock. Wait until the LED turns off.

- 3 Remove the 6 holders. Clamp the middle part of the holders with long-nose pliers and remove it toward front side.



DANGER

DO NOT touch the electrical components on the PCB. Pay attention not to bend or apply much force onto PCB in order to avoid PCB failure.

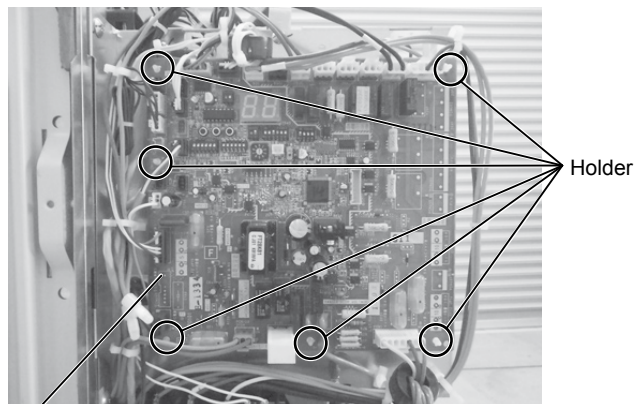

Printed Circuit Board (PCB1)

◆ Removing Inverter module

- 1 Remove the service cover following [Removing service cover](#) in this chapter.
- 2 Open the P plate turning counter clockwise approximately 90° following [Opening electrical box \(P plate\)](#).
 - Check that the LED201 (red) on Inverter is OFF when the P plate is opened.



DANGER

DO NOT touch electrical components while the LED201 (Red) is ON to avoid electrical shock. Wait until the LED turns off.

- 3 Remove all the wiring connected on the Inverter.
- 4 Remove 4 screws which fix the Inverter. Hold the wires placed at the bottom side.
- 5 Pull the Inverter toward right side from the front of the product. (Remove along with the plastic case and the radiation fin).

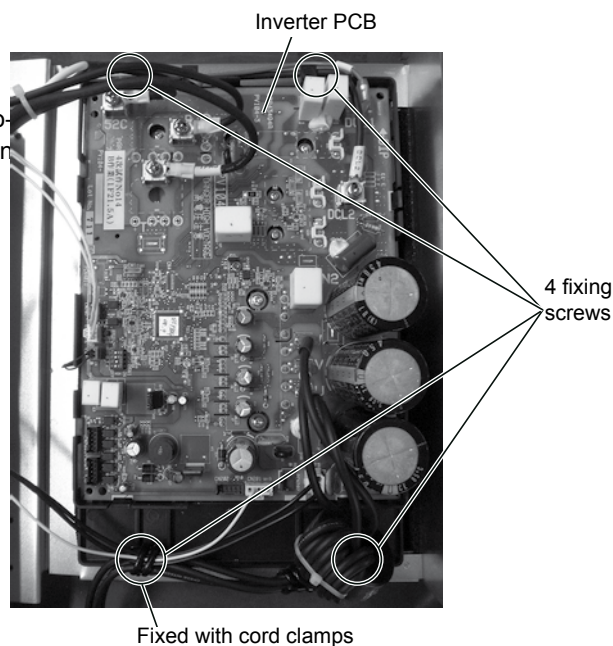

10.3.2.16 Removing other electrical components

- 1 Remove the service cover following [Removing service cover](#) in this chapter.
- 2 Open the P plate turning counter clockwise approximately 90° following [Opening electrical box \(P plate\)](#).
 - Check that the LED201 (red) on Inverter is OFF when the P plate is opened.



DANGER

DO NOT touch electrical components while the LED201 (Red) is ON to avoid electrical shock. Wait until the LED turns off.

CMC

- 1 Remove all the wiring connected to CMC.
- 2 Remove 2 screws fixing the CMC.

Reactor

- 1 Remove 4 screws fixing the reactor.

Noise filter

- 1 Remove all the wiring connected to the noise filter.
- 2 Hold the upper part of the 6 holders with the long nose pliers and remove the noise filter.

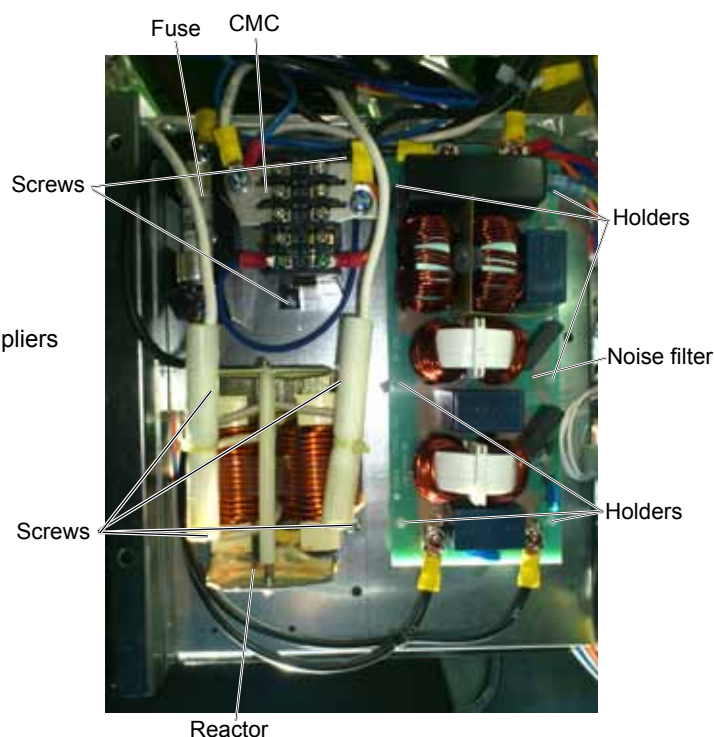
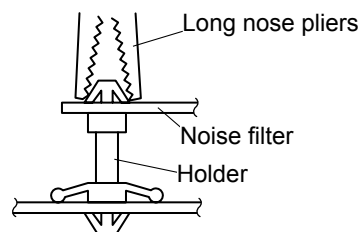

NOTE

- **To connect wiring at reassembling, ensure that the terminal numbers and wiring mark band codes are matched. If connections are wrong, there is the possibility of wrong operation and to cause damage to electrical parts.**
- **When attaching the PCB, or when attaching the parts attached to the PCB, pay attention not to clamp any wiring between plates or electrical components.**

10.3.3 Outdoor units RAS-(8-10)HNPE

10.3.3.1 Removing service cover



NOTE

- *Follow the procedure below to remove main parts and components. For mounting follow the reverse procedure of removal.*
 - *Do not expose the refrigerant cycle to the atmosphere for a long period to avoid moisture or dust entering into the cycle. Be sure to replace parts immediately after removing. Seal the refrigerant cycle when left unattached for a long period.*
- 1 Remove the 4 fixing screws, slide the service cover downward and remove it.
 - Pay attention not to fall off the service cover.

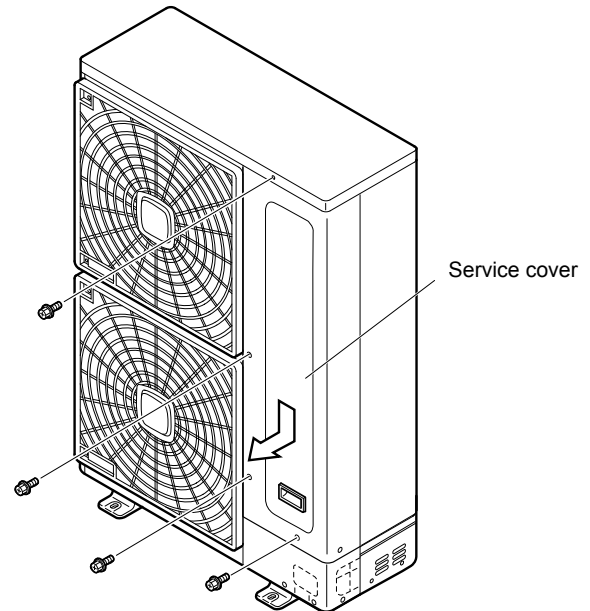

10.3.3.2 Removing air outlet grille

- 1 Remove the 8 fixing screws of the shroud.

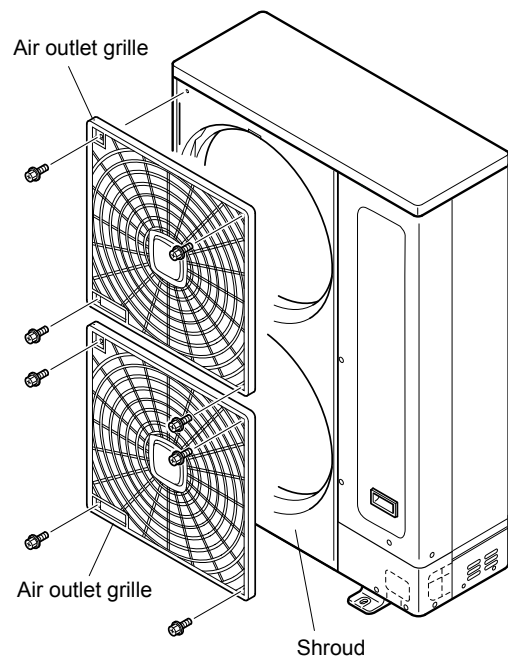

10.3.3.3 Removing upper cover

- 1 Remove 11 screws fixing the upper cover and remove the upper cover upward.

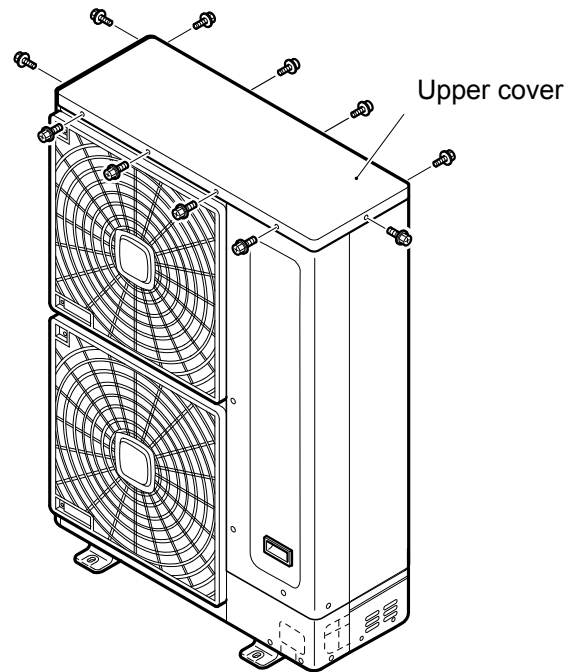
**10.3.3.4 Removing the bottom service cover and rear cover**

- 1 Remove 5 screws fixing the lower part of service cover and remove the lower part of service cover by pulling towards front side.
- 2 Remove the upper cover according to the item [Removing upper cover](#).
- 3 Remove 10 screws fixing panel and remove the rear panel by pulling in the arrow direction.

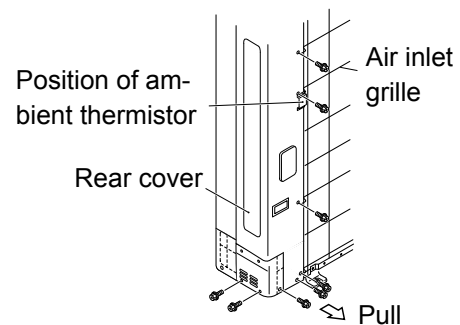
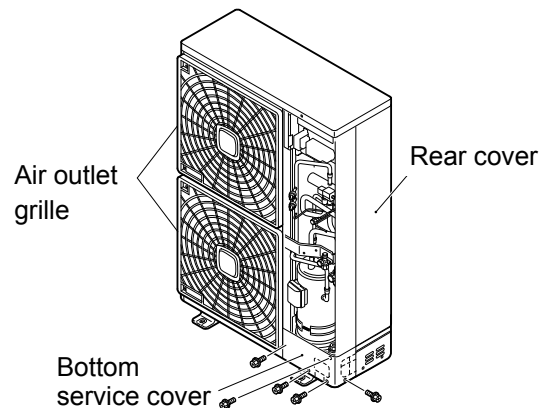

DO NOT touch electrical components while the LED1 (Red) is ON to avoid electrical shock. Wait until the LED turns off.

10.3.3.5 Removing outdoor fan motor

- 1 Remove the service cover following [Removing service cover](#).
- 2 Remove the outlet grille following [Remove outlet grille](#).
- 3 Remove the upper cover following [Removing upper cover](#).
- 4 To remove the propeller fan remove the cap nut and washer which fix the propeller fan onto the motor shaft. (Use a puller when the propeller fan and motor shaft are fixed too tightly).

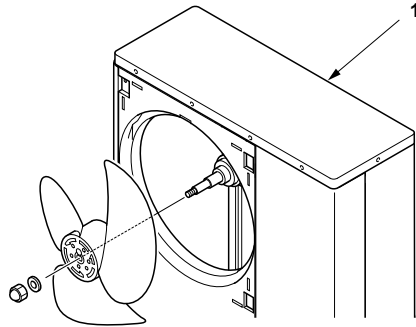

1. Upper cover.

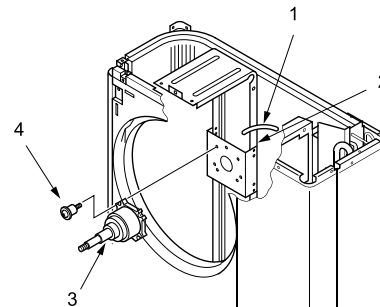

1. Fan motor lead wire.
2. Motor clamp.
3. Motor.
4. Screw with spacer.

- 5 Remove the fan motor connector from PCB in the electrical box.
Cut the plastic tie with nippers which fixes the fan motor lead wire onto the motor clamp.
Remove 4 screws which fix the motor.

Model		RAS-(8-10)HNCE
Fan Motor Comp. N°	DC Fan Motor	Inverter PCB CN406 (Red)
	AC Fan Motor	inverter PCB CN405 (White)
Screws for motor fixing.	DC Fan Motor	4 x M6 screw (with spacer)
	AC Fan Motor	4x M6 screws

<ol style="list-style-type: none"> 1. Motor clamp. 2. Fan motor lead wire. 3. Plastic tie. 4. DC Fan Motor. 5. AC Fan Motor. 	
---	--



NOTE

- 1 **To mount the motor be sure to place the lead wire outlet downward.**
(Adjust the propeller fan and shroud not to contact with each other).
- 2 **Fix the motor lead wire onto the motor clamp using a plastic tie as shown in the table on the previous page to avoid obstructing the propeller fan.**
- 3 **Mounting propeller fan:**
Insert the skidding protection part of the fan boss matching with the motor shaft notch; tighten the nut after the shaft screw fully comes out. (Tightening Torque 20 Nm)
- 4 **Connect the motor lead wire to PCB1 of the electrical box.**
(Be sure to match colors of the PCB connectors and motor lead wire connectors).
- 5 **Be sure to attach the outlet grill onto the shroud after replacing the fan motor.**

10.3.3.6 Removing electrical box

- 1 Remove the service cover following [Removing service cover](#).
- 2 Remove the upper cover following [Removing upper cover](#).
- 3 Remove 6 screws which fix the electrical box.
- 4 Pull up and remove the electrical box.

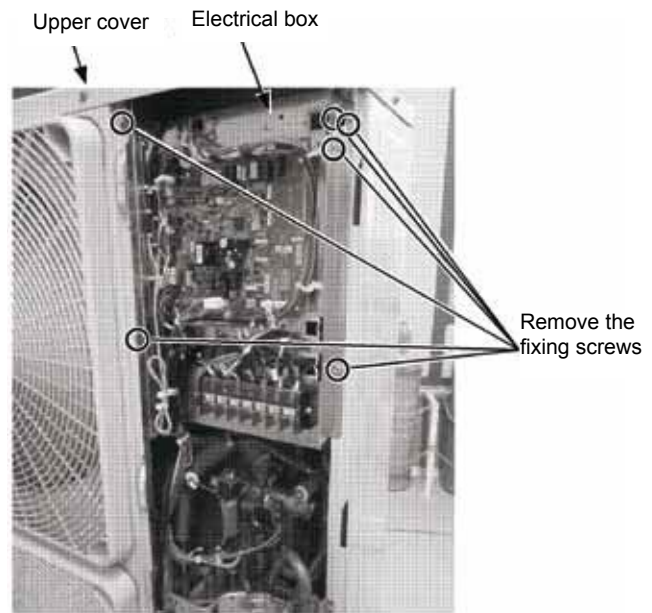

NOTE

The following wiring must be removed to dismount the electrical box.

1. Remove the reversing valve coil from the reversing valve. : [Removing reversing valve coil](#).
2. Remove the expansion valve coil from the expansion valve. : [Removing electronic expansion valve coil](#).
3. Remove the solenoid valve coil from the solenoid valve. : [Removing solenoid valve coil](#).
4. Remove the Faston terminals of high/low pressure switch and the pressure switch for control from the switch body : [Removing the high pressure switch, the low pressure switch and pressure switch for control](#).
5. Remove all connectors on the control PCB.
6. Remove the compressor wires in the terminal box of the compressor.
7. To remount the electrical box attach the electrical box fitting with the partition plate.
(Insert the radiation fin into the U-notch on the partition plate and place the fin on the fan box side. Then attach the electrical box hooking onto the partition plate).



Front side

Original position

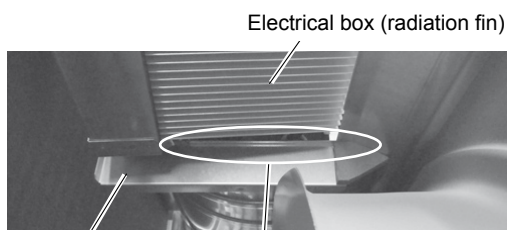

Front side

Partition plate

Place the electrical box (radiation fin) in front of the partition plate.
(Refer to the original position)

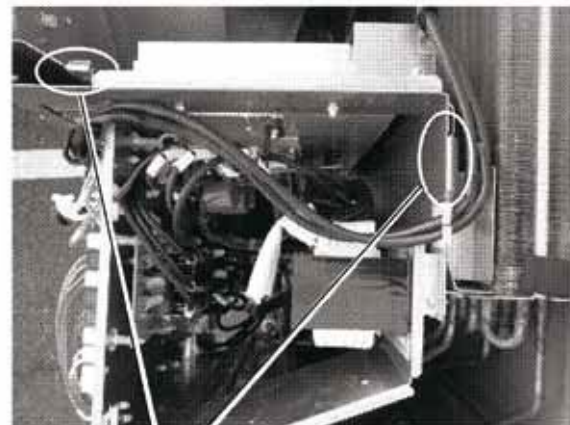

Place the electrical box to hook the parts onto the partition plate.

10.3.3.7 Removing the compressor

- 1 Remove the service cover and the bottom service cover following [Removing service cover](#), and [Removing bottom service cover and rear cover](#).

When the outdoor unit is installed close to a wall remove the refrigerant piping and move the unit from the wall.

- 2 Collect the refrigerant from the check joint.



NOTE

Check Perform the recovery work at the check joint of piping. If not, the refrigerant remains inside.

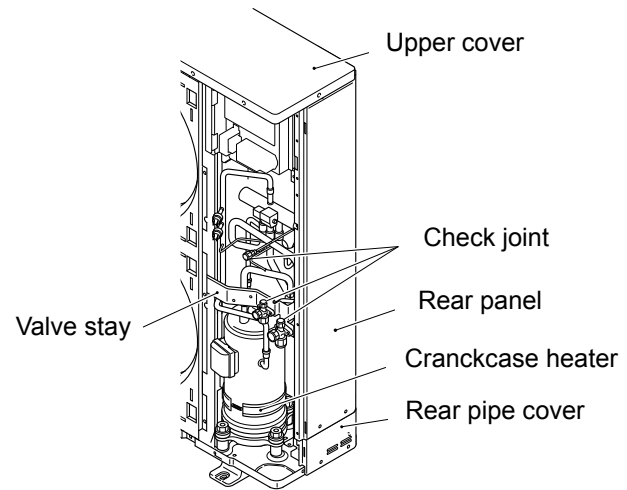

- 3 Open the soundproof cover wrapped around the compressor and remove the terminal box cover of the compressor body. Disconnect the compressor wires in the terminal box and disconnect the thermistor on top of the compressor. Remove the soundproof cover.



NOTE

Check the terminal codes and mark bands when disconnecting the wires. Connecting wires in wrong order at reassembling may result in compressor damage.

- 4 Remove the rubber cap, the upper cover and the thermistor attached on top of the compressor.
- 5 Remove the crankcase heater.

1. Sound-proof cover.

2. Oil heater.

3. Cut part.

A. Direction to remove the cover.

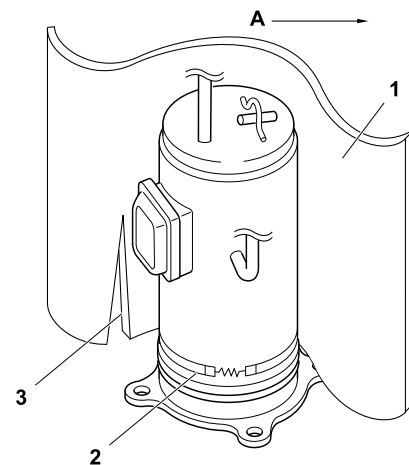

1. Thermistor holder
 2. Holder
 3. Td Thermistor
 4. Thermistor fixing plate
 5. Rubber cap Th Thermistor
 6. Indication of terminal number
 7. Terminal box cover
 8. Compressor
 9. Compressor wires
 10. Fix it with screw
 11. Compressor wires (3 wires)
- A. Details for compressor terminal:

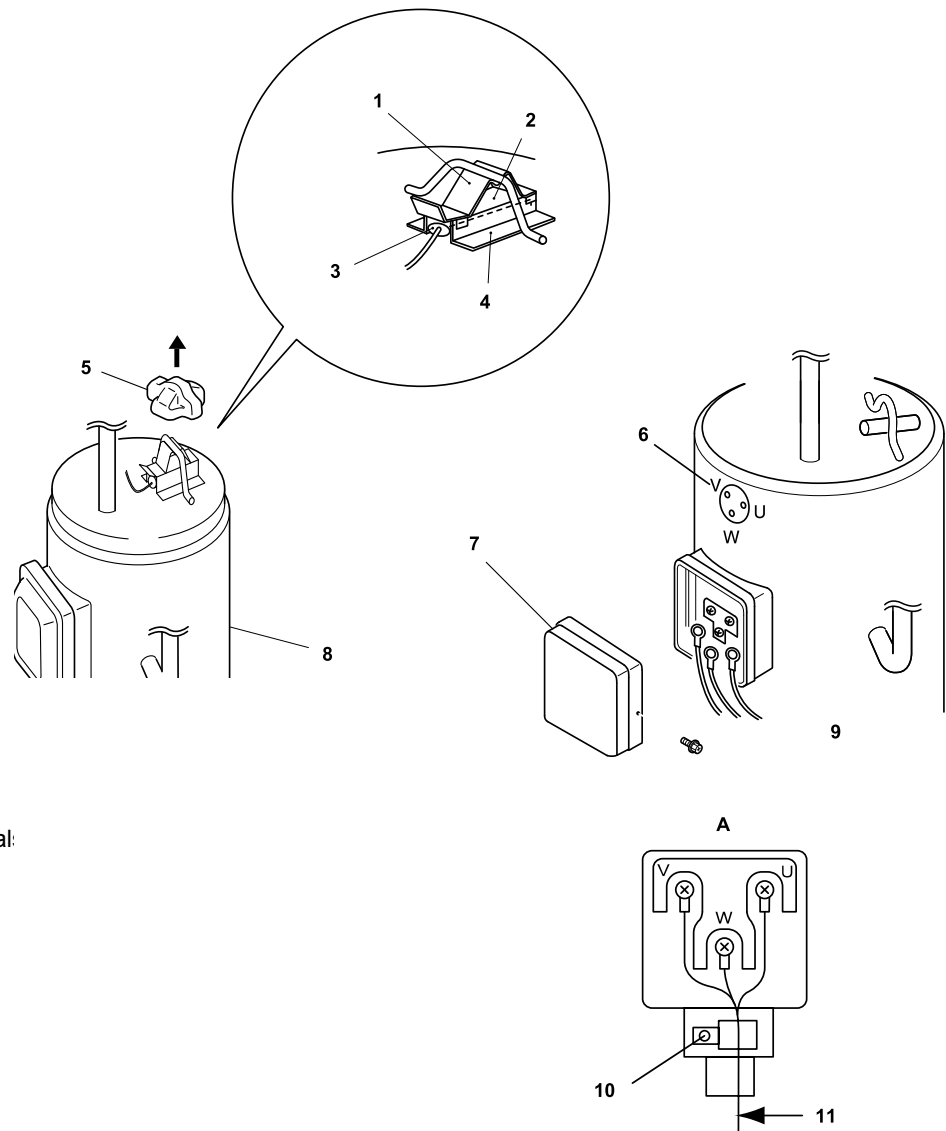

i NOTE

- **Compressor piping must be connected by brazing. MAKE SURE that any flammable material is not around before heating with burner for the oil inside the piping may flame up.**
 - **Do not expose the refrigerant cycle to the atmosphere for a long period to avoid moisture or dust into the cycle. Be sure to replace the compressor immediately after removing. Seal the suction and discharge pipes when the refrigerant cycle is left unattached for a long period.**
 - **Remove the cap of new compressor right before the replacement. Before mounting the compressor seal the suction and discharge pipes with a tape to protect the compressor from dust. Remove the tape when blazing the pipe.**
 - **For piping at reassembling ensure that the compressor terminal numbers and wiring mark band codes are matched. Incorrect wiring numbers may result in inverse rotation and damage of the compressor.**
- 6 Remove the suction pipe and discharge pipe from the compressor.

i NOTE

Be sure to separate the blazing burner flame sufficiently from the wires and electrical components around the brazed part in order to avoid burning.

- 7 Remove 2 nuts which fix the compressor and remove it by lifting it up with inclining forward.

i NOTE

To remove the compressor the liquid stop valve pipe should be moved (bent) to the right side hand. **PAY CLOSE ATTENTION not to crush to break the pipe.**

- 8 When brazing the replaced compressor quickly perform the brazing while the compressor side piping is cooled with wet cloth in order to avoid the brazing material from entering the compressor.

i NOTE

PAY CLOSE ATTENTION not to let the filler metal enter into the compressor which may result in compressor damage.

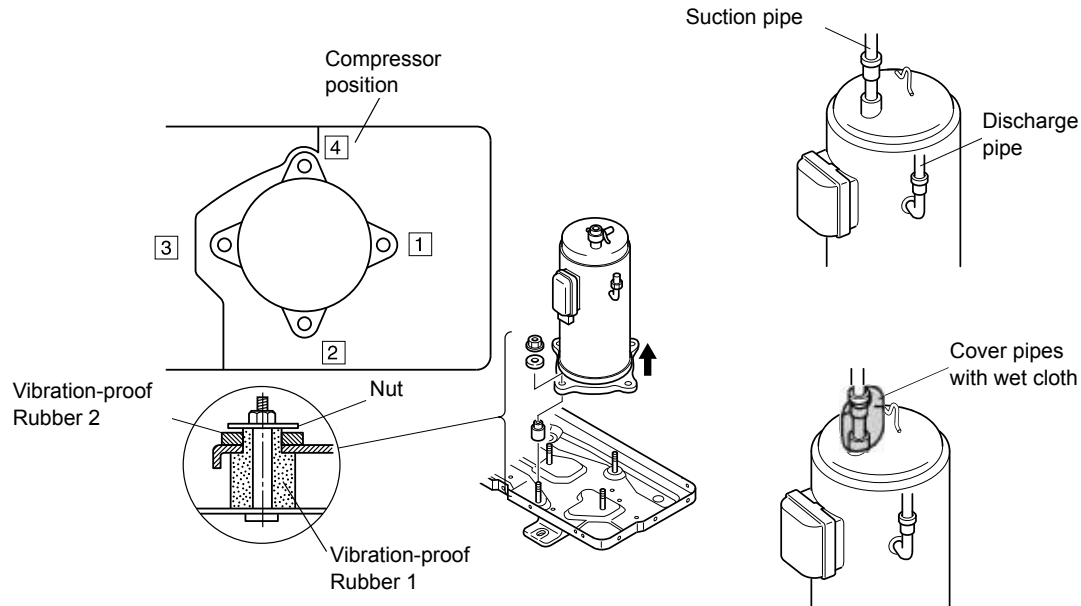

Fixation of the compressor to the bottom plate				
Compressor position	1	2	3	4
Vibration-proof rubber 1	x	x	x	x
Vibration-proof rubber 2	x	x	—	—
Nut	x	x	—	—

- 9 Reassemble the parts in the reverse order of removing procedures.
- Tighten the screws (U V and W) for compressor wires with 2.5 Nm.
 - Fix the wires firmly.
 - Attach the crankcase heater without torsion and gap to the compressor as following figure.

Detail of Spring for Crankcase Heater

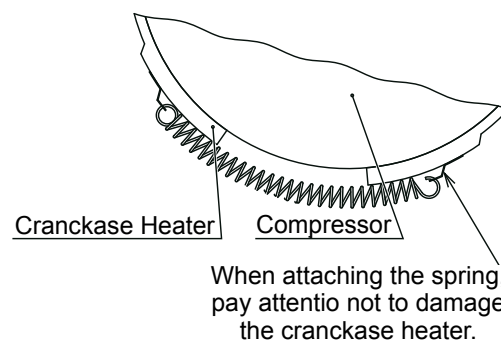

10.3.3.8 Removing High pressure switch and pressure switch for control

- 1 Remove the service cover following [Removing service cover](#) in this chapter.
- 2 Collect the refrigerant from the check joint according to [Removing the compressor](#), in this chapter.

High pressure switch and pressure switch for control

- 1 Disconnect the Faston Terminals of High Pressure Switch and Pressure sensor for PD control.
- 2 Remove the high pressure switch and the pressure switch for control from the brazed part of discharge piping.



NOTE

The procedure (1) is not required when removing the pressure sensor for PD control. However, check to ensure that the connector (CN100) on O.U. PCB1 is disconnected.

Low pressure switch

- 1 Disconnect the Faston Terminals of Low Pressure Switch.
- 2 Remove the low pressure switch from the brazed part of suction piping.

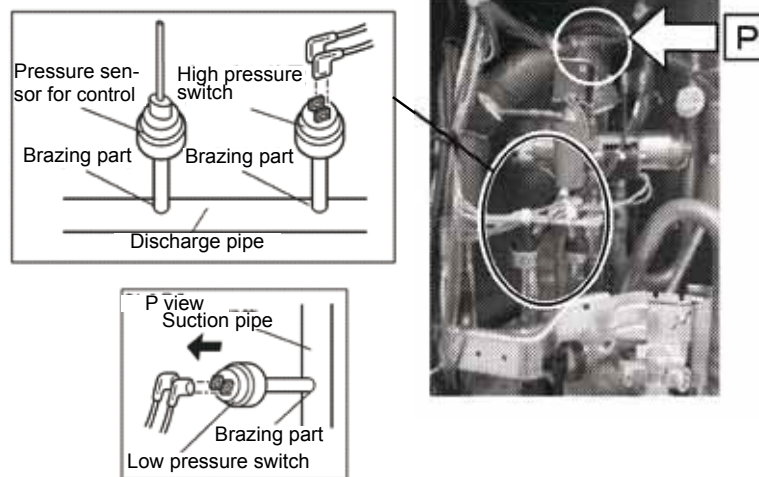

10.3.3.9 Opening electrical box (P-Mounting Plate)

- 1 Remove the service cover following [Removing service cover](#) in this chapter.
- 2 Remove 6 screws which fix the electrical box and open the P plate turning counter clockwise approximately 90°.
 - Check that the LED201 (red) on the inverter PCB (PCB2) is OFF when opening P-mounting plate.

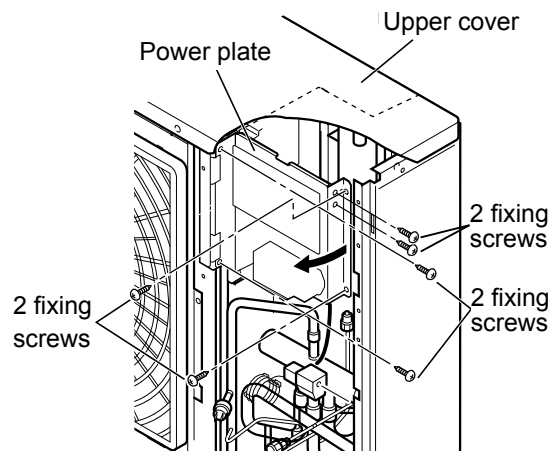

DANGER

DO NOT touch electrical components while the LED201 (Red) or LED1 (Red) are ON to avoid electrical shock. Wait until the LEDs turn off.

10.3.3.10 Removing reversing valve coil

- 1 Remove the service cover following *Removing service cover* in this chapter.



DANGER

DO NOT touch electrical components while the LED1 (Red) is ON to avoid electrical shock. Wait until the LED turns off.

- 2 Remove the connector (PCN100) on the control PCB (PCB1) of the electrical box.
- 3 Remove the reversing valve coil by removing 1 screw fixing the coil.

1. Upper cover.
2. Power Plate.
3. PCN6.
4. Fixing screw for reversing valve coil.
5. Reversing valve coil.
6. Compressor.
7. Reversing valve.
8. Electrical Box.

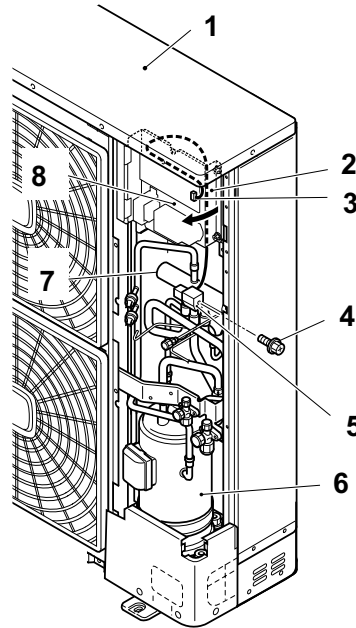

- 4 When reassembling, perform the procedure in the reverse way of removing.



NOTE

Fix the wires by plastic bands to the original position.

10.3.3.11 Removing electronic expansion valve coil

- 1 Remove the service cover, the bottom service cover and the rear cover following [Removing service cover](#) and [Removing bottom service cover and rear cover](#).
- 2 Disconnect the CN5A connector on the control PCB1 of the electrical box.
- 3 Hold the coil of the expansion valve and pull out upward.
It is easier to remove the expansion valve coil if it is rotated while pulling it upward.
- 4 When reassembling after replacing the expansion valve coil, perform the procedure in the reverse way of removing. The expansion valve coil is equipped with a lock mechanism. After attaching the expansion valve coil, rotate it until the sound of locking is heard.



NOTE

Fix the wires by plastic bands to the original position.

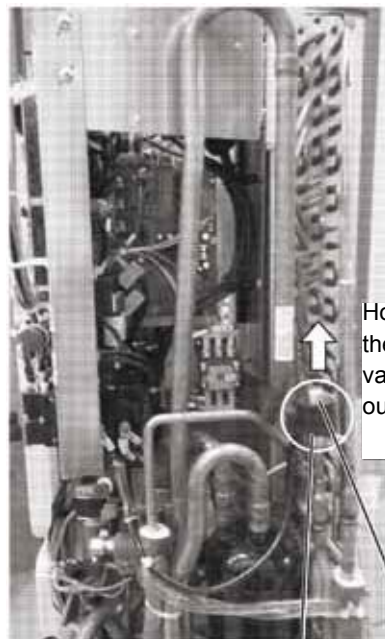

Hold the coil of the expansion valve and pull out upward

Expansion valve coil Release lock



DANGER

DO NOT touch electrical components while the LED201 (Red) or LED1 (Red) are ON to avoid electrical shock. Wait until the LEDs turn off.

10.3.3.12 Removing solenoid valve coil (SVA and SVC)

- 1 Remove the service cover following [Removing service cover](#).
- 2 Open the P-mounting plate. Check to ensure the LED201 (Red) of the inverter PCB (PCB2) is OFF.
- 3 Unplug the connector PCN7 (SVA) and PCN14 (SVC) on O.U. PCB1.
- 4 Remove the fixing screw, and remove the solenoid valve coil (SVA and SVC) upward.
- 5 When reassembling after replacing the solenoid valve coil, perform the procedure in the reverse way of removing.



NOTE

Fix the wires by plastic bands to the original position.



Solenoid valve coil (SVA)

10



DANGER

DO NOT touch electrical components while the LED201 (Red) or LED1 (Red) are ON to avoid electrical shock. Wait until the LEDs turn off.

10.3.3.13 Removing reversing valve

- 1 Remove the service cover, the bottom service cover and the rear cover following *Removing service cover* and *Removing bottom service cover and rear cover*.
- 2 Remove the reversing valve coil according to *Removing Reversing Valve Coil*.
- 3 Recover the refrigerant from check joints according to *Removing Compressor*.
- 4 Remove the reversing valve assemblies from the fixed positions (5 brazing parts).
 - a. Remove the reversing valve and the stop valve with cooling the valve bodies by wet cloth.
 - b. Perform the brazing work with attention not to burn the electrical wirings and the piping insulations.
- 5 Remove reversing valve from the assemblies. (5 brazing parts) At this time, perform the brazing work with cooling the reversing valve body by wet cloth.
- 6 When reassembling after replacing the reversing valves, perform in the reverse procedure of removing.
 - a. Run the lead wires to be located to the original position, and fix them by the plastic band.
 - b. Attach the crankcase heater according to *Removing Compressor*.
- 7 Reassemble the parts in the reverse order of removing procedures.

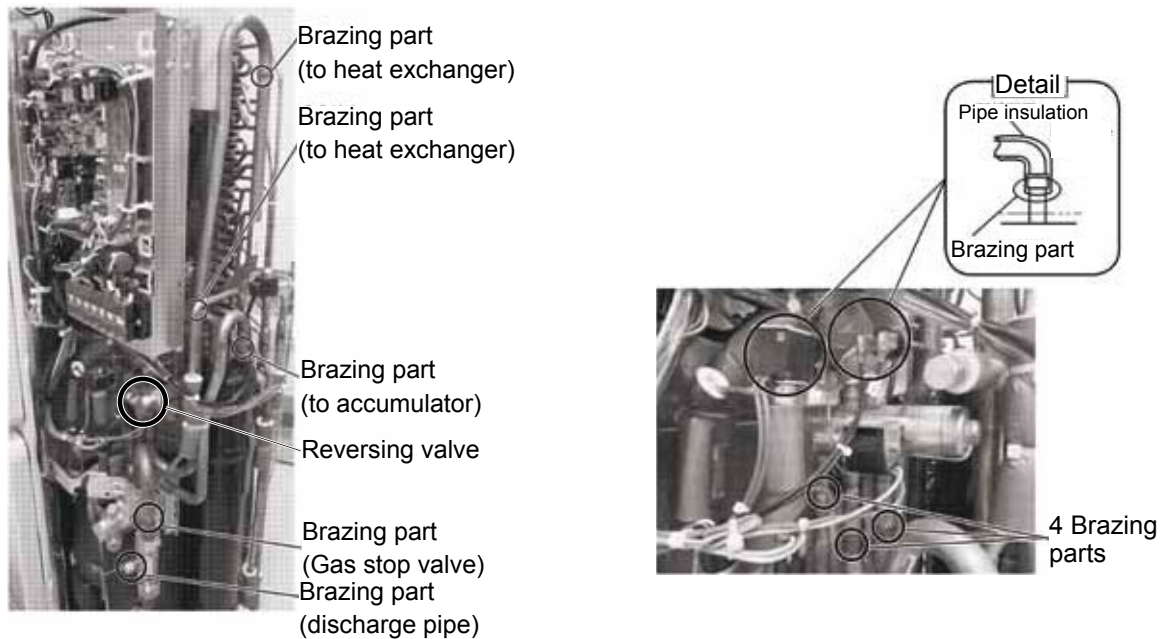

10.3.3.14 Removing Electronic expansion Valve and Solenoid Valve

- 1 Remove the service cover, the bottom service cover and the rear cover following *Removing service cover* and *Removing bottom service cover and rear cover*.
- 2 Recover the refrigerant from check joints according to *Removing Compressor*.
- 3 Remove the coils according to *Removing Electronic Expansion Valve Coil* and *Removing Solenoid Valve Coil*.
- 4 Remove the brazed parts as shown in the figures.
 - Electronic Expansion Valve (EVO) Brazed Parts: 2
 - Solenoid Valve (SVA) Brazed Parts: 2
 - Solenoid Valve (SVC) Brazed Parts: 2
 - a. Remove the electronic expansion valve and the solenoid valve with cooling the valve bodies by wet cloth.
 - b. Perform the brazing work with attention not to burn the electrical wirings and the piping insulations.

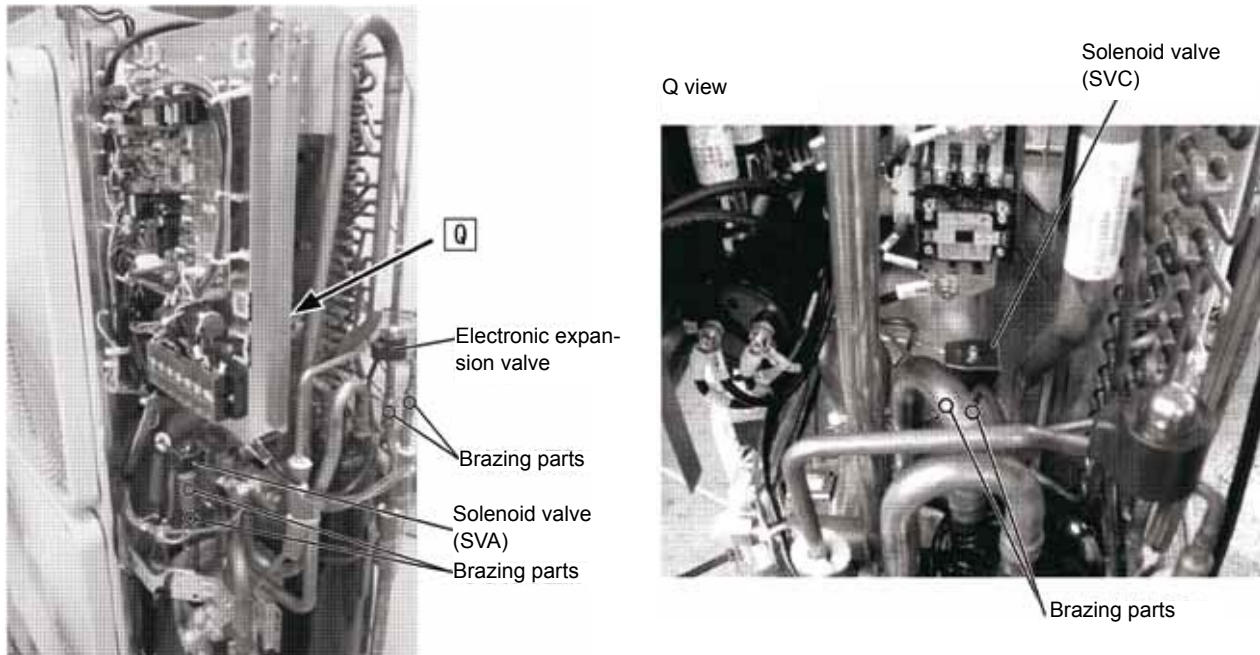

- 5 When reassembling after replacing the valves, perform in the reverse procedure of removing.

**NOTE**

Run the lead wires to be located to the original position, and fix them by the plastic band

10.3.3.15 Removing electrical components

◆ Removing control PCB (PCB1) and relay PCB (PCB3)

- 1 Remove the service cover following [Removing service cover](#).
- 2 Remove all the wiring connected to the control PCB and the relay PCB.



DANGER

DO NOT touch electrical components while the LED1 (Red) is ON to avoid electrical shock. Wait until the LED turns off.

- 3 Remove the 6 holders for each PCB. Clamp the middle part of the holders with long-nose pliers and remove it toward front side.



DANGER

DO NOT touch the electrical components on the PCB. Pay attention not to bend or apply much force onto PCB in order to avoid PCB failure.

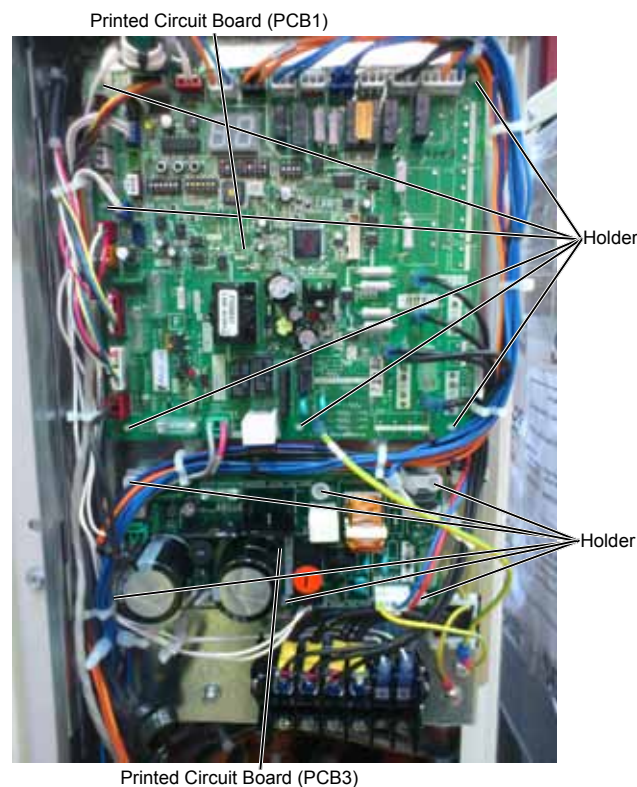
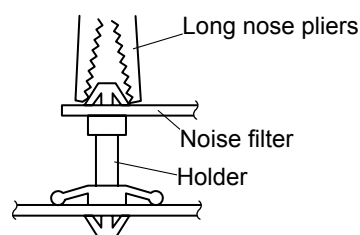

◆ Removing Inverter module

- 1 Remove the service cover following [Removing service cover](#).
- 2 Open the P plate turning counter clockwise approximately 90° following [Opening electrical box \(P plate\)](#).
 - Check that the LED201 (red) on Inverter is OFF when the P plate is opened.



DANGER

DO NOT touch electrical components while the LED201 (Red) or LED1 (Red) are ON to avoid electrical shock. Wait until the LEDs turn off.

- 3 Remove 4 screws M3, remove the bushes and remove the spacers fixing the inverter.



NOTE

When mounting again be sure to place the bushes and spacers.

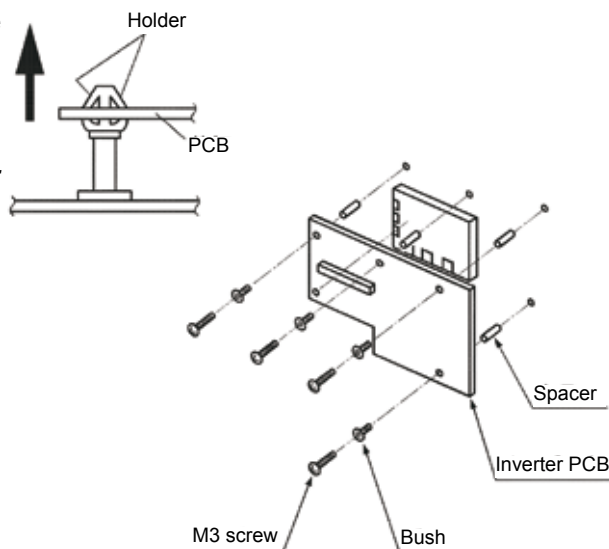

Removing Diode Module (DM)

- 1 Disconnect the wirings of terminal + - U V W on the diode module.
- 2 Remove 2 M5 fixing screws on the diode module.
- 3 Remove the diode module from the electrical box.

- 1: 5 Screws (M5)
- 2: Fixing screw (M5)

**Removing Transistor Module (IPM)**

- 1 Disconnect all the wirings connected to the transistor module.
- 2 Remove the connectors CN2, CN3, CN206, PCN301 and PCN302 from the transistor module.
- 3 Disconnect the wirings of P N U V W on the transistor module.
- 4 Remove 4 M4 fixing screws on the transistor module.
- 5 Remove the transistor module from the electrical box.

1. Screws for transistor module (M4)
2. Screw (M5)
3. PCN301
4. PCN302
5. Screws for PCB (M3)
6. CN3
7. Inverter PCB
8. CN206
9. CN2
10. LED201

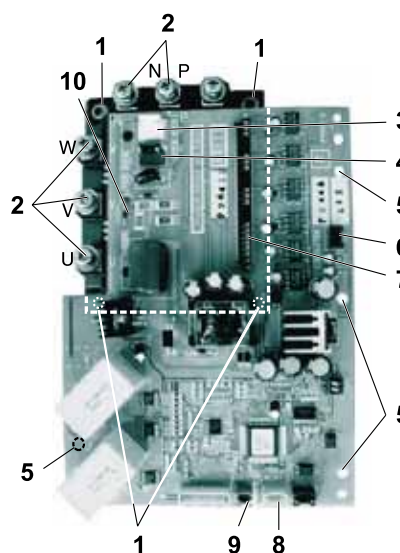

- 6 Reassemble the parts in the reverse order of removing order.

**NOTE**

- To connect wiring at reassembling, ensure that the terminal numbers and wiring mark band codes are matched. If connections are wrong, there is the possibility of wrong operation and to cause damage to electrical parts.
- When attaching the PCB, or when attaching the parts attached to the PCB, pay attention not to clamp any wiring between plates or electrical components.

10.3.3.16 Removing other electrical components

- 1 Remove the service cover following [Removing service cover](#) in this chapter.
- 2 Open the P plate turning counter clockwise approximately 90° following [Opening electrical box \(P plate\)](#).
 - Check that the LED201 (red) on Inverter is OFF when the P plate is opened.



DANGER

DO NOT touch electrical components while the LED201 (Red) is ON to avoid electrical shock. Wait until the LED turns off.

Capacitors

- 1 Remove all the wiring connected to the capacitors.



NOTE

The wires have polar characters. Identify the wire mark band and the indication on the capacitor when connecting wires.

- 2 Remove 3 screws fixing each capacitor.

CMC

- 1 Remove all the wiring connected to CMC.
- 2 Remove 2 screws fixing the CMC.

Reactor

- 1 Remove 4 screws fixing the reactor.

Noise filter

- 1 Remove all the wiring connected to the noise filter.
- 2 Hold the upper part of the 6 holders with the long nose pliers and remove the noise filter.

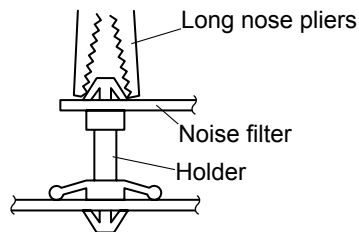

NOTE

When mounting components, be sure to match the wiring connections with the mark band codes.

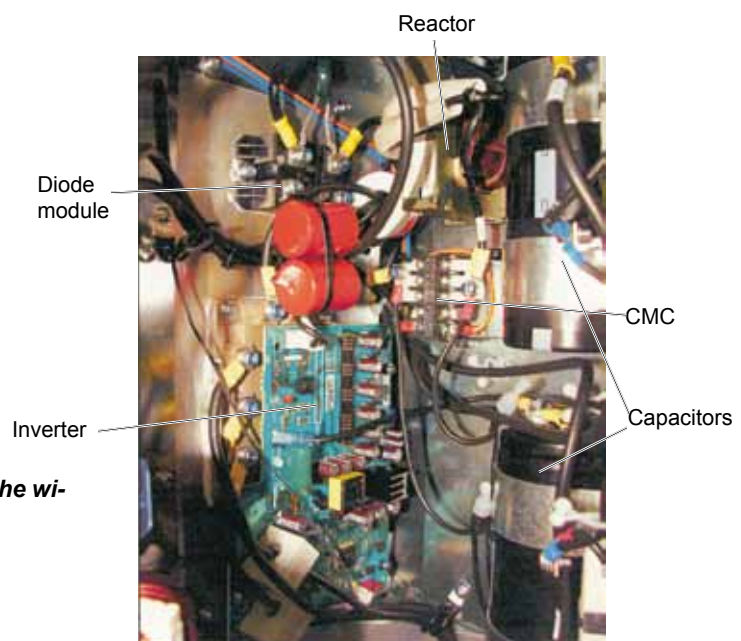

10.3.4 Outdoor Units RAS-12HNP

10.3.4.1 Removing service cover



NOTE

- Follow the procedure below to remove main parts and components. For mounting follow the reverse procedure of removal.
 - Do not expose the refrigerant cycle to the atmosphere for a long period to avoid moisture or dust entering into the cycle. Be sure to replace parts immediately after removing. Seal the refrigerant cycle when left unattached for a long period.
- 1 Remove the 5 fixing screws, slide the service cover downward and remove it.
 - Pay attention not to fall off the service cover.

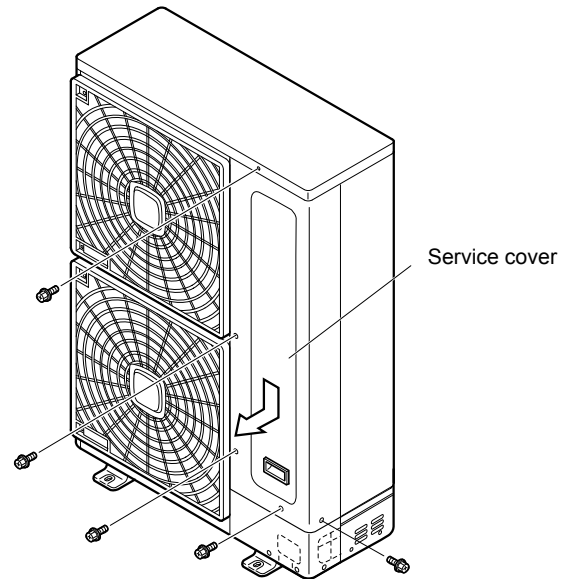

10.3.4.2 Removing air outlet grille

- 1 Remove the 8 fixing screws of the shroud.

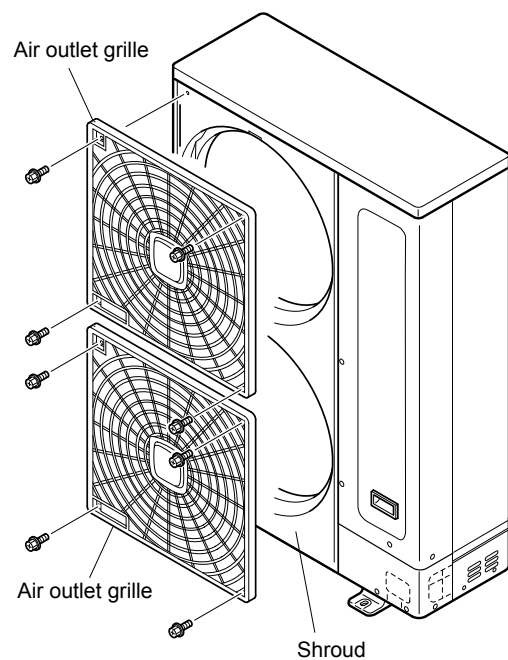

10.3.4.3 Removing upper cover

- 1 Remove 11 screws fixing the upper cover and remove the upper cover upward.

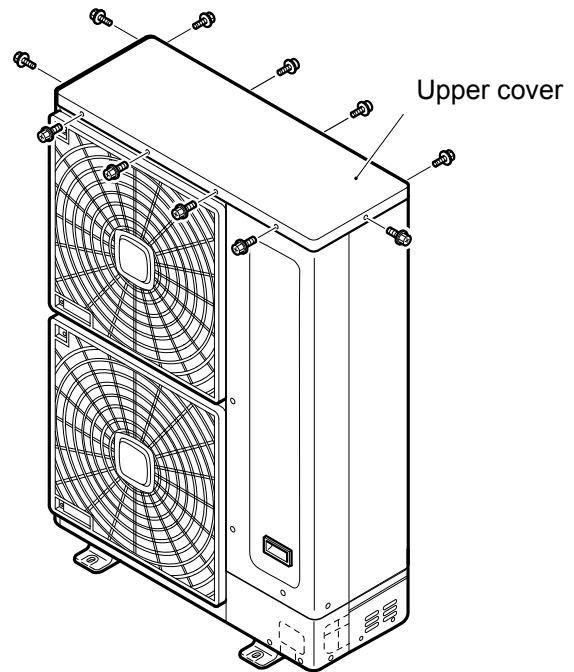
**10.3.4.4 Removing the bottom service cover and rear cover**

- 1 Remove 5 screws fixing the lower part of service cover and remove the lower part of service cover by pulling towards front side.
- 2 Remove the upper cover according to the item [Removing upper cover](#).
- 3 Remove 10 screws fixing panel and remove the rear panel by pulling in the arrow direction.

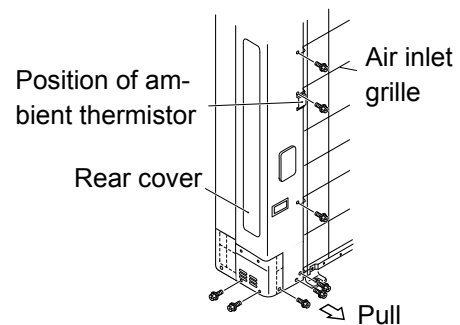
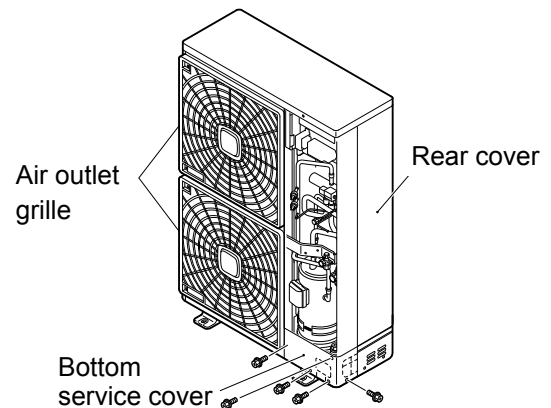

DO NOT touch electrical components while the LED1 (Red) is ON to avoid electrical shock. Wait until the LED turns off.

10.3.4.5 Removing outdoor fan motor

- 1 Remove the service cover following [Removing service cover](#).
- 2 Remove the outlet grille following [Remove outlet grille](#).
- 3 If necessary, remove the upper cover following [Removing upper cover](#).
- 4 To remove the propeller fan remove the cap nut and washer which fix the propeller fan onto the motor shaft. (Use a puller when the propeller fan and motor shaft are fixed too tightly).

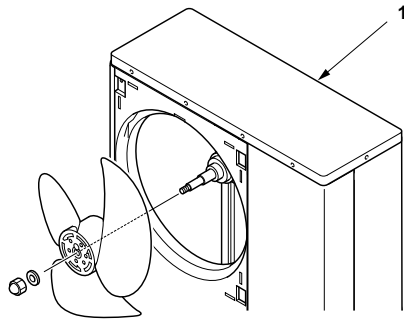

1. Upper cover.

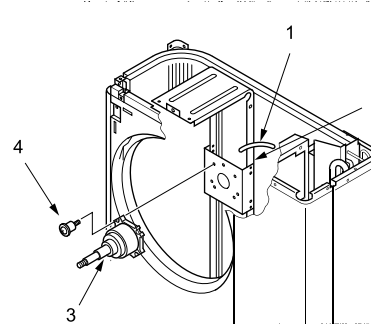

1. Fan motor lead wire.
2. Motor clamp.
3. Motor.
4. Screw with spacer.

- 5 Remove the fan motor connector from PCB in the electrical box.
Cut the plastic tie with nippers which fixes the fan motor lead wire onto the motor clamp.
Remove 4 screws which fix the motor.

Model		RAS-12HNP
Fan Motor Comp. N°	DC Fan Motor	Inverter PCB CN406 (Red)
	AC Fan Motor	inverter PCB PCN404 (White)
Screws for motor fixing.	DC Fan Motor	4 x M6 screw (with spacer)
	AC Fan Motor	4x M8 screws

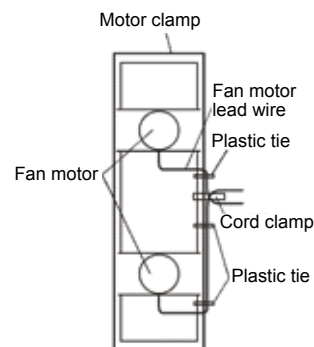

i NOTE

- 1 **To mount the motor be sure to place the lead wire outlet downward.**
(Adjust the propeller fan and shroud not to contact with each other).
- 2 **Fix the motor lead wire onto the motor clamp using a plastic tie as shown in the table on the previous page to avoid obstructing the propeller fan.**
- 3 **Mounting propeller fan:**
Insert the skidding protection part of the fan boss matching with the motor shaft notch; tighten the nut after the shaft screw fully comes out. (Tightening Torque 20 Nm)
- 4 **Connect the motor lead wire to PCB1 of the electrical box.**
(Be sure to match colors of the PCB connectors and motor lead wire connectors).
- 5 **Be sure to attach the outlet grill onto the shroud after replacing the fan motor.**

10.3.4.6 Removing electrical box

- 1 Remove the service cover following [Removing service cover](#).
- 2 Remove the upper cover following [Removing upper cover](#).
- 3 Remove 6 screws which fix the electrical box.
- 4 Pull up and remove the electrical box.

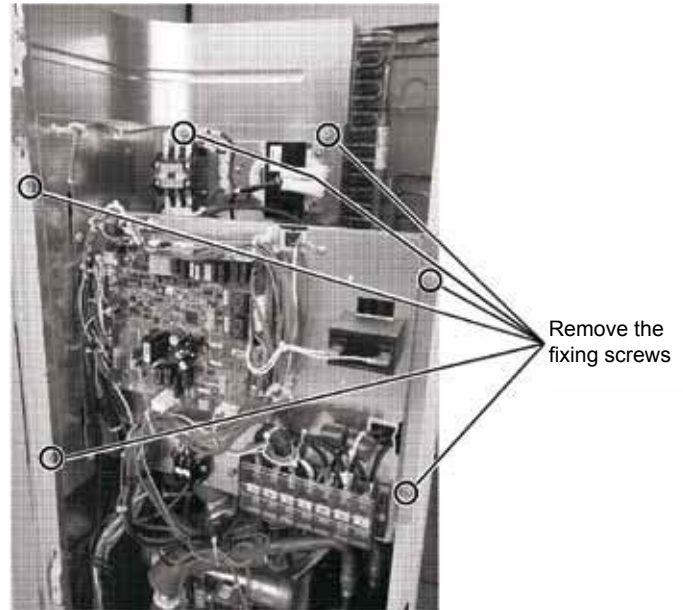

NOTE

The following wiring must be removed to dismantle the electrical box.

1. Remove the reversing valve coil from the reversing valve. : [Removing reversing valve coil](#).
2. Remove the expansion valve coil from the expansion valve. : [Removing electronic expansion valve coil](#).
3. Remove the solenoid valve coil from the solenoid valve. : [Removing solenoid valve coil](#).
4. Remove the Faston terminals of high/low pressure switch and the pressure switch for control from the switch body : [Removing the high pressure switch, the low pressure switch and pressure switch for control](#).
5. Remove all connectors on the control PCB.
6. Remove the compressor wires in the terminal box of the compressor.
7. To remount the electrical box attach the electrical box fitting with the partition plate.
(Insert the radiation fin into the U-notch on the partition plate and place the fin on the fan box side. Then attach the electrical box hooking onto the partition plate).

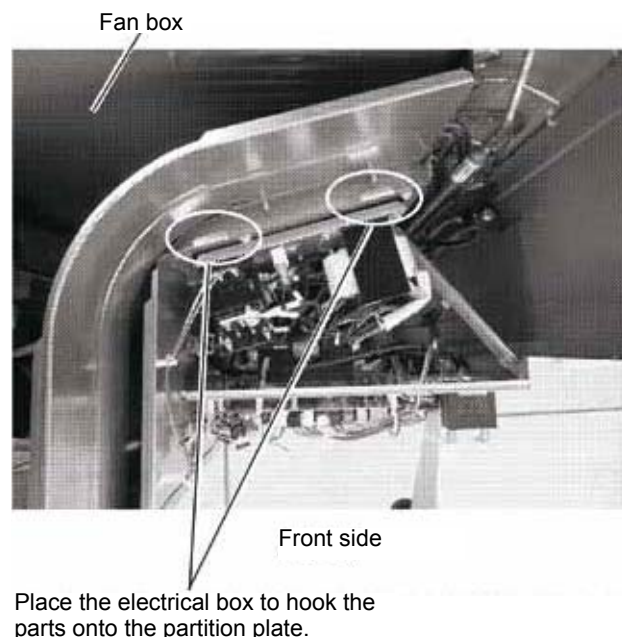
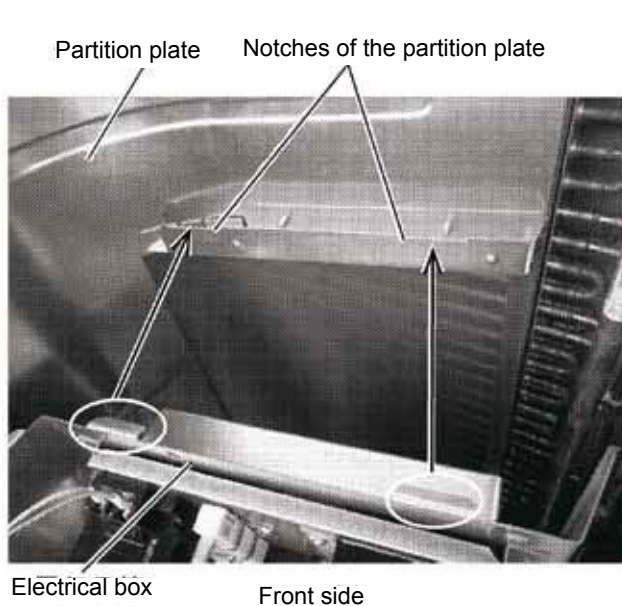

10.3.4.7 Removing the compressor

- 1 Remove the service cover and the bottom service cover following [Removing service cover](#), and [Removing bottom service cover and rear cover](#).

When the outdoor unit is installed close to a wall remove the refrigerant piping and move the unit from the wall.

- 2 Collect the refrigerant from the check joint.



NOTE

Check Perform the recovery work at the check joint of piping. If not, the refrigerant remains inside.

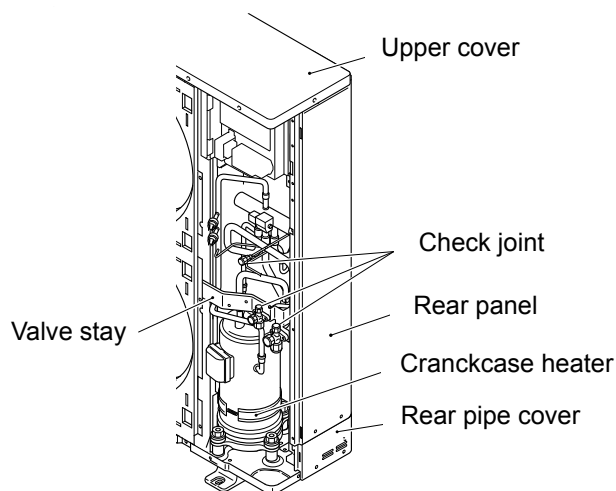

- 3 Open the soundproof cover wrapped around the compressor and remove the terminal box cover of the compressor body. Disconnect the compressor wires in the terminal box and disconnect the thermistor on top of the compressor. Remove the soundproof cover.



NOTE

Check the terminal codes and mark bands when disconnecting the wires. Connecting wires in wrong order at reassembling may result in compressor damage.

- 4 Remove the rubber cap and the thermistor attached on top of the compressor.
- 5 Remove the crankcase heater.

1. Sound-proof cover.

2. Oil heater.

3. Cut part.

A. Direction to remove the cover.

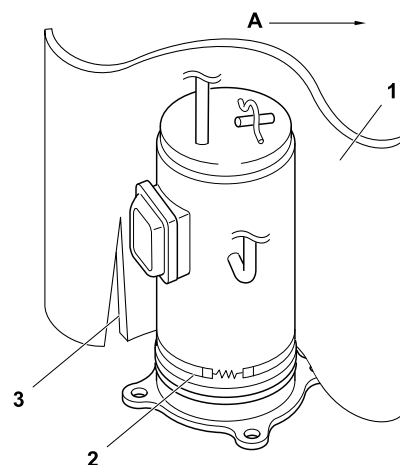

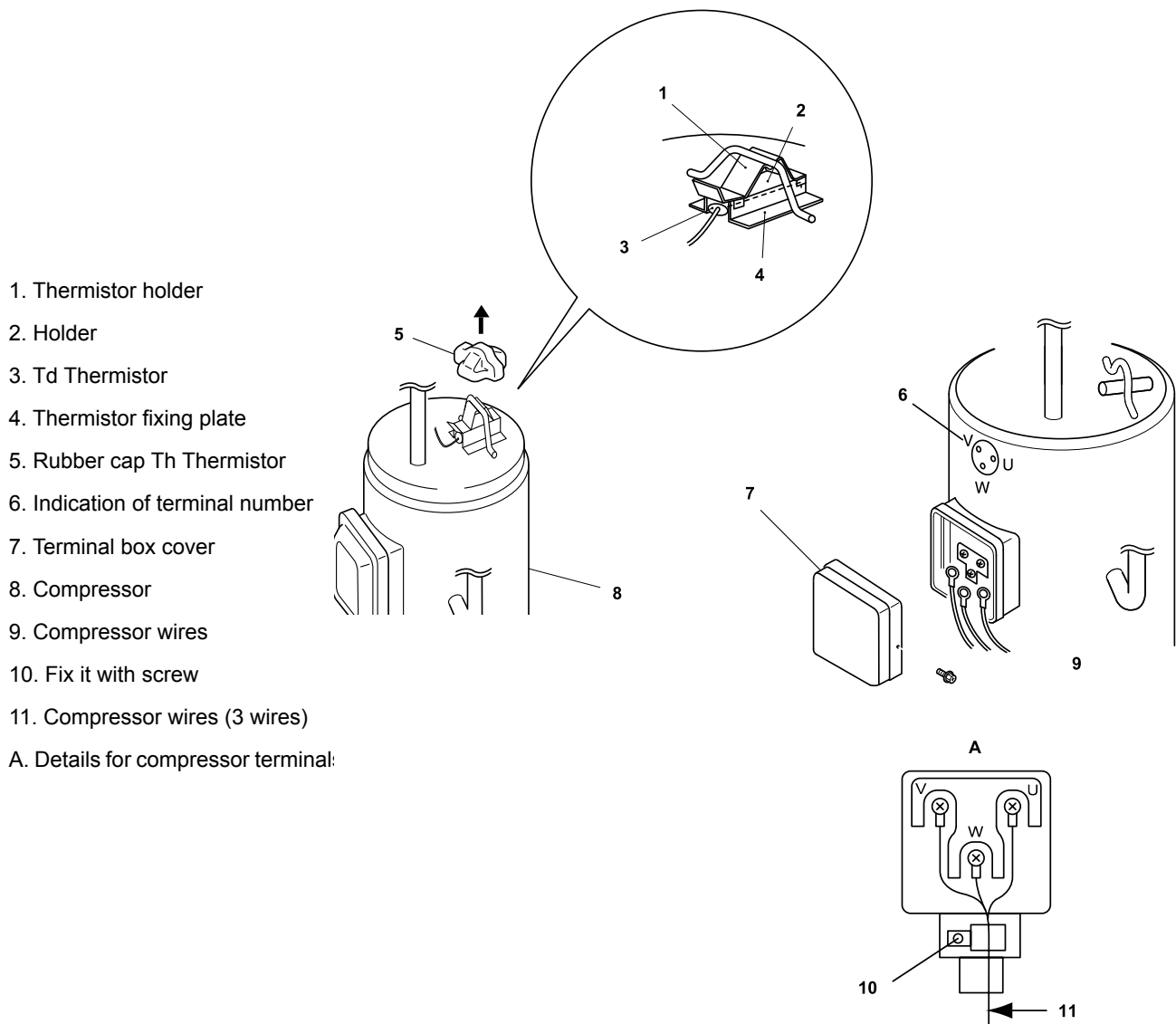

i NOTE

- **Compressor piping must be connected by brazing. MAKE SURE that any flammable material is not around before heating with burner for the oil inside the piping may flame up.**
 - **Do not expose the refrigerant cycle to the atmosphere for a long period to avoid moisture or dust into the cycle. Be sure to replace the compressor immediately after removing. Seal the suction and discharge pipes when the refrigerant cycle is left unattached for a long period.**
 - **Remove the cap of new compressor right before the replacement. Before mounting the compressor seal the suction and discharge pipes with a tape to protect the compressor from dust. Remove the tape when blazing the pipe.**
 - **For piping at reassembling ensure that the compressor terminal numbers and wiring mark band codes are matched. Incorrect wiring numbers may result in inverse rotation and damage of the compressor.**
- 6 Remove the suction pipe and discharge pipe from the compressor.

i NOTE

Be sure to separate the blazing burner flame sufficiently from the wires and electrical components around the brazed part in order to avoid burning.

- 7 Remove 2 nuts which fix the compressor and remove it by lifting it up with inclining forward.

i NOTE

To remove the compressor the liquid stop valve pipe should be moved (bent) to the right side hand. **PAY CLOSE ATTENTION not to crush to break the pipe.**

- 8 When brazing the replaced compressor quickly perform the brazing while the compressor side piping is cooled with wet cloth in order to avoid the brazing material from entering the compressor.

i NOTE

PAY CLOSE ATTENTION not to let the filler metal enter into the compressor which may result in compressor damage.

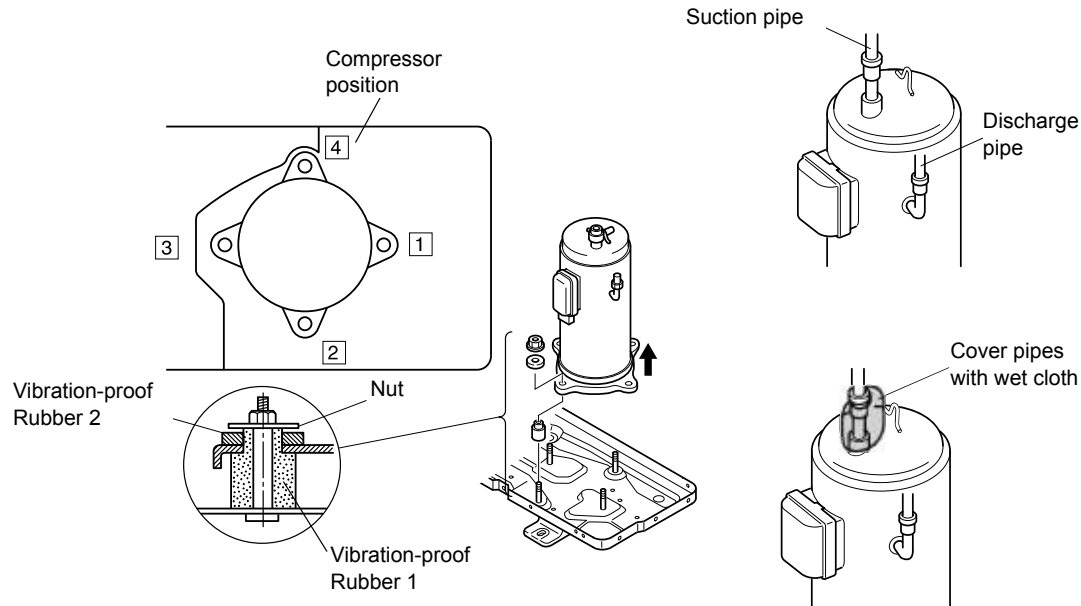

Fixation of the compressor to the bottom plate

Compressor position	1	2	3	4
Vibration-proof rubber 1	x	x	x	x
Vibration-proof rubber 2	x	x	—	—
Nut	x	x	—	—

- 9 Reassemble the parts in the reverse order of removing procedures.

- Tighten the screws (U V and W) for compressor wires with 2.5 Nm.
- Fix the wires firmly.
- Attach the crankcase heater without torsion and gap to the compressor as following figure.

Detail of Spring for Crankcase Heater

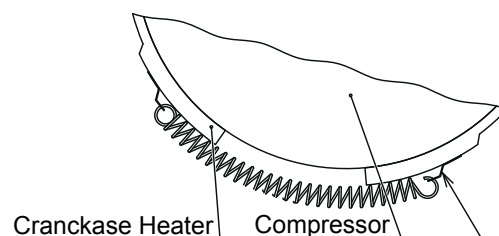

When attaching the spring, pay attention not to damage the crankcase heater.

10.3.4.8 Removing High pressure switch and pressure switch for control

- 1 Remove the service cover following [Removing service cover](#) in this chapter.
- 2 Collect the refrigerant from the check joint according to [Removing the compressor](#), in this chapter.

High pressure switch and pressure switch for control

- 1 Disconnect the Faston Terminals of High Pressure Switch and Pressure sensor for PD control.
- 2 Remove the high pressure switch and the pressure switch for control from the brazed part of discharge piping.



NOTE

The procedure (1) is not required when removing the pressure sensor for PD control. However, check to ensure that the connector (CN100) on O.U. PCB1 is disconnected.

Low pressure switch

- 1 Disconnect the Faston Terminals of Low Pressure Switch.
- 2 Remove the low pressure switch from the brazed part of suction piping.

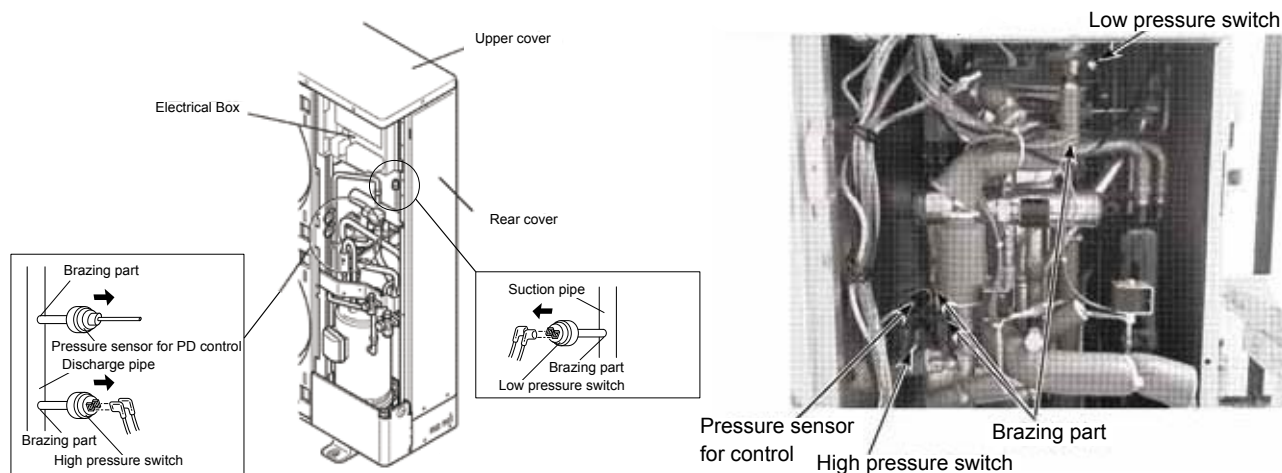

◆ Opening electrical box (P-Mounting Plate)

- 1 Remove the service cover following [Removing service cover](#) in this chapter.
- 2 Remove 5 screws which fix the electrical box and open the P plate turning counter clockwise approximately 90°.
 - Check that the LED201 (red) on the inverter PCB (PCB2) is OFF when opening P-mounting plate.

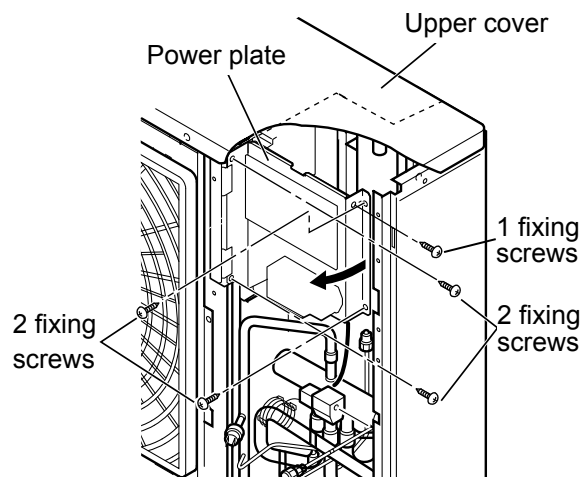

DANGER

DO NOT touch electrical components while the LED201 (Red) or LED1 (Red) are ON to avoid electrical shock. Wait until the LEDs turn off.

10.3.4.9 Removing reversing and solenoid valves coils

- 1 Remove the service cover following *Removing service cover* in this chapter.



DANGER

DO NOT touch electrical components while the LED1 (Red) is ON to avoid electrical shock. Wait until the LED turns off.

- 2 Remove the connectors on the control PCB (PCB1) of the electrical box according to the following picture.
- 3 Remove the valve coils by removing 1 fixing screw for each coil.

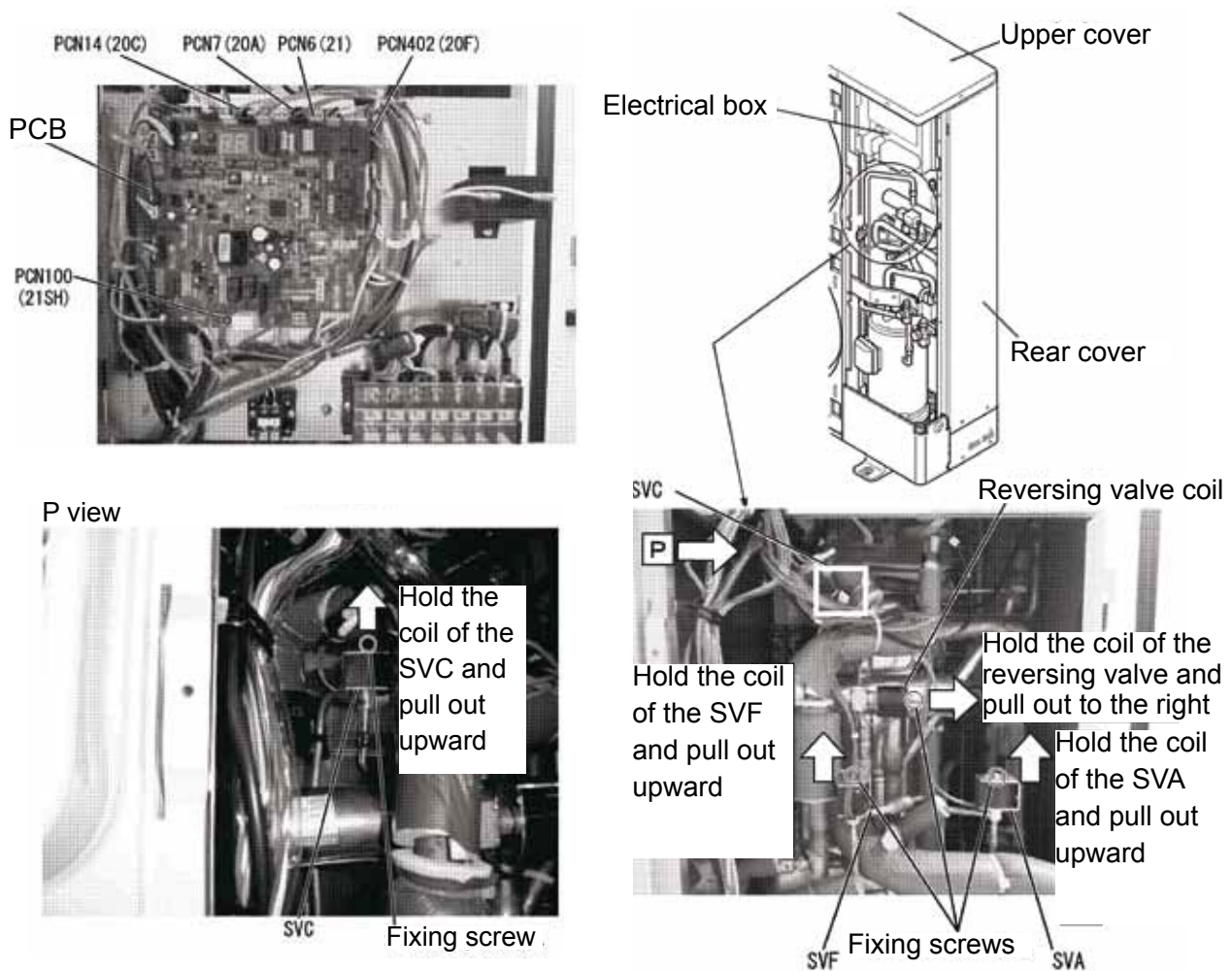

- 4 When reassembling, perform the procedure in the reverse way of removing.



NOTE

Fix the wires by plastic bands to the original position.

10.3.4.10 Removing electronic expansion valve coil

- 1 Remove the service cover, the bottom service cover and the rear cover following [Removing service cover](#) and [Removing bottom service cover and rear cover](#).
- 2 Open the P plate turning counter clockwise approximately 90° following [Opening electrical box \(P plate\)](#).
 - Check that the LED201 (red) on Inverter is OFF when the P plate is opened.



DANGER

DO NOT touch electrical components while the LED201 (Red) or LED1 (Red) are ON to avoid electrical shock. Wait until the LEDs turn off.

- 3 Disconnect the CN5A connector on the control PCB1 of the electrical box.
- 4 Hold the coil of the expansion valve and pull out upward.
It is easier to remove the expansion valve coil if it is rotated while pulling it upward.
- 5 When reassembling after replacing the expansion valve coil, perform the procedure in the reverse way of removing. The expansion valve coil is equipped with a lock mechanism. After attaching the expansion valve coil, rotate it until the sound of locking is heard.



NOTE

Fix the wires by plastic bands to the original position.

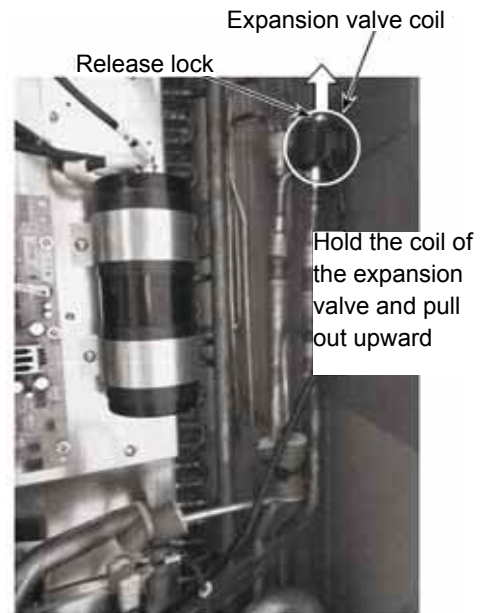

DANGER

DO NOT touch electrical components while the LED201 (Red) or LED1 (Red) are ON to avoid electrical shock. Wait until the LEDs turn off.

10.3.4.11 Removing reversing valve

- 1 Remove the service cover, the bottom service cover and the rear cover following *Removing service cover* and *Removing bottom service cover and rear cover*.
- 2 Remove the reversing valve coil according to *Removing Reversing Valve Coil*.
- 3 Recover the refrigerant from check joints according to *Removing Compressor*.
- 4 Remove the reversing valve assemblies from the fixed positions (5 brazing parts and 1 flare connection).
 - a. Remove the reversing valve and the stop valve with cooling the valve bodies by wet cloth.
 - b. Perform the brazing work with attention not to burn the electrical wirings and the piping insulations.
- 5 Remove reversing valve from the assemblies. (5 brazing parts and 1 flare connection) At this time, perform the brazing work with cooling the reversing valve body by wet cloth.
- 6 When reassembling after replacing the reversing valve, perform in the reverse procedure of removing.
 - a. Run the lead wires to be located to the original position, and fix them by the plastic band.
 - b. Attach the crankcase heater according to *Removing Compressor*.
- 7 Reassemble the parts in the reverse order of removing procedures.

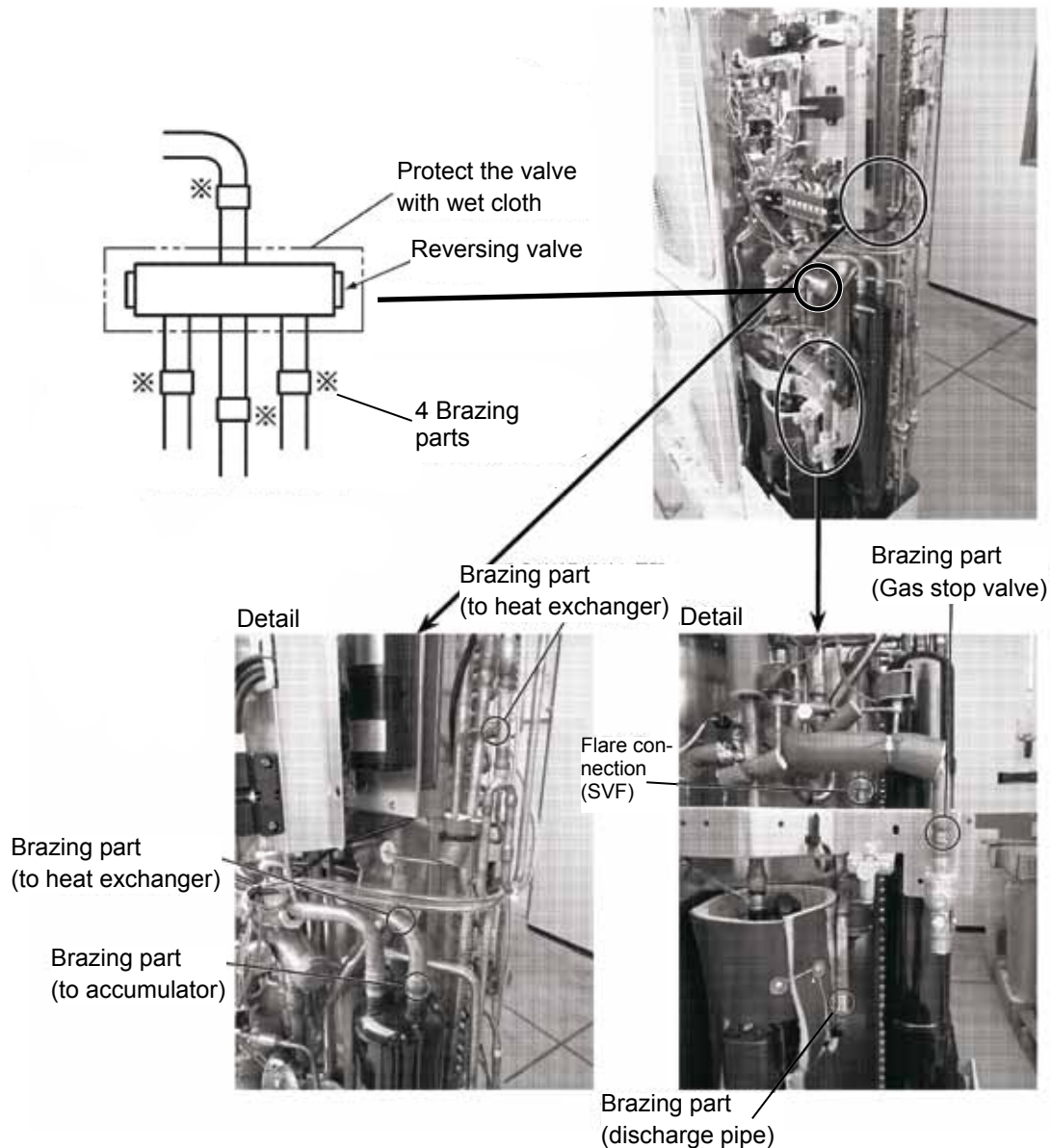

10.3.4.12 Removing Electronic expansion Valve and Solenoid Valve

- 1 Remove the service cover, the bottom service cover and the rear cover following *Removing service cover* and *Removing bottom service cover and rear cover*.
- 2 Recover the refrigerant from check joints according to *Removing Compressor*.
- 3 Remove the coils according to *Removing Electronic Expansion Valve Coil* and *Removing Reversing and Solenoid Valves Coils*.

Removing electronic expansion valve

- 1 Remove the brazed parts as shown in the figure.
 - Electronic Expansion Valve (EVO) Brazed Parts: 2
 - a. Remove the electronic expansion valve with cooling the valve bodies by wet cloth.
 - b. Perform the brazing work with attention not to burn the electrical wirings and the piping insulations.

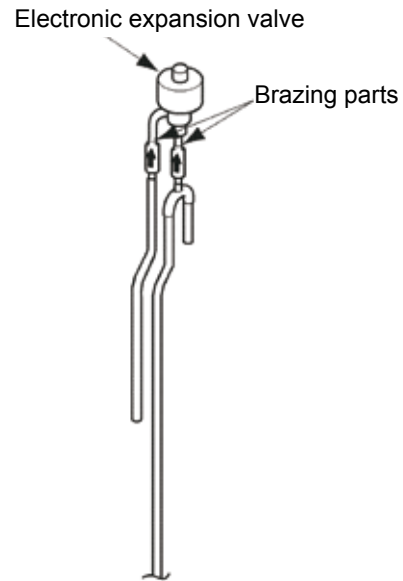

- 2 When reassembling after replacing the valves, perform in the reverse procedure of removing.



NOTE

Run the lead wires to be located to the original position, and fix them by the plastic band.

Removing solenoid valves

1 Remove the brazed parts and the flare connections as shown in the figures.

- Solenoid Valve (SVA) Brazed Parts: 2
- Solenoid Valve (SVC) Brazed Parts: 2
- Solenoid Valve (SVF) Flare connections: 2

- a. Remove the solenoid valves with cooling the valve bodies by wet cloth.
- b. Perform the brazing work with attention not to burn the electrical wirings and the piping insulations.
- c. Perform the flare connection work using two spanners to avoid twisting pipes.

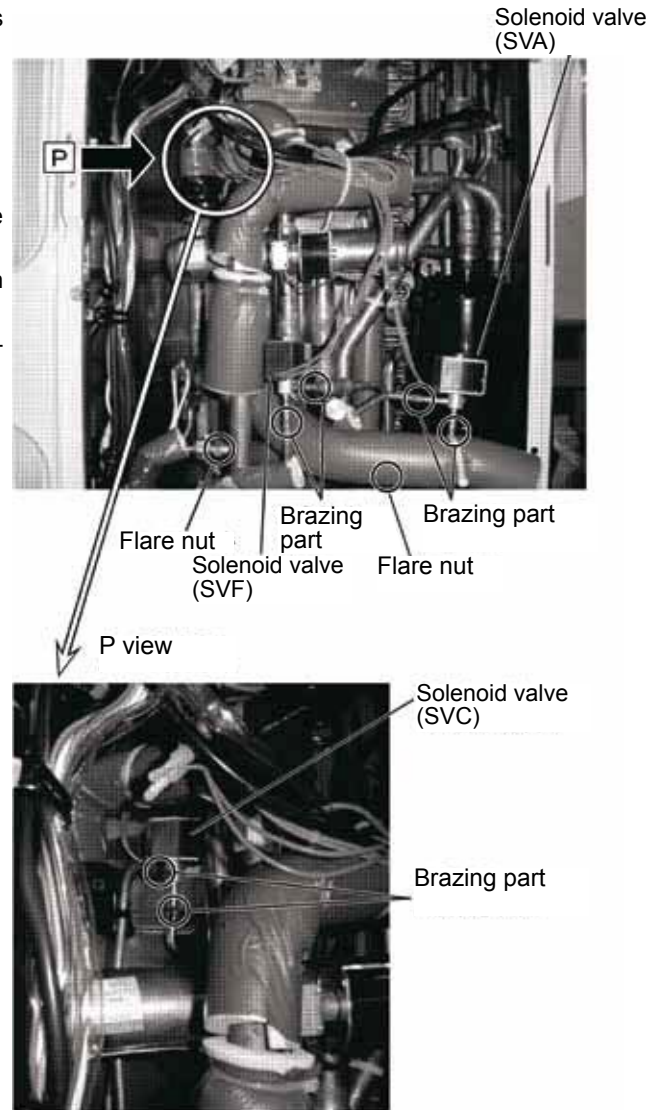

2 When reassembling after replacing the valves, perform in the reverse procedure of removing.

i NOTE

Run the lead wires to be located to the original position, and fix them by the plastic band

10.3.4.13 Removing electrical components

◆ Removing control PCB (PCB1)

- 1 Remove the service cover following [Removing service cover](#).
- 2 Remove all the wiring connected to the control PCB.



DANGER

DO NOT touch electrical components while the LED1 (Red) is ON to avoid electrical shock. Wait until the LED turns off.

- 3 Remove the 6 holders. Clamp the middle part of the holders with long-nose pliers and remove it toward front side.



DANGER

DO NOT touch the electrical components on the PCB. Pay attention not to bend or apply much force onto PCB in order to avoid PCB failure.

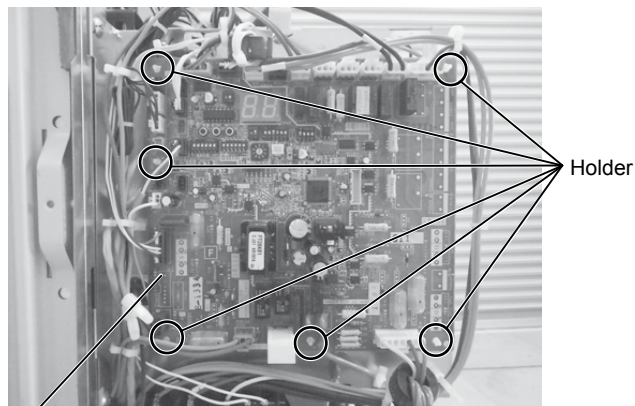

Printed Circuit Board (PCB1)

◆ Removing Inverter module

- 1 Remove the service cover following [Removing service cover](#).
- 2 Open the P plate turning counter clockwise approximately 90° following [Opening electrical box \(P plate\)](#).
 - Check that the LED201 (red) on Inverter is OFF when the P plate is opened.



DANGER

DO NOT touch electrical components while the LED201 (Red) or LED1 (Red) are ON to avoid electrical shock. Wait until the LEDs turn off.

- 3 Remove 4 screws M3, remove the bushes and remove the spacers fixing the inverter.



NOTE

When mounting again be sure to place the bushes and spacers.

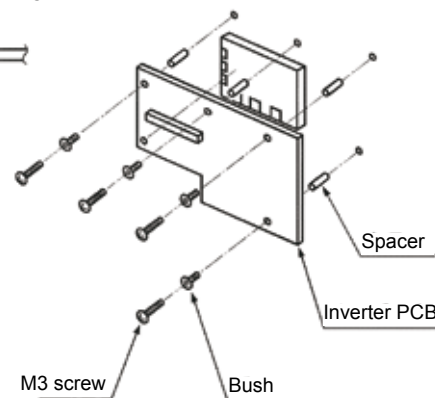
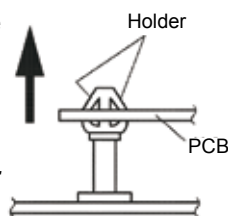

Removing Diode Module (DM)

- 1 Disconnect the wirings of terminal + - U V W on the diode module.
- 2 Remove 2 M5 fixing screws on the diode module.
- 3 Remove the diode module from the electrical box.

- 1: 5 Screws (M5)
- 2: Fixing screw (M5)



Removing Transistor Module (IPM)

- 1 Disconnect all the wirings connected to the transistor module.
- 2 Remove the connectors CN2, CN3, CN206, PCN301 and PCN302 from the transistor module.
- 3 Disconnect the wirings of P N U V W on the transistor module.
- 4 Remove 4 M4 fixing screws on the transistor module.
- 5 Remove the transistor module from the electrical box.

1. Screws for transistor module (M4)
2. Screw (M5)
3. PCN301
4. PCN302
5. Screws for PCB (M3)
6. CN3
7. Inverter PCB
8. CN206
9. CN2
10. LED201

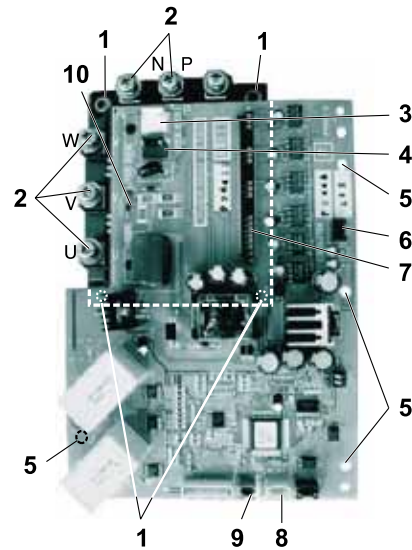

- 6 Reassemble the parts in the reverse order of removing order.

NOTE

Identify terminal with the mark band when reassembling to avoid incorrect wiring.

10.3.4.14 Removing other electrical components

- 1 Remove the service cover following [Removing service cover](#) in this chapter.
- 2 Open the P plate turning counter clockwise approximately 90° following [Opening electrical box \(P plate\)](#).
 - Check that the LED201 (red) on Inverter is OFF when the P plate is opened.



DANGER

DO NOT touch electrical components while the LED201 (Red) is ON to avoid electrical shock. Wait until the LED turns off.

Capacitors

- 1 Remove all the wiring connected to the capacitors.



NOTE

The wires have polar characters. Identify the wire mark band and the indication on the capacitor when connecting wires.

- 2 Remove 2 screws fixing the capacitors.

CMC

- 1 Remove all the wiring connected to CMC.
- 2 Remove 3 screws fixing the CMC.

Reactor

- 1 Remove 4 screws fixing the reactor.

Noise filter

- 1 Remove all the wiring connected to the noise filter.
- 2 Hold the upper part of the 6 holders with the long nose pliers and remove the noise filter.

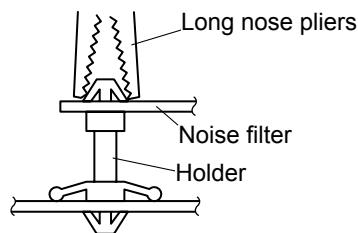

NOTE

- **To connect wiring at reassembling, ensure that the terminal numbers and wiring mark band codes are matched. If connections are wrong, there is the possibility of wrong operation and to cause damage to electrical parts.**
- **From the Power Wires (U Phase, V Phase, W Phase) of Inverter Compressor (MC1), please make sure that the 2 wires of U Phase and V Phase pass through the current sensors (CTU • CTV) of Inverter PCB (PWB3). Also make sure that the Power Wire of U Phase is connected to the U Phase side of current sensor (CTU), and that V Phase is connected to the V Phase side of current sensor (CTV). If the combination is wrong, it could be a cause of wrong operation and damage.**
- **When attaching the PCB, or when attaching the parts attached to the PCB, pay attention not to clamp any wiring between plates or electrical components.**
- **Screws, Bushes and Collars are used to fix the Inverter PCB. Please use Bushes and Collars without fault when attaching the Inverter PCB. Failure to do so may cause wrong operation.**
- **When replacing the Control PCB, please set the Dip Switches with the same configuration as the PCB before replacement. Wrong settings may cause wrong operation. Also, please confirm the replacement instructions supplied with the PCB sold as a service part.**
- **Do not apply too much force to the electrical parts mounted on the PCB or to the PCB itself. It may cause failure of the PCB.**

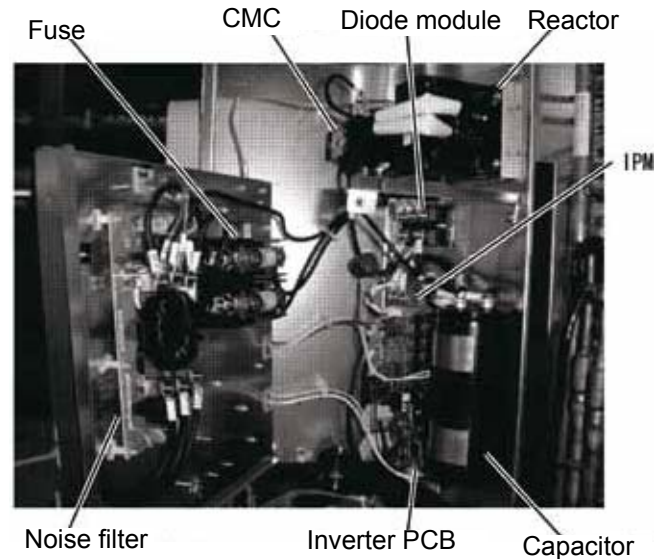

10.4 Servicing for Standard Series

10.4.1 Outdoor Units RAS-(4-6)H(V)NCE

10.4.1.1 Removing service cover



NOTE

- Follow the procedure below to remove main parts and components. For mounting follow the reverse procedure of removal.
- Do not expose the refrigerant cycle to the atmosphere for a long period to avoid moisture or dust entering into the cycle. Be sure to replace parts immediately after removing. Seal the refrigerant cycle when left unattached for a long period.

- 1 Pull downward and remove the service cover after removing 3 upper and lower fixing screws.
 - Pay attention not to drop the service cover.

1. Service cover.

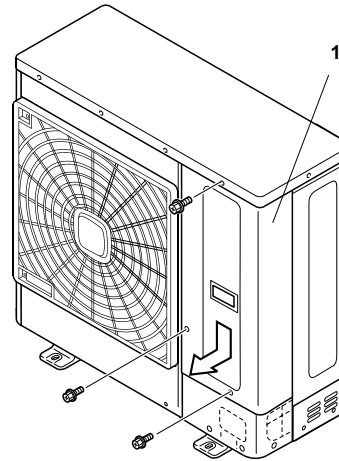

10.4.1.2 Remove outlet grille

- 1 Remove 4 screws which fix the outlet grille.

1. Air outlet grille.
2. Shroud.

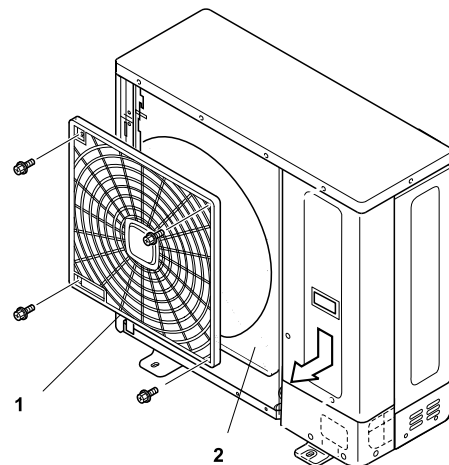

10.4.1.3 Removing upper cover

- 1 Remove the upper cover upward after removing 9 fixing screws.

1. Upper cover.

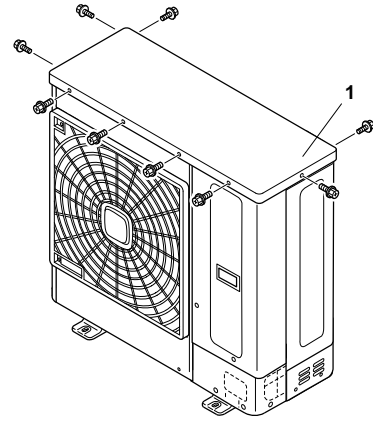

10.4.1.4 Removing bottom service cover and rear cover

- 1 Remove 5 screws which fix the bottom service cover. Pull and remove the bottom service cover.
- 2 Remove the upper cover following [Removing upper cover](#).
- 3 Remove 9 screws which fix the rear cover. Pull backward and remove the rear cover.

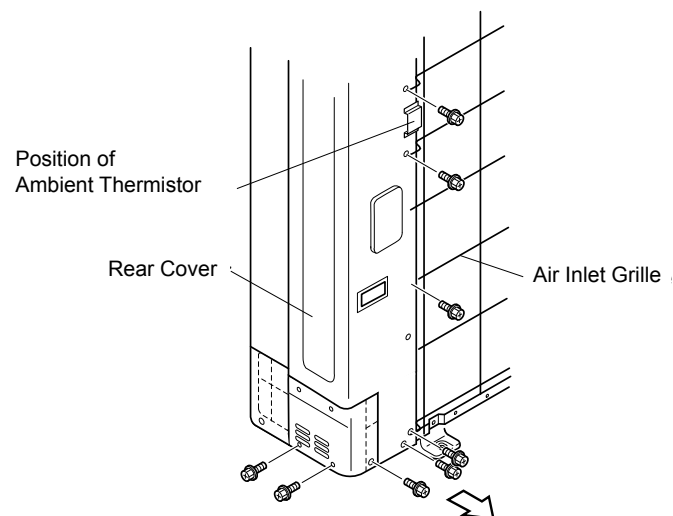
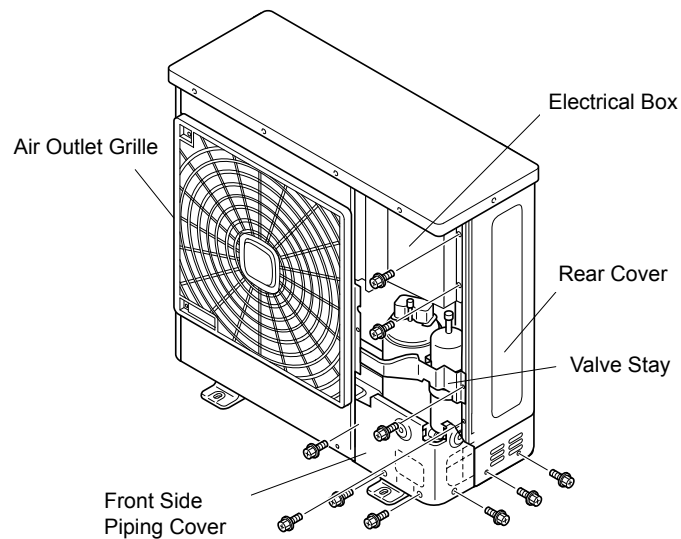

NOTE

Pay attention that the screw length for the ambient thermistor differs from other fixing screws.

10.4.1.5 Removing outdoor fan motor

- 1 Remove the service cover following [Removing service cover](#).
- 2 Remove the outlet grille following [Remove outlet grille](#).
- 3 Remove the upper cover following [Removing upper cover](#).
- 4 To remove the propeller fan remove the cap nut and washer which fix the propeller fan onto the motor shaft. (Use a puller when the propeller fan and motor shaft are fixed too tightly).

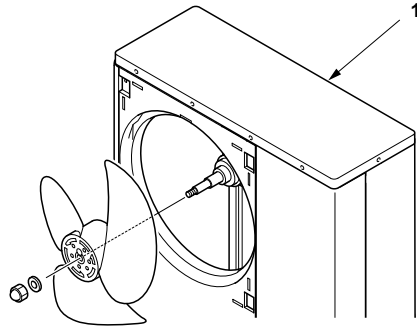

1. Upper cover.

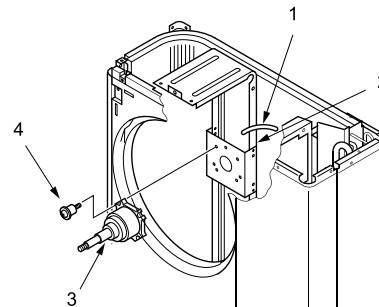

1. Fan motor lead wire.
2. Motor clamp.
3. Motor.
4. Screw with spacer.

- 5 Remove the fan motor connector from PCB in the electrical box.
Cut the plastic tie with nippers which fixes the fan motor lead wire onto the motor clamp.
Remove 4 screws which fix the motor.

Model	RAS-(4-6)H(V)NCE
Connector pin location	Inverter PCB - CN202
Motor fixing screws	4x M5 screws

1. Motor clamp.
2. Plastic tie.
3. Wire.
4. Motor.



NOTE

- 1 **To mount the motor be sure to place the lead wire outlet downward.**
(Adjust the propeller fan and shroud not to contact with each other).
- 2 **Fix the motor lead wire onto the motor clamp using a plastic tie as shown in the table on the previous page to avoid obstructing the propeller fan.**
- 3 **Mounting propeller fan:**
Insert the skidding protection part of the fan boss matching with the motor shaft notch; tighten the nut after the shaft screw fully comes out. (Tightening Torque 20 Nm)
- 4 **Connect the motor lead wire to PCB1 of the electrical box.**
(Be sure to match colors of the PCB connectors and motor lead wire connectors).
- 5 **Be sure to attach the outlet grill onto the shroud after replacing the fan motor.**

10.4.1.6 Removing electrical box

- 1 Remove the service cover following [Removing service cover](#).
- 2 Remove the upper cover following [Removing upper cover](#).
- 3 Remove 4 screws which fix the electrical box.
- 4 Pull up and remove the electrical box.

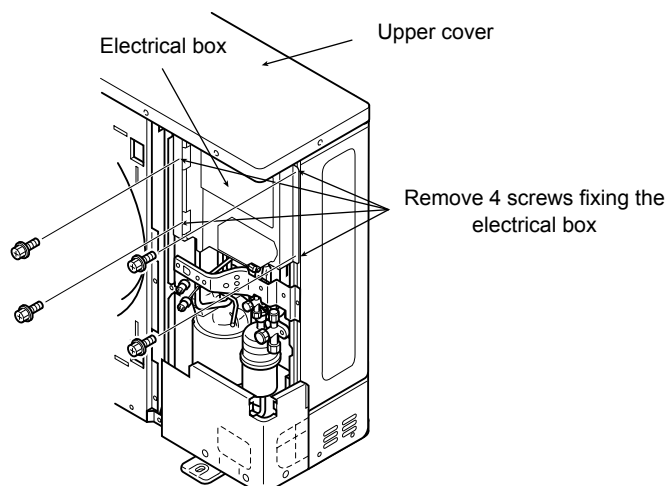

NOTE

The following wiring must be removed to dismount the electrical box.

1. Remove the reversing valve coil from the reversing valve. : [Removing reversing valve coil](#).
2. Remove the expansion valve coil from the expansion valve. : [Removing electronic expansion valve coil](#).
3. Remove the solenoid valve coil from the solenoid valve. : [Removing solenoid valve coil](#).
4. Remove the Faston terminals of high/low pressure switch and the pressure switch for control from the switch body : [Removing the high pressure switch, low pressure switch and pressure switch for control](#).
5. Remove all connectors on the control PCB.
6. Remove the compressor wires in the terminal box of the compressor.
7. To remount the electrical box attach the electrical box fitting with the partition plate.
(Insert the radiation fin into the U-notch on the partition plate and place the fin on the fan box side. Then attach the electrical box hooking onto the partition plate).



Front side

Original position

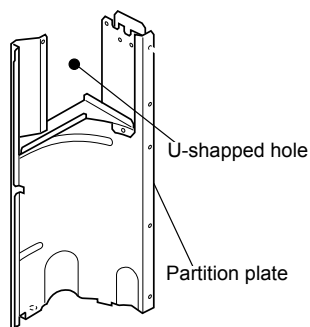

U-shaped hole

Partition plate

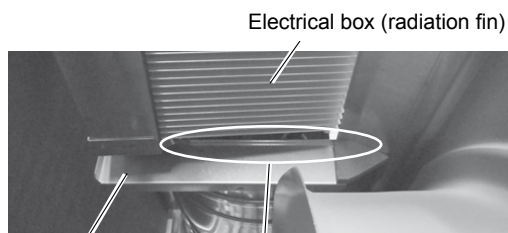

Front side

Partition plate

Place the electrical box (radiation fin) in front of the partition plate.
(Refer to the original position)

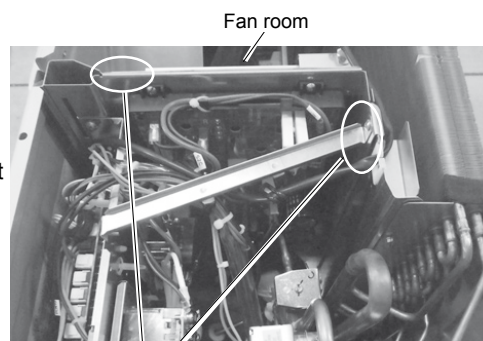

Front side

Fan room

Place the electrical box to hook the parts onto the partition plate.

10.4.1.7 Removing the compressor

◆ RAS-4H(V)NCE

- 1 Remove the service cover upper cover bottom service cover and rear cover following [Removing service cover](#), [Removing upper cover](#), and [Removing bottom service cover and rear cover](#). When the outdoor unit is installed close to a wall remove the refrigerant piping and move the unit from the wall.
- 2 Remove the electrical box following [Removing electrical box](#).
- 3 Collect the refrigerant from the check joint.
- 4 Remove the valve stay.

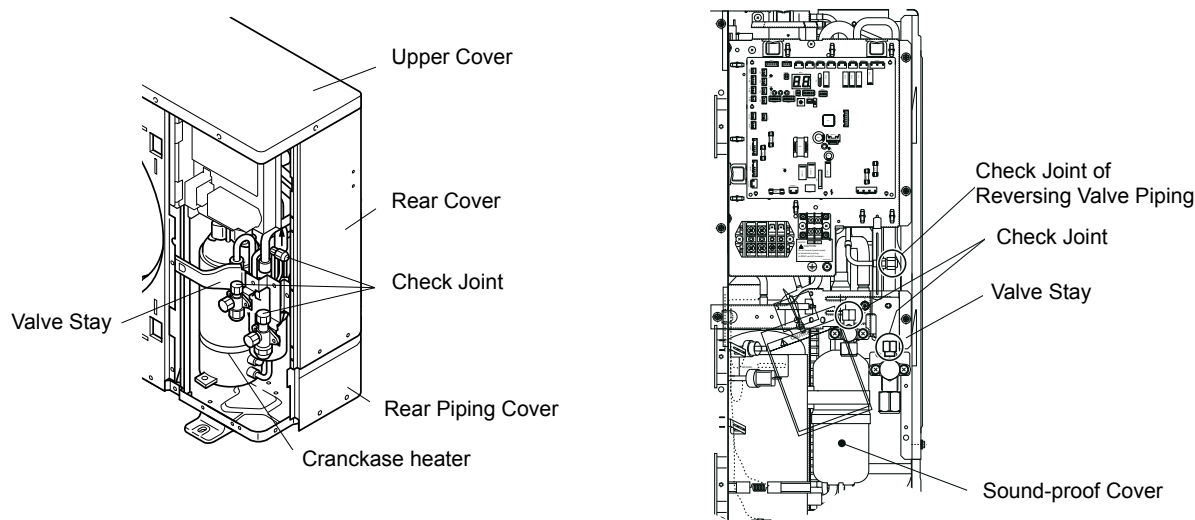

i NOTE

Check Perform the recovery work at the check joint of piping. If not, the refrigerant remains inside.

- 5 Open the soundproof cover wrapped around the compressor and remove the terminal box cover of the compressor body. Disconnect the compressor wires in the terminal box and remove the thermistor on top of the compressor. Remove the soundproof cover.

i NOTE

Check the terminal codes and mark bands when disconnecting the wires. Connecting wires in wrong order at reassembling may result in compressor damage.

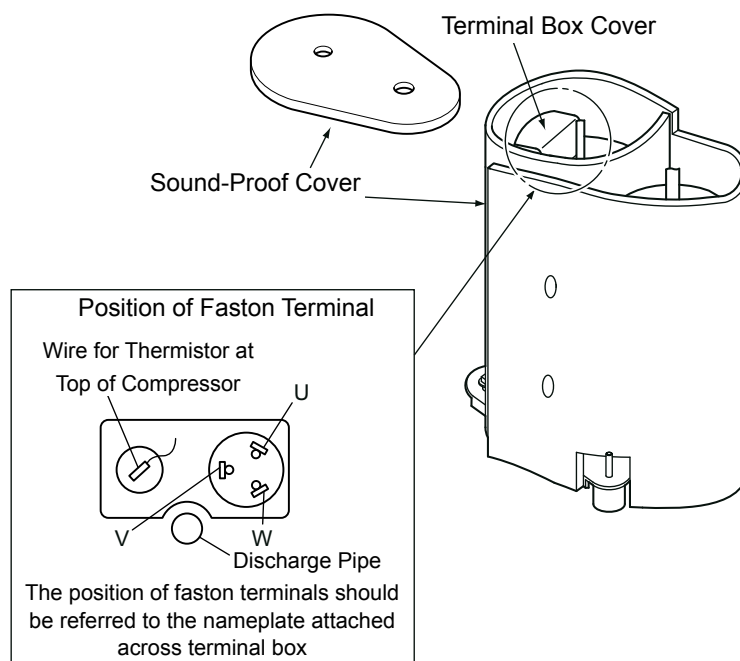

- 6 Remove the crankcase heater.
- 7 Remove the suction pipe and discharge pipe from the compressor. Remove the brazed part after cutting the pipes at "A" by a pipe cutter.

**NOTE**

Be sure to separate the blazing burner flame sufficiently from the wires and electrical components around the brazed part in order to avoid burning.

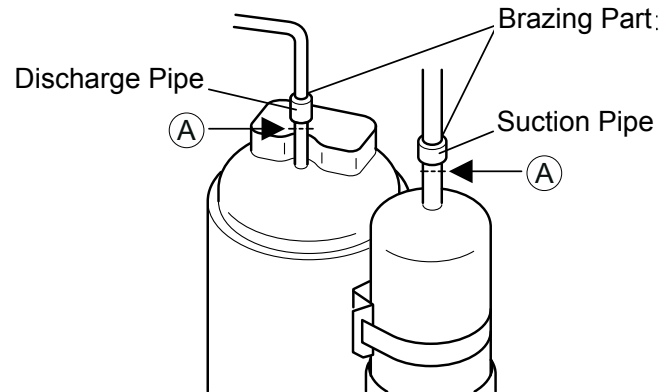

- 8 Remove 1 nut which fix the compressor and remove it by lifting up.

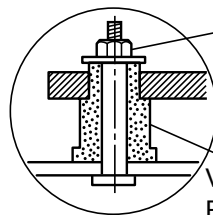
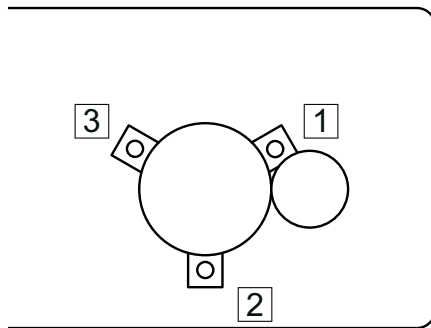

Nut
Vibration-proof Rubber

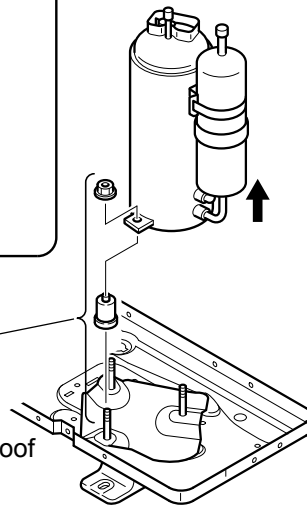

Compressor Position	1	2	3
Vibration-Proof Rubber	○	○	○
Nut	-	○	-

○ : with a nut
- : without a nut

- 9 When brazing the replaced compressor braze quickly cooling the pipes on the compressor side with wet cloth to avoid the filler metal entering into the compressor.

**NOTE**

PAY CLOSE ATTENTION not to let the filler metal enter into the compressor which may result in compressor damage.

- 10 Perform in the reverse procedure of removing after replacing the compressor.
 - a. Check if the Faston terminal has any abnormality. (Ensure the pull out force greater than 20 Nm) If the Faston terminal is identified faulty replace with a new one.
 - b. Ensure the fixture of the lead wires.
 - c. Attach the crankcase heater to the compressor without torsion and gap as shown in the figure below.

Detail of Spring for Crankcase Heater

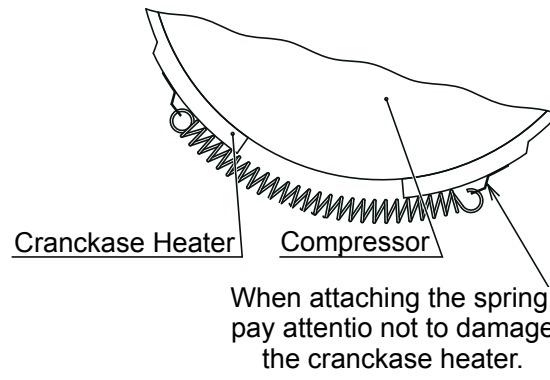
**NOTE**

- *To prevent contamination of the refrigerant by water or foreign materials, do not expose the refrigerant parts open to atmosphere for long periods. If necessary, seal pipe ends using caps or tape.*
- *Remove the cap for compressor right before replacing the compressor. When replacing the compressor, seal the tape at the suction and the discharge pipes to prevent foreign materials. Remove it when brazing pipes.*
- *Securely check terminal numbers and mark bands before disconnecting lead wires. When reassembling the lead wires, connect them to match surely the terminal numbers and the mark bands. If the lead wires are connected incorrectly to the terminal, the compressor will be damaged due to reverse rotation.*

◆ RAS-(5-6)H(V)NCE

- 1 Remove the service cover, upper cover, bottom service cover and rear cover following *Removing service cover*, *Removing upper cover*, and *Removing bottom service cover and rear cover*. When the outdoor unit is installed close to a wall remove the refrigerant piping and move the unit from the wall.
- 2 Remove the electrical box following *Removing electrical box*.
- 3 Collect the refrigerant from the check joint.
- 4 Remove the valve stay.

**NOTE**

Check Perform the recovery work at the check joint of piping. If not, the refrigerant remains inside.

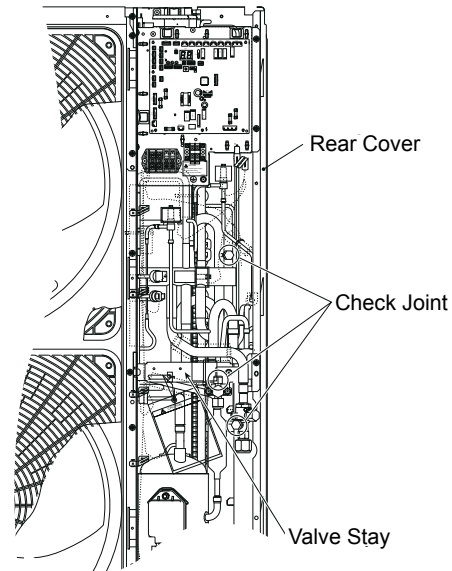

- 5 Open the soundproof cover wrapped around the compressor and remove the terminal box cover of the compressor body. Disconnect the compressor wires in the terminal box and disconnect the thermistor on top of the compressor. Remove the soundproof cover.

**NOTE**

Check the terminal codes and mark bands when disconnecting the wires. Connecting wires in wrong order at reassembling may result in compressor damage.

- 6 Remove the rubber cap and the thermistor attached on top of the compressor.
- 7 Remove the crankcase heater.

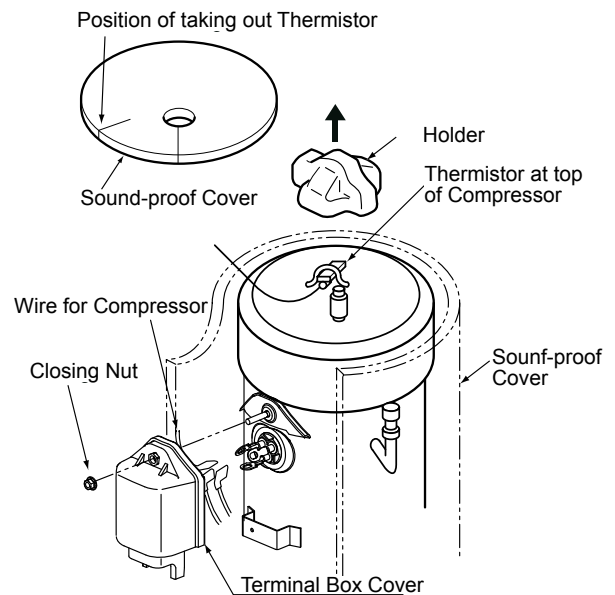
**NOTE**

- **Compressor piping must be connected by brazing. MAKE SURE that any flammable material is not around before heating with burner for the oil inside the piping may flame up.**
- **Do not expose the refrigerant cycle to the atmosphere for a long period to avoid moisture or dust into the cycle. Be sure to replace the compressor immediately after removing. Seal the suction and discharge pipes when the refrigerant cycle is left unattached for a long period.**
- **Remove the cap of new compressor right before the replacement. Before mounting the compressor seal the suction and discharge pipes with a tape to protect the compressor from dust. Remove the tape when blazing the pipe.**
- **For piping at reassembling ensure that the compressor terminal numbers and wiring mark band codes are matched. Incorrect wiring numbers may result in inverse rotation and damage of the compressor.**

- 8 Remove the suction pipe and discharge pipe from the compressor.

i NOTE

Be sure to separate the blazing burner flame sufficiently from the wires and electrical components around the brazed part in order to avoid burning.

- 9 Remove 2 nuts which fix the compressor and remove it by lifting it up with inclining forward.

i NOTE

To remove the compressor the liquid stop valve pipe should be moved (bent) to the right side hand. PAY CLOSE ATTENTION not to crush to break the pipe.

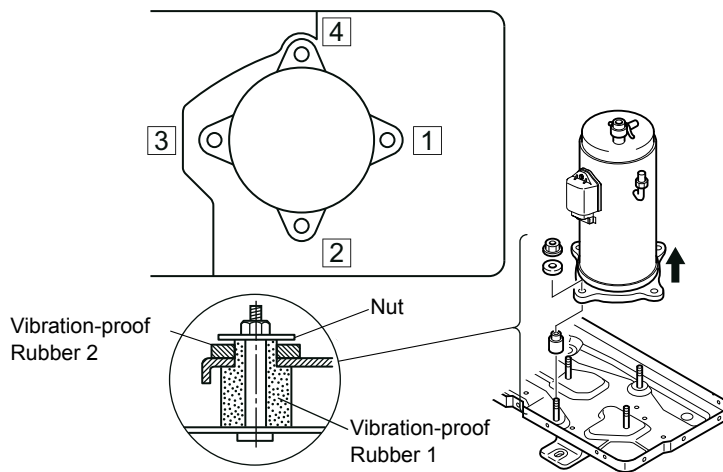

Fixation of the compressor to the bottom plate				
Compressor position	1	2	3	4
Vibration-proof rubber 1	x	x	x	x
Vibration-proof rubber 2	x	x	—	—
Nut	x	x	—	—

- 10 When brazing the replaced compressor quickly perform the brazing while the compressor side piping is cooled with wet cloth in order to avoid the brazing material from entering the compressor.

i NOTE

PAY CLOSE ATTENTION not to let the filler metal enter into the compressor which may result in compressor damage.

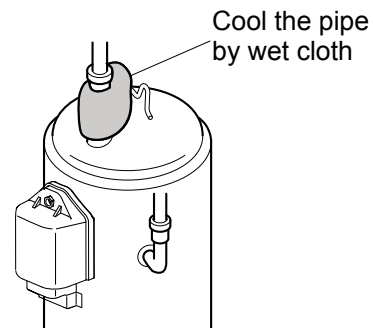

11 Perform in the reverse procedure of removing after replacing the compressor.

- a. Check if the Faston terminal has any abnormality. (Ensure the pull out force greater than 20 Nm). If the Faston terminal is identified faulty replace with a new one.
- b. Ensure the fixture of the lead wires.
- c. Surely fix the terminal box by tightening the closing nut (Tightening Torque: 3.0 Nm).
- d. Attach the top of sound-proof cover to cover surely the compressor.
- e. Wrap the sound-proof cover to cover the terminal box and the discharge pipe.
- f. Attach the crankcase heater without torsion and gap to the compressor as following figure.

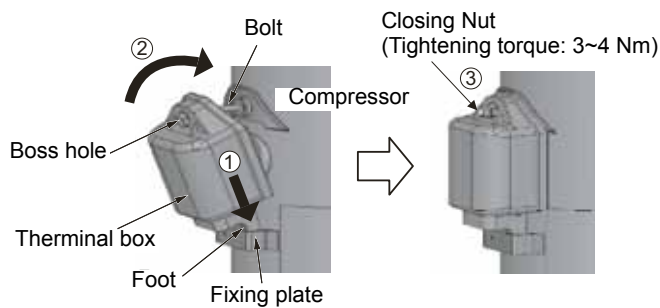
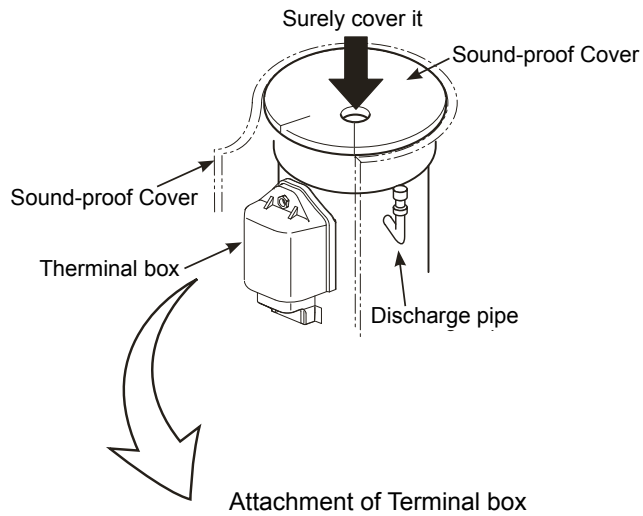

Detail of Spring for Cranckase Heater

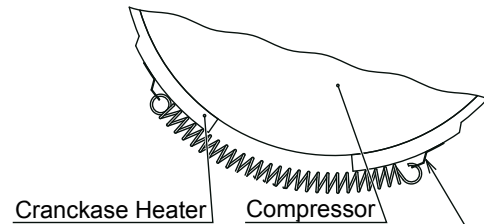

When attaching the spring, pay attentio not to damage the cranckase heater.

10.4.1.8 Removing the High pressure switch and Pressure switch for control

◆ RAS-4H(V)NCE

- 1 Remove the service cover and the bottom service cover following [Removing service cover](#), and [Removing bottom service cover and rear cover](#).
- 2 Collect the refrigerant from the check joint according to [Removing the compressor](#), in this chapter.
- 3 Remove the soundproof cover on the compressor.
- 4 Disconnect the Faston Terminals of High Pressure Switch and Pressure sensor for PD control.
- 5 Remove the high pressure switch and the pressure switch for control from the brazed part of discharge piping.

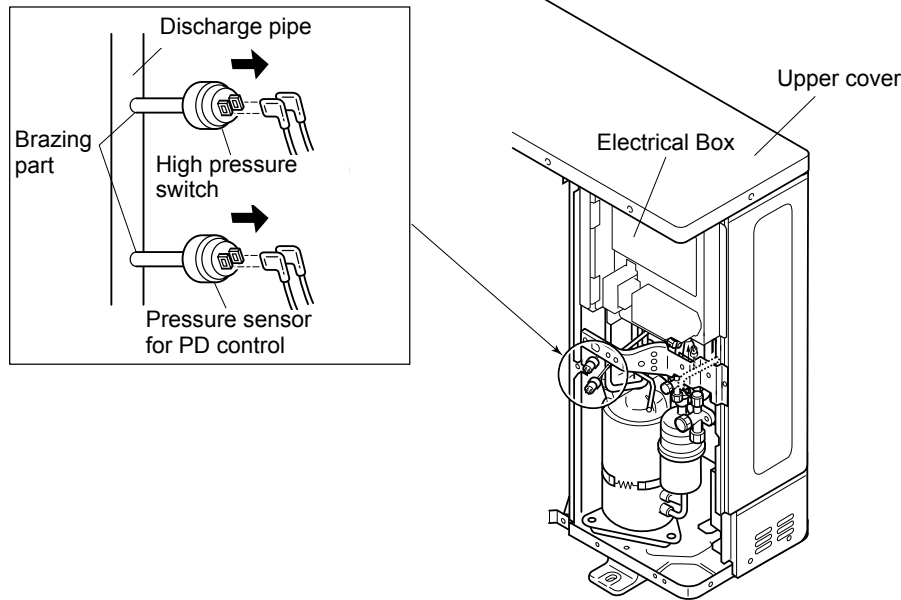

◆ RAS-(5-6)H(V)NCE

- 1 Remove the service cover, the bottom service cover and rear cover following [Removing service cover](#) and [Removing bottom service cover and rear cover](#).
- 2 Collect the refrigerant from the check joint according to [Removing the compressor](#), in this chapter.
- 3 Remove the soundproof cover on the compressor.
- 4 Disconnect the Faston Terminals of High Pressure Switch and Pressure sensor for PD control.
- 5 Remove the high pressure switch and the pressure switch for control from the brazed part of discharge piping.



NOTE

Beware the cover screws do not damage the wirings when performing the procedure in reverse way.

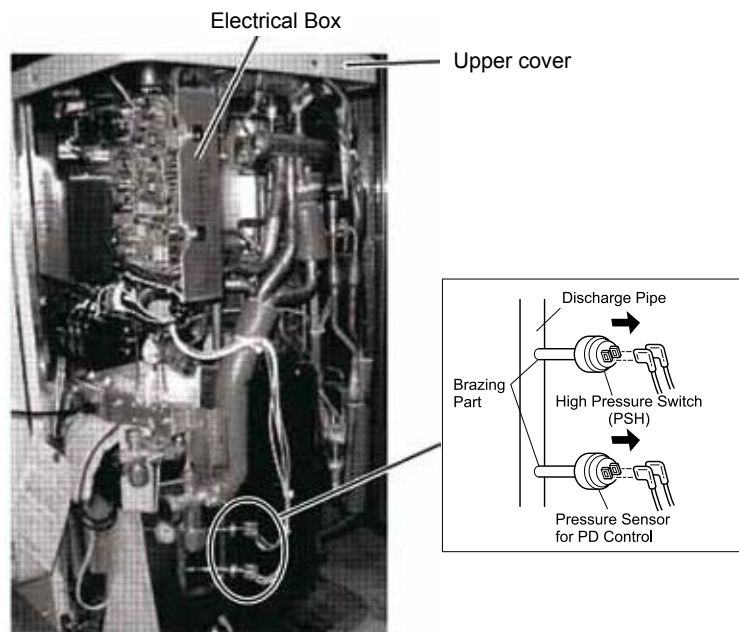

10.4.1.9 Opening electrical box (P plate)

- 1 Remove the service cover following [Removing service cover](#) in this chapter.
- 2 Unplug all the connectors of the electrical box.
- 3 Remove 5 screws which fix the electrical box and open the P plate turning counter clockwise approximately 90°.
 - Check that the LED201 (red) on the inverter PCB (PCB2) is OFF.

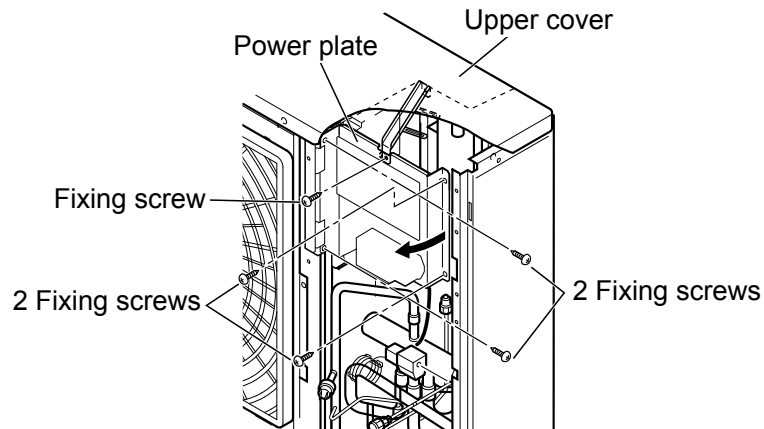

DANGER

- **DO NOT touch electrical components while the LED201 (Red) is ON to avoid electrical shock. Wait until the LED turns off.**

10.4.1.10 Removing Reversing valve coil

- 1 Remove the service cover, the bottom service cover, the rear cover and the upper cover following [Removing service cover](#), [Removing bottom service cover and rear cover](#) and [Removing upper cover](#).
- 2 Disconnect the PCN6 connector on the control PCB of the electrical box.
- 3 Remove 1 fixing screw to remove the reversing valve coil.

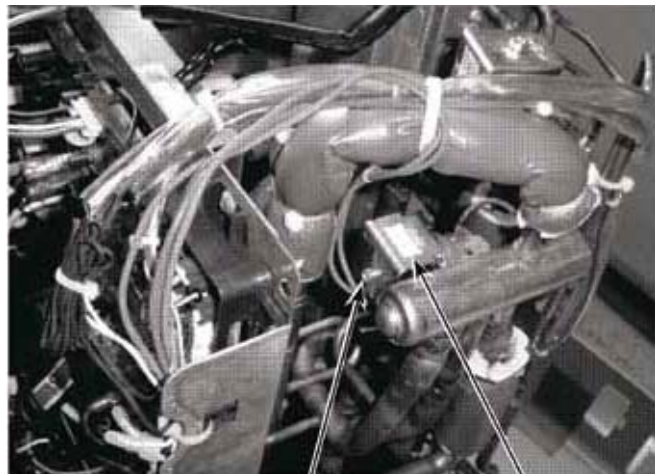

Fixing screw for
Reversing valve

Reversing valve

- 4 When reassembling, perform the procedure in the reverse way of removing.



NOTE

Fix the wires by plastic bands to the original position.

10.4.1.11 Removing electronic expansion valve coil

- 1 Remove the service cover, the bottom service cover, the rear cover and the upper cover following [Removing service cover](#), [Removing bottom service cover and rear cover](#) and [Removing upper cover](#).
- 2 Disconnect the CN5A connector on the control PCB of the electrical box.
- 3 Hold the coil of the expansion valve and pull out upward.
It is easier to remove the expansion valve coil if it is rotated while pulling it upward.
- 4 When reassembling after replacing the expansion valve coil, perform the procedure in the reverse way of removing. The expansion valve coil is equipped with a lock mechanism. After attaching the expansion valve coil, rotate it until the sound of locking is heard.



NOTE

Fix the wires by plastic bands to the original position.

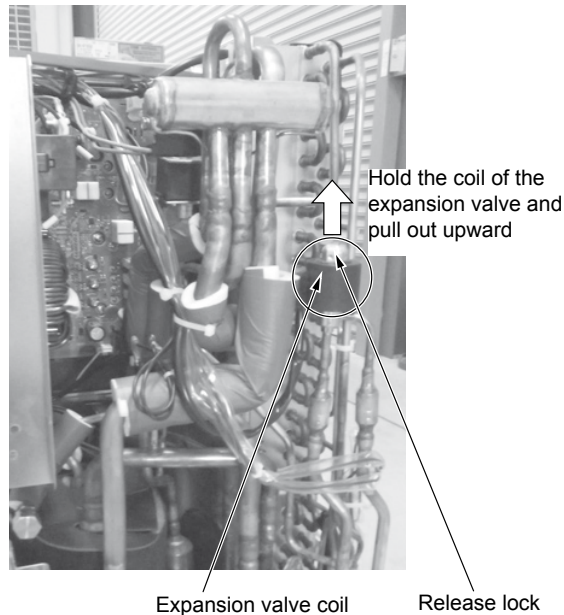

DANGER

DO NOT touch electrical components while the LED1 (Red) is ON to avoid electrical shock. Wait until the LED turns off.

10.4.1.12 Removing solenoid valve coil (SVA)

- 1 Remove the service cover and the upper cover following [Removing service cover](#) and [Removing upper cover](#).
- 2 Unplug the connector PCN7 (SVA) on O.U. PCB1.
- 3 Remove the fixing screw, and remove the solenoid valve coil (SVA) upward.
- 4 When reassembling after replacing the solenoid valve coil, perform the procedure in the reverse way of removing.



NOTE

Fix the wires by plastic bands to the original position.

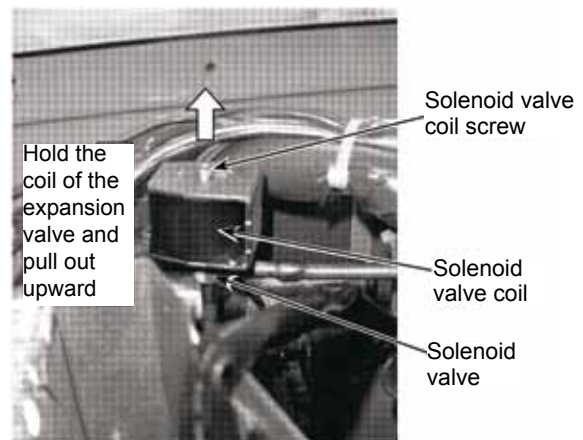

DANGER

DO NOT touch electrical components while the LED1 (Red) is ON to avoid electrical shock. Wait until the LED turns off.

10.4.1.13 Removing reversing valve

- 1 Remove the service cover, the bottom service cover, the rear cover and the upper cover following *Removing service cover*, *Removing bottom service cover and rear cover* and *Removing upper cover*.
- 2 Remove the reversing valve coil according to *Removing Reversing Valve Coil*.
- 3 Remove the electrical box according to *Removing Electrical Box*.
- 4 Remove the electronic expansion valve coil according to *Removing Electronic Expansion Valve Coil*.
- 5 Recover the refrigerant from check joints according to *Removing Compressor*.
- 6 Remove the high pressure switch wiring.
- 7 Remove the valve stay.
- 8 Remove the reversing valve assemblies from the fixed positions (4 brazing parts).
 - a. Remove the reversing valve and the stop valve with cooling the valve bodies by wet cloth.
 - b. Perform the brazing work with attention not to burn the electrical wirings and the piping insulations.
- 9 Remove reversing valve from the assemblies. (4 brazing parts) At this time, perform the brazing work with cooling the reversing valve body by wet cloth.
- 10 When reassembling after replacing the reversing valves, perform in the reverse procedure of removing.
 - a. Run the lead wires to be located to the original position, and fix them by the plastic band.
 - b. Attach the crankcase heater according to *Removing Compressor*.

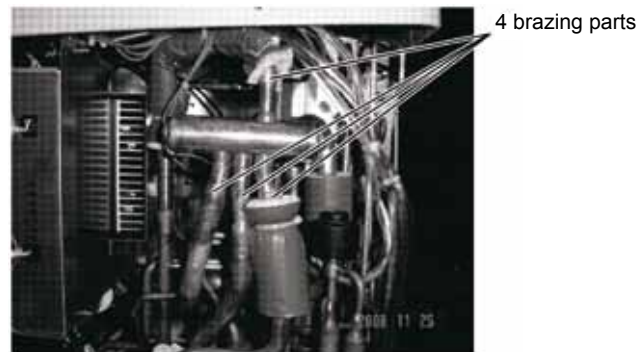
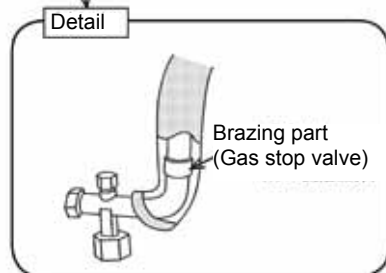
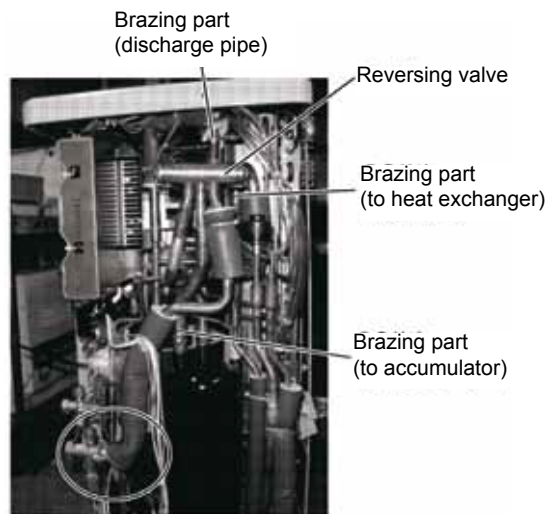

10.4.1.14 Removing Electronic expansion valve and Solenoid valve

- 1 Remove the service cover, the bottom service cover, the rear cover and the upper cover following *Removing service cover*, *Removing bottom service cover and rear cover* and *Removing upper cover*.
- 2 Recover the refrigerant from check joints according to *Removing Compressor*.
- 3 Remove the coils according to *Removing Electronic Expansion Valve Coil* and *Removing Solenoid Valve Coil*.
- 4 Remove the brazed parts as shown in the figures.
 - Electronic Expansion Valve (EVO) Brazed Parts: 2
 - Solenoid Valve (SVA) Brazed Parts: 2
 - a. Remove the electronic expansion valve and the solenoid valve with cooling the valve bodies by wet cloth.
 - b. Perform the brazing work with attention not to burn the electrical wirings and the piping insulations.
- 5 When reassembling after replacing the valves, perform in the reverse procedure of removing.

**NOTE**

Run the lead wires to be located to the original position, and fix them by the plastic band

10.4.1.15 Removing electrical components◆ **Removing control PCB (PCB1)**

- 1 Remove the service cover following *Removing service cover*.
- 2 Remove all the wiring connected to the control PCB.

**DANGER**

DO NOT touch electrical components while the LED1 (Red) is ON to avoid electrical shock. Wait until the LED turns off.

- 3 Remove the 6 holders. Clamp the middle part of the holders with long-nose pliers and remove it toward front side.

**DANGER**

DO NOT touch the electrical components on the PCB. Pay attention not to bend or apply much force onto PCB in order to avoid PCB failure.

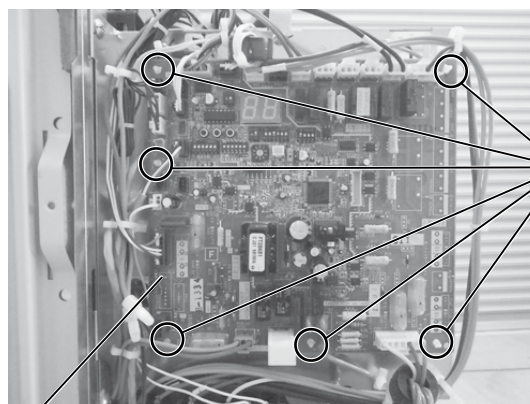

Holder

Printed Circuit Board (PCB1)

◆ Removing Inverter module

- 1 Remove the service cover following *Removing service cover* in this chapter.
- 2 Open the P plate turning counter clockwise approximately 90° following *Opening electrical box (P plate)*.
 - Check that the LED201 (red) on Inverter is OFF when the P plate is opened.



DANGER

DO NOT touch electrical components while the LED201 (Red) is ON to avoid electrical shock. Wait until the LED turns off.

- 3 Remove all the wiring connected on the Inverter.
- 4 Remove 4 screws which fix the Inverter.
Hold the wires placed at the bottom side.
- 5 Pull the Inverter toward right side from the front of the product. (Remove along with the plastic case and the radiation fin).

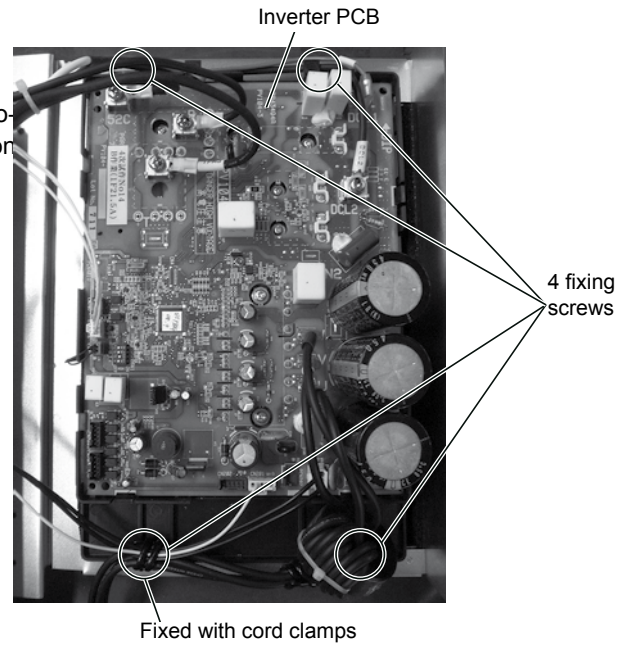

10.4.1.16 Removing other electrical components

- 1 Remove the service cover following [Removing service cover](#) in this chapter.
- 2 Open the P plate turning counter clockwise approximately 90° following [Opening electrical box \(P plate\)](#).
 - Check that the LED201 (red) on Inverter is OFF when the P plate is opened.



DANGER

DO NOT touch electrical components while the LED201 (Red) is ON to avoid electrical shock. Wait until the LED turns off.

CMC

- 1 Remove all the wiring connected to CMC.
- 2 Remove 2 screws fixing the CMC.

Reactor

- 1 Remove 4 screws fixing the reactor.

Noise filter

- 1 Remove all the wiring connected to the noise filter.
- 2 Hold the upper part of the 6 holders with the long nose pliers and remove the noise filter.

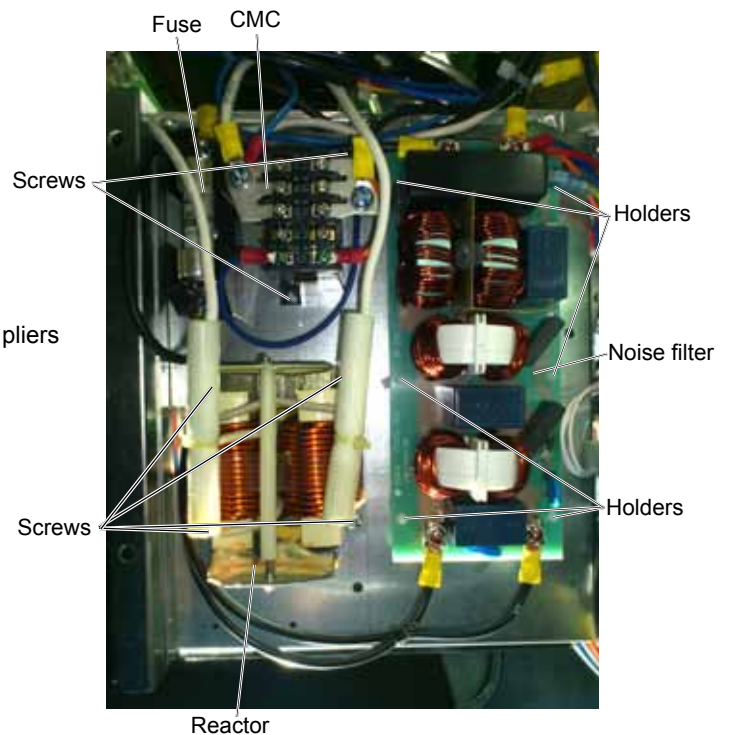
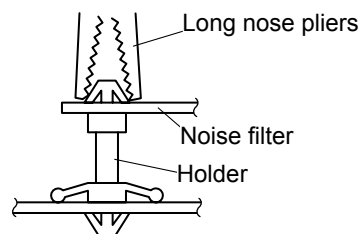

NOTE

- **To connect wiring at reassembling, ensure that the terminal numbers and wiring mark band codes are matched. If connections are wrong, there is the possibility of wrong operation and to cause damage to electrical parts.**
- **When attaching the PCB, or when attaching the parts attached to the PCB, pay attention not to clamp any wiring between plates or electrical components.**

10.4.2 Outdoor Units RAS-(8-10)HNCE

10.4.2.1 Removing service cover



NOTE

- Follow the procedure below to remove main parts and components. For mounting follow the reverse procedure of removal.
 - Do not expose the refrigerant cycle to the atmosphere for a long period to avoid moisture or dust entering into the cycle. Be sure to replace parts immediately after removing. Seal the refrigerant cycle when left unattached for a long period.
- 1 Remove the 4 fixing screws, slide the service cover downward and remove it.
 - Pay attention not to fall off the service cover.

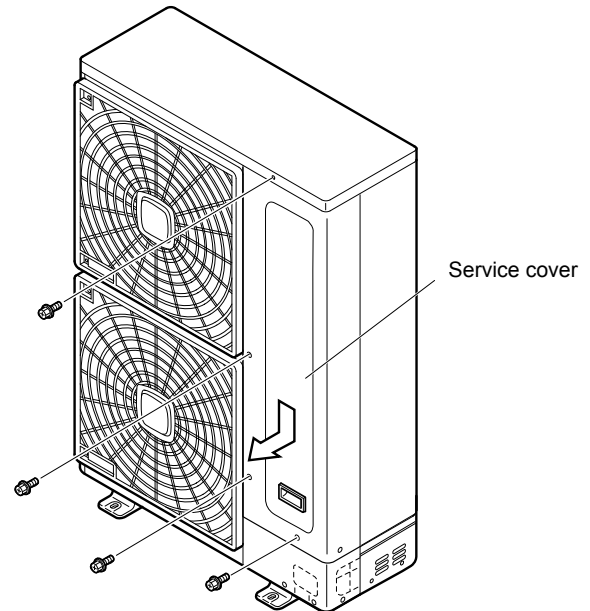

10.4.2.2 Removing air outlet grille

- 1 Remove the 8 fixing screws of the shroud.

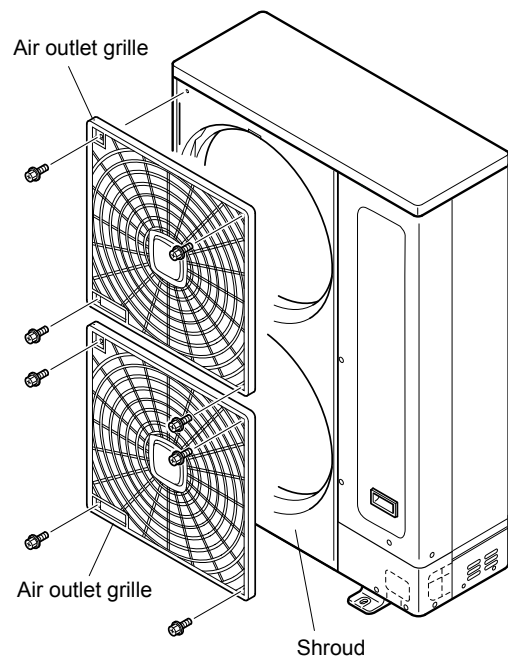

10.4.2.3 Removing upper cover

- 1 Remove 11 screws fixing the upper cover and remove the upper cover upward.

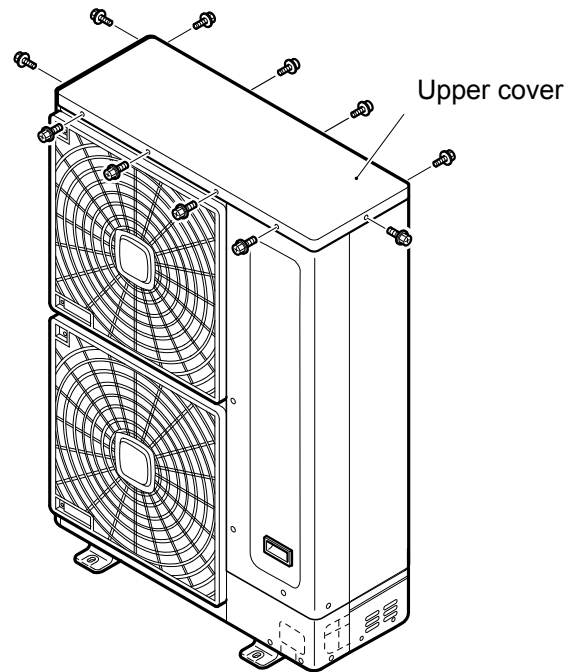
**10.4.2.4 Removing the bottom service cover and rear cover**

- 1 Remove 5 screws fixing the lower part of service cover and remove the lower part of service cover by pulling towards front side.
- 2 Remove the upper cover according to the item [Removing upper cover](#).
- 3 Remove 10 screws fixing panel and remove the rear panel by pulling in the arrow direction.

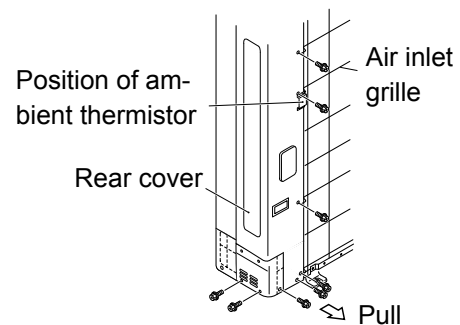
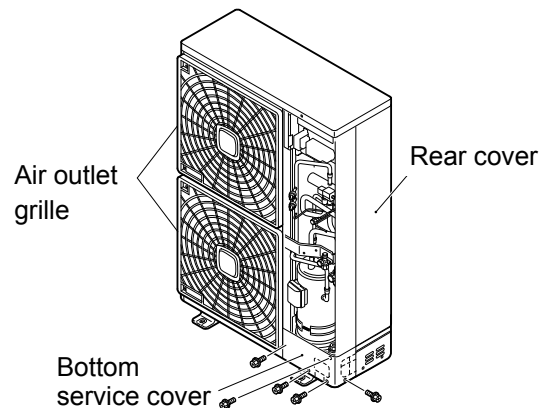

DO NOT touch electrical components while the LED1 (Red) is ON to avoid electrical shock. Wait until the LED turns off.

10.4.2.5 Removing outdoor fan motor

- 1 Remove the service cover following [Removing service cover](#).
- 2 Remove the outlet grille following [Remove outlet grille](#).
- 3 Remove the upper cover following [Removing upper cover](#).
- 4 To remove the propeller fan remove the cap nut and washer which fix the propeller fan onto the motor shaft. (Use a puller when the propeller fan and motor shaft are fixed too tightly).

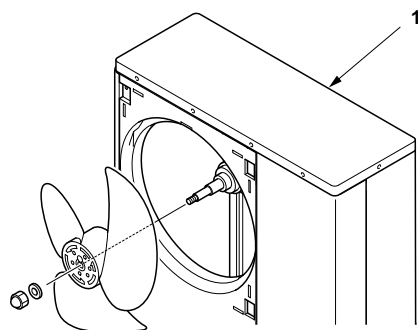

1. Upper cover.

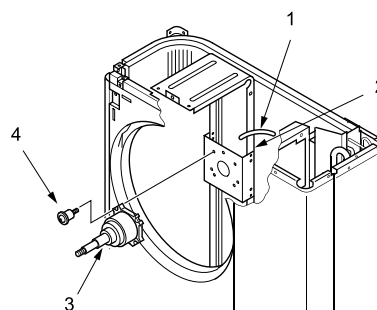

1. Fan motor lead wire.
2. Motor clamp.
3. Motor.
4. Screw with spacer.

- 5 Remove the fan motor connector from PCB in the electrical box.
Cut the plastic tie with nippers which fixes the fan motor lead wire onto the motor clamp.
Remove 4 screws which fix the motor.

Model		RAS-(8-10)HNCE
Fan Motor Comp. N°	DC Fan Motor	Inverter PCB CN406 (Red)
	AC Fan Motor	inverter PCB CN405 (White)
Screws for motor fixing.	DC Fan Motor	4 x M6 screw (with spacer)
	AC Fan Motor	4x M6 screws

<ol style="list-style-type: none"> 1. Motor clamp. 2. Fan motor lead wire. 3. Plastic tie. 4. DC Fan Motor. 5. AC Fan Motor. 	
---	--



NOTE

- 1 **To mount the motor be sure to place the lead wire outlet downward.**
(Adjust the propeller fan and shroud not to contact with each other).
- 2 **Fix the motor lead wire onto the motor clamp using a plastic tie as shown in the table on the previous page to avoid obstructing the propeller fan.**
- 3 **Mounting propeller fan:**
Insert the skidding protection part of the fan boss matching with the motor shaft notch; tighten the nut after the shaft screw fully comes out. (Tightening Torque 20 Nm)
- 4 **Connect the motor lead wire to PCB1 of the electrical box.**
(Be sure to match colors of the PCB connectors and motor lead wire connectors).
- 5 **Be sure to attach the outlet grill onto the shroud after replacing the fan motor.**

10.4.2.6 Removing electrical box

- 1 Remove the service cover following [Removing service cover](#).
- 2 Remove the upper cover following [Removing upper cover](#).
- 3 Remove 6 screws which fix the electrical box.
- 4 Pull up and remove the electrical box.

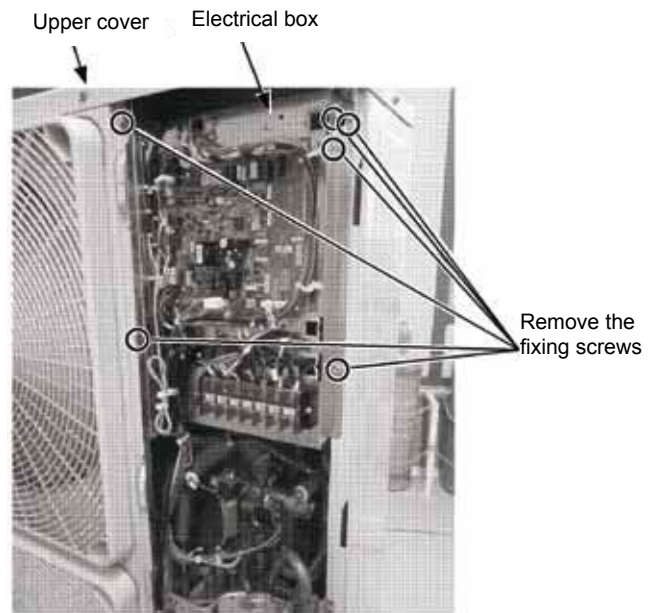

NOTE

The following wiring must be removed to dismantle the electrical box.

1. Remove the reversing valve coil from the reversing valve. : [Removing reversing valve coil](#).
2. Remove the expansion valve coil from the expansion valve. : [Removing electronic expansion valve coil](#).
3. Remove the solenoid valve coil from the solenoid valve. : [Removing solenoid valve coil](#).
4. Remove the Faston terminals of high pressure switch and the pressure switch for control from the switch body : [Removing the high pressure switch and pressure switch for control](#).
5. Remove all connectors on the control PCB.
6. Remove the compressor wires in the terminal box of the compressor.
7. To remount the electrical box attach the electrical box fitting with the partition plate.
(Insert the radiation fin into the U-notch on the partition plate and place the fin on the fan box side. Then attach the electrical box hooking onto the partition plate).



Front side

Original position

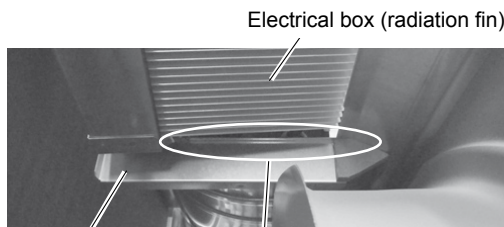

Front side

Partition plate

Place the electrical box (radiation fin) in front of the partition plate.
(Refer to the original position)

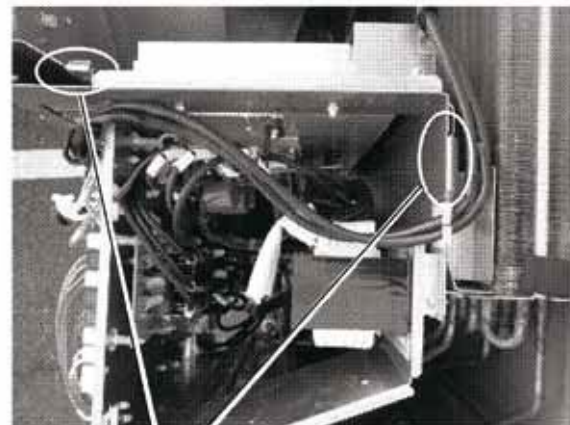

Place the electrical box to hook the parts onto the partition plate.

10.4.2.7 Removing the compressor

- 1 Remove the service cover and the bottom service cover following [Removing service cover](#), and [Removing bottom service cover and rear cover](#).

When the outdoor unit is installed close to a wall remove the refrigerant piping and move the unit from the wall.

- 2 Collect the refrigerant from the check joint.



NOTE

Check Perform the recovery work at the check joint of piping. If not, the refrigerant remains inside.

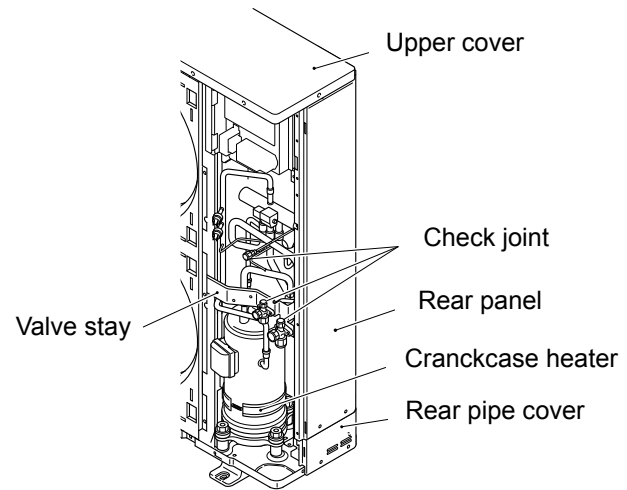

- 3 Open the soundproof cover wrapped around the compressor and remove the terminal box cover of the compressor body. Disconnect the compressor wires in the terminal box and disconnect the thermistor on top of the compressor. Remove the soundproof cover.



NOTE

Check the terminal codes and mark bands when disconnecting the wires. Connecting wires in wrong order at reassembling may result in compressor damage.

- 4 Remove the rubber cap and the thermistor attached on top of the compressor.
- 5 Remove the crankcase heater.

1. Sound-proof cover.

2. Oil heater.

3. Cut part.

A. Direction to remove the cover.

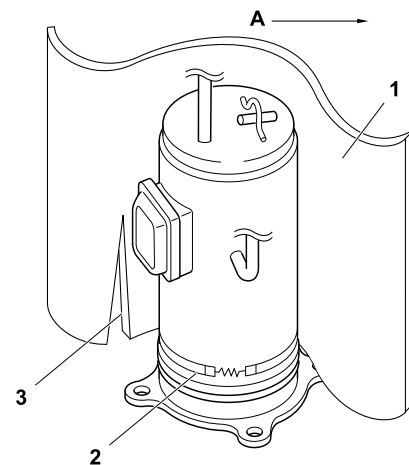

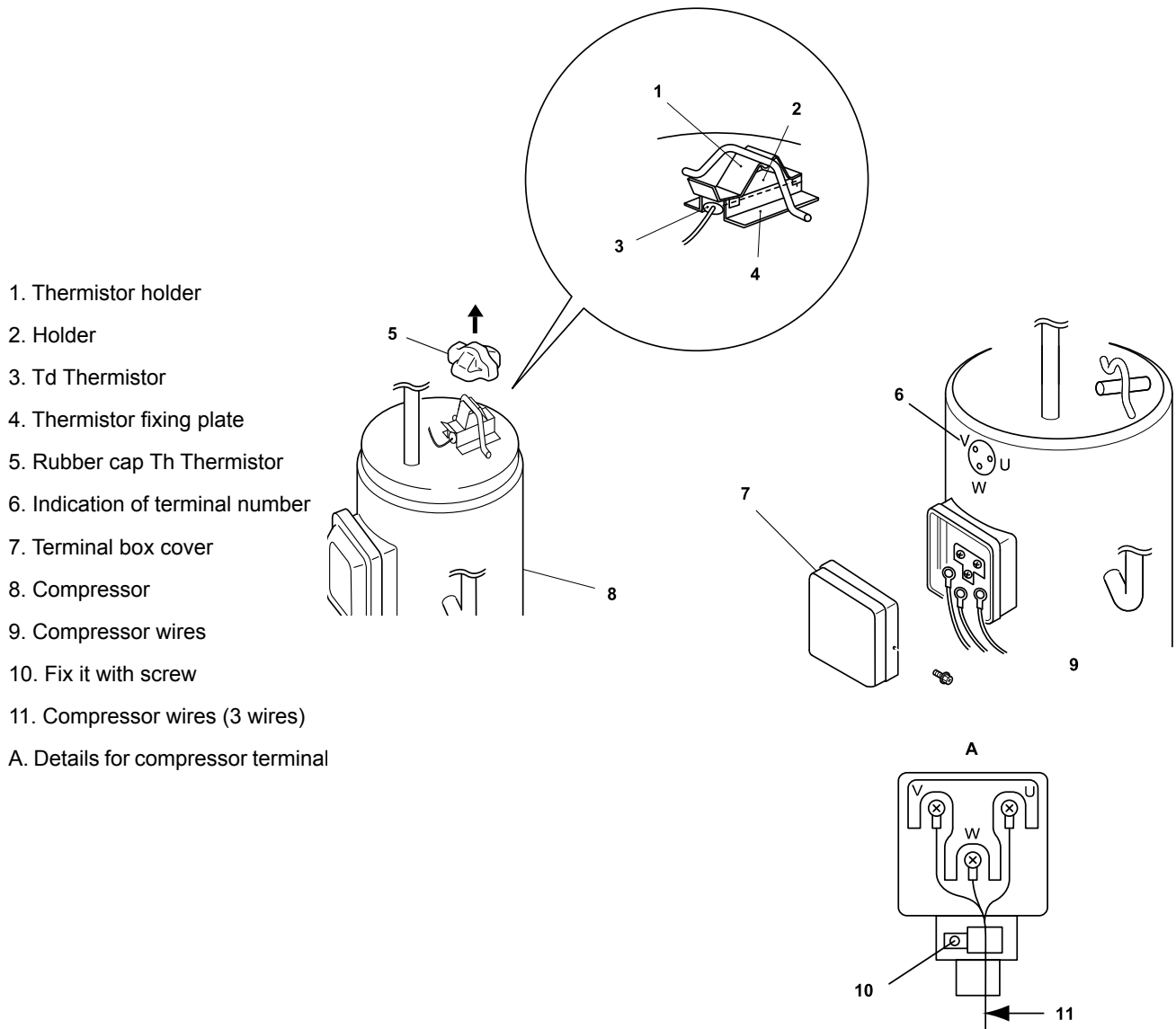

1. Thermistor holder
2. Holder
3. Td Thermistor
4. Thermistor fixing plate
5. Rubber cap Th Thermistor
6. Indication of terminal number
7. Terminal box cover
8. Compressor
9. Compressor wires
10. Fix it with screw
11. Compressor wires (3 wires)
- A. Details for compressor terminal

i NOTE

- **Compressor piping must be connected by brazing. MAKE SURE that any flammable material is not around before heating with burner for the oil inside the piping may flame up.**
 - **Do not expose the refrigerant cycle to the atmosphere for a long period to avoid moisture or dust into the cycle. Be sure to replace the compressor immediately after removing. Seal the suction and discharge pipes when the refrigerant cycle is left unattached for a long period.**
 - **Remove the cap of new compressor right before the replacement. Before mounting the compressor seal the suction and discharge pipes with a tape to protect the compressor from dust. Remove the tape when blazing the pipe.**
 - **For piping at reassembling ensure that the compressor terminal numbers and wiring mark band codes are matched. Incorrect wiring numbers may result in inverse rotation and damage of the compressor.**
- 6 Remove the suction pipe and discharge pipe from the compressor.

i NOTE

Be sure to separate the blazing burner flame sufficiently from the wires and electrical components around the brazed part in order to avoid burning.

- 7 Remove 2 nuts which fix the compressor and remove it by lifting it up with inclining forward.

i NOTE

To remove the compressor the liquid stop valve pipe should be moved (bent) to the right side hand. **PAY CLOSE ATTENTION not to crush to break the pipe.**

- 8 When brazing the replaced compressor quickly perform the brazing while the compressor side piping is cooled with wet cloth in order to avoid the brazing material from entering the compressor.

i NOTE

PAY CLOSE ATTENTION not to let the filler metal enter into the compressor which may result in compressor damage.

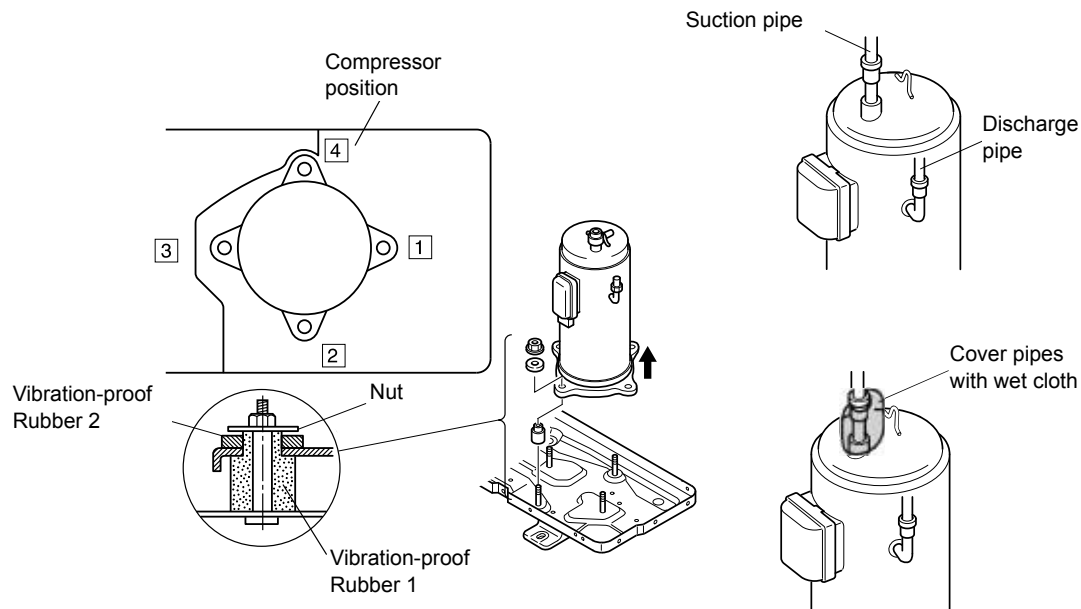

Fixation of the compressor to the bottom plate				
Compressor position	1	2	3	4
Vibration-proof rubber 1	x	x	x	x
Vibration-proof rubber 2	x	x	—	—
Nut	x	x	—	—

- 9 Reassemble the parts in the reverse order of removing procedures.
- Tighten the screws (U V and W) for compressor wires with 2.5 Nm.
 - Fix the wires firmly.
 - Attach the crankcase heater without torsion and gap to the compressor as following figure.

Detail of Spring for Crankcase Heater

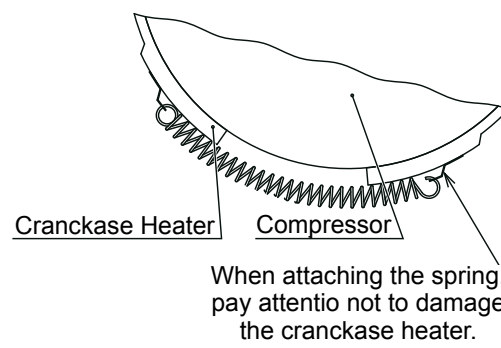

10.4.2.8 Removing High pressure switch and pressure switch for control

- 1 Remove the service cover following [Removing service cover](#) in this chapter.
- 2 Collect the refrigerant from the check joint according to [Removing the compressor](#), in this chapter.
- 3 Disconnect the Faston Terminals of High Pressure Switch and Pressure sensor for PD control.
- 4 Remove the high pressure switch and the pressure switch for control from the brazed part of discharge piping.

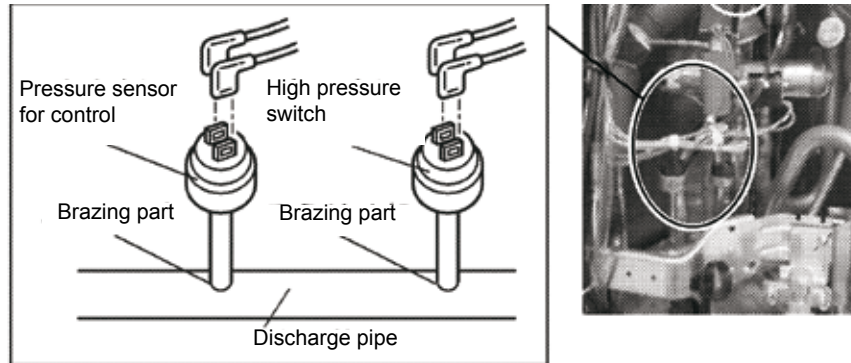

10.4.2.9 Opening electrical box (P-Mounting Plate)

- 1 Remove the service cover following [Removing service cover](#) in this chapter.
- 2 Remove 6 screws which fix the electrical box and open the P plate turning counter clockwise approximately 90°.
 - Check that the LED201 (red) on the inverter PCB (PCB2) is OFF when opening P-mounting plate.

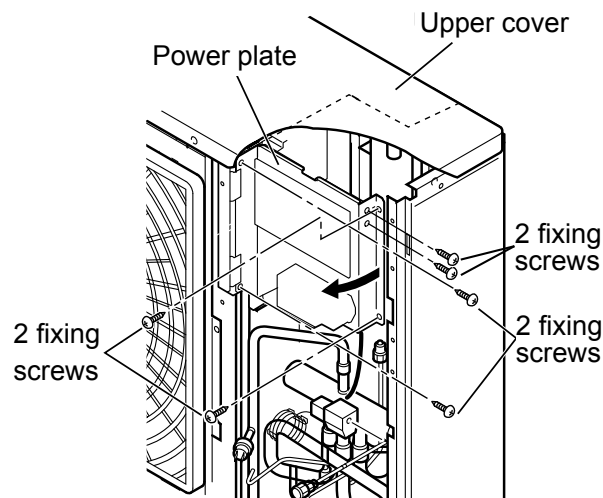

DO NOT touch electrical components while the LED201 (Red) or LED1 (Red) are ON to avoid electrical shock. Wait until the LEDs turn off.

10.4.2.10 Removing reversing valve coil

- 1 Remove the service cover following *Removing service cover* in this chapter.

**DANGER**

DO NOT touch electrical components while the LED1 (Red) is ON to avoid electrical shock. Wait until the LED turns off.

- 2 Remove the connector (PCN6) on the control PCB (PCB1) of the electrical box.
- 3 Remove the reversing valve coil by removing 1 screw fixing the coil.

1. Upper cover.
2. Power Plate.
3. PCN6.
4. Fixing screw for reversing valve coil.
5. Reversing valve coil.
6. Compressor.
7. Reversing valve.
8. Electrical Box.

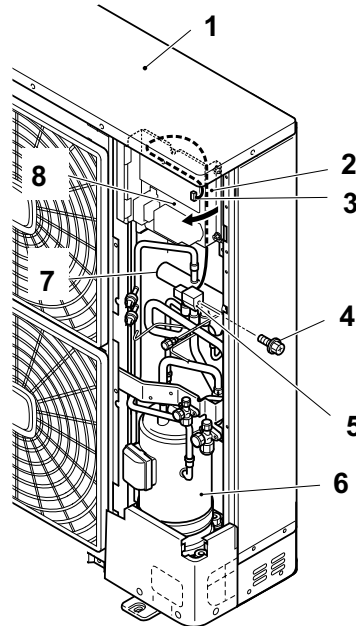

- 4 When reassembling, perform the procedure in the reverse way of removing.

**NOTE**

Fix the wires by plastic bands to the original position.

10.4.2.11 Removing electronic expansion valve coil

- 1 Remove the service cover, the bottom service cover and the rear cover following [Removing service cover](#) and [Removing bottom service cover and rear cover](#).
- 2 Disconnect the CN5A connector on the control PCB1 of the electrical box.
- 3 Hold the coil of the expansion valve and pull out upward.
It is easier to remove the expansion valve coil if it is rotated while pulling it upward.
- 4 When reassembling after replacing the expansion valve coil, perform the procedure in the reverse way of removing. The expansion valve coil is equipped with a lock mechanism. After attaching the expansion valve coil, rotate it until the sound of locking is heard.



NOTE

Fix the wires by plastic bands to the original position.

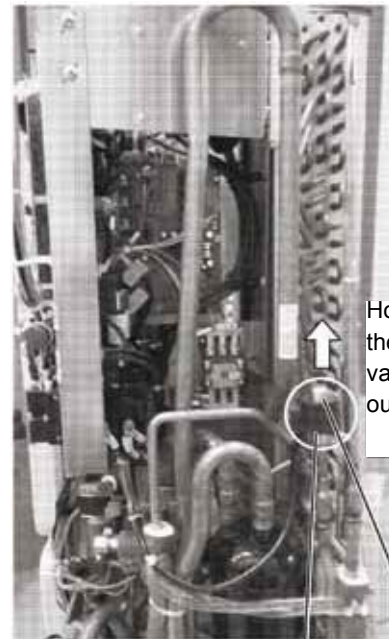

Hold the coil of the expansion valve and pull out upward

Expansion valve coil Release lock



DANGER

DO NOT touch electrical components while the LED201 (Red) or LED1 (Red) are ON to avoid electrical shock. Wait until the LEDs turn off.

10.4.2.12 Removing solenoid valve coil (SVA)

- 1 Remove the service cover following [Removing service cover](#).
- 2 Open the P-mounting plate. Check to ensure the LED201 (Red) of the inverter PCB (PCB2) is OFF.
- 3 Unplug the connector PCN7 (SVA) on O.U. PCB1.
- 4 Remove the fixing screw, and remove the solenoid valve coil (SVA) upward.
- 5 When reassembling after replacing the solenoid valve coil, perform the procedure in the reverse way of removing.



NOTE

Fix the wires by plastic bands to the original position.

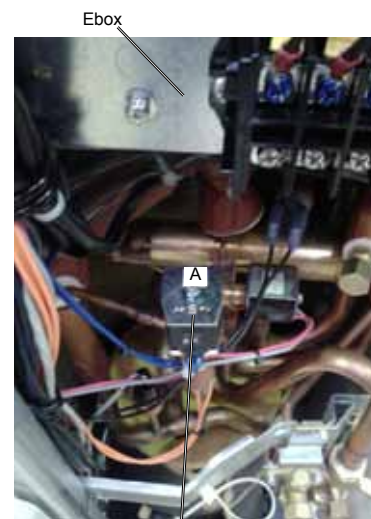

Solenoid valve coil (SVA)



DANGER

DO NOT touch electrical components while the LED201 (Red) or LED1 (Red) are ON to avoid electrical shock. Wait until the LEDs turn off.

10.4.2.13 Removing reversing valve

- 1 Remove the service cover, the bottom service cover and the rear cover following *Removing service cover* and *Removing bottom service cover and rear cover*.
- 2 Remove the reversing valve coil according to *Removing Reversing Valve Coil*.
- 3 Recover the refrigerant from check joints according to *Removing Compressor*.
- 4 Remove the reversing valve assemblies from the fixed positions (4 brazing parts).
 - a. Remove the reversing valve and the stop valve with cooling the valve bodies by wet cloth.
 - b. Perform the brazing work with attention not to burn the electrical wirings and the piping insulations.
- 5 Remove reversing valve from the assemblies. (4 brazing parts) At this time, perform the brazing work with cooling the reversing valve body by wet cloth.
- 6 When reassembling after replacing the reversing valves, perform in the reverse procedure of removing.
 - a. Run the lead wires to be located to the original position, and fix them by the plastic band.
 - b. Attach the crankcase heater according to *Removing Compressor*.
- 7 Reassemble the parts in the reverse order of removing procedures.

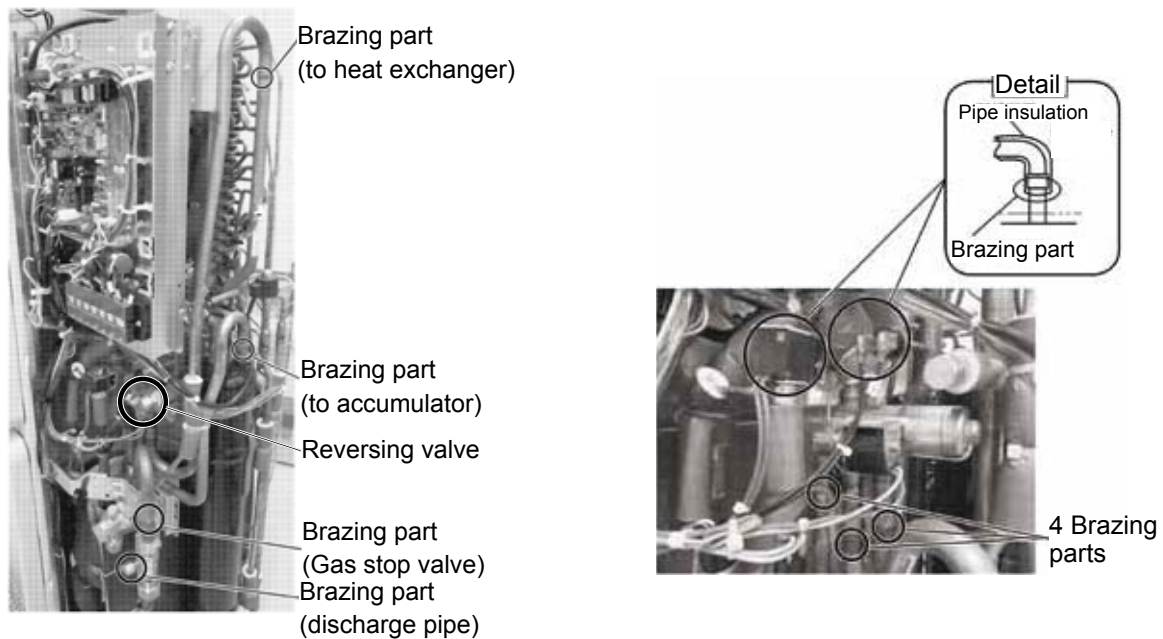

10.4.2.14 Removing Electronic expansion Valve and Solenoid Valve

- 1 Remove the service cover, the bottom service cover and the rear cover following *Removing service cover* and *Removing bottom service cover and rear cover*.
- 2 Recover the refrigerant from check joints according to *Removing Compressor*.
- 3 Remove the coils according to *Removing Electronic Expansion Valve Coil* and *Removing Solenoid Valve Coil*.

- 4 Remove the brazed parts as shown in the figures.
 - Electronic Expansion Valve (EVO) Brazed Parts: 2
 - Solenoid Valve (SVA) Brazed Parts: 2
 - a. Remove the electronic expansion valve and the solenoid valve with cooling the valve bodies by wet cloth.
 - b. Perform the brazing work with attention not to burn the electrical wirings and the piping insulations.

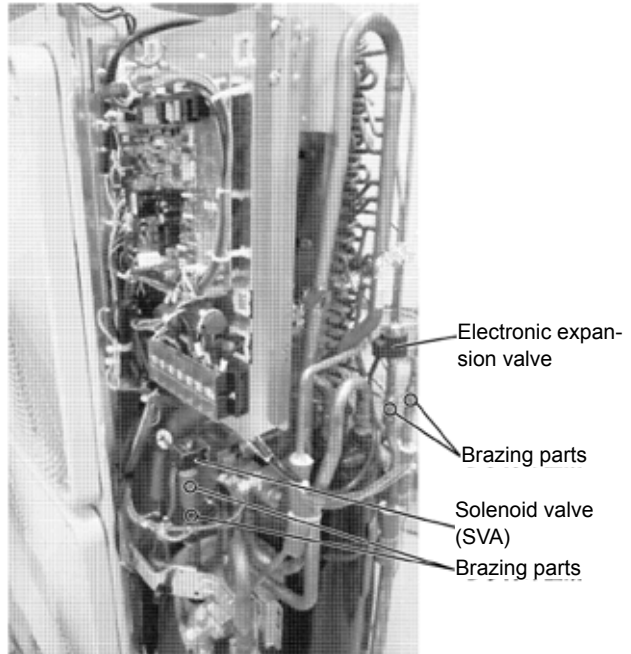

- 5 When reassembling after replacing the valves, perform in the reverse procedure of removing.

**NOTE**

Run the lead wires to be located to the original position, and fix them by the plastic band

10.4.2.15 Removing electrical components

◆ Removing control PCB (PCB1) and relay PCB (PCB3)

- 1 Remove the service cover following [Removing service cover](#).
- 2 Remove all the wiring connected to the control PCB and the relay PCB.



DANGER

DO NOT touch electrical components while the LED1 (Red) is ON to avoid electrical shock. Wait until the LED turns off.

- 3 Remove the 6 holders for each PCB. Clamp the middle part of the holders with long-nose pliers and remove it toward front side.



DANGER

DO NOT touch the electrical components on the PCB. Pay attention not to bend or apply much force onto PCB in order to avoid PCB failure.

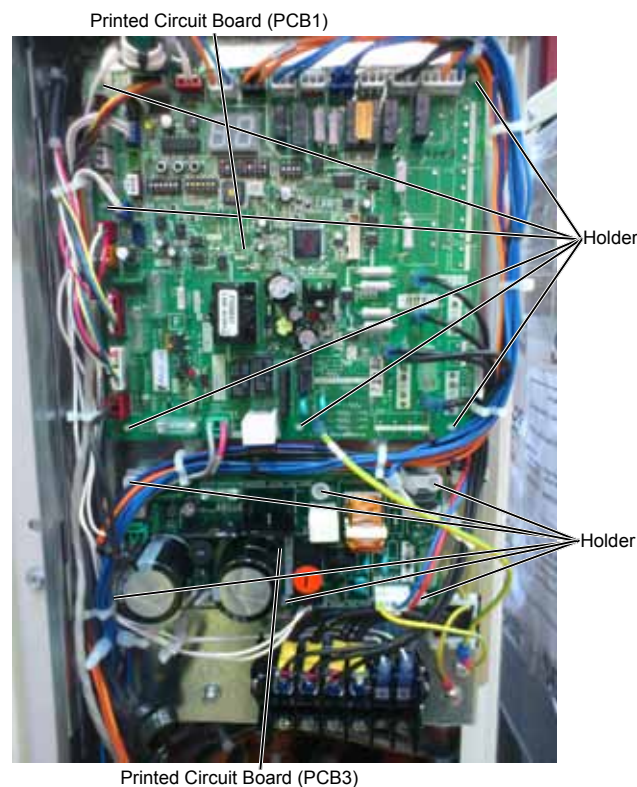
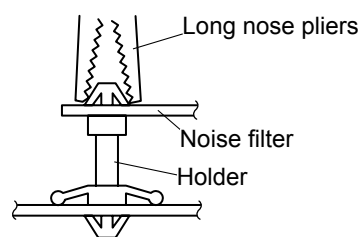

◆ Removing Inverter module

- 1 Remove the service cover following [Removing service cover](#).
- 2 Open the P plate turning counter clockwise approximately 90° following [Opening electrical box \(P plate\)](#).
 - Check that the LED201 (red) on Inverter is OFF when the P plate is opened.



DANGER

DO NOT touch electrical components while the LED201 (Red) or LED1 (Red) are ON to avoid electrical shock. Wait until the LEDs turn off.

- 3 Remove 4 screws M3, remove the bushes and remove the spacers fixing the inverter.



NOTE

When mounting again be sure to place the bushes and spacers.

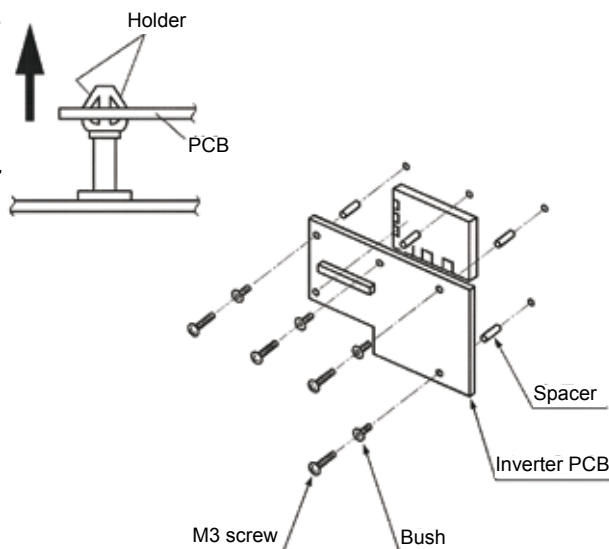

Removing Diode Module (DM)

- 1 Disconnect the wirings of terminal + - U V W on the diode module.
- 2 Remove 2 M5 fixing screws on the diode module.
- 3 Remove the diode module from the electrical box.

- 1: 5 Screws (M5)
- 2: Fixing screw (M5)



Removing Transistor Module (IPM)

- 1 Disconnect all the wirings connected to the transistor module.
- 2 Remove the connectors CN2, CN3, CN206, PCN301 and PCN302 from the transistor module.
- 3 Disconnect the wirings of P N U V W on the transistor module.
- 4 Remove 4 M4 fixing screws on the transistor module.
- 5 Remove the transistor module from the electrical box.

1. Screws for transistor module (M4)
2. Screw (M5)
3. PCN301
4. PCN302
5. Screws for PCB (M3)
6. CN3
7. Inverter PCB
8. CN206
9. CN2
10. LED201

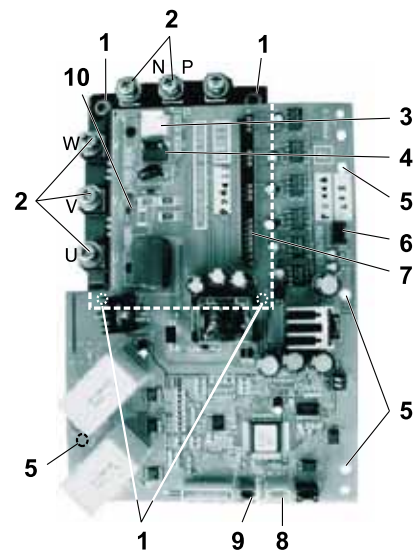

- 6 Reassemble the parts in the reverse order of removing order.

NOTE

- To connect wiring at reassembling, ensure that the terminal numbers and wiring mark band codes are matched. If connections are wrong, there is the possibility of wrong operation and to cause damage to electrical parts.
- When attaching the PCB, or when attaching the parts attached to the PCB, pay attention not to clamp any wiring between plates or electrical components.

10.4.2.16 Removing other electrical components

- 1 Remove the service cover following [Removing service cover](#) in this chapter.
- 2 Open the P plate turning counter clockwise approximately 90° following [Opening electrical box \(P plate\)](#).
 - Check that the LED201 (red) on Inverter is OFF when the P plate is opened.



DANGER

DO NOT touch electrical components while the LED201 (Red) is ON to avoid electrical shock. Wait until the LED turns off.

Capacitors

- 1 Remove all the wiring connected to the capacitors.



NOTE

The wires have polar characters. Identify the wire mark band and the indication on the capacitor when connecting wires.

- 2 Remove 3 screws fixing each capacitor.

CMC

- 1 Remove all the wiring connected to CMC.
- 2 Remove 2 screws fixing the CMC.

Reactor

- 1 Remove 4 screws fixing the reactor.

Noise filter

- 1 Remove all the wiring connected to the noise filter.
- 2 Hold the upper part of the 6 holders with the long nose pliers and remove the noise filter.

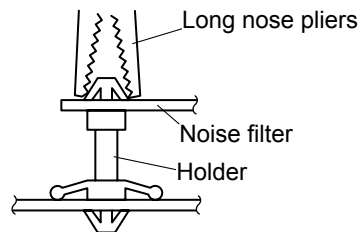

NOTE

When mounting components, be sure to match the wiring connections with the mark band codes.

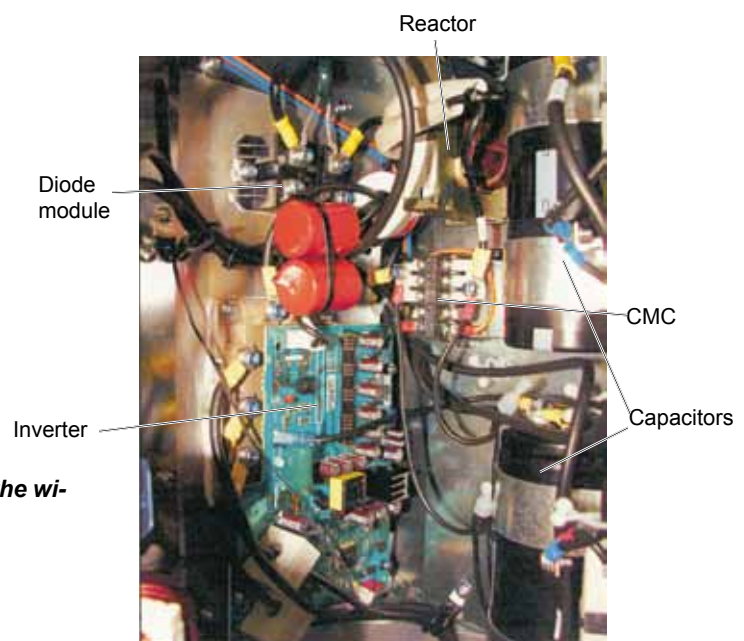

10.4.3 Outdoor Units RAS-12HNC

10.4.3.1 Removing service cover



NOTE

- Follow the procedure below to remove main parts and components. For mounting follow the reverse procedure of removal.
 - Do not expose the refrigerant cycle to the atmosphere for a long period to avoid moisture or dust entering into the cycle. Be sure to replace parts immediately after removing. Seal the refrigerant cycle when left unattached for a long period.
- 1 Remove the 5 fixing screws, slide the service cover downward and remove it.
 - Pay attention not to fall off the service cover.

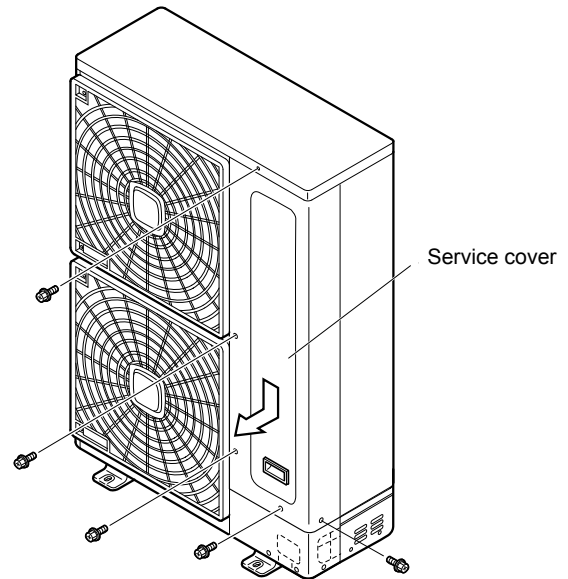

10.4.3.2 Removing air outlet grille

- 1 Remove the 8 fixing screws of the shroud.

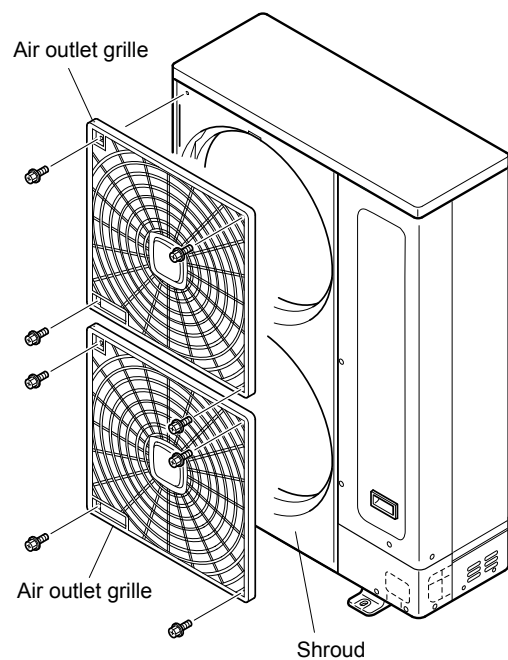

10.4.3.3 Removing upper cover

- 1 Remove 11 screws fixing the upper cover and remove the upper cover upward.

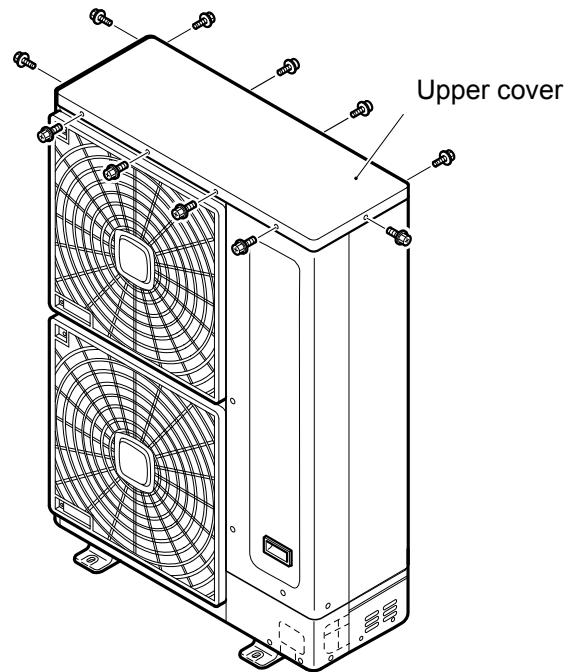

10.4.3.4 Removing the bottom service cover and rear cover

- 1 Remove 5 screws fixing the lower part of service cover and remove the lower part of service cover by pulling towards front side.
- 2 Remove the upper cover according to the item [Removing upper cover](#).
- 3 Remove 10 screws fixing panel and remove the rear panel by pulling in the arrow direction.

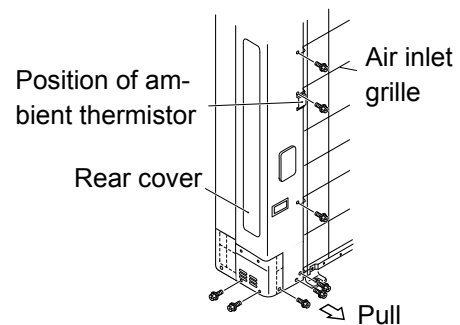
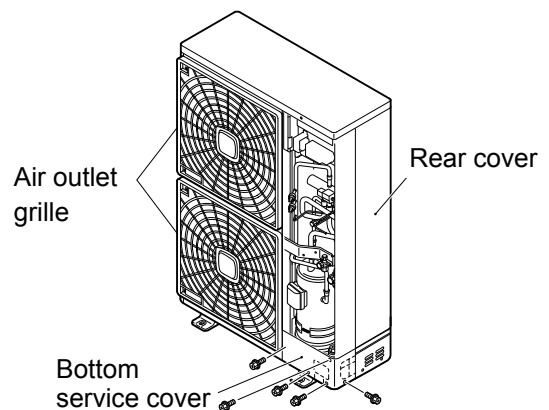

DO NOT touch electrical components while the LED1 (Red) is ON to avoid electrical shock. Wait until the LED turns off.

10.4.3.5 Removing outdoor fan motor

- 1 Remove the service cover following [Removing service cover](#).
- 2 Remove the outlet grille following [Remove outlet grille](#).
- 3 If necessary, remove the upper cover following [Removing upper cover](#).
- 4 To remove the propeller fan remove the cap nut and washer which fix the propeller fan onto the motor shaft. (Use a puller when the propeller fan and motor shaft are fixed too tightly).

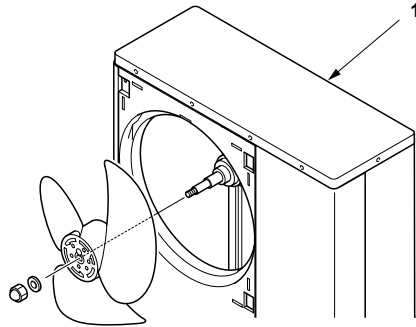

1. Upper cover.

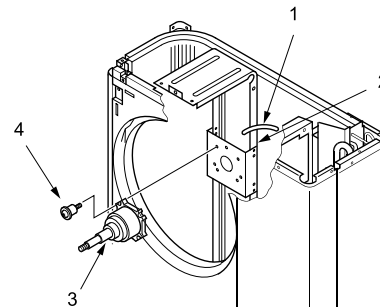

1. Fan motor lead wire.
2. Motor clamp.
3. Motor.
4. Screw with spacer.

- 5 Remove the fan motor connector from PCB in the electrical box.
Cut the plastic tie with nippers which fixes the fan motor lead wire onto the motor clamp.
Remove 4 screws which fix the motor.

Model		RAS-12HNC
Fan Motor Comp. N°	DC Fan Motor	Inverter PCB CN406 (Red)
	AC Fan Motor	inverter PCB PCN404 (White)
Screws for motor fixing.	DC Fan Motor	4 x M6 screw (with spacer)
	AC Fan Motor	4x M8 screws

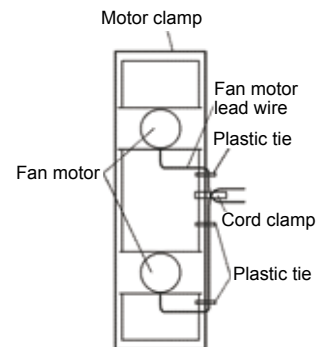

i NOTE

- 1 **To mount the motor be sure to place the lead wire outlet downward.**
(Adjust the propeller fan and shroud not to contact with each other).
- 2 **Fix the motor lead wire onto the motor clamp using a plastic tie as shown in the table on the previous page to avoid obstructing the propeller fan.**
- 3 **Mounting propeller fan:**
Insert the skidding protection part of the fan boss matching with the motor shaft notch; tighten the nut after the shaft screw fully comes out. (Tightening Torque 20 Nm)
- 4 **Connect the motor lead wire to PCB1 of the electrical box.**
(Be sure to match colors of the PCB connectors and motor lead wire connectors).
- 5 **Be sure to attach the outlet grill onto the shroud after replacing the fan motor.**

10.4.3.6 Removing electrical box

- 1 Remove the service cover following [Removing service cover](#).
- 2 Remove the upper cover following [Removing upper cover](#).
- 3 Remove 6 screws which fix the electrical box.
- 4 Pull up and remove the electrical box.

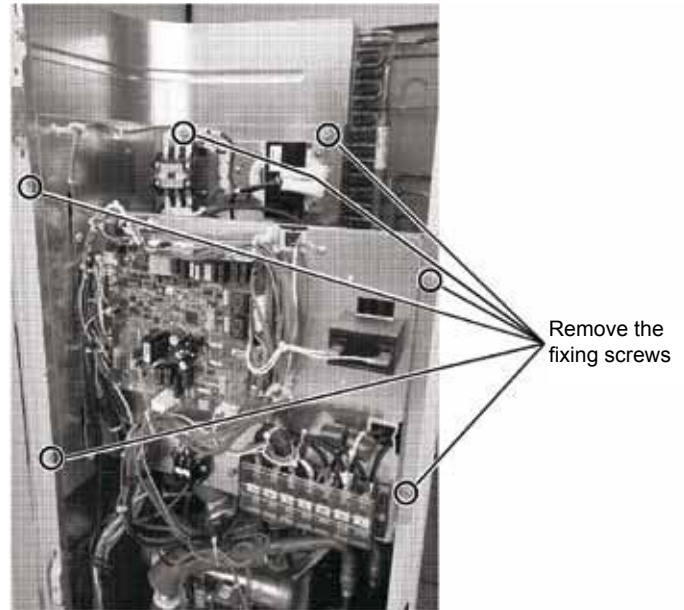

NOTE

The following wiring must be removed to dismantle the electrical box.

1. Remove the reversing valve coil from the reversing valve. : [Removing reversing valve coil](#).
2. Remove the expansion valve coil from the expansion valve. : [Removing electronic expansion valve coil](#).
3. Remove the solenoid valve coil from the solenoid valve. : [Removing solenoid valve coil](#).
4. Remove the Faston terminals of high pressure switch and the pressure switch for control from the switch body : [Removing the high pressure switch and pressure switch for control](#).
5. Remove all connectors on the control PCB.
6. Remove the compressor wires in the terminal box of the compressor.
7. To remount the electrical box attach the electrical box fitting with the partition plate.
(Insert the radiation fin into the U-notch on the partition plate and place the fin on the fan box side. Then attach the electrical box hooking onto the partition plate).

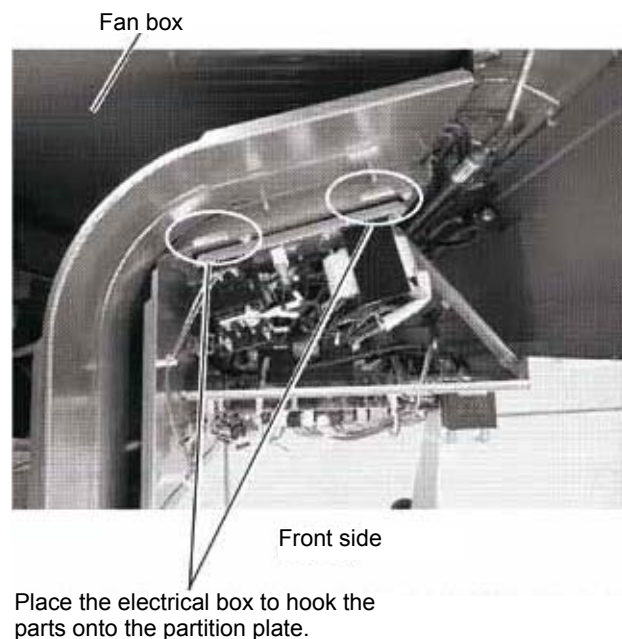
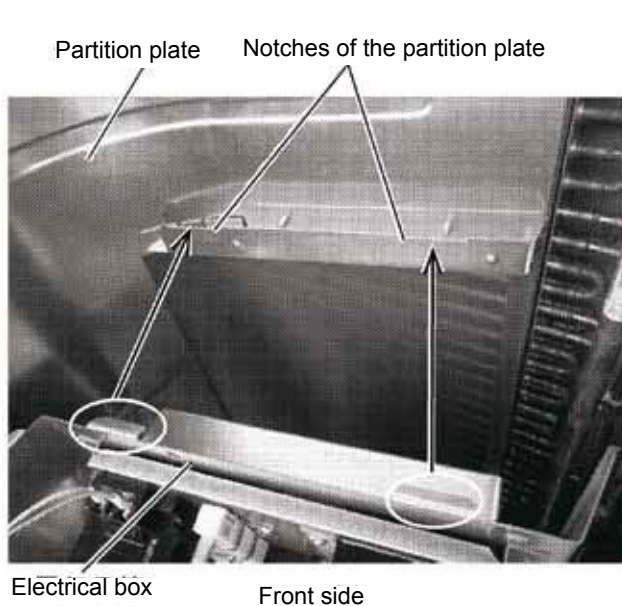

◆ Removing the compressor

- 1 Remove the service cover and the bottom service cover following [Removing service cover](#), and [Removing bottom service cover and rear cover](#).

When the outdoor unit is installed close to a wall remove the refrigerant piping and move the unit from the wall.

- 2 Collect the refrigerant from the check joint.



NOTE

Check Perform the recovery work at the check joint of piping. If not, the refrigerant remains inside.

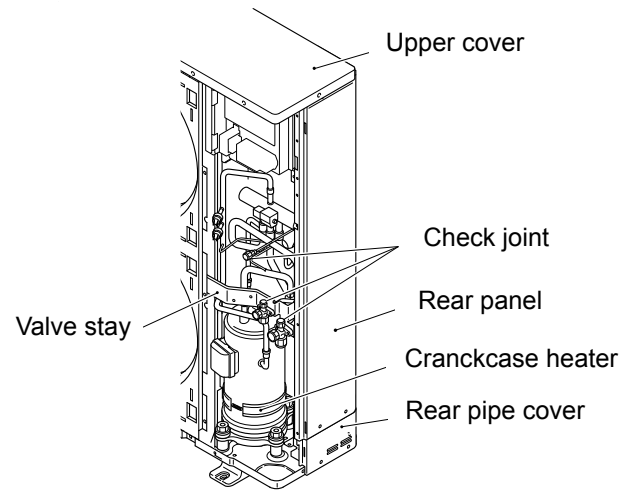

- 3 Open the soundproof cover wrapped around the compressor and remove the terminal box cover of the compressor body. Disconnect the compressor wires in the terminal box and disconnect the thermistor on top of the compressor. Remove the soundproof cover.



NOTE

Check the terminal codes and mark bands when disconnecting the wires. Connecting wires in wrong order at reassembling may result in compressor damage.

- 4 Remove the rubber cap and the thermistor attached on top of the compressor.
- 5 Remove the crankcase heater.

1. Sound-proof cover.

2. Oil heater.

3. Cut part.

A. Direction to remove the cover.

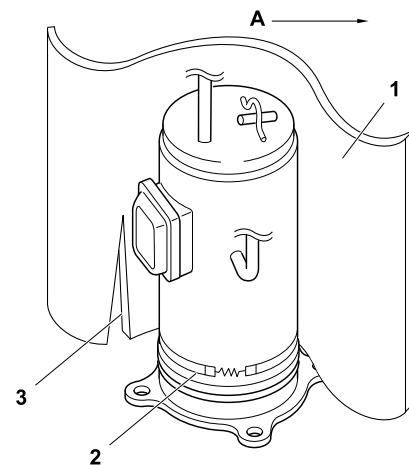

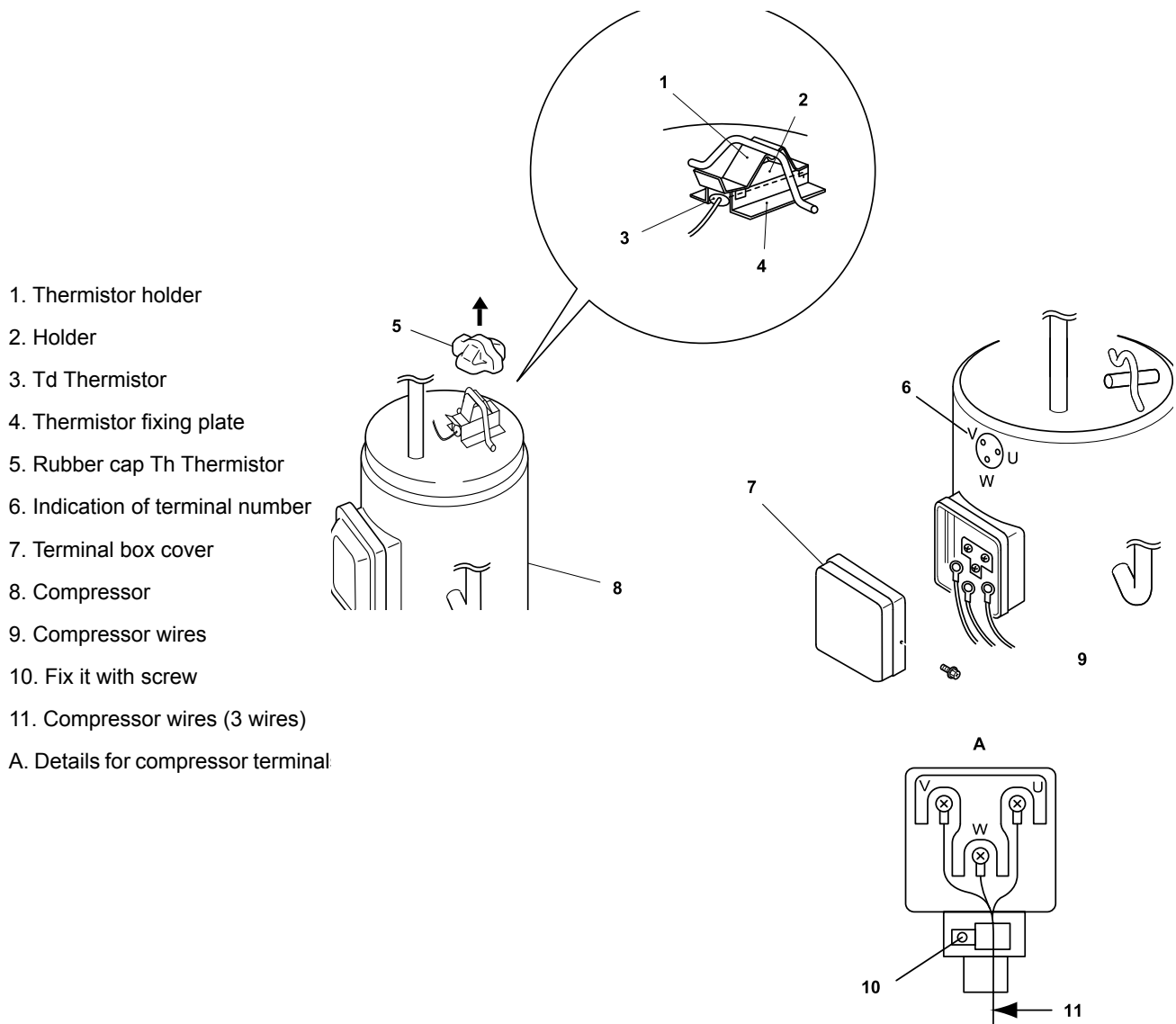

i NOTE

- **Compressor piping must be connected by brazing. MAKE SURE that any flammable material is not around before heating with burner for the oil inside the piping may flame up.**
 - **Do not expose the refrigerant cycle to the atmosphere for a long period to avoid moisture or dust into the cycle. Be sure to replace the compressor immediately after removing. Seal the suction and discharge pipes when the refrigerant cycle is left unattached for a long period.**
 - **Remove the cap of new compressor right before the replacement. Before mounting the compressor seal the suction and discharge pipes with a tape to protect the compressor from dust. Remove the tape when blazing the pipe.**
 - **For piping at reassembling ensure that the compressor terminal numbers and wiring mark band codes are matched. Incorrect wiring numbers may result in inverse rotation and damage of the compressor.**
- 6 Remove the suction pipe and discharge pipe from the compressor.

i NOTE

Be sure to separate the blazing burner flame sufficiently from the wires and electrical components around the brazed part in order to avoid burning.

- 7 Remove 2 nuts which fix the compressor and remove it by lifting it up with inclining forward.

i NOTE

To remove the compressor the liquid stop valve pipe should be moved (bent) to the right side hand. **PAY CLOSE ATTENTION not to crush to break the pipe.**

- 8 When brazing the replaced compressor quickly perform the brazing while the compressor side piping is cooled with wet cloth in order to avoid the brazing material from entering the compressor.

i NOTE

PAY CLOSE ATTENTION not to let the filler metal enter into the compressor which may result in compressor damage.

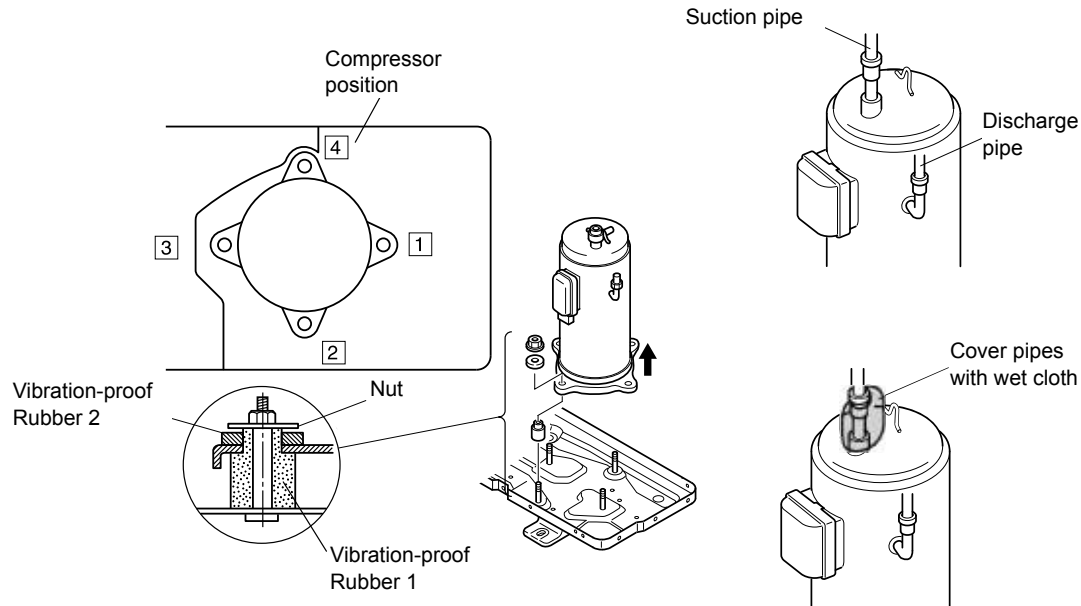

Fixation of the compressor to the bottom plate				
Compressor position	1	2	3	4
Vibration-proof rubber 1	x	x	x	x
Vibration-proof rubber 2	x	x	—	—
Nut	x	x	—	—

- 9 Reassemble the parts in the reverse order of removing procedures.

- Tighten the screws (U V and W) for compressor wires with 2.5 Nm.
- Fix the wires firmly.
- Attach the crankcase heater without torsion and gap to the compressor as following figure.

Detail of Spring for Crankcase Heater

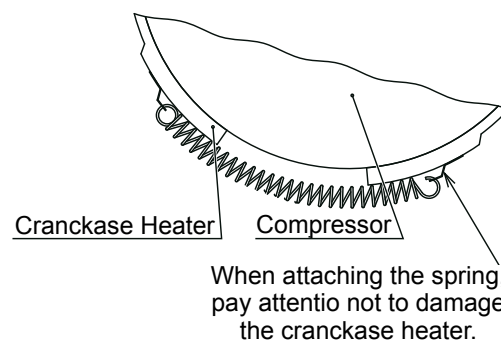

10.4.3.7 Removing High pressure switch and pressure switch for control

- 1 Remove the service cover following [Removing service cover](#) in this chapter.
- 2 Collect the refrigerant from the check joint according to [Removing the compressor](#), in this chapter.
- 3 Disconnect the Faston Terminals of High Pressure Switch and Pressure sensor for PD control.
- 4 Remove the high pressure switch and the pressure switch for control from the brazed part of discharge piping.

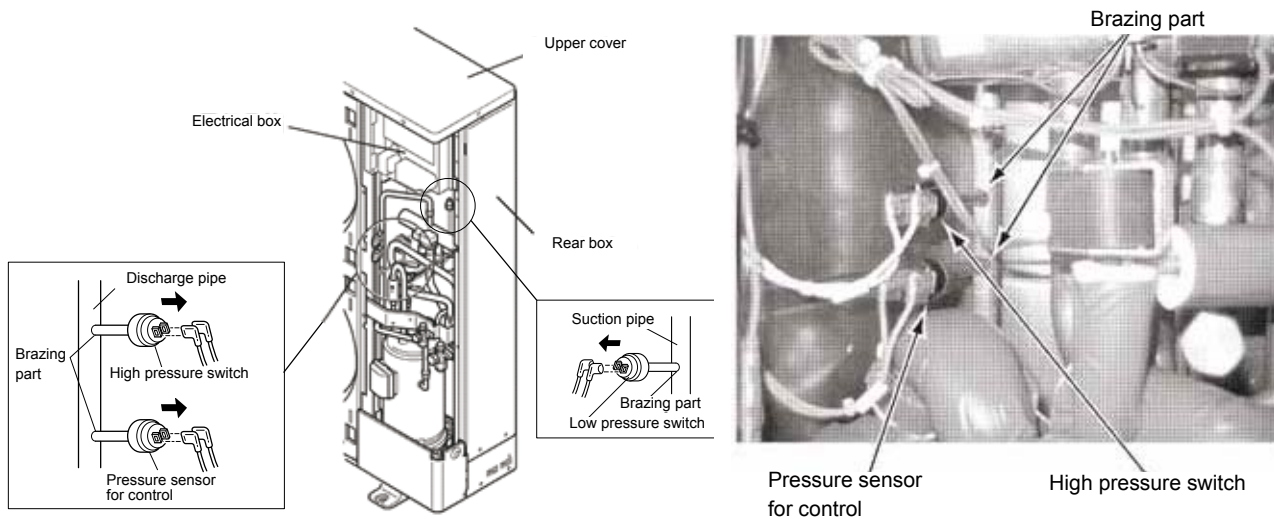

10.4.3.8 Opening electrical box (P-Mounting Plate)

- 1 Remove the service cover following [Removing service cover](#) in this chapter.
- 2 Remove 5 screws which fix the electrical box and open the P plate turning counter clockwise approximately 90°.
 - Check that the LED201 (red) on the inverter PCB (PCB2) is OFF when opening P-mounting plate.

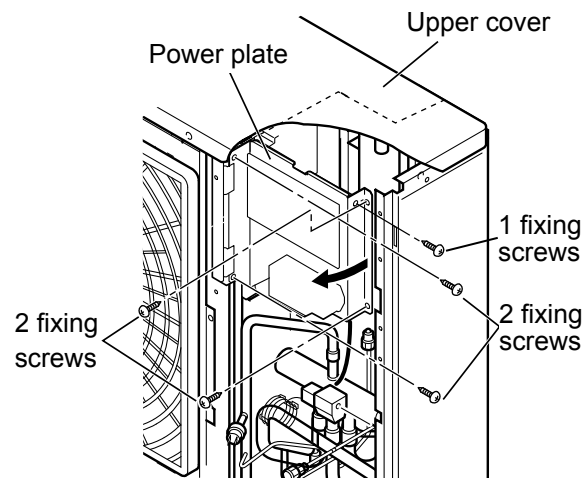

DANGER

DO NOT touch electrical components while the LED201 (Red) or LED1 (Red) are ON to avoid electrical shock. Wait until the LEDs turn off.

10.4.3.9 Removing reversing and solenoid valves coils

- 1 Remove the service cover following [Removing service cover](#) in this chapter.



DANGER

DO NOT touch electrical components while the LED1 (Red) is ON to avoid electrical shock. Wait until the LED turns off.

- 2 Remove the connectors on the control PCB (PCB1) of the electrical box according to the following picture.
- 3 Remove the valve coils by removing 1 fixing screw for each coil.

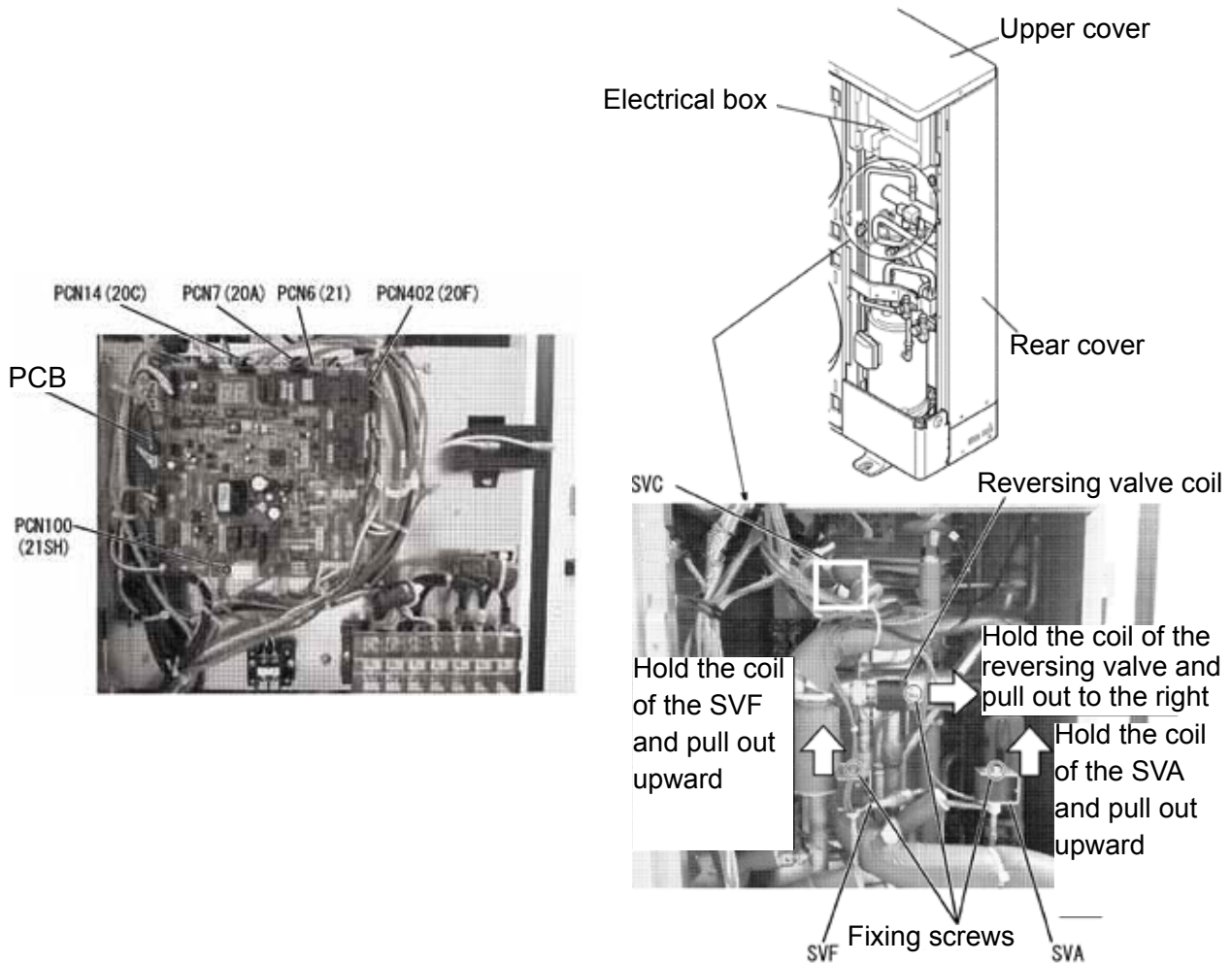

- 4 When reassembling, perform the procedure in the reverse way of removing.



NOTE

Fix the wires by plastic bands to the original position.

10.4.3.10 Removing electronic expansion valve coil

- 1 Remove the service cover, the bottom service cover and the rear cover following *Removing service cover* and *Removing bottom service cover and rear cover*.
- 2 Open the P plate turning counter clockwise approximately 90° following *Opening electrical box (P plate)*.
 - Check that the LED201 (red) on Inverter is OFF when the P plate is opened.



DANGER

DO NOT touch electrical components while the LED201 (Red) or LED1 (Red) are ON to avoid electrical shock. Wait until the LEDs turn off.

- 3 Disconnect the CN5A connector on the control PCB1 of the electrical box.
- 4 Hold the coil of the expansion valve and pull out upward.
It is easier to remove the expansion valve coil if it is rotated while pulling it upward.
- 5 When reassembling after replacing the expansion valve coil, perform the procedure in the reverse way of removing. The expansion valve coil is equipped with a lock mechanism. After attaching the expansion valve coil, rotate it until the sound of locking is heard.

NOTE

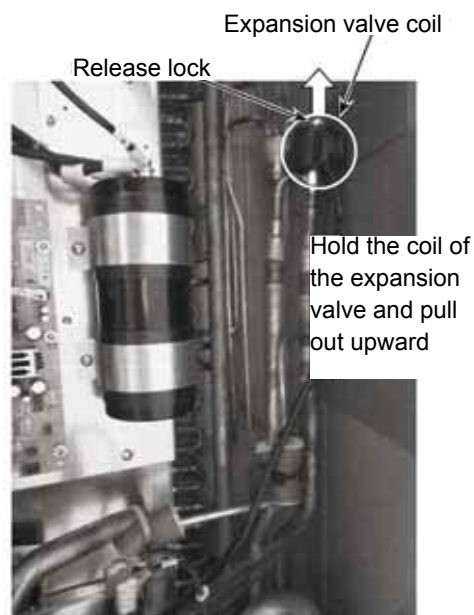
Fix the wires by plastic bands to the original position.



DANGER

DO NOT touch electrical components while the LED201 (Red) or LED1 (Red) are ON to avoid electrical shock. Wait until the LEDs turn off.

10.4.3.11 Removing reversing valve

- 1 Remove the service cover, the bottom service cover and the rear cover following *Removing service cover* and *Removing bottom service cover and rear cover*.
- 2 Remove the reversing valve coil according to *Removing Reversing Valve Coil*.
- 3 Recover the refrigerant from check joints according to *Removing Compressor*.
- 4 Remove the reversing valve assemblies from the fixed positions (4 brazing parts and 1 flare connection).
 - a. Remove the reversing valve and the stop valve with cooling the valve bodies by wet cloth.
 - b. Perform the brazing work with attention not to burn the electrical wirings and the piping insulations.
- 5 Remove reversing valve from the assemblies. (4 brazing parts and 1 flare connection) At this time, perform the brazing work with cooling the reversing valve body by wet cloth.
- 6 When reassembling after replacing the reversing valve, perform in the reverse procedure of removing.
 - a. Run the lead wires to be located to the original position, and fix them by the plastic band.
 - b. Attach the crankcase heater according to *Removing Compressor*.
- 7 Reassemble the parts in the reverse order of removing procedures.

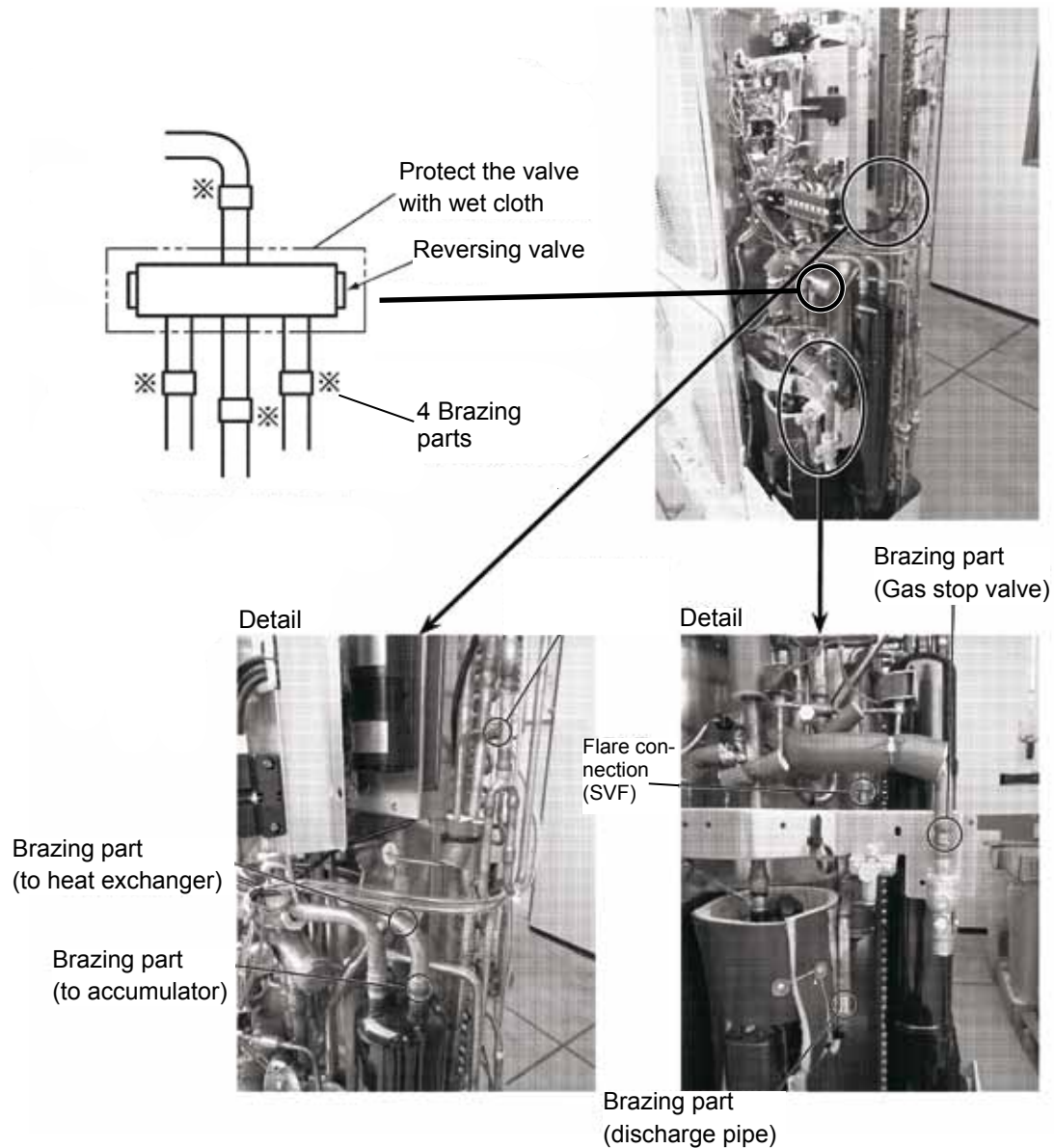

10.4.3.12 Removing Electronic expansion Valve and Solenoid Valve

- 1 Remove the service cover, the bottom service cover and the rear cover following *Removing service cover* and *Removing bottom service cover and rear cover*.
- 2 Recover the refrigerant from check joints according to *Removing Compressor*.
- 3 Remove the coils according to *Removing Electronic Expansion Valve Coil* and *Removing Reversing and Solenoid Valves Coils*.

Removing electronic expansion valve

- 1 Remove the brazed parts as shown in the figure.
 - Electronic Expansion Valve (EVO) Brazed Parts: 2
 - a. Remove the electronic expansion valve with cooling the valve bodies by wet cloth.
 - b. Perform the brazing work with attention not to burn the electrical wirings and the piping insulations.

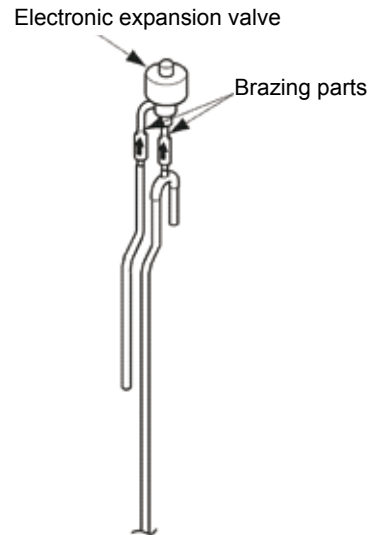

- 2 When reassembling after replacing the valves, perform in the reverse procedure of removing.



Run the lead wires to be located to the original position, and fix them by the plastic band.

Removing solenoid valves

- 1 Remove the brazed parts and the flare connections as shown in the figures.
 - Solenoid Valve (SVA) Brazed Parts: 2
 - Solenoid Valve (SVC) Brazed Parts: 2
 - Solenoid Valve (SVF) Flare connections: 2
 - a. Remove the solenoid valves with cooling the valve bodies by wet cloth.
 - b. Perform the brazing work with attention not to burn the electrical wirings and the piping insulations.
 - c. Perform the flare connection work using two spanners to avoid twisting pipes.

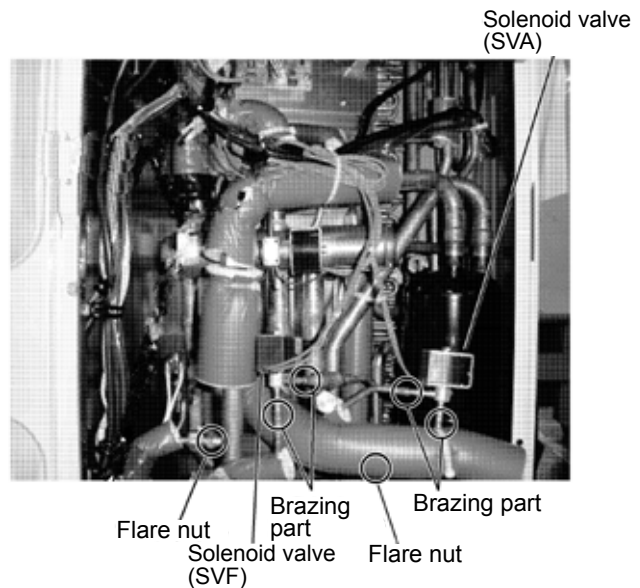

- 2 When reassembling after replacing the valves, perform in the reverse procedure of removing.



Run the lead wires to be located to the original position, and fix them by the plastic band

10.4.3.13 Removing electrical components

◆ Removing control PCB (PCB1)

- 1 Remove the service cover following [Removing service cover](#).
- 2 Remove all the wiring connected to the control PCB.



DANGER

DO NOT touch electrical components while the LED1 (Red) is ON to avoid electrical shock. Wait until the LED turns off.

- 3 Remove the 6 holders. Clamp the middle part of the holders with long-nose pliers and remove it toward front side.



DANGER

DO NOT touch the electrical components on the PCB. Pay attention not to bend or apply much force onto PCB in order to avoid PCB failure.

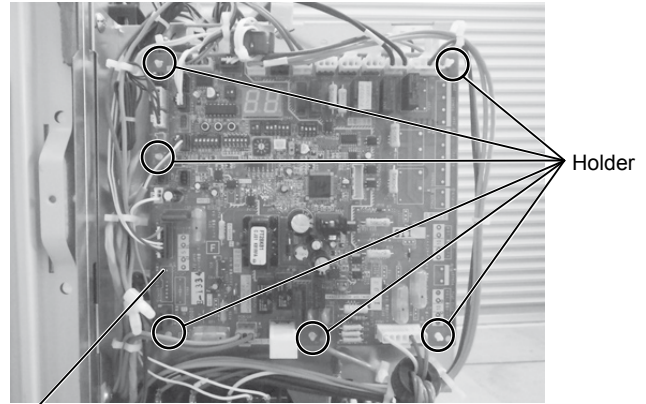

Printed Circuit Board (PCB1)

◆ Removing Inverter module

- 1 Remove the service cover following [Removing service cover](#).
- 2 Open the P plate turning counter clockwise approximately 90° following [Opening electrical box \(P plate\)](#).
 - Check that the LED201 (red) on Inverter is OFF when the P plate is opened.



DANGER

DO NOT touch electrical components while the LED201 (Red) or LED1 (Red) are ON to avoid electrical shock. Wait until the LEDs turn off.

- 3 Remove 4 screws M3, remove the bushes and remove the spacers fixing the inverter.



NOTE

When mounting again be sure to place the bushes and spacers.

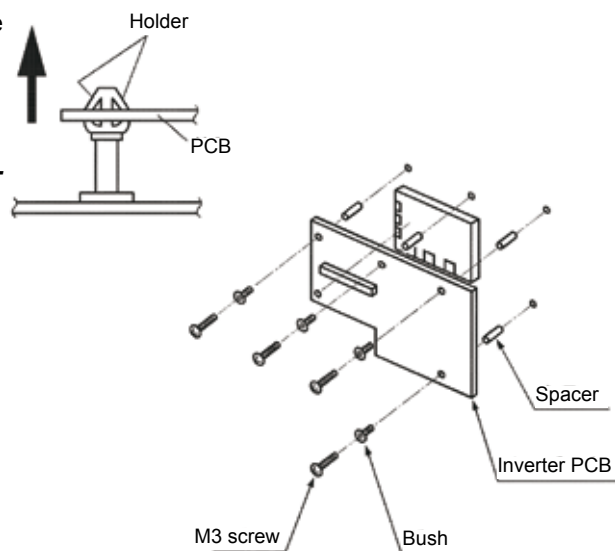

Removing Diode Module (DM)

- 1 Disconnect the wirings of terminal + - U V W on the diode module.
- 2 Remove 2 M5 fixing screws on the diode module.
- 3 Remove the diode module from the electrical box.

- 1: 5 Screws (M5)
- 2: Fixing screw (M5)

**Removing Transistor Module (IPM)**

- 1 Disconnect all the wirings connected to the transistor module.
- 2 Remove the connectors CN2, CN3, CN206, PCN301 and PCN302 from the transistor module.
- 3 Disconnect the wirings of P N U V W on the transistor module.
- 4 Remove 4 M4 fixing screws on the transistor module.
- 5 Remove the transistor module from the electrical box.

1. Screws for transistor module (M4)
2. Screw (M5)
3. PCN301
4. PCN302
5. Screws for PCB (M3)
6. CN3
7. Inverter PCB
8. CN206
9. CN2
10. LED201

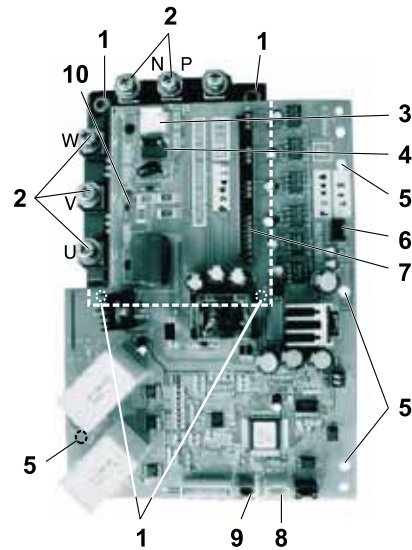

- 6 Reassemble the parts in the reverse order of removing order.



Identify terminal with the mark band when reassembling to avoid incorrect wiring.

10.4.3.14 Removing other electrical components

- 1 Remove the service cover following [Removing service cover](#) in this chapter.
- 2 Open the P plate turning counter clockwise approximately 90° following [Opening electrical box \(P plate\)](#).
 - Check that the LED201 (red) on Inverter is OFF when the P plate is opened.



DANGER

DO NOT touch electrical components while the LED201 (Red) is ON to avoid electrical shock. Wait until the LED turns off.

Capacitors

- 1 Remove all the wiring connected to the capacitors.



NOTE

The wires have polar characters. Identify the wire mark band and the indication on the capacitor when connecting wires.

- 2 Remove 2 screws fixing the capacitors.

CMC

- 1 Remove all the wiring connected to CMC.
- 2 Remove 3 screws fixing the CMC.

Reactor

- 1 Remove 4 screws fixing the reactor.

Noise filter

- 1 Remove all the wiring connected to the noise filter.
- 2 Hold the upper part of the 6 holders with the long nose pliers and remove the noise filter.

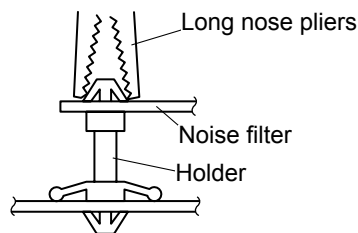

NOTE

- **To connect wiring at reassembling, ensure that the terminal numbers and wiring mark band codes are matched. If connections are wrong, there is the possibility of wrong operation and to cause damage to electrical parts.**
- **From the Power Wires (U Phase, V Phase, W Phase) of Inverter Compressor (MC1), please make sure that the 2 wires of U Phase and V Phase pass through the current sensors (CTU • CTV) of Inverter PCB (PWB3). Also make sure that the Power Wire of U Phase is connected to the U Phase side of current sensor (CTU), and that V Phase is connected to the V Phase side of current sensor (CTV). If the combination is wrong, it could be a cause of wrong operation and damage.**
- **When attaching the PCB, or when attaching the parts attached to the PCB, pay attention not to clamp any wiring between plates or electrical components.**
- **Screws, Bushes and Collars are used to fix the Inverter PCB. Please use Bushes and Collars without fault when attaching the Inverter PCB. Failure to do so may cause wrong operation.**
- **When replacing the Control PCB, please set the Dip Switches with the same configuration as the PCB before replacement. Wrong settings may cause wrong operation. Also, please confirm the replacement instructions supplied with the PCB sold as a service part.**
- **Do not apply too much force to the electrical parts mounted on the PCB or to the PCB itself. It may cause failure of the PCB.**

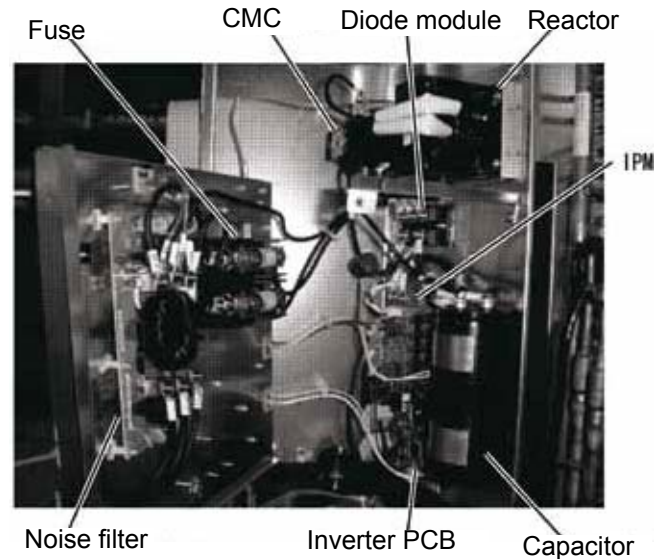

11 . Electrical checks of main parts

Index

11.1. Inverter	440
11.1.1. Specifications of inverter	440
11.1.2. Inverter time chart.....	442
11.1.3. Protective function	443
11.1.4. Overload control	444
11.2. Thermistor	445
11.3. Electronic expansion valve.....	447
11.4. High pressure protection device.....	448
11.5. Noise filter (NF)	450
11.5.1. Noise filter for 3N~ (400V/50Hz)	450
11.5.2. Noise filter for 1~ (230V/50Hz).....	451
11.6. Capacitor (CB1 CB2).....	452
11.7. Reactor (DCL)	453
11.7.1. Reactor (DCL) for 3N~ (400V/50Hz)	453
11.7.2. Reactor (DCL) for 1~ (230V/50Hz).....	453
11.8. Scroll compressor.....	454
11.8.1. Reliable mechanism for low vibrating and low sound.....	454
11.8.2. Principle of compression	454

11.1 Inverter

11.1.1 Specifications of inverter

Applicable model	RAS-(4-6)HNPE	RAS-(4-6)HNCE	RAS-(8-12) HN(P/C)(E)	RAS-(2-2.5)HVNP RAS-3HVNC	RAS-3HVNPE	RAS-(4-6)HVNPE	RAS-(4-6)HVNCE
Applicable power source	3 Phase 400V 50 Hz			1 Phase. 230V 50 Hz			
Output current	24.0A	16.0A	45.0A	10.5A	16.0A	24.0A	16.0A
Control Method	Vector control						
Range output frequency	20-115HZ			31-115HZ	20-115HZ		15-115HZ
Accuracy of frequency	0.01Hz at applicable frequency range						
Output / characteristics	Conditions: 1 Power source voltage AC380/415V 2 Non-loading (free output) 3 Ammeter type volt-meter (X1.1)			Conditions: 1 Power source voltage AC220/240V 2 Non-loading (free output) 3 Ammeter type volt-meter (X1.1)			
Soft start stop	0.125–3.00 Hz/s						

Protection function							
Applicable model	RAS-(4-6)HNPE	RAS-(4-6)HNCE	RAS-(8-12) HN(P/C)(E)	RAS-(2-2.5)HVNP RAS-3HVNC	RAS-3HVNPE	RAS-(4-6)HVNPE	RAS-(4-6)HVNCE
Excessive high or low voltage for inverter	Excessive low voltage at a voltage is lower than 350 V DC Excessive high voltage at a voltage is higher than 750 V DC			Excessive low voltage at a voltage is lower than 194 V DC Excessive high voltage at a voltage is higher than 400 V DC			
Abnormality of current sensor (0A detection)	Stoppage at a current of compressor smaller than 1.5A. When the frequency is 15 to 18Hz after starting. Cause of abnormality: Failure of current sensor Failure of IPM/DIP-IPM/ ISPM Failure of compressor / fan motor Disconnected wiring			—			
Overcurrent protection for inverter	<p>1 Short-circuit trip of arm *) 2 Instantaneous overcurrent trip *) 3 Instantaneous overcurrent trip 4 Electronic thermal trip</p> <p>*) Internal protection IPM</p> <p>Condition is maintained longer than 30 seconds or accumulated longer than 3 minutes during 10 minutes sampling time.</p>						
Protection of transistor module	IPM has four protection function for self-protection. 1 Some of the output terminals between "U" and "V" "V" and "W" "W" and "U" has a short-circuit. 2 Running current reaches the maximum rated current. 3 Abnormal temperature is measured by internal thermistor (for 8 to 12HP). 4 Control voltage decreases abnormally.						
Overload control	Overload control as a current greater than (rated current X105%). Overload control release at a current smaller than (rated current X 88%).						
Fin temperature increase	The unit is stopped when the fin temperature is higher than 80°C (for 3HP), 90°C (for 4 to 6HP Premium), 92°C (for 4 to 6HP Standard) or 100°C (for 8 to 12HP).						
Earth detection	The unit is stopped when the compressor is earthing.						

11.1.2 Inverter time chart

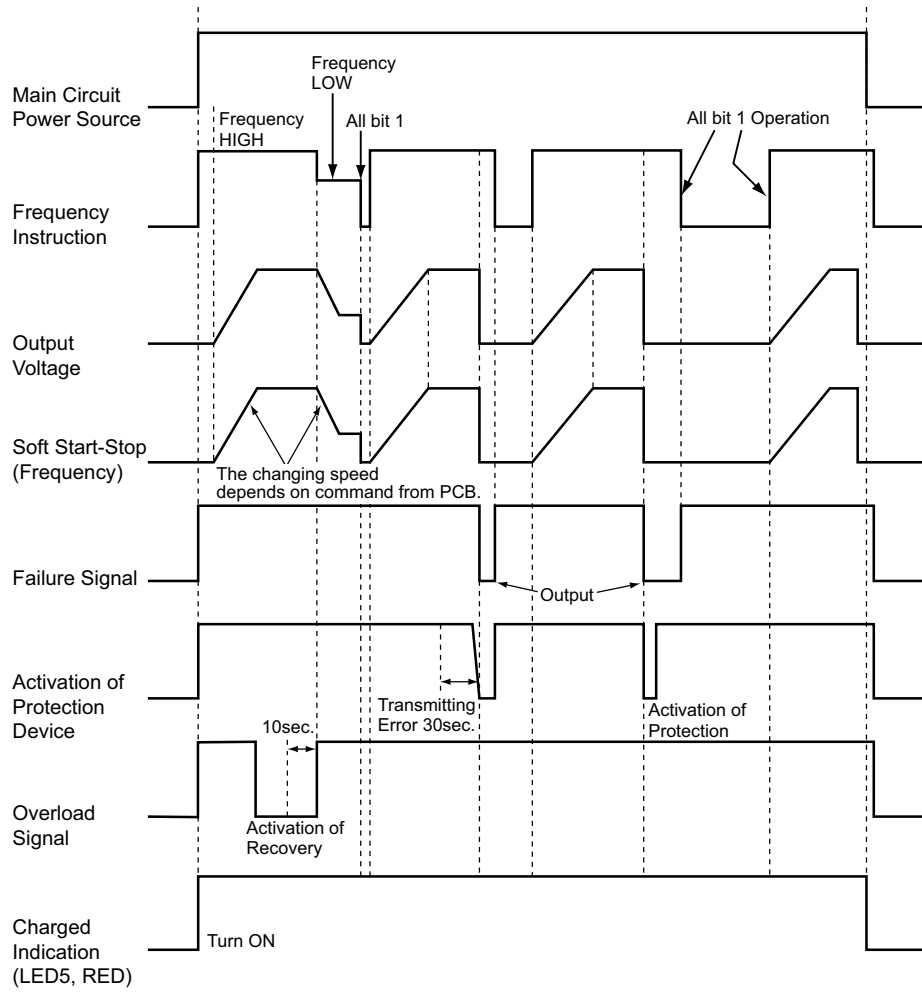

11.1.3 Protective function

1 Excessive high or low voltage for inverter

a. Level of detection

- When the voltage of direct current is greater than (A) V abnormalities are detected.
- When the voltage of direct current is smaller than (B) V abnormalities are detected.

Power supply	400V 50Hz	230V 50Hz
(A)	750	440
(B)	350	194

b. Function

When abnormalities are detected the inverter compressor is stopped and transmit the signal code of stoppage cause to PCB1.

c. Cancellation of protection function.

Transmission for signal code of stoppage cause is cancelled when a stopping order is given or main power source is cut off.

2 Abnormality of current sensor

a. Level of detection

When current of the inverter compressor decreases lower than 1.5A during the inverter compressor frequency between 15Hz and 18Hz an abnormality is detected.

b. Function

When abnormalities are detected the inverter compressor is stopped and transmit the signal code of stoppage cause to PCB1.

c. Cancellation of Protection Function

Transmission for signal code of stoppage cause is cancelled when a stopping order is issued or main power source is cut off.

3 Overcurrent protection for inverter

a. Level of detection

When the current detected by current sensor reaches 150% of the rated current overcurrent is detected. (Instantaneous overcurrent).When the current detected by current sensor exceeds 105% of the rated current continuously for 30 seconds or for 3.5 minutes in total during a 10 minutes period overcurrent is detected. (Electric thermal relay).

b. Function

When abnormalities are detected the inverter compressor is stopped and transmit the signal code of stoppage cause to PCB1.

c. Cancellation of protection function

Transmission for signal code of stoppage cause is cancelled by stopping order is issued or main power source is cut off.

4 Protection of IPM/DIP-IPM/ISPM

a. Level of detection

When some of the output terminals between "U" and "V" "V" and "W" "W" and "U" of IPM/DIP-IPM/ISPM are short-circuited an abnormality is detected.When the running current of IPM/DIP-IPM/ISPM reaches (maximum rated current x 105%) an abnormality is detected.When an internal temperature is measured by internal thermistor of IPM an abnormality is detected.When the control voltage of IPM/DIP-IPM/ISPM decreases an abnormality is detected.

b. Function

When abnormalities are detected the inverter compressor is stopped and the signal code of stoppage cause is transmitted to PCB1.

c. Cancellation of protection function

Transmission for signal code of stoppage cause is cancelled when a stopping order is issued or main power source is cut off.

5 Fin temperature increase**a. Level of detection**

When the temperature of internal thermistor exceeds more than 80°C (for 3HP), 90°C (for 4 to 6HP Premium), 92°C (for 4 to 6HP Standard) or 100°C (for 8 to 12HP) an abnormality is detected.

b. Function

When abnormalities are detected the inverter compressor is stopped and the signal code of stoppage cause is transmitted to PCB1.

c. Cancellation of protection function

Transmission for signal code of stoppage cause is cancelled when a stopping order is issued or main power source is cut off

6 Earth detection**a. Level of detection**

When the starting current of the compressor reaches 80% of the overcurrent protection value an abnormality is detected.

b. Function

When abnormalities are detected the inverter compressor is stopped and the signal code of stoppage cause is transmitted to PCB1.

c. Cancellation of protection function

Transmission for signal code of stoppage cause is cancelled when a stopping order is issued or main power source is cut off.

11.1.4 Overload control**1 Level of detection**

When the output current exceeds 105% of the maximum output current an abnormality is detected.

2 Function

An overload signal is issued when output current exceeds 105% of the maximum output current and the frequency decreases.

For 10 seconds after the output current decreases lower than 88% of the rated current the operation is performed with the compressor frequency limited to the upper level frequency when the output current decreases lower than 88% of the rated one.

However if the frequency order is smaller than the maximum value the operation is performed according to the order.

3 Cancellation of protection function

After the operation described in the above item 2. is performed for 10 seconds this control is cancelled.

11.2 Thermistor

Thermistors for the outdoor unit

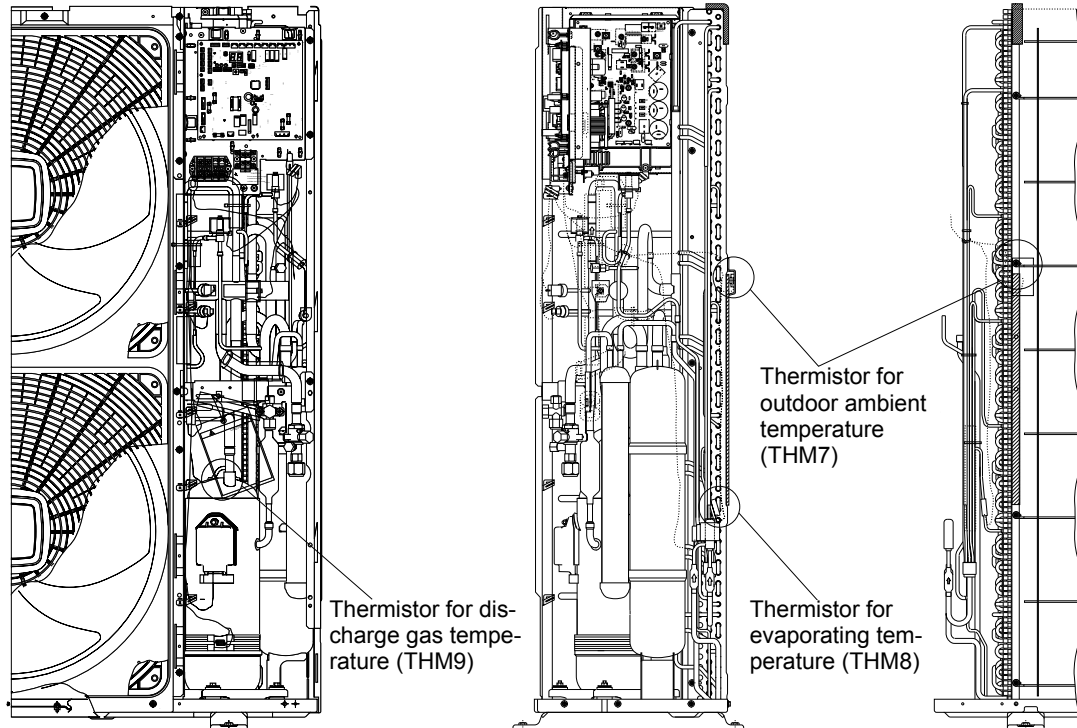

Thermistor for upper part temperature of compressor

(For prevention of discharge gas overheating)

- 1 A thermistor for the upper part temperature of the compressor is installed to prevent discharge gas from overheating. If discharge gas temperature increases excessively lubricating oil deterioration occurs and lubricating properties deteriorate resulting in short compressor life.
- 2 If discharge gas temperature increases excessively compressor temperature increases. At the worst compressor motor winding will be burnt out.
- 3 When the upper part temperature of compressor increases during heating operation the unit is controlled according to the following method.
 - An electronic expansion valve of outdoor units is (are) opened to return the liquid refrigerant to the compressor through the accumulator decreasing compressor temperature.
 - If the compressor upper part temperature increases exceeding 132 °C even if an electronic expansion valve opens the compressor is stopped in order to protect the compressor. In cooling operation the above function is also available.

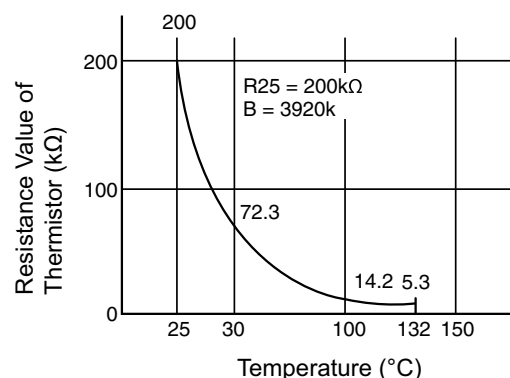

- 4 If compressor upper part temperature increases excessively the protection control is activated and the compressor is stopped according to the following method.

Operation	Upper part temperature of compressor	Defecting period
Cooling	Over 132 °C	10 minutes (continuously)
	Over 140 °C	5 seconds (continuously)
Heating	Over 132 °C	10 minutes (continuously)
	Over 140 °C	5 seconds (continuously)
Defrosting	Over 132 °C	5 seconds (continuously)

Thermistor for outdoor ambient temperature

The thermistor resistance characteristics are shown in the figure below.

Thermistor for evaporating temperature of outdoor unit in heating operation (for defrosting)

The characteristics for the thermistor is the same with the value of outdoor ambient temperature thermistor as shown in the figure below.

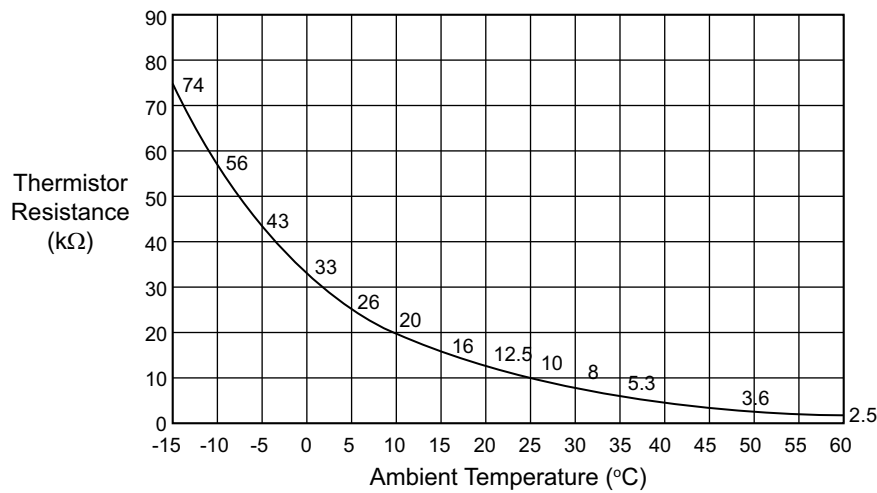

11.3 Electronic expansion valve

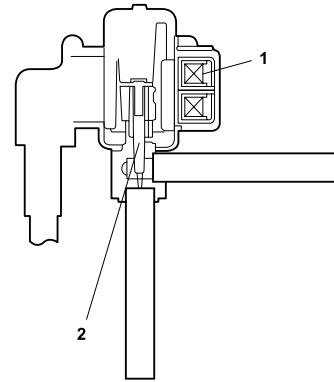
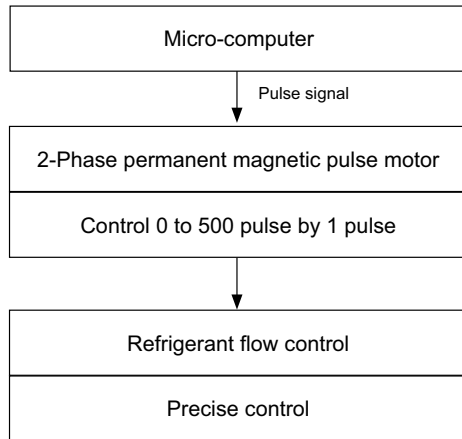

1. Pulse motor.
2. Needle.

Items	Specifications
Type	UKV series
Refrigerant	R410A
Working temperature range	-30 °C 70 °C (operation time of the coil: less than 50%)
Mounting direction	Drive shaft in vertical direction within an angle of 45 °C as maximum
Flow direction	Reversible
Drive method	4-Phase canned motor method
Rated voltage	DC12V±1.8 V
Drive condition	63PPS 1.2 phase excitation
Coil resistance (each phase)	46Ω ± 10 (at 20 °C)
Wiring diagram drive circuit and activation mode	1. Drive circuit. 2. Wiring diagram. 3. Valve. 4 . Close. 5 . Open. 6 . Activation.

11.4 High pressure protection device

If the discharge pressure is excessively high the compressor and the component parts of the refrigeration cycle can be damaged.

- High Pressure Switch:

In case that the discharge pressure is higher than 4.15 MPa (R410A) the protection control is activated and the compressor is stopped.

- Pressure Switch for Control:

In case that the discharge pressure is higher than 3.6 MPa (R410A) the protection control might be performed.

RAS-(2-2.5)HVNP / RAS-3HVNC

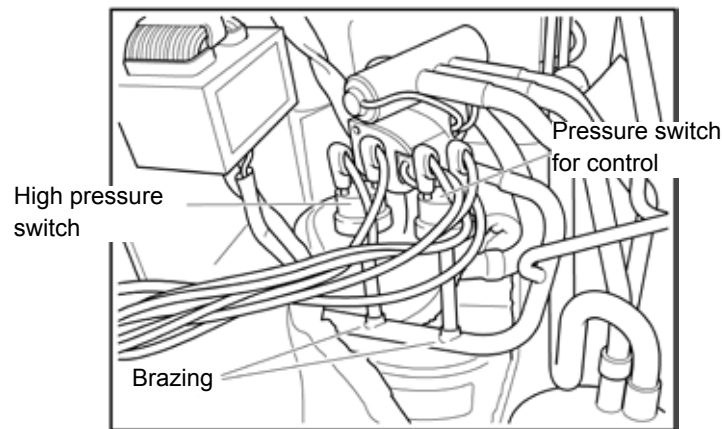

RAS-3HVNPE

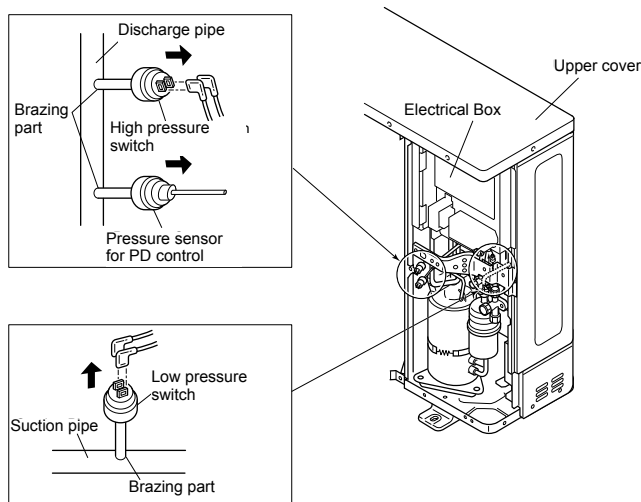

RAS-(4-6)H(V)NPE

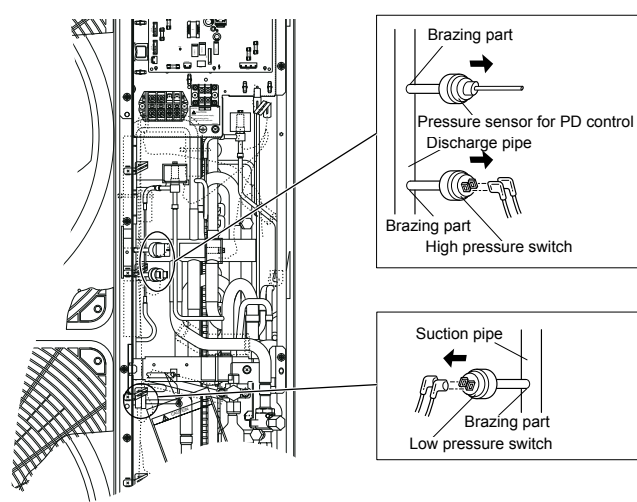

RAS-4H(V)NCE

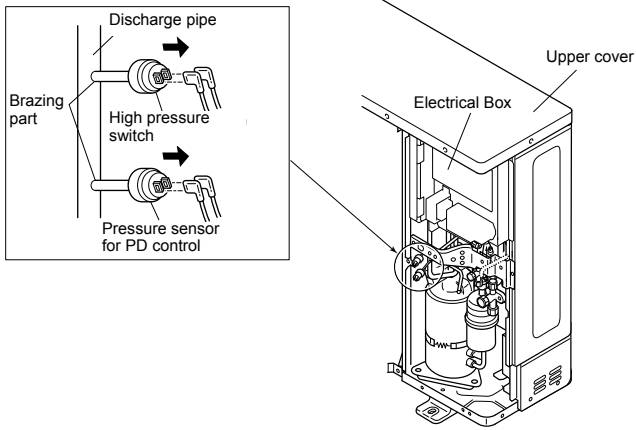

RAS-(5-6)H(V)NCE

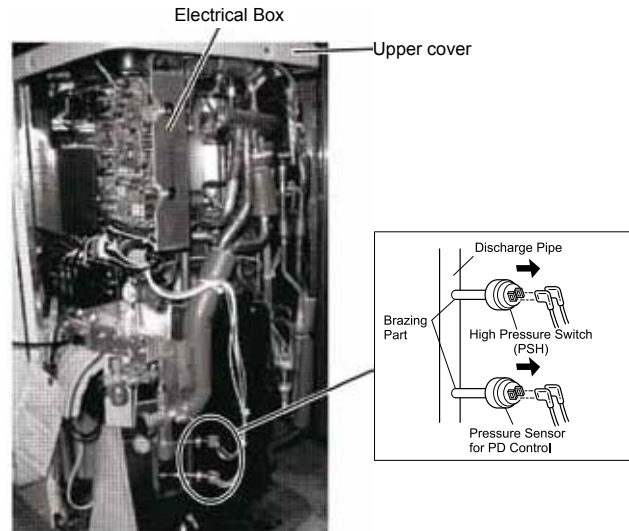

RAS-(8-10)HNPE

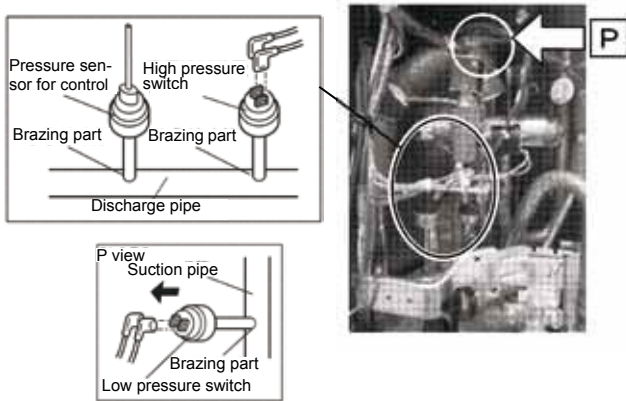

RAS-(8-10)HNCE

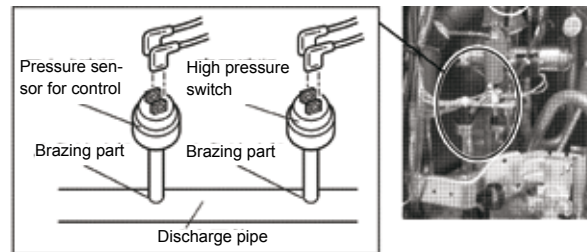

RAS-12HNP

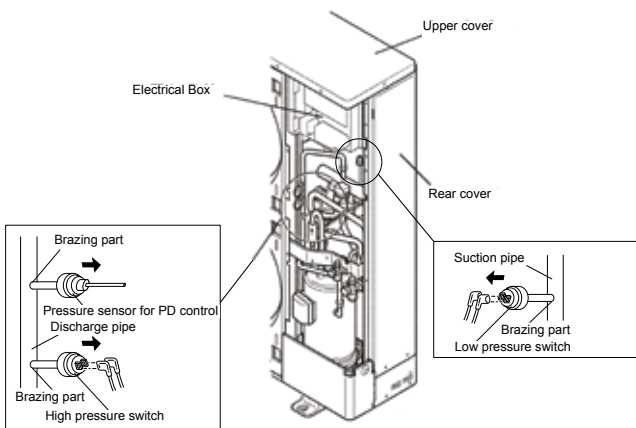

RAS-12HNC

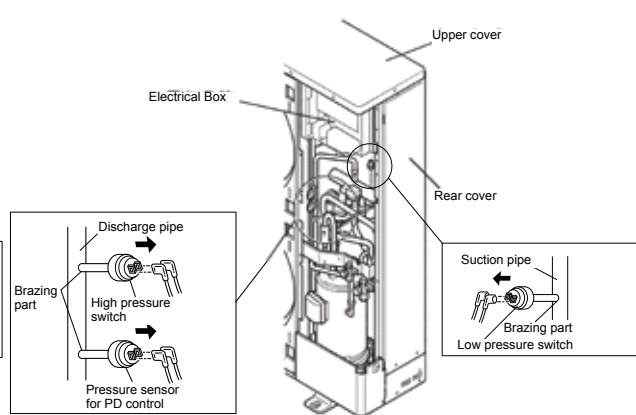

11.5 Noise filter (NF)

11.5.1 Noise filter for 3N~ (400V/50Hz)

The noise filter decreases the leakage of noise made by the inverter to the power supply side. Terminals indicated with "LOAD" are connected to the inverter side and terminals indicated with "LINE" to the power supply side.

Items	Specifications
Model	4LFB-16830-2FA
Rated current	AC415V 27 A
Permissible temperature range	-25 °C to 85 °C
Circuit diagram	

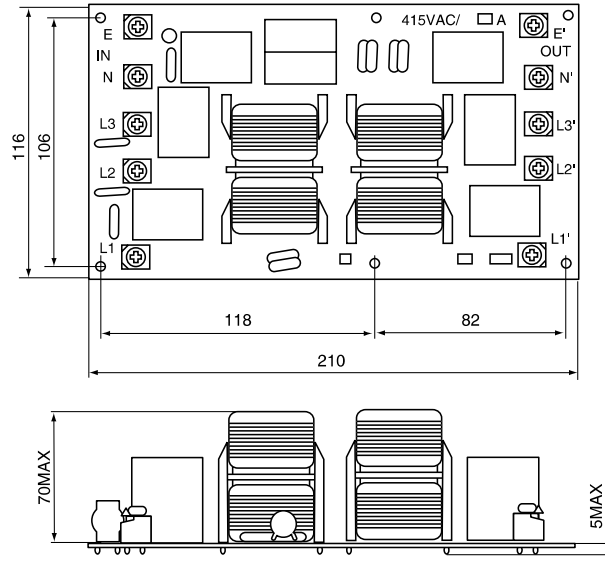

11.5.2 Noise filter for 1~ (230V/50Hz)

The noise filter decreases the leakage of noise made by the inverter to the power supply side. Terminals indicated with "LOAD" are connected to the inverter side and terminals indicated with "LINE" to the power supply side.

Items	Specifications
Model	LFB-14930-3M
Rated current	AC230V 30 A
Permissible temperature range.	-25 °C to 85 °C
Circuit diagram	

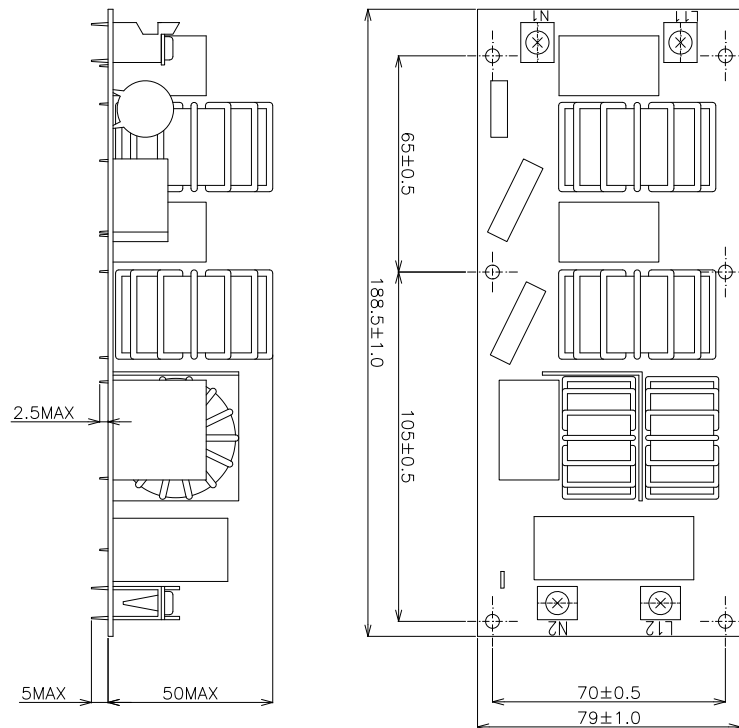

11.6 Capacitor (CB1 CB2)

This part is used for changing the alternative current to the direct current for the inverter. Connect two capacitor in line and used.

Items	Specifications
Models	LNx2G472MSEAH
Capacity of static electricity	4700 μ F
Rated voltage	400 VDC
Permissible temperature range	-25 °C to 95 °C

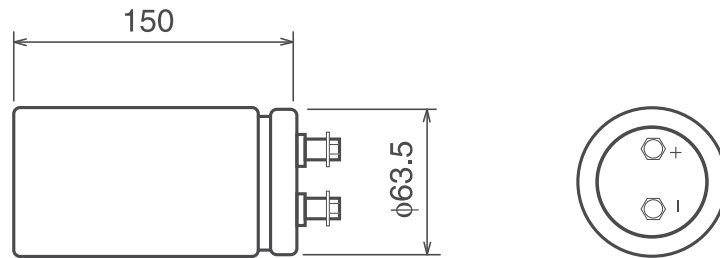

11.7 Reactor (DCL)

11.7.1 Reactor (DCL) for 3N~ (400V/50Hz)

This part is used for changing the alternative current to the direct current for the inverter.

Items	Specifications
Character	1.0 mH+10 (at 1 kHz)
Rated current	30 A
Direct resistance	22.8 mΩ+20 (at 20 °C)
Permissible temperature range	-20 °C to 60 °C

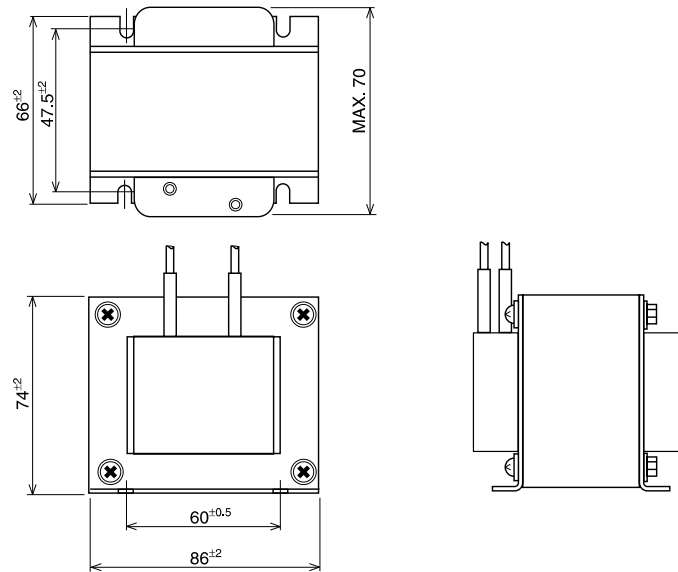

11.7.2 Reactor (DCL) for 1~ (230V/50Hz)

This part is used for changing the alternative current to the direct current for the inverter.

Items	Specifications
Character	0.5 mH±15 (at 1 kHz)
Rated current	30 A
DC Resistance	26 mΩ (at 20 °C)
Permissible temperature range	-20°C to 60°C

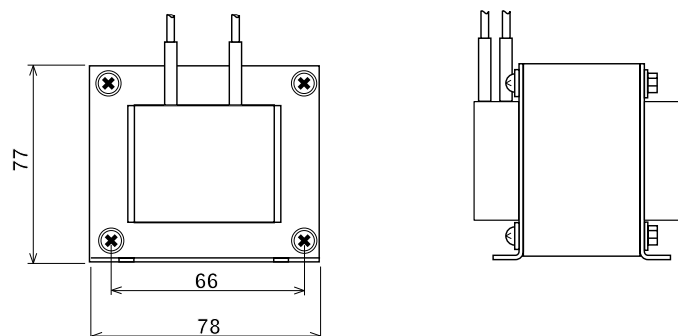

11.8 Scroll compressor

11.8.1 Reliable mechanism for low vibrating and low sound

- 1 The rotating direction is definite.
- 2 The pressure inside of the chamber is high pressure and the surface temperature of the chamber is 60 °C to 110 °C.

11.8.2 Principle of compression

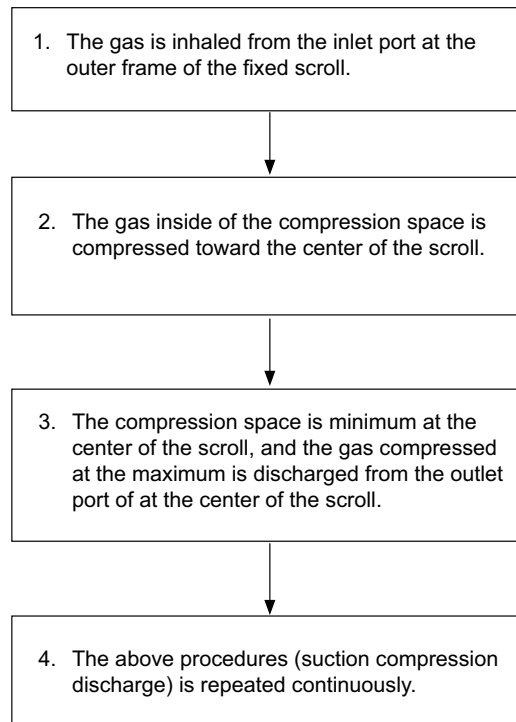

1. Gas.
2. Rotating scroll.
3. Compression space.
4. Fixed scroll
- A. Suction procedure.
- B. Discharge process.
- C. Compression process.

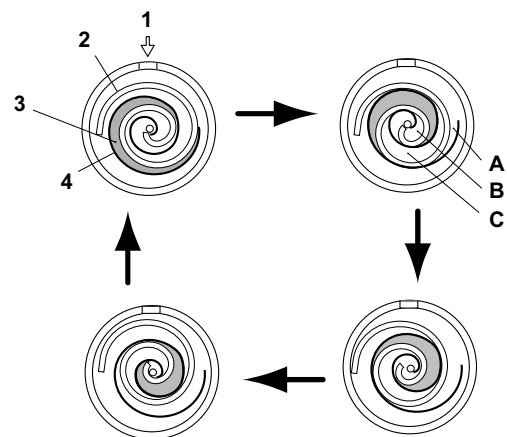

12. Maintenance notes

Index

12.1. General notes.....	456
12.1.1. Checking the power source and the wiring connection.....	456
12.1.2. Burnt-out compressor due to an insufficient refrigerant charge.....	456
12.1.3. Insufficient cooling performance when a long piping is applied.....	457
12.1.4. Abnormally high operation sound (in the ceiling type indoor unit).....	457
12.1.5. Alarm code “31”.....	458
12.1.6. Not cooling well due to insufficient installation space for the outdoor unit.....	458
12.2. Maintenance work.....	459
12.3. Service and maintenance record.....	460
12.4. Service and maintenance record using the 7-segment display.....	461
12.5. Service and maintenance record by remote control switch.....	463
12.6. Pump-down method for replacing the compressor.....	464

12.1 General notes

12.1.1 Checking the power source and the wiring connection

Check the following items in the case of abnormal operation:

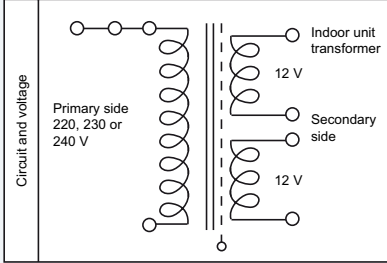
No.	Check item	Procedure
1	Is the breaker of the fuse cut out?	Check the secondary voltage of the breaker and the fuse by means of a tester.
2	Is the secondary power source on the transformer correct?	<p>Disconnect the secondary side of the transformer and check the voltage by means of a tester.</p> 
3	Is the wiring loosened or incorrectly connected?	<p>Check the wiring connection on the PCB.</p> <ul style="list-style-type: none"> • Thermistor connectors • Connector of the remote control cable • Connector of the transformer <p>Each connector in a high-voltage circuit. Check the connectors according to the electrical wiring diagram.</p>

12.1.2 Burnt-out compressor due to an insufficient refrigerant charge

Question and answer for the field work

Example 1: Burnt-out compressor due to an insufficient refrigerant charge	
Phenomenon	After commissioning the alarm code "08" sometimes occurred and the compressors were burnt out after operating for two months.
Cause	<p>The refrigerant piping work was performed during the summer season. The additional refrigerant was not sufficiently charged from the discharge gas side.</p> <p>This insufficient refrigerant charge resulted in the overheating of the discharge gas and the oil deterioration which was finally due to the separated operation despite the alarm code "08".</p>
Countermeasure	<ol style="list-style-type: none"> 1 The compressor was replaced with a new compressor. 2 The correct refrigerant amount was charged according to the refrigerant piping length and the connected indoor units.
Remarks	Additional refrigerant charge: Open the liquid stop valves slightly when you charge the additional refrigerant from the check joint of the liquid stop valves (the discharge gas side) during the cooling process. If the liquid stop valve is fully open it is difficult to charge the additional refrigerant. Do not charge the refrigerant from the gas stop valve.

12.1.3 Insufficient cooling performance when a long piping is applied

Question and answer for the field work

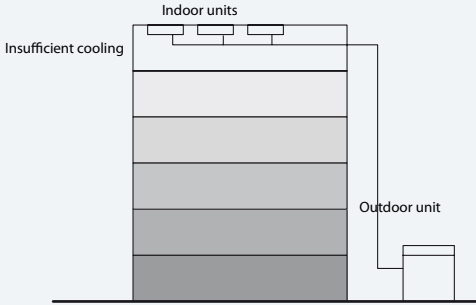
Example 2: Insufficient cooling performance when a long piping is applied	
Phenomenon	Sufficient cooling was not available for an indoor unit that was located at the farthest position.
Cause	<p>If the location of an outdoor unit is 20 meters lower than the location of the indoor units resetting of the DIP switch DSW3 is required. However no setting was performed. Therefore the largest discharge pressure was not increased. This resulted in an insufficient cooling performance for the indoor unit.</p> 
Countermeasure	The setting of the DSW2 was changed.
Remarks	Pay special attention to the size of liquid pipe. Refer to Piping work and refrigerant charge chapter for details.

12.1.4 Abnormally high operation sound (in the ceiling type indoor unit).

Question and answer for the field work

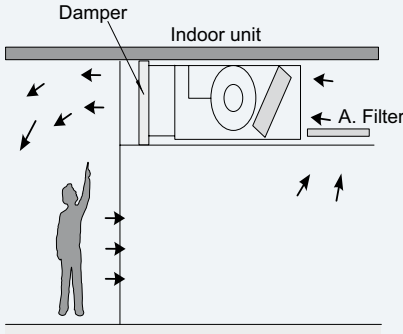
Example 3: Abnormally high operation sound (in-the-ceiling type indoor unit)	
Phenomenon	The operation sound at the "HIGH" speed was abnormally high.
Cause	<p>The indoor units were installed without the ducts. Since there scarcely was any external static pressure an abnormally big air volume was supplied. This resulted in a higher air speed through the heat exchanger.</p> 
Countermeasure	In order to reduce the airflow rate a plate that is used as a damper at the discharge gas side was added.
Remarks	Note that the running current is increased when no external pressure is given to the indoor unit. This results in an over-heating.

12.1.5 Alarm code “31”

Question and answer for the field work

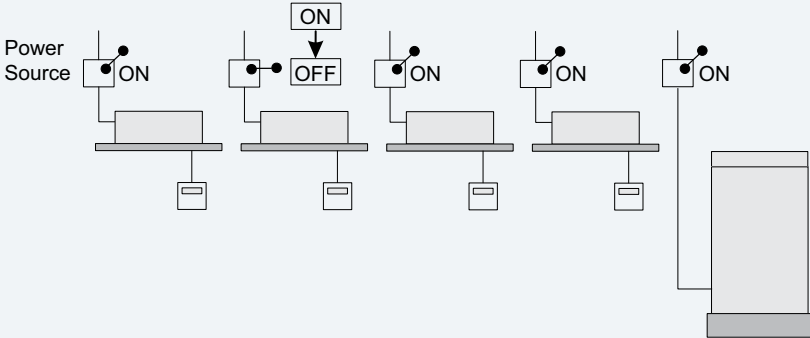
Example 4: Alarm code “31”	
Phenomenon	Alarm code “31” sometimes occurred and the system stopped.
Cause	<p>The combination of the indoor units and the outdoor unit was the following.</p>  <p>This system was used in a tenant building. One of tenant's customers turned off the main switch for the indoor unit while other indoor units are running. This results in a different setting of the total indoor unit capacity in the same refrigerant cycle.</p>
Countermeasure	All the main switches for the indoor units were always ON.

12.1.6 Not cooling well due to insufficient installation space for the outdoor unit

Question and answer for the field work

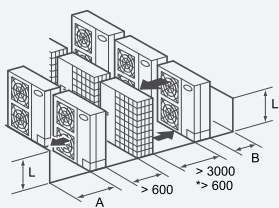
Example 5: Not cooling well due to insufficient installation space for outdoor unit										
Phenomenon	Cooling operation was well performed through the intermediate season. However the cooling operation was not well available when the outdoor temperature was higher than 35 °C.									
Cause	<p>As the outdoor units were installed without a sufficient installation space the hot discharge air from other outdoor units was circulated.</p> <p>In this case though the outdoor temperature was 35 °C the actual suction air temperature was nearly 50 °C and protection system from excessively high suction pressure was activated the frequency of the compressor was decreased and the cooling capacity was also decreased accordingly.</p> <p>As the outdoor units in-line were installed back to back with a distance of 600 mm between each outdoor unit's back the hot discharged air from other outdoor units was circulated.</p>									
Countermeasure	Ensure that sufficient space should be secured for multi-row and multiple-installation.									
Example	<p>Keep a distance of more than 15 mm between other units and do not put obstacles on the right and left sides. Dimension B is as shown below.</p> <p>For detailed information please refer to Unit Installation chapter.</p> <table border="1"> <thead> <tr> <th>L</th> <th>A</th> <th>B</th> </tr> </thead> <tbody> <tr> <td>$0 < L < 1/2H$</td> <td>600 or more</td> <td>300 or more</td> </tr> <tr> <td>$1/2H < L < H$</td> <td>1400 or more</td> <td>350 or more</td> </tr> </tbody> </table> 	L	A	B	$0 < L < 1/2H$	600 or more	300 or more	$1/2H < L < H$	1400 or more	350 or more
L	A	B								
$0 < L < 1/2H$	600 or more	300 or more								
$1/2H < L < H$	1400 or more	350 or more								



NOTE

- If L is larger than H mount the units on a base so that H is greater or equal to L .
- In this situation ensure that the base is closed and does not allow the airflow to short circuit.
- When the mark * dimension is secured be sure to mount the airflow guide.

12.2 Maintenance work

For the indoor unit and the outdoor unit

- 1 Fan and fan motor
 - Lubrication: All the fan motors are pre-lubricated and sealed at the factory. Therefore no lubrication maintenance is required.
 - Sound and vibration: Check for abnormal sounds and vibrations.
 - Rotation: Check the clockwise rotation and the rotating speed.
 - Insulation: Check the electrical insulation resistance.
- 2 Heat exchanger
 - Clog: Inspect the heat exchanger at regular intervals and remove any accumulated dirt and any accumulated dust from the heat exchanger. You should also remove from the outdoor units other obstacles such as the growing grass and the pieces of paper which might restrict the airflow.
- 3 Piping connection
 - Leakage: Check for the refrigerant leakage at the piping connection.
- 4 Cabinet
 - Stain and lubrication: Check for any stain and any lubrication. Remove the stain and the lubrication.
 - Fixing screw: Check for any loosened screw or any lost screw. Fix the loosened screws and the lost screws. Insulation material: Check for any peeled thermal insulator on the cabinet. Repair the thermal insulator.
- 5 Electrical equipment
 - Activation: Check for an abnormal activation of the magnetic contactor the auxiliary relay the PCB and others.
 - Line condition: Pay attention to the working voltage the working amperage and the working phase balance. Check for any faulty contact that is caused by the loosened terminal connections the oxidized contacts the foreign matter and other items. Check the electrical insulation resistance.
- 6 Control device and protection device
 - Setting: Do not readjust the setting in the field unless the setting is maintained at a point that is different from the point listed in the section

For the outdoor unit

- 1 Compressor
 - Sound and vibration: Check for abnormal sounds and vibrations.
 - Activation: Check that the voltage drop of the power supply line is within 15 at the start and within 2 during the operation.
- 2 Reverse valve
 - Activation: Check for any abnormal activation sound.
- 3 Strainer
 - Clog: Check that there is no temperature difference between both ends.
- 4 Ground wire
 - Ground line: Check for the continuity to earth.
- 5 Oil heater
 - Activation: You should activate the oil heater at least twelve hours before the start-up by turning ON the main switch.

12.3 Service and maintenance record

No.	Check item	Action	Judgement	
1	Is the service area sufficient?	—	Yes	No
2	Is there a short circuit of the discharged air?	—	Yes	No
3	Any heat influence?	—	Yes	No
4	Is the ground wire connected?	—	Yes	No
5	Refrigerant piping.	—	Good	Not Good
6	Fixing the units.	—	Good	Not Good
7	Is there any damage on the outer surface or the internal surface?	—	Yes	No
8	Checking the screw and the bolts.	Tighten if loosened.	Tightened	Not Tightened
9	Tightening the terminal screws.	Tighten all the terminal screws with a Phillips screwdriver.	Tightened	Not Tightened
10	Are the compressor terminals tightly fixed?	Push all the terminals.	Pushed	Not Pushed
11	Insulation resistance.	Measure the insulation resistance with an insulation resistance meter. Comp. and fan. Motor: greater than 3MΩ. Others: greater than 3MΩ.	Good	Not Good
12	Does the drain water flow smoothly?	Check the smooth flow by pouring some water.	Good	Not Good
13	Check for a leakage in the compressor.	Check for any leakage.	Good	Not Good
14	Check for a leakage in the outdoor heat exchanger.	ditto	Good	Not Good
15	Check for a leakage in the indoor heat exchanger.	ditto	Good	Not Good
16	Check for a leakage in the 4-way valve.	ditto	Good	Not Good
17	Check for a leakage in the check valve.	ditto	Good	No Good
18	Check for a leakage in the accumulator.	ditto	Good	Not Good
19	Check for a leakage in the strainer.	ditto	Good	Not Good
20	Check for a leakage in the electronic expansion valve	ditto	Good	Not Good
21	Check for a leakage in the piping.	ditto	Good	Not Good
22	Check the direction of the fans.	By viewing the airflow volume.	Good	Not Good
23	Voltage among each phase.	Higher than AC220V.	Good	Not Good
24	Vibration and sound.	Check the fan the compressor the piping and others.	Good	Not Good
25	Activation of each operation mode.	Check the activation of the COOL switch the HEAT switch the STOP switch and the TEMP switch.	Good	Not Good
26	High-pressure cut-out switch.	Check the actual activation value.	Good	Not Good
27	Check the activation of the drain-up mechanism.	Check the activation during the cooling process.	Good	Not Good
28	Air inlet temperature of the indoor unit DB/WB.	—	(°C)DB	(°C)WB
29	Air outlet temperature of the indoor unit DB/WB.	—	(°C)DB	(°C)WB
30	Air inlet temperature of the outdoor unit DB/WB.	—	(°C)DB	(°C)WB
31	Air outlet temperature of the outdoor unit DB/WB.	—	(°C)DB	(°C)WB
32	High-pressure switch.	—	kg/cm ² G	
33	Low-pressure switch.	—	kg/cm ² G	
34	Operating voltage.	—	V	
35	Operating current.	—	A	
36	Instructions to the client for cleaning the air filter.	—	Done	Not yet
37	Instructions to the client about the cleaning method.	—	Done	Not yet
38	Instructions to the client about the operation.	—	Done	Not yet

12.4 Service and maintenance record using the 7-segment display

Customer's name: _____		Date: _____								
Outdoor unit model (serial No.)		RAS- (Serial No.)				RAS- (Serial No.)				
1. Operation mode										
2. Test run start time										
3. Data collect start time										
4. Read out data from 7-segment in outdoor unit										
4.1 Protection control code										
4.2 Total capacity of I.U connected		CP								
4.3 Input/output state of outdoor micro-computer		SC	52C	FAN1	FAN2	20A	52C	FAN1	FAN2	20A
			20F	21	CH	PSH	20F	21	CH	PSH
4.4 Alarm code for abnormal stoppage of compressor		AC								
4.5 Inverter order frequency to compressor		H1								
4.6 Indoor order frequency to compressor		H2								
4.7 Air flow ratio		Fo								
4.8 O.U. expansion valve opening		Eo								
4.9 Temp. at the top of compressor		Td								
4.10 Evaporating temp. at heating		TE								
4.11 Ambient air temp.		To								
4.12 Cause of stoppage at inverter		iT								
4.13 Inverter secondary current		A2								
4.14 Inverter fin temperature		TF								
4.15 O.U. address		nA								
5. Indoor unit (unit No. 1)										
5.1 I.U. expansion valve opening		EA								
5.2 Liquid pipe temp. of I.U. (Freeze protection)		LA								
5.3 I.U. intake air temp.		iA								
5.4 I.U. discharge air temp.		oA								
5.5 Cause of I.U. stoppage		dA								
6. Indoor unit (unit No. 2)										
6.1 I.U. expansion valve opening		EA								
6.2 Liquid pipe temp of I.U. (Freeze protection)		LA								
6.3 I.U. intake air temp.		iA								
6.4 I.U. discharge air temp.		oA								
6.5 Cause of I.U. stoppage		dA								
7. Indoor unit (unit No. 3)										
7.1 I.U. expansion valve opening		EA								
7.2 Liquid pipe temp. of I.U. (Freeze protection)		LA								
7.3 I.U. intake air temp.		iA								
7.4 I.U. discharge air temp.		oA								
7.5 Cause of I.U. stoppage		dA								
8. Indoor unit (unit No. 4)										
8.1 I.U. expansion valve opening		EA								

Customer's name: _____		Date: _____
Outdoor unit model (serial No.)	RAS- (Serial No.)	RAS- (Serial No.)
8.2 Liquid pipe temp. of I.U. (Freeze protection)	LA	
8.3 I.U. intake air temp.	iA	
8.4 I.U. discharge air temp.	oA	
8.5 Cause of I.U. stoppage	dA	

NOTE

- ***O.U.:* Outdoor Unit.**
- ***I.U.:* Indoor unit.**
- ***FAN1 FAN2:* Constant speed fan.**
- ***52C:* CMC.**
- ***PSH:* High pressure switch.**
- ***20A:* Solenoid valve (SVA).**
- ***20F:* Solenoid valve (SFV).**
- ***21:* Reversing valve (RVR).**
- ***CH:* Oil heater.**
- ****: Multiply 1/8 by the code on the 7-segment.***

12.5 Service and maintenance record by remote control switch

Data sheet for checking by remote control switch

Time	:	:	:	:	:	:
I.U. modelo						
I.U. serial No.						
I.U. No. / alarm code						
	Check mode 1	Check mode 2	1-2	1-2	1-2	1-2
B Temp. indication						
Set temp.	b1	--				
Inlet air temp.	b2	91				
Discharge air temp.	b3	92				
Liquid pipe temp.	b4	93				
Remote thermistor temp.	b5	--				
Outdoor air temp.	b6	94				
Gas pipe temp.	b7	95				
Evaporating temp. at heating	b8	96				
Control information	b9	97				
Comp. top temp.	bA	98				
Thermo temp. of remote control switch	bb	--				
C Micro-computer state indication						
I.U. micro-computer	C1	--				
O.U. micro-computer	C2	--				
D Stopping cause state indication						
Stopping cause state indication	d1	--				
E Alarm occurrence						
Times of abnormality	E1	--				
Times of power failure	E2	--				
Times of abnormal transmitting	E3	--				
Times of inverter tripping	E4	--				
F Automatic louver state						
Louver sensor state	F1	--				
H Pressure frequency state indication						
Discharge pressure	H1	99				
Suction pressure	H2	9A				
Control information	H3	9b				
Operating frequency	H4	9C				
J I.U. capacity Indication						
I.U. capacity (1/8HP)	J1	--				
O.U. code	J2	--				
Refrigerant cycle number	J3	--				
Refrigerant cycle number	J4	--				
L Opening of ex. valve						
I.U. ex. valve	L1	9d				
O.U. ex. valve 1	L2	9E				
O.U. ex. valve 2	L3	--				
O.U. ex. valve B	L4	--				
P Running current indication (reference)						
Comp. current	P1	9F				

12.6 Pump-down method for replacing the compressor

No.	Procedure	Remarks
1	Turn off the main switch of the outdoor unit.	
2	Remove the covers the thermistor the crankcase heater the power wirings and other items according to the chapter 10.	Make sure that the terminal part of the detached power supply wires is not exposed by the winding insulation tape and other items.
3	Attach the manifold to the check joint of the high pressure side and the low-pressure side of the outdoor unit.	—
4	Turn on the main switch of the outdoor unit.	—
5	Set the exclusion of the compressor by setting the DSW so that a broken compressor will not work. You can set the exclusion of the compressor by setting the DSW1-4 in ON position.	—
6	The compressor replacing mode is performed: <ul style="list-style-type: none"> The DSW1-4 on the outdoor unit PCB→ON (The cooling is run). 	<ul style="list-style-type: none"> This operation is performed for up to a maximum of ten minutes. If the inverter compressor is excluded the operation starts after three minutes.
7	The operation finishes when one of the following conditions occurs: <ol style="list-style-type: none"> Ten minutes have passed and STP is displayed in seven segments. "08" is displayed in seven segments. When $P_s < 0.1$ MPa is continued for one minute in ten minutes STP is displayed in seven seconds and the operation finishes. 	<ul style="list-style-type: none"> The operation may finished when any of the conditions 1) to 3) occurs.
8	Close the liquid stop valve completely.	To avoid the spillage of all the refrigerant if the check valve is broken.
9	Check for a leakage of the check valve on the discharge gas side: <ul style="list-style-type: none"> DSW4-4 (enforced stoppage of the compressor) → ON so that the compressor will not run although the running command is sent from the remote control switch. Check that variation of P_s on the outdoor unit PCB is 17 seconds. Make sure that the P_s increase is within 0.03 Mpa in two minutes after the P_s increase at the stoppage (during approximately five minutes). Also make sure that $P_d > P_s$. 	<ul style="list-style-type: none"> When you stop the compressor for replacing: You can check the leakage of the check valve by means of the P_s variation because the SVA opens so that the discharge gas side of the inverter compressor can connect to the low-pressure side. 0.03 MPa/2 minutes is within the permissible limits for the check valve on the discharge gas side. The leakage of the check valve may cause an incorrect brazing due to the gas pressure at the brazing of the discharge piping. If the compressor-replacing mode is performed again set the DSW4-4 to OFF and keep the DSW4-4 at the OFF side during ten minutes. Then start according to the procedure No. 6.
10	Collect the refrigerant by means of the refrigerant collection: <ul style="list-style-type: none"> Perform either A or B depending on the process 10. <ul style="list-style-type: none"> The leak rate at the process 10 is within the specification → Collect the refrigerant only at the low-pressure side. The leak rate at the process 10 is greater than the specification → Collect all the refrigerant of the outdoor unit side by means of the machine. 	<ul style="list-style-type: none"> The discharge of the refrigerant in the atmosphere is strictly forbidden. Make sure that the refrigerant is collected by the collector. Keep a note of the quantity of the collected refrigerant.
11	After collecting the refrigerant remove the change hose (collector side) of the low-pressure side so that the low-pressure side of the refrigerant cycle will be the atmosphere pressure.	<ul style="list-style-type: none"> Make sure that there is no pressure increase of the low-pressure sides after collecting the refrigerant. Make sure that the refrigerant cycle is the atmosphere pressure. Otherwise problems such as the blowing of gas and the suction of the cutting material) may occur when you are removing the compressors.
12	Turn OFF the main switch of the outdoor unit.	—
13	Perform the replacement of the compressor and the change of the refrigerant oil according to the section "replacing the compressor".	Make sure that you follow the instructions.
14	Perform the vacuum from the check joint of the low-pressure side.	If you collect the refrigerant only on the low-pressure side (A in 11). You cannot perform the vacuum of the refrigerant from the check joint of the high-pressure side.
15	Open the liquid stop valve and the gas stop valve completely when you finish the vacuum.	—
16	Make sure that the power is turned OFF and attach the following items: the power supply wire the thermistor the crankcase heater the 63H wiring the panel and the nut).	—
17	Set the DSW back to the original setting. Make sure that all the wirings to the compressor are connected correctly.	—
18	Recharge the refrigerant that is collected in the process by the stop valve of the liquid side during the cooling at the TEST RUN mode.	If the replacement of the compressor takes more than two hours an additional change of the refrigerant is necessary. Additional change = (replacing time – 2 hours) x 0.5 kg.

Hitachi Air Conditioning Products Europe, S.A.
Ronda Shimizu, 1 - Polig. Ind. Can Torrella
08233 Vacarisses (Barcelona) Spain



Hitachi certifies that our products have met EU consumer safety, health and environmental requirements.



Hitachi Air Conditioning Products Europe, S.A. is certified with:
ISO 9001 of AENOR, Spain for its Quality Management accordance with the standard
ISO 14001 of AENOR Spain for its Environmental Management systems accordance with the standard



Hitachi air conditioning products are manufactured according to:
ISO 9001 of JQA, Japan for its Quality Management accordance with the standard
ISO 14001 of JACO, Japan for its Environmental Management accordance with the standard



HITACHI participates in the Eurovent Certification Programme; the certified data of certified models are listed in the Eurovent Certification Online Directory (www.eurovent-certification.com).