

WR 200 / 250/ 325 - 5 AM. E..

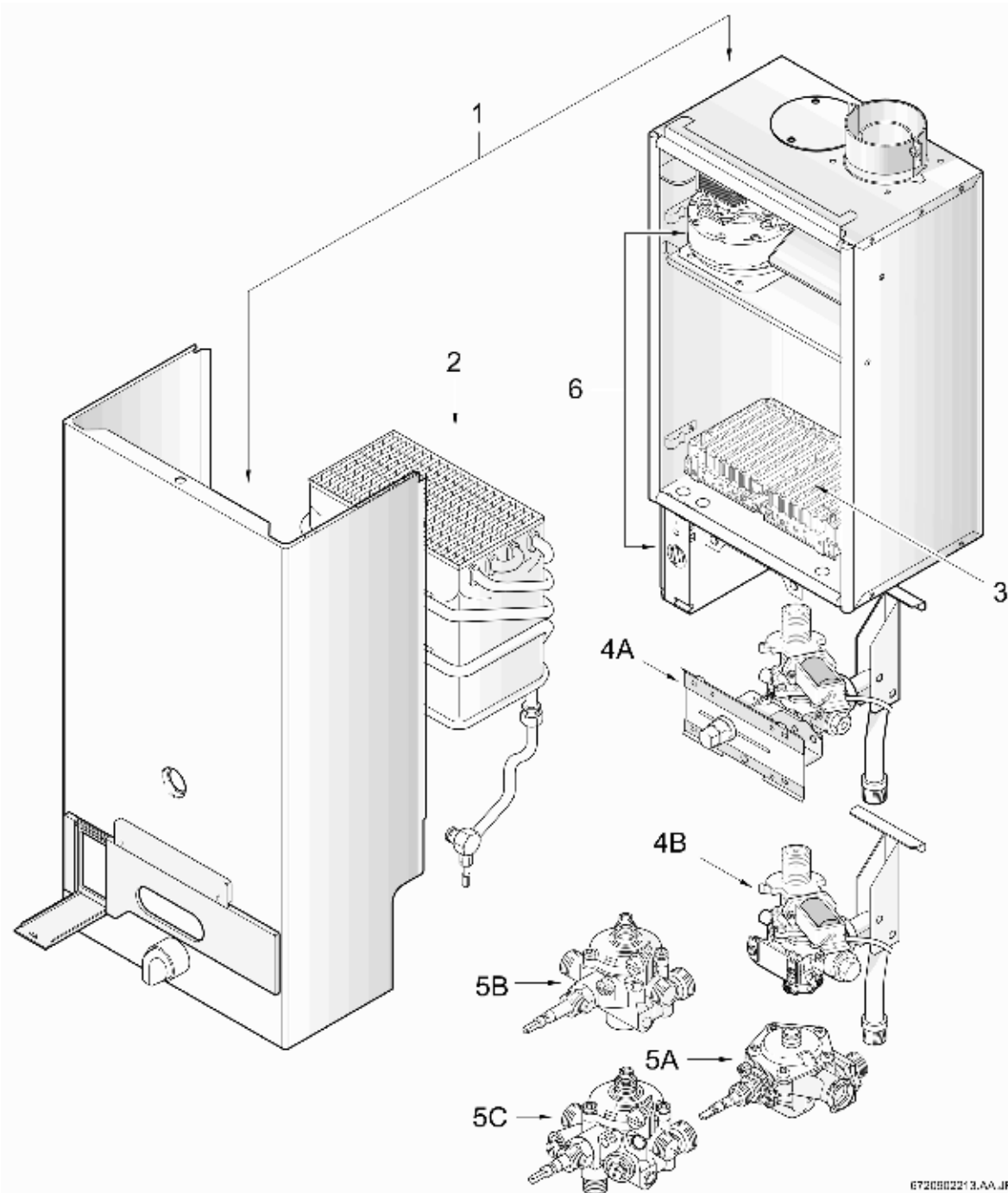

BOSCH

JUNKERS

Vulcano

[de] Wichtige Hinweise zur Installation/Montage

Die Installation/Montage muss durch eine für die Arbeiten zugelassene Fachkraft unter Beachtung der geltenden Vorschriften erfolgen.

[en] Important notes on installation/assembly

The installation/assembly must be carried out by a professional who is authorised to do the work, and with due regard to the relevant regulations.

[fr] Instructions importantes pour l'installation/le montage

L'installation/le montage doit être effectué(e) par un spécialiste qualifié pour les opérations concernées et dans le respect des prescriptions applicables.

[bg] Важни указания във връзка с инсталацията/монтажа

Инсталацията/монтажът трябва да се извършва от лицензиран за работите специалист в съответствие с приложимите разпоредби.

[cs] Důležité pokyny k instalaci/montáži

Instalaci/montáž musí při dodržení platných předpisů provést odborný pracovník s příslušným oprávněním pro tyto práce.

[da] Vigtige anvisninger til installationen/monteringen

Installationen/monteringen skal foretages af en godkendt installatør under overholdelse af de gældende forskrifter.

[el] Σημαντικές υποδείξεις για την εγκατάσταση/συναρμολόγηση

Η εγκατάσταση/συναρμολόγηση πρέπει να πραγματοποιείται από εξουσιοδοτημένο για τις εργασίες αυτές τεχνικό προσωπικό, το οποίο θα πρέπει να φροντίζει ώστε να τηρούνται οι ισχύουσες διατάξεις.

[es] Indicaciones importantes para instalación/montaje

La instalación/el montaje lo debe realizar personal especializado autorizado para los trabajos, respetando las prescripciones vigentes.

[et] Olulised juhised paigaldamiseks/montaažiks

Paigaldamist/montaaži tohib läbi viia selleks volitusi omav spetsialist, arvestades kehtivaid nõudeid.

[fi] Belangrijke aanwijzingen betreffende de installatie/montage

De installatie/montage moet worden uitgevoerd door een voor de werkzaamheden geautoriseerde installateur. Hij moet rekening houden met de geldende voorschriften.

[fi] Tärkeitä asennus- ja kokoonpano-ohjeita

Näihin töihin hyväksytyn ammattiasentajan pitää suorittaa asennus- ja kokoonpanotyöt voimassa olevien määräysten mukaisesti.

[hu] Fontos tudnivalók az installálás/szereléshez

Az installálás/szerelést egy, a munkákra felhatalmazott szakembernek kell végeznie, az érvényes előírások figyelembevételével.

[it] Avvertenze importanti per l'installazione/il montaggio

L'installazione/il montaggio deve aver luogo ad opera di una ditta specializzata ed autorizzata in osservanza delle disposizioni vigenti.

[he] משיגנעלוגאני מיתותעגעיניס ונסטלאגיאניס/מאנטאגיאניס/מאנטאגיאניס

אנטלאגיאניס/מאנטאגיאניס ונדא גאנאורגיאניסלדעס סאמאנטאגיאניס דאזעבעולע קלאסיפיקאטארי פערסאנאלס מיער, מוקמעדי גאנאנעסלס דאגעצוי.

[lt] Svarbios instaliavimo ir (arba) montavimo nuorodos

Instaliuoti ir montuoti, laikantis galiojančių taisyklių, leidžiama kvalifikuotiems specialistams, kurie buvo įgalioti šiems darbams atlikti.

[lv] Svarīgi norādījumi par iekārtas uzstādīšanu / montāžu

Iekārtas uzstādīšanu/montāžu ir jāveic specializētam sertificētam speciālistam, ievērojot spēkā esošos noteikumus.

[nl] Belangrijke aanwijzingen betreffende de installatie/montage

De installatie/montage moet worden uitgevoerd door een voor de werkzaamheden geautoriseerde installateur rekening houdend met de geldende voorschriften.

[no] Viktig informasjon om installasjon/montering

Installasjonen/monteringen skal gjennomføres av autoriserte installatører, og gjeldende forskrifter skal følges.

[pl] Ważne wskazówki dotyczące instalacji/montażu

Instalacja/montaż muszą być wykonane przez uprawnionego do tego rodzaju prac specjalistę przy zachowaniu obowiązujących przepisów.

[pt] Indicações importantes relativas à instalação/montagem

A instalação/montagem deve ser efetuada por um técnico especializado com qualificações para estes trabalhos, tendo em atenção os regulamentos em vigor.

[ro] Indicații importante privind instalarea/montajul

Instalarea/montajul trebuie realizate de către un specialist autorizat pentru lucrările respective, respectându-se prescripțiile valabile.

[ru] Важные указания по подключению/монтажу

Подключение/монтаж должны выполнять специалисты, имеющие допуск к выполнению таких работ, при соблюдении действующих норм и правил.

[sk] Dôležité pokyny týkajúce sa inštalácie/montáže

Inštaláciu/montáž musí realizovať odborník s oprávnením na výkon týchto prác, pričom musí dodržiavať platné predpisy.

[sl] Pomembni napotki za namestitvev/montažo

Namestitvev/montažo mora izvesti strokovnjak, pristojen za tovrstna dela, ob upošte vanju veljavnih predpisov.

[sr] Važna uputstva za ugradnju i montažu

Ugradnju i montažu moraju da obave samo stručna lica ovlašćena za izvođenje takvih radova koja će poštovati važeće propise.

[sv] Viktiga anvisningar för installation/montering

Installationen/monteringen måste utföras av en behörig och fackkunnig person enligt gällande föreskrifter.

[tr] Kurulum/Montaj ile ilgili önemli uyarılar

Kurulum/Montaj çalışmaları sadece yetkili bayiler tarafından aşağıda belirtilen talimatlar dikkate alınarak yapılmalıdır.

[uk] Важливі вказівки щодо установки/монтажу

Установку/монтаж мають здійснювати фахівці, що мають дозвіл на проведення цих робіт, із дотримання чинних приписів.

[zh] 安裝方面的重要提示

必須由受到許可承擔該項工作的專業人員遵照相關法規進行安裝。

[ar] ملاحظات هامة للتركيب/التجميع

يجب أن يتم التركيب/التجميع من قبل متخصص مصرح له بالعمل، مع مراعاة اللوائح السارية.

[fa] تذکرات مهم درباره نصب/مونتاژ

نصب/مونتاژ باید توسط فردی حرفه ای که مجاز به انجام این کار است، و همچنین با توجه کامل به مقررات مربوطه انجام شود.

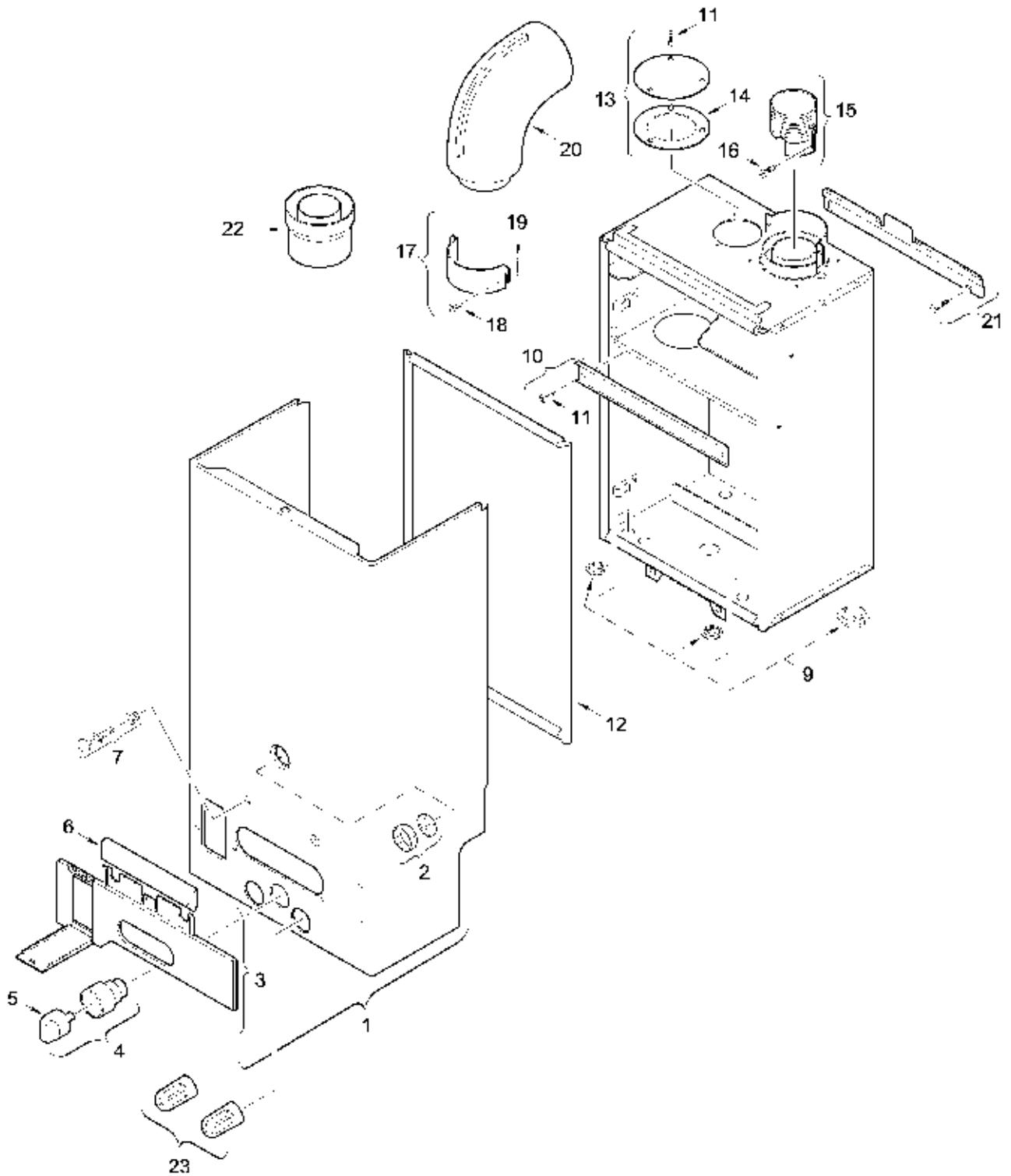

6r20902214.AA.JI

1

Frente
Front cover
Mantel
Habillage
Mantello
Carcasa

WR 200 / 250/ 325 - 5 AM. E..

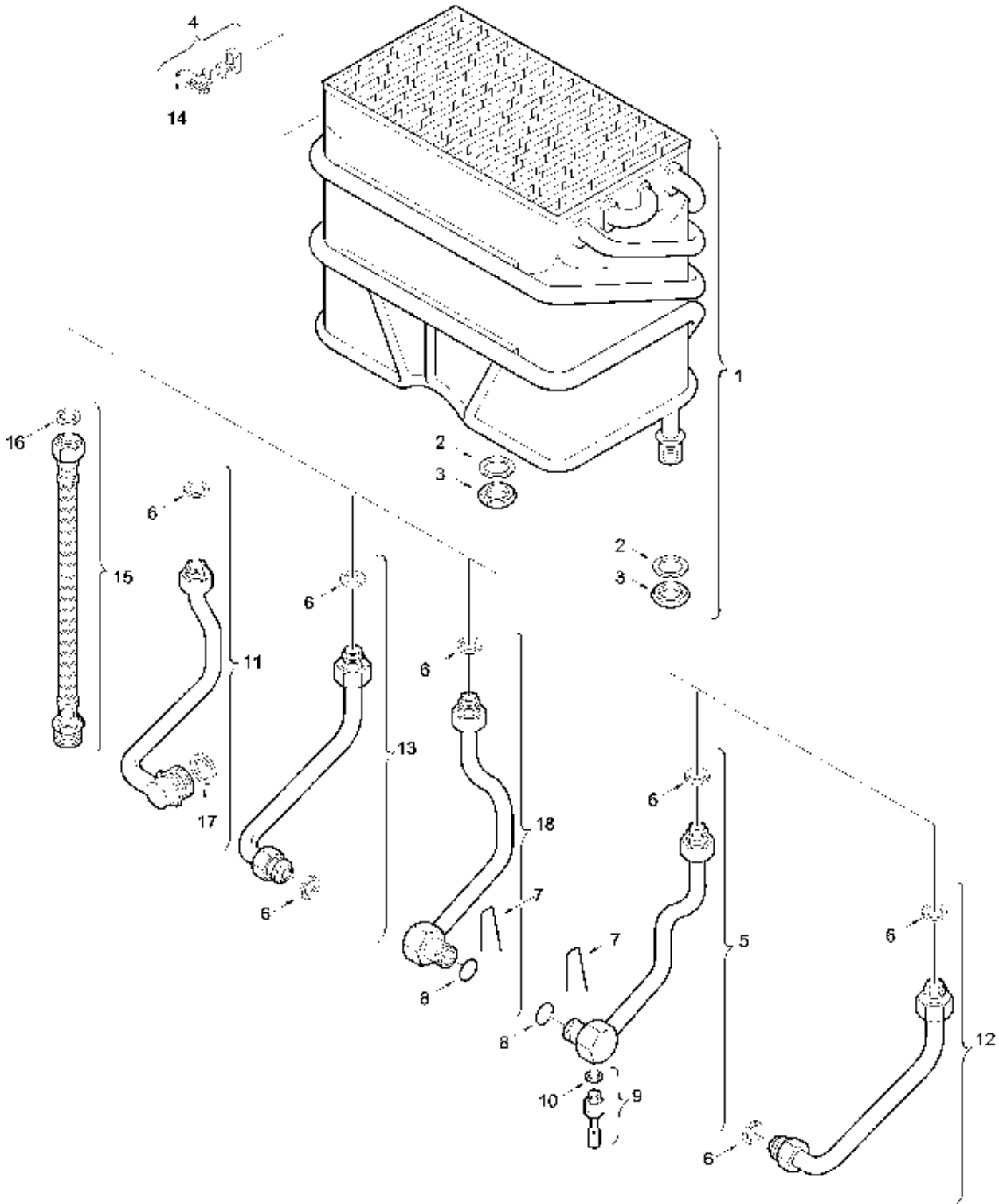

6720602215.AA.JF

2

Câmara de combustão
Heating body
Innenkörper
Corps intérieur
Corpo interno
Cuerpo de caldeo

WR 200 / 250/ 325 - 5 AM. E..

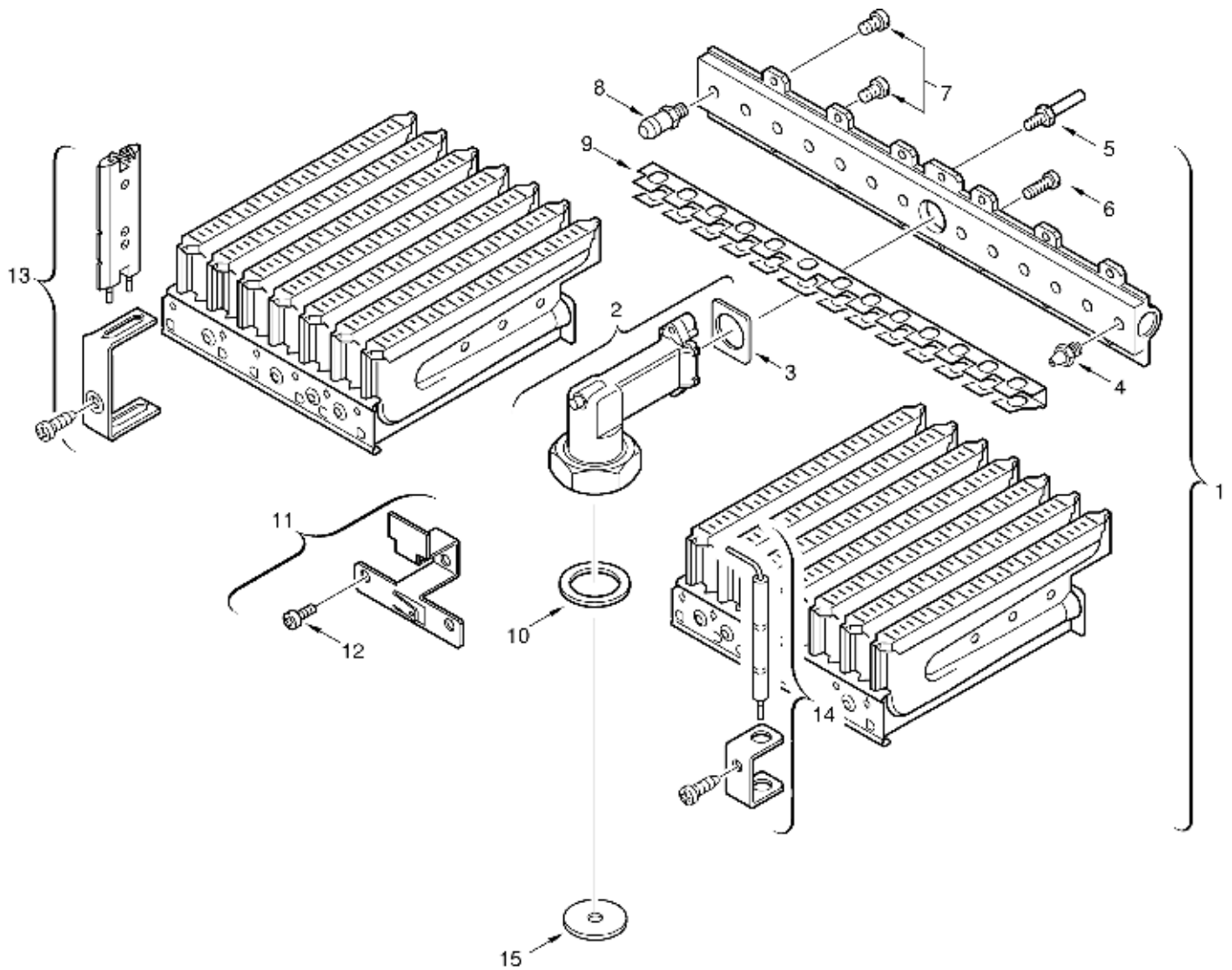

6720902216.AA.JF

3

Queimador
Burner
Brenner
Brûleur
Bruciatore
Quemador

WR 200 / 250/ 325 - 5 AM. E..

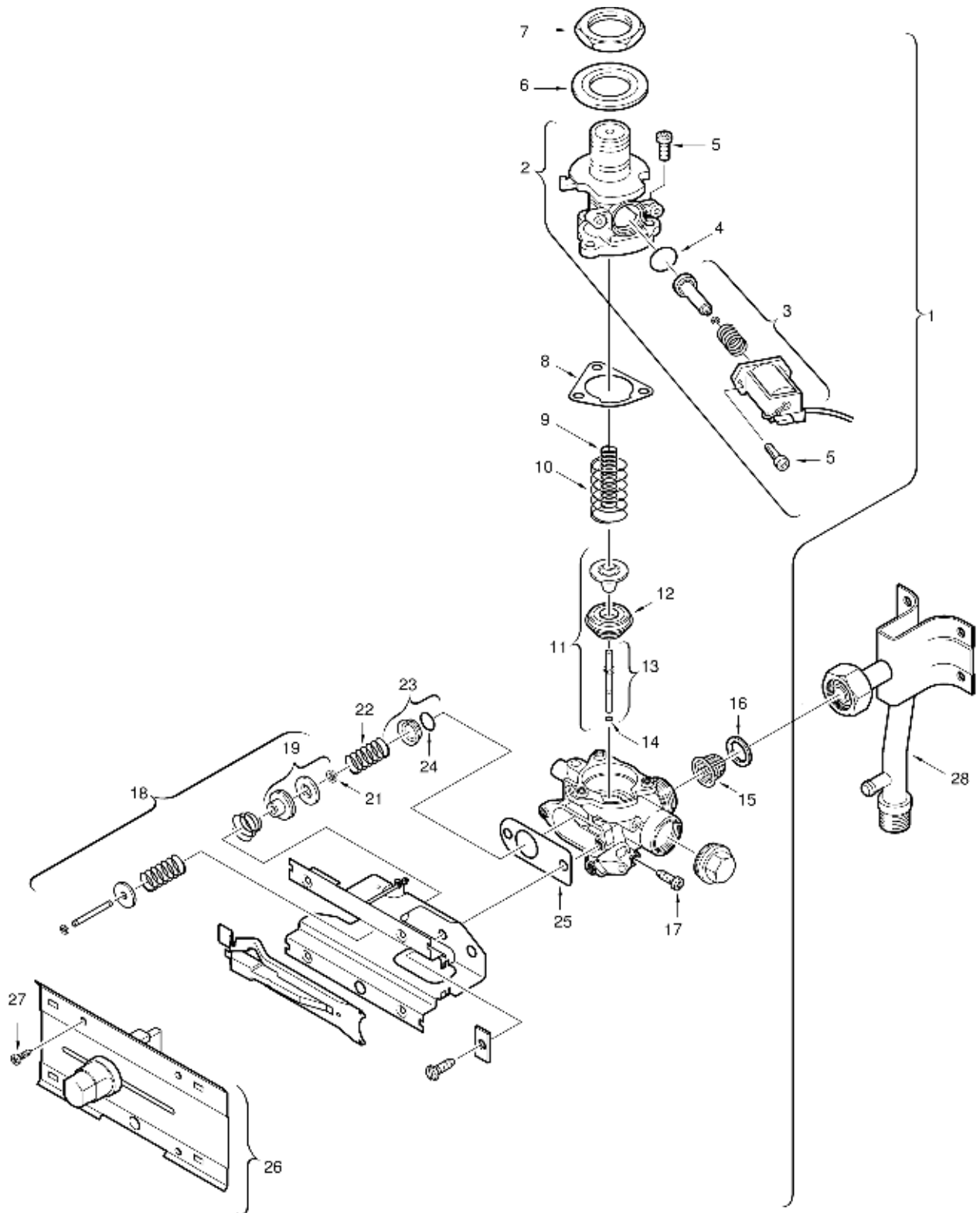

6720802217 AA.JF

4 Automático de gás
Gas valve
Gasarmatur
A Bloc gaz
Gruppo gas
Cuerpo de gas

WR 200 / 250/ 325 - 5 AM. E..

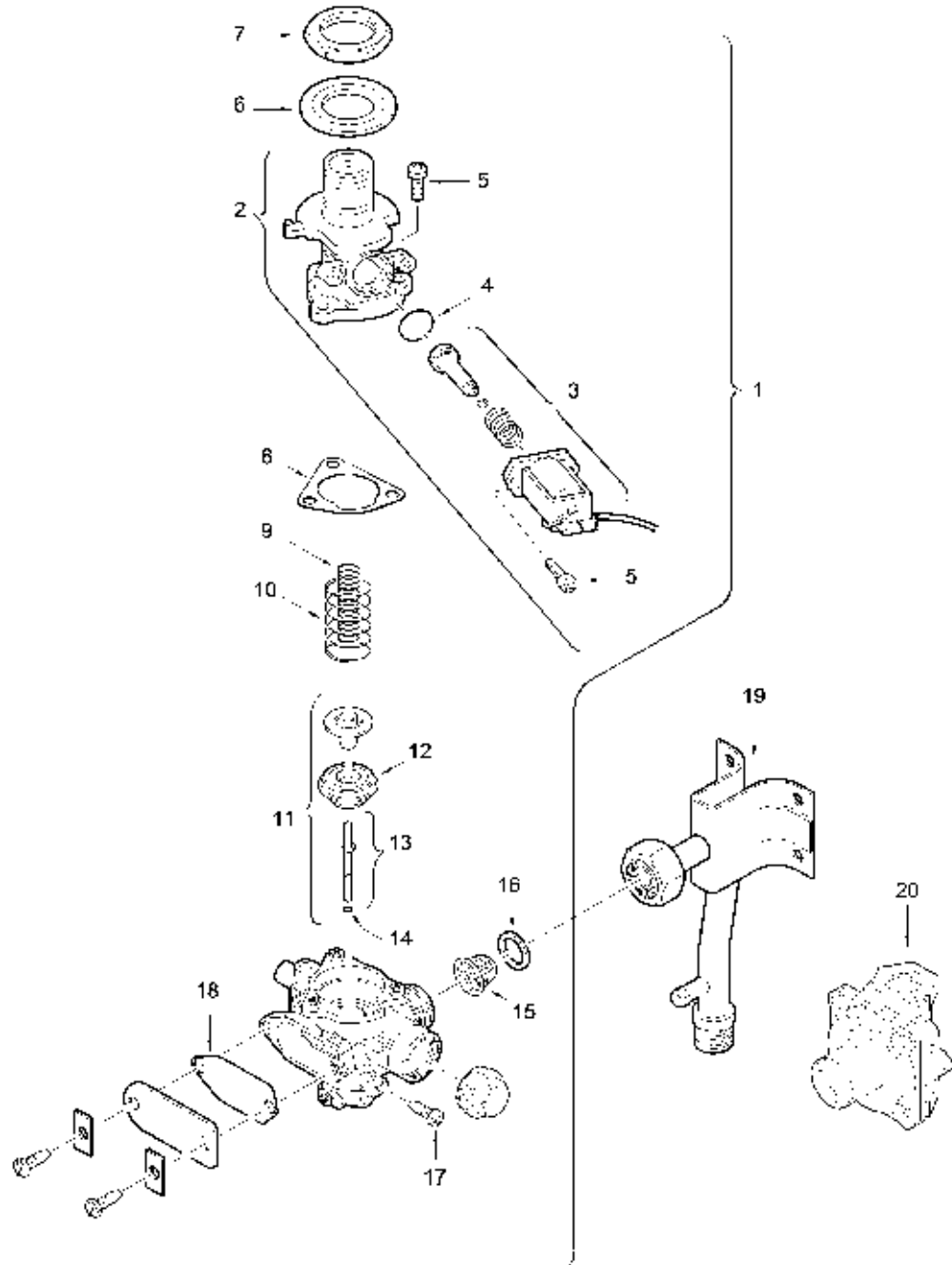

67200022 13 AA JF

4
B

Automático de gás
Gas valve
Gasarmatur
Bloc gaz
Gruppo gas
Cuerpo de gas

WR 200 / 250/ 325 - 5 AM. E..

Pos	Designação Description Bezeichnung Dénomination Descrizioni Descripción	S-Nr	N° de pedido Ordering no. Bestell-Nr. Numéro de commande N° d'ordine Número el ordenar	PG	Tipo gas Gas type Gasart Type gaz Tipo gas Tipo gas	WR200-5AM.E.	WR250-5AM.E.	WR325-5AM.E.													Observações Remarks Bemerkungen Remarques Osservazioni Observaciones
1	Automático de gás		8 707 011 771 0	48	23	■	■	■													
1	Automático de gás	0506,2205,3505, 3506,3605,4305	8 707 011 773 0	48	31,32		■	■													
2	Electroválvula completa		8 708 504 053 0	42		■	■	■													
3	Electroválvula		8 707 201 026 0	40		■	■	■													
4	O-ring (10x)		8 700 205 105 0	20		■	■	■													
5	Parafuso (10x)		8 743 401 002 0	12		■	■	■													
6	Anilha		8 700 103 168 0	14		■	■	■													
7	Porca de aperto		8 703 300 023 0	12		■	■	■													
8	Vedante (10x)		8 701 004 001 0	16		■	■	■													
9	Mola		8 704 603 067 0	12		■	■	■													
10	Mola		8 704 603 118 0	11		■	■	■													
11	Válvula de gás (2E)		8 708 500 309 0	30	23	■	■	■													
11	Válvula de gás (3E)		8 708 500 310 0	30	31,32		■	■													
12	Conjunto de válvula (2)		8 708 500 247 0	22	23	■	■	■													
12	Conjunto de válvula (3)		8 708 500 249 0	22	31,32		■	■													
13	Perno		8 703 101 057 0	13		■	■	■													
14	O-ring (10x)		8 740 205 002 0	17		■	■	■													
15	Filtro de gás em rede (10x)		8 700 507 002 0	15		■	■	■													
16	Anel de vedação (10x)		8 700 103 014 0	12		■	■	■													
17	Parafuso (10x)		8 703 401 051 0	12		■	■	■													
18	Vedante (10x)		8 701 004 020 0	12		■	■	■													
19	Tubo condutor de gás	0700,3505,3506, 3605,4305	8 700 705 422 0	32	23,31	■	■	■													
19	Tubo condutor de gás	3505,3506,5705	8 700 705 438 0	31	23		■	■													
19	TUBO CONDUTOR DE GÁS C/SUP.	2205	8 700 715 081 0	28	23			■													
20	Regulador de pressão	2205	8 707 406 027 0	45	23			■													
20	Regulador de pressão	2205	8 707 406 028 0	46	32			■													

WR 200 / 250/ 325 - 5 AM. E..

Automático de gás
Gas valve
Gasarmatur
Bloc gaz
Gruppo gas
Cuerpo de gas

4B

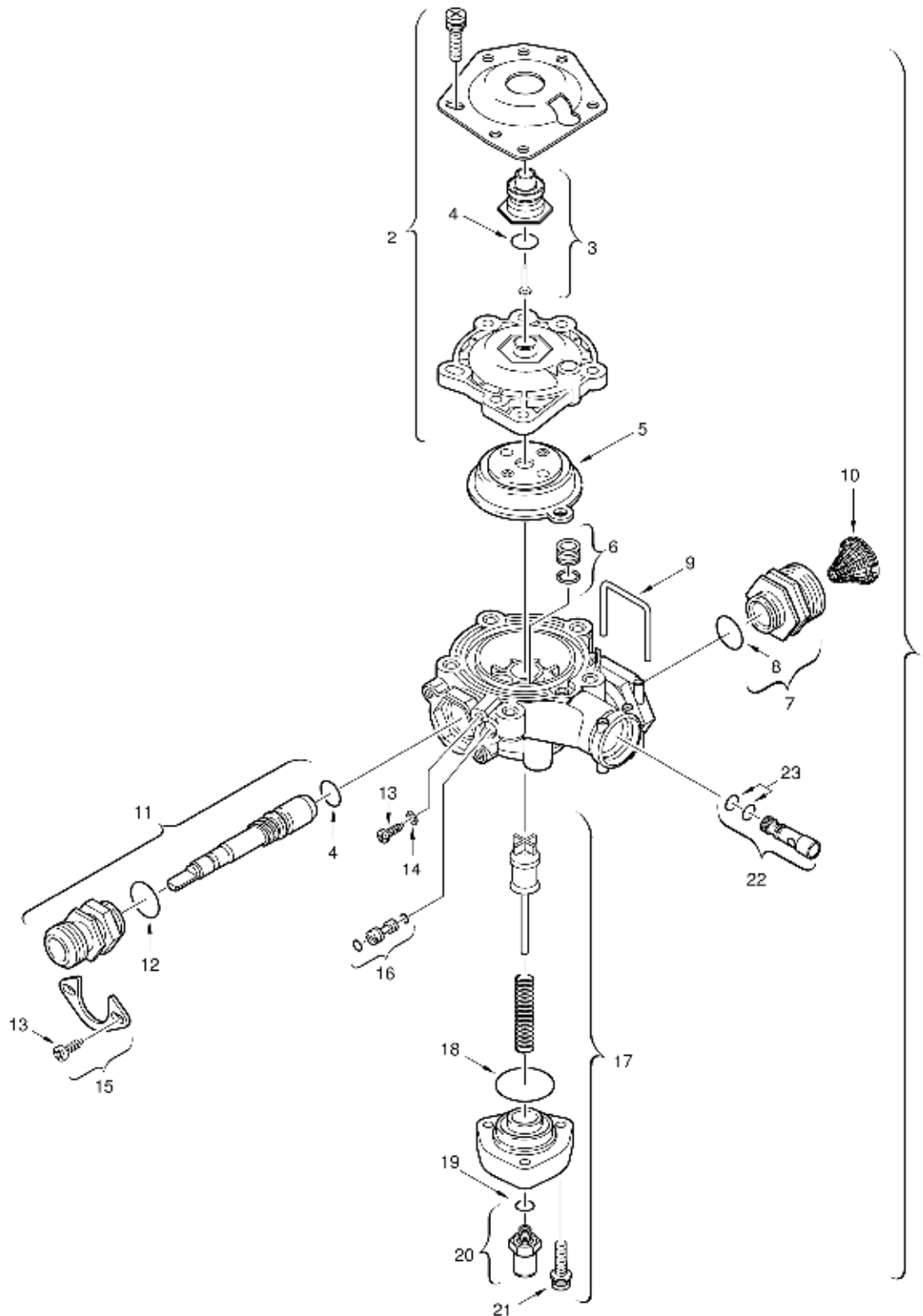

E72090E219.A.V.F

5

Aut. de água C/abast. Distância (Poli.)
Water valve multi point (plastic)
Wasserarmatur Fernzapfer (Kunststoff)
Robinet d'eau à distance (plastique)
Gruppo acqua prelievo a dist.in plastica
Cuerpo de agua servicio rem. (poliamida)

A

WR 200 / 250/ 325 - 5 AM. E..

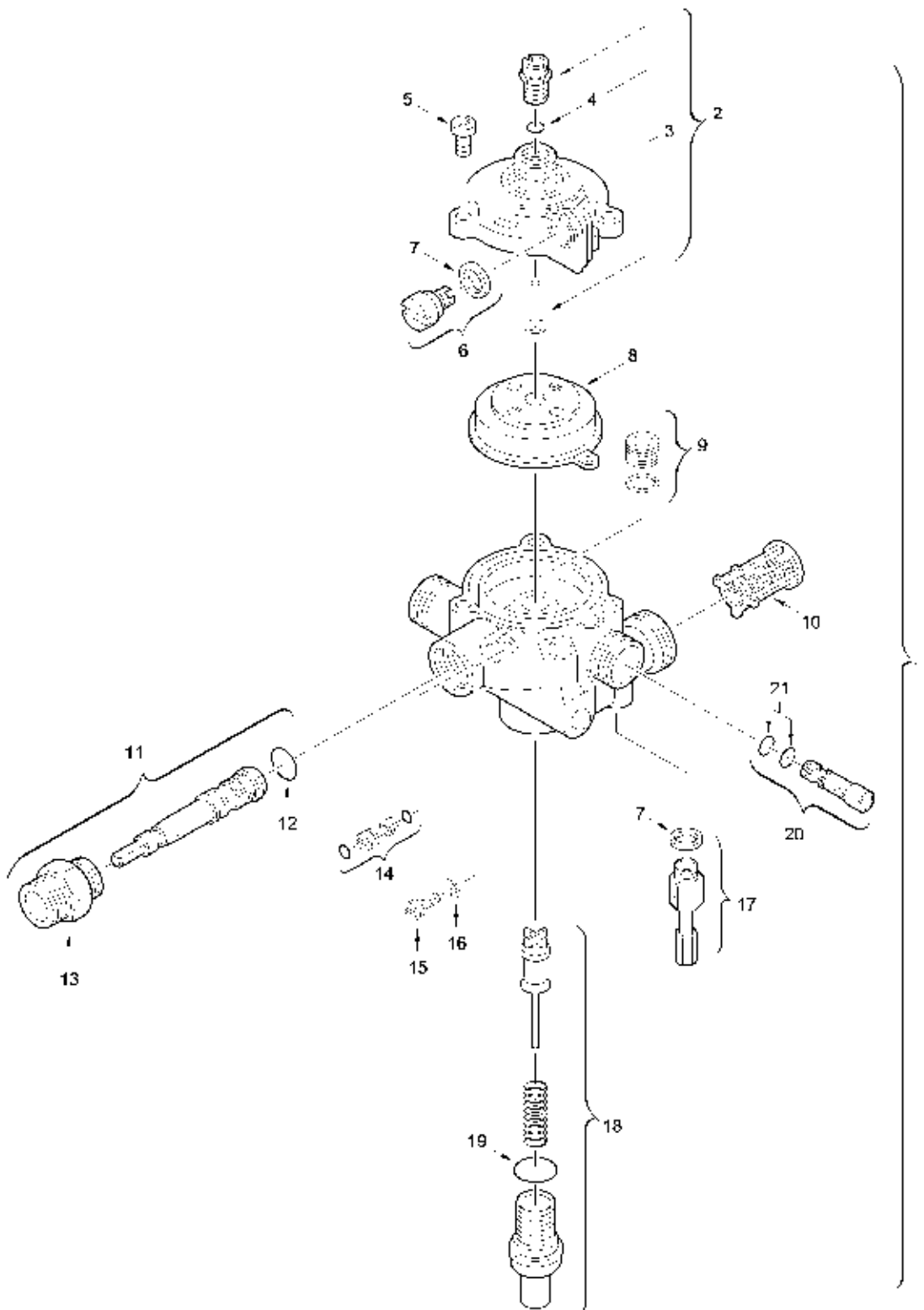

672083Z20_AA_11

5
B

Aut. de água C/abast. Distância (Latão)
Water valve multi point (brass)
Wasserarmatur Fernzapfer (Messing)
Robinet d'eau à distance (laiton)
Gruppo acqua prelievo a dist. in ottone
Cuerpo de agua servicio remoto (latón)

WR 200 / 250/ 325 - 5 AM. E..

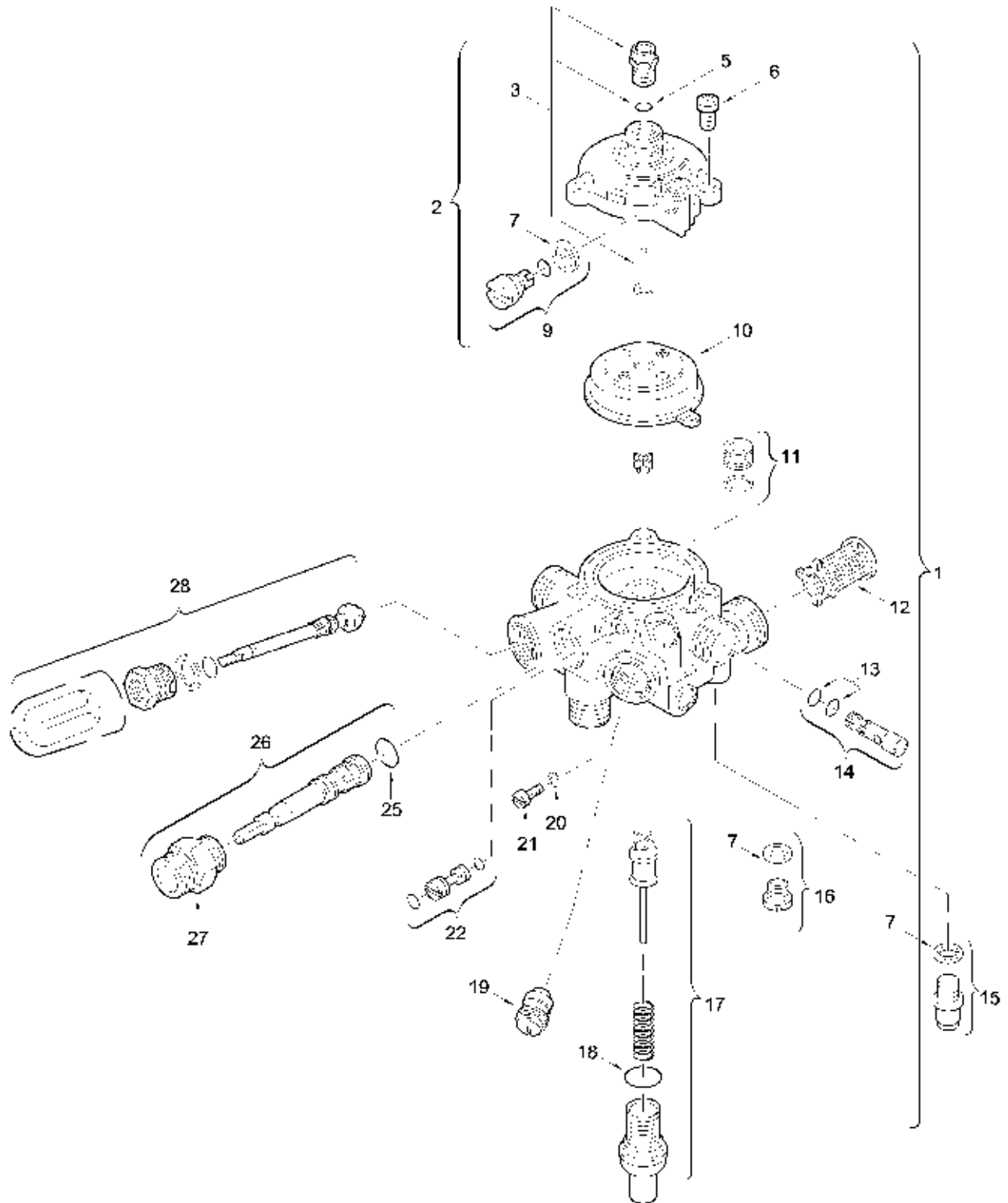

W/20962221 AA JI

5

Aut. de água C/abast. Directo (Latão)
Water valve single point (brass)
Wasserarmatur Direktzapfer (Messing)
Robinet d'eau direct (laiton)
Gruppo acqua prelievo diretto in ottone
Cuerpo de agua servicio directo (latón)

WR 200 / 250/ 325 - 5 AM. E..

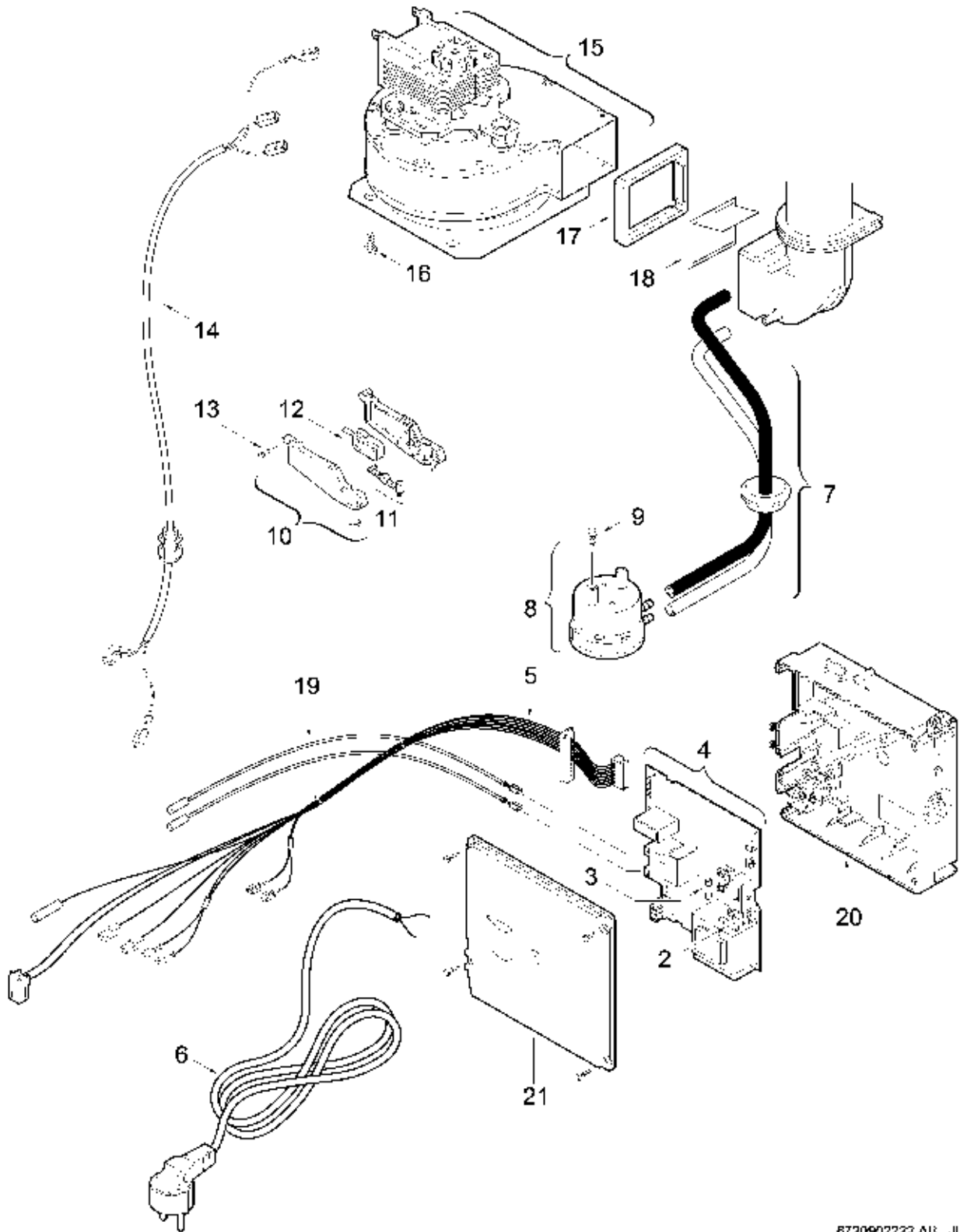

8720907777 A13 JI

6

Ventilador/Unidade de comando
Fan/Control box
Gebläse/Schaltkasten
Ventilateur/Tableau de commande
Ventilatore/Quadro comandi
Ventilador/Caja de conexiones

WR 200 / 250/ 325 - 5 AM. E..

Lista das traduções List of translations		Übersetzungsliste Liste des traductions		Traduzione delle descrizioni Lista de traducciones	
Pos	Description	Beschreibung	Denomination	Descrizione	Descripción
1	Element of construction	Baugruppe	Groupe de construction	Gruppo di costruzione	Grupo de construccion
1	Front cover	Mantel	Habillage	Mantello	Carcasa
1	Front shell	Mantel	Habillage	Mantello	Carcasa
1	Front cover	Mantel	Habillage	Mantello	Carcasa
2	Observation window	Schauglas	Hublot	Vetrino	Mirilla de observación
3	Shield	Blende	Cache	Mascherina	Chapa cuadro
4	Water flow selector handle	Griff Wassermengenwähler	Manette sèlecteur de débit eau	Manopola con boccola	Mando selector de caudal
5	Water flow selector handle	Griff	Manette	Manopola	Mando del grifo
6	Covering sheet	Deckel	Couvercle	Corperchio	Tapa
6	Trade mark badge	Warenzeichen	Marquage	Targhetta	Marca
7	Screw (10x)	Schraube (10x)	Vis (10x)	Vite (10x)	Tornillo (10x)
9	Washer set	Dichtungssatz	Sachet de joints	Set di guarnizioni	Conjunto de juntas
10	Angle bracket	Winkel	Equerre	Staffa	Angulo
10	Holding bracket	Winkel	Equerre	Staffa	Angulo
11	Screw M4,8x9,5 (10x)	Schraube M4,8x9,5 (10x)	Vis M4,8x9,5 (10x)	Vite M4,8x9,5 (10x)	Tornillo M4,8x9,5 (10x)
12	Sealings x 5	Dichtungssatz	Sachet de joints	Set di guarnizioni	Conjunto de juntas
13	Inlet air cover	Abdeckblech	Couvercle d'étanchéité	Lamierina di protezione	Chapa de protección
14	Gasket (10x)	Dichtring (10x)	Joint (10x)	Guarnizione (10x)	Anillo junta (10x)
15	Pipe - exhaust union	Abgasstutzen	Collerette de buse	Terminale condotto	Acoplamiento salida gas
16	Screw M4 x 12 phillips (10x)	Schraube (10x)	Vis (10x)	Vite (10x)	Tornillo (10x)
17	Clip	Schelle	Support	Staffa	Abrazadera
18	Screw	Schraube (10x)	Vis (10x)	Vite (10x)	Tornillo (10x)
19	Washer (10x)	Dichtung (10x)	Joint (10x)	Guarnizione (10x)	Junta (10x)
20	Pipe - fitting	Anschlusskrümmer	Tubulure	Bocchetta di collegamento	Tubuladura
21	Fixing bracket	Wandhalterung	Equerre	Staffa	Angulo de soporte
22	Flue union	Adapter	Buse de fumée	Flue union	Acoplamiento salida gas
23	Rotary handles	Drehgriffe	Croisillons	Manopola	Grifo de girar
2	Element of construction	Baugruppe	Groupe de construction	Gruppo di costruzione	Grupo de construccion
1	Heating body	Innenkörper	Corps de chauffe	Corpo interno	Cuerpo de caldeo
2	Washer 25OD X 21ID X 2MM (10x)	Dichtscheibe (10x)	Joint (10x)	Guarnizione (10x)	Junta (10x)
3	Locknut G 1/2" (10x)	Mutter (10x)	Ecrou (10x)	Dado (10x)	Tuerca (10x)
4	Temperature limiter	Temperaturbegrenzer	Limiteur de température	Limitatore temperatura di sicurezza	Limitador de temperatura
5	Pipe - cold water	Verbindungsrohr kalt	Tube arrivée eau	Tubo di raccordo acqua fredda	Tubo de agua fria
6	Washer 18.6x13.5x1.5 (10x)	Dichtung 18.6x13.5x1.5 (10x)	Joint 18.6x13.5x1.5 (10x)	Guarnizione 18.6x13.5x1.5 (10x)	Anillo junta 18.6x13.5x1.5 (10x)
7	Retaining clip (10x)	Bügel (10x)	Epingle (10x)	Fermo a molla (10x)	Clip de fijación (10x)
8	O-ring (10x)	O-Ring (10x)	O-ring (10x)	Anello tenuta (10x)	Anillo tórico (10x)
9	Drain off valve	Auslaufventil	Soupape de supression	Valvola mandata	Válvula de sobrepresión
10	Washer (10x)	Dichtscheibe (10x)	Joint (10x)	Guarnizione (10x)	Junta (10x)
11	Pipe - hot water	Verbindungsrohr warm	Tube sortie sanitaire	Raccordo caldo	Tubo agua caliente
12	Pipe	Rohr	Tube	Tubo	Tubo
13	Pipe	Rohr	Tube	Tubo	Tubo
14	Screw (10x)	Schraube (10x)	Vis (10x)	Vite (10x)	Tornillo (10x)
14	Screw M4x6mm steel phillips pan hd (10x)	Schraube (10x)	Vis (10x)	Vite (10x)	Tornillo (10x)
15	Hose	Flexschlauch	Tube flexible eau chaude	Tubo flessibile	Tubo Flexible
15	Hose	Schlauchverbindung	Tube flexible eau chaude	Tubo flessibile	Tubo Flexible
16	Washer (10x)	Dichtung (10x)	Joint (10x)	Guarnizione (10x)	Junta (10x)
17	Washer 23.9x17.2x1.5 (10x)	Dichtung 23.9x17.2x1.5 (10x)	Joint 23.9x17.2x1.5 (10x)	Guarnizione 23.9x17.2x1.5 (10x)	Anillo junta 23.9x17.2x1.5 (10x)
3	Element of construction	Baugruppe	Groupe de construction	Gruppo di costruzione	Grupo de construccion
1	Burner	Brenner	Brûleur	Brucciatore	Quemador
2	Connector	Anschlusstück	Raccord	Raccordo di collegamento	Colector
3	Washer (10x)	Dichtung (10x)	Joint (10x)	Guarnizione (10x)	Junta (10x)
4	Nozzle (115) (10x)	Düse (115) (10x)	Injecteur (115) (10x)	Ugello (115) (10x)	Tobera (115) (10x)
4	Nozzle (125) (10x)	Düse (125) (10x)	Injecteur (125) (10x)	Ugello (125) (10x)	Tobera (125) (10x)
4	Nozzle (120) (10x)	Düse (120) (10x)	Injecteur (120) (10x)	Ugello (120) (10x)	Tobera (120) (10x)
4	Nozzle (74) (10x)	Düse (74) (10x)	Injecteur (74) (10x)	Ugello (74) (10x)	Tobera (74) (10x)
4	Nozzle (72) (10x)	Düse (72) (10x)	Injecteur (72) (10x)	Ugello (72) (10x)	Tobera (72) (10x)
4	Nozzle (136) (10x)	Düse (136) (10x)	Injecteur (136) (10x)	Ugello (136) (10x)	Tobera (136) (10x)

Lista das traduções List of translations		Übersetzungsliste Liste des traductions		Traduzione delle descrizioni Lista de traducciones	
Pos	Description	Beschreibung	Denomination	Descrizione	Descripción
5	Screw (10x)	Schraube (10x)	Vis (10x)	Vite (10x)	Tornillo (10x)
6	Screw M4 x 12 phillips (10x)	Schraube (10x)	Vis (10x)	Vite (10x)	Tornillo (10x)
7	Screw M3,5x10 (10x)	Schraube M3,5x10 (10x)	Vis M3,5x10 (10x)	Vite M3,5x10 (10x)	Tornillo M3,5x10 (10x)
8	Pressure tapping	Druckmeßnippel	Prise de pression	Presa pressione	Toma de presión
9	Cross ignition bridge	Überzündbrücke	Tôle d'interallumage	Ponte accensione	Rampa de encendido
10	Washer 1" (10x)	Dichtscheibe 1" (10x)	Joint 1" (10x)	Guarnizione 1" (10x)	Junta 1" (10x)
11	Angle bracket	Verbindungswinkel	Tôle deflecteur	Angolare	Angulo
12	Screw (10x)	Schraube (10x)	Vis (10x)	Vite (10x)	Tornillo (10x)
13	Ignition electrode	Zündelektrode	Electrode d'allumage	Elettrodo accensione	Electrodo de encendido
14	Sensing electrode	Elektrode	Electrode	Elettrodo	Electrodo
15	Throttle disc (4,0) (10x)	Drosselscheibe (4,0) (10x)	Diaphragme (4,0) (10x)	Disco strozzatore (4,0) (10x)	Disco de estrangulación (4,0) (10x)
15	Throttle disc (5,1)	Drosselscheibe (5,1)	Diaphragme (5,1)	Disco strozzatore (5,1)	Disco de estrangulación (5,1)
15	Throttle disc (4,8)	Drosselscheibe (4,8)	Diaphragme (4,8)	Disco strozzatore (4,8)	Disco de estrangulación (4,8)
15	Throttle disc (5,6) (10x)	Drosselscheibe (5,6) (10x)	Diaphragme (5,6) (10x)	Disco strozzatore (5,6) (10x)	Disco de estrangulación (5,6) (10x)
15	Throttle disc (6,2)	Drosselscheibe (6,2)	Diaphragme (6,2)	Disco strozzatore (6,2)	Disco de estrangulación (6,2)
15	Throttle disc (5,4)	Drosselscheibe (5,4)	Diaphragme (5,4)	Disco strozzatore (5,4)	Disco de estrangulación (5,4)
15	Throttle disc (6,5)	Drosselscheibe (6,5)	Diaphragme (6,5)	Disco strozzatore (6,5)	Disco de estrangulación (6,5)
	Gas conversion kit GN>GPL	Gasart-Umbausatz GN>GPL	Kit de transformation de gaz GN>GPL	Kit conversione gas GN>GPL	Kit de conversión de gas GN>GPL
	Gas transformation kit 23»31	Umbausatz 23»31	Pochette Transformation Gas 23»31	Set di trasformazione Gas 23»31	Kit de transformacion Gas 23»31
	Gas transformation UR200-1AME2-3NL	Umbausatz UR200-1AME2-3NL	Pochette Transformation UR200-1AME2-3NL	Set di trasformazione UR200-1AME2-3NL	Kit de transformacion UR200-1AME2-3NL
	Gas transformation kit UR325-3AME3-2CL	Umbausatz UR325-3AME3-2CL	Pochette Transformation Gas UR325-3AME3	Set di trasformazione Gas UR325-3AME3-2	Kit de transformacion UR325-3AME3-2CL
	Gas transformation kit 23?31	Umbausatz 23»31	Pochette Transformation Gas 23»31	Set di trasformazione Gas 23»31	Kit de transformacion Gas 23»31
	Gas transformation kit 23>31	Umbausatz 23>31	Pochette Transformation Gas 23>31	Set di trasformazione Gas 23>31	Kit de transformacion Gas 23>31
	Gas conversion kit 31>23	Gasart-Umbausatz 31>23	Kit de transformation de gaz 31>23	Kit conversione gas 31>23	Kit de conversión de gas 31>23
4A	Element of construction	Baugruppe	Groupe de construction	Gruppo di costruzione	Grupo de construccion
1	Gas valve	Gasarmatur	Bloc gaz	Gruppo gas	Cuerpo de gas
2	Solenoid-operated valve	Magnetventil kompl.	Electrovanne	Elettrovalvola completa	Electrovalvula completa
3	Solenoid-operated valve	Magnetventil	Electrovanne	Elettrovalvola completa	Electrovalvula
4	O-Ring (10x)	O-Ring (10x)	O-ring (10x)	Anello tenuta (10x)	Anillo tórico (10x)
5	Screw M5X12 steel phillips pan hd (10x)	Schraube (10x)	Vis (10x)	Vite (10x)	Tornillo (10x)
6	Washer cardboard	Scheibe	Rondelle	Rondella	Arandela
7	Nut	Mutter	Ecrou	Dado	Tuerca
8	Washer (10x)	Dichtung (10x)	Joint (10x)	Guarnizione (10x)	Junta (10x)
9	Compression spring	Druckfeder	Ressort	Molla antagonista	Muelle
10	Compression spring	Druckfeder	Ressort	Molla antagonista	Muelle
11	Poppet valve head (2E)	Gasventil (2E)	Soupape gaz (2E)	Valvola gas modul. (2E)	Conjunto de válvula (2E)
11	Poppet valve head (3E)	Gasventil (3E)	Soupape gaz (3E)	Valvola gas modul. (3E)	Conjunto de válvula (3E)
12	Poppet valve head (2)	Gasventil (2)	Soupape gaz (2)	Piattello della valvola (2)	Asiento de válvula (2)
12	Poppet valve head (3)	Gasventil (3)	Soupape gaz (3)	Piattello della valvola (3)	Asiento de válvula (3)
13	Valve stem	Ventilstift	Tige du clapet	Perno valvola	Vástago de válvula
14	O-ring (10x)	O-ring (10x)	O-ring (10x)	Anello tenuta (10x)	Anillo tórico (10x)
15	Gas filter (10x)	Gassieb (10x)	Filtre gaz (10x)	Filtro gas (10x)	Filtro de gas (10x)
16	Washer-fibre 24OD X 16ID X 2MM (10x)	Dichtscheibe (10x)	Joint (10x)	Guarnizione (10x)	Junta (10x)
17	Screw (10x)	Schraube (10x)	Vis (10x)	Vite (10x)	Tornillo (10x)
18	Valve operation housing	Schaltergehäuse	Support interrupteur	Gruppo accensione	Caja interruptor
19	Poppet valve head	Ventilteller	Siège de soupape	Piatello della valvola	Platillo de válvula
21	Retaining ring (10x)	Sicherungsscheibe (10x)	Circlips (10x)	Rondella (10x)	Arandela de seguridad (10x)
22	Compression spring	Druckfeder	Ressort	Molla antagonista	Muelle
23	Poppet valve head	Ventilteller	Siège de soupape	Piatello della valvola	Platillo de válvula
24	O-ring (10x)	O-Ring (10x)	O-ring (10x)	Anello tenuta (10x)	Anillo tórico (10x)
25	Washer (10x)	Dichtung (10x)	Joint (10x)	Guarnizione (10x)	Junta (10x)
26	Guide plate	Führungsplatte	Plaque de guidage	Pulsantiera	Placa de guía
27	Screw DIN7981 4,2x9,5 (10x)	Schraube DIN7981 4,2x9,5 (10x)	Vis 4,2x9,5 (10x)	Vite 4,2x9,5 (10x)	Tornillo (10x)
28	Pipe - gas supply	Gaszuführungsrohr	Tube arrivée gaz	Tubo gas	Tubo de entrada de gas
4B	Element of construction	Baugruppe	Groupe de construction	Gruppo di costruzione	Grupo de construccion
1	Gas valve	Gasarmatur	Bloc gaz	Gruppo gas	Cuerpo de gas
2	Solenoid-operated valve	Magnetventil kompl.	Electrovanne	Elettrovalvola completa	Electrovalvula completa

Lista das traduções List of translations		Übersetzungsliste Liste des traductions		Traduzione delle descrizioni Lista de traducciones	
Pos	Description	Beschreibung	Denomination	Descrizione	Descripción
3	Solenoid-operated valve	Magnetventil	Electrovanne	Elettrovalvola completa	Electrovalvula
4	O-Ring (10x)	O-Ring (10x)	O-ring (10x)	Anello tenuta (10x)	Anillo tórico (10x)
5	Screw M5X12 steel phillips pan hd (10x)	Schraube (10x)	Vis (10x)	Vite (10x)	Tornillo (10x)
6	Washer cardboard	Scheibe	Rondelle	Rondella	Arandela
7	Nut	Mutter	Ecrou	Dado	Tuerca
8	Washer (10x)	Dichtung (10x)	Joint (10x)	Guarnizione (10x)	Junta (10x)
9	Compression spring	Druckfeder	Ressort	Molla antagonista	Muelle
10	Compression spring	Druckfeder	Ressort	Molla antagonista	Muelle
11	Poppet valve head (2E)	Gasventil (2E)	Soupape gaz (2E)	Valvola gas modul. (2E)	Conjunto de válvula (2E)
11	Poppet valve head (3E)	Gasventil (3E)	Soupape gaz (3E)	Valvola gas modul. (3E)	Conjunto de válvula (3E)
12	Poppet valve head (2)	Gasventil (2)	Soupape gaz (2)	Piattello della valvola (2)	Asiento de válvula (2)
12	Poppet valve head (3)	Gasventil (3)	Soupape gaz (3)	Piattello della valvola (3)	Asiento de válvula (3)
13	Valve stem	Ventilstift	Tige du clapet	Perno valvola	Vástago de válvula
14	O-ring (10x)	O-ring (10x)	O-ring (10x)	Anello tenuta (10x)	Anillo tórico (10x)
15	Gas filter (10x)	Gassieb (10x)	Filtre gaz (10x)	Filtro gas (10x)	Filtro de gas (10x)
16	Washer-fibre 24OD X 16ID X 2MM (10x)	Dichtscheibe (10x)	Joint (10x)	Guarnizione (10x)	Junta (10x)
17	Screw (10x)	Schraube (10x)	Vis (10x)	Vite (10x)	Tornillo (10x)
18	Washer (10x)	Dichtung (10x)	Joint (10x)	Guarnizione (10x)	Junta (10x)
19	Pipe - gas supply	Gaszuführungsrohr	Tube arrivée gaz	Tubo gas	Tubo de entrada de gas
19	Gas supply pipe	Gaszuführungsrohr	Tube arrivée gaz	Tubo gas	Tubo de entrada de gas
20	Volumetric gas Governor	Gasmengenregler	Régulateur de débit gaz	Regolatore gas	Estabilizador de gas
5A	Element of construction	Baugruppe	Groupe de construction	Gruppo di costruzione	Grupo de construcción
1	Water valve - assembly	Wasserarmatur	Robinet d'eau	Gruppo acqua	Cuerpo de agua
1	Water valve	Wasserarmatur	Robinet d'eau	Gruppo acqua	Cuerpo de agua
2	Cover	Deckel	Couvercle	Coperchio	Tapa
3	Sleeve	Buchse	Douille	Buccola	Manguito
4	O-ring (10x)	O-Ring (10x)	O-ring (10x)	Anello tenuta (10x)	Anillo tórico (10x)
5	Diaphragm (A)	Membrane (A)	Membrane (A)	Membrana (A)	Membrana (A)
5	Diaphragm	Membrane (F)	Membrane (F)	Membrana (F)	Membrana (F)
6	Sleeve (10x)	Buchse (10x)	Douille (10x)	Buccola (10x)	Manguito (10x)
7	Inlet water connection	Buchse	Douille	Buccola	Manguito
8	O-ring (10x)	O-Ring (10x)	O-ring (10x)	Anello tenuta (10x)	Anillo tórico (10x)
9	Retaining clip (10x)	Bügel (10x)	Epingle (10x)	Fermo a molla (10x)	Clip de fijación (10x)
10	Water strainer (10x)	Wassersieb (10x)	Filtre eau (10x)	Filtro acqua (10x)	Filtro de agua (10x)
11	Selector screw	Wählerschraube	Vis de réglage	Selettore	Tornillo selector de caudal
11	Selector Screw	Wählerschraube	Vis de réglage	Selettore	Tornillo selector de caudal
12	O-ring (10x)	O-Ring (10x)	O-ring (10x)	Anello tenuta (10x)	Anillo tórico (10x)
13	Screw (10x)	Schraube (10x)	Vis (10x)	Vite (10x)	Tornillo (10x)
14	Retaining ring (10x)	Sicherungsscheibe (10x)	Circlips (10x)	Rondella (10x)	Arandela de seguridad (10x)
15	Plate	Druckplatte	Plaque d'appui	Staffa	Plato
16	Plunger	Spindel	Goupille	Perno	Vástago
17	Volumetric water governor	Wassermengenregler	Regleur de débit eau	Regolatore portata	Estabilizador de caudal
18	O-ring (10x)	O-Ring (10x)	O-ring (10x)	Anello tenuta (10x)	Anillo tórico (10x)
19	O-ring (10x)	O-Ring (10x)	O-ring (10x)	Anello tenuta (10x)	Anillo tórico (10x)
20	Connector	Reglgerhäuse	Connecteur microsicht	Raccordo	Casquillo
21	Screw (10x)	Schraube (10x)	Vis (10x)	Vite (10x)	Tornillo (10x)
22	Venturi (23s)	Venturi (23 S)	Venturi (23S)	Venturi (23S)	Venturi (23S)
23	O-ring (10x)	O-Ring (10x)	O-ring (10x)	Anello tenuta (10x)	Anillo tórico (10x)
5B	Element of construction	Baugruppe	Groupe de construction	Gruppo di costruzione	Grupo de construcción
1	Water valve	Wasserarmatur	Robinet d'eau	Gruppo acqua	Cuerpo de agua
2	Cover	Deckel	Couvercle	Coperchio	Tapa del cuerpo de agua
5	Screw (10x)	Schraube (10x)	Vis (10x)	Vite (10x)	Tornillo (10x)
6	Slow-ignition valve (c)	Langsamzündventil (C)	Vanne d'allumage progressif (C)	Valvolina lente accensione (C)	Válvula de encendido lento (C)
7	Washer (10x)	Dichtscheibe (10x)	Joint (10x)	Guarnizione (10x)	Junta (10x)
8	Diaphragm (A)	Membrane (A)	Membrane (A)	Membrana (A)	Membrana (A)
8	Diaphragm	Membrane (F)	Membrane (F)	Membrana (F)	Membrana (F)
9	Sleeve (10x)	Buchse (10x)	Douille (10x)	Buccola (10x)	Manguito (10x)

Lista das traduções List of translations		Übersetzungsliste Liste des traductions		Traduzione delle descrizioni Lista de traducciones	
Pos	Description	Beschreibung	Denomination	Descrizione	Descripción
10	Inlet filter	Wassersieb	Filtre eau	Filtro acqua	Filtro de agua
11	Selector Screw	Wählerschraube	Vis de réglage	Selettore	Tornillo selector de caudal
11	Selector screw	Wählerschraube	Vis de réglage	Selettore	Tornillo selector de caudal
12	O-ring (10x)	O-Ring (10x)	Joint torique (10x)	Anello tenuta (10x)	Anillo tórico (10x)
13	Sleeve	Buchse	Douille	Buccola	Manguito
14	Plunger	Spindel	Goupille	Perno	Vástago
15	Screw (10x)	Schraube (10x)	Vis (10x)	Vite (10x)	Tornillo (10x)
16	Retaining ring (10x)	Sicherungsscheibe (10x)	Circlips (10x)	Rondella (10x)	Arandela de seguridad (10x)
17	Drain off valve	Auslaufventil	Soupape de supression	Valvola mandata	Válvula de sobrepresión
18	Volumetric water governor	Wassermengenregler	Regleur de débit eau	Regolatore portata	Estabilizador de caudal
19	O-ring (10x)	O-Ring (10x)	Joint torique (10x)	Anello tenuta (10x)	Anillo tórico (10x)
20	Venturi (13)	Venturi (13)	Venturi (13)	Venturi (13)	Venturi (13)
21	O-ring (10x)	O-Ring (10x)	O-ring (10x)	Anello tenuta (10x)	Anillo tórico (10x)
5C	Element of construction	Baugruppe	Groupe de construction	Gruppo di costruzione	Grupo de construccion
1	Water valve	Wasserarmatur	Robinet d'eau	Gruppo acqua	Cuerpo de agua
2	Cover	Deckel	Couvercle	Coperchio	Tapa del cuerpo de agua
6	Screw (10x)	Schraube (10x)	Vis (10x)	Vite (10x)	Tornillo (10x)
7	Washer (10x)	Dichtscheibe (10x)	Joint (10x)	Guarnizione (10x)	Junta (10x)
9	Slow-ignition valve (c)	Langsamzündventil (C)	Vanne d'allumage progressif (C)	Valvolina lente accensione (C)	Válvula de encendido lento (C)
10	Diaphragm (G)	Membrane (G)	Membrane (G)	Membrana (G)	Membrana (G)
10	Diaphragm (J)	Membrane (J)	Membrane (J)	Membrana (J)	Membrana (J)
10	Diaphragm (E)	Membrane (E)	Membrane (E)	Membrana (E)	Membrana (E)
11	Sleeve (10x)	Buchse (10x)	Douille (10x)	Buccola (10x)	Manguito (10x)
12	Inlet filter	Wassersieb	Filtre eau	Filtro acqua	Filtro de agua
13	O-ring (10x)	O-Ring (10x)	O-ring (10x)	Anello tenuta (10x)	Anillo tórico (10x)
14	Venturi (13)	Venturi (13)	Venturi (13)	Venturi (13)	Venturi (13)
15	Drain off valve	Auslaufventil	Soupape de supression	Valvola mandata	Válvula de sobrepresión
17	Volumetric water governor	Wassermengenregler	Regleur de débit eau	Regolatore portata	Estabilizador de caudal
18	O-ring (10x)	O-Ring (10x)	Joint torique (10x)	Anello tenuta (10x)	Anillo tórico (10x)
19	Sealing screw	Verschlußschraube	Vis de fermeture	Vite di chiusura	Tornilla de cierre
20	Retaining ring (10x)	Sicherungsscheibe (10x)	Circlips (10x)	Rondella (10x)	Arandela de seguridad (10x)
21	Screw (10x)	Schraube (10x)	Vis (10x)	Vite (10x)	Tornillo (10x)
22	Plunger	Spindel	Goupille	Perno	Vástago
25	O-ring (10x)	O-Ring (10x)	Joint torique (10x)	Anello tenuta (10x)	Anillo tórico (10x)
26	Selector Screw	Wählerschraube	Vis de réglage	Selettore	Tornillo selector de caudal
26	Selector screw	Wählerschraube	Vis de réglage	Selettore	Tornillo selector de caudal
27	Sleeve	Buchse	Douille	Buccola	Manguito
28	Globe valve	Zubehör Nr.434	Robinet à soupape	Accessorio N° 434	Accesorio N° 434
6	Element of construction	Baugruppe	Groupe de construction	Gruppo di costruzione	Grupo de construccion
2	Fusing element T0,8A	Sicherung T0,8A (10x)	Fusible T0,8A (10x)	Fusibile T0,8A (10x)	Fusible T0,8A (10x)
3	Fuse T1,25A	Sicherung T1,25A (10x)	Fusible T1,25A (10x)	Fusibile T1,25A (10x)	Fusible T1,25A (10x)
4	Printed circuit board	Leiterplatte	Circuit imprimé	Scheda elettronica	Circuito impreso
5	Set of cables 24v	Kabelbaum 24V	Faisceau 24V	Cablaggio 24V	Conjunto cables 24V
6	Power supply cord	Kabel	Câble	Cavo d'alimentazione	Cable de alimentación
7	Pressure switch hose set	Schlauchsatz	Sachet de tuyau	Tubetto	Conjunto de tubo flexible
8	Differential pressure switch	Differenzdruckschalter	Pressostat	Interruttore pressione differenziale	Interruptor diferencia de presión
9	Screw (10x)	Schraube (10x)	Vis (10x)	Vite (10x)	Tornillo (10x)
10	Microswitch	Mikroschalter	Microrupteur complet	Microinterruttore	Microinterruptor
11	Lever	Hebel	Levier	Leva	Palanca
12	Microswitch	Mikroschalter	Microrupteur	Microinterruttore	Microinterruptor
13	Screw (10x)	Schraube (10x)	Vis (10x)	Vite (10x)	Tornillo (10x)
14	Centrifugal blower cables	Gebälseleitung	Faisceau ventilateur	Cablaggio ventilatore	Ventilador cable
15	Centrifugal blower	Gebälse	Ventilateur	Ventilatore	Ventilador
16	Screw M4,8x9,5 (10x)	Schraube M4,8x9,5 (10x)	Vis M4,8x9,5 (10x)	Vite M4,8x9,5 (10x)	Tornillo M4,8x9,5 (10x)
17	Washer	Dichtung	Joint	Guarnizione	Junta
18	Support	Halter	Palette	Limitatore di scarico	Pletina
19	Ignition cable	Zündkabel	Conduite d'allumage	Cavetto accensione	Conductor de alta tensión

Tipos de dispositivos Types of appliances	Gerätetypen Types de chaudières		Tipo apparecchi Tipos de aplicaciones	
Aparelho Appliance Gerät Chaudière Apparecchio Aparato	N° de pedido Ordering no. Bestell-Nr. Numéro de commande N° d'ordine Número el ordenar	Pais Country Land Pays Paese Paese	S-Nr. S-Nr. S-Nr. S-Nr. S-Nr. S-Nr.	Observações Remarks Bemerkungen Remarques Osservazioni Observaciones
WR325-5AM1E23S2205	7 702 311 034	Argentina	2205	
WR325-5AM1E32S2205	7 702 411 035	Argentina	2205	
WR325-5AM1E23S4305	7 702 311 031	Bolívia,Chile	4305	
WR325-5AM1E31S4305	7 702 411 032	Bolívia,Chile	4305	
WR325-5AM1E23S3605	7 702 311 026	Bélgica	3605	
WR325-5AM1E31S3605	7 702 411 026	Bélgica	3605	
WR325-5AM1E23S2805	7 702 311 027	Espanha	2805	
WR325-5AM1E31S2805	7 702 411 027	Espanha	2805	
WR200-5AM0E5S0700	7 701 210 017	Holanda	0700	
WR325-5AM0E5S0700	7 702 210 014	Holanda	0700	
WR250-5AM0E5S0700	7 701 210 018	Holanda,Ucrânia	0700	
WR325-5AM1E23S0506	7 702 311 028	Inglaterra	0506	
WR325-5AM1E31S0506	7 702 411 028	Inglaterra	0506	
WR250-5AM1E31S4900	7 701 411 028	Israel	4900	
WR325-5AM1E31S4900	7 702 411 031	Israel	4900	
WR250-5AM1E23S0404	7 701 311 026	Itália	0404	
WR250-5AM1E31S0404	7 701 411 025	Itália	0404	
WR325-5AM1E23S0404	7 702 311 025	Itália	0404	
WR325-5AM1E31S0404	7 702 411 025	Itália	0404	
WR250-5AM1E23S3505	7 701 311 027	Portugal	3505	
WR250-5AM1E23S3506	7 701 311 028	Portugal	3506	
WR250-5AM1E31S3505	7 701 411 026	Portugal	3505	
WR250-5AM1E31S3506	7 701 411 027	Portugal	3506	
WR325-5AM1E23S3505	7 702 311 029	Portugal	3505	
WR325-5AM1E23S3506	7 702 311 030	Portugal	3506	



BOSCH

x

Bosch Thermotechnik GmbH
Junkersstr. 20-24
D-73249 Wernau / Germany