



**WDH-3 2.160-2.180-2.220-2.250-2.280-2.300-
2.320-2.340-2.360-2.420-2.450-2.480-2.540-2.600**

WATER COOLED CHILLERS

Installation and Use Manual

UNIT IDENTIFICATION	4
GENERAL WARNINGS	5
RESIDUAL RISKS	6
REFRIGERANT SAFETY CHARTS.....	7
RECEPTION	9
INSPECTION UPON RECEPTION.....	9
STORAGE.....	9
HANDLING.....	9
POSITIONING	11
GENERAL.....	11
FUNCTIONAL CLEARANCES.....	11
POSITIONING.....	11
WATER CONNECTIONS	14
GENERAL.....	14
EXCHANGER USE SIDE.....	14
DIAGRAM OF RECOMMENDED USE SIDE CONNECTION.....	15
RECOVERY EXCHANGER.....	15
VICTAULIC CONNECTIONS.....	15
RECOMMENDED SOURCE SIDE CONNECTION SCHEMA.....	16
SYSTEM MEASURES ON SOURCE SIDE.....	17
ELECTRICAL CONNECTION	18
GENERAL.....	18
STANDARD UNIT ELECTRICAL DATA.....	18
CONNECTION TO THE MAINS.....	19
CLIVET TALK MODULAR SYSTEM COMPOSITION.....	21
MODBUS - CONVERTER CAN to MODBUS via RS 485.....	23
START-UP	25
PRELIMINARY CHECKS.....	25
REFRIGERANT SYSTEM.....	25
WATER SYSTEM.....	25
ELECTRICAL SYSTEM.....	25
VERIFy tensions – absorptions.....	25
REMOTE INPUT CONFIGURATIONS.....	25
SETTING THE SET-POINT.....	25
EVAPORATOR WATER FLOW RATE.....	26
CONDENSER WATER FLOW RATE.....	26
REFRIGERANT CIRCUIT PARAMETER CHECK.....	26
CONTROL	27
ROUTINE MAINTENANCE	37
MAINTENANCE INSPECTIONS.....	38
97/23 CE PED directive.....	38
PUT AT REST.....	38
REFRIGERANT TABLES.....	39
TROUBLESHOOTING	41
DECOMMISSIONING OF THE UNIT	42
DISCONNECTING THE UNIT.....	42
DISMANTLING AND DISPOSAL.....	42
TECHNICAL DATA	43
SOUND LEVELS.....	48
DIMENSIONS	49

UNIT IDENTIFICATION

SERIAL NUMBER LABEL

The units are identified by the serial number label shown here.

The label lists the type of unit (series and size), serial number, year of manufacture, number of electrical diagram, main technical data, logo and address of the manufacturer.

The label is placed on the unit, generally near the electrical panel and also on the external panelling.

IT MUST NEVER BE REMOVED.

SERIAL NUMBER

This provides unique identification of the machine. It makes it possible to trace the specific features of the unit and to identify the components installed in it.

Without this number, it is not possible to identify with certainty the spare parts that are specific to that unit.

When requesting assistance, always provide the type of machine and the serial number.

Write them in the space below so that they are readily available when needed.

Type of unit : _____

Serial number : _____

Wiring diagram : _____

Year of manufacture : _____

<div style="display: flex; justify-content: space-around; align-items: center;"> <div style="border: 1px dashed black; padding: 5px; font-weight: bold; font-size: 1.2em;">LOGO</div> <div style="font-size: 2em; font-weight: bold;">CE</div> </div>	
TIPO TYPE/TYP TYPE/TIPO	
NUMERO MATRICOLA SERIAL NUMBER / SERIENNUMMER NUMERO DE SERIE / NUMERO DE SERIE	
ANNO DI FABBRICAZIONE YEAR OF MANUFACTURE / BAUJAHR ANNEE DE FABRICATION / AÑO DE FABRICACIÓN	
REFRIGERANTE REFRIGERANT / KÄLTEMITTEL REFRIGERANT / REFRIGERANTE	GRUPPO (PED) GROUP / GRUPE GROUPE / GRUPO
CARICA REFRIGERANTE REFRIG. CHARGE / KÄLTEMITTELFÜLLUNG CHARGE REFRIG./CARGA REFRIG.	Kg
TENSIONE VOLTAGE / SPANNUNG TENSION / TENSION	V/Ph/Hz
F.L.A.	A
F.L.I.	kW
SCHEMA ELETTRICO WIRING DIAGRAM / SCHALTPLAN SCHEMA ELECTRIQUE/ESQUEMA ELÉCTRICO	N°
PRESSIONE MASSIMA ESERCIZIO MAX OPERATING PRESS. / MAX BETRIEBSDRUCK PRESS. DE SERVICE MAXI/PRESION DE EJERCICIO MÁX	bar
CATEGORIA PED PED CATEGORY / PED KATEGORIE CATEGORIE PED / CATEGORIA PED	PS H/L bar
TEMP. LATO BP TEMPERATURE ON LP SIDE / TEMP. ND-SEITE TEMP. COTE BP / TEMP. PARTE BP	°C
INDIRIZZO / ADDRESS / ADRESSE / ADRESSE / DIRECCION	

GENERAL WARNINGS

MANUAL PURPOSE

This manual has been designed to enable the unit to be installed, started up and maintained correctly.

MANUAL INSTRUCTIONS

It is essential to observe these instructions. The manufacturer declines all liability for any damage that may be caused whether directly or indirectly to persons or things if these instructions are not heeded.

MANUAL STORAGE

This manual and the unit's wiring diagram should be carefully stored so that they are readily available to the operator when required.

EXPERT PERSONAL

The unit must be installed, tested and maintained by expert personal who meet the relevant legal requirements (Italian law No. 46 of 5/3/1990).

LOCAL SAFETY REGULATION INSTALLATION

The installation must be performed observing the local safety regulations.

POWER SUPPLY

Make sure the power supply conforms to the data on the unit's rating plate, located inside the door of the main electrical panel.

PACKAGING

The packaging material (plastic bags, polystyrene foam, nails, etc.) is potentially dangerous and should therefore be kept away from children and recycled in compliance with the local regulations in force.

MAINTENANCE

Before performing any service operations, cut off the power. Perform the operations in conformity with the local regulations in force.

PERIODICAL INSPECTIONS

Perform periodical inspections to locate possible loosened or broken parts. If the repairs are not performed, there will be a higher risk for things and peoples to become damaged and injured.

FAULT – POOR OPERATION

Switch off the unit in the event of faults or poor operation.

REPAIR

Only have repairs carried out by a service centre authorised by the manufacturer, and insist on the use of original spare parts only.

Failure to comply with the above may compromise the safety of the unit.

MODIFICATIONS

The manufacturer will not accept any responsibility, and the warranty will lapse, in the event of electric and/or mechanical modifications. Any modification which is not formally authorized, and which does not respect the instructions given in this manual, will cause the warranty to lapse.

INTENDED USE

The unit must only be used for the specific purpose it was designed :

The unit is designed to cool/heat water or a water and glycol mix for air-conditioning, within the limits defined in the technical bulletin and this manual.

Any use other than that specified does not imply any commitment or constraint by the manufacturer in any way whatsoever.

ADDITIONAL SAFETY PRECAUTIONS

This unit has been especially designed and manufactured so to prevent any risk to persons and health hazard.

For this reason, design solutions fit to eliminate (where possible) any cause of risk and sensibly reduce the probability of danger have been adopted.

Please refer to the "Residual Risks" section of this manual and strictly observe the behaviour prescriptions listed there in order to prevent any possible risk that hasn't been possible to avoid in the design stage.

DATA UPDATING

The manufacturer may be able to modify the data without prior notice as a consequence of constant improvements.

REGULATIONS AND CERTIFICATIONS

UNI EN ISO 9001 CERTIFICATION

Clivet S.p.A., in order to guarantee customer satisfaction, has chosen the ISO 9001 Quality System as the reference for all its business activities. This is demonstrated by the company's commitment to ongoing improvements in the quality and reliability of its products; its sales, design, purchasing, production and after-sales service activities are the means used to reach such purpose.

CE MARK



Clivet products bear the CE mark, in compliance with the requirements of the following EC directives, including the latest amendments, and with the corresponding national approximated legislation:

- - 98/37/CE
- - 89/336/CEE as modified by the directives 92/31/CEE and 93/68/CEE
- - 73/23/CEE as modified by the directive 93/68/CEE
- - 97/23/CE

EUROVENT CERTIFICATION



Clivet is participating in the EUROVENT Certification Programme "Liquid Chilling Packages". Products are listed in the EUROVENT Directory of Certified Products and in the site www.eurovent-certification.com. Eurovent Chillers Certification Programme covers air cooled packaged chillers up to 600 kW and water cooled packaged chillers up to 1500 kW.

RESIDUAL RISKS

GENERAL

This section lists some of the more common situations which, being beyond the control of the manufacturer, could be a source of risk to persons or property.

DANGER AREA

The figure below highlights the area in which only authorised personnel may operate.

- **External danger zone**, identified by a precise area around the unit and its vertical projection on the ground in the case of hanging unit.
- **Internal danger zone**, identified by the area that can be entered only after having intentionally removed the protecting panels or parts of these.

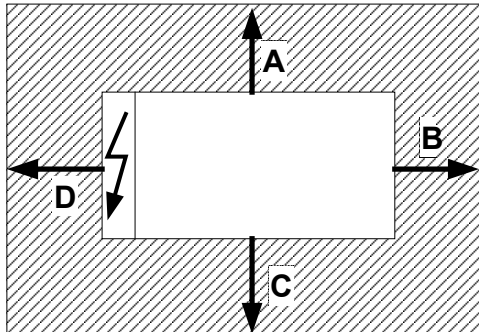

A = 2000mm B = 2000mm
C = 2000mm D = 2000mm

HANDLING

If handling operations are undertaken without adopting all the necessary safety procedures and exercising due care, the unit can fall or topple, causing damage — possibly extremely serious — to persons and/or property, and to the unit itself.

Ensure the unit is handled and manoeuvred as directed on the packing and in the present manual, and in accordance with local regulations.

In the event of refrigerant gas escaping, refer to the “Safety datasheet” for the particular refrigerant.

INSTALLATION

Incorrect installation of the unit can result in water leaks, accumulation of condensate, escape of refrigerant, electric shocks, fire, as well as irregular operation or damage to the unit itself.

Make certain that the installation is carried out only by a qualified technician, also that the directions contained in this manual are followed and local statutory regulations observed.

In the event of the unit being installed in a site where there is even the slightest risk of inflammable gas escapes and consequently the possibility of such gases accumulating in area around the unit, the risk of explosion and fire cannot be discounted.

Take every care and precaution when selecting the installation site.

Installation on a structure not able to bear the weight and/or afford a secure anchorage of the equipment may cause the unit to fall and/or topple, resulting in damage to persons or property, or to the unit itself. Make certain that every care

and precaution is taken when positioning and securing the unit.

If the unit is easily accessible to children, unauthorized persons or animals, this is a situation that can give rise to accidents and injuries, perhaps serious. Install the unit in a place where access is allowed only to authorized persons, or install barriers or guards preventing unauthorized entry.

GENERAL RISKS

A smell of burning, smoke or other indications of serious irregularity could signal the onset of situations liable to cause damage to persons or property or to the unit itself. Isolate the unit from the electrical power supply (red-and-yellow) switch.

Contact an authorized service centre so that the source of the problem can be identified and remedied.

Accidental contact with heat exchange coils, compressors, pressure pipelines or other components can result in wounding or burns, or both.

Always wear suitable clothing, including protective gloves, when working in the danger area.

Maintenance or repairs carried out by unskilled operatives can result in harm or damage to persons and property, or to the unit itself. Always contact an authorized service centre.

Failure to close the panels of the unit, or to check that all the fixing screws of the panels are properly tightened, can result in harm or damage to persons or property, or to the unit itself.

Verify periodically that all panels are closed and made properly secure.

In the event of fire, the temperature of the refrigerant can rise to the point that pressure will exceed safety levels and perhaps cause fluid to be projected. It may also happen that parts of the circuit isolated by closed valves will explode.

Do not stand near safety valves, and never leave the valves of the refrigerant circuit closed.

ELECTRICAL SYSTEM

If the power line connecting the unit to the a.c. supply is incomplete, or if the connection is made with cables of incorrect cross section and/or with insufficiently rated protective devices, this can result in electric shock, toxicity hazard, damage to the unit or fire.

All work on the electrical system should be carried out referring to the wiring diagram and to the directions given in this manual, and the system itself must be dedicated.

Failure to secure the cover enclosing electrical components can lead to the infiltration of dust and water, ultimately causing electric shocks, damage to the unit, or fire.

Always fasten the cover securely to the unit.

If live metal parts of the unit are not connected properly to the earth system, they can cause electric shock or even death by electrocution.

Make absolutely certain that the connection to the earth system is made in accordance with correct practice.

Contact with live parts rendered accessible internally of the unit when the guards are removed can result in electric shock, burns or death by electrocution.

Before exposing these parts, make certain the isolating switch on the power line to the unit is set to the OFF position and padlocked, and post a warning sign.

Contact with parts that could become live when the unit is started up can result in electric shock, burns or death by electrocution.

When there is no need for circuits to be powered up, set the isolating switch on the power line to the OFF position, padlock it and post a warning sign.

MOVING PARTS

Contact with the fan rotors can cause injury.

Before removing the protective grilles or the fans themselves, make certain the isolating switch on the power line to the unit is set to the OFF position and padlocked, and post a warning sign.

Before removing the protective grilles or the fans themselves, make certain the isolating switch on the power line to the unit is set to the OFF position and padlocked, and post a warning sign.

REFRIGERANT

In the event of safety valves coming into operation and releasing refrigerant gas, persons in the vicinity can be

injured or suffer toxic effects. Always wear suitable clothing and protective goggles when working in potential hazard areas.

In the event of refrigerant gas escaping, refer to the "Safety datasheet" for the particular refrigerant.

If an open flame or heat source is brought into contact with the refrigerant, or the pressurized gas circuit should overheat (e.g. during welding operations), this can cause explosion or fire. Do not position any heat source within the hazard area.

Maintenance or repair operations involving welding must be carried out with the system emptied of refrigerant.

WATER SYSTEM

Defects affecting pipelines, connections or valves and other control componentry can result in water being leaked or sprayed from the system, occasioning damage to property or causing short circuits in the unit.

Make certain all hydraulic connections are securely made, following the directions given in the present manual.

REFRIGERANT SAFETY CHARTS

01	Identifying elements for the substance	Product name: forane 134a N°SDS 00941 Supplier: ELF ATOCHEM ITALIA Via Degli Artigianelli 10, 20159 Milano tel. 02/668111
02	Information concerning composition of components	Chemical name of the compound 1.1.1.2 - tetrafluoroethane General name: halogenated hydrocarbon CAS: 811-97-2 EINECS: 212-377-0
03	Identification of risk	Effects on health: practically non-toxic Greatest physical and chemical dangers: Thermal decomposition in toxic and corrosive products
04	First-aid measures	Inhalation: Carry the victim into the open air. Resort to oxygen or artificial respiration if necessary. Contact with skin: Frostbite must be treated in the same way as burns. Contact with the eyes: Immediate rinsing in abundant water. Instructions for the physician: Do not administer catecholamine (due to the sensitisation provoked by the product)
05	Fire prevention measures	Specific dangers: Thermal decomposition into toxic and corrosive products. Hydrofluoric acid. Hydrochloric acid in gaseous form. Phosgene Carbon monoxides (CO). Specific means of intervention: Cool containers/cisterns with jets of water. Prevent any sparks or flames. Do NOT smoke. Special protection systems for fire-fighting squads: Carry breathing apparatus and wear protective clothing.
06	Measures to take in case of accidental spillage	Individual precautions: Avoid contact with the skin, eyes and inhalation of vapours. In an enclosed space: ventilate or use breathing apparatus (risk of suffocation). NO SMOKING ALLOWED. Remove all risk of sparks or flames.
07	Manipulation and storage	Manipulation: Technical measures/precautions. Form of storage and manipulation applicable to the products: PRESSURIZED GAS. Ensure adequate ventilation and evacuation for the level of equipment. Advice for use: Prevent sparks and contact with hot surfaces. DO NOT SMOKE.. Storage: Technical measures/Storage procedures: Store at room temperature in the original container. Keep away from flames, hot surfaces and sparks. Store in a cool, well-ventilated place. Protect full containers from sources of heat to avoid excessive pressures. Packing: Recommended: Ordinary steel, Stainless steel. Avoid: Alloy containing more than 2% magnesium. Plastics.
08	Control of individual exposure/protection	Precautionary measures to be taken: Ensure a sufficient exchange of air and/or suction in workplaces. Control parameters. Exposure limits: recommended by ELF ATOCHEM: VME = 1000ppm=4420mg/m ³ Individual protective equipment: Respiratory protection: In case of insufficient ventilation, carry suitable breathing apparatus. Protection for the hands: Gloves Protection for the eyes: Protective eyewear. Specific hygiene measures: avoid contact with the skin, eyes and inhalation of the vapours. DO NOT SMOKE.

09	Physical and chemical properties	<p>Physical state (20°C): liquid gas Colour: colourless Smell: Slightly similar to ether; pH: not applicable. Boiling point/interval: -26,4°C Melting point/interval: -101°C Flash point: No flare up at test conditions Self-ignition temperature: 743°C (1bar) 215°C (3bar) Vapour pressure: (25°C):0.665MPa (6.65bar) a (50°C):1.32MPa (13.2bar) a (70°C): 2.12MPa (21.2bar) Vapour density: (25°C): 4.26kg/m³ Density: (25°C): 1206kg/m³ a (50°C): 1102kg/m³ a (70°C): 996kg/m³ Solubility: water: (25°C): 0,9g/l Distribution coefficient: log Pow = 1.06 (n-octanole/water) Other data: Henry constant: 1.53Pa m³/mol Not dissociated in water Solubility of water in the product at 25°C: 0,097% in weight. Critical temperature: Tc=101°C Critical pressure. Pc=4.07MPa (40.7bar)</p>
10	Stability and reactivity	<p>Conditions to avoid: Avoid contact with flames and red-hot metal surfaces. Dangerous decomposition products: Thermal decomposition into toxic and corrosive products: hydrofluoric acid, hydrochloric acid in gaseous form, phosgene, carbon monoxide (CO) Other information: Stable product at ambient temperature. In presence of air the product can mix up into a flammable blend at particular temperature and pressure conditions.</p>
11	Toxicological information	<p>Acute toxicity: Inhalation: Practically non-toxic in experiments conducted on animals. CL50/inhalation/4 hrs/on rats>500000ppm As with other volatile aliphatic halogenated compounds, with the accumulation of vapours and/or the inhalation of large quantities, the product can cause: loss of consciousness and heart problems aggravated by stress and lack of oxygen; risk of death. Local effects: Contact with skin: Frostbite possible from splashes of liquefied gas. Practically non-irritating for skin in experiments conducted on animals (rabbits). Contact with the eyes: practically non-irritating for eyes in experiments conducted on animals (rabbits). Sensibilisation: Contact with skin: Experimental for the animal: No skin sensitizer (guinea pig). Chronic toxicity: Studies on animal protracted inhalation do not highlight any chronic toxic effect (rat/ years(s)/ Inhalation: 50000ppm) Specific effects: Genotoxicity according experimental available data NOT Genotoxic Carcinogenesis: experiments on animals do not highlight carcinogen effect clearly demonstrated (rat /Inhalation – for oral administration) Toxicity for reproduction: Foetal growth no toxic effect for foetal development (rat/rabbit/inhalation). Fertility, according the available data on animal: no toxic effects on fertility (rats/inhalation)</p>

This document refers to the product as is and which conforms to the specifications supplied by ELF ATOCHEM.

If combinations or mixtures are made, check that there are no new dangers resulting from this action. The information provided in this report has been provided in good faith and is based on our latest knowledge of the product in question as of the date of publication of the same. The attention of users is drawn to the potential risks of employing the product for any use other than that for which it is intended. This report must be used and reproduced solely for purposes of prevention and safety. The list of legislative, regulatory or administrative texts must not be considered exhaustive. The product user is under obligation to refer to all the official texts concerning the use, conservation and manipulation of the product for which he is sole responsible. The product user must also provide all those who might come into contact with the product with the information necessary for their safety at work and the protection of their health and that of the environment, giving them a copy of this safety information report.

RECEPTION

INSPECTION UPON RECEPTION

Check on arrival that the unit has not suffered damage during transit and that it is complete in every part as specified in the order. In the event of visible damage/deficiencies being discovered, make a note immediately on the delivery document with the comment: **CONDITIONAL ACCEPTANCE — CLEAR EVIDENCE OF DEFICIENCIES/DAMAGE DURING TRANSIT**

Inform both the supplier and the carrier of the details by fax and by registered mail with advice of receipt not later than 8 days after taking consignment. Notifications sent after 8 days have elapsed will be ignored.

STORAGE

Shelter from: direct sunlight, rain, sand and wind

Temperature: maximum 60°C minimum -10°C

Maximum humidity: 90%

The respect of the instructions on the exterior side of the packaging assures the physical and functional integrity of the unit for the final user's advantage.

It is recommended to:

- Handle carefully
- Keep in a dry place
- Avoid putting other objects on top of the unit (respect the limits of levels of superimposition shown in the package)
- Avoid placing the unit with thermoretractable protection under the sun since the pressure of the circuits can assume values which activate the safety valves.

HANDLING

The operation of handling the unit must be carried out respecting the instructions of the safety norms in force (Legislative Decree 626/94 and following modifications)

Before starting the handling operations:

- Value the critical points during handling (stairs, flights, disconnected routes, doors, etc)
- Verify that the lifting capacity of the means used is adequate to the unit weight
- Consider that the barycentre could be moved with respect to the center of the unit
- Before starting to lift, verify that the unit is at a stable balance

The following examples are indications; the choice of the means and of the handling modes will depend on factors, such as:

- The unit weight
- Type and overall dimensions of the unit
- Place and route for the handling (dirt yard, asphalted square, etc)
- Condition of the place of destination (roof, square, etc)
- Handling distance characteristics (distances, flights, steps, doors)

LABELS / YELLOW BRACKETS SHOW THE LIFTING POINTS

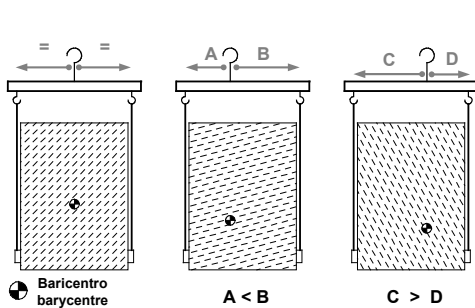

How to balance the charge

Move the upper hook or the lower hooks, according to the spring equalizer rocker arm type

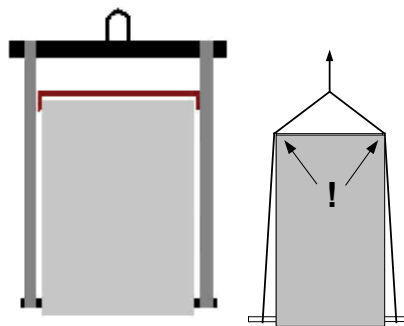

use a spacer bar to avoid damaging the unit

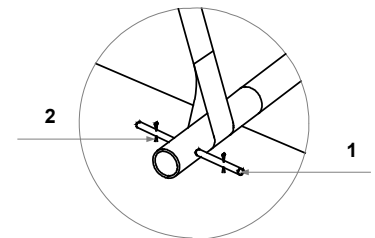

Insert safety pins (1)

and split pins (2)

HOISTING using a CRANE or SIMILAR.

- Slide the provided lifting pipes into the holes in the base of the unit.
- Position the ends of the pipes that protrude from the unit so that you can insert the provided shear pins into the proper holes.
- Fit the lifting belts over the pipes between the safety rods and the base of the unit (see drawing).
- Gradually bring the lifting belts under tension, making sure they are positioned correctly. Make sure the unit is always in steady equilibrium.
- Start hoisting the unit.

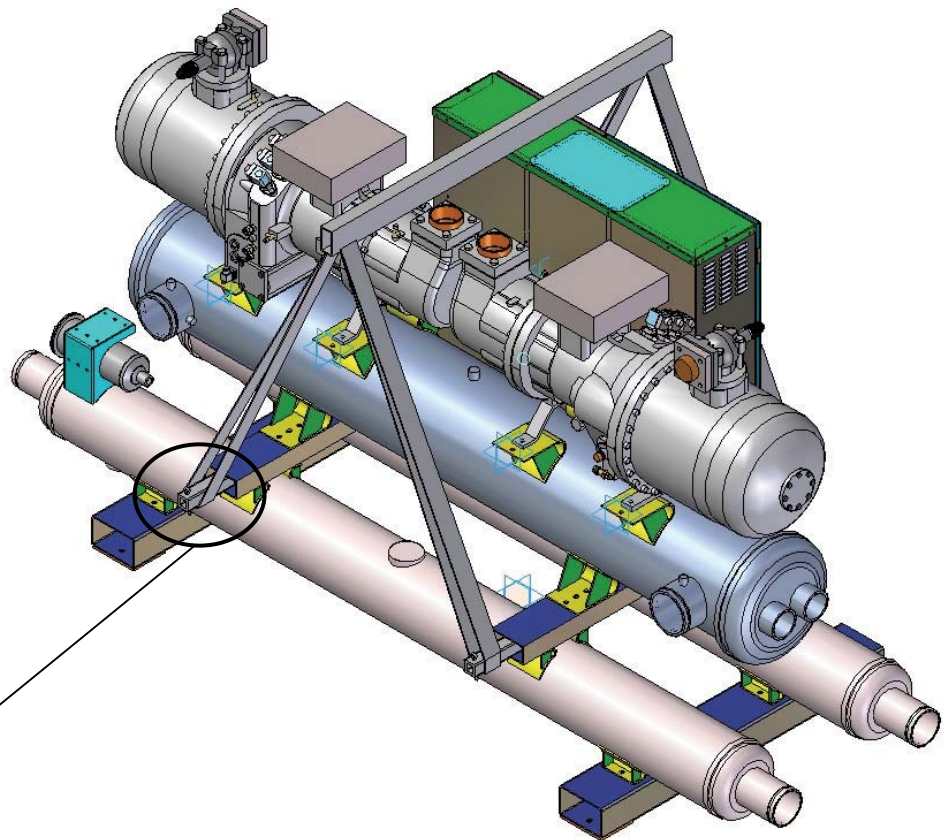

Split pin for belt

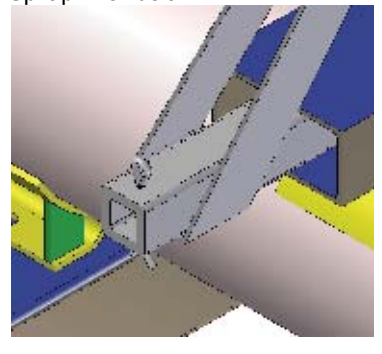

REMOVING THE PACKING

For removing the packaging, use specific personal protection for the operator (gloves, glasses, etc.).

While removing the packaging, pay attention not to damage the unit.

Check for any visible damage.

Dispose of the packaging by taking it to specialist collection or recycling centres in accordance with local regulations.

POSITIONING

GENERAL

For installing air-conditioning systems, it is necessary to consider the following:

- the technical spaces necessary for the machine and system
- the place where the machine will be installed
- the transport of thermal carrier fluids and relevant connections to the unit:
 - water
 - air
 - refrigerant (unit in more sections)
- electrical connections

If these aspects are not evaluated carefully, they can affect the performances and the working life of the unit.

FUNCTIONAL CLEARANCES

When placing the unit, please respect the functional clearances indicated in DIMENSIONS section.

The functional spaces need to be observed because of the following:

- to guarantee the good operation of the unit
 - to allow the performance of all maintenance operations
 - to protect the authorized operators and exposed people
- If more units are placed close to one another, the functional spaces must be doubled.

POSITIONING

1. The units are designed for **INDOOR** installations, performed in fixed positions and in areas accessible only to qualified and authorized personnel
2. **SAFETY VALVE** (only if present on the unit) : the installer is responsible for evaluating the opportunity of installing drain tubes, in conformity with the local regulations in force (EN 378)
3. Install the unit **raised** from the ground
4. avoid installations in places subject to **flooding**
5. Verify that the fixing/supporting points are level and suitable to support the **weight of the unit** (see the weight and the weights distribution)
6. It is recommended to put the unit on specific **antivibration devices**

Each support point of the unit sustains a different weight. Therefore, each anti-vibration device is sized for a specific support point, and can only be placed there. The anti-vibration devices must therefore be placed in accordance with the instructions provided with them and with the dimensional drawings in which the support points are indicated by W1 , W2 , W3 etc .

On each anti-vibration device (if provided by CLIVET), its identifying code is stamped, for example C6100100

Flexible joints are necessary on all the hydraulic/ aerualic connections (the joints are not supplied by Clivet)

INSTALLING ANTIVIBRATION MOUNTS

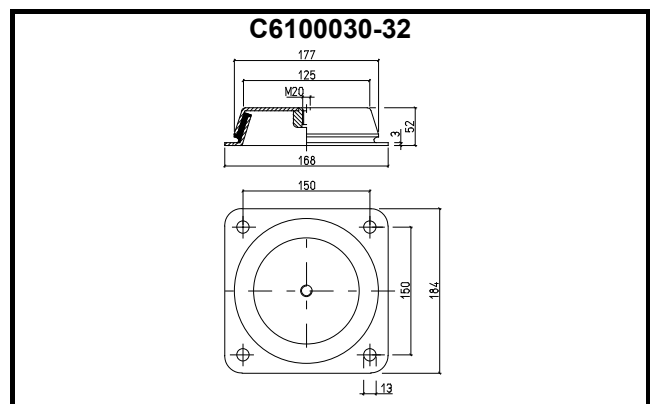
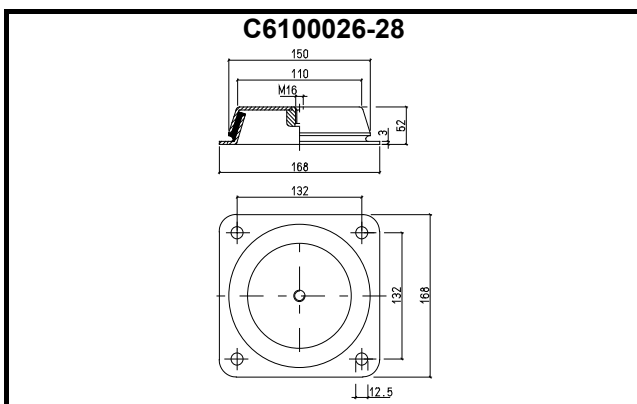

Table point of support / antivibration mount

CLASS A

Size	Compressor		W1	W2	W3	W4	Ant. mount code
2.160	Refcomp	ST	C6100026	C6100026	C6100028	C6100028	PE980005
		EN	C6100028	C6100028	C6100028	C6100028	PE980006
	Bitzer	ST	C6100026	C6100026	C6100028	C6100028	PE980005
		EN	C6100028	C6100028	C6100028	C6100028	PE980006
2.180	Refcomp	ST	C6100028	C6100028	C6100028	C6100028	PE980006
		EN	C6100028	C6100028	C6100028	C6100028	PE980006
	Bitzer	ST	C6100028	C6100028	C6100028	C6100028	PE980006
		EN	C6100028	C6100028	C6100028	C6100028	PE980006
2.220	Refcomp	ST	C6100028	C6100028	C6100028	C6100028	PE980006
		EN	C6100028	C6100028	C6100028	C6100028	PE980006
	Bitzer	ST	C6100028	C6100028	C6100028	C6100028	PE980006
		EN	C6100028	C6100028	C6100028	C6100028	PE980006
2.250	Refcomp	ST	C6100028	C6100028	C6100028	C6100028	PE980006
		EN	C6100028	C6100028	C6100028	C6100028	PE980006
	Bitzer	ST	C6100028	C6100028	C6100028	C6100028	PE980006
		EN	C6100028	C6100028	C6100028	C6100028	PE980006
2.280	Refcomp	ST	C6100028	C6100028	C6100028	C6100028	PE980006
		EN	C6100028	C6100028	C6100028	C6100028	PE980006
	Bitzer	ST	C6100028	C6100028	C6100032	C6100028	PE980020
		EN	C6100028	C6100028	C6100032	C6100032	PE980007
2.300	Refcomp	ST	C6100028	C6100028	C6100032	C6100028	PE980020
		EN	C6100032	C6100028	C6100032	C6100028	PE980007
	Bitzer	ST	C6100032	C6100028	C6100032	C6100028	PE980007
		EN	C6100032	C6100028	C6100032	C6100032	PE980025
2.320	Refcomp	ST	C6100028	C6100028	C6100032	C6100032	PE980007
		EN	C6100032	C6100032	C6100032	C6100032	PE960007
	Bitzer	ST	C6100032	C6100032	C6100032	C6100032	PE960007
		EN	C6100032	C6100032	C6100032	C6100032	PE960007
2.340	Refcomp	ST	C6100028	C6100028	C6100032	C6100032	PE980007
		EN	C6100032	C6100032	C6100032	C6100032	PE960007
	Bitzer	ST	C6100032	C6100032	C6100032	C6100032	PE960007
		EN	C6100032	C6100032	C6100032	C6100032	PE960007
2.360	Refcomp	ST	C6100028	C6100028	C6100032	C6100032	PE980007
		EN	C6100032	C6100032	C6100032	C6100032	PE960007
	Bitzer	ST	C6100032	C6100032	C6100032	C6100032	PE960007
		EN	C6100032	C6100032	C6100032	C6100032	PE960007
2.420	Refcomp	ST	C6100032	C6100032	C6100032	C6100032	PE960007
		EN	C6100032	C6100032	C6100032	C6100030	PE980032
	Bitzer	ST	C6100032	C6100032	C6100030	C6100030	PE960007
		EN	C6100032	C6100032	C6100030	C6100030	PE960009
2.450	Refcomp	ST	C6100032	C6100032	C6100032	C6100030	PE980032
		EN	C6100032	C6100032	C6100032	C6100030	PE980032
	Bitzer	ST	C6100032	C6100032	C6100030	C6100030	PE960009
		EN	C6100032	C6100030	C6100030	C6100030	PE980029
2.480	Refcomp	ST	C6100032	C6100032	C6100030	C6100030	PE960009
		EN	C6100032	C6100030	C6100030	C6100030	PE980029
	Bitzer	ST	C6100032	C6100032	C6100030	C6100030	PE960009
		EN	C6100032	C6100030	C6100030	C6100030	PE980029
2.540	Refcomp	ST	C6100032	C6100032	C6100030	C6100030	PE960009
		EN	C6100030	C6100030	C6100030	C6100030	PE960008
2.600	Refcomp	ST	C6100032	C6100032	C6100030	C6100030	PE960009
		EN	C6100030	C6100030	C6100030	C6100030	PE960008

CLASS B

Size	Compressor		W1	W2	W3	W4	Ant. mount code
2.160	Refcomp	ST	C6100026	C6100026	C6100026	C6100026	PE980003
		EN	C6100028	C6100028	C6100028	C6100028	PE980006
	Bitzer	ST	C6100026	C6100026	C6100026	C6100026	PE980003
		EN	C6100028	C6100028	C6100028	C6100028	PE980006
2.180	Refcomp	ST	C6100026	C6100026	C6100026	C6100026	PE980003
		EN	C6100028	C6100028	C6100028	C6100028	PE980006
	Bitzer	ST	C6100026	C6100026	C6100026	C6100026	PE980003
		EN	C6100028	C6100028	C6100028	C6100028	PE980006
2.220	Refcomp	ST	C6100028	C6100028	C6100028	C6100028	PE980006
		EN	C6100028	C6100028	C6100028	C6100028	PE980006
	Bitzer	ST	C6100028	C6100028	C6100028	C6100028	PE980006
		EN	C6100028	C6100028	C6100028	C6100028	PE980006
2.250	Refcomp	ST	C6100028	C6100028	C6100028	C6100028	PE980006
		EN	C6100028	C6100028	C6100028	C6100028	PE980006
	Bitzer	ST	C6100028	C6100028	C6100028	C6100028	PE980006
		EN	C6100028	C6100028	C6100028	C6100028	PE980006
2.280	Refcomp	ST	C6100028	C6100028	C6100028	C6100028	PE980006
		EN	C6100028	C6100028	C6100028	C6100028	PE980006
	Bitzer	ST	C6100028	C6100028	C6100028	C6100028	PE980006
		EN	C6100028	C6100028	C6100028	C6100028	PE980006
2.300	Refcomp	ST	C6100028	C6100028	C6100028	C6100028	PE980006
		EN	C6100028	C6100028	C6100028	C6100032	PE980020
	Bitzer	ST	C6100028	C6100028	C6100028	C6100032	PE980020
		EN	C6100028	C6100028	C6100032	C6100032	PE980007
2.320	Refcomp	ST	C6100028	C6100028	C6100028	C6100032	PE980020
		EN	C6100028	C6100028	C6100032	C6100032	PE980007
	Bitzer	ST	C6100028	C6100032	C6100032	C6100032	PE980025
		EN	C6100032	C6100032	C6100032	C6100032	PE960007
2.340	Refcomp	ST	C6100028	C6100028	C6100032	C6100032	PE980007
		EN	C6100028	C6100028	C6100032	C6100032	PE980007
	Bitzer	ST	C6100032	C6100032	C6100032	C6100032	PE960007
		EN	C6100032	C6100032	C6100032	C6100032	PE960007
2.360	Refcomp	ST	C6100028	C6100028	C6100032	C6100032	PE980007
		EN	C6100028	C6100028	C6100032	C6100032	PE980007
	Bitzer	ST	C6100032	C6100032	C6100032	C6100032	PE960007
		EN	C6100032	C6100032	C6100032	C6100032	PE960007
2.420	Refcomp	ST	C6100028	C6100028	C6100032	C6100032	PE980007
		EN	C6100032	C6100032	C6100032	C6100032	PE960007
	Bitzer	ST	C6100032	C6100032	C6100032	C6100032	PE960007
		EN	C6100032	C6100032	C6100032	C6100032	PE960007
2.450	Refcomp	ST	C6100028	C6100028	C6100032	C6100032	PE980007
		EN	C6100032	C6100032	C6100032	C6100032	PE960007
	Bitzer	ST	C6100028	C6100028	C6100032	C6100032	PE980007
		EN	C6100032	C6100032	C6100032	C6100032	PE960007
2.480	Refcomp	ST	C6100032	C6100032	C6100032	C6100032	PE960007
		EN	C6100032	C6100032	C6100030	C6100030	PE960009
	Bitzer	ST	C6100032	C6100032	C6100032	C6100032	PE960007
		EN	C6100032	C6100032	C6100030	C6100030	PE960009
2.540	Refcomp	ST	C6100032	C6100032	C6100032	C6100032	PE960007
		EN	C6100032	C6100032	C6100030	C6100030	PE960009
2.600	Refcomp	ST	C6100032	C6100032	C6100030	C6100030	PE960009
		EN	C6100032	C6100030	C6100030	C6100030	PE980029

WATER CONNECTIONS

GENERAL

Piping must be designed with the least possible number of bends and head variations. If the pressure chute of the installation is above the useful prevalence of the pump, the water delivery capacity is reduced as well as, as a consequence, the thermal exchange and the yield.

INTERCEPTING VALVES

Install on the input and output of the user parts (exchangers, coils, humidifiers, etc) So that it will be possible to carry out all the service operations and possible substitutions without emptying the installation.

PRESSURE AND TEMPERATURE INDICATOR

Install on the input and output of the user parts (exchangers, coils, humidifiers, etc) So that it will be possible to carry out all the service operations.

AUTOMATIC OR MANUAL ESCAPE VALVES

Install the highest points of tubes in a way that the air can escape form the circuit.

BLEEDING COCK

Install them at the lowest points of the circuit, so as to allow emptying.

LEAKAGE TESTS

Before performing the insulation of the tubes, carry out a leakage test.

TUBE INSULATION

All tubes of water must be insulated so that to avoid the formation of condensation and thermal dispersions along the tubes themselves. Verify that the insulation is the vapour coil type. The connections for the air escape and for the emptying must be out of the insulating thickness to assure the accessibility.

CONNECTIONS SUPPORTS

The weight of the hydraulic connections must be supported in the exterior of the unit so as not to stress the connections of user devices (exchangers, coils, humidifiers, etc) .

ANTI-VIBRATION DEVICES

In case of units with anti-vibration devices, it is necessary to assemble elastic joints, even on water connections.

RISK OF FREEZE

If the unit and the relevant water connections are subject to temperatures near 0°C:

- mix the water of the system with glycol
- protect the tubes with heating cables under the tubes insulation
- empty the system by verifying that:
 - no taps are closed so they can not trap the water, even after emptying
 - there are no low points where the water can stagnate even after emptying; blow if necessary

INSTALLATION EMPTYING

The refilling of the water present in the installation increase the oxidation phenomena and lime deposits.

If necessary empty only the interested system section and anyway empty or refill the installation if necessary .

EXPANSION TANK

The installation must be kept at the right pressure by both an expansion tank and a combined valve of pressure reduction and discharge; if the components are present on the unit, they must be installed on the installation. The expansion tank must be dimensioned in function of the water in the installation.

MAX. WORKING PRESSURE

10,5 bar evaporator
16 bar condenser

ARIES EFFECTS AND AIR BUBBLES CAN PRODUCE THE OVERCOMING AND CAUSE WATER DROPS.

EXCHANGER USE SIDE

FILTER

It is very important for the water to be free of impurities. If it is not, the efficiency of thermal exchange is diminished. In worst cases, the exchanger can be irreparably damaged. If the filter is not present on the machine, it must be immediately installed upstream from the unit, in a position which can be easily reached for cleaning.

The filter mesh must be :

- < 1 mm unit with 1 compressor
- < 1.5 mm multicompressor unit.

FLOW SWITCH

The flow switch must be present as a component of the system, so as to ensure shutdown of the unit if water is not circulating. It must be installed in a straight tract of the tubes, not near the elbows, which can generate harmful turbulence

UNFREEZABLE LIQUIDS

If the unit is used when the water temperature is lower than + 4°C, avoid the formation of ice by using unfreezable liquids (ex. Ethilenic Glycol) in the necessary percentage. The use must also be determined for ambient temperatures near 0°C .

ANTIFREEZE RESISTANCES

If the unit is equipped with antifreeze resistances on the exchanger side (standard or optional according to the models), verify that they are electrically fed during periods that the machine is stopped (night, weekends, long stops)

WASHING THE SYSTEM

Carefully wash the system by using clean water and discharge it before connecting the unit.

DIAGRAM OF RECOMMENDED USE SIDE CONNECTION

Depending on the type of machine and the selected setup, some components may be integrated into the unit.

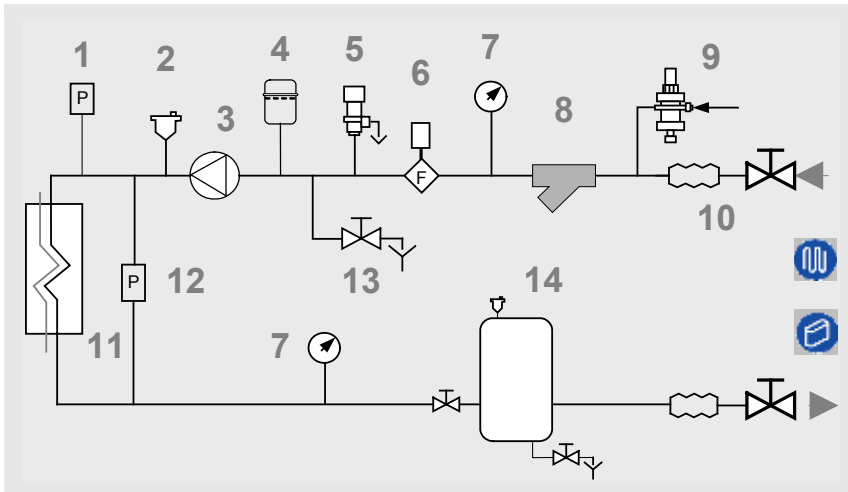

1. Charged system pressure switch
2. vent
3. circulating pump / pump
4. expansion tank
5. safety valve
6. flow switch
7. pressure switch / thermometer
8. filter
9. filling valve
10. antivibration joints
11. user side exchanger
12. Differential pressure switch
13. Discharge cock
14. inertial storage tank

The accumulation tank is necessary in the event of the following:

- the water in the system is very low
- the unit will not be used in a private house (in an industrial process or other)

RECOVERY EXCHANGER

OPTIONAL - The unit can be equipped with exchangers to recover the condensation heat.

The recovery can be:

TOTAL

- with 100% recovery of the condensation heat
- the thermoregulation is performed by CLIVET control system

PARTIAL

- with 20% recovery
- The customer is responsible for the management of the circulation pump, valves, thermostats, etc

The recovery input water must not be below 25°C, in the event that, wrongful operations and breakages of the unit can occur .

Water connections must be performed carefully as for the evaporator (filter, circuit washing, etc) .

Perform all necessary interventions to avoid the RISK OF FREEZING (tubes insulation, emptying of circuit, addition of glycol, anti-freeze resistances) .

Water temperature can reach high temperatures (up to 100°C), therefore:

- avoid the RISK OF BURNS by adopting the necessary precautions (insulation of tubes, temperature detecting station on water if the sanitary use is foreseen, etc)
- Install safety valves and specifically dimensioned expansion tanks in the hydraulic circuit.

VICTAULIC CONNECTIONS

1. Take away the supplied connection union by acting on the connection joint Victaulic.
2. Weld the union to the installation pipe.
3. Perform the connection between the installation pipe and the evaporator, using the joint.

Do not weld the system pipe with the Victaulic connection joint attached.

The rubber gasket might be irreparably damaged

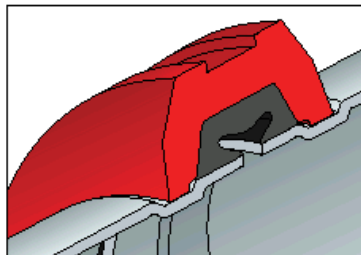

RECOMMENDED SOURCE SIDE CONNECTION SCHEMA

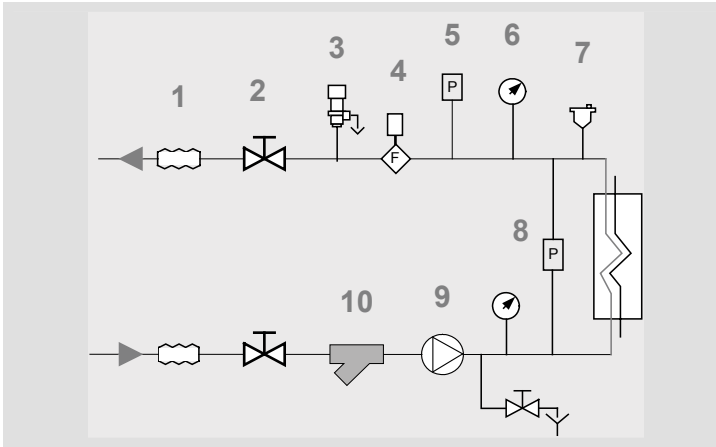

1. Antivibration joints
2. Shut-off valve
3. Safety valve
4. Flow switch
5. System min. pressure manostat
6. Pressure switch / thermometer
7. vent
8. Differential pressure switch
9. Pump
10. Filter

EVAPORATIVE COOLING TOWER

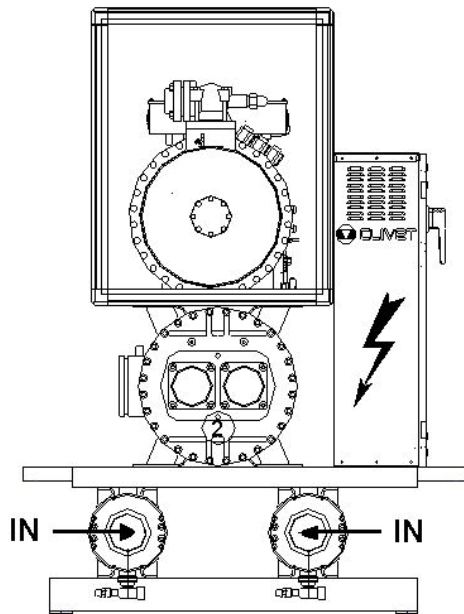

WELL

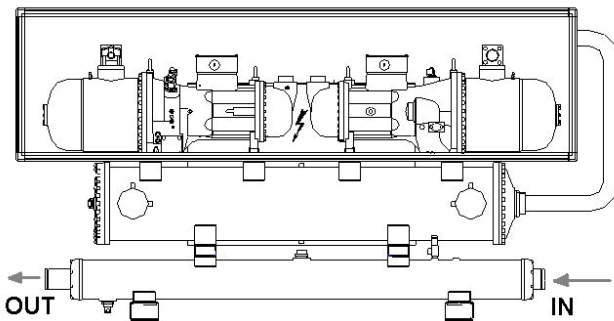
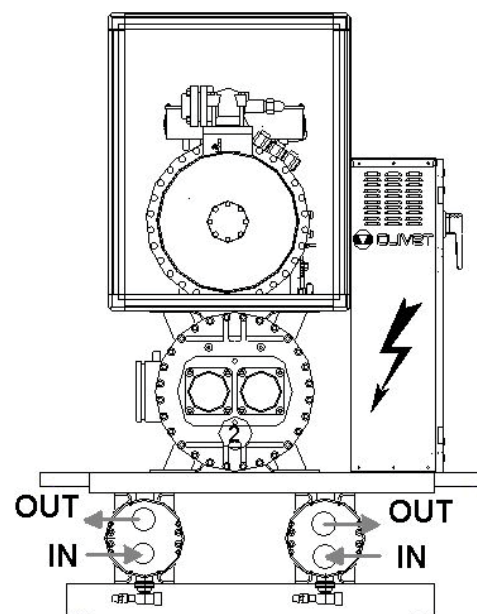

SYSTEM MEASURES ON SOURCE SIDE

FILTER

It is very important for the water to be free of impurities. If it is not, the efficiency of thermal exchange is diminished. In the worst cases, the exchanger can be irreparably damaged. The filter, if not present on-board the machine, must be installed immediately upstream from the unit, in a position that is easily accessible for cleaning

FLOW SWITCH

Since it is a system component, it must always be included, in order to ensure unit shutdown in the event of failure of water circulation. It is to be installed in a straight section of the pipes, and not near curves which generate harmful turbulence.

ANTI-FREEZE SOLUTIONS

For use of the unit with ambient temperatures near 0°C, use antifreeze solutions such as ethylene glycol to prevent the formation of ice. Its use is also required when geothermal probes are used.

SYSTEM WASHING

Before connecting the unit, carefully wash the system by filling it and emptying it several times with clean water.

CONTROL OF FLOW RATE

This makes it possible to limit water consumption, increase energy efficiency and extend the unit's operating limits. It can be modified by using

1. Modulating motorized valve
2. Cut-off valve
3. Pressure switch valve

CUT-OFF VALVE

This allows cut-off of water on the source side whenever the compressor is not running.

It is therefore advisable for systems with disposable water, if there is no modulating valve

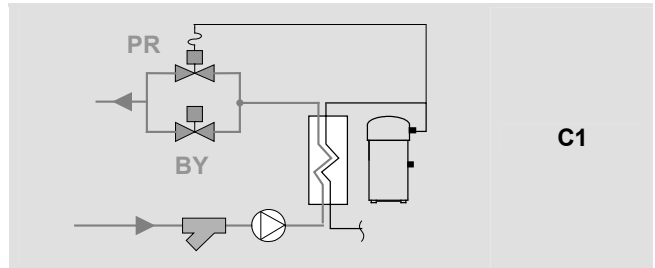

C1

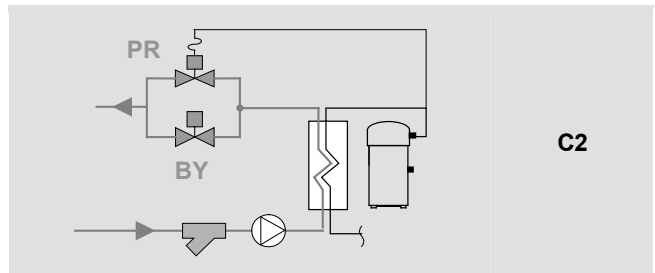

C2

BT3-BT4 TEMPERATURE PROBES OF WDHH UNIT

These probes, with respective connection, are supplied with the unit and they must be fitted as specified in the drawing.

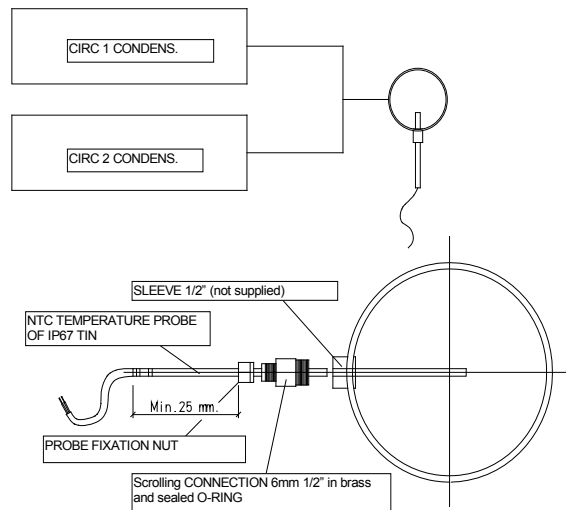

ELECTRICAL CONNECTION

GENERAL

The characteristics of the electrical lines and relevant components must be determined by SPECIALIZED PERSONNEL ABLE TO DESIGN ELECTRICAL INSTALLATIONS; moreover, the lines must be in conformity with professional procedures and the regulations in force.

All electrical operations should be performed by trained PERSONNEL HAVING THE NECESSARY REQUISITES UNDER LAW and being informed about the risks relevant to these activities.

Before performing any operation on the electrical system, make sure that the unit supply line is SELECTED AT START.

The earth connection must be made prior to other electrical connections.

For all electrical type operations, REFER TO THE ELECTRICAL DIAGRAM ATTACHED TO THE UNIT; the number of the diagram is shown on the registration plate positioned on the electrical board or next to it.

The electrical diagram should be carefully kept together with this manual and should be AVAILABLE FOR FUTURE INTERVENTION ON THE UNIT.

LINE OF UNIT POWER SUPPLY

The ELECTRICAL DATA OF THE UNIT are shown in the technical chart of this manual and on the unit registration plate. The presence of accessories can vary according to the unit; the electrical data shown in the technical chart

refer to standard units. In the event of differences between the data of the registration plate and the data shown in this manual, as well as in the technical chart, please refer to the DATA SHOWN IN THE REGISTRATION PLATE.

The protection device of the unit power supply line should break off the short circuit power whose value should be determined according to the plant features.

The section of supply cables and protection cable must be seized according to the characteristics of the protections used.

SIGNALS / DATA LINES

Do not overpass the maximum power allowed, which varies, according to the type of signal.

Lay the cables far from power cables or cables having a different tension and that are able to emit electromagnetic disturbances.

Do not lay the cable near devices which can generate electromagnetic interferences.

Do not lay the cables parallel to other cables; cable crossings are possible, only if laid at 90°.

Connect the screen to the ground, only if there are no disturbances

Assure the continuity of the screen during the entire extension of the cable.

Observe, if any, the requirements about impendancy, capacity, attenuation

STANDARD UNIT ELECTRICAL DATA

Acoustic configuration: Standard (ST) / extremely low noise (EN) / Energy efficiency: Efficiency class A

Sizes		2.160	2.180	2.220	2.250	2.280	2.300	2.320	2.340	2.360	2.420	2.450	2.480	2.540	2.600
F.L.A. FULL LOAD CURRENT AT MAX ADMISSIBLE CONDITIONS															
F.L.A. - Total	A	263	292	326	392	428	452	476	510	544	650	680	710	823	933
F.L.I. FULL LOAD POWER INPUT AT MAX ADMISSIBLE CONDITION															
F.L.I. - Total	kW	157	176	200	240	262	279	295	319	342	402	420	438	494	562
M.I.C. MAXIMUM INRUSH CURRENT															
M.I.C. - Value	A	627	641	683	808	879	650	674	703	737	911	975	1005	1474	1529

voltage unbalance: max 2 %

power supply: 400/3/50 Hz +/-6%

Acoustic configuration: Standard (ST) / extremely low noise (EN) / Energy efficiency: Efficiency class B

Sizes		2.160	2.180	2.220	2.250	2.280	2.300	2.320	2.340	2.360	2.420	2.450	2.480	2.540	2.600
F.L.A. FULL LOAD CURRENT AT MAX ADMISSIBLE CONDITIONS															
F.L.A. - Total	A	263	292	344	382	431	463	496	527	559	592	642	748	823	933
F.L.I. FULL LOAD POWER INPUT AT MAX ADMISSIBLE CONDITION															
F.L.I. - Total	kW	157	176	213	236	269	294	318	337	356	377	402	443	494	562
M.I.C. MAXIMUM INRUSH CURRENT															
M.I.C. - Value	A	627	641	490	552	577	590	622	701	733	839	916	1250	1474	1529

voltage unbalance: max 2 %

power supply: 400/3/50 Hz +/-6%

CONNECTION TO THE MAINS

1. Make sure that the sectioning device at the beginning of the unit's power line is opened, locked and equipped with a signal.
2. Open the general line disconnecting switch (if present)
3. Verify that the net is in conformity with the data shown in the registration plate placed on the electrical board.
4. Check the dimensional drawing for the input of the electrical lines
5. Take away the closing plate placed on the electric board (ONLY IF PRESENT) and drill a hole through it to pass the cables through)
6. Protect the cables, using the fairlead of an adequate size.
7. Using the layout of the electrical diagram, single out the connecting terminals of the electrical supply cables, of the neutral (if foreseen) and the PE protection cable
8. Connect the cables to the relevant terminal boards
9. Before supplying power to the unit, make sure that all the safety devices that were removed during electrical connections are positioned again.

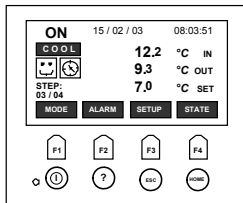

Use voltage-free remote control devices that are suitable to commute very low loads (12V, 10mA)

Few inputs must be activated by configuration parameters whose access is reserved to authorized assistance centers (in order to avoid unauthorized modifications)

ON / OFF FROM REMOTE CONTROL

It allows the remote start and stop, not by keypad.

It can be used to disable the unit during the night, the weekend etc., so with ON or OFF periods relatively longs (some hours).

It has not to be used with ON or OFF cycles too much shorts: they compromise the operating logic and they can cause malfunctions or faults. In summer operating, for example, ON –OFF cycles lower than one hour can compromise the thermoregulation logic, that implements an integral check.

If this function is not used, jump the respective terminals .

SIGNALIZATION OF MALFUNCTIONING/ UNIT FUNCTIONING

Remote signalization of the proper function (ex. green light) or signalization of blocks of the machine (ex. red light).

Maximum voltage at the terminal ends is 24v ac and maximum power is 1A

SECOND SET-POINT

It allows the use of a secondary set-point, such as, for example, for a night operation, which can be activated by a remote contact.

When the contact is CLOSED, the secondary set-point is activated .

DEMAND LIMIT

It allows one to temporarily limit the electric power absorbed by the unit, according to a 10 vcc or 4-20 mA external signal. The higher the signal is, the lower the number of compressors available to meet the thermal need.

The parameters must be configured by the assistance center .

MENU	NUM	Parameter name	meaning
thermoregulation-demandlimit	7	DmandLimitEn	Enables the function : <ul style="list-style-type: none"> • 0= disabled • 1=by signal • 2=by parameter
parameter-set-sensors	82	TypeDI	Type of signal : 0=0-10 V ; 1=4-20mA

MODULATING MOTORIZED VALVE

It allows to modulate the water flow-rate source side according to its temperature .

0-10V signal, see wiring diagram .

EXTERNAL AIR TEMPERATURE PROBE - Optional

It allows the automatic correction of the set-point according to the external air temperature.

For example, the summertime with low external temperatures, it is possible to have the internal comfort even with set-points higher than the standard.

The parameter configuration is necessary.

MENU	NUM	Parameter name	meaning
parameter control compext	1	EnCompExt	External compensation enabling 0 = no; 1 = COOL only; 2 = HEAT only; 3 = always
	4	MaxCExtC	Max. ext. compensation value of cooling
	5	MaxCExtH	Max. ext. compensation value of heating
	93	CextMaxH	Max. ext. temp. of heating compensation
	94	CextMinH	Min. ext. temp. of heating compensation
	106	CextMaxC	Max. ext. temp. of cooling compensation
	107	CextMinC	Min. ext. temp. of cooling compensation
parameter-set-sensors	9	ProbeText	It enables ext. temp. probe: 0=yes ; 1=non
SUMMER			WINTER

EXTERNAL AIR HUMIDITY PROBE - Optional

It allows the automatic correction of the set-point, according to external air enthalpy .

Nel funzionamento invernale la correzione avviene sulla sola temperatura.

The working process is similar to the above mentioned process .

The parameter configuration is necessary.

MENU	NUM	Parameter name	meaning
parameters thermoregulation compext	4	MaxCExtC	Max. Summer correction value
	110	HexMinC	Min. correction ext. enthalpy
	111	HexMaxC	MAX. correction ext. enthalpy
parameter-set-sensors	23	ProbeURExt	Enables external humidity probe: 1=YES / 0=NO

WATER RESET - Opzionale

It allows the automatic correction of the set-point, according to an external signal of 4-20 mA or 0-10 vcc.

The working process is similar to the above mentioned process .

The parameter configuration is necessary .

MENU	NUM	Parameter name	meaning
parameter control waterreset	11	MaxCWRC	WR Summer correction max. value
	24	MaxCWRH	WR Winter correction max. value
	75	WaterReset	Water Reset enabling: 0 = no; 1 = COOL only; 2 = HEAT only; 3 = always
	102	SWRMaxH	Winter MAX correction signal
	104	SWRMinH	Winter MIN correction signal
	105	SWRMaxC	Summer MAX correction signal
	108	SWRMinC	Summer MIN correction signal
parameter-set-sensors	83	TypeWR	Inlet signal type: 0=0-10V; 1=4-20mA

SUMMER

WINTER

CLIVET TALK MODULAR SYSTEM COMPOSITION

CLIVET TALK system is made up of different modules connected to each other with the CAN OPEN protocol.

The system configuration varies according to the typology of the unit and of the accessories: not always the represented electric modules are all presents on the unit .

	<p>INTERFACE code C5110821</p> <p>The interface module allows for the control of the operations of the whole machine, the programming of the different adjustment parameters and also to display the alarms and the unit status.</p>
	<p>CENTRAL MODULE code C5110694</p> <p>The central module manages the system configuration, the working mode, the set point, the thermal adjustment, remote inputs.</p>
	<p>SCREW COMPRESSOR MODULE code C5110801</p> <p>It manages the cooling circuit (compressors, fans, valves) and relative safety devices.</p>
	<p>COMPRESSOR MODULE - TANDEM / TRIO code C5110804 (tandem) – C5110801 (trio)</p> <p>It manages the cooling circuit (compressors, fans, valves) and relative safety devices.</p>

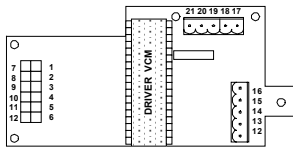

ELECTRONIC THERMOSTATIC EXPANSION VALVE MODULE

code C5110802

This manages the electronic thermostatic valve and the relative sensors for control of temperature/pressure.

It is installed above the compressor module

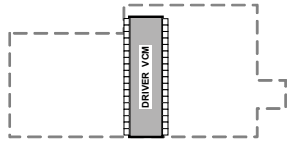

DRIVER MODULE

code C5110803

The electronic thermostatic valve management firmware is located here. It is mounted on the expansion module.

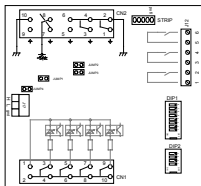

EVAPORATOR MODULE

code C5110674

It manages components, safety devices, inputs and outputs relative to the water circuit (pumps, differential manostat, temperature probes)

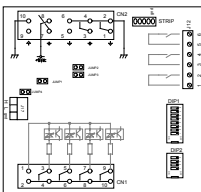

PUMP MODULE

code C5110701

It manages controls and safety devices relative to the circulation pumps

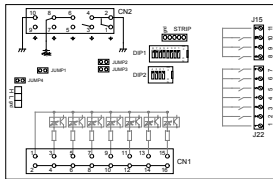

RECOVERY MODULE

code C5110679

It manages the electrovalves and the pumps relative to the recovery circuit.

REMOTE TERMINAL

cod PE1W0005

The remote keyboard has the same functions of the keyboard on board of the machine.

The connection of the remote keyboard to the system on board of the machine is carried out, using the "CAN to CAN" converter, which must be placed in the electric board of the machine

The REMOTE KEYBOARD must be configured with the software address = 27 (only an authorised service centre can perform this operation).

If the unit is managed by timetables, they must be activated only on one of the two keyboards of the machine, better if the remote keyboard.

CONNECTIONS: refer to the electric diagram and to the SIGNAL/DATA LINES paragraph.

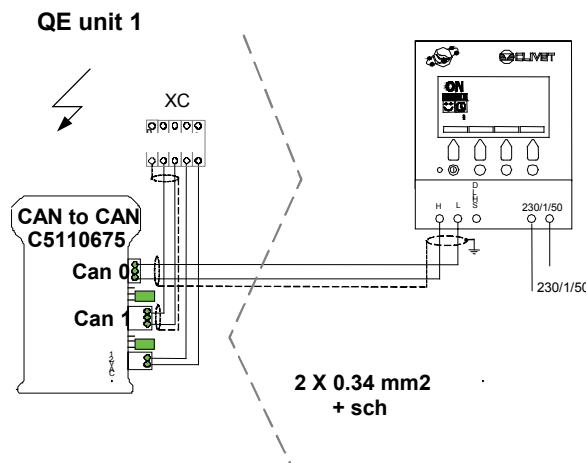

MODBUS - CONVERTER CAN TO MODBUS VIA RS 485

Interfacing via RS 485 is performed using a converter for each unit.

The converter must be mounted on the electric board of the unit and connected, following the electric diagram attached to the unit.

CONNECTIONS: refer to the electric diagram and to the SIGNAL/DATA LINES paragraph

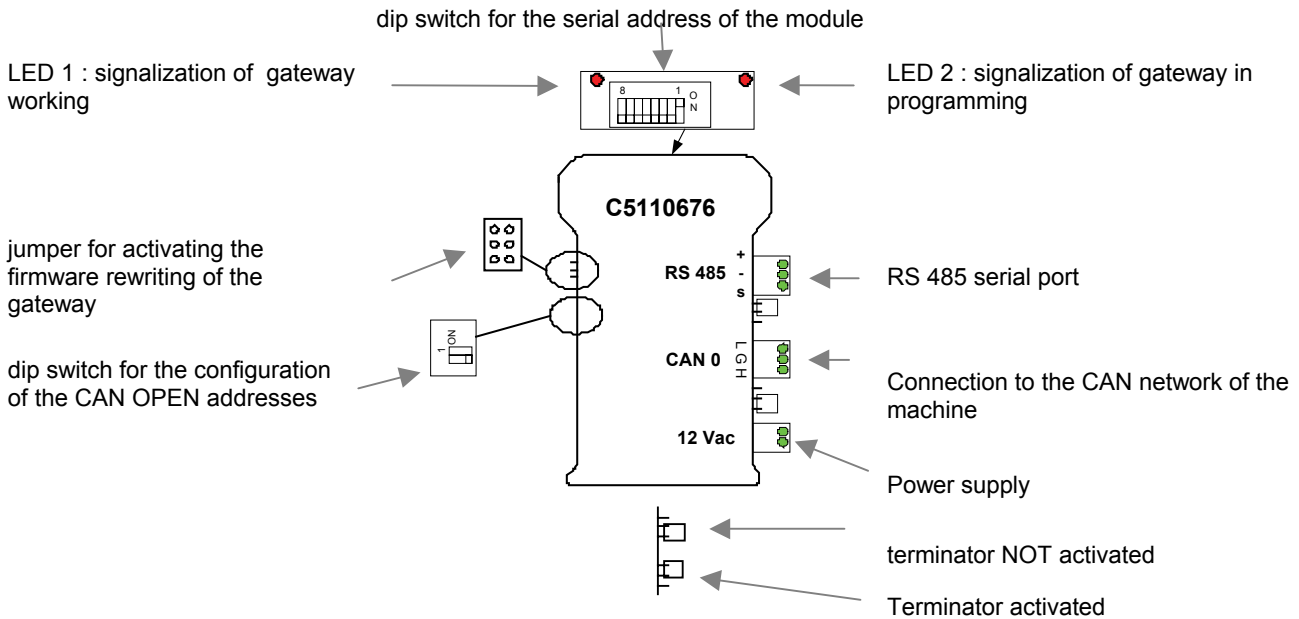

UNIT NETWORK – MINI NETWORK – MASTER SLAVE

The *CLIVET TALK Local Network* system allows to connect up to 6 machines in a network which all serve the same installation.

To interact with the network which controls the working of the system, it is necessary to have a CAN to CAN converter code C5110692 for each machine.

Each single machine is equipped with the standard electronic devices: if necessary, it can function as an independent unit.

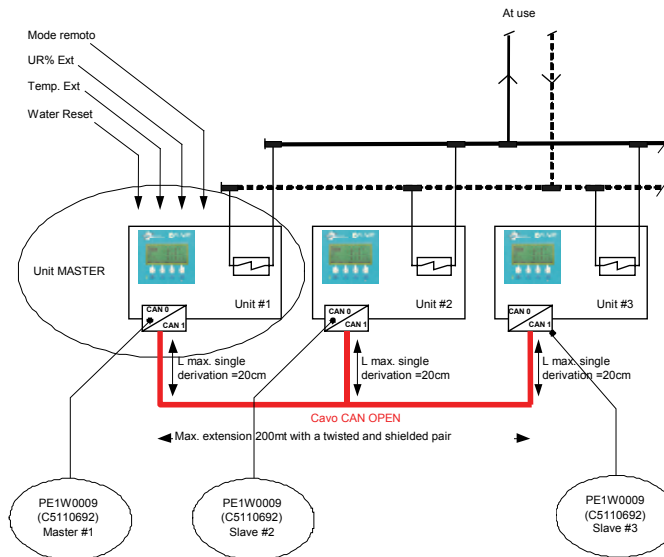

CONNECTION CABLE :

Section (nominal)	0.34mm ²
Heater	70mΩ/meter
Impedance	120mΩ/meter
Propagation delay	5nS/meter
Length MAX	200meters

DATALOGGER - cod PE1W0006

CONNECTIONS : make reference to the electrical panel and to SIGNALS/DATA LINES paragraph

KIT LONWORKS

Upon request, the unit is equipped with the kit already mounted on the electric board; it can eventually be mounted later. Refer to the electric diagram and to the LONWORKS MANUAL. For information about cables for the Lonworks network, visit the web site www.echelon.com.

LONWORKS technology is a complete platform to implement the network system control. These networks consist of intelligent control instruments, or *nodes*, which interact with their environment and communicate to each other by using a common message based on the (*LonTalk*®) protocol. A LONWORKS network can have up to 32,385 nodes subdivided into 255 sub-networks (127 nodes/sub-network).

The Gateway device is already configured, according to the Echelon classification for the type of the unit it is designed for, with a number of managed variables, which is a sub-array of those managed originally by the machine and able to accept the Echelon standard profiles. The supply of this device does not include the activity of configuration and management of the LonWorks network to which it is connected; as usual, they are supplied by the Supervision System supplier.

CAN TO MODBUS

GATEWAY LON-WORKS

Signalization led of gateway in programming

Dip switch for setting the module serial address

Signalization led of gateway operation

jumper to activate the gateway firmware rewriting

terminator INSERTED

Dip switch configuration of CAN OPEN addresses

Terminator NOT ACTIVATED

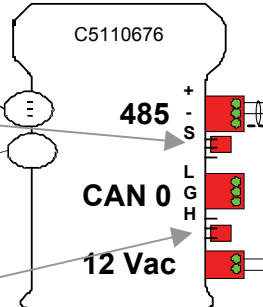
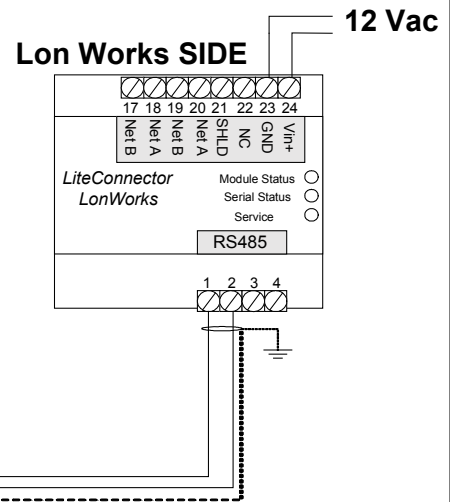

START-UP

ALL THE EQUIPMENT MUST BE COMMISSIONED BY AUTHORISED SERVICE CENTRES.
THIS SERVICE IS LIMITED TO START-UP OF THE UNIT ONLY AND NOT THE CONNECTIONS OR INSTALLATION OF THE SYSTEM.

ONLY QUALIFIED TECHNICIANS MUST PERFORM THE FOLLOWING OPERATIONS.

PRELIMINARY CHECKS

Before checking, please verify the following

1. the unit should be installed properly and in conformity with this manual.
2. the electrical power supply line should be sectioned at the beginning.
3. the sectioning device is locked and the proper warning "not to operate" sign is placed on the handle.
4. make sure no tension is present

REFRIGERANT SYSTEM

Carefully check the refrigerating circuit: the presence of oil stains can mean leakage caused by transportation, movements or other).

Open the cocks of the refrigerator circuit, if there are any.

Using the unit manometers, if present, or service manometers, verify that the refrigerating circuit is in pressure.

Make sure that all the service outlets are closed with proper caps; if caps are not present a leak of refrigerant can be possible.

WATER SYSTEM

Ensure that the plumbing system has been washed. Drain the wash water before connecting the unit to the system.

Check that the water circuit has been filled and pressurised.

Perform a seal check at max. working pressure checking that no leaks are present.

Check that the shut-off valves in the circuit are in the "OPEN" position.

Check that there is no air in the circuit. If required, bleed it using the vent valves in the system.

Check that there are no ARIES EFFECTS in the transient (pump and / or valve activation/deactivation)

When using antifreeze solutions, make sure the glycol percentage is suitable for the type of use envisaged.

% weight of ethylene glycol	10 %	20 %	30 %	40 %
Freezing point	- 4 °C	- 9 °C	- 15 °C	- 23 °C
Safety temperature	- 2 °C	- 7 °C	- 13 °C	- 21 °C

VERIFY TENSIONS – ABSORPTIONS

Check that the temperatures of the fluids are included in the WORKING LIMITS.

If the controls of the previous paragraphs are positive, it is possible to restart the unit.

For information on the control panel, refer to the paragraph CONTROL.

While the unit is working (ATTENTION ELECTRIC RISK: WORK SAFELY) check:

- Power supply tension
- Phase unbalance
- Total absorption of the unit
- Absorption of the single electric loads

Check that the circulator pumps are not blocked. In fact, their motor shaft may seize up, especially after long shutdowns. Unblocking can be accomplished with a screwdriver using the purge hole.

ELECTRICAL SYSTEM

Check the proper tightening of the screws that fix the conductors to the electrical components in the board (during handling and transportation, the vibrations could have loosened them).

Verify that the unit is connected to the ground plant.

Control that all panels and protection devices of the unit are repositioned and blocked.

Charge the unit by closing the sectioning device, but leave it on OFF.

Make sure that the tension and net frequency values are within the limit of:

230 +/- 6% single phase unit; 400/3/50 +/- 6% three-phase unit

Control the unbalancing of the phases: it must be lower than 2% .

Example:

L1 - L2 = 388 V, L2 - L3 = 379 V, L3 - L1 = 377 V

average of the measured values = $(388 + 379 + 377) / 3 = 381$

maximum deviation from the average = $388 - 381 = 7V$

Unbalancing = $(7/381) \times 100 = 1.83\% = \text{ACCEPTABLE}$

Operating out of the indicated limits causes the loss of the guarantee as well as very serious damages.

IF THE CRANKCASE RESISTANCES ARE FITTED

when the unit is started up for the first time and following all prolonged periods of inactivity is OBLIGATORY to connect the oil resistances on the compressor crankcase at least 8 hours before the compressor is to be started.

BEFORE POWERING THE RESISTANCES, OPEN THE COMPRESSORS COCKS, IF PRESENT.

To supply the resistances is necessary to switch off the isolator switch on the unit.

To make sure that the resistances are working, check the power input with amperometric pliers.

At start-up the compressor crankcase temperature on the lower side must be higher at least of 10°C than the outside temperature.

DO NOT START THE COMPRESSOR WITH THE CRANKCASE OIL BELOW OPERATING TEMPERATURE.

REMOTE INPUT CONFIGURATIONS

Check used remote inputs are activated (ON-OFF etc.) as given in the instructions in the ELECTRIC WIRING chapter.

SETTING THE SET-POINT

Check if it is necessary to modify the set-points shown in the CONTROL chapter

EVAPORATOR WATER FLOW RATE

Check that the difference between the temperature of exchanger return and supply water corresponds to power according to this formula:

unit cooling power (kW) x 860 = Dt (°C) x flow rate (L/h).

The cooling power is shown in the TABLE ON GENERAL TECHNICAL DATA included in this manual, referred to specific air/water conditions, or in the tables on cooling PERFORMANCE IN THE TECHNICAL BULLETIN referred to various conditions of use.

Check for water side exchanger pressure drops:

- Determine the water flow rate.
- Measure the difference in pressure between exchanger input and output and compare it with the graph on WATER SIDE EXCHANGER PRESSURE DROPS.

The measurement of pressure will be easier if pressure gauges are installed as indicated in the DIAGRAM OF SUGGESTED WATER CONNECTIONS .

CONDENSER WATER FLOW RATE

Check that the difference between the temperature of exchanger return and supply water corresponds to power according to this formula:

unit cooling power + power absorbed by compressors (kW) x 860 = Dt (°C) x flow rate (L/h).

The data is shown in the table on GENERAL TECHNICAL DATA included in this manual, referred to specific air/water conditions, or in the tables on COOLING PERFORMANCE

in the TECHNICAL BULLETIN referred to various conditions of use.

Check for water side exchanger pressure drops:

- Determine the water flow rate.
- Measure the difference in pressure between exchanger input and output and compare it with the graph on WATER SIDE EXCHANGER PRESSURE DROPS.

The measurement of pressure will be easier if pressure gauges are installed as indicated in the DIAGRAM OF SUGGESTED WATER CONNECTIONS.

REFRIGERANT CIRCUIT PARAMETER CHECK

Detecting the operational conditions is useful to control the unit along time: the performed records must be kept and be available during maintenance interventions.



When the unit works in stable conditions and according to the operating limits, take note of the following data:

1. compressor discharge temperature (WARNING – BURN DANGER)
2. condensing pressure
3. liquid temperature
4. dehydrator filter upstream and downstream temperature
5. return pressure
6. return temperature
7. exchanger input water temperature
8. exchanger output water temperature

CONTROL

CONTROL INTERFACE

COOL cooling
HEAT heating

alarm ; OK 
inserted steps on total
ALARM menu access

HEAT / COOL
changement

off = unit OFF
on = unit ON

ON / OFF unit

unit status (ON – ECO –
OFF)

Enabled timing bands

INLET temperature

OUTLET temperature

Current set point

SET POINT, TIMING
BANDS, CLOCK access

Stata MENU access

Back to main menu

HELP parameter
descriptions

Back to previous shield

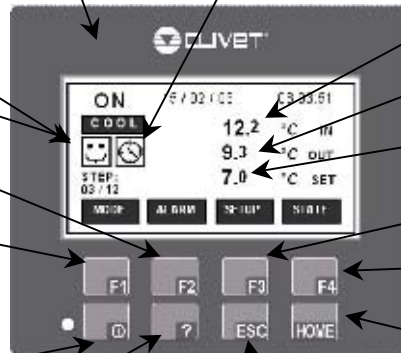

UNIT START-UP

To turn the unit on or off, hold the ON/OFF switch down for a few seconds. When the unit is on, the “ON” message is displayed; when the unit is off, the “OFF” message is displayed.

It is also possible to access the different menus when the unit is in the “OFF” mode.

It is possible to check the ON/OFF condition at a distance, using a remote device (see the ELECTRICAL CONNECTIONS chapter).

CHARACTERISTICS

THERMOREGULATION

The thermal regulation is based on the INLET temperature.

The unit is set for a specific TOTAL DIFFERENCE between the inlet and outlet water temperatures.

Usually the designed difference is 5°C, in the event that a different value is foreseen, the 17 and 18 parameters must be set again by the assistance center.

According to the total difference, the system defines the level of difference that each compressor can give : the STEP DIFFERENCE.

The regulations tend to gradually insert the compressors when the inlet temperature is over the set-point + the step difference. The compressors are activated one per time at the end of the SCANNING TIME.

This time varies according to the gap between the water inlet temperature and the Set-point value. The higher the gap value is (both negative and positive), the shorter the interval among the scanning points will be.

The value of the scanning time is displayed at the status 6; when the status 7 has reached the value of the status 6, the request of operation of the compressor is activated.

The counting of the scanning time starts together with the activation of the compressor.

The compressor to be activated is chosen to make the shut circuits operate in order to minimize the wear of the entire refrigerating circuit, as well as the single compressor.

At the end of the counting, if the inlet temperature is higher than the step difference, another compressor is inserted.
temp. H2O > set-point + step difference.

What above described is referred to the COOLING operating, in HEATING the logics is the same but overturned (compressor insertion for outlet temp. < set-point – step jump).

SET-POINT COMPENSATIONS

The compensations are evolved functions that aim at protecting the compressors and fit as much as possible, the operation of the unit to the characteristics of the system and its use.

The compensations make the time of the compressors’ operation longer and limit the number of starts-up, to make them delay the insertion time by adding an offset.

- The compensation on the DURATION is useful when the water contained in the system is limited.
- The compensation on the CHARGE is useful when a variable charge is present.

Optional components are necessary; the modifications of the parameters performed by the assistance centers have to be performed to enable and configure. In industrial applications, where a precise control of the temperature is necessary, it is possible to deactivate the COMPENSATIONS. The Status menu displays the value of the compensations on ext. temp. (status 9) and WR (status 10).

SET-POINT CORRECTIONS

The correction aim at optimising the energetic efficiency of the unit.

To do this, the corrections dynamically modify the set-point according to some variables. For example, in the summertime with very low external temperatures, therefore with a reduced load, it is possible to obtain the internal comfort even with set-points higher than the standard with a consequent higher energetic efficiency.

The *static* set-point can therefore be modified dynamically with two CORRECTIONS based on two factors external to the unit:

- Correction based on the External temp. / enthalpy
- Correction based on the Water reset (4-20 mA signal supplied by the Customer)

The *correct* set-point, to which all corrections have been added or detracted, is called PRESENT set-point and is visible at status 2.

For further details, see the ELECTRICAL CONNECTIONS chapter.

MAINTENANCE SET POINT

It can be used to maintain the installation inside the working limits, even if the unit is deactivated.

The MAINTENANCE Set Point checks the water temperature when the unit is put on OFF or Stand-by.

To do this, it periodically activates the circulation pump, tests the water temperature and even activates one or more compressors. It is necessary to modify the parameters with access reserved to the assistance centres

MENU	NUM	Parameter name	meaning
PARAMETER CONTROL MAINTENANCE	25	MantCoolEn	It enables Summer Maintenance
	114	SetMantCool	Summer maintenance set-point

DEMAND LIMIT

The function of the DEMAND LIMIT allows the limit of power so that the electric consumptions can be controlled by a signal external to the unit supplied by the customer.

On the STATUS menu, no. 22, the external signal of DEMAND LIMIT is displayed.

For further information, see the ELECTRICAL CONNECTIONS chapter.

SECOND SET-POINT

The secondary set point is activated by remote authorization (see the ELECTRICAL CONNECTIONS chapter).

It is possible to limit the minimum power which can be delivered during the time in which the secondary set point is activated by configuring the 276 MinPot2Set parameter (access reserved to the assistance centres).

TIME TABLES

The system is factory equipped with a clock function, found on the board.

By activating the timetables, it is possible to set up to 6 events for each day of the week.

If there is also a remote keyboard, the operations relative to the time and the date must be repeated on both keyboards, so that the two clocks (which are different) are synchronized.

ACCESSIBLE PARAMETERS

PARAMETER MENU STRUCTURE

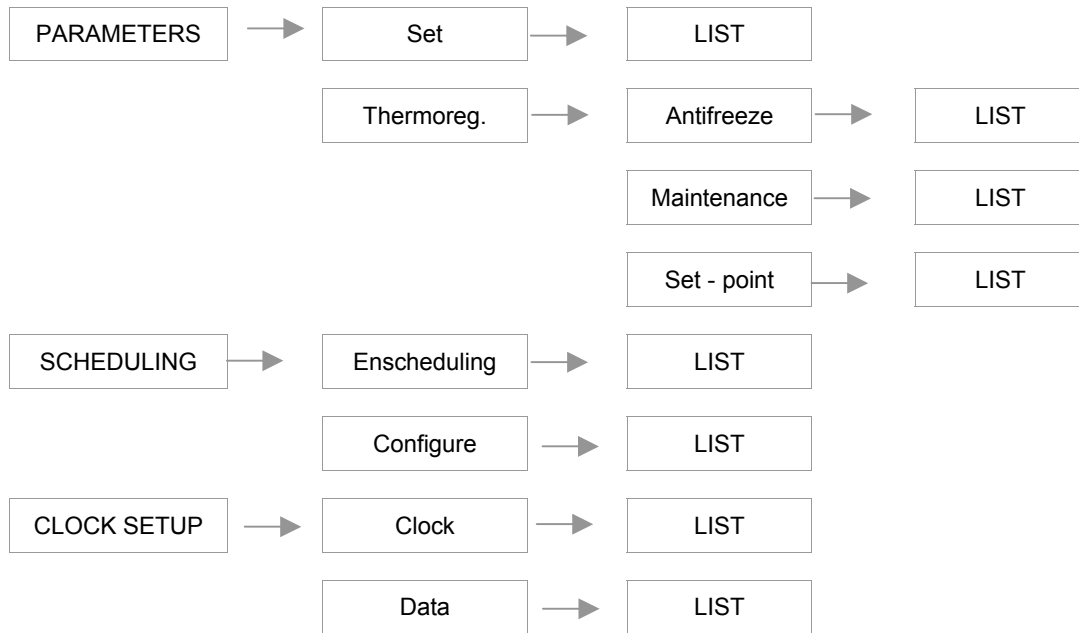

menu: PARAMETERS – THERMOREG. – SET POINT			DEFAULT values
90 / CEN	SecondSetC	Secondary cooling Set Point	12
91 / CEN	SecondSetH	NOT USED - Secondary heating Set Point	35
118 / CEN	SetCool	Cooling Set Point	6.5
119 / CEN	SetHeat	NOT USED - Heating Set Point	45
272 / CEN	SetRecovery	NOT USED	35
menu: PARAMETERS – THERMOREG. – MAINTENANCE			
114 / CEN	SetMantCool	Summer maintenance setpoint	15
117 / CEN	SetMantHeat	NOT USED - Winter maintenance setpoint	30
menu: PARAMETERS - THERMOREG.– ANTIFREEZE			
115 / CEN	AllFreeze	Antifreeze alarm set	4
121 / CEN	PreAF	Antifreeze pre-alarm set	4.5
261 / CEN	SetResist	Antifreeze heater set	4
menu: PARAMETERS – SET – UNIT - EVAPORATORS			
37 / EVAP	SetResist	Antifreeze heater set	4
39 / EVAP	ALLFreeze	Antifreeze alarm set	4
41 / EVAP	PreAF	Antifreeze pre-alarm set	4.5

KEYPAD USE

SET UP menu:

PARAMETERS

set point modification

SCHEDULING

enables/disables timing bands

CLOCK SETUP







Set the clock

ID Tast-Cen

(ATC ONLY)

PASSWORD

(ATC ONLY)

To enter in the SETUP menu		button F3 SETUP
To select the submenu		buttons ▲ ▼ F2 – F3
To access		button F1 ENTER
To scrolling voices		buttons ▲ ▼ F2 - F3
To go back a level of the menu		button ESC
To go back to the main menu		button HOME







SETUP – PARAMETERS:

THERMOREG.

Set the setpoint and the operating modes

SET

(ATC ONLY)

To enter in the SETUP menu		button F3 SETUP
To select the submenu		buttons ▲ ▼ F2 – F3
To access		button F1 ENTER
To access the desired parameter		buttons ▲ ▼ F1 – F2
To modify the parameter value		buttons + - F3 – F4
To go back to the main menu		button HOME













SETUP – SCHEDULING:

EnSCHEDULING

enables/disables timing bands

CONFIGURE

Set the timing bands

To enter in the SETUP menu		button F3 SETUP
To select the CONFIGURE submenu		buttons ▲ ▼ F2 – F3
To access		button F1 ENTER
To select DAY		buttons ▲ ▼ F1 – F2
To change week day		button F3
To select one of the 6 available daily events		button F4
To select TIME		buttons ▲ ▼ F1 – F2
To set the event hour and minutes		buttons + + F3 – F4
To select STATE		buttons ▲ ▼ F1 – F2
Select ON/OFF/ECO mode		button F4
To select Setpoint		buttons ▲ ▼ F1 – F2
Set the manual setpoint of the event		buttons + - F3 – F4
To go back to the main menu		button HOME







SETUP – CLOCK SETUP

CLOCK

Set the clock

DATA

Set the dater

To enter in the SETUP menu		button F3 SETUP
To select the CLOCK SETUP submenu		buttons ▲ ▼ F2 – F3
To access to CLOCK		button F1 ENTER
To set HOURS MINUTES SECONDS		buttons F2 F3 F4
To confirm the single setting		button F1 ENTER
To go back to the main menu		button HOME

UNIT STATUS

A sub-menu is associated with each electronic module of the unit. It displays the system status. According to the unit configuration, and then with electronic modules and options, some sub-menus and statuses can not be used.

STATA STRUCTURE

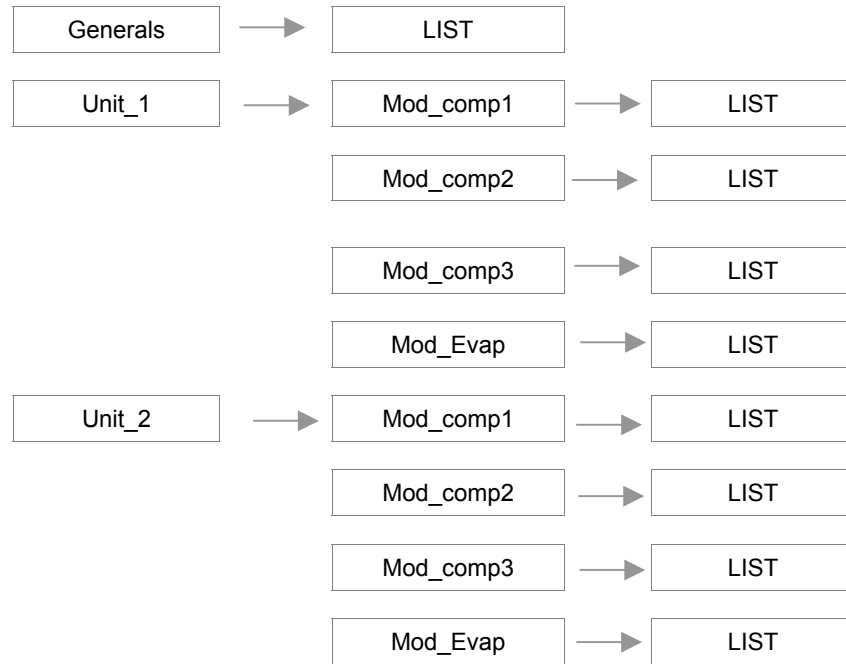

example

Visualized stata referring to
UNIT 1
COMP 2 MODULE

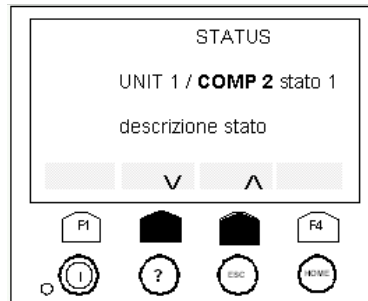

submenu:

GENERALS UNIT 1

mod_comp1
mod_comp2
mod_comp3
mod_evap

UNIT 2

mod_comp1
mod_comp2
mod_comp3
mod_evap

To enter in the STATA menu		button F4 STATE
To select the module		buttons ▲ ▼ F2 – F3
To access		button F1 ENTER
To scroll the stata		buttons ▲ ▼ F2 - F3
To go back a level of the menu		button ESC
To go back to the main menu		button HOME

Index	GENERAL stata	UM
0	Machine status	1=ON / 0=OFF
1	Machine mode	0=Cool, 1= Heat
2	Actual set point	°C (tenths)
3	Inlet temperature	°C (tenths)
4	Outlet temperature	°C (tenths)
5	Number of steps activated	
6	Current step value (compensations)	°C (tenths)
7	Step activation timer	sec
8	Step activation dynamic TimeScan	sec
9	CompExt	°C (tenths)
10	CompWR	°C (tenths)
11	CompCar	°C (tenths)
12	CompSpunti	°C (tenths)
13	CompDuty	°C (tenths)
14	Ambient temperature	°C (tenths)
15	Ambient humidity	%
16	Free Cooling valve percentage	%
17	Free Cooling flow percentage	%
18	Free Cooling valve control	1=ON / 0=OFF
19	Pump 1 status	1=ON / 0=OFF
20	Pump 2 status	1=ON / 0=OFF
21	Water Reset	%
22	Demand Limit	%
60	Digital input	bit map of a byte
68	Water flow analogic out	
69	Pump module digital out	bit map of a byte
71	BitMap connected nodes MS	bit map of a byte
72	Hours pump 1 PMP	
73	Hours pump 2 PMP	
74	Hours pump 3 PMP	

Index	UNIT_1 – MOD COMP_1 Stata	UM
29	Compressor 1	1=ON / 0=OFF
30	Compressor 2	1=ON / 0=OFF
31	Compressor 3	1=ON / 0=OFF
32	Cp 1 timer status	1=ON / 0=OFF
33	Cp 2 timer status	1=ON / 0=OFF
34	Cp 3 timer status	1=ON / 0=OFF
35	Valve 1 c1 status	1=ON / 0=OFF
36	Valve 2 c1 status	1=ON / 0=OFF
37	Valve 3 c1 status	1=ON / 0=OFF
38	Valve 1 c2 status	1=ON / 0=OFF
39	Valve 2 c2 status	1=ON / 0=OFF
40	Valve 3 c2 status	1=ON / 0=OFF
41	Valve 1 c3 status	1=ON / 0=OFF

Index	UNIT_1 – MOD COMP_1 Stata	UM
42	Valve 2 c3 status	1=ON / 0=OFF
43	Valve 3 c3 status	1=ON / 0=OFF
44	Liquid solenoid	1=ON / 0=OFF
45	Coil temperature	°C (tenths)
46	Recovery temperature	°C (tenths)
47	Condensation pressure	bar
48	Evaporation pressure	bar
49	Fan Status	bar
50	Defrost Status	1=ON / 0=OFF
51	Defrost count time	sec
52	Compressor 1 operating time	
53	Comp. 1 starts	
54	Compressor 2 operating time	
55	Comp. 2 starts	

Index	UNIT_1 – MOD COMP_1 Stata	UM
56	Compressor 3 operating time	
57	Comp. 3 starts	
58	Recovery valve	1=ON / 0=OFF
59	Recovery PREHP delay	sec
61	Digital input	bit map of a byte
75	Daikin calculated power	%
76	PEvapOp	bar
77	Taspirazione	°C(tenths)
78	Tscarico	°C(tenths)
79	Valve opening	%
80	SuperHeat	°C(tenths)
81	SuperHeatSPOperativo	°C(tenths)
82	TempSaturaCondensazione	°C(tenths)

Index	UNIT_1 – MODEVAP_1 Stata	UM
23	Tout1	°C (tenths)
24	Tout2	°C (tenths)
25	Tinput	°C (tenths)
26	Pump 1 status	1=ON / 0=OFF
27	Pump 2 status	1=ON / 0=OFF
28	Heater status	1=ON / 0=OFF
62	Digital input	bit map of a byte

ALARMS

BEFORE RESETTING THE ALARM, IDENTIFY AND ELIMINATE THE CAUSE OF ITS ACTIVATION.
REPEATED RESETS CAN CAUSE IRREVERSIBLE DAMAGES.



The presence of an alarm is signaled by the icon flashing.

The cumulative block relay activates simultaneously, according to the type of alarm.

Alarms can be reset once the conditions that caused them to trip have been removed.

ALARMS and faults show a potentially dangerous situation for the machine integrity. An immediate analysis is necessary to detect the causes of the block. A repeated reset can provoke irreversible damage. That is why reset is MANUAL.

PRE-ALARMS AND SIGNALIZATIONS show a situation similar to that one described above. The occurrence of an alarm is acceptable if it is occasional and/or in transitory situations (for example, when the plant starts). In uncertain cases, please contact the authorized assistance center.

VIEW ALARM







To visualize the alarm in progress

STORE ALARM

To visualize the historical alarm

DEL STORE

To delete the historical alarm

To enter in the ALARM menu		button F2 ALARM
To select VIEW ALARM		buttons ▲ ▼ F2 – F3
To access		button F1 ENTER
To scroll the active alarms		buttons ▲ ▼ F2 - F3
To reset the alarm in progress		button F1 ENTER
To go back a level of the menu		button ESC
To go back to the main menu		button HOME

An alarm list is associated with the inputs of each electronic module of the unit.

According to the unit configuration, and then with electronic modules and options, some lists and/or ALARMS can not be used.

ALARM STRUCTURE

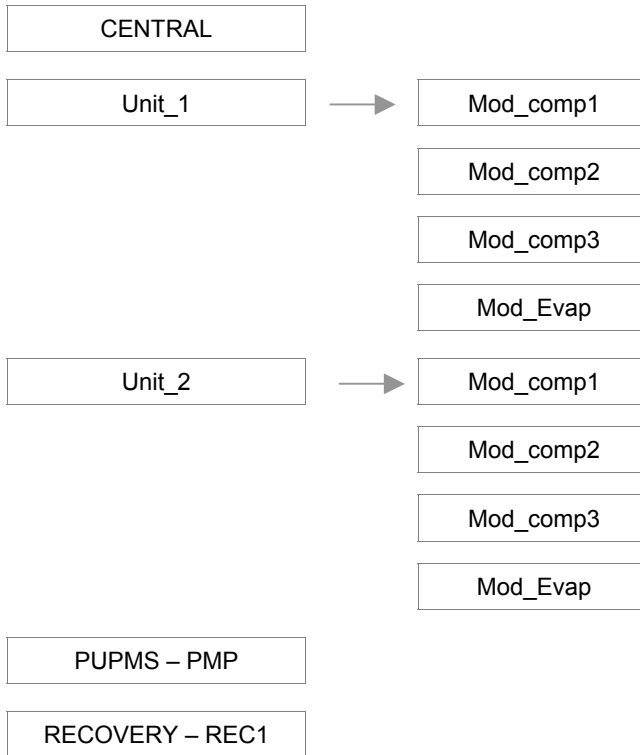

example

CEN : central module alarm
 14 : alarm identificative string
 E014 : alarm description

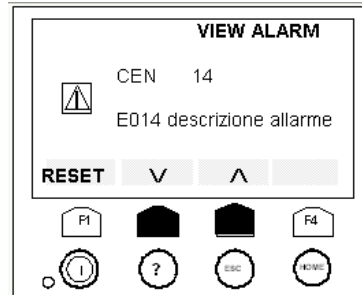

CENTRAL MODULE		
Str	Name	
0	E001	H2O IN temp. probe fault on control module
1	E002	H2O OUT temp. probe fault on control module
2	E003	Outside air temp. probe fault
3	E004	Water Reset input fault
4	E005	Outside RH% probe fault
5	E006	Thermal cut-out alarm pump 1 on control module
6	E007	Thermal cut-out alarm pump 2 on control module
7	E008	Flow switch alarm on control module
8	E009	System pressure alarm
9	E010	Phase monitor alarm
10	E011	Antifreeze alarm on control module
11	E012	Antifreeze pre-alarm on control module
12	E013	Change CENTRAL pump
13	E014	Unit configuration alarm
14	E015	Demand Limit input fault
15	E016	Can net disconnectedness on control module
59	E017	Inhibits control in heating
60	E018	Incongruent deltaT alarm
62	E019	Ext low temperature alarm

COMPRESSOR MODULE		
Str	Name	
16	E101	Cond./ Evap. temp. probe fault
17	E102	Condensing pressure probe fault
18	E103	Evaporation pressure probe fault
19	E104	Recovery temp. probe fault
20	E105	High pressure alarm
21	E106	Low pressure alarm
22	E107	Fan/Pump thermal cut-out alarm
23	E111	Cond. / Evap. H2O flow alarm
24	E112	High pressure pre-alarm 1
25	E113	High pressure pre-alarm 2
26	E114	Low pressure pre-alarm
27	E115	Force defrost alarm
28	E116	Max Press. diff. alarm
29	E117	Recovery H2O flow alarm
30	E118	Heat recovery HP pre-alarm
31	E108	Compressor 1 thermal cut-out alarm
32	E109	Compressor 2 thermal cut-out alarm
33	E110	Compressor 3 thermal cut-out alarm
47	E213	Module not connected
49	E119	Oil differential pressure alarm
58	E120	Condenser frost alarm
61	E121	BP2 prealarm
63	E123	TA TEE alarm
64	E124	TS TEE alarm
65	E125	max TS TEE prealarm
66	E126	max TS TEE prealarm
67	E127	power fail alarm
68	E128	stepper motor error alarm

PUMP MODULE		
Str	Name	
53	E501	Water flow probe fault
54	E502	Thermal pump 1alarm Pump Module
55	E503	Thermal pump 2alarm Pump Module
56	E504	Thermal pump 3alarm Pump Module
57	E505	Max flow-rate signal Pump Module

RECOVERY EXPANSION MODULE		
Str	Name	
50	E301	Out recovery probe alarm
51	E302	Gas temperature probe alarm

EVAPORATOR MODULE		
Str	Name	
34	E201	Evaporator inlet probe fault
35	E202	Evaporator outlet probe 1 fault
36	E202	Evaporator outlet probe 2 probe fault
37	E203	Programmable evaporator input alarm
38	E204	Thermal cut-out alarm, evaporator pump 1
39	E205	Thermal cut-out alarm, evaporator pump 2
40	E206	Evaporator flow switch alarm
41	E207	Evaporator system fill alarm
42	E208	Change pumps on evaporator
43	E209	Antifreeze alarm on evaporator
44	E210	Tout 1, antifreeze pre-alarm on evaporator
45	E211	Tout 2, antifreeze pre-alarm on evaporator
46	E212	System pump lockout
48	E214	Module not connected

ROUTINE MAINTENANCE

BEFORE UNDERTAKING ANY SORT OF MAINTENANCE OR CLEANING, DISCONNECT THE ELECTRICAL POWER SUPPLY TO THE UNIT, AND ENSURE THAT OTHER PEOPLE CANNOT RE-CONNECT IT .

All equipment is subjected to wear out.

The maintenance makes :

1. keeps the unit efficiency
2. the components last longer
3. keeps their efficiency and limits breakdowns

Therefore, it is fundamental to perform periodical checks: a few controls can be performed by the user (AUTONOMOUS MAINTENANCE) and they are mainly

cleaning activities; otherwise, controls have to be performed by specialized technicians (INSPECTIONS).

The machine should have a log book used to keep track of the performed controls. This will make fixing up breakdowns easier.

Take note of the date, type of control (autonomous maintenance, inspection or fixing up), description of the control, actions taken and so on.

SERVICES

Parts subject to intervention:

- **WATER EXCHANGER**

- **STRUCTURE**

WATER EXCHANGER

It is very important for the exchanger to be able to provide the maximum thermal exchange. Therefore, it is essential for the inner surfaces to be clean of dirt and incrustations.

Periodically check the difference between the temperature of the supply water and the condensation temperature. If the difference is greater than 8°C–10°C it is advisable to clean the exchanger.

STRUCTURE

Check the condition of the parts making up the structure. Paint so as to eliminate or reduce oxidation at the points in the unit where this problem may occur. Check that the

panelling is fastened correctly. Poor fastening may give rise to malfunctions and abnormal noise and vibration.

MAINTENANCE INSPECTIONS

Foresee inspection assistance carried out by authorized centers or by qualified personnel.

The inspections should be carried out at least:

- - Every year for only the cooling units
- - Every six months for the cooling and warming units

The frequency, however, depends on the use: in the event of frequent use (continuous or very intermittent use, near the operating limits, etc) or critical use (service necessary) it is recommended to plan inspections at close intervals.

The inspections to be performed are as follows:

- verify the power supply tension (when emptied or filled)
- inspect the electrical board (status of solenoid starter contacts, terminal closings, the status of wiring and relevant insulations)
- inspect the absorption of the single electrical loads
- verify the cleaning and the efficiency of the exchangers
- inspect the cleaning of the filters (air/water)

- verify the leakage from the refrigerating circuit
- Verify the protection devices (safety valves, pressure switches, thermostats, etc.), the adjustment systems, the control devices (alarm signalizations, probes, manometers, etc)
- check the operating parameters of the refrigerating circuit (see the following REFRIGERANT TABLES and the START-UP section)

For units equipped with safety valves, follow the Manufacturer's instructions.

Verify periodically the cleaning of the safety valves and that oxidative / corrosive phenomena are not present, in particular for installations near the sea, in industrial areas or in rooms with a corrosive atmosphere.

97/23 CE PED DIRECTIVE

97/23 CE PED DIRECTIVE gives instructions for installers, users and maintenance technicians as well. Refer to local actuation norms.

In Italy, refer to the Ministerial Decree of 1st December 2004 no. 329 (and following modifications) which defines the performances to be executed; the units of 1st category and those defined by the art. 3.3 97/23/EC are not included in this regulation (see the serial number plate on the unit) .

Briefly and as an example, see the following :

1. COMPULSORY VERIFICATION OF THE FIRST INSTALLATION only for units assembled on the installer's building site (for ex. Condensing circuit + direct expansion unit)
2. CERTIFICATION OF SETTING IN SERVICE for all the units
3. PERIODICAL VERIFICATIONS to be executed with the frequency indicated by the Manufacturer (see the MAINTENANCE INSPECTIONS paragraph)

PUT AT REST

If a long period of inactivity is foreseen, for example the winter for the cooling unit, the following is recommended:

- to turn the power off in order to avoid electrical risks or damages by lightning strike
- to avoid the risk of frosts as shown in the HYDRAULIC CONNECTIONS section, and, in particular
 - to empty or add glycole in the plant sections subjected to temperatures below zero
 - to empty or add glycole in the water heating coils, also in summer
 - to power antifreeze resistances if present

If the period of inactivity is particularly long or in the event of extremely low temperatures, the external fans can be blocked temporarily; therefore, it is recommended to switch them on every month in order to avoid seizures or electrical overloads when the unit will be switched on.

The restarting of the unit has to be carried out by qualified personnel, in particular, after the winter break for cooling units or when seasonal switching should be performed.

When restarting, refer to the SWITCHING ON section.

Schedule technical assistance in advance to avoid hitches and be able to use the installation when necessary.

REFRIGERANT TABLES

THIS SECTION IS DEVOTED ONLY TO QUALIFIED TECHNICIANS THAT KNOW THE FOLLOWING:

- THE OPERATIONAL PRINCIPLES OF THE REFRIGERATING CIRCUIT OPERATION
- THE MODES OF DETECTING TEMPERATURE AND PRESSURE
- THE RISKS RELEVANT TO THESE OPERATIONS

The data of the tables allow the testing of the refrigerating circuit operation by the detection of a few objective parameters.

The data are significant if they are detected simultaneously and while the refrigerating circuit is running.

- Liquid temperature
- Return pressure
- Return temperature
- Condensing pressure

OVERHEATING = return temperature – Saturation temperature			
	R22	R407C	R410A
Return pressure	3.8 bar	3.8 bar	7.2 bar
Return temperature	7.3 °C	7.3 °C	7.3 °C
overheating	$7.3 - (-1.13) = 8.43$ °C	$1.3 - 1.18 = 6.12$ °C for calculation consider the Td (dew point)	$7.3 - 0.8 = 6.5$ °C
SUBCOOLING = condensing temperature (pressure *) – liquid temperature			
	R22	R407C	R410A
Condensing pressure	18.6 bar	18.6 bar	29.6 bar
Liquid temp.	42.9 °C	42.9 °C	45 °C
subcooling	$50.39 - 42.9 = 7.49$ °C	$44.74 - 42.9 = 1.84$ °C for calculation consider the Tb (bubble point)	$49.91 - 45 = 4.91$ °C

* It is important that the condensation pressure is detected as close as possible to the point where the liquid temperature is detected, in the event that the calculation will be effected by the losses of charge (and, therefore, of temperature) caused by the refrigerating circuit components placed between the two measurement points.

For R410A the glide was not considered, since it is close to 0.

The values in the tables refer to a specific refrigerant supplier; slight differences are possible with other suppliers.

Pg = P gauge = relevant pressure (read on the pressure gauge)

Ts : saturation pressure

Td = dew point temperature

Tb = bubble point temperature

Pg	R134a Ts [°C]	Pg	R134a Ts [°C]	Pg	R134a Ts [°C]	Pg	R134a Ts [°C]
0.0	-26.36	11.0	46.32	22.0	73.74	33.0	92.30
0.2	-22.31	11.2	46.96	22.2	74.14	33.2	92.59
0.4	-18.76	11.4	47.59	22.4	74.53	33.4	92.88
0.6	-15.59	11.6	48.22	22.6	74.92	33.6	93.16
0.8	-12.71	11.8	48.84	22.8	75.31	33.8	93.45
1.0	-10.08	12.0	49.46	23.0	75.69	34.0	93.73
1.2	-7.64	12.2	50.06	23.2	76.07	34.2	94.01
1.4	-5.37	12.4	50.66	23.4	76.45	34.4	94.29
1.6	-3.24	12.6	51.26	23.6	76.83	34.6	94.57
1.8	-1.23	12.8	51.84	23.8	77.21	34.8	94.85
2.0	0.67	13.0	52.42	24.0	77.58	35.0	95.12
2.2	2.48	13.2	53.00	24.2	77.95	35.2	95.40
2.4	4.20	13.4	53.56	24.4	78.32	35.4	95.67
2.6	5.84	13.6	54.13	24.6	78.68	35.6	95.94
2.8	7.42	13.8	54.68	24.8	79.04	35.8	96.21
3.0	8.93	14.0	55.23	25.0	79.41	36.0	96.48
3.2	10.39	14.2	55.78	25.2	79.76	36.2	96.75
3.4	11.79	14.4	56.32	25.4	80.12	36.4	97.01
3.6	13.15	14.6	56.85	25.6	80.48	36.6	97.28
3.8	14.46	14.8	57.38	25.8	80.83	36.8	97.54
4.0	15.74	15.0	57.91	26.0	81.18	37.0	97.80
4.2	16.97	15.2	58.43	26.2	81.53	37.2	98.06
4.4	18.17	15.4	58.94	26.4	81.87	37.4	98.32
4.6	19.33	15.6	59.45	26.6	82.22	37.6	98.58
4.8	20.47	15.8	59.96	26.8	82.56	37.8	98.84
5.0	21.57	16.0	60.46	27.0	82.90	38.0	99.09
5.2	22.65	16.2	60.95	27.2	83.24	38.2	99.34
5.4	23.70	16.4	61.44	27.4	83.58	38.4	99.60
5.6	24.73	16.6	61.93	27.6	83.91	38.6	99.85
5.8	25.73	16.8	62.42	27.8	84.24	38.8	100.09
6.0	26.71	17.0	62.90	28.0	84.58	39.0	100.34
6.2	27.67	17.2	63.37	28.2	84.90	39.2	100.59
6.4	28.62	17.4	63.84	28.4	85.23	39.4	100.83
6.6	29.54	17.6	64.31	28.6	85.56	39.6	-
6.8	30.44	17.8	64.77	28.8	85.88	39.8	-
7.0	31.33	18.0	65.23	29.0	86.20	40.0	-
7.2	32.20	18.2	65.69	29.2	86.52	40.2	-
7.4	33.05	18.4	66.14	29.4	86.84	40.4	-
7.6	33.89	18.6	66.59	29.6	87.16	40.6	-
7.8	34.72	18.8	67.04	29.8	87.47	40.8	-
8.0	35.53	19.0	67.48	30.0	87.79	41.0	-
8.2	36.32	19.2	67.92	30.2	88.10	41.2	-
8.4	37.11	19.4	68.36	30.4	88.41	41.4	-
8.6	37.88	19.6	68.79	30.6	88.72	41.6	-
8.8	38.64	19.8	69.22	30.8	89.03	41.8	-
9.0	39.39	20.0	69.64	31.0	89.33	42.0	-
9.2	40.13	20.2	70.07	31.2	89.64	42.2	-
9.4	40.85	20.4	70.49	31.4	89.94	42.4	-
9.6	41.57	20.6	70.90	31.6	90.24	42.6	-
9.8	42.27	20.8	71.32	31.8	90.54	42.8	-
10.0	42.97	21.0	71.73	32.0	90.83	43.0	-
10.2	43.66	21.2	72.14	32.2	91.13	43.2	-
10.4	44.33	21.4	72.54	32.4	91.43	43.4	-
10.6	45.00	21.6	72.95	32.6	91.72	43.6	-
10.8	45.66	21.8	73.35	32.8	92.01	43.8	-

TROUBLESHOOTING

THE OPERATIONS MUST BE CARRIED OUT BY TECHNICAL QUALIFIED PERSONNEL HAVING THE REQUISITES UNDER LAW REQUISITES AND IN CONFORMITY WITH THE SAFETY REGULATIONS IN FORCE.

THE INTERVENTIONS WITHIN THE WARRANTY PERIOD WILL BE CARRIED OUT BY AUTHORIZED SERVICE CENTERS.

**BEFORE RESETTING AN ALARM, IDENTIFY AND ELIMINATE ITS CAUSE.
REPEATED RESETS MAY CAUSE SERIOUS DAMAGES.**

In certain machine configurations, some safeties may be placed in series and lead back to a single input on the electronic module.

Therefore, check on the electrical diagram whether the device to which the alarm corresponds has other devices or safeties connected in series.

Below is a list of the possible causes of alarms.

HIGH PRESSURE (in cooling)

1. high water temperature (see operating limits)
2. insufficient water flow to the exchanger (high thermal difference between input and output)
3. not CONSTANT flow (for example, if the pumps are turned off, certain areas of the plant are excluded or included, other uses are isolated, etc)
4. Dirt water filter / valves open /air bubbles in the plant
5. dirty exchanger
6. Manostat/transducer: loose electric contacts/terminals, wiring cables interrupted
7. condensation gas in the cooling circuit
8. Too much refrigerant
9. Check the trigger point for the manostat and transducer
10. Check the manostat or transducer pressure control point (deposits of oil, dirt, pin blocked mechanically)

LOW PRESSURE (in cooling)

1. low water temperature (see operating limits)
2. insufficient water flow to the exchanger (high thermal difference between input and output)
3. not CONSTANT flow (for example, if the pumps are turned off, certain areas of the plant are excluded or included, other uses are isolated, etc)
4. Water filter clean / valves open /air bubbles in the plant
5. dirty exchanger
6. Manostat/transducer: loose electric contacts/terminals, wiring cables interrupted
7. refrigerant circuit empty, visible leaks of refrigerant/oil, insufficient charge
8. Blocked dehydrator filter
9. thermostatic device not operating correctly
10. Check the trigger point for the manostat and transducer
11. Check the manostat or transducer pressure control point (deposits of oil, dirt, pin blocked mechanically)

FAULTY PROBE

1. Identify the part on the wiring diagram.
2. Loose electric contacts/terminals, leads broken
3. Check the correct probe ohmic level (using a tester)
4. Change the probe.
5. Check the electronic module configuration (only an authorised service centre can do this)
6. Change the electronic module

FAULTY PRESSURE TRANSDUCER

1. Identify the part on the wiring diagram
2. Loose electric contacts/terminals, leads broken
3. Check the pressure test points are in working order
4. Change the part
5. Check the electronic module configuration (only an authorised service centre can do this)
6. Change the electronic module

COMPRESSOR PROTECTION

1. Identify the part on the wiring diagram
2. Loose electric contacts/terminals, leads broken
3. electrical windings interrupted
4. Vacuum power voltage below the limits
5. power contactors / contacts defective
6. start-up power voltage lower than the limits
7. electrical absorption high / unbalanced
8. High compressor discharge temperature > thermostatic device needs calibrating, insufficient refrigerant charge

DECOMMISSIONING OF THE UNIT

DISCONNECTING THE UNIT

The units must be disconnected by authorised personnel, who before proceeding must first read the Residual Risks section in this manual.

Before disconnecting the unit, the following must be recovered, if present:

- the refrigerant (if the circuits cannot be isolated): the refrigerant must be removed using suction devices operating in a closed circuit, so as to ensure that none of the compound is released into the atmosphere.
- the antifreeze in the circuits: when removing this fluid, make sure that it does not leak and that it is not released into the environment. The antifreeze fluid must be stored in special containers.

When recovering the substances present in the unit, all measures must be taken to avoid damaging persons and things and polluting the surrounding area.

Awaiting dismantling and disposal, the unit can also be stored outdoors, as bad weather and rapid changes in temperature will not cause damage to the environment, if electric, cooling and hydraulic circuits of the unit are integral and closed.

DISMANTLING AND DISPOSAL

THE UNIT MUST ALWAYS BE SENT TO AUTHORISED CENTRES FOR DISMANTLING AND DISPOSAL.

When dismantling the unit, the fan, the motor and the coil, if operating, may be recovered by the specialist centres for reuse.

All the materials must be recovered or disposed of in compliance with the corresponding national standards in force.

For further information on the decommissioning of the unit, contact the manufacturer.

TECHNICAL DATA

Acoustic configuration: Standard (ST)/Extremely low noise(EN) / Energy efficiency: Efficiency class A

Size		2.160	2.180	2.220	2.250	2.280	2.300	2.320	2.340	2.360	2.420	2.450	2.480	2.540	2.600
COOLING															
Cooling capacity	1 kW	468	536	610	697	758	831	900	960	1011	1169	1209	1248	1448	1537
Compressor power input	kW	91.6	105	118	136	149	163	176	187	198	229	237	246	285	302
Total power input	kW	92.6	106	119	137	150	164	177	188	199	230	238	247	286	303
Heating capacity total recovery	2 kW	548	627	727	814	892	976	1056	1131	1197	1375	1424	1472	1720	1812
Heating capacity partial recovery	2 kW	83.9	96.1	109	125	136	149	161	172	181	210	217	224	260	276
EER		5.05	5.05	5.14	5.07	5.05	5.08	5.07	5.09	5.07	5.08	5.07	5.06	5.06	5.08
ESEER		5.75	5.75	5.85	5.77	5.75	5.78	5.78	5.8	5.77	5.78	5.77	5.76	5.76	5.78
HEATING															
Heat output	3 kW	548	627	727	814	892	976	1056	1131	1197	1375	1424	1472	1720	1812
Compressor power input	kW	110	125	149	167	184	202	220	235	250	284	294	304	345	379
Total power input	kW	111	126	150	168	185	203	221	236	251	285	295	305	346	380
COP		4.92	4.97	4.86	4.85	4.82	4.81	4.78	4.79	4.77	4.83	4.83	4.83	4.97	4.77
COMPRESSOR															
Type of compressors	4	SCREW													
No. of Compressors	Nr	2													
Rated power (C1)	HP	80	90	110	125	140	140	160	160	180	210	210	240	270	300
Nominal Power (C2)	HP	80	90	110	125	140	160	160	180	180	210	240	240	270	300
Std Capacity control steps	Nr	STEPLESS													
Oil charge (C1)	l	11	11	22	19	19	19	35	35	35	35	35	25	25	25
Oil charge (C2)	l	11	11	22	19	19	35	35	35	35	35	35	25	25	25
Refrigerant circuits	Nr	2													
INTERNAL EXCHANGER															
Type of internal exchanger	5	S&T													
No. of internal exchangers	Nr	1													
Water flow	l/s	22.3	25.6	29.1	33.3	36.2	39.7	43	45.9	48.3	55.9	57.7	59.6	69.2	73.4
internal exchanger pressure drop	kPa	40.9	41	43.9	65	49.6	34.4	39.7	79.6	87.3	51	54.1	57.4	105.3	117
Water content	l	277.7	233.3	248.3	233.3	418.6	409.6	409.6	409.6	409.6	451.4	451.4	451.4	493	493
EXTERNAL EXCHANGER															
type of external exchanger	6	S&T													
Water flow rate	l/s	26.7	30.6	34.8	39.8	43.3	47.5	51.4	54.8	57.8	66.8	69.1	71.4	82.8	87.8
external exchanger pressure drop	kPa	16.5	15.5	27.2	21.7	22.1	23.3	24.2	25.7	26.9	18.9	18.7	18.5	17.8	17.7
Water content	l	59	69	59	75	80	85	90	93	95	136	142	147	169	183
Quantity	Nr	2													
CONNECTIONS															
Water fittings	7	6"	6"	6"	6"	8"	8"	8"	8"	8"	8"	8"	8"	8"	8"
Water fittings	7	5"	5"	5"	5"	5"	5"	5"	5"	5"	6"	6"	6"	6"	6"
POWER SUPPLY															
Standard power supply	V	400/3/50													

- (1) data referred to the following conditions :
 internal exchanger water = 12/7°C
 external exchanger water = 30/35°C
 (2) recovery exchanger water=40/45°C
 (3) data referred to the following conditions :
 external exchanger water = 40/45°C
 internal exchanger water = 12/7°C

- (4) DSW = twin-screw compressor
 (5) S&T = tube bundle
 (6) S&T = tube bundle
 (7) Fittings with flexible joint and solder pipe connection

OPERATING LIMITS (COOLING)

SIZE		2.160	2.180	2.220	2.250	2.280	2.300	2.320	2.340	2.360	2.420	2.450	2.480	2.540	2.600
EXTERNAL EXCHANGER															
Max water inlet temperature	1 °C	50	50	50	50	50	50	50	50	50	50	50	50	50	50
Max water inlet temperature	2 °C	55	55	55	55	55	55	55	55	55	55	55	55	55	55
Max water inlet temperature	3 °C	62	62	62	62	62	62	62	62	62	62	62	62	62	62
Min. water outlet temperature	1 °C	27	27	27	27	27	27	27	27	27	27	27	27	27	27
INTERNAL EXCHANGER															
Max water inlet temperature	°C	20,5	20,5	20,5	20,5	20,5	20,5	20,5	20,5	20,5	20,5	20,5	20,5	20,5	20,5
Min. water outlet temperature	4 °C	5	5	5	5	5	5	5	5	5	5	5	5	5	5
Min. water outlet temperature	5 °C	-8	-8	-8	-8	-8	-8	-8	-8	-8	-8	-8	-8	-8	-8

- (1) unit at full load: internal exchanger water 12/7°C
 (2) capacity-controlled unit (automatic capacity control)
 (3) unit not operating

- (4) Standard Version
 (5) Low temperature version
 Fluid with ethylene glycol of 40%

Acoustic configuration: Standard (ST)/Extremely low noise(EN) / Energy efficiency: Efficiency class B

Size		2.160	2.180	2.220	2.250	2.280	2.300	2.320	2.340	2.360	2.420	2.450	2.480	2.540	2.600
COOLING															
Cooling capacity	1 kW	408	455	562	620	698	773	828	903	952	993	1049	1171	1295	1458
Compressor power input	kW	86	96.5	118	130	147	162	177	187	196	208	223	246	271	308
Total power input	kW	87	97.5	119	131	148	163	178	188	197	209	224	247	272	309
Heating capacity total recovery	2 kW	473	528	649	718	809	894	962	1039	1095	1148	1217	1358	1503	1692
Heating capacity partial recovery	2 kW	74.2	82.7	102	112	127	140	151	163	172	180	191	212	235	265
EER		4.69	4.67	4.73	4.72	4.71	4.73	4.66	4.8	4.82	4.74	4.68	4.74	4.75	4.72
ESEER		5.28	5.26	5.33	5.32	5.3	5.33	5.25	5.41	5.43	5.34	5.27	5.34	5.35	5.32
HEATING															
Heat output	3 kW	473	528	649	718	809	894	962	1039	1095	1148	1217	1358	1503	1692
Compressor power input	kW	107	119	146	161	184	201	218	231	243	258	275	303	337	381
Total power input	kW	108	120	147	162	185	202	219	232	244	259	276	304	338	382
COP		4.4	4.4	4.42	4.44	4.37	4.42	4.39	4.48	4.48	4.43	4.41	4.47	4.44	4.43
COMPRESSOR															
Type of compressors	4	SCREW													
No. of Compressors	Nr	2													
Rated power (C1)	HP	80	90	110	125	140	140	160	160	180	210	210	240	270	300
Nominal Power (C2)	HP	80	90	110	125	140	160	160	180	180	210	240	240	270	300
Std Capacity control steps	Nr	STEPLESS													
Oil charge (C1)	l	11	11	22	19	19	19	35	35	35	35	35	25	25	25
Oil charge (C2)	l	11	11	22	19	19	35	35	35	35	35	35	25	25	25
Refrigerant circuits	Nr	2													
INTERNAL EXCHANGER															
Type of internal exchanger	5	S&T													
No. of internal exchangers	Nr	1													
Water flow rate	l/s	19.5	21.7	26.8	29.6	33.3	36.9	39.6	43.1	45.5	47.4	50.1	55.9	61.9	69.7
internal exchanger pressure drop	kPa	61	56.2	51.4	61.1	75.2	66.9	58.9	39.9	43.8	78.6	52.2	66.3	79.3	70.9
Water content	l	164.4	159.3	263.3	263.3	263.3	248.3	241.2	409.6	409.6	418.6	409.6	400.9	400.9	461.8
EXTERNAL EXCHANGER															
type of external exchanger	6	S&T													
Water flow rate	l/s	23.6	26.4	32.5	35.8	40.4	44.7	48	52.1	54.9	57.4	60.8	67.7	74.8	84.4
external exchanger pressure drop	kPa	31.7	29.7	34.5	33.4	34.8	33.4	30.5	33	34	36.9	36.3	35.9	34.9	30.9
Water content	l	38	43	49	54	59	67	75	75	75	80	85	95	101	131
Quantity	Nr	2													
CONNECTIONS															
Water fittings	7	5"	5"	6"	6"	6"	6"	6"	8"	8"	8"	8"	8"	8"	8"
Water fittings	7	5"	5"	5"	5"	5"	5"	5"	5"	5"	5"	5"	5"	5"	6"
POWER SUPPLY															
Standard power supply	V	400/3/50													

(1) data referred to the following conditions :

internal exchanger water = 12/7°C

external exchanger water = 30/35°C

(2) recovery exchanger water=40/45°C

(3) data referred to the following conditions :

external exchanger water = 40/45°C

internal exchanger water = 12/7°C

(4) DSW = twin-screw compressor

(5) S&T = tube bundle

(6) S&T = tube bundle

(7) Fittings with flexible joint and solder pipe connection

OPERATING LIMITS (COOLING)

Size		2.160	2.180	2.220	2.250	2.280	2.300	2.320	2.340	2.360	2.420	2.450	2.480	2.540	2.600
EXTERNAL EXCHANGER															
Max water inlet temperature	1 °C	51	51	51	51	51	51	51	51	51	51	51	51	51	51
Max water inlet temperature	2 °C	55	55	55	55	55	55	55	55	55	55	55	55	55	55
Max water inlet temperature	3 °C	62	62	62	62	62	62	62	62	62	62	62	62	62	62
Min. water outlet temperature	1 °C	26	26	26	26	26	26	26	26	26	26	26	26	26	26
INTERNAL EXCHANGER															
Max water inlet temperature	°C	20.5	20.5	20.5	20.5	20.5	20.5	20.5	20.5	20.5	20.5	20.5	20.5	20.5	20.5
Min. water outlet temperature	4 °C	5	5	5	5	5	5	5	5	5	5	5	5	5	5
Min. water outlet temperature	5 °C	-8	-8	-8	-8	-8	-8	-8	-8	-8	-8	-8	-8	-8	-8

(1) unit at full load: internal exchanger water 12/7°C

(2) capacity-controlled unit (automatic capacity control)

(3) unit not operating

(4) Standard Version

(5) Low temperature version

Fluid with ethylene glycol of 40%

CORRECTION FACTOR FOR ANTIFREEZE SOLUTIONS

Internal exchanger (evaporator)

% ethylene glycol by weight		5%	10%	15%	20%	25%	30%	35%	40%
Freezing temperature	°C	-2.0	-3.9	-6.5	-8.9	-11.8	-15.6	-19.0	-23.4
Safety temperature	°C	3.0	1.0	-1.0	-4.0	-6.0	-10.0	-14.0	-19.0
Cooling Capacity Factor	Nr	0.995	0.990	0.985	0.981	0.977	0.974	0.971	0.968
Compressor input Factor	Nr	0.997	0.993	0.990	0.988	0.986	0.984	0.982	0.981
Internal exchanger Glycol solution flow Factor	Nr	1.003	1.010	1.020	1.033	1.050	1.072	1.095	1.124
Pressure drop Factor	Nr	1.029	1.060	1.090	1.118	1.149	1.182	1.211	1.243

The correction factors shown refer to water and glycol ethylene mixes used to prevent the formation of frost on the exchangers in the water circuit during inactivity in winter.

External exchanger (condenser)

% ethylene glycol by weight		5%	10%	15%	20%	25%	30%	35%	40%
Freezing temperature	°C	-2.0	-3.9	-6.5	-8.9	-11.8	-15.6	-19.0	-23.4
Safety temperature *	°C	-0.3	-0.6	-0.9	-1.3	-1.8	-2.2	-2.7	-3.3
Cooling Capacity Factor	Nr	1.00	0.99	0.99	0.98	0.97	0.97	0.96	0.95
Compressor input Factor	Nr	1.01	1.01	1.02	1.02	1.03	1.04	1.05	1.06
Internal exchanger Glycol solution flow Factor	Nr	1.01	1.02	1.04	1.05	1.07	1.09	1.11	1.13
Pressure drop Factor	Nr	1.02	1.05	1.08	1.12	1.16	1.21	1.26	1.32

The correction factors shown refer to water and glycol ethylene mixes used to prevent the formation of frost on the exchangers in the water circuit during inactivity in winter.

* MAX. REDUCTION EXTERNAL EXCHANGER INLET WATER TEMPERATURE

FOULING CORRECTION FACTOR

m ² °C/W	INTERNAL EXCHANGER		EXTERNAL EXCHANGER	
	F1	FK1	F2	FK2
0.44 x 10 ⁻⁴	1.00	1.00	1.00	1.00
0.88 x 10 ⁻⁴	0.97	0.99	0.97	1.08
1.76 x 10 ⁻⁴	0.94	0.98	0.92	1.05

F1 = Cooling capacity correction factors

FK1 = Compressor power input correction factor

F2 = Cooling capacity correction factors

FK2 = Compressors input power correction factors

EXCHANGER OPERATING LIMITS

	INTERNAL EXCHANGER		EXTERNAL EXCHANGER	
	DPr (S - B)		DPr	DPw
	kPa		kPa	kPa
CLIVET (C)	2450	2450	2145	1600
PED (CE)	2450	2450	2145	1600

DPr = Maximum operating pressure on refrigerant side

DPw = Maximum operating pressure on water side

OVERLOAD AND CONTROL DEVICE CALIBRATION

		OPEN	CLOSED	VALUE
High pressure switch	kPa	1730	1170	-
Low pressure switch	kPa	70.0	170	-
Antifreeze protection	°C	3.0	5.5	-
High pressure safety valve	kPa	-	-	2000
Low pressure safety valve	kPa	-	-	1650
Max no. of compressor starts per hour	Nr	-	-	6
High compressor discharge temperature safety thermostat	°C	-	-	120

**Acoustic configuration: Standard (ST)/Extremely low noise(EN) / Energy efficiency: Efficiency class A
Internal exchanger (evaporator) pressure drop: ST(STANDARD)- EN**

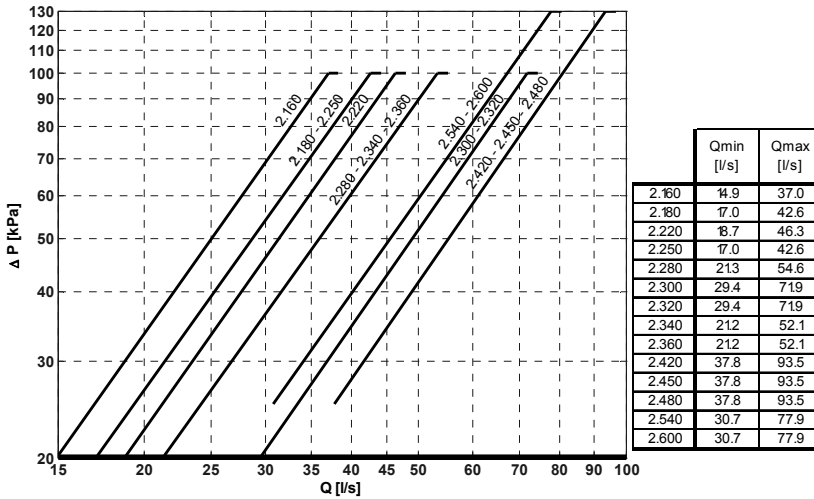

External exchanger pressure drop (condenser): ST (STANDARD)- EN

Tower water application

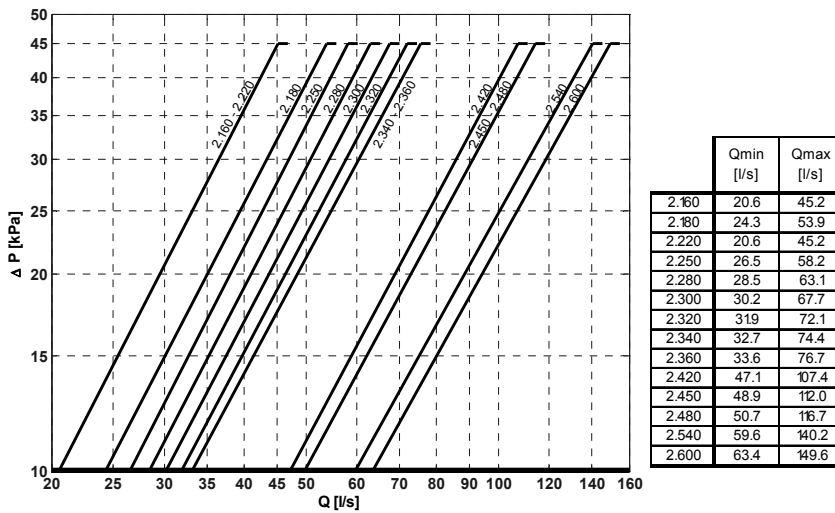

Well water application

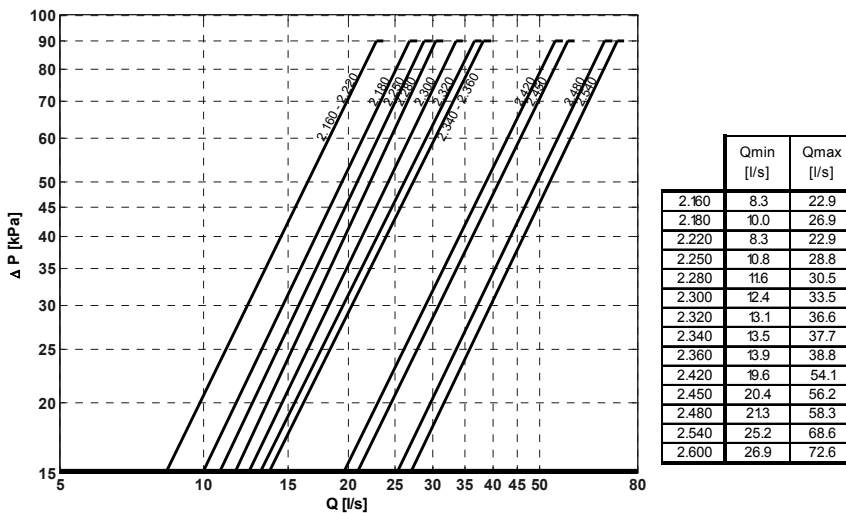

**Acoustic configuration: Standard (ST)/Extremely low noise(EN) / Energy efficiency: Efficiency class B
Internal exchanger (evaporator) pressure drop: ST(STANDARD)- EN**

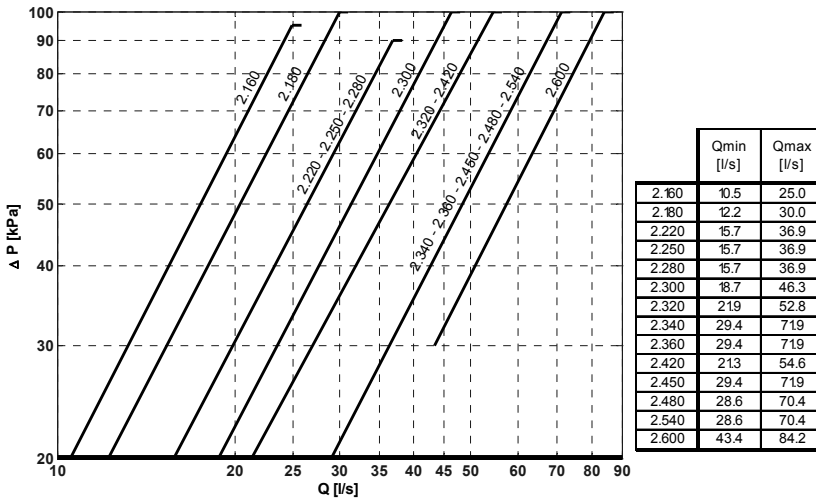

**External exchanger pressure drop (condenser): ST (STANDARD)- EN
Tower water application**

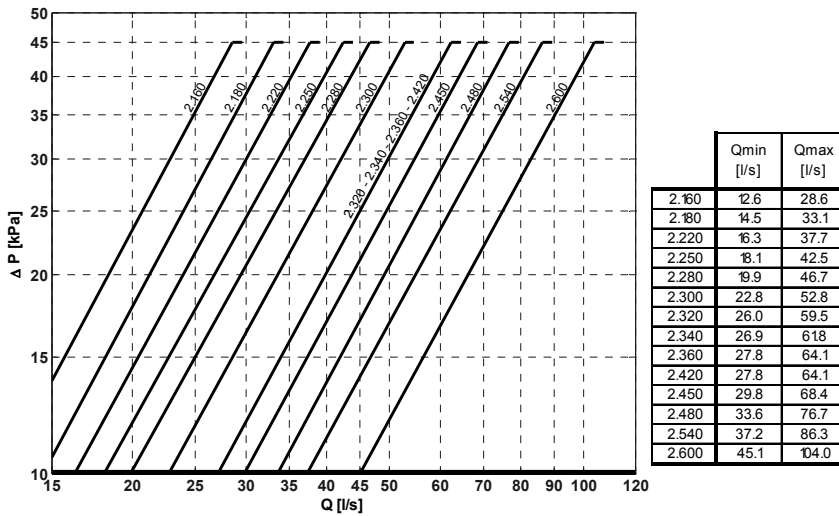

Well water application

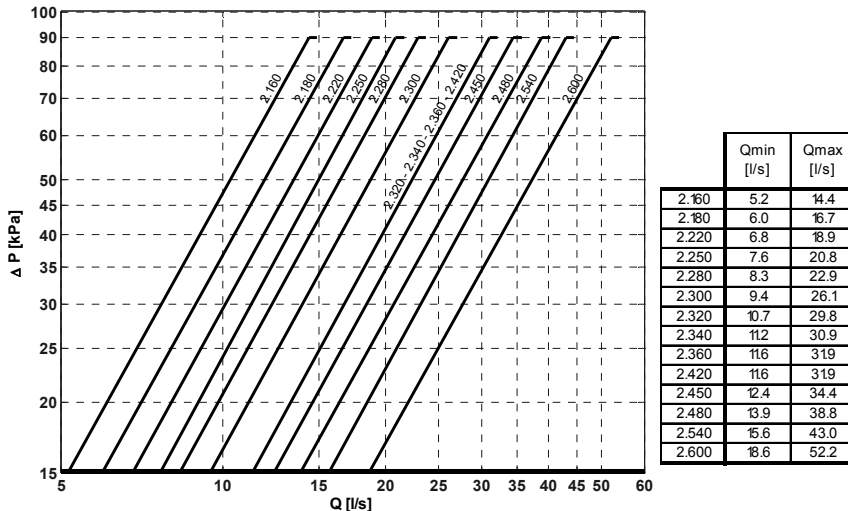

SOUND LEVELS

Acoustic configuration: Standard (ST) Energy efficiency: Efficiency class A										Acoustic configuration: Extremely low noise (EN) Energy efficiency: Efficiency class A											
Size	Sound Power Level (dB)								Sound pressure level	Sound power level	Size	Sound Power Level (dB)								Sound pressure level	Sound power level
	Octave band (Hz)											Octave band (Hz)									
	63	125	250	500	1000	2000	4000	8000	dB(A)	dB(A)		63	125	250	500	1000	2000	4000	8000	dB(A)	dB(A)
2.160	93	84	90	96	97	87	79	73	81	99	2.160	91	85	86	88	87	83	78	71	72	91
2.180	94	85	90	97	98	88	79	74	81	100	2.180	92	86	87	89	87	83	79	72	73	91
2.220	75	61	86	101	99	84	63	45	83	102	2.220	73	62	83	93	88	79	62	42	74	92
2.250	85	65	87	97	101	87	64	46	83	102	2.250	83	66	84	89	90	82	63	43	74	92
2.280	90	67	98	100	101	86	61	42	84	103	2.280	89	68	95	92	91	81	61	40	75	94
2.300	88	80	97	99	101	86	69	50	84	103	2.300	87	81	93	91	91	81	68	47	74	94
2.320	85	84	95	98	102	87	72	53	84	90	2.320	83	85	92	91	91	82	72	51	74	94
2.340	83	82	97	99	101	87	71	53	83	102	2.340	81	83	94	91	90	82	71	51	74	93
2.360	80	80	99	100	100	88	71	54	83	102	2.360	78	81	96	92	90	83	70	52	75	94
2.420	84	83	95	98	101	86	72	53	83	103	2.420	83	84	92	90	91	82	71	51	74	93
2.450	84	83	95	98	101	86	72	52	83	102	2.450	82	84	91	90	90	81	71	50	73	93
2.480	84	83	95	98	101	86	72	53	83	103	2.480	83	84	92	90	91	82	71	51	74	93
2.540	95	83	88	104	98	95	85	76	84	103	2.540	93	83	84	96	87	90	84	74	77	96
2.600	95	83	88	104	98	95	85	76	84	104	2.600	93	84	84	96	88	90	84	74	77	96

Measures according to ISO 3744 regulations, with respect to the EUROVENT 8/1 certification.
the sound levels refer to the unit at full load, in the rated test conditions.

The sound pressure level refers to a distance of 1m from the external surface of the units operating in an open field.

data referred to the following conditions :

internal exchanger water = 12/7°C

external exchanger water = 30/35°C

Acoustic configuration: Standard (ST) Energy efficiency: Efficiency class B										Acoustic configuration: Extremely low noise (EN) Energy efficiency: Efficiency class B											
Size	Sound Power Level (dB)								Sound pressure level	Sound power level	Size	Sound Power Level (dB)								Sound pressure level	Sound power level
	Octave band (Hz)											Octave band (Hz)									
	63	125	250	500	1000	2000	4000	8000	dB(A)	dB(A)		63	125	250	500	1000	2000	4000	8000	dB(A)	dB(A)
2.160	93	84	90	96	97	87	79	73	81	99	2.160	91	85	86	88	87	82	78	71	72	91
2.180	93	85	90	96	98	88	79	74	81	100	2.180	92	86	87	89	87	83	79	72	73	91
2.220	94	85	91	97	99	88	80	75	82	100	2.220	92	86	87	89	88	84	79	72	73	92
2.250	94	85	91	97	99	89	80	75	82	100	2.250	93	86	87	89	88	84	79	72	73	92
2.280	95	86	92	98	99	89	81	75	83	101	2.280	93	87	88	90	89	84	80	73	74	93
2.300	95	85	90	101	99	92	83	75	83	102	2.300	93	86	87	93	88	87	82	73	75	94
2.320	94	81	87	103	97	94	84	75	83	88	2.320	92	82	83	95	86	89	83	73	76	95
2.340	94	81	86	103	97	94	83	75	83	102	2.340	92	82	83	95	86	89	83	73	76	95
2.360	94	81	86	102	97	94	83	75	83	102	2.360	92	82	83	95	86	89	83	73	76	95
2.420	93	81	86	102	96	93	83	75	83	102	2.420	92	82	83	95	86	89	83	73	76	95
2.450	93	81	86	102	96	93	83	75	83	102	2.450	92	82	83	95	86	89	83	73	76	95
2.480	94	82	87	103	97	94	84	76	84	103	2.480	93	83	83	95	87	89	83	73	76	95
2.540	95	82	88	104	98	95	85	76	84	103	2.540	93	83	84	96	87	90	84	74	77	96
2.600	95	83	88	104	98	95	85	76	84	104	2.600	93	84	84	96	88	90	84	74	77	96

Measures according to ISO 3744 regulations, with respect to the EUROVENT 8/1 certification.

the sound levels refer to the unit at full load, in the rated test conditions.

The sound pressure level refers to a distance of 1m from the external surface of the units operating in an open field.

data referred to the following conditions :

internal exchanger water = 12/7°C

external exchanger water = 30/35°C

DIMENSIONS

ACOUSTIC CONFIGURATION: STANDARD (ST) / ENERGY EFFICIENCY: EFFICIENCY CLASS A

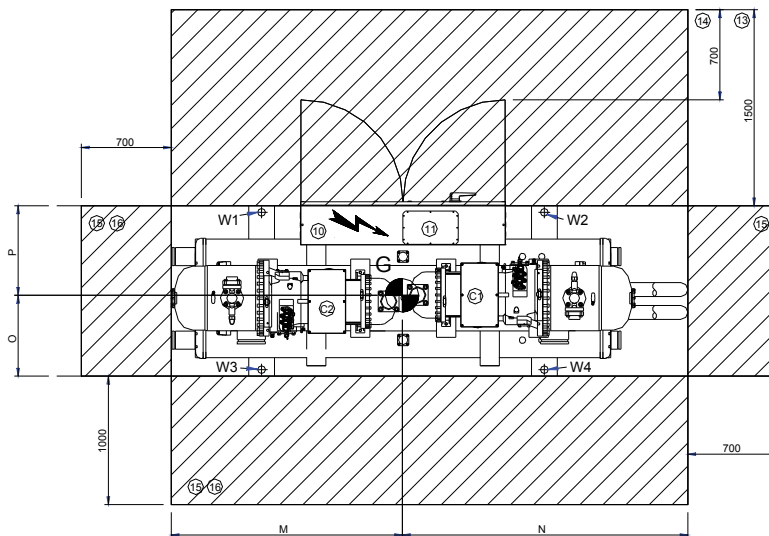
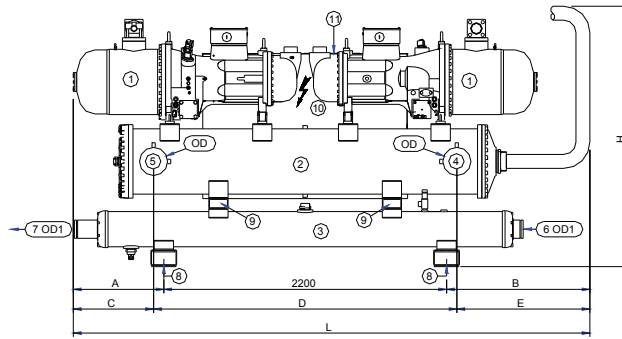
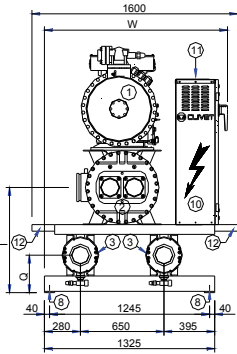

- (1) COMPRESSOR
- (2) INTERNAL EXCHANGER (EVAPORATOR)
- (3) EXTERNAL EXCHANGER (CONDENSER)
- (4) INTERNAL EXCHANGER WATER INLET
- (5) INTERNAL EXCHANGER WATER OUTLET
- (4 & 5) FITTINGS WITH FLEXIBLE JOINT AND SOLDER PIPE CONNECTION
- (6) EXTERNAL EXCHANGER WATER INLET
- (7) EXTERNAL EXCHANGER WATER OUTLET
- (6 & 7) FITTINGS WITH FLEXIBLE JOINT AND SOLDER PIPE CONNECTION
- (8) HOLE TO HANG UNIT
- (9) LIFTING HOLES
- (10) ELECTRICAL PANEL
- (11) POWER INPUT
- (12) LIFTING TUBE
- (13) MINIMUM DIMENSION ON THE ELECTRICAL SWITCHBOARD SIDE.
- (14) MINIMUM DIMENSION FOR A SAFE PASSAGE WHEN THE DOOR OF THE ELECTRICAL SWITCHBOARD IS OPEN
- (15) MINIMUM DIMENSION FOR A SAFE PASSAGE
- (16) MINIMUM DIMENSION FOR MAINTENANCE

		ST-CLA													
Size		2.160	2.180	2.220	2.250	2.280	2.300	2.320	2.340	2.360	2.420	2.450	2.480	2.540	2.600
A	mm	514	514	581	581	581	913	913	913	913	1006	1006	1006	1027	1027
B	mm	820	820	820	820	948	948	1248	1248	1248	1451	1451	1451	1451	1451
C	mm	408	408	475	475	501	833	833	833	833	652	652	652	522	522
D	mm	2412	2412	2412	2412	2360	2360	2360	2360	2360	2910	2910	2910	3210	3210
E	mm	714	714	714	714	868	868	1168	1168	1168	1095	1095	1095	946	946
H	mm	1711	1711	2018	2018	2018	2018	2018	2018	2018	2146	2146	2146	2146	2146
I	mm	781	781	781	781	819	819	819	819	819	883	883	883	883	883
L	mm	3534	3534	3601	3601	3729	4061	4361	4361	4361	4657	4657	4657	4678	4678
M	mm	1604	1602	1604	1673	1606	1865	2006	2007	2006	2120	2176	2119	2138	2139
N	mm	1930	1932	1997	1928	2123	2196	2355	2354	2355	2537	2481	2538	2540	2539
O	mm	625	643	696	636	634	631	627	627	628	614	613	613	625	625
P	mm	700	682	629	717	719	722	726	726	725	739	740	740	728	728
Q	mm	293	293	293	293	293	293	293	293	293	324	324	324	324	324
W	mm	1398	1398	1398	1425	1425	1425	1425	1425	1425	1425	1425	1425	1425	1425
OD	mm	168.3	168.3	168.3	168.3	219.1	219.1	219.1	219.1	219.1	219.1	219.1	219.1	219.1	219.1
OD1	mm	141.3	141.3	141.3	141.3	141.3	141.3	141.3	141.3	141.3	169.3	169.3	169.3	169.3	169.3
Length	mm	3534	3534	3601	3601	3729	4061	4361	4361	4361	4657	4657	4657	4678	4678
Depth	mm	1398	1398	1398	1425	1425	1425	1425	1425	1425	1425	1425	1425	1425	1425
Height	mm	1711	1711	2018	2018	2018	2018	2018	2018	2018	2146	2146	2146	2146	2146
W1	kg	694	733	1008	898	1050	1239	1204	1207	1215	1350	1299	1381	1423	1430
W2	kg	681	717	876	885	916	945	1189	1194	1199	1385	1475	1415	1452	1461
W3	kg	783	781	905	978	1151	1371	1349	1353	1357	1578	1523	1620	1605	1613
W4	kg	769	764	787	964	1004	1046	1332	1339	1340	1619	1730	1659	1638	1648
Operating weight	kg	2926	2995	3577	3726	4122	4602	5074	5093	5112	5931	6028	6075	6118	6152
Shipping weight	kg	2610	2689	3269	3416	3623	4107	4574	4590	4606	5344	5436	5478	5153	5475

Particular accessories, executions or versions can bring about a great variation of the mass represented here. Please contact our Technical Department.

ACOUSTIC CONFIGURATION: STANDARD (EN) / ENERGY EFFICIENCY: EFFICIENCY CLASS A

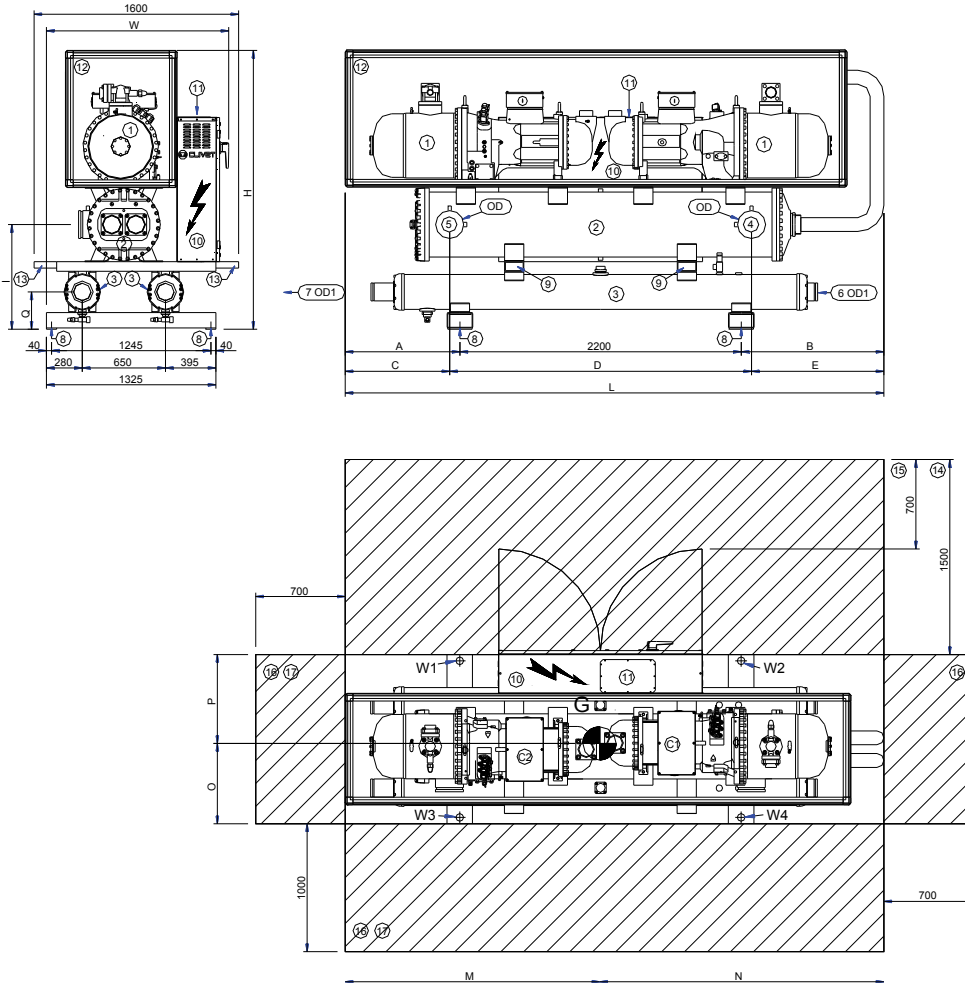

- (1) COMPRESSOR
- (2) INTERNAL EXCHANGER (EVAPORATOR)
- (3) EXTERNAL EXCHANGER (CONDENSER)
- (4) INTERNAL EXCHANGER WATER INLET
- (5) INTERNAL EXCHANGER WATER OUTLET
- (4 & 5) FITTINGS WITH FLEXIBLE JOINT AND SOLDER PIPE CONNECTION
- (6) EXTERNAL EXCHANGER WATER INLET
- (7) EXTERNAL EXCHANGER WATER OUTLET
- (6 & 7) FITTINGS WITH FLEXIBLE JOINT AND SOLDER PIPE CONNECTION
- (8) HOLE TO HANG UNIT
- (9) LIFTING HOLES
- (10) ELECTRICAL PANEL
- (11) POWER INPUT
- (12) SOUNDPROOFED CABIN
- (13) LIFTING TUBE
- (14) MINIMUM DIMENSION ON THE ELECTRICAL SWITCHBOARD SIDE
- (15) MINIMUM DIMENSION FOR A SAFE PASSAGE WHEN THE DOOR OF THE ELECTRICAL SWITCHBOARD IS OPEN
- (16) MINIMUM DIMENSION FOR A SAFE PASSAGE
- (17) MINIMUM DIMENSION FOR MAINTENANCE

		EN-CLA													
SIZE		2.160	2.180	2.220	2.250	2.280	2.300	2.320	2.340	2.360	2.420	2.450	2.480	2.540	2.600
A	mm	611	611	611	611	903	988	1098	1098	1098	1098	1098	1098	1098	1098
B	mm	1020	1020	1020	1020	1148	1148	1448	1448	1448	1451	1451	1451	1451	1451
C	mm	505	505	505	505	823	908	1018	1018	1018	743	743	743	594	594
D	mm	2412	2412	2412	2412	2360	2360	2360	2360	2360	2910	2910	2910	3210	3210
E	mm	914	914	914	914	1067	1068	1368	1368	1368	1093	1093	1093	942	942
H	mm	1891	1891	1891	1891	2182	2182	2182	2182	2182	2245	2245	2245	2245	2245
I	mm	781	781	781	781	819	819	819	819	819	883	883	883	883	883
L	mm	3831	3831	3831	3831	4250	4336	4746	4746	4746	4746	4746	4746	4746	4746
M	mm	1713	1706	1719	1710	1996	1946	2197	2197	2198	2215	2267	2215	2212	2213
N	mm	2118	2125	2112	2121	2254	2390	2549	2549	2548	2531	2479	2531	2534	2533
O	mm	615	625	625	633	632	626	623	623	623	611	610	610	621	621
P	mm	710	700	700	720	721	727	730	730	730	742	743	743	732	732
Q	mm	293	293	293	293	293	293	293	293	293	324	324	324	324	324
W	mm	1398	1398	1398	1425	1425	1425	1425	1425	1425	1425	1425	1425	1425	1425
OD	mm	168.3	168.3	168.3	168.3	219.1	219.1	219.1	219.1	219.1	219.1	219.1	219.1	219.1	219.1
OD1	mm	141.3	141.3	141.3	141.3	141.3	141.3	141.3	141.3	141.3	169.3	169.3	169.3	169.3	169.3
Length	mm	3831	3831	3831	3831	4250	4336	4746	4746	4746	4746	4746	4746	4746	4746
Depth	mm	1398	1398	1398	1425	1425	1425	1425	1425	1425	1425	1425	1425	1425	1425
Height	mm	1891	1891	1891	1891	2182	2182	2182	2182	2182	2245	2245	2245	2245	2245
W1	kg	750	784	910	966	1068	1307	1293	1298	1301	1438	1387	1467	1510	1516
W2	kg	753	777	923	964	1054	1008	1291	1295	1301	1487	1577	1518	1553	1562
W3	kg	874	885	1026	1062	1178	1470	1469	1474	1477	1697	1642	1738	1725	1733
W4	kg	877	877	1041	1060	1163	1134	1466	1471	1477	1755	1867	1797	1775	1786
Operating weight	kg	3254	3323	3900	4053	4463	4919	5519	5538	5557	6376	6473	6520	6563	6597
Shipping weight	kg	2938	3017	3592	3743	3964	4424	5019	5035	5051	5789	5881	5923	5598	5920

Particular accessories, executions or versions can bring about a great variation of the mass represented here. Please contact our Technical Department.

ACOUSTIC CONFIGURATION: STANDARD (ST) / ENERGY EFFICIENCY: EFFICIENCY CLASS B

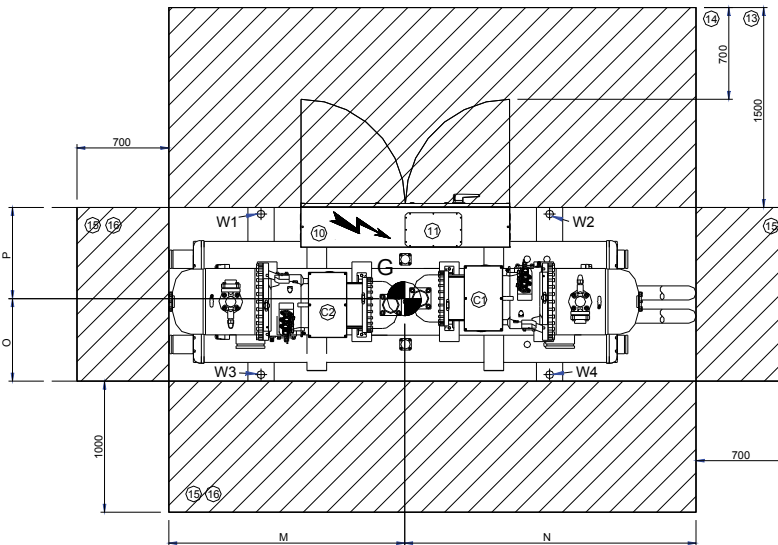
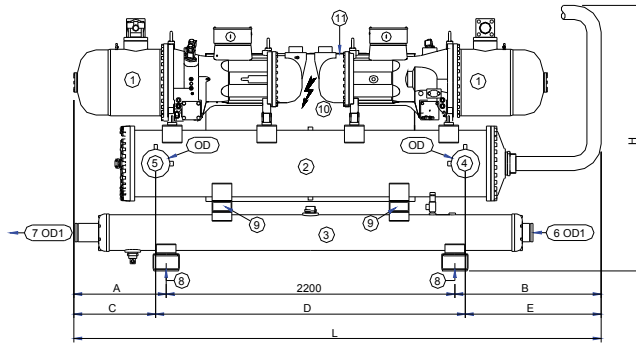
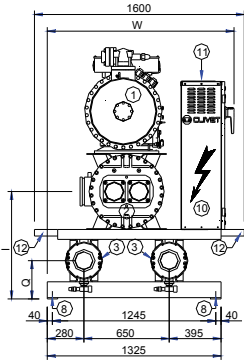

- (1) COMPRESSOR
- (2) INTERNAL EXCHANGER (EVAPORATOR)
- (3) EXTERNAL EXCHANGER (CONDENSER)
- (4) INTERNAL EXCHANGER WATER INLET
- (5) INTERNAL EXCHANGER WATER OUTLET
- (4 & 5) FITTINGS WITH FLEXIBLE JOINT AND SOLDER PIPE CONNECTION
- (6) EXTERNAL EXCHANGER WATER INLET
- (7) EXTERNAL EXCHANGER WATER OUTLET
- (6 & 7) FITTINGS WITH FLEXIBLE JOINT AND SOLDER PIPE CONNECTION
- (8) HOLE TO HANG UNIT
- (9) LIFTING HOLES
- (10) ELECTRICAL PANEL
- (11) POWER INPUT
- (12) LIFTING TUBE
- (13) MINIMUM DIMENSION ON THE ELECTRICAL SWITCHBOARD SIDE
- (14) MINIMUM DIMENSION FOR A SAFE PASSAGE WHEN THE DOOR OF THE ELECTRICAL SWITCHBOARD IS OPEN
- (15) MINIMUM DIMENSION FOR A SAFE PASSAGE
- (16) MINIMUM DIMENSION FOR MAINTENANCE

ST-CLB

SIZE		2.160	2.180	2.220	2.250	2.280	2.300	2.320	2.340	2.360	2.420	2.450	2.480	2.540	2.600
A	mm	515	515	514	514	514	794	705	705	705	705	705	1027	1027	1027
B	mm	811	811	820	820	820	939	989	997	997	997	997	1451	1451	1451
C	mm	390	390	408	408	408	688	599	624	624	624	624	672	672	672
D	mm	2460	2460	2412	2412	2412	2412	2412	2360	2360	2360	2360	2910	2910	2910
E	mm	676	676	714	714	714	833	883	918	918	918	918	1096	1096	1096
H	mm	1640	1640	1871	1871	1871	1980	1980	2083	2083	2083	2083	2083	2083	2146
I	mm	710	710	781	781	781	781	781	819	819	819	819	819	819	883
L	mm	3526	3526	3534	3534	3534	3933	3894	3902	3902	3902	3902	4678	4678	4678
M	mm	1606	1605	1605	1611	1606	1924	1879	1788	1788	1789	1788	2127	2127	2145
N	mm	1920	1921	1929	1923	1928	2009	2015	2114	2114	2113	2114	2551	2551	2533
O	mm	639	638	621	619	631	623	623	620	621	632	620	629	629	626
P	mm	686	687	704	734	722	730	730	733	732	721	733	724	724	727
Q	mm	293	293	293	293	293	293	293	293	293	293	293	293	293	324
W	mm	1398	1398	1398	1425	1425	1425	1425	1425	1425	1425	1425	1425	1425	1425
OD	mm	139.7	139.7	168.3	168.3	168.3	168.3	168.3	219.1	219.1	219.1	219.1	219.1	219.1	219.1
OD1	mm	141.3	141.3	141.3	141.3	141.3	141.3	141.3	141.3	141.3	141.3	141.3	141.3	141.3	168.3
Length	mm	3526	3526	3534	3534	3534	3933	3894	3902	3902	3902	3902	4678	4678	4678
Depth	mm	1398	1398	1398	1425	1425	1425	1425	1425	1425	1425	1425	1425	1425	1425
Height	mm	1640	1640	1871	1871	1871	1980	1980	2083	2083	2083	2083	2083	2083	2146
W1	kg	625	633	753	761	790	833	871	1033	1037	1064	1074	1274	1276	1361
W2	kg	615	622	741	757	778	879	997	1001	1006	1033	1042	1274	1276	1407
W3	kg	674	685	861	875	874	945	989	1184	1185	1174	1232	1418	1421	1531
W4	kg	663	673	847	871	861	999	1132	1148	1149	1140	1194	1418	1421	1582
Operating weight	kg	2576	2612	3201	3264	3304	3656	3988	4367	4377	4411	4542	5384	5393	5881
Shipping weight	kg	2368	2405	2884	2947	2981	3333	3654	3871	3881	3902	4036	4795	4800	5283

Particular accessories, executions or versions can bring about a great variation of the mass represented here. Please contact our Technical Department.

ACOUSTIC CONFIGURATION: STANDARD (EN) / ENERGY EFFICIENCY: EFFICIENCY CLASS B

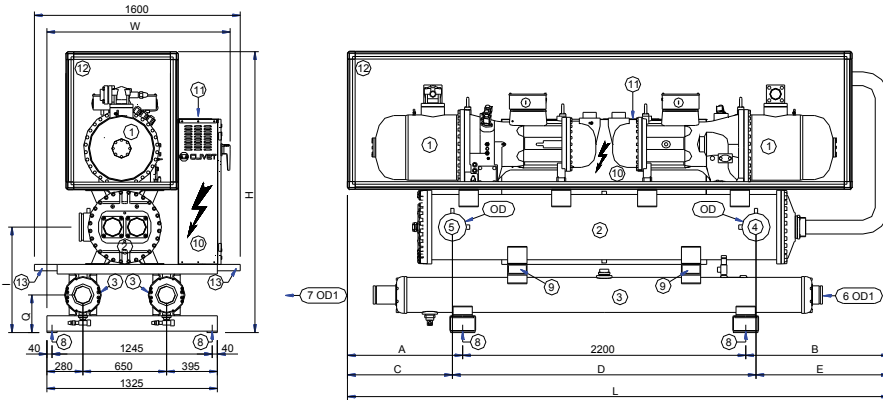

- (1) COMPRESSOR
- (2) INTERNAL EXCHANGER (EVAPORATOR)
- (3) EXTERNAL EXCHANGER (CONDENSER)
- (4) INTERNAL EXCHANGER WATER INLET
- (5) INTERNAL EXCHANGER WATER OUTLET
- (4 & 5) FITTINGS WITH FLEXIBLE JOINT AND SOLDER PIPE CONNECTION
- (6) EXTERNAL EXCHANGER WATER INLET
- (7) EXTERNAL EXCHANGER WATER OUTLET
- (6 & 7) FITTINGS WITH FLEXIBLE JOINT AND SOLDER PIPE CONNECTION
- (8) HOLE TO HANG UNIT
- (9) LIFTING HOLES
- (10) ELECTRICAL PANEL
- (11) POWER INPUT
- (12) SOUNDPROOFED CABIN
- (13) LIFTING TUBE
- (14) MINIMUM DIMENSION ON THE ELECTRICAL SWITCHBOARD SIDE
- (15) MINIMUM DIMENSION FOR A SAFE PASSAGE WHEN THE DOOR OF THE ELECTRICAL SWITCHBOARD IS OPEN
- (16) MINIMUM DIMENSION FOR A SAFE PASSAGE
- (17) MINIMUM DIMENSION FOR MAINTENANCE

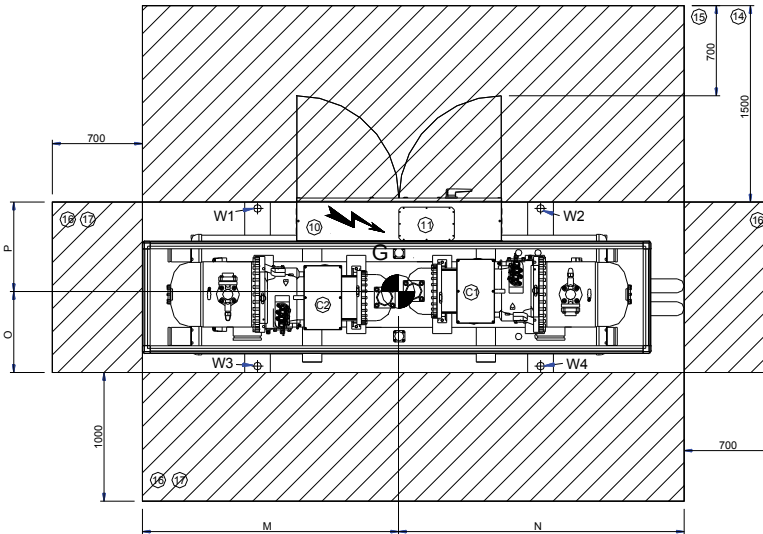

EN-CLB

SIZE		2.160	2.180	2.220	2.250	2.280	2.300	2.320	2.340	2.360	2.420	2.450	2.480	2.540	2.600
A	mm	608	608	611	611	611	894	894	868	868	868	868	1098	1098	1098
B	mm	1012	1012	1020	1020	1020	1139	1139	1248	1248	1248	1248	1451	1451	1451
C	mm	483	483	505	505	505	788	788	788	788	788	788	743	743	743
D	mm	2460	2460	2412	2412	2412	2412	2412	2360	2360	2360	2360	2910	2910	2910
E	mm	877	877	914	914	914	1033	1033	1168	1168	1168	1168	1096	1096	1096
H	mm	1781	1781	1891	1891	1891	2106	2106	2182	2182	2182	2182	2182	2182	2245
I	mm	710	710	781	781	781	781	781	819	819	819	819	819	819	883
L	mm	3820	3820	3831	3831	3831	4233	4233	4316	4316	4316	4316	4749	4749	4749
M	mm	1716	1717	1716	1718	1716	2031	1990	1965	1964	1989	1969	2204	2204	2219
N	mm	2115	2114	2115	2113	2115	2202	2243	2351	2352	2327	2347	2545	2545	2530
O	mm	637	645	621	632	631	617	617	618	618	629	618	624	624	622
P	mm	688	680	704	721	722	736	736	735	735	724	735	729	729	731
Q	mm	293	293	293	293	293	293	293	293	293	293	293	293	293	324
W	mm	1398	1398	1398	1425	1425	1425	1425	1425	1425	1425	1425	1425	1425	1425
OD	mm	139.7	139.7	168.3	168.3	168.3	168.3	168.3	219.1	219.1	219.1	219.1	219.1	219.1	219.1
OD1	mm	141.3	141.3	141.3	141.3	141.3	141.3	141.3	141.3	141.3	141.3	141.3	141.3	141.3	168.3
Length	mm	3820	3820	3831	3831	3831	4233	4233	4316	4316	4316	4316	4749	4749	4749
Depth	mm	1398	1398	1398	1425	1425	1425	1425	1425	1425	1425	1425	1425	1425	1425
Height	mm	1781	1781	1891	1891	1891	2106	2106	2182	2182	2182	2182	2182	2182	2245
W1	kg	720	738	819	853	858	891	1002	1092	1095	1101	1132	1360	1362	1450
W2	kg	726	746	827	864	866	953	995	1086	1087	1143	1134	1375	1377	1507
W3	kg	781	780	937	941	949	1031	1160	1260	1264	1226	1306	1539	1541	1652
W4	kg	788	789	945	953	958	1103	1152	1253	1255	1273	1309	1556	1558	1717
Operating weight	kg	3016	3052	3528	3611	3631	3977	4309	4691	4702	4743	4881	5829	5838	6326
Shipping weight	kg	2808	2845	3211	3294	3308	3654	3975	4195	4206	4234	4375	5240	5245	5728

Particular accessories, executions or versions can bring about a great variation of the mass represented here. Please contact our Technical Department.

CLIVET SPA
Feltre (BL) ITALY
Tel. + 39 0439 3131
Fax + 39 0439 313300
info@clivet.it

CLIVET ESPAÑA S.A.
Madrid - SPAIN
Tel. + 34 91 6658280
Fax + 34 91 6657806
info@clivet.es

CLIVET UK LTD
Fareham (Hampshire) U.K.
Tel. + 44 (0) 1489 572238
Fax + 44 (0) 1489 573033
info@clivet-uk.co.uk

CLIVET NEDERLAND B.V.
Amersfoort - Netherlands
Tel. + 31 (0) 33 7503420
Fax + 31 (0) 33 7503424
info@clivet.nl

CLIVET SPA
BUREAU DE LIAISON EN FRANCE
Verrières le Buisson - FRANCE
Tel. + 33 (0)1 69 20 25 75
Fax + 33 (0)1 69 20 60 76
info.fr@clivet.com

CLIVET GmbH
Norderstedt - GERMANY
Tel. +49 (0) 40 32 59 57-0
Fax +49 (0) 40 32 59 57-194
info.de@clivet.com

CLIVET TFAIR SYSTEMS (P) LTD.
Matur - INDIA
Tel. +91 8151 232683/5
Fax +91-8151-232684
info@clivetffa.com

The data contained in this bulletin is not binding and may be changed by the manufacturer without prior notice. All reproduction, even partial, is PROHIBITED.

© COPYRIGHT - CLIVET S.P.A. - FELTRE (BL) - ITALIA