

Air-Cooled Mini Chiller

Models: MAC 080 C/CR M4AC 080 C/CR
MAC 100 C/CR M4AC 100 C/CR
MAC 120 C/CR M4AC 120 C/CR
MAC 150 C/CR M4AC 150 C/CR



Contents

Nomenclature.....	2
General Features and Specifications.....	2 - 3
Chiller Panel Controller	4 - 35
Specifications	36 - 39
Performance Table	40 - 45
Technical Data	46 - 47
Outlines and Dimensions.....	48 - 50
Wiring Diagrams	51 - 54
Special Precautions for R407C.....	55 - 56
Installation	57 - 61
Servicing and Maintenance	62
Troubleshooting	63
Schematic Diagram	64
Parts List and Exploded View.....	65 - 66

Note: Installation and maintenance are to be performed only by qualified personnel who are familiar with local codes and regulations, and experienced with this type of equipment,

Caution: Sharp edges and coil surfaces are a potential injury hazard. Avoid contact with them.

Warning: Moving machinery and electrical power hazards. May cause severe personal injury or death. Disconnect and lock off power before servicing equipment.

"McQuay" is a registered trademark of McQuay International. All rights reserved throughout the world.

©2003 McQuay International

"Bulletin illustrations cover the general appearance of McQuay International products at the time of publication and we reserve the right to make changes in design and construction at any time without notice."

Nomenclature

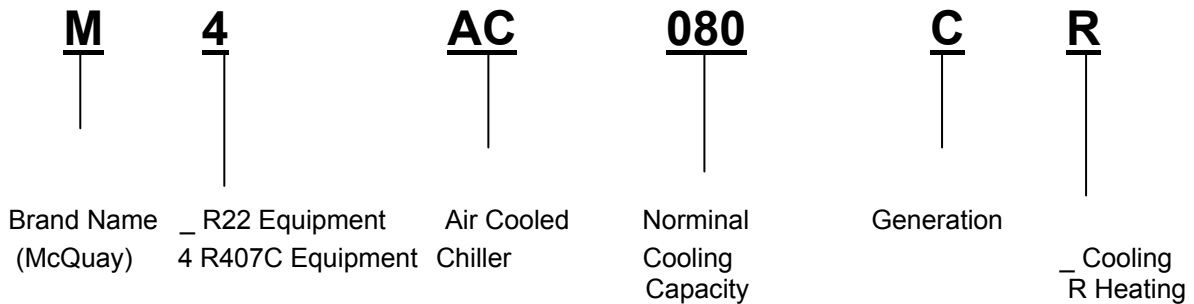

General Features and Specifications

Refrigerant circuit

The unit has been designed with two separate refrigerant circuits, i.e. it has two compressors. By doing so, the unit has part loading capabilities, i.e. 0-50-100% of rated capacity. This will improve the reliability and energy efficiency of the unit, especially during low loading operations. Each circuit is factory brazed and evacuated before accurately charged with refrigerant to ensure optimum performance. Because each circuit is separated, there is no danger of crosscontamination should either one of the compressors experiences a burnt-up. Each circuit is also equipped with a carefully sized thermostatic expansion valve (for cooling only units) to give optimum performance characteristics. For the heat pump versions, the expansion process is done with capillary tubes.

Scroll compressors are used in the unit to give quiet and reliable performance over a wide operating temperature range. However, in order to protect the compressors from damage, a phase protector is provided to prevent the compressors from rotating in the wrong direction.

Condenser Fan Motor

The unit is equipped with two high air flow propeller fan blades which are made of metal. The fans are directly driven by weather proof motors, the motors are of single phase type.

Evaporator

The heat exchanger is made of stainless steel plates closely arranged and brazed together (BPHE) to ensure high heat exchange efficiency. The water flows through the BPHE in a channel on its own, while because of the two compressors, the refrigerant flows through another two separate channels. The refrigerant will either be in a counter-flow or parallel-flow with respect to the water, depending on the mode of operation (cooling or heating).

Safety Protection

The safety protections provided for in the chiller unit are:

- a) High and low pressure switches
- b) Differential water flow switch
- c) Compressor, water pump and fan motor overload protectors
- d) Anti-freeze protection sensor

During abnormal condition, the electronic controller will turn off the unit and then display the fault of operation.

Other than that, the unit also has pressure gauges (analog) for each compressor suction and discharge pipes. These are useful for detecting abnormal operating conditions, especially during maintenance services.

Water buffer tank & pipe connection

The unit does not come with a water buffer tank. However, the unit does come with an 8 liters expansion tank.

(A 135L water tank is available as optional item)

The external water piping connection can be made either from the left or right side of the unit. Connection is done with ϕ 1-1/4" female thread couplings for both supply and return pipes.

Anti-freeze protection

The chiller unit has several anti-freeze protection features:

1. Brazed plate heat exchanger anti-freeze

The BPHE has a strip heater around it to prevent water freezing inside.

2. Auto mode

The chiller controller will force-on the unit to the heat mode if the outdoor ambient air temperature becomes too cold.

Maintenance

In order to facilitate maintenance of the controller, a rocker switch is provided to power-off the supply to the PCB. However, switching off this switch will not disconnect the main incoming power supply to the chiller unit.

Coil Guard

The unit also comes with two sets of coil guards (i.e. on the left and right side coils). Each guard is basically a metal mesh which protects the coil from damage due to a side impact on the coil surface itself.

Fin Coating

The finned tube heat exchanger coil used on the chiller unit is made of staggered rows of 3/8" seamless copper tubes, mechanically expanded into die-formed louvered fins. The slit openings on the fins enhance the heat transfer coefficient between the fin surfaces and air.

In order to protect these fins from corrosion, a special fin coating (gold fin) is applied on the surface. This coating is standard on the heat pump version, whereas it is an option on the cooling only model.

Chiller Panel Controller

1. SAFETY CONSIDERATION

Only specially trained and qualified technicians and installers are authorized to install and service this equipment.

1.1 General Installation Recommendations

- Only supply DC voltage (9-17V, typically 12V, maximum current 200mA) as a power source to the device.
- Input contact voltage supply should limit to 12VDC or 24VAC.
- Isolated all the low voltage wiring (communication bus, etc.) from high voltage power supply wiring.

2. GENERAL DESCRIPTION

2.1 General

The Chiller Panel Controller is designed to control the Chiller operation. This device allows the user to have customized control for each connected unit.

2.2 Features

The requirements of user friendly and easy to use have been taken into account in designing this Chiller Panel Controller. It can do the task as follow:

- Whole system configuration
- Unique parameter settings
- Operation status display
- Tracing fault record (easy in hardware troubleshooting)

The display is shown in an 8-line graphical LCD display. There are 8 dedicated keys available in the panel, which allow user to do the following task:

- Menu selection
- Navigation on the screen
- Modification of the selected value

During first start-up, the panel will have a default configuration (timer schedule, set point, miscellaneous settings, etc). User can do the changes on that particular configuration later.

2.3 Panel Position

The Chiller Panel Controller can be installed anywhere, as long as it is easy to accessed by authorized personnel.

The requirements of installation are:

- Avoid exposure to shocks
- Avoid any source of electromagnetic pollution
- Avoid installation on uneven vertical surface

2.4 Operation Environmental Condition

- Temperature:
 - 10°C to 65°C Operating Temperature
 - 20°C to 85°C Storage Temperature
- Relative Humidity:
 - 0 to 95% Non - Condensing

3. HARDWARE DESCRIPTION

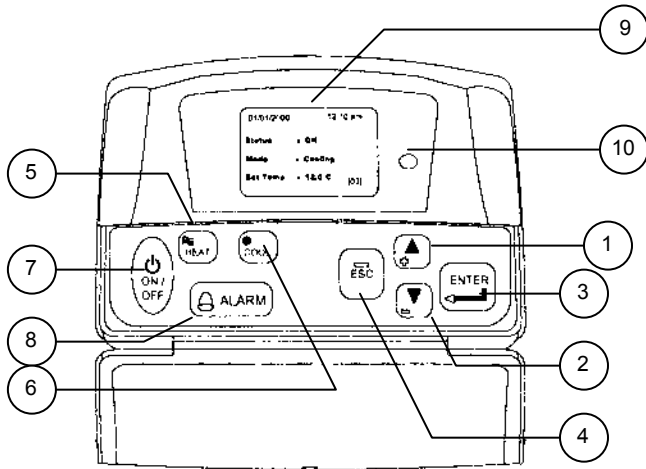

Front View

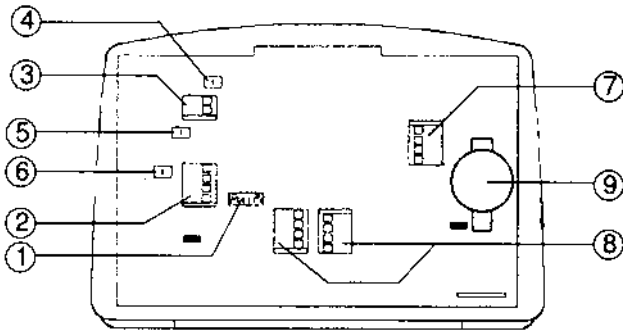

Back View

Legend

1 & 2	Navigation key
3	Execute instruction key
4	Cancel instruction key
5	Switching to Heat mode shortcut key
6	Switching to Cool mode shortcut key
7	Toggle ON/OFF shortcut key
8	Show alarm key
9	Graphical LCD display
10	ON/OFF indicator

Legend

1 & 2	Chiller terminal unit connection
3	Not available
4	CMOS reset jumper (JH2)
5	Chiller bus resistor configuration (JH3)
6	Not available
7	Not available
8	Not available
9	Backup battery

3.1 Key Explanation



The 2 navigation keys permit item selection and modifying the selected value.



ENTER key is used to execute the navigation instruction



ESC key is used to cancel the navigation instruction



Shortcut key to switch the operation mode in the Summary Pages



Shortcut key to trigger ON/OFF in the Summary Pages

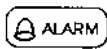

Shortcut key to show fault / alarm in the Summary Pages

4. INSTALLATION

4.1 Chiller Bus

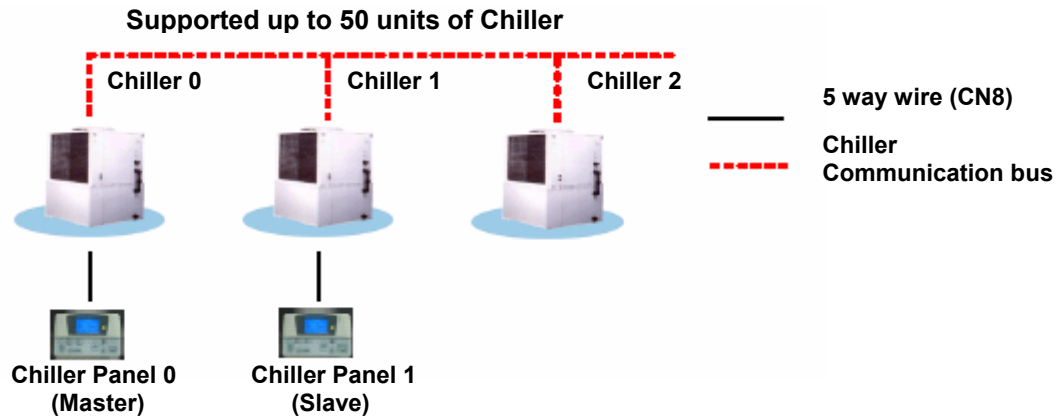

CHILLER NETWORK

Chiller panel needs to be energized with +12Vdc. The 5 way wires that provided is once on the easiest solution to establish a communication between the panel and chiller main board (CN8-CN8). If the 5-way wires socket has been occupied in main board, just using 2 insulation wires connected to the +12Vdc and GND terminal block from main board to panel can still energize a panel. Beside that, another 2 insulation wired are needed to establish a communication between panel and chiller main board.

Chiller panel can support maximum up to 50 units of chiller. In the chiller network, duplication of main board unit address is not allowed. Each chiller main board should have their unique unit address (0 – 50). For first time running, user need to assign a unique unit address to each main board in the chiller network. User should follow the procedure below:

- Only power ON one main board at once time. Make sure not others main boards are energized.
- By using the panel connected to the main board.

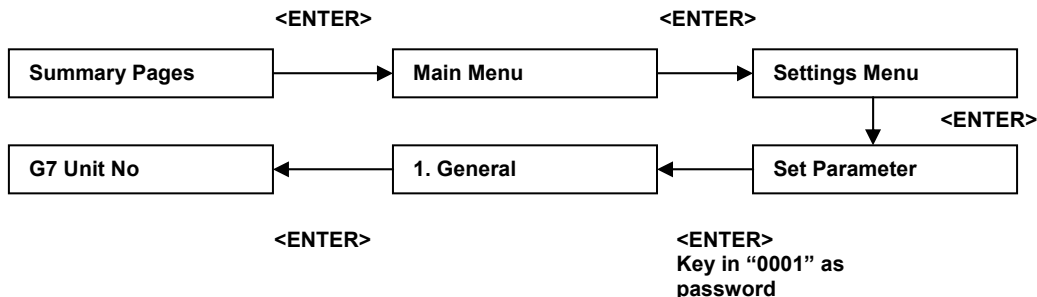

- Key in a unique unit address and press ENTER to execute.
- De-energized the main board and repeat the procedures again until all the main boards have been assigned a unique unit address

IMPORTANT: Do not assign a same unit address to more than one chiller main board.

RECOMMENDATION: Please select a coherent model (G1 Model) to all the chiller main boards in the same network

4.2 Others Configuration

- JH2 in Chiller panel should let it open (put the jumper header on one pin only) all the time unless user need to do CMOS reset to that particular panel.
- JH3 should let it open (put the jumper header on one pin only) all the time as well.
- Remember to put in the coin cell battery on the panel. Without the backup battery, the panel will always reset the time to 12:00am, 1st Jan 2000.

4.3 Installation of the Chiller Panel Controller

- Disconnect the unit and ensure no others unit energy source that supplies the panel.
- Open the rear panel of the Chiller Panel (insert a 'flat-head' screwdriver in the top joint of main casing with rear panel to open the rear panel)
- Pass the necessary wires of the panel across the large opening in the rear panel. Place the rear panel flat support against the wall and make marks on the wall through the four installation holes (inner or outer).
- Drill four appropriate holes in the marked places.
- Attach the rear panel to the wall and put on the screws on it. Ensure that all cables are passed through the hole of the rear panel.
- Connect the wires to the corresponding terminal according to the wiring bus network. The power supply and communication wires must be correctly connected to ensure that the panel works.
- Close the Chiller panel (ensure the bottom joint is aligned for the casing, then complete others joint part. Ensure that the contacts at the back of the panel are aligned with each others)

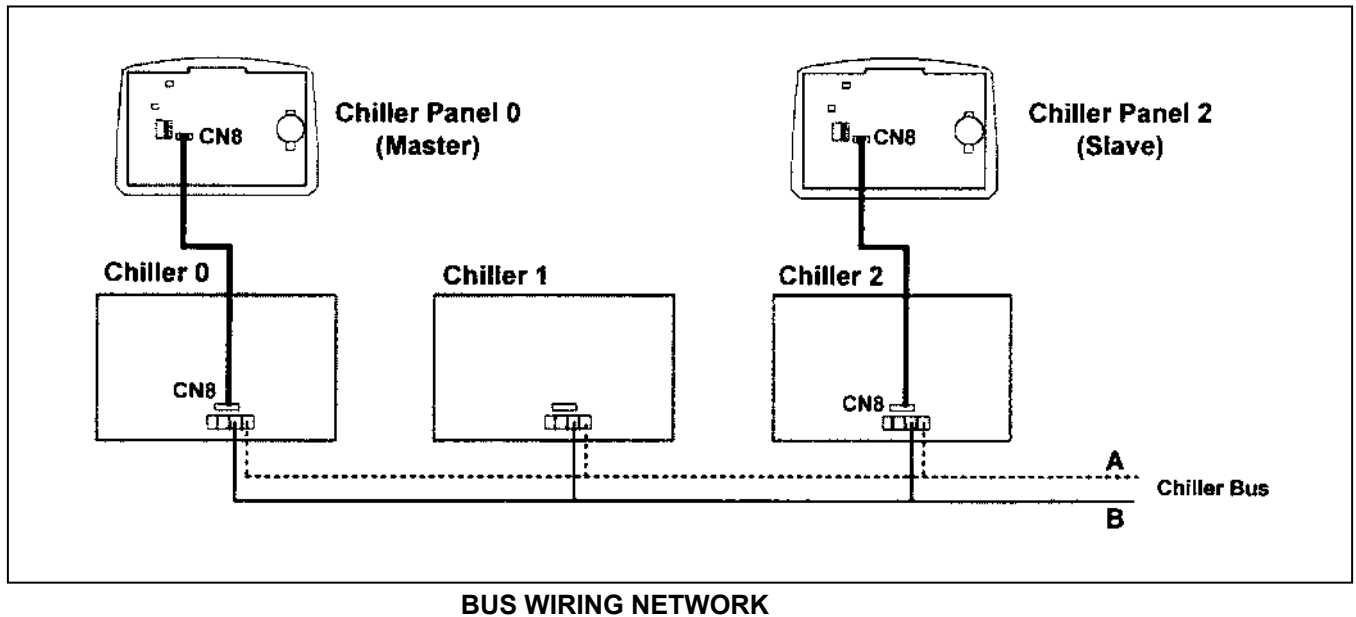

5. SOFTWARE DESCRIPTION

5.1 Introduction

The Chiller Panel Controller can be used to control/display the status of Chiller.

Status viewing:

- ON/OFF status
- Mode (Cooling/Heating/Boiling)
- Mode set temperature
- Compressor status (ON/OFF/DEFROST)
- Water in, Water out, Outdoor air and Panel temperature
- Chiller Model (Chiller, Heat Pump, Chiller/Boiler, Chiller+Boiler, Heat Pump/Boiler, Heat Pump+Boiler)
- Advance Parameter settings
- Defrost sensor temperatures
- Compressor Discharge sensor temperatures
- Compressor run times
- Incoming alarm/fault/error

Status settings:

- ON/OFF switching
- Mode setting (Cooling/Heating/Boiling)
- Mode set temperature
- Manual entering defrost
- Advance Parameter settings
- Password changing
- Panel Option setting (Backlight, Alarm Buzzer, Screen saver, Contrast, Brightness, temperature unit)
- Time and Date settings
- 7 day programmable settings
- Clearing compressor run time

5.2 Menu Structure

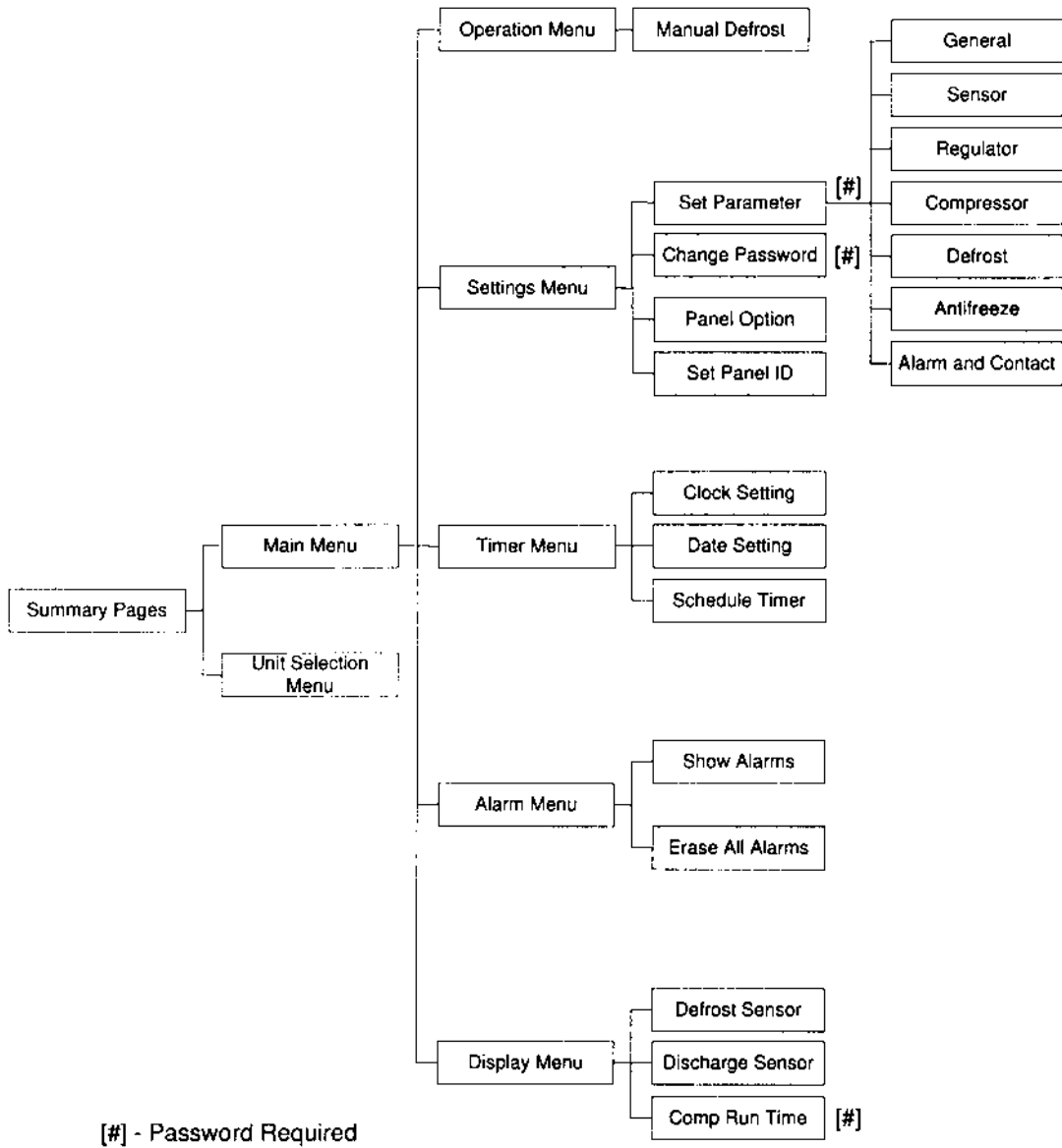

Menu Structure Diagram for Chiller

5.3 Chiller Menu Structures

5.3.1 Summary Pages

There are 4 pages in [Summary Pages]. Press **UP** or **DOWN** for page scrolling. Press **ENTER** to go into [Main Menu].

Time and date are shown on top of each page. Beside that, the bottom of each page shows current control unit of the Chiller.

For example: [00] – Chiller Panel controls Chiller ID 0 currently
[03] – Chiller Panel controls Chiller ID 3 currently
[All] – Chiller Panel controls all Chiller currently

1st page: Display ON/OFF status, Mode Settings and Temperature settings.

01/01/2000	12:00am
Status	: ON
Mode	: Cooling
Cool Temp	: 12.0°C
	[00]

2nd page: Display Compressor status.

01/01/2000	12:00am
Compressor 1	: ON
	[00]

3rd page : Display Water In, Water Out, Outdoor Air and Panel temperatures.

01/01/2000	12:00am
Water In	: 19.8°C
Water Out	: 25.6°C
Outdoor Air	: 32.2°C
Panel	: 20.5°C
	[00]

4th page : Display Chiller model, Compressor No. and Chiller ID.

01/01/2000	12:00am
Model	: Chiller
No. Comp	: 1 Comp
Unit No.	: 0
	[00]

5.3.2 Main Menu

Press **ENTER** in **[Summary Pages]** to go into this menu.

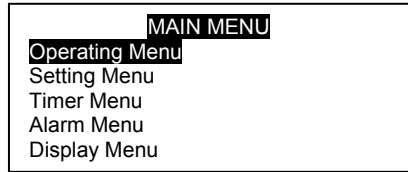

There are 5 sub menus in **[Main Menu]**. Press **UP** or **DOWN** to select sub menus, **ENTER** to enter into the sub menu or press **ESC** to exit to **[Summary Pages]**.

5.3.2.1 Operation Menu

Select **[Operation Menu]** in **[Main Menu]** and press **ENTER** to go into this menu.

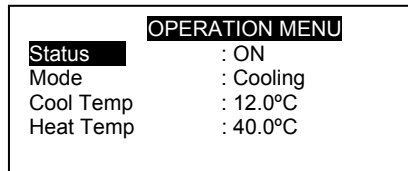

Some normal settings can be found here. Press **UP** or **DOWN** to select each settings, **ENTER** to start the setting or press **ESC** here to exit to **[Main Menu]**.

- Settings:
- ON/OFF unit
 - Mode changing (Cooling/Heating/Boiling)
 - Cooling temperature setting
 - Heating temperature setting
 - Manual Defrost Selection

5.3.2.1.1 Manual Defrost

Select **[Manual Defrost]** in **[Operation Menu]** and press **ENTER** to go into this menu.

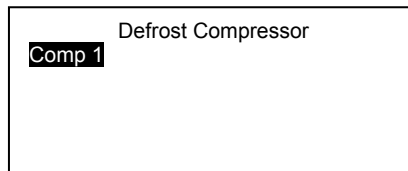

This menu lets user select one compressor to enter into defrost cycle manually, as long as the environment fulfill the defrost requirement.

5.3.2.2 Settings Menu

Select **[Settings Menu]** in **[Main Menu]** and press **ENTER** to go into this menu.

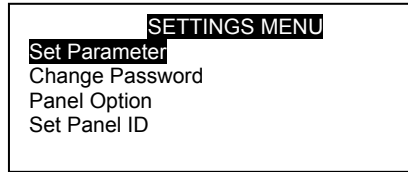

Some advance settings can be found here. Press **UP** or **DOWN** to select each settings, **ENTER** to start the setting or press **ESC** here to exit to **[Main Menu]**.

- Settings:
- Set Parameter
 - Password Changing
 - Panel Option
 - Set Panel ID

5.3.2.2.1 Set Parameter

Select **[Set Parameter]** in **[Settings Menu]** and press **ENTER** to go into this menu.

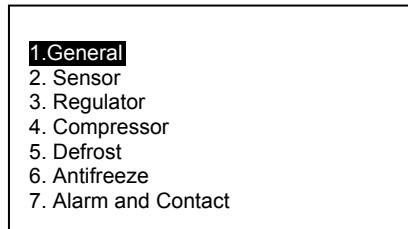

There are 7 groups of advance parameters for user to set in this menu. Press **UP** or **DOWN** to select the group, **ENTER** to go into the group or **ESC** to exit to **[Setting Menu]**.

- Settings: - General
- Sensor
 - Regulator
 - Compressor
 - Defrost
 - Antifreeze
 - Alarm and Contact

5.3.2.2.2 Password Changing

Select **[Password Changing]** in **[Settings Menu]** and press **ENTER** to go into this menu.

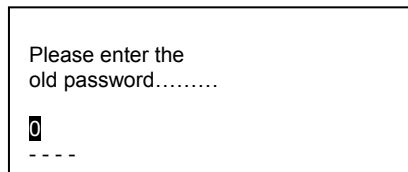

User can change the old password in this menu.

Press **ESC** to exit to **[Settings Menu]**.

5.3.2.2.3 Panel Option

Select [**Panel Option**] in [**Settings Menu**] and press **ENTER** to go into this menu.

Backlight	: Normal
Buzzer	: On
Screen Saver	: Disable
Timeout	: 5m
Contrast	: 50%
Brightness	: Medium
Temp Unit	: °C

User can do some miscellaneous settings for the panel. These settings would not affect whole system performance.

- Settings
- toggle Backlight
 - Alarm Buzzer
 - Enable/Disable Screen Saver
 - Screen Saver timeout
 - Contrast display
 - Backlight brightness
 - Temperature unit

Press **ESC** to exit to [**Settings Menu**].

5.3.2.2.4 Set Panel ID

Select [**Set Panel ID**] in [**Settings Menu**] and press **ENTER** to go into this menu.

<p>Please enter the Panel ID...</p> <p>=> Unit 0</p>

User can assign the ID no. to the panel.

Example: If ID no. 0 has been assigned, the panel acts like Master Panel Unit. It can choose to control each Chiller in the network.

If other ID no. (1-50) has been assigned, the panel acts like Slave Panel Unit. It is dedicated to one particular Chiller. It can only control the Chiller with same ID in the network.

Press [**ESC**] to exit to [**Settings Menu**].

5.3.2.3 Timer Menu

Select **[Timer Menu]** in **[Main Menu]** and press **ENTER** to go into this menu.

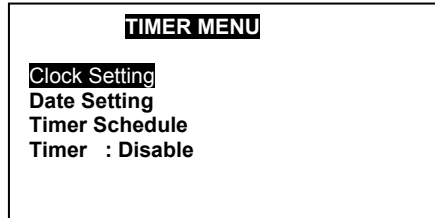

All the timer/schedule settings are included in this menu. Press **UP** or **DOWN** to select each settings, **ENTER** to start the setting or press **ESC** here to exit to **[Main Menu]**.

- Settings:
- Set Clock
 - Set Date
 - Set Schedule (7 days Programmable Timer)
 - Enable/Disable Timer Schedule

5.3.2.3.1 Set Clock

Select **[Clock Setting]** in **[Timer Menu]** and press **ENTER** to go into this menu.

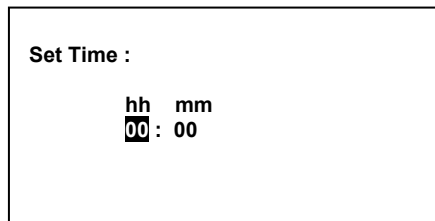

User can set the time in this menu. The time setting is in 24-hour format.

Press **[ESC]** to exit to **[Timer Menu]**.

5.3.2.3.2 Set Date

Select **[Date Setting]** in **[Timer Menu]** and press **ENTER** to go into this menu.

```
Set Date :  
  
  yyyy mm dd  
  2000 / 01 / 01
```

User can set the date in this menu. The date is set according to sequence below:

(year) / (month) / (day)

Press **[ESC]** to exit to **[Timer Menu]**.

5.3.2.3.3 Set Schedule

Select **[Schedule Timer]** in **[Timer Menu]** and press **ENTER** to go into this menu.

```
Timer 1   Timer 2  
ON  OFF  ON  OFF  
  
Sun 0800 1600 -----  
Mon 0800 1600 -----  
Tue 0800 1600 -----  
Wed 0800 1600 -----
```

This is the 7 days programmable timer schedule menu. There are 2 ON/OFF events in one day. User can choose to set each day of week (Sunday – Saturday) ON/OFF timer. Before this schedule carry their effect to the Chiller, user need to set the **[Timer]** in **[Timer Menu]** to **enable**.

Press **[ESC]** to exit to **[Timer Menu]**.

5.3.2.4 Alarm Menu

Select **[Alarm Menu]** in **[Main Menu]** and press **ENTER** to go into this menu.

```
ALARM MENU  
  
Show Alarms  
  
Erase All Alarms
```

This place keeps records for all previous occurred fault/alarms. User can view the alarm history and clear that record (alarm history) as well. The panel can keep up to 20 fault/alarm records.

Press **ESC** to exit to **[Main Menu]**.

5.3.2.4.1 Show Alarms

Select **[Show Alarms]** in **[Alarm Menu]** and press **ENTER** to go into this menu.

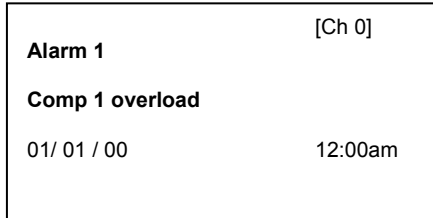

User can view all the fault/alarm records in this menu.

- The record shows
- Alarm type
 - Alarm occurred date
 - Alarm occurred time
 - Alarm occurred unit (Chiller ID)

Beside that, user can erase the alarm record in this menu.

Press **[ESC]** to exit to **[Alarm Menu]**.

5.3.2.4.2 Erase All Alarms

Select **[Erase All Alarms]** in **[Alarm Menu]** and press **ENTER** to go into this menu.

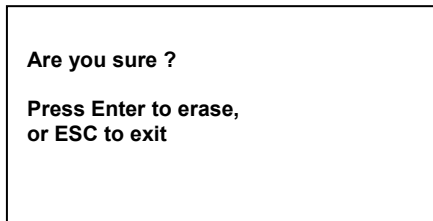

User can erase all the alarm/fault records at once in this menu.

Press **[ESC]** to exit to **[Alarm Menu]**.

5.3.2.5 Display Menu

Select **[Display Menu]** in **[Main Menu]** and press **ENTER** to go into this menu.

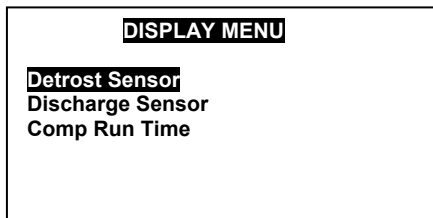

This menu displays Defrost Sensor temperature, Compressor Discharge sensor temperature and Compressor Run Time. Beside that, user can clear each Compressor Run Time for Chiller.

Press **ESC** to exit to **[Main Menu]**.

5.3.2.5.1 Defrost Sensor

Select **[Defrost Sensor]** in **[Display Menu]** and press **ENTER** to go into this menu.

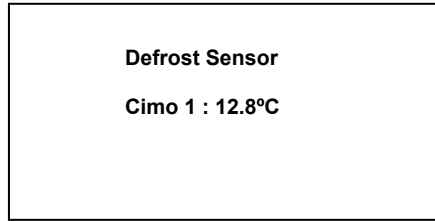

User can view the defrost sensor temperature for each compressor in the Chiller.

Press **[ESC]** to exit to **[Display Menu]**.

5.3.2.5.2 Discharge Sensor

Select **[Discharge Sensor]** in **[Display Menu]** and press **ENTER** to go into this menu.

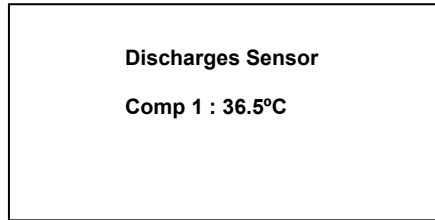

User can view the discharge sensor temperature for each compressor in the Chiller.

Press **[ESC]** to exit to **[Display Menu]**.

5.3.2.5.3 Comp Run Time

Select **[Comp Run Time]** in **[Display Menu]** and press **ENTER** to go into this menu.

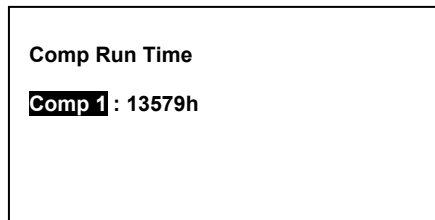

User can view the compressor run time for each compressor in the Chiller. Beside that, user can clear each compressor run time in this menu. User needs to key in the correct password before clearing the compressor run time.

Press **[ESC]** to exit to **[Display Menu]**.

6. OPERATION USER MANUAL

6.1 Starting

Chiller panel can be set as Master or Slave panel unit. When the Panel ID is set to '0', it acts like a Master panel, whereas it is Slave panel if Panel ID is set to others number (1-50).

Chiller panel can control the Chiller if both ID no. (Panel ID and Chiller ID) are same.

For example: Panel ID 1 can only control Chiller ID 1

Master Panel can choose to control each Chiller or control all Chiller at once in the network.

For example: Panel ID 0 (master) can control Chiller ID 0 / ID 1 / ID 32.... or all Chillers at once.

Panel ID can be set in **Set Panel ID** in **Settings Menu**:

Please enter the
Panel ID....

=> Unit 0

6.2 Chiller Operation Control

6.2.1 Starting

During power on for the Chiller Panel, it needs to take several times to collect information from the Chiller. At this time, all the status will show '--'. Please ensure the particular Chiller exists in the network. When the process is completed, user can start to control the Chiller using the panel.

01 / 01 /2000	12:00am
Status	: --
Mode	: --
Cool Temp	: --
	[00]

In gathering information process

01 / 01 /2000	12:00am
Status	: ON
Mode	: Cooling
Cool Temp	: 12.0°C
	[00]

Gathering information completed

6.2.2 Changing Display Unit

Chiller Panel (Master) can choose to control/display each Chiller status. This can be done in **[Summary Pages]** only.

01 / 01 /2000	12:00am
Status	: ON
Mode	: Cooling
Cool Temp	: 12.0°C
	[00]

*In [Summary Pages], press and hold **ENTER** button (1 second) to go into [Unit Selection] menu.*

Unit Selection	:
Select All	
Select One	: 0

*Select "**Select All**" and press **ENTER** if user want to control all Chiller in the network, or select "**Select One**" to control a particular Chiller. Press **ESC** to exit to [Summary Pages].*

Unit Selection	:
Select All	
Select One	: 0

*Select a Chiller ID via **UP** or **DOWN** and press **ENTER** to confirm or **ESC** to cancel.*

6.2.3 Switching ON/OFF

There are several ways to switch ON/OFF for the Chiller.

i) **[Summary Pages]**

Press and hold **ON/OFF** button (hold 1 second). Please note that the **ON/OFF** button will only function in **[Summary Pages]**.

ii) **[Operation Menu]**

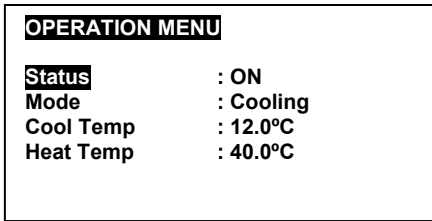
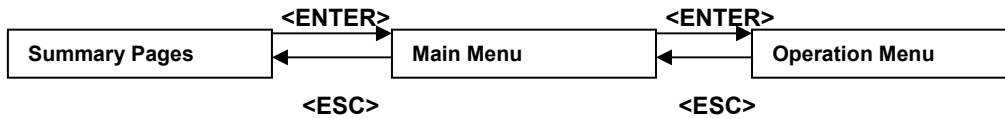

In [Operation Menu], select "Status" and press ENTER.

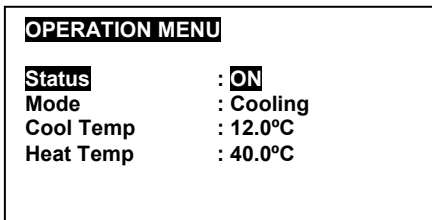

Toggle ON/OFF via UP or DOWN button, and then press ENTER to confirm the change or ESC to cancel.

iii) **[Timer Menu]**

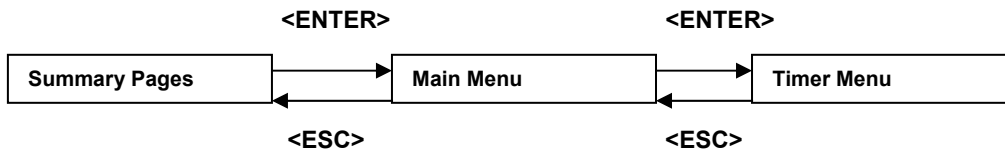

7 days programmable timer can turn chiller ON/OFF. User can set the schedule in this **[Timer Menu]**. Please refer **6.2.11 (page 27)** for schedule settings.

6.2.4 Switching Mode

There are several ways to switch the mode for the Chiller. Please take note that some mode cannot be set due to current Chiller model settings.

Chiller Model	Mode		
	Cooling	Heating	Boiling
Chiller	√	x	x
Heat Pump	√	√	x
Chiller / Boiler	√	X	√
Heat Pump / Boiler	√	√	√
Chiller + Boiler	√	x	Auto
Heat Pump+ Boiler	√	√	Auto

√ - Allow to set
 x - Not allow to set
 Auto - Turn ON automatically

i) [Summary Pages]

Cooling - Press and hold **COOL** button.

Heating - Press and hold **HEAT** button (if it allows to set).

Boiling - Press and hold **HEAT** button again (if it allows to set).

ii) [Operation Menu]

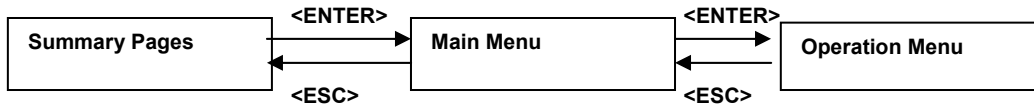

```

OPERATION MENU

Status      : ON
Mode        : Cooling
Cool Temp   : 12.0°C
Heat Temp   : 40.0°C
  
```

In [Operation Menu], select "Mode" and press ENTER to start setting or ESC to exit to [Main Menu].

```

OPERATION MENU

Status      : ON
Mode        : Cooling
Cool Temp   : 12.0°C
Heat Temp   : 40.0°C
  
```

Toggle ON/OFF via UP or DOWN button, and then press ENTER to confirm the change or ESC to cancel.

6.2.5 Changing Mode Set Temperature

There are 2 ways to change the mode set temperature for the Chiller.

i) [Operation Menu]

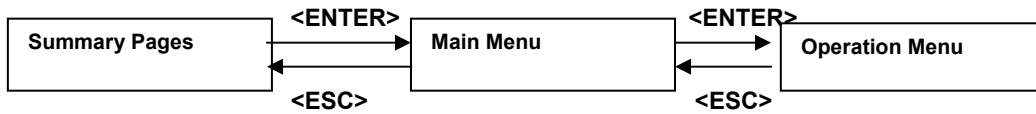

OPERATION MENU	
Status	: ON
Mode	: Cooling
Cool Temp	: 12.0°C
Heat Temp	: 40.0°C

In [Operation Menu], select “Cool Temp” / “Heat Temp” and press **ENTER** to start setting or **ESC** to exit to [Main Menu].

OPERATION MENU	
Status	: ON
Mode	: Cooling
Cool Temp	: 12.0°C
Heat Temp	: 40.0°C

Change value via **UP** or **DOWN** button, and then press **ENTER** to confirm the change or **ESC** to cancel.

ii) [Set Parameter]

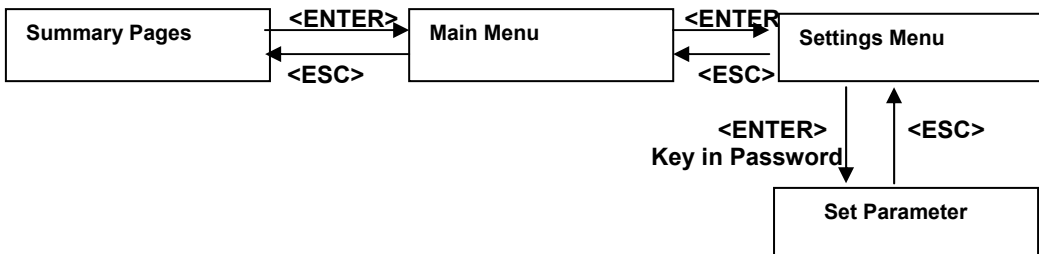

1. General
2. Sensor
3. Regulator
4. Compressor
5. Defrost
6. Antifreeze
7. Alarm and Contact

In [Set Parameter], select “Regulator” and press **ENTER**. Press **ESC** to exit to [Main Menu].

R1 Cool SP	: 12.0°C
R2 Cool Diff	: 3.0°C
R3 Heat SP	: 40.0°C
R4 Heat Diff	: 3.0°C
R5 Min Cool SP	: -20°C
R6 Max Cool SP	: 40°C
R7 Min Heat SP	: -20°C

Select “R3” / “R5” and press **ENTER** to start setting or **ESC** to exit to [Set Parameter] menu.

R1 Cool SP	: 12.0°C
R2 Cool Diff	: 3.0°C
R3 Heat SP	: 40.0°C
R4 Heat Diff	: 3.0°C
R5 Min Cool SP	: -20°C
R6 Max Cool SP	: 40°C
R7 Min Heat SP	: -20°C

Change value via **UP** or **DOWN** button. The borderlines limited by **R5&R6** (cool), **R7&R8** (heat). Press **ENTER** to confirm or **ESC** to cancel.

6.2.6 Manual Defrost

User can choose which compressor will go into manual defrost cycle by using the Chiller Panel, as long as the condition is fulfilled with defrost condition. This can be done in **[Operation Menu]**.

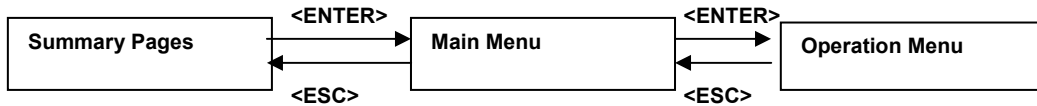

Please take note that **“Manual Defrost”** option will only available in HEATING mode. It will disappear in COOLING/BOILING mode.

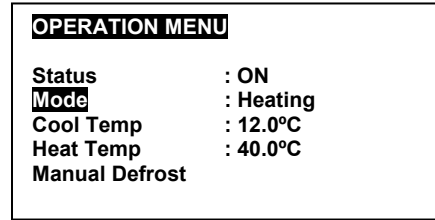
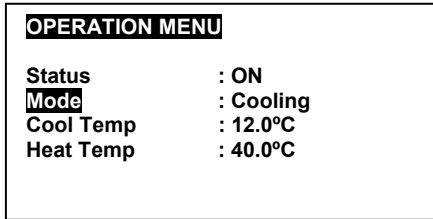

“Manual Defrost” disappear when Chiller not in HEATING mode

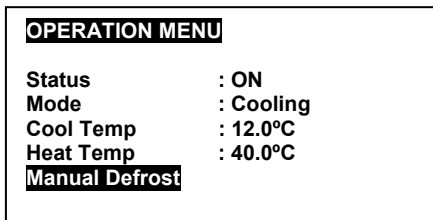

*In **[Operation Menu]**, select **[Manual Defrost]**, press **ENTER** to go into it, or **ESC** to exit to **[Main Menu]**.*

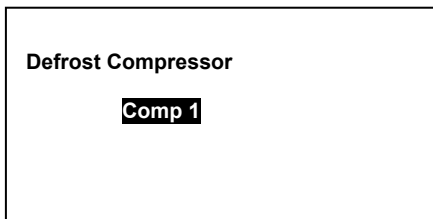

*Select which compressor to go into defrost cycle via **UP** or **DOWN** button. Press **ENTER** to confirm or **ESC** to exit to **[Operation Menu]**.*

6.2.7 Advance Parameter Settings

The Chiller Panel provide user a lot of advance parameter settings for the Chiller. The parameters are divided into 7 groups. There all are stored in **[Set Parameter]** menu and it is password-protected layer in the panel.

***CAUTION: INPROPER SETTINGS WILL CAUSE PERMANENT DAMAGE TO THE CHILLER!!!**

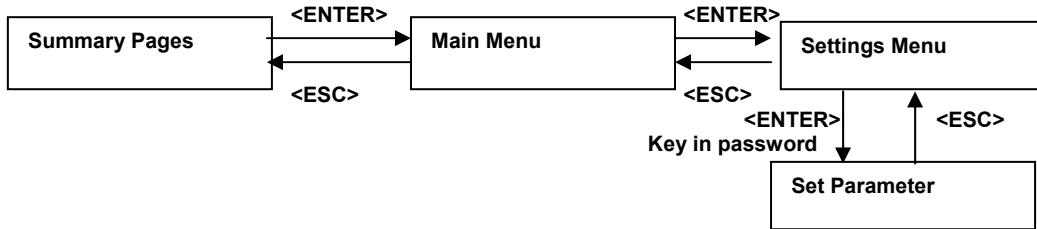

7 groups of Advance Parameter:

1) General

G1 Model	: Chiller
G2 No.Comp	: 1 Comp
G3 On/Off In	: Disabale
G4 Co/ Heat In	: Disable
G5 Ext Alarm in	: Disable
G6 Water Sys	: Isolated
G7 Unit No	: 0

2) Sensor

S1 Water Enter	: 0.0°C
S2 Water Leave	: 0.0°C
S3 Air Sensor	: 0.0°C
S4 Defrost 1	: 0.0°C
S5 Defrost 2	: 0.0°C
S6 Defrost 3	: 0.0°C
S7 Defrost 4	: 0.0°C

S8 Cp Dish 1	: 0.0°C
S9 Cp Dish 2	: 0.0°C
S10 Cp Dish 3	: 0.0°C
S11 Cp Dish 4	: 0.0°C

3) Regulator

R1 Cool SP	: 12.0°C
R2 Cool Diff	: 3.0°C
R3 Heat SP	: 40.0°C
R4 Heat Diff	: 3.0°C
R5 Mix Cool SP	: -20°C
R6 Max Cool SP	: 40°C
R7 Min Heat SP	: -20°C

R8 Max Heat SP	: 90°C
R9 Ax Heat SP	: 5.0°C
R10 Ax Heat Diff	: 2.0°C
R11 Au Bo SP	: 5.0°C
R12 Au Bo Diff	: 2.0°C
R13 Au Bo Start	: 30m

4) Compressor

C1 Min Run	: 120s
C2 Min Stop	: 240s
C3 2On Interval	: 360s
C4 2Cp ON Dly	: 15s
C5 P-Cp ON Dly	: 60s
C6 Cp-P OFF Dly	: 60s
C7 Cp Cut Off	: 120°C

5) Condenser Defrost

D1 Start Temp	: -3°C
D2 End Temp	: 14°C
D3 Max Dura	: 10m
D4 Interval	: 45m
D5 Dly Bfr Def	: 0s
D6 Dly Aft Def	: 0s

6) Cool Mode Antifreeze

A1 Heater SP	: 5°C
A2 Heater Diff	: 2.0°C
A3 Sensor	: Leave
A4 Alarm SP	: 3°C
A5 Alarm Diff	: 2.0°C

7) Alarm and Contact

P1 FS Confirm	: 5s
P2 FS Delay	: 180s
P3 LP Delay	: 30s
P4 CO Reset	: Manual
P5 HP Rest	: Auto
P6 LP Reset	: Auto
P7 FO Reset	: Manual

P8 RO Reset	: Manual
P9 FS Reset	: Manual
P10 Aux Reset	: Manual
P11 A/F Reset	: Manual
P12 CO Contact	: Normal
P13 HP Contact	: Normal
P14 LP Contact	: Normal

P15 FO Contact	: Normal
P16 PO Contact	: Normal
P17 FS Contact	: Normal
P18 EA Contact	: Normal
P19 DE Contact	: Normal

Please refer to **8. APPENDIX** for detail description.

6.2.8 Changing Password

For security purpose, some places in the panel are password-protected. User can change the password at anytime.

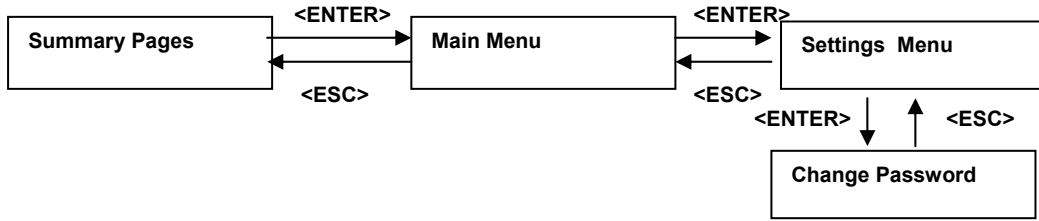

Please enter the
Old password.....

0

User needs to enter the old password in order to change the password.
Change the 1st digit value via **UP** or **DOWN**. Press **ENTER** to start enter 2nd digit and the rest, or **ESC** to exit at anytime.

Password accepted

Access granted !

Password error

Access denied !

If password correct, this message will be shown and proceed to new password settings.

If password not correct, this message will be shown and exit to **[Settings Menu]**

Please enter the
New password.....

0

Same as previous, **UP DOWN** to change value, **ENTER** to go to next digit, **ESC** to exit.
User is not allowed to set the password to 0000.

New password
has been set.....

New password
'0 0 0 0'
Is not accepted

If new password is accepted, this message will be shown and then exit to **[Settings Menu]**.

If new password is '0000', this message will be shown and then exit to **[Settings Menu]**. The password remains as previous.

6.2.9 Clock Setting

User can set the clock for the panel.

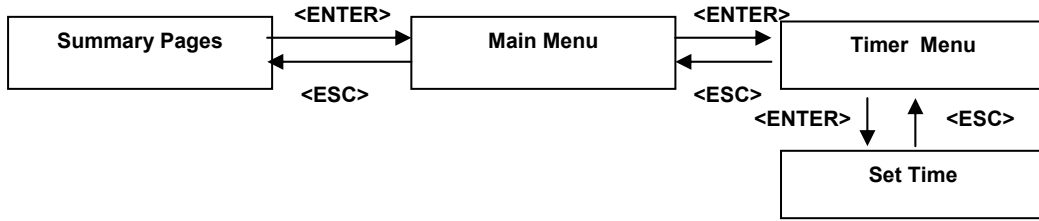

Set Time :

hh mm

:

UP or **DOWN** to change 'hour'. **ENTER** to set 'minute' or **ESC** to exit to [Timer Menu].

UP or **DOWN** to change 'minute'. **ENTER** to confirm or **ESC** to set 'hour' again.

6.4.10 Date Setting

User can set the date for the panel.

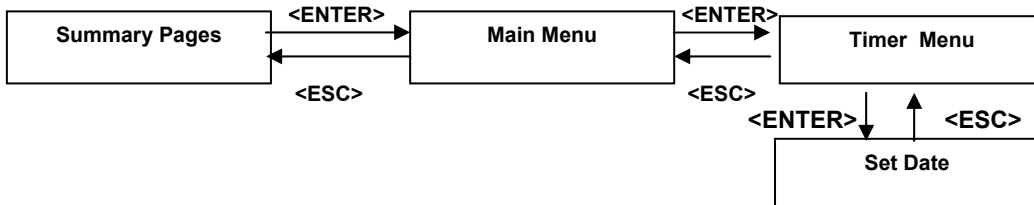

Set Date :

yyyy mm dd

/ /

UP or **DOWN** to change 'year'. **ENTER** to set 'month' or **ESC** to exit to [Timer Menu].

UP or **DOWN** to change 'month'. **ENTER** to set 'day' or **ESC** to set 'year' again.

UP or **DOWN** to change 'day'. **ENTER** to confirm or **ESC** to set 'month' again.

6.2.11 7 Days Programmable Setting

There are 2 ON/OFF events in one day for the schedule. This schedule is applicable to all the chillers in the network.

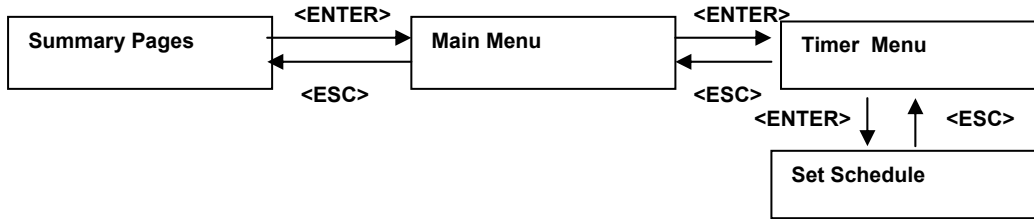

```

Timer 1   Timer 2
ON OFF ON OFF

Sun 0800 1800 - - - - -
Mon 0800 1800 - - - - -
Tue 0800 1800 - - - - -
Wed 0800 1800 - - - - -
  
```

UP or DOWN select day of week. ENTER to select event or ESC to exit to [Timer Menu].

```

Timer 1   Timer 2
ON OFF ON OFF

Sun 0800 1800 - - - - -
Mon 0800 1800 - - - - -
Tue 0800 1800 - - - - -
Wed 0800 1800 - - - - -
  
```

UP or DOWN select event. ENTER to start setting or ESC to back to select day of week.

Event setting is same like time setting. User can disable the event by set it to '- - -'

Before the schedule will carry the effect, user need to set **ENABLE** for “**TIMER**” in [Timer Menu].

```

TIMER MENU

Set Time
Set Date
Set Schedule
Timer : Disable
  
```

Select “Timer” and press ENTER to start the settings. UP or DOWN to toggle Enable/Disable, ENTER to confirm or ESC to cancel.

6.2.12 Viewing Alarm / Erase Alarm Record

Whenever a new fault/alarm is occurred, there will be a message pop up to show the fault/alarm. Backlight will be blinking with beeping sound (if “**Alarm Buzzer**” is set ON). If the fault/alarm has not been dissolved from the Chiller, a sign **[A]** will be shown in the **[Summary Pages]**. Whereas, it will return to **[Summary Pages]** (from pop up menu) automatically if the fault/alarms have been dissolved.

While the fault/alarms have not been dissolved (sign **[A]**), user can check that fault/alarm by go into **[Alarm Menu]**. If all the fault/alarm have been dissolved, user can view the fault/alarm history records in **[Alarm Menu]** as well. Screen saver will be deactivated while all the alarms have not been dissolved.

If panel ID is set 0 (Master panel), it can receive and view all the fault/alarms from all chillers in the network.

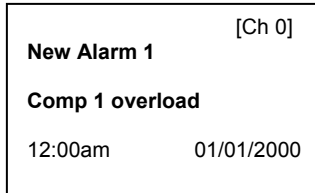

*[Ch 0] show alarm occurred unit.
Press any button to stop backlight blinking and beeping.
Press **ESC** again to exit to normal page.*

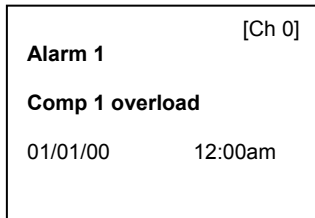
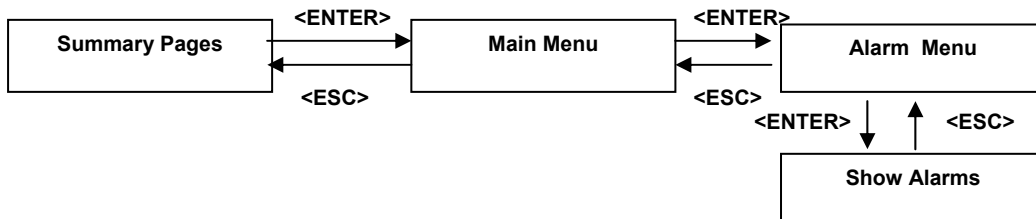

*Press **UP** or **DOWN** to scroll the record.
Press **ENTER** if user want to erase the record, or **ESC** to exit to **[Alarm Menu]**.*

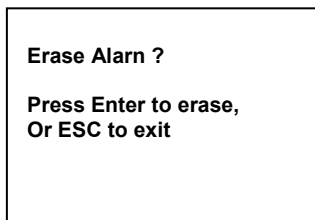

Press **ENTER** to erase the alarm, or **ESC** to cancel.

User can erase all the fault / alarm record at once time through **[Erase All Alarms]** in **[Alarm Menu]**.

6.2.13 Viewing Defrost Sensor Temperature

The Chiller Panel displays defrost sensor temperature for each compressor in **[Defrost Sensor]** in **[Display Menu]**.

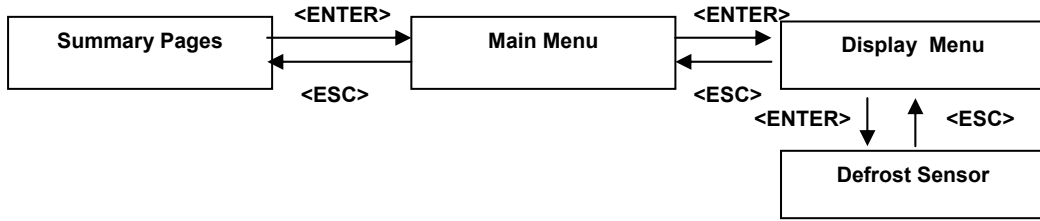

Defrost Sensor
Comp 1 : 12.8°C

Press **ESC** to exit to **[Display Menu]**

6.2.14 Viewing Compressor Discharge Temperature

The Chiller Panel displays compressor discharge temperature for each compressor in **[Discharge Sensor]** in **[Display Menu]**.

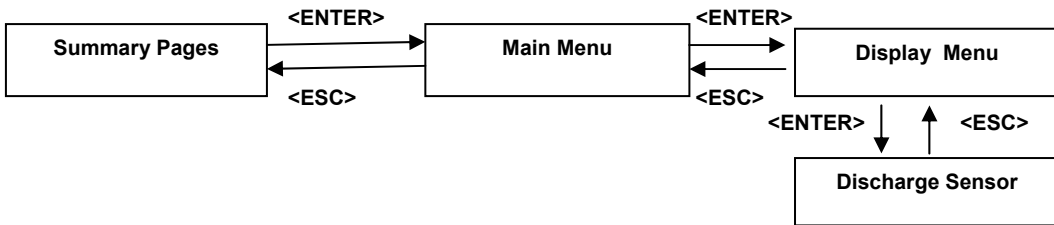

Discharge Sensor
Comp1 36.5°C

Press **ESC** to exit to **[Display Menu]**

6.2.15 Viewing/Clear Compressor Run Time

User can view / clear the compressor run time for the Chiller in [Comp Run Time] in [Display Menu].

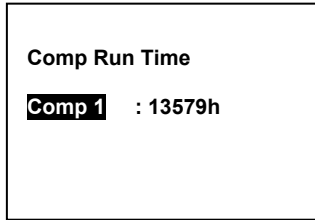
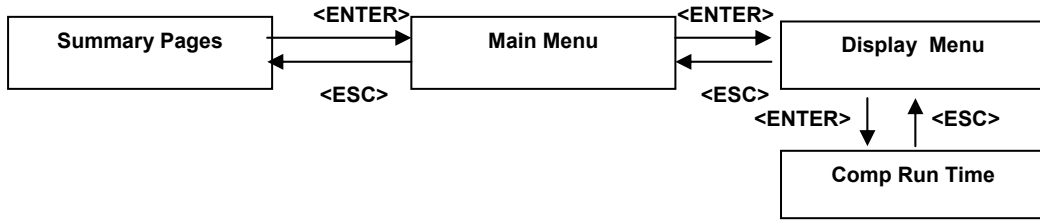

Press **UP** or **DOWN** to select the compressor. **ENTER** to start clear the run time, or **ESC** to exit to [Display Menu].

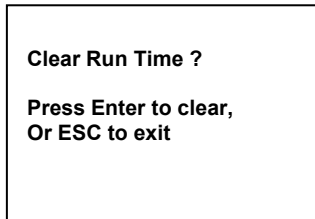

Press **ENTER** and key in the password to confirm or **ESC** to cancel.

6.2.16 Miscellaneous Settings

User can do some miscellaneous settings to the panel.

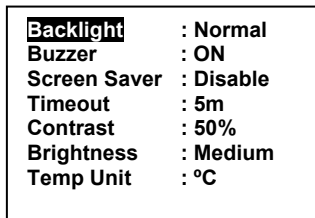
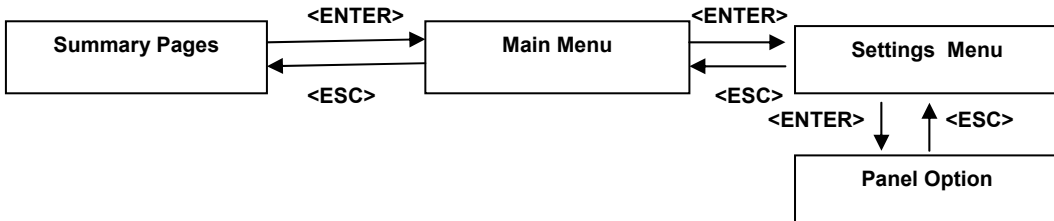

Press **UP** or **DOWN** to select the item. **ENTER** to set, or **ESC** to exit to [Settings Menu].

Press **UP** or **DOWN** to toggle the value. **ENTER** to confirm, or **ESC** to cancel

Parameter	Value	Description
Backlight	Normal	Turn ON backlight for 30s via key press
	Always	Always ON backlight
Buzzer	ON	Enable beeping sound when fault/ alarm occurred
	OFF	Disable beeping sound when fault / alarm occurred
* Screen Saver	Enable	Show screen saver when timeout
	Disable	No screen save
* Timeout	1 – 30m	Timeout for showing screen saver
Contract	0 – 100%	Adjust the contrast setting for the LCD panel
Brightness	OFF	No backlight
	Low, Medium, High	Adjust the backlight intensity
Temp Unit	°C	Display temperature in degree Celsius
	°F	Display temperature in Fahrenheit

* This product must be branded. Screen saver will be deactivated for brand less panel

6.3 CMOS Reset

- CMOS reset allows user to reset some settings to default value such as:

Password -> 0001
 Backlight -> Normal
 Buzzer -> ON
 Screen Saver -> Disable
 Timeout -> 5m
 Contrast -> 50%
 Brightness -> Medium
 Temp Unit -> °C

- Procedures

1. Power OFF the panel
2. Close the jumper JH2 with the provided jumper header
3. Power ON the panel and the LCD panel should display as follow:

CMOS is resetting

CMOS reset completed!

**Please remove JUMPER
and restart the panel**

4. Remove the jumper header (put the jumper header on 1 pin only), power OFF and then power ON the panel.

7. PROBLEMS AND TROUBLESHOOTING

	Symptoms	Possible Cause	Troubleshooting
1	Panel gets hot abnormally	<ul style="list-style-type: none"> Wiring fault in 12VDC supply 	<ul style="list-style-type: none"> Change a new panel module and turn ON the unit again after the verification
2	The LCD no display (blank screen)	<ul style="list-style-type: none"> Wiring fault in the 12VDC supply 	<ul style="list-style-type: none"> Correct the wiring problem
		<ul style="list-style-type: none"> No power supply 	<ul style="list-style-type: none"> Check the wiring and supply 12VDC to panel
		<ul style="list-style-type: none"> Voltage supply too low 	<ul style="list-style-type: none"> Check the power source
		<ul style="list-style-type: none"> Module defective 	<ul style="list-style-type: none"> Change a new panel module
3	'- -' for all status (quite a long time)	<ul style="list-style-type: none"> Panel cannot/not yet received the information from Chiller or FCU completely 	<ul style="list-style-type: none"> Ensure the selected unit exists in the network. Ensure the wiring is correct. Ensure the wiring is not defective. Ensure the wiring has been isolated from high power cable
		<ul style="list-style-type: none"> That particular unit address is not recognized by the panel 	<ul style="list-style-type: none"> Select a coherent unit address on the panel (refer to 6.2.2)
		<ul style="list-style-type: none"> Module defective 	<ul style="list-style-type: none"> Change a new module
4	ON/OFF, COOL or HEAT button not function	<ul style="list-style-type: none"> Software limitation 	<ul style="list-style-type: none"> Ensure it is pressed (hold 1s) in [Summary Pages], not in others menu.
		<ul style="list-style-type: none"> Module defective 	<ul style="list-style-type: none"> Change a new module
5	Cannot switch to HEATING mode	<ul style="list-style-type: none"> Software limitation 	<ul style="list-style-type: none"> Ensure this mode is available in current "Model" of Chiller. Please refer to 6.2.4
6	Cannot switch to BOILING mode	<ul style="list-style-type: none"> Software limitation 	<ul style="list-style-type: none"> Ensure this mode is available in current "Model" of Chiller. Please refer to 6.2.4
7	No "Manual Defrost" item	<ul style="list-style-type: none"> Software limitation 	<ul style="list-style-type: none"> Ensure current running mode is HEATING
8	Cannot step inside [Set Parameter]	<ul style="list-style-type: none"> Software limitation. Panel has not received all the information from Chiller completely 	<ul style="list-style-type: none"> Refer to <i>symptoms 3</i>
9	7 Days Programmable Timer not function	<ul style="list-style-type: none"> Software limitation. User did not activate the schedule 	Control of Chiller: <ul style="list-style-type: none"> Ensure the "Timer" in [Timer Menu] is set ENABLE Control of Chiller: <ul style="list-style-type: none"> Ensure the "Timer" in [Operation Menu] is set ENABLE
10	No beeping sound when new alarm occurred	<ul style="list-style-type: none"> Software limitation. User did not set ON to the alarm buzzer 	<ul style="list-style-type: none"> Ensure "Buzzer" in [Panel Option] is set ON
11	No screen saver after timeout	<ul style="list-style-type: none"> Software limitation. User did not set ENABLE to the screen saver 	<ul style="list-style-type: none"> Ensure "Screen Saver" in [Panel Option] is set ENABLE
12	Time always reset to 12:00am, 1 st Jan 2000	<ul style="list-style-type: none"> No backup battery Energy of the backup battery is low 	<ul style="list-style-type: none"> Replace a coin cell battery
13	Panel stop operation. Whole operation freezing (hang)	<ul style="list-style-type: none"> Unstable power supply Energy of the backup battery is low 	<ul style="list-style-type: none"> Power off the panel. Take out the backup battery as well. Replace with a new 3V coin cell battery if necessary. Put back the backup battery into the panel and power on again.

8. APPENDIX

	GENERAL	Type	Unit	Default	Min	Max	Resolution
G1	Model 0=Chiller, 1=Heat Pump, 2=Chiller/ Boiler, 3=Heat pump/Boiler, 4=Chiller+Boiler, 5=Heat pump+Boiler	F	Flag	4 (Chiller+Boiler)	0	2	1
G2	Number of compressor 1=1 compressor, 2=2 compressor, 3=3 compressor, 4=4 compressor	F	Flag	1	1	4	1
G3	On/off input 0=disable, 1=enable	F	Flag	0 (disable)	0	1	1
G4	Cool/Heat input 0=disable, 1=enable	F	Flag	0 (disable)	0	1	1
G5	External alarm input 0=disable, 1=enable	F	Flag	0 (disable)	0	1	1
G6	Water system for chiller network 0=independent, 1=modular	F	Flag	0 (disable)	0	1	1
G7	Unit number	F	Flag	0	0	50	1

	SENSOR	Type	Unit	Default	Min	Max	Resolution
S1	Entering water sensor calibration	U	°C (F)	0 (0)	-12 (21.6)	12 (21.6)	0.1
S2	Leaving water sensor calibration	U	°C (°F)	0 (0)	-12 (-21.6)	12 (21.6)	0.1
S3	Air sensor calibration	U	°C (°F)	0 (0)	-12 (-21.6)	12 (21.6)	0.1
S4	Defrost (condenser) sensor 1 calibration	U	°C (°F)	0 (0)	-12 (-21.6)	12 (21.6)	0.1
S5	Defrost (condenser) sensor 2 calibration	U	°C (°F)	0 (0)	-12 (-21.6)	12 (21.6)	0.1
S6	Defrost (condenser) sensor 3 calibration	U	°C (°F)	0 (0)	-12 (-21.6)	12 (21.6)	0.1
S7	Defrost (condenser) sensor 4 calibration	U	°C (°F)	0 (0)	-12 (-21.6)	12 (21.6)	0.1
S8	Compressor discharge sensor 1 calibration	U	°C (°F)	0 (0)	-12 (-21.6)	12 (21.6)	0.1
S9	Compressor discharge sensor 2 calibration	U	°C (°F)	0 (0)	-12 (-21.6)	12 (21.6)	0.1
S10	Compressor discharge sensor 3 calibration	U	°C (°F)	0 (0)	-12 (-21.6)	12 (21.6)	0.1
S11	Compressor discharge sensor 4 calibration	U	°C (°F)	0 (0)	-12 (-21.6)	12 (21.6)	0.1

	REGULATOR	Type	Unit	Default	Min	Max	Resolution
R1	Cooling set-point	D	°C (°F)	12 (53.6)	R5	R6	0.1
R2	Cooling differential	U	°C (°F)	1.5* (2.7)	0.4 (0.7)	10(18)	0.1
R3	Heating set-point	D	°C (°F)	40 (104)	R7	R8	0.1
R4	Heating differential	U	°C (°F)	1.5* (2.7)	0.4 (0.7)	10 (18)	0.1
R5	Minimum Cooling set-point	U	°C (°F)	7 (44.6)	-20 (-4)	R6	1
R6	Maximum Cooling set-point	U	°C (°F)	20 (68)	R5	40 (104)	1
R7	Minimum Heating set-point	U	°C (°F)	30 (86)	-20 (-4)	R8	1
R8	Maximum Heating set-point	U	°C (°F)	50 (122)	R7	90 (194)	1
R9	Auxiliary heater set-point (threshold below heating set-point)	U	°C (°F)	5 (9)	0 (0)	40 (72)	0.1
R10	Auxiliary heater differential	U	°C (°F)	2 (3.6)	0.4 (0.7)	10 (18)	0.1
R11	Auto boiler set-point (threshold below heating set-point)	U	°C (°F)	5 (9)	0 (0)	40 (72)	0.1
R12	Auto boiler differential	U	°C (°F)	2(3.6)	0.4 (0.7)	10(18)	0.1
R13	Auto boiler start time threshold	U	min	30	0	199	1

	COMPRESSOR	Type	Unit	Default	Max	Min	Resolution
C1	Compressor minimum run time	U	sec	120	0	1990	10
C2	Compressor minimum stop time	U	sec	180	0	1990	10
C3	Time interval between two starts	U	sec	450	0	1990	10
C4	Start delay between two compressors	U	sec	15	0	199	1
C5	Pump on → compressor on delay	U	sec	180	0	1990	10
C6	Comp off → pump off delay	U	sec	60	0	199	10
C7	Discharge cut-off set-point	U	°C	120 (248)	0 (32)	150 (302)	1

	CONDENSER DEFROST	Type	Unit	Default	Max	Min	Resolution
D1	Start defrost temperature	U	°C (°F)	0(32)	-20(-4)	D2	1
D2	End defrost temperature	U	°C (°F)	14 (57)	D1	40 (104)	1

D3	Maximum duration of defrost cycle	U	min	10	1	40	1
D4	Defrost interval time	U	min	45	0	199	1
D5	Delay before defrosting	U	sec	0	0	1990	10
D6	Delay after defrosting	U	sec	120	0	1990	10

	COOL MODE ANTIFREEZE	Type	Unit	Default	Min	Max	Resolution
A1	Antifreeze heater set-point	U	°C (F)	5 (41)	-40 (-40)	40 (104)	1
A2	Antifreeze heater differential	U	°C (°F)	2 (3.6)	0.4 (0.7)	10 (18)	0.1
A3	Antifreeze sensor select 0=Leaving water, 1=Entering water	U	Flag	0 (leaving)	0	1	1
A4	Antifreeze alarm set-point	U	°C (°F)	3 (37)	-40 (-40)	40 (104)	1
A5	Antifreeze alarm differential	U	°C (°F)	2 (3.6)	0.4 (0.7)	10 (18)	0.1

	ALARM AND CONTACT	Type	Unit	Default	Min	Max	Resolution
P1	Flow switch confirmation time	U	sec	5	0	199	1
P2	Flow switch alarm delay at pump start	U	sec	120	0	199	1
P3	Low pressure alarm delay at compressor start-up	U	sec	30	0	199	1
P4	Comp overload alarm reset type 0=Manual reset, 1=Auto reset	U	Flag	0 (manual)	0	1	1
P5	High pressure alarm reset type 0=Manual reset, 1=Auto reset	U	Flag	1 (auto)	0	1	1
P6	Low pressure alarm reset type 0=Manual reset, 1=Auto reset	U	Flag	1 (auto)	0	1	1
P7	Fan overload alarm reset type 0=Manual reset, 1=Auto reset	U	Flag	1 (auto)	0	1	1
P8	Pump overload alarm reset type 0=Manual reset, 1=Auto reset	U	Flag	0 (manual)	0	1	1
P9	Flow switch alarm reset type 0=Manual reset, 1=Auto reset	U	Flag	0 (manual)	0	1	1
P10	Auxiliary alarm reset type 0=Manual reset, 1=Auto reset	U	Flag	1 (auto)	0	1	1
P11	Antifreeze alarm reset type 0=Manual reset, 1=Auto reset	U	Flag	1 (auto)	0	1	1
P12	Comp overload contact type 0=Normally close (NC) 1=Normally open (NO)	U	Flag	0 (NC)	0	1	1
P13	High pressure contact type 0=Normally close (NC) 1=Normally open (NO)	U	Flag	0 (NC)	0	1	1
P14	Low pressure contact type 0=Normally close (NC) 1=Normally open (NO)	U	Flag	0 (NC)	0	1	1
P15	Fan overload contact type 0=Normally close (NC) 1=Normally open (NO)	U	Flag	0 (NC)	0	1	1
P16	Pump overload contact type 0=Normally close (NC) 1=Normally open (NO)	U	Flag	0 (NC)	0	1	1
P17	Flow switch contact type 0=Normally close (NC) 1=Normally open (NO)	U	Flag	0 (NC)	0	1	1
P18	External alarm contact type 0=Normally close (NC) 1=Normally open (NO)	U	Flag	0 (NC)	0	1	1
P19	Defrost end contact type 0=Normally close (NC) 1=Normally open (NO)	U	Flag	0 (NC)	0	1	1

Specifications

Air Cooled Chiller – R22 Cooling Only

MODEL			MAC080C	MAC100C	MAC120C	MAC150C	
NOMINAL CAPACITY			Btu/hr	78000	93000	116000	138000
			kcal/hr	19657	23437	29233	34777
			Watt	22860	27257	33998	40445
CASING	MATERIAL		Electro-galvanized Mild Steel				
	FINISH		Polyester Powder				
	THICKNESS		1.5				
DIMENSION	HEIGHT (H)	mm	1245		1245		
	WIDTH (W)	mm	1500		1800		
	DEPTH (D)	mm	900		1150		
WEIGHT			kg	340	350	460	540
NOISE LEVEL			dBA	65	66	67	69
PACKING DIMENSION	HEIGHT (H)	mm	1452		1452		
	WIDTH (W)	mm	1732		2032		
	DEPTH (D)	mm	1032		1282		
CONDENSER COIL							
TYPE			Cross Finned Tubes				
TUBE	MATERIAL		Seamless Copper				
	WALL THICKNESS	mm	0.35				
	OUTER DIAMETER	mm	9.52				
FIN	MATERIAL		Aluminium (Hydrophilic)				
	THICKNESS	mm	0.11				
	ROWS		2	2	2	2	
	FIN PER INCH		14	14	14	14	
TOTAL FACE AREA			m ²	1.37	1.37	1.79	1.79
EVAPORATOR							
TYPE			Brazen Plate Heat Exchanger				
PLATE MATERIAL			Stainless Steel				
NOMINAL WATER FLOW			L/s	1.08	1.31	1.67	2.00
CONDENSER FAN							
TYPE/DRIVE			Propeller/Direct				
QUANTITY			2		2		
BLADE MATERIAL			Aluminium				
BLADE DIAMETER			INCH	24	26		
POWER SUPPLY			V/Ph/Hz	220-240/1/50			
RATED RUNNING CURRENT			Amp	1.2 x 2	1.2 x 2	1.8 x 2	3.4 x 2
RATED INPUT			Watt	283 x 2		386 x 2	766 x 2
RATED OUTPUT			Watt	120 x 2		200 x 2	450 x 2
MOTOR POLES				8	8	8	6
WATER LINE (HYDRAULIC KIT)							
PUMP	TYPE		Horizontal Multistage End-Suction				
	MAX. WATER OPER. PRESSURE	kPa	1000				
	RUNNING CURRENT	Amp	1.5	1.5	2.0	2.0	
	WATER FLOW RATE	GPM	17.2	20.7	26.4	31.7	
PIPING	INSTALLATION PIPE CONNECTION	mm(in)	42mmBSP(1 ¹ / ₄ "				
	HEAD	m	26	23.5	25	23	
COMPRESSOR							
TYPE			SCROLL				
POWER SUPPLY			V/Ph/Hz	380-415/3/50			
RATED CURRENT			Amp x 2	7.0	7.4	9.9	11.2
RATED INPUT			Watt x 2	3526	4280	4717	5724
MAXIMUM STARTING CURRENT			Amp	65 x 2	74 x 2	76 x 2	95 x 2
PROTECTION DEVICES			Overload Protection, Differential and H/L Pressure Switch				
STAGE OF CAPACITY CONTROL			0~50~100				
REFRIGERANT							
TYPE			R22				
CONTROL			TXV				
CHARGING MASS			kg	4.5 x 2	3.9 x 2	6.0 x 2	7.1 x 2

Note : Nominal values are based on 12°C / 7°C entering / leaving evaporator water temperature , 35°C air ambient temperature.

Air Cooled Chiller – R22 Heat Pump

MODEL		MAC080CR	MAC100CR	MAC120CR	MAC150CR	
NOMINAL CAPACITY (COOLING / HEATING)		Btu/hr	77000 / 90000	94000 / 110000	113000 / 120000	138000 / 132000
		kcal/hr	19405 / 22680	23689 / 27721	28477 / 30241	34778 / 33266
		Watt	22567 / 26376	27549 / 32239	33118 / 35169	40445 / 38686
CASING	MATERIAL	Electro-galvanized Mild Steel				
	FINISH	Polyester Powder				
	THICKNESS	mm	1.5			
DIMENSION	HEIGHT (H)	mm	1245		1245	
	WIDTH (W)	mm	1500		1800	
	DEPTH (D)	mm	900		1150	
WEIGHT	kg	350	360	480	560	
NOISE LEVEL	dBA	61	62	63	64	
PACKING DIMENSION	HEIGHT (H)	mm	1452		1452	
	WIDTH (W)	mm	1732		2032	
	DEPTH (D)	mm	1032		1282	
CONDENSER COIL						
TYPE		Cross Finned Tubes				
TUBE	MATERIAL	Seamless Copper				
	WALL THICKNESS	mm	0.35			
	OUTER DIAMETER	mm	9.52			
FIN	MATERIAL	Aluminium (Hydrophilic)				
	THICKNESS	mm	0.11			
	ROWS		2	2	2	2
	FIN PER INCH		14	14	14	14
TOTAL FACE AREA	m ²	1.37	1.37	1.79	1.79	
EVAPORATOR						
TYPE		Braze Plate Heat Exchanger				
PLATE MATERIAL		Stainless Steel				
NOMINAL WATER FLOW	L/s	1.08 / 1.14	1.31 / 1.37	1.67 / 1.79	2.00 / 2.10	
CONDENSER FAN						
TYPE/DRIVE		Propeller/Direct				
QUANTITY		2		2		
BLADE MATERIAL		Aluminium				
BLADE DIAMETER	INCH	24		26		
POWER SUPPLY	V/Ph/Hz	220-240/1/50				
RATED RUNNING CURRENT	Amp	1.2 x 2	1.2 x 2	1.8 x 2	3.4 x 2	
RATED INPUT(COOLING / HEATING)	Watt	283 x 2		386 x 2	766 x 2	
RATED OUTPUT(COOLING / HEATING)	Watt	120 x 2		200 x 2	450 x 2	
MOTOR POLES		8	8	8	6	
WATER LINE (HYDRAULIC KIT)						
PUMP	TYPE	Horizontal Multistage End-Suction				
	MAX WATER OPER. PRESSURE	kPa	1000			
	RUNNING CURRENT	Amp	1.5	1.5	2.0	2.0
	WATER FLOW RATE	GPM	17.2 / 18.1	20.7 / 21.7	26.4 / 28.4	31.7 / 33.3
PIPING	INSTALLATION PIPE CONNECTION	mm(in)	42mmBSP(1 ¹ / ₄ "			
	HEAD	m	26 / 25	23.5 / 22.5	25 / 24.5	23 / 22.5
COMPRESSOR						
TYPE		SCROLL				
POWER SUPPLY	V/Ph/Hz	380-415/3/50				
RATED CURRENT (COOLING / HEATING)	Amp x 2	7.0 / 6.7	8.0 / 7.6	10.2 / 10.3	11.0 / 11.5	
RATED INPUT (COOLING / HEATING)	Watt x 2	3981 / 3857	4595 / 4347	5071 / 5188	5775 / 6120	
MAXIMUM STARTING CURRENT	Amp	65 x 2	74 x 2	76 x 2	95 x 2	
PROTECTION DEVICES		Overload Protection, Differential and H/L Pressure Switch				
STAGE OF CAPACITY CONTROL		ON/OFF				
REFRIGERANT						
TYPE		R22				
CONTROL		Capillary Tube				
CHARGING MASS	kg	4.3 x 2	4.5 x 2	7.6 x 2	6.5 x 2	

Note : Nominal values are based on 12°C / 7°C entering / leaving evaporator water temperature , 35°C air ambient temperature.

Note : Nominal values are based on 40°C / 45°C entering / leaving evaporator water temperature , 7°C air ambient temperature.

Note : Unit dimension without hydraulic kit.

Air Cooled Chiller – R407 Cooling Only

MODEL		M4AC080C	M4AC100C	M4AC120C	M4AC150C	
NOMINAL CAPACITY	Btu/hr	74000	88000	115000	137000	
	kcal/hr	18649	22177	28982	34525	
	Watt	21688	25791	33705	40152	
CASING	MATERIAL	Electro-galvanized Mild Steel				
	FINISH	Polyester Powder				
	THICKNESS	mm	1.5			
DIMENSION	HEIGHT (H)	mm	1245	1245		
	WIDTH (W)	mm	1500	1800		
	DEPTH (D)	mm	900	1150		
WEIGHT	kg	340	350	460	540	
NOISE LEVEL	dBA	65	66	67	69	
PACKING DIMENSION	HEIGHT (H)	mm	1452	1452		
	WIDTH (W)	mm	1732	2032		
	DEPTH (D)	mm	1032	1282		
CONDENSER COIL						
TYPE		Cross Finned Tubes				
TUBE	MATERIAL	Seamless Copper				
	WALL THICKNESS	mm	0.35			
	OUTER DIAMETER	mm	9.52			
FIN	MATERIAL	Aluminium (Hydrophilic)				
	THICKNESS	mm	0.11			
	ROWS		2	2	2	2
	FIN PER INCH		14	14	14	14
TOTAL FACE AREA	m ²	1.37	1.37	1.79	1.79	
EVAPORATOR						
TYPE		Braze Plate Heat Exchanger				
PLATE MATERIAL		Stainless Steel				
NOMINAL WATER FLOW	L/s	1.08	1.31	1.67	2.00	
CONDENSER FAN						
TYPE/DRIVE		Propeller/Direct				
QUANTITY		2		2		
BLADE MATERIAL		Aluminium				
BLADE DIAMETER	INCH	24		26		
POWER SUPPLY	V/Ph/Hz	220-240/1/50				
RATED RUNNING CURRENT	Amp	1.2 x 2	1.2 x 2	1.8 x 2	3.4 x 2	
RATED INPUT	Watt	283 x 2		386 x 2	766 x 2	
RATED OUTPUT	Watt	120 x 2		200 x 2	450 x 2	
MOTOR POLES		8	8	8	6	
WATER LINE (HYDRAULIC KIT)						
PUMP	TYPE	Horizontal Multistage End-Suction				
	MAX. WATER OPER. PRESSURE	kPa	1000			
	RUNNING CURRENT	Amp	1.5	1.5	2.0	2.0
	WATER FLOW RATE	GPM	17.2	20.7	26.4	31.7
PIPING	INSTALLATION PIPE CONNECTION	mm(in)	42mmBSP(1 ¹ / ₄ "			
	HEAD	m	26	23.5	25	23
COMPRESSOR						
TYPE		SCROLL				
POWER SUPPLY	V/Ph/Hz	380-415/3/50				
RATED CURRENT	Amp x 2	7.5	7.9	10.2	11.8	
RATED INPUT	Watt x 2	3924	4578	5117	6100	
MAXIMUM STARTING CURRENT	Amp	65 x 2	74 x 2	76 x 2	95 x 2	
PROTECTION DEVICES		Overload Protection, Differential and H/L Pressure Switch				
STAGE OF CAPACITY CONTROL		0~50~100				
REFRIGERANT						
TYPE		R407C				
CONTROL		TXV				
CHARGING MASS	kg	4.0 x 2	3.9 x 2	5.6 x 2	6.0 x 2	

Note : Nominal values are based on 12°C / 7°C entering / leaving evaporator water temperature , 35°C air ambient temperature.

Air Cooled Chiller – R407 Heat Pump

MODEL		M4AC080CR	M4AC100CR	M4AC120CR	M4AC150CR	
NOMINAL CAPACITY (COOLING / HEATING)		Btu/hr	74000 / 90000	88000 / 98000	110000 / 118000	132000 / 123000
		kcal/hr	18649 / 22681	22177 / 24697	27721 / 29737	33266 / 30997
		Watt	21688 / 26377	25791 / 28722	32239 / 34583	38686 / 36049
CASING	MATERIAL	Electro-galvanized Mild Steel				
	FINISH	Polyester Powder				
	THICKNESS	mm	1.5			
DIMENSION	HEIGHT (H)	mm	1245	1245		
	WIDTH (W)	mm	1500	1800		
	DEPTH (D)	mm	900	1150		
WEIGHT	kg	350	360	480	560	
NOISE LEVEL	dBA	61	62	63	64	
PACKING DIMENSION	HEIGHT (H)	mm	1452	1452		
	WIDTH (W)	mm	1732	2032		
	DEPTH (D)	mm	1032	1282		
CONDENSER COIL						
TYPE		Cross Finned Tubes				
TUBE	MATERIAL	Seamless Copper				
	WALL THICKNESS	mm	0.35			
	OUTER DIAMETER	mm	9.52			
FIN	MATERIAL	Aluminium (Hydrophilic)				
	THICKNESS	mm	0.11			
	ROWS		2	2	2	2
FIN PER INCH			14	14	14	14
TOTAL FACE AREA	m ²	1.37	1.37	1.79	1.79	
EVAPORATOR						
TYPE		Braze Plate Heat Exchanger				
PLATE MATERIAL		Stainless Steel				
NOMINAL WATER FLOW	L/s	1.08 / 1.14	1.31 / 1.37	1.67 / 1.79	2.00 / 2.10	
CONDENSER FAN						
TYPE/DRIVE		Propeller/Direct				
QUANTITY		2		2		
BLADE MATERIAL		Aluminium				
BLADE DIAMETER	INCH	24	26			
POWER SUPPLY	V/Ph/Hz	220-240/1/50				
RATED RUNNING CURRENT	Amp	1.2 x 2	1.2 x 2	1.8 x 2	3.4 x 2	
RATED INPUT(COOLING / HEATING)	Watt	283 x 2		386 x 2		
RATED OUTPUT(COOLING / HEATING)	Watt	120 x 2		200 x 2		
MOTOR POLES		8	8	8	6	
WATER LINE (HYDRAULIC KIT)						
PUMP	TYPE	Horizontal Multistage End-Suction				
	MAX. WATER OPER. PRESSURE	kPa	1000			
	RUNNING CURRENT	Amp	1.5	1.5	2.0	2.0
	WATER FLOW RATE	GPM	17.2 / 18.1	20.7 / 21.7	26.4 / 28.4	31.7 / 33.3
PIPING	INSTALLATION PIPE CONNECTION	mm(in)	42mmBSP(1 ¹ / ₄ "			
	HEAD	m	26/25	23.5/22.5	25/24.5	23/22.5
COMPRESSOR						
TYPE		SCROLL				
POWER SUPPLY	V/Ph/Hz	380-415/3/50				
RATED CURRENT (COOLING / HEATING)	Amp x 2	7.1 / 7.3	8.1 / 8.1	10.5 / 10.3	11.7 / 12.4	
RATED INPUT (COOLING / HEATING)	Watt x 2	4166 / 4180	4707 / 4760	5351 / 5407	6410 / 6746	
MAXIMUM STARTING CURRENT	Amp	65 x 2	74 x 2	76 x 2	95 x 2	
PROTECTION DEVICES	Overload Protection, Differential and H/L Pressure Switch					
STAGE OF CAPACITY CONTROL	ON/OFF					
REFRIGERANT						
TYPE		R407C				
CONTROL		Capillary Tube				
CHARGING MASS	kg	4.0 x 2	3.3 x 2	5.8 x 2	6.1 x 2	

Note : Nominal values are based on 12°C / 7°C entering / leaving evaporator water temperature , 35°C air ambient temperature.

Note : Nominal values are based on 40°C / 45°C entering / leaving evaporator water temperature , 7°C air ambient temperature.

Note : Unit dimension without hydraulic kit.

Performance Table

Cooling Only
Refrigerant: R22

MODEL	AMBIENT TEMPERATURE (°C)													
	19		28		32		35		40		42		46	
	COOL CAP. kW	COMP. INPUT kW	COOL CAP. kW	COMP. INPUT kW	COOL CAP. kW	COMP. INPUT kW	COOL CAP. kW	COMP. INPUT kW	COOL CAP. kW	COMP. INPUT kW	COOL CAP. kW	COMP. INPUT kW	COOL CAP. kW	COMP. INPUT kW
	LEAVING WATER TEMP (°C)													
MAC080C	5	25.4	4.2	23.3	5.3	22.4	5.8	21.7	6.2	19.7	18.8	7.2	17.2	7.8
	6	26.2	4.5	24.0	5.7	23.1	6.2	22.4	6.6	20.3	19.4	7.7	17.8	8.3
	7	26.4	4.7	24.4	6.0	23.5	6.6	22.9	7.0	20.9	20.1	8.1	18.5	8.7
	8	26.7	5.0	24.7	6.3	23.9	6.9	23.2	7.3	21.1	20.2	8.4	18.6	9.1
	9	27.5	5.4	25.5	6.8	24.5	7.4	23.8	7.9	21.6	20.7	9.0	18.9	9.6
MAC100C	10	28.2	5.8	26.0	7.5	25.0	8.2	24.2	8.7	22.2	21.4	9.7	19.7	10.2
	5	28.9	5.0	27.2	6.5	26.5	7.1	25.9	7.6	23.4	22.4	8.9	20.3	9.6
	6	29.8	5.4	28.1	6.9	27.3	7.6	26.7	8.1	24.1	23.1	9.4	21.0	10.2
	7	30.5	5.5	28.7	7.2	27.9	8.0	27.3	8.6	24.8	23.8	9.9	21.8	10.7
	8	30.7	6.0	29.0	7.7	28.2	8.4	27.7	9.0	25.1	24.0	10.4	22.0	11.2
MAC120C	9	31.2	6.5	29.7	8.3	29.0	9.0	28.4	9.6	25.7	24.7	11.1	22.5	11.9
	10	32.1	7.0	30.3	9.1	29.5	10.0	28.9	10.7	26.3	25.2	11.9	23.1	12.6
	5	35.9	6.2	33.9	7.4	33.0	8.0	32.3	8.4	30.1	29.2	9.8	27.3	10.6
	6	37.1	6.5	35.0	7.9	34.0	8.5	33.3	9.0	31.1	30.1	10.4	28.3	11.2
	7	37.3	7.0	35.5	8.3	34.6	9.0	34.0	9.4	31.8	30.9	11.0	29.1	11.9
MAC150C	8	38.1	7.4	36.1	8.8	35.2	9.4	34.5	9.9	32.2	31.3	11.4	29.5	12.3
	9	38.7	7.8	36.9	9.4	36.1	10.1	35.5	10.6	33.0	32.0	12.2	30.1	13.1
	10	39.8	8.5	37.7	10.3	36.7	11.2	36.0	11.8	33.3	32.1	13.8	29.9	15.0
	5	43.2	7.0	40.5	8.8	39.3	9.6	38.4	10.2	35.7	34.6	11.8	32.4	12.7
	6	44.5	7.6	41.6	9.4	40.3	10.3	39.4	10.9	36.7	35.7	12.5	33.6	13.4
MAC150C	7	45.4	8.0	42.6	9.9	41.4	10.8	40.4	11.4	37.8	36.8	13.2	34.7	14.2
	8	45.8	8.4	43.1	10.5	41.9	11.4	41.0	12.0	38.2	37.1	13.7	34.9	14.7
	9	46.7	9.1	44.1	11.2	43.0	12.2	42.2	12.9	39.4	38.3	14.7	36.0	15.8
	10	47.9	9.8	44.9	12.4	43.6	13.5	42.6	14.3	40.0	39.0	15.7	36.9	16.5

CH8-30 PUMP (120 & 150)
CH4-40 PUMP (080 & 100)

**Heat Pump – Cooling Mode
Refrigerant: R22**

MODEL	AMBIENT TEMPERATURE (°C)															
	19		28		32		35		40		42		46			
	COOL CAP. KW	COMP. INPUT KW	COOL CAP. KW	COMP. INPUT KW	COOL CAP. KW	COMP. INPUT KW	COOL CAP. KW	COMP. INPUT KW	COOL CAP. KW	COMP. INPUT KW	COOL CAP. KW	COMP. INPUT KW	COOL CAP. KW	COMP. INPUT KW		
	LEAVING WATER TEMP (°C)															
MAC080CR	5	22.1	4.5	21.6	6.0	21.5	6.6	21.3	7.1	19.7	7.7	19.1	7.9	17.8	8.4	
	6	22.8	4.9	22.4	6.4	22.2	7.1	22.1	7.6	20.4	8.1	19.7	8.4	18.4	8.8	
	7	23.2	5.1	22.8	6.7	22.7	7.4	22.6	8.0	21.0	8.6	20.3	8.9	19.0	9.4	
	8	23.6	5.4	23.3	7.1	23.1	7.8	23.0	8.4	21.3	9.0	20.7	9.2	19.4	9.7	
	9	24.2	5.9	23.8	7.6	23.6	8.4	23.5	9.0	21.7	9.6	21.0	9.9	19.6	10.4	
	10	24.8	6.3	24.5	8.4	24.4	9.3	24.3	10.0	22.4	10.4	21.7	10.6	20.2	11.0	
	MAC100CR	5	27.5	5.3	26.7	6.9	26.3	7.7	26.0	8.2	23.8	9.1	22.9	9.4	21.1	10.1
		6	27.7	5.7	27.3	7.4	27.1	8.2	26.9	8.8	24.7	9.7	23.8	10.0	22.0	10.7
		7	29.0	5.9	28.2	7.8	27.8	8.6	27.5	9.2	25.2	10.2	24.2	10.5	22.4	11.3
		8	29.6	6.3	28.7	8.2	28.3	9.1	28.1	9.7	25.6	10.6	24.7	11.0	22.7	11.7
9		30.2	6.8	29.3	8.8	29.0	9.7	28.7	10.4	26.3	11.3	25.3	11.7	23.4	12.5	
10		31.0	7.4	30.3	9.7	29.9	10.8	29.7	11.5	27.2	12.3	26.2	12.6	24.2	13.3	
MAC120CR		5	33.7	6.2	32.4	7.8	31.8	8.5	31.3	9.1	28.6	9.8	27.5	10.1	25.4	10.7
		6	34.4	6.6	33.3	8.3	32.8	9.1	32.4	9.7	29.7	10.4	28.6	10.7	26.4	11.3
		7	35.2	7.0	34.0	8.8	33.5	9.6	33.2	10.2	30.3	11.0	29.1	11.3	26.8	11.9
		8	35.6	7.4	34.6	9.3	34.1	10.1	33.8	10.7	30.7	11.4	29.5	11.7	27.0	12.3
	9	36.4	8.0	35.4	9.9	34.9	10.8	34.5	11.5	31.5	12.2	30.3	12.5	27.9	13.2	
	10	37.7	8.6	36.6	10.9	36.1	12.0	35.7	12.7	32.6	13.3	31.3	13.5	28.8	14.0	
	MAC150CR	5	39.6	6.9	38.8	8.8	38.5	9.6	38.2	10.3	35.5	11.1	34.4	11.5	32.2	12.1
		6	41.0	7.4	40.2	9.4	39.8	10.3	39.5	11.0	36.7	11.8	35.5	12.2	33.3	12.9
		7	41.6	7.9	40.9	9.9	40.7	10.8	40.4	11.5	37.6	12.5	36.5	12.9	34.3	13.6
		8	42.7	8.3	41.9	10.4	41.5	11.4	41.2	12.1	38.1	13.0	36.9	13.4	34.4	14.1
9		43.6	9.0	42.8	11.2	42.4	12.2	42.1	13.0	39.1	13.9	37.9	14.2	35.5	15.0	
10		45.2	9.7	44.3	12.3	43.9	13.5	43.6	14.4	40.5	15.1	39.2	15.4	36.7	15.9	

CH8-30 PUMP (120 & 150)
CH4-40 PUMP (080 & 100)

**Heat Pump – Heating Mode
Refrigerant: R22**

MODEL	AMBIENT TEMPERATURE (°C)																
	-7		-5		0		4		7		10		15		21		
	HEATING CAP. kW	COMP. INPUT kW	HEATING CAP. kW	COMP. INPUT kW	HEATING CAP. kW	COMP. INPUT kW	HEATING CAP. kW	COMP. INPUT kW	HEATING CAP. kW	COMP. INPUT kW	HEATING CAP. kW	COMP. INPUT kW	HEATING CAP. kW	COMP. INPUT kW	HEATING CAP. kW	COMP. INPUT kW	
	LEAVING WATER TEMP (°C)																
	35	16.5	4.2	18.1	4.6	22.2	5.4	25.4	6.1	27.8	6.6	33.7	8.2	43.6	10.7	55.5	13.8
	40	16.1	4.8	17.7	5.1	21.6	6.0	24.7	6.7	27.0	7.3	32.8	8.8	42.6	11.2	54.2	14.2
MAC080CR	45	15.8	5.1	17.3	5.5	21.1	6.4	24.1	7.1	26.4	7.7	32.3	9.3	42.1	11.9	53.8	15.0
	50	15.2	5.1	16.7	5.5	20.5	6.5	23.5	7.4	25.8	8.0	31.6	9.7	41.2	12.4	52.7	15.7
	55	14.5	5.2	16.0	5.6	19.7	6.7	22.7	7.7	24.9	8.4	30.5	10.0	39.9	12.8	51.2	16.2
	35	20.7	6.5	22.6	6.6	27.3	7.0	31.0	7.2	33.8	7.5	35.7	7.9	38.7	8.6	42.3	9.4
	40	20.3	7.3	22.1	7.4	26.6	7.7	30.2	8.0	32.9	8.2	34.8	8.5	37.9	9.1	41.7	9.7
MAC100CR	45	19.5	8.1	21.4	8.2	25.9	8.4	29.5	8.6	32.2	8.7	34.1	8.9	37.2	9.3	41.0	9.8
	50	19.0	8.2	20.8	8.3	25.3	8.6	28.9	8.8	31.6	9.0	33.4	9.4	36.4	9.9	40.0	10.6
	55	18.1	8.3	19.9	8.5	24.3	8.9	27.8	9.2	30.4	9.4	32.2	9.8	35.3	10.3	39.0	11.0
	35	21.1	7.3	23.0	7.5	28.8	8.1	33.5	8.6	36.9	8.9	39.1	9.1	42.6	9.5	46.9	9.9
	40	19.9	8.2	22.2	8.5	27.9	9.0	32.4	9.4	35.9	9.8	38.0	9.9	41.6	10.0	45.9	10.2
MAC120CR	45	19.7	8.8	22.0	9.1	27.5	9.6	31.9	10.0	35.2	10.4	37.3	10.4	40.8	10.4	45.1	10.5
	50	19.3	9.1	21.2	9.3	26.7	9.9	31.1	10.4	34.5	10.8	36.6	10.9	40.2	11.1	44.4	11.3
	55	18.2	9.3	20.2	9.6	25.6	10.3	30.0	10.8	33.2	11.3	35.3	11.3	38.9	11.5	43.2	11.6
	35	21.5	8.8	23.8	9.0	30.8	9.7	36.4	10.2	40.6	10.6	42.1	10.7	44.7	11.1	47.8	11.4
	40	20.5	9.9	23.2	10.2	30.0	10.8	35.4	11.2	39.5	11.6	41.1	11.6	43.8	11.7	47.0	11.8
MAC150CR	45	20.1	10.4	22.8	10.7	29.4	11.4	34.7	11.9	38.7	12.3	40.3	12.2	43.0	12.2	46.2	12.1
	50	19.6	10.6	22.2	10.9	28.7	11.7	34.0	12.3	37.9	12.8	39.4	12.8	41.9	12.9	44.9	13.0
	55	18.5	10.7	20.9	11.1	27.4	12.0	32.6	12.8	36.5	13.3	38.0	13.4	40.6	13.4	43.6	13.4

CH8-30 PUMP (120 & 150)
CH4-40 PUMP (080 & 100)

**Cooling Only
Refrigerant: R 407C**

MODEL	AMBIENT TEMPERATURE (°C)														
	19		28		32		35		40		42		46		
	COOL CAP. KW	COMP. INPUT KW	COOL CAP. KW	COMP. INPUT KW	COOL CAP. KW	COMP. INPUT KW	COOL CAP. KW	COMP. INPUT KW	COOL CAP. KW	COMP. INPUT KW	COOL CAP. KW	COMP. INPUT KW	COOL CAP. KW	COMP. INPUT KW	
	5	24.0	4.6	21.9	6.1	21.1	6.6	20.6	6.9	19.3	7.3	17.4	7.8	15.0	8.5
	6	24.7	4.9	22.6	6.6	22.2	7.1	21.3	7.4	20.0	7.8	18.0	8.3	15.5	9.1
M4AC080C	7	24.9	5.1	23.0	6.9	22.3	7.5	21.7	7.8	20.4	8.2	18.6	8.7	16.1	9.5
	8	25.2	5.5	23.2	7.3	22.6	7.9	22.0	8.2	20.8	8.6	18.7	9.1	16.2	9.9
	9	26.0	5.9	23.6	7.9	23.1	8.5	22.6	8.8	21.4	9.2	19.1	9.7	16.5	10.5
	10	26.6	6.4	24.3	8.5	23.4	9.1	23.0	9.8	22.1	9.8	19.8	10.3	17.2	11.2
	5	26.5	5.2	25.5	7.2	24.9	7.8	24.5	8.2	23.2	8.7	21.6	9.2	18.9	10.0
M4AC100C	6	27.3	5.6	26.3	7.7	26.1	8.4	25.3	8.7	24.0	9.2	22.3	9.8	19.5	10.6
	7	27.9	5.7	26.7	8.1	26.2	8.8	25.8	9.2	24.5	9.7	23.0	10.3	20.3	11.1
	8	28.1	6.2	27.1	8.6	26.6	9.3	26.2	9.7	25.0	10.1	23.2	10.7	20.4	11.6
	9	28.6	6.7	27.5	9.3	27.2	10.0	26.9	10.4	25.7	10.8	23.7	11.4	20.9	12.3
	10	29.4	7.2	28.3	10.0	27.6	10.8	27.3	11.5	26.5	11.6	24.6	12.2	21.5	13.1
	5	34.1	6.3	33.4	8.0	32.6	8.7	32.0	9.1	30.4	9.6	28.2	10.2	26.3	11.5
M4AC120C	6	35.2	6.7	34.5	8.6	34.2	9.3	33.0	9.7	31.4	10.2	29.3	10.9	27.2	12.2
	7	35.5	7.1	35.0	9.0	34.3	9.8	33.7	10.2	32.0	10.7	30.2	11.4	28.0	12.9
	8	36.2	7.5	35.5	9.5	34.8	10.3	34.2	10.7	32.7	11.2	30.4	11.9	28.3	13.3
	9	36.8	8.0	36.1	10.3	35.6	11.1	35.2	11.5	33.7	12.0	31.1	12.7	28.9	14.2
	10	37.8	8.7	37.1	11.1	36.1	11.9	35.7	12.8	34.7	12.8	32.2	13.5	29.9	15.0
	5	42.5	7.6	41.3	9.5	39.6	10.4	38.2	10.9	37.0	11.5	34.9	12.3	31.8	14.0
M4AC150C	6	43.8	8.2	42.6	10.3	41.5	11.1	39.4	11.6	38.2	12.2	36.1	13.0	32.9	14.8
	7	44.7	8.6	43.3	10.8	42.0	11.7	40.2	12.2	39.0	12.8	37.3	13.7	34.0	15.6
	8	45.1	9.1	43.8	11.4	42.4	12.3	40.8	12.8	39.8	13.4	37.6	14.2	34.2	16.2
	9	45.9	9.9	44.6	12.3	43.1	13.3	41.9	13.7	41.0	14.3	38.4	15.2	35.3	17.4
	10	47.2	10.6	45.8	13.3	44.0	14.3	42.6	15.3	42.2	15.3	39.8	16.1	36.2	18.2

CH8-30 PUMP (120 & 150)
CH4-40 PUMP (080 & 100)

**Heat Pump - Cooling Only
Refrigerant: R 407C**

MODEL	AMBIENT TEMPERATURE (°C)													
	19		28		32		35		40		42		46	
	COOL CAP. kW	COMP. INPUT kW	COOL CAP. kW	COMP. INPUT kW	COOL CAP. kW	COMP. INPUT kW	COOL CAP. kW	COMP. INPUT kW	COOL CAP. kW	COMP. INPUT kW	COOL CAP. kW	COMP. INPUT kW	COOL CAP. kW	COMP. INPUT kW
M4AC080CR	5	21.2	4.7	20.8	6.5	20.6	7.1	20.5	7.4	19.4	18.1	8.3	16.8	8.9
	6	21.9	5.1	21.5	7.0	21.3	7.6	21.2	7.9	20.1	18.9	8.8	17.4	9.4
	7	22.3	5.3	22.0	7.4	21.8	8.0	21.7	8.3	20.6	19.2	9.3	18.0	10.0
	8	22.7	5.7	22.4	7.8	22.2	8.4	22.1	8.7	20.9	19.5	9.7	18.3	10.3
	9	23.2	6.2	22.9	8.4	22.7	9.1	22.6	9.3	21.5	20.1	10.3	18.5	11.0
	10	23.8	6.6	23.6	9.1	23.5	9.7	23.4	10.4	22.1	20.8	11.0	19.1	11.6
	5	25.9	5.4	25.0	7.7	24.7	8.4	24.4	8.8	23.1	21.5	9.9	20.0	10.5
	6	26.1	5.8	25.6	8.3	25.4	9.0	25.2	9.4	23.9	22.4	10.5	20.9	11.1
	7	27.3	6.0	26.5	8.7	26.1	9.5	25.8	9.8	24.5	22.8	11.0	21.3	11.7
	8	27.8	6.4	26.9	9.2	26.6	9.9	26.3	10.3	24.9	23.2	11.5	21.6	12.1
M4AC100CR	9	28.4	7.0	27.5	9.9	27.2	10.7	26.9	11.1	25.5	23.9	12.2	22.3	13.0
	10	29.2	7.5	28.4	10.7	28.1	11.5	27.8	12.3	26.3	24.8	13.0	23.0	13.8
	5	33.2	6.3	31.7	8.6	31.0	9.4	30.5	9.8	28.9	26.9	11.1	24.5	12.0
	6	33.9	6.8	32.6	9.3	32.0	10.1	31.5	10.5	29.9	28.1	11.8	25.5	12.7
	7	34.7	7.2	33.3	9.8	32.7	10.6	32.2	11.0	30.6	28.5	12.4	25.9	13.4
	8	35.1	7.6	33.8	10.3	33.3	11.2	32.9	11.6	31.1	29.0	12.9	26.1	13.8
	9	35.9	8.1	34.6	11.2	34.0	12.0	33.6	12.4	31.9	29.9	13.7	26.9	14.8
	10	37.2	8.8	35.8	12.0	35.2	12.9	34.8	13.8	32.9	31.0	14.6	27.9	15.7
	5	39.0	7.6	37.6	9.7	37.0	10.6	36.6	11.1	34.6	32.3	12.5	31.3	13.7
	6	40.4	8.2	39.0	10.5	38.3	11.4	37.8	11.9	35.9	33.7	13.3	32.3	14.5
M4AC150CR	7	41.0	8.6	39.7	11.0	39.1	12.0	38.7	12.5	36.7	34.2	14.0	33.3	15.3
	8	42.1	9.1	40.6	11.7	39.9	12.6	39.4	13.1	37.3	34.8	14.5	33.4	15.9
	9	43.0	9.8	41.5	12.6	40.8	13.6	40.3	14.0	38.3	35.9	15.5	34.5	16.8
	10	44.5	10.6	42.9	13.6	42.2	14.6	41.7	15.6	39.5	37.1	16.5	35.7	17.9

CH8-30 PUMP (120 & 150)
CH4-40 PUMP (080 & 100)

**Heat Pump - Heating Mode
Refrigerant: R 407C**

MODEL	LEAVING WATER TEMP (°C)	AMBIENT TEMPERATURE (°C)															
		-7		-5		0		4		7		10		15		21	
		HEATING CAP. kW	COMP. INPUT kW	HEATING CAP. kW	COMP. INPUT kW	HEATING CAP. kW	COMP. INPUT kW	HEATING CAP. kW	COMP. INPUT kW	HEATING CAP. kW	COMP. INPUT kW	HEATING CAP. kW	COMP. INPUT kW	HEATING CAP. kW	COMP. INPUT kW	HEATING CAP. kW	COMP. INPUT kW
M4AC080CR	35	16.0	6.4	18.6	6.5	25.1	6.7	26.9	6.9	27.7	7.2	28.3	7.7	29.5	8.2	33.6	8.5
	40	15.6	7.2	18.2	7.3	24.5	7.5	26.1	7.8	26.9	7.9	27.9	8.1	29.1	8.4	32.9	8.7
	45	15.2	7.7	17.7	7.8	24.0	7.9	25.6	8.2	26.4	8.4	27.4	8.5	28.5	8.9	32.6	9.2
	50	14.6	7.8	17.2	7.9	23.5	8.0	25.1	8.5	25.9	8.7	26.9	9.0	28.0	9.3	31.9	9.6
	55	14.0	7.9	16.4	8.0	22.4	8.2	24.4	8.8	24.9	9.1	26.1	9.2	27.2	9.6	31.0	9.9
M4AC100CR	35	16.9	7.3	19.2	7.4	27.3	7.6	29.3	7.8	30.2	8.2	30.8	8.7	32.2	9.3	36.4	9.5
	40	16.5	8.1	18.7	8.3	26.7	8.6	28.4	8.8	29.3	9.0	30.4	9.2	31.7	9.6	35.8	9.8
	45	15.9	9.0	18.1	9.1	26.1	9.2	27.8	9.3	28.7	9.5	29.8	9.7	31.1	9.8	35.2	9.9
	50	15.5	9.1	17.7	9.2	25.6	9.5	27.3	9.7	28.2	9.9	29.2	10.3	30.5	10.6	34.3	10.7
	55	14.8	9.3	16.8	9.4	24.4	9.7	26.6	10.0	27.1	10.3	28.4	10.5	29.6	10.9	33.5	11.1
M4AC120CR	35	18.6	8.3	22.7	8.4	32.9	8.6	35.3	8.9	36.3	9.3	37.1	9.9	38.7	10.6	42.6	10.9
	40	17.9	9.3	21.9	9.4	32.2	9.7	34.2	10.0	35.3	10.2	36.6	10.5	38.1	10.9	41.8	11.2
	45	17.6	10.0	21.7	10.1	31.5	10.4	33.5	10.5	34.6	10.8	35.9	11.0	37.4	11.2	41.0	11.6
	50	16.9	10.3	20.9	10.4	30.8	10.7	32.9	11.0	33.9	11.2	35.2	11.7	36.7	12.0	40.4	12.4
	55	16.2	10.5	20.0	10.7	29.4	11.0	32.0	11.3	32.7	11.7	34.2	11.9	35.7	12.4	39.3	12.8
M4AC150CR	35	19.4	10.0	23.7	10.3	34.3	10.8	36.8	11.1	37.9	11.6	38.6	12.4	40.4	13.2	44.4	13.6
	40	18.9	11.3	23.1	11.6	33.5	12.2	35.7	12.6	36.8	12.7	38.2	13.1	39.7	13.6	43.7	14.0
	45	18.6	11.9	22.7	12.2	32.8	12.8	34.9	13.2	36.1	13.5	37.4	13.8	39.0	14.0	42.9	14.4
	50	18.1	12.1	22.1	12.4	32.1	13.0	34.3	13.8	35.3	14.0	36.7	14.6	38.3	15.0	41.7	15.5
	55	16.9	12.3	20.8	12.6	30.6	13.3	33.4	14.2	34.0	14.7	35.7	14.9	37.2	15.5	40.5	16.0

CH8-30 PUMP (120 & 150)
CH4-40 PUMP (080 & 100)

Technical Data

Water Pressure Drop

MAC/M4AC080C/CR

Flowrate (m3/hr)	Pressure drop (psig)	BPHE (kPa)	Pump head (kPa)	Hydraulic life (kPa)	Unit Water Piping (psig)	Unit Pressure Drop (psig)	Total Pressure Drop (kPa)
2.4	2.0	14	300	281	0.7	2.7	18.7
3.2	3.6	25	270	237	1.1	4.7	32.6
4	5.5	38	260	211	1.7	7.2	49.3
4.8	7.8	54	230	160	2.3	10.1	69.6
5.6	10.6	73	200	106	3.0	13.6	93.5
6.4	13.8	95	175	54	3.8	17.6	121.0

MAC/M4AC100C/CR

Flowrate (m3/hr)	Pressure drop (psig)	BPHE (kPa)	Pump head (kPa)	Hydraulic lift (kPa)	Unit Water Piping (psig)	Unit Pressure Drop (psig)	Total Pressure Drop (kPa)
3	2.3	16	280	257	1.0	3.3	22.9
4	4.1	28	260	221	1.7	5.7	39.3
5	6.2	43	220	160	2.4	8.7	59.8
6	8.8	61	180	96	3.4	12.2	84.2
7	11.9	82	150	37	4.5	16.3	112.6

MAC/M4AC120C/CR

Flowrate (m3/hr)	Pressure drop (psig)	BPHE (kPa)	Pump head (kPa)	Hydraulic lift (kPa)	Unit Water Piping (psig)	Unit Pressure Drop (psig)	Total Pressure Drop (kPa)
3	1.4	9.7	280	263	1.0	2.4	16.6
4	2.5	17	270	241	1.7	4.1	28.6
5	3.8	26.4	260	216	2.5	6.3	43.6
6	5.5	37.7	250	188	3.5	8.9	61.5
7	7.4	51	230	148	4.6	12.0	82.4

MAC/ M4AC150C/CR

Flowrate (m3/hr)	Pressure drop (psig)	BPHE (kPa)	Pump head (kPa)	Hydraulic lift (kPa)	Unit Water Piping (psig)	Unit Pressure Drop (psig)	Total Pressure Drop (kPa)
3	1.0	6.9	280	266	1.0	2.0	13.8
4	1.8	12.1	270	246	1.7	3.4	23.7
5	2.7	18.8	260	224	2.5	5.2	36.0
6	3.9	26.9	250	199	3.5	7.4	50.7
7	5.3	36.4	230	162	4.6	9.8	67.8
8	6.9	47.3	210	123	5.8	12.6	87.1

Correction Factors with GLYCOL use

LWT/ deg C	CAPACITY FACTOR			
	GLYCOL			
	10	20	30	40
-12.2			0.8	0.7
-9.4			0.827	0.735
-6.7		0.88	0.85	0.756
-3.9		0.9	0.876	0.781
-1.1	0.925	0.925	0.892	0.796
1.7	0.945	0.938	0.906	0.809
4.4	0.956	0.949	0.918	0.82
7.2	0.965	0.959	0.927	0.829
10.0	0.962	0.957	0.926	0.828

GLYCOL %	WATER FLOW	PRESSURE DROP
10	1.015	1.06
20	1.04	1.12
30	1.08	1.18
40	1.135	1.24

Outlines and Dimensions

Model : M4AC/ MAC080/ 100 C/CR

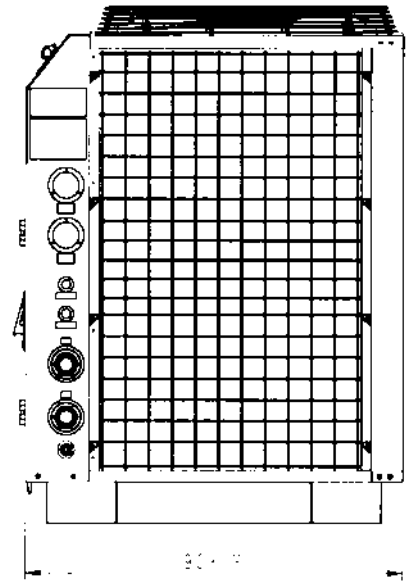
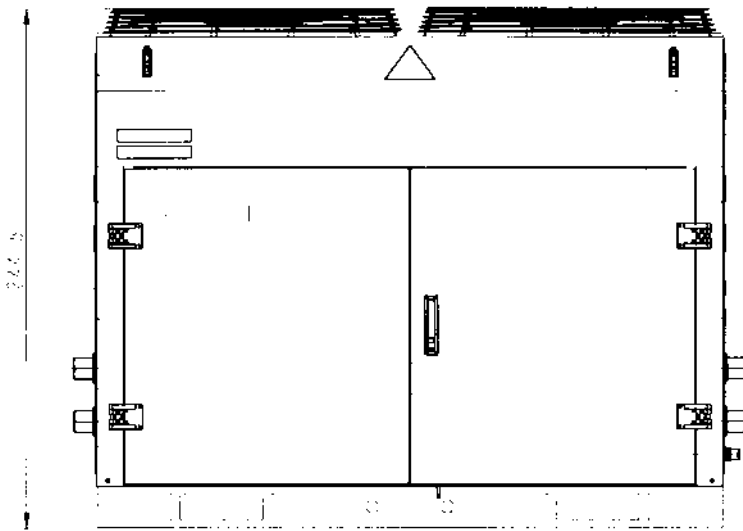
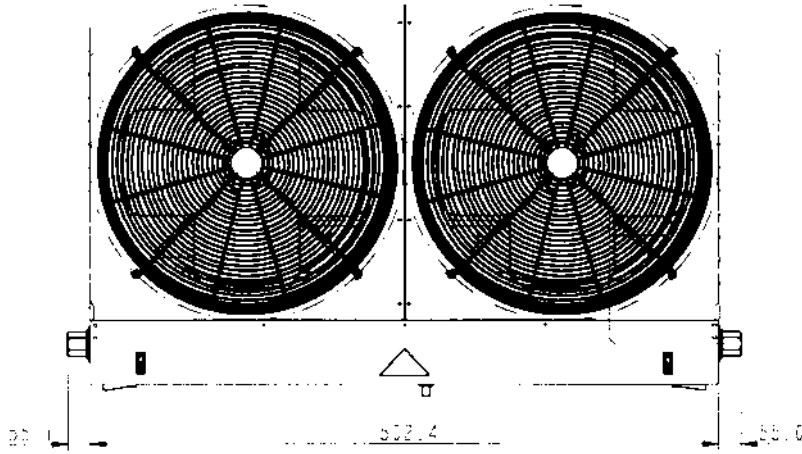

Model : M4AC/ MAC120/150 C/CR

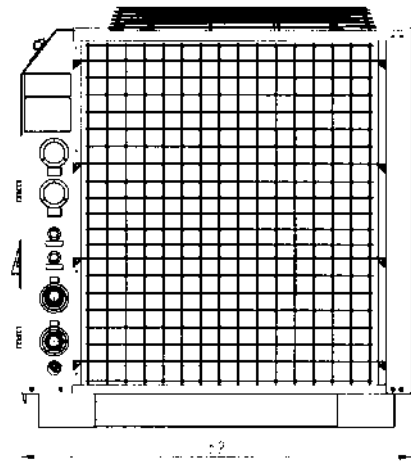
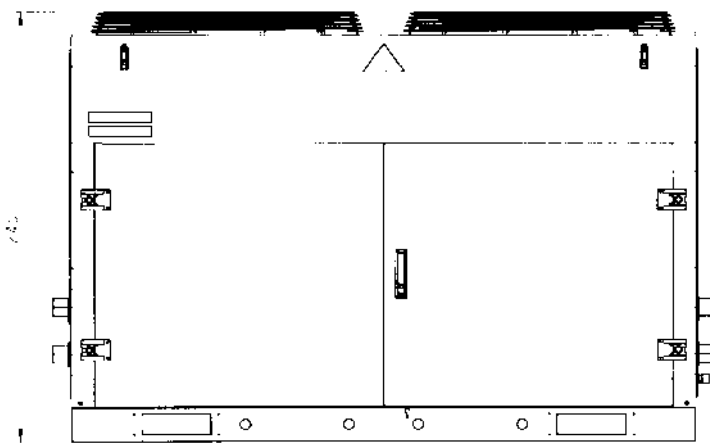
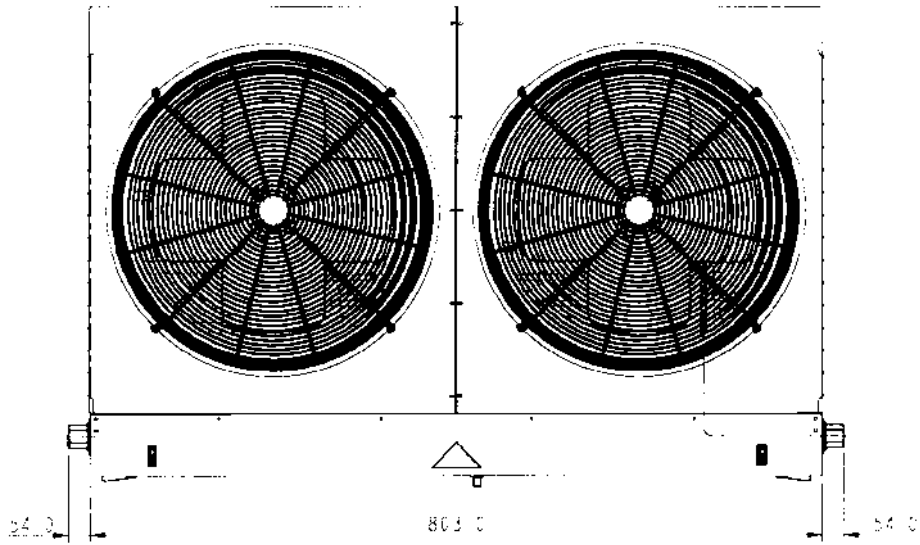

Accessory Hydraulic Kit (Optional)

Hydraulic kit consists of 135L capacity water storage buffer tank, over pressure release valve and drainage point.

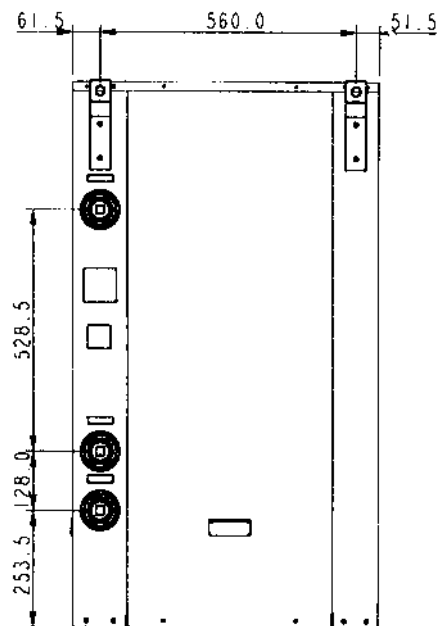
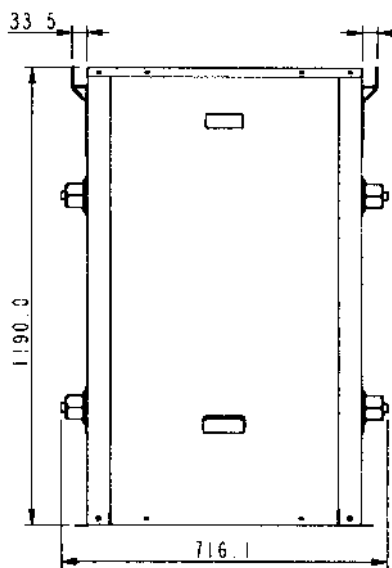
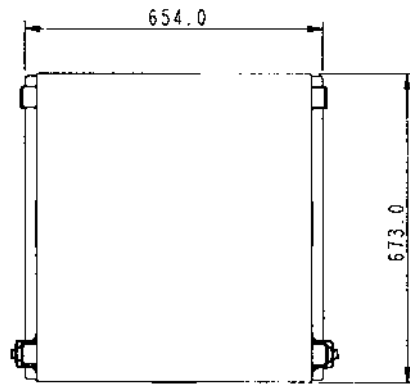

Wiring Diagrams

Model : M4AC / MAC080 / 100 / 120 /150C (Isolator Switch)

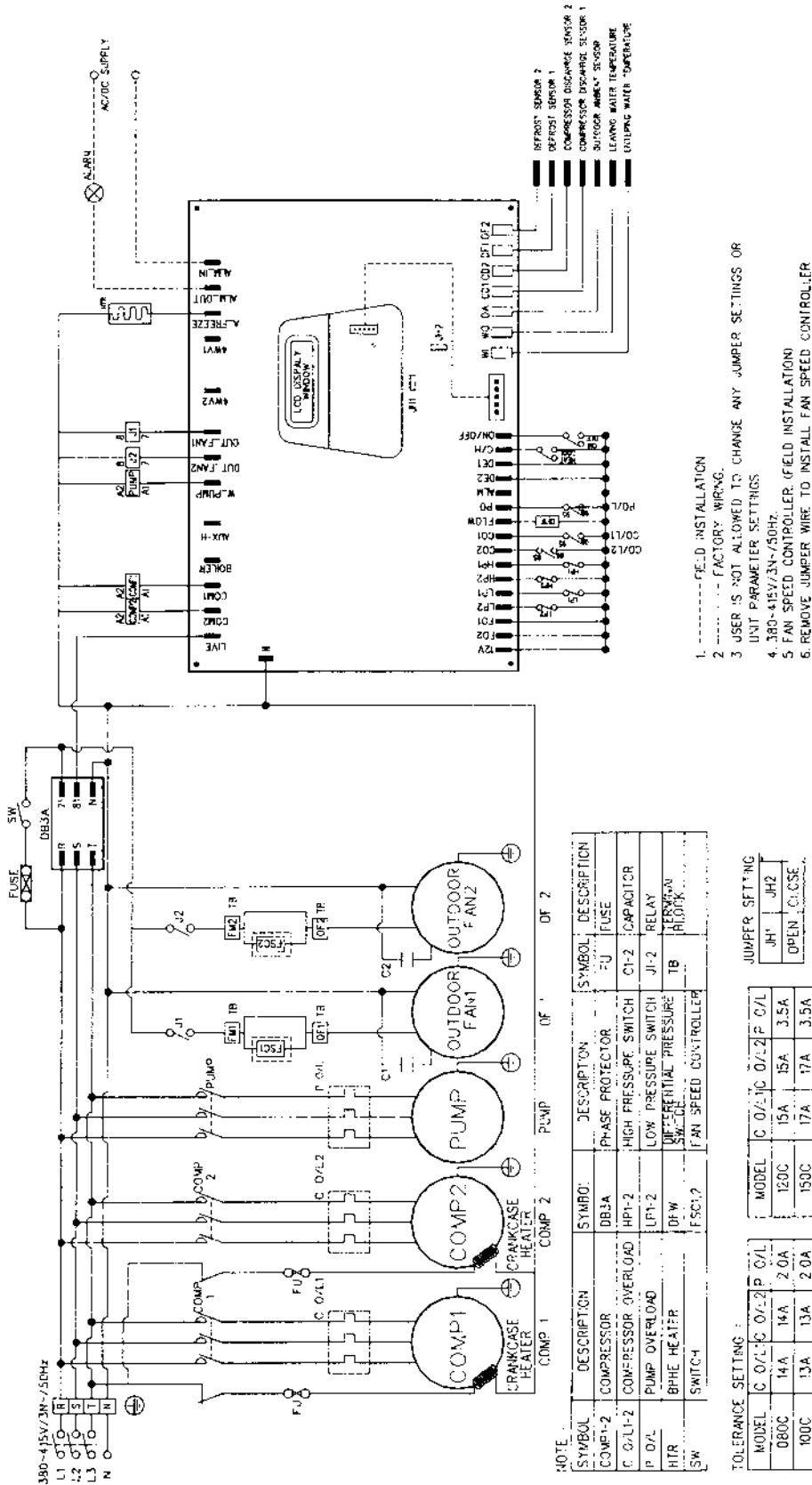

1. ----- FIELD INSTALLATION
2. - - - - - FACTORY WIRING.
3. USER IS NOT ALLOWED TO CHANGE ANY JUMPER SETTINGS OR UNIT PARAMETER SETTINGS
4. 180-415V/3N/50HZ
5. FAN SPEED CONTROLLER (FIELD INSTALLATION)
6. REMOVE JUMPER WIRE TO INSTALL FAN SPEED CONTROLLER

Model : M4AC / MAC080 / 100 / 120 / 150C (Terminal Block)

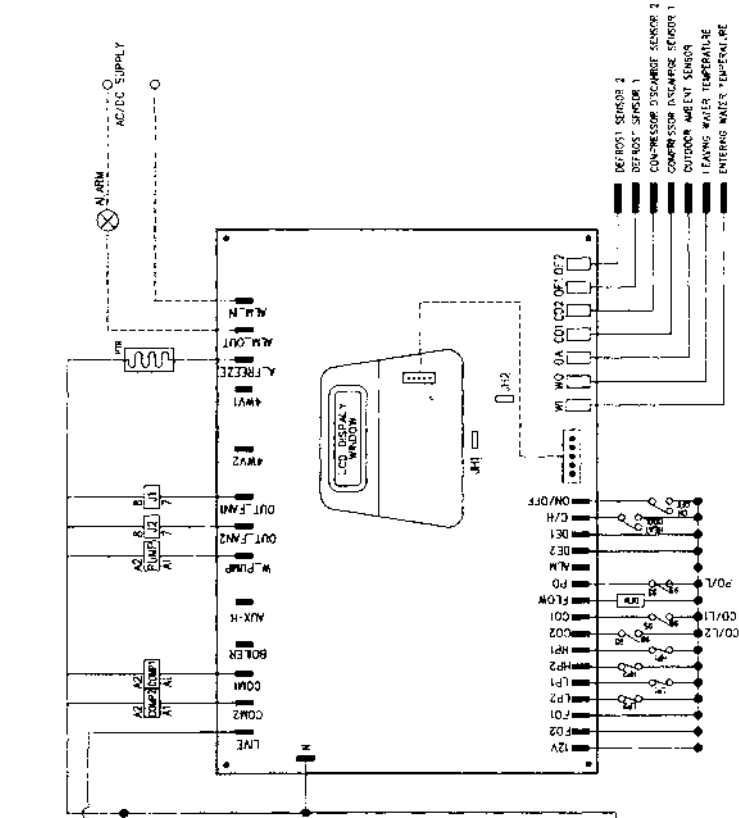

1. FIELD INSTALLATION.
2. FACTORY WIRING.
3. USER IS NOT ALLOWED TO CHANGE ANY JUMPER SETTINGS OR UNIT PARAMETER SETTINGS.
4. 380-415V/3N~/50HZ.
5. FAN SPEED CONTROLLER (FIELD INSTALLATION)
6. REMOVE JUMPER WIRE TO INSTALL FAN SPEED CONTROLLER

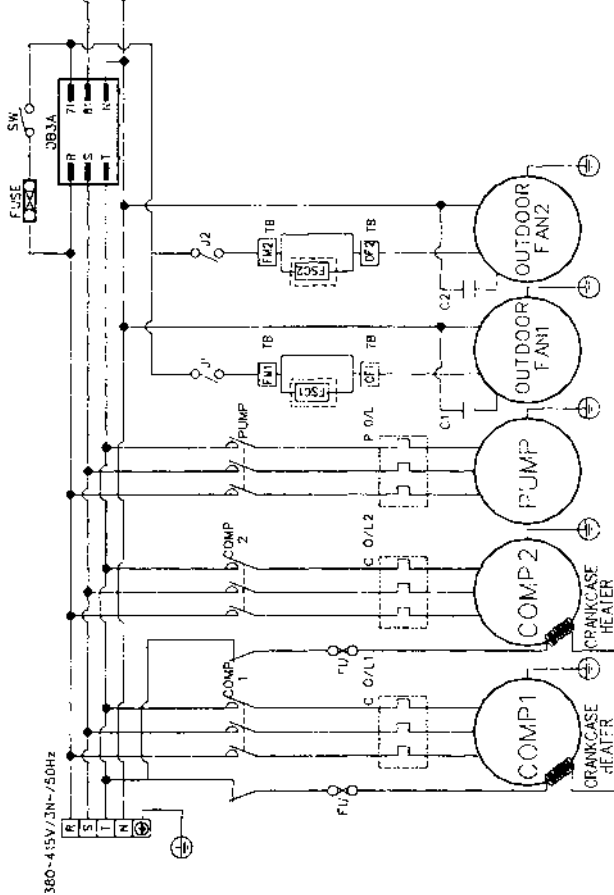

NOTE :

SYMBOL	DESCRIPTION	SYMBOL	DESCRIPTION	SYMBOL	DESCRIPTION
COMP-2	COMPRESSOR	OB3A	PHASE PROTECTOR	FU	FUSE
C O/L1-2	COMPRESSOR OVERLOAD	HP-2	HIGH PRESSURE SWITCH	C-2	CAF-FACTOR
P O/L	PUMP OVERLOAD	LP-2	LOW PRESSURE SWITCH	J-2	RELAY
H-R	BI-E HEATER	DFW	DIFFERENTIAL PRESSURE SWITCH	TB	TERMINAL BLOCK
SW	SWITCH	FSC-2	FAN SPEED CONTROLLER		

TOLERANCE SETTING :

MODEL	C O/L1	C O/L2	P O/L	JUMPER SETTING
080C	14A	14A	2.0A	JH1 JH2
100C	13A	13A	2.0A	OPEN CLOSE
	120C	15A	3.5A	
	150C	17A	3.5A	

Model : M4AC / MAC080 / 100 / 120 / 150CR (Isolator Switch)

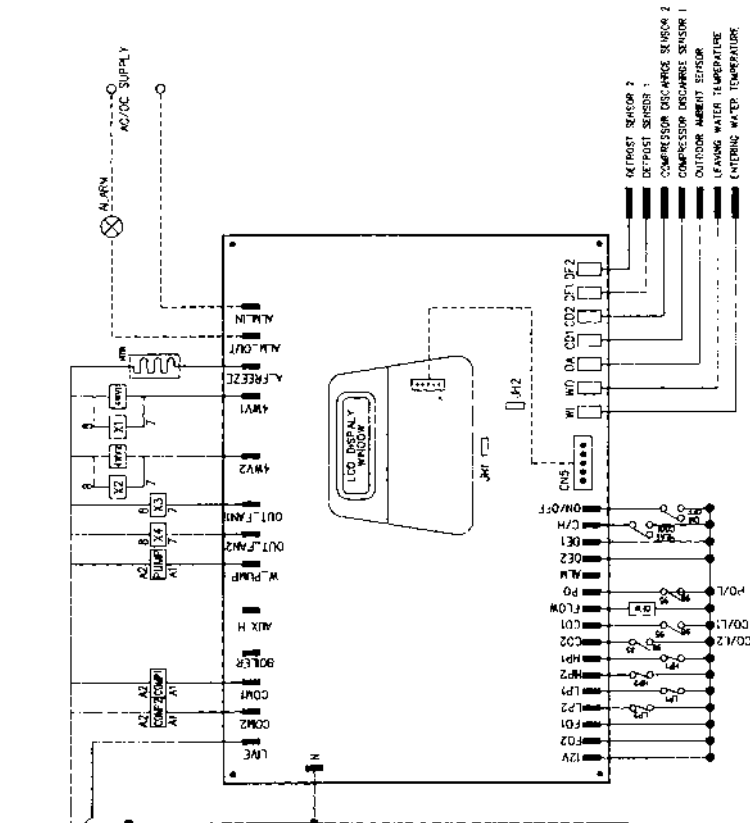

- 1 - - - - - FIELD INSTALLATION
- 2 - - - - - FACTORY WIRING.
3. USER IS NOT ALLOWED TO CHANGE ANY JUMPER SETTINGS OR UNIT PARAMETER SETTINGS
- 4 380-415V/3N~/50Hz
- 5 FAN SPEED CONTROLLER (FIELD INSTALLATION).

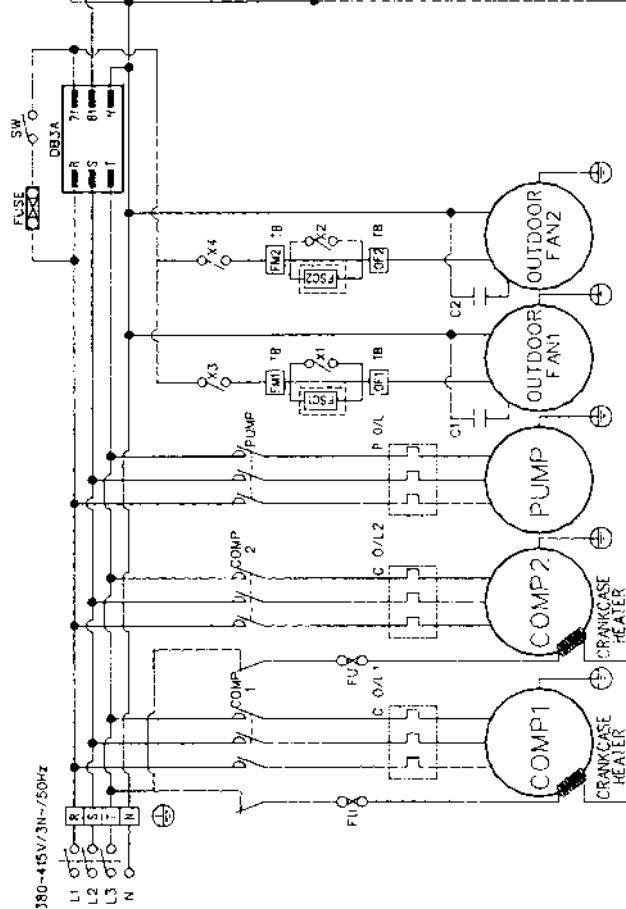

NOTE : OF 1 OF 2

SYMBOL	DESCRIPTION	SYMBOL	DESCRIPTION	SYMBOL	DESCRIPTION
COMP1-2	COMPRESSOR	DB3A	PHASE PROTECTOR	FU	FUSE
C O/L1-2	COMPRESSOR OVERLOAD	HP1-2	HIGH PRESSURE SWITCH	C1-2	CAPACITOR
P O/L	PUMP OVERLOAD	LP1-2	LOW PRESSURE SWITCH	4WV1-2	4 WAY VALVE
HTR	HPHE HEATER	DFW	DIFFERENTIAL PRESSURE SWITCH	X1-4	RELAY
SW	SWITCH	FSC1,2	FAN SPEED CONTROLLER	TB	TERMINAL BLOCK

TOLERANCE SETTING :

MODEL	C O/L1C	O/L2P	O/L
080CR	14A	14A	2.0A
100CR	13A	13A	2.0A

JUMPER SETTING :

MODEL	JH1	JH2
120CR	15A	15A
150CR	17A	17A

Model : M4AC / MAC080 / 100 / 120 / 150CR (Terminal Block)

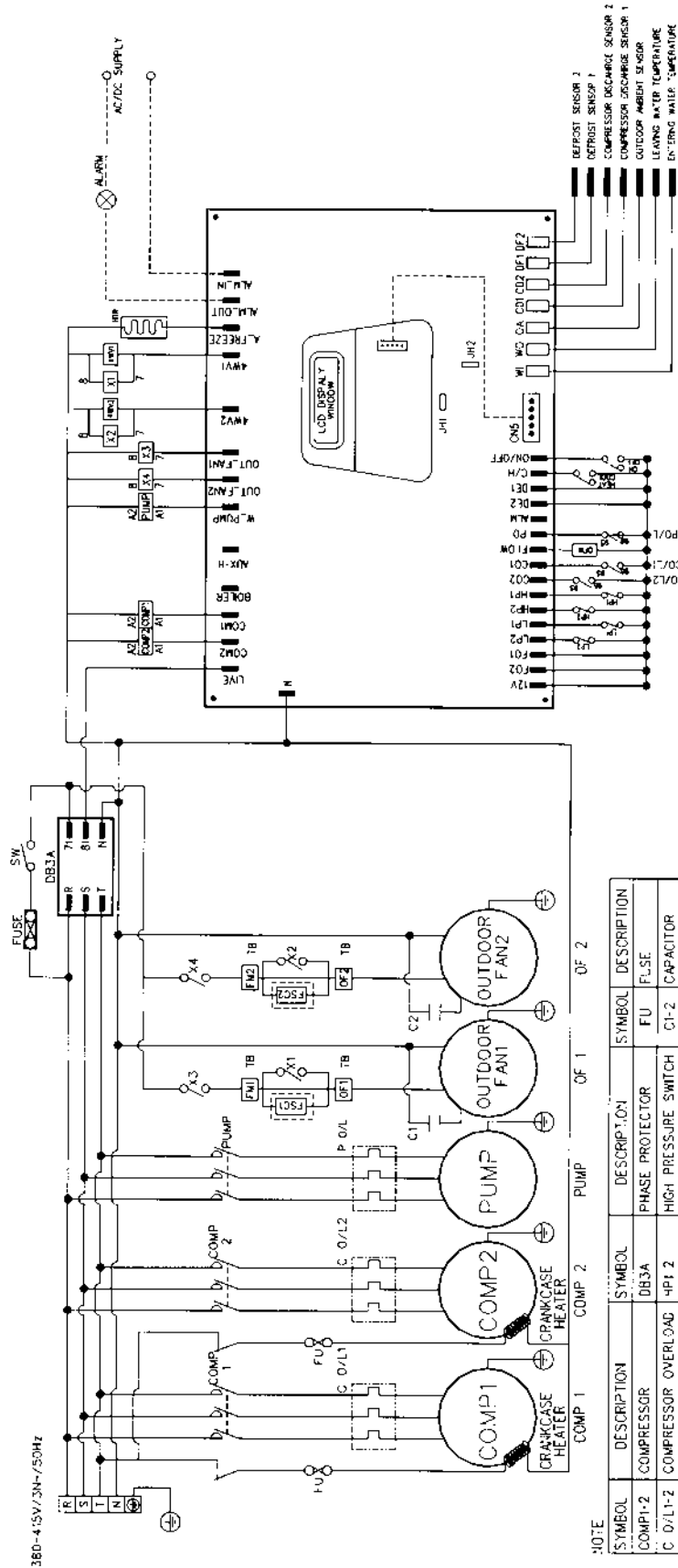

1. ----- FIELD INSTALLATION.
2. _____ FACTORY WIRING.
3. USER IS NOT ALLOWED TO CHANGE ANY JUMPER SETTINGS OR UNIT PARAMETER SETTINGS
4. 380-415V/3N~/50HZ.
5. FAN SPEED CONTROLLER (FIELD INSTALLATION).

NOTE

SYMBOL	DESCRIPTION	SYMBOL	DESCRIPTION	SYMBOL	DESCRIPTION
COMP1-2	COMPRESSOR	DB3A	PHASE PROTECTOR	FU	FUSE
C O/L1-2	COMPRESSOR OVERLOAD	HPI-2	HIGH PRESSURE SWITCH	C1-2	CAPACITOR
P O/L	PUMP OVERLOAD	LPI-2	LOW PRESSURE SWITCH	4WVF-2	4-WAY VALVE
HTR	BEHE HEATER	DFW	DIFFERENTIAL PRESSURE SWITCH	X1-4	RELAY
SW	SWITCH	FSC1,2	FAN SPEED CONTROLLER	TB	TERMINAL BOX

TOLERANCE SETTING :

MODEL	C O/L1/C O/L2	P O/L	JUMPER SETTING
080CR	14A	14A	2.0A
100CR	13A	13A	2.0A
120CR	15A	15A	3.5A
150CR	17A	17A	3.5A

Special Precautions for R407C

1) What is new refrigerant R407C?

R407C is a zeotropic refrigerant mixture which has zero ozone depletion potential and thus conformed to the Montreal Protocol regulation. It requires Polyol ester oil (POE) oil for its compressor's lubricant. Its refrigerant capacity and performance are about the same as the refrigerant R22.

2) Components

Mixture weight composition R32(23%), R125(25%), R134a(52%)

3) Characteristic

- R407C liquid and vapor components have different compositions when the fluid evaporates or condenses. Hence, when leak occurs and only vapor leaks out, the composition of the refrigerant mixture left in the system will change and subsequently affect the system performance. If just additional refrigerant is added to leaked system, system performance will drop. It is recommended that the system should be evacuated thoroughly before recharging with R407C.
- When refrigerant R407C is used, the composition will differ depending on whether it is in gaseous or liquid phase. Hence when charging R407C, ensure that only liquid is being withdrawn from the cylinder or can. This is to make certain that only original composition of R407C is being charged into the system.
- POE oil is used as lubricant for R407C compressor, which is different from the mineral oil used for R22 compressor. Extra precaution must be taken not to expose the R407C system too long to moist air.

4) Check list before installation/servicing

- Tubing
Refrigerant R407C is more easily affected by dust or moisture compared with R22, make sure to temporarily cover the ends of the tubing prior to installation
- Compressor oil
No additional charge of compressor oil is permitted.
- Refrigerant
No other refrigerant other than R407C
- Tools
Tools specifically for R407C only (must not be used for R22 or other refrigerant)
 - i) Manifold gauge and charging hose
 - ii) Gas leak detector
 - iii) Refrigerant cylinder/charging cylinder
 - iv) Vacuum pump c/w adapter
 - v) Flare tools
 - vi) Refrigerant recovery machine

5) Handling and installation guidelines

Like R22 system, the handling and installation of R407C system are closely similar. All precautionary measures; such as ensuring no moisture, no dirt or chips in the system, clean brazing using nitrogen, and thorough leak check and vacuuming are equally important requirements. However, due to zeotropic nature of R407C and its hygroscopic POE oil, additional precautions must be taken to ensure optimum and trouble-free system operation.

- a) Filter-dryer must be installed along the liquid line for all R407C air conditioners. This is to minimise the contamination of moisture and dirt in the refrigerant system. Filter-dryer must be of molecular sieve type. For a heat-pump system, install a two-way flow filter dryer along the liquid line.
- b) During installation or servicing, avoid prolong exposure of the internal part of the refrigerant system to moist air. Residual POE oil in the piping and components can absorb moisture from the air.

- c) Ensure that the compressor is not exposed to open air for more than the recommended time specified by its manufacturer (typically less than 10 minutes). Remove the seal-plugs only when the compressor is about to be brazed.
- d) The system should be thoroughly vacuumed to 1.0 Pa (-700mmHg) or lower. This vacuuming level is more stringent than R22 system so as to ensure no incompressible gas and moisture in the system.
- e) When charging R407C, ensure that only liquid is being withdrawn from the cylinder or can. This is to ensure that only the original composition of R407C is being delivered into the system. The liquid composition can be different from the vapor composition.

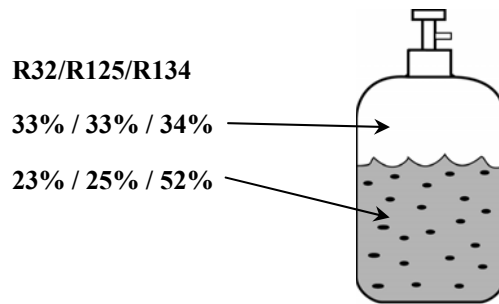

Composition of R407C in vapor phase is different from liquid phase.

- f) Normally, the R407C cylinder or can is being equipped with a dip-pipe for liquid withdrawal. However, if the dip-pipe is not available, invert the cylinder or can so as to withdraw liquid from the valve at the bottom.

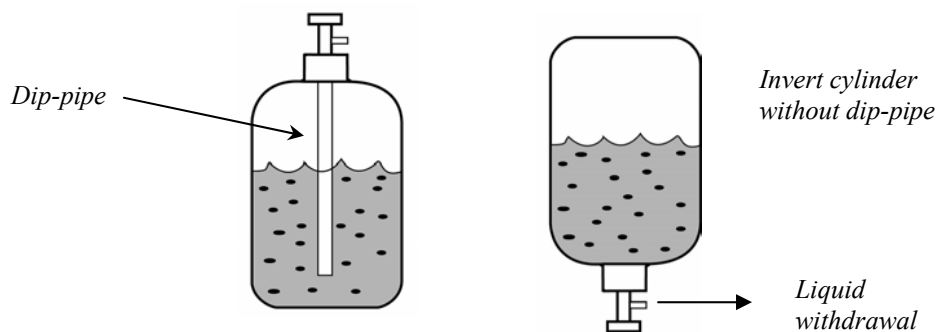

- g) When servicing a leak, the top-up method, commonly practiced for R22 system, is not recommended for R407C system. Unlike R22 where the refrigerant is of a single component, the composition of R407C, which is made up of three different components, may have changed during the leak. Consequently, a top-up may not ensure that the R407C in the system is of original composition. This composition shift may adversely affect the system performance. It is recommended that the system should be evacuated thoroughly before recharging with R407C.

Installation

M4AC / MAC080 / 100 / 120 / 150 C/CR

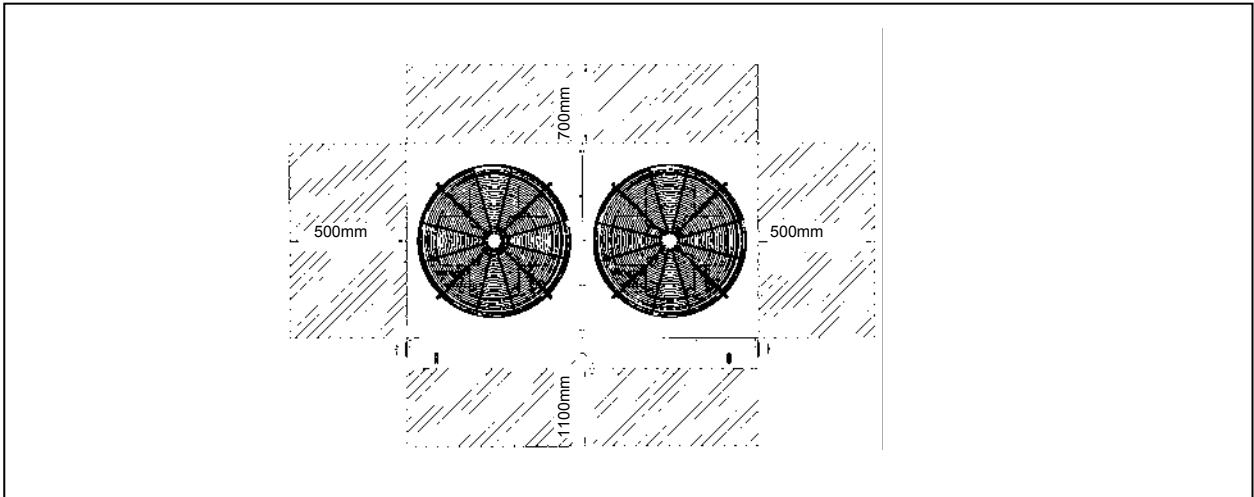
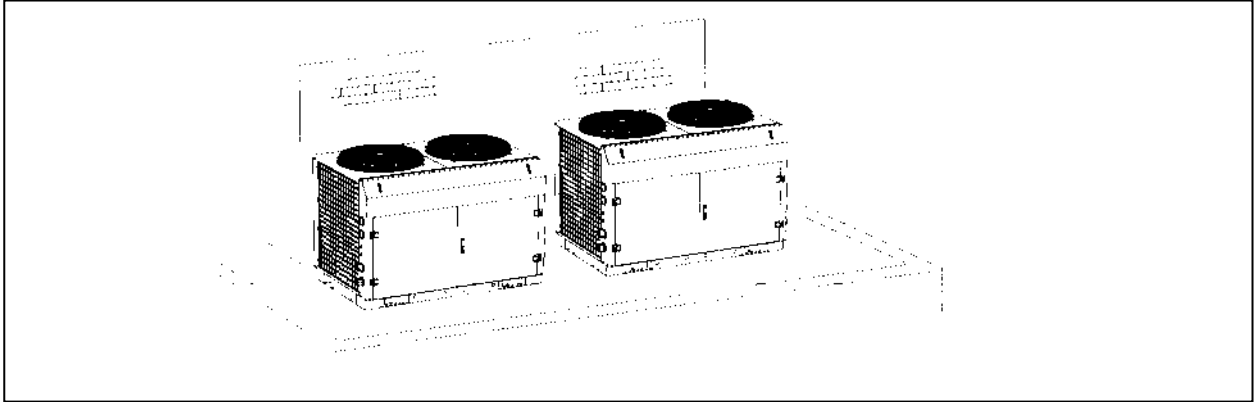

Safety Precautions

Before installing the air conditioner unit, please read the following safety precautions carefully



Warning

- Installation and maintenance should be performed by qualified persons who are familiar with local code and regulation, and experienced with this type of appliance.
- All field wiring must be installed in accordance with the national wiring regulation.
- Ensure that the rated voltage of the unit corresponds to that of the name plate before commencing wiring work according to the wiring diagram.
- The unit must be GROUNDED to prevent possible hazards due to insulation failure.
- All electrical wiring must not touch the refrigerant piping, compressor or any moving parts of the fan motors.
- Confirm that the unit has been switched OFF before installing or servicing the unit.
- Do not touch the compressor or refrigerant piping without wearing gloves.

IMPORTANT

DO NOT INSTALL OR USE THE AIR CONDITIONER UNIT IN A LAUNDRY ROOM.



Caution

Please take note of the following important points when installing.

- **Do not install the unit where leakage of flammable gas may occur.**



If gas leaks and accumulates around the unit, it may cause fire ignition.

- **Ensure that the drainage piping is connected properly.**



If the drainage piping is not connected properly, it may cause water leakage which will dampen the furniture.

- **Do not overcharge the unit.**



This unit is factory pre-charged. Overcharge will cause over-current or damage to the compressor.

- **Ensure that the units panel is closed after service or installation.**



Unsecured panels will cause unit to operate noisily.

Installation Location

- Installation work should be done by the authorized dealer or qualified contractor. Never install the unit yourself.
- Make sure there is sufficient airflow around the unit. The discharged air should be directed outside using a duct should the unit be installed in a plant room.
- Vibration isolator should be provided to reduce the vibration and noise of the unit.
- There should be sufficient space allocated for servicing and maintenance when installing the unit.

Transportation

- The unit should be lifted using a crane. Ensure that the hanger belts are not touching the coil, top panel and front panel (use protective panel) as shown in Figure 1.
- The bolt of the base and channel support can be removed after putting the unit on the fixed location.

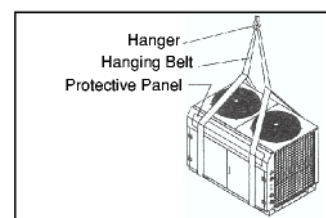
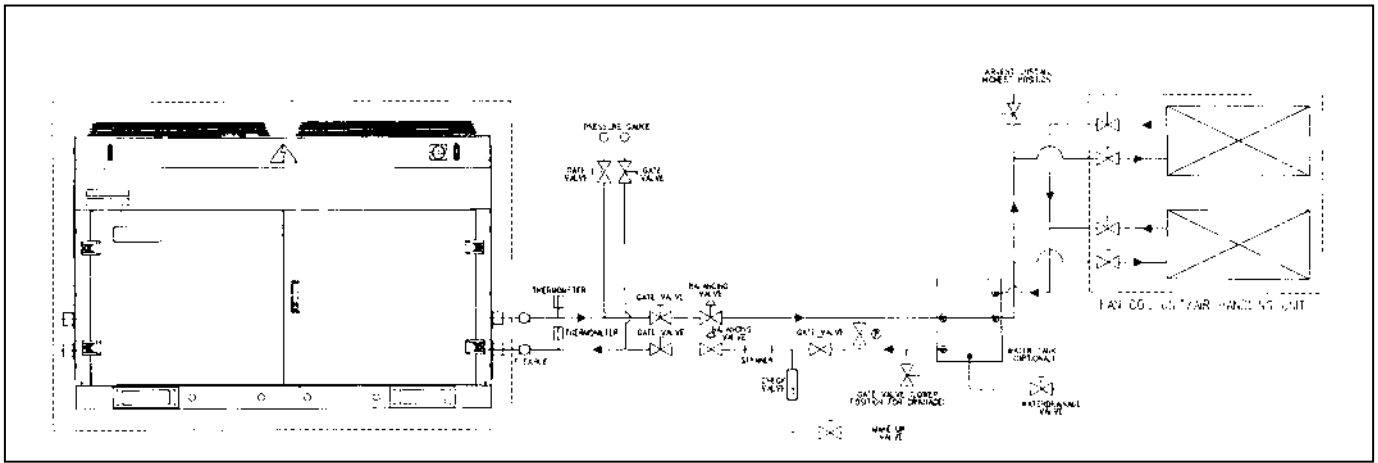

Figure 1

Water Piping and Fitting

- All water pipe must be insulated to prevent capacity losses and condensation.
- Install a 40-60 mesh strainer to ensure water quality is good.
- Water pipe recommended are GI pipe, black steel pipe, steel pipe and copper pipe.
- During installation, the piping of the unit should be clamp before rotating the installation pipe to reduce the moment induce on the unit piping.
- Users are recommended to install the pipe and accessories as shown in Figure 2.
- An air vent must be installed at the highest position, while a drainage plug at the lowest position of the water circuit. After the leak test (0.6MPa), open the air vent to release any air trap in the water circuit.
- Run the clean water through the water inlet and operate the pump to drain out the dirty water. Clean the strainer after running the pump for 30 minutes.



Electrical and Wiring

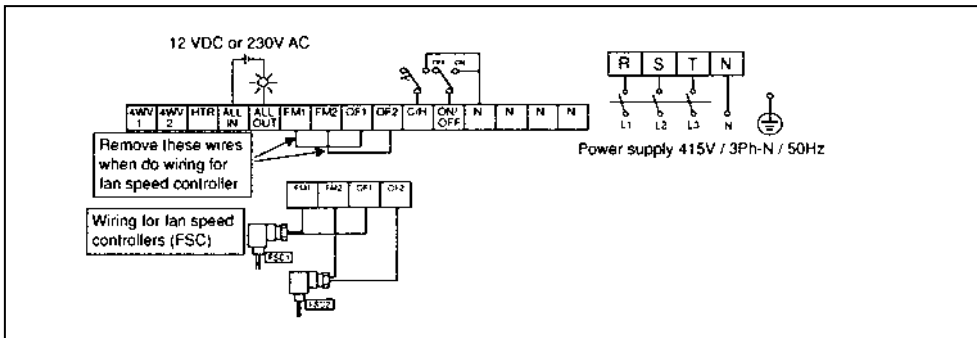

- Refer to the wiring diagram provided on the unit when making electrical wiring.
- Install an isolator (if it is not provided) to prevent electrical shock.
- Do not ground any electrical equipment to the water piping.
- Operation of the mini chiller without any fan speed controller (Field supply) is limited to an ambient temperature of 20°C. With the fan speed controller (Field supply), the unit is able to operate down to -5°C.

Cooling Only Unit

Model		M4AC080C MAC080C	M4AC100C MAC100C	M4AC120C MAC120C	M4AC150C MAC150C
Voltage Range **		380 - 415V /3Ph /50Hz + N + \oplus			
Recommended Fuse *	A	35	40	50	60
Power Supply Cable Size *	mm ²	10		10	
Number of Conductor		5		5	
Interconnection Cable Size *	mm ²	1.5		1.5	

Heat Pump Unit

Model		M4AC080CR MAC080CR	M4AC100CR MAC100CR	M4AC120CR MAC120CR	M4AC150CR MAC150CR
Voltage Range **		380 - 415V /3Ph /50Hz + N + \oplus			
Recommended Fuse *	A	35	40	50	60
Power Supply Cable Size *	mm ²	10		10	
Number of Conductor		5		5	
Interconnection Cable Size *	mm ²	1.5		1.5	

IMPORTANT : * The figures shown in the table are for information purpose only. They should be checked and selected to comply with the local/national codes of regulations. This is also subject to the type of installation and conductors used.

** The appropriate voltage range should be checked with label data on the unit.



WARNING

- All terminals and connection must be tightened.
- Avoid any wires from touching the refrigerant pipe. Apply insulation if necessary.
- Avoid any wires from touching the moving components such as, fan motor, pump & compressor.

Water Piping System Setup

- Fill up the water circuit after connecting all the pipes and equipment. Perform leak checks for all connections and joints. Do not start the unit when the system is leaking.
- To optimize the capacity of the system, ensure that the system is free of air bubbles. The air trapped in the system would make the system unbalanced.
- Ensure that the water tank (optional) is not full. This is to ensure optimal performance of the mini chiller. If the pressure is too high, release the air trapped from the auto air vent (on the tank) and manual air vent (installed on the water system).

Refrigerant Circuit

- All mini chillers units are pre-charged with R22 or R407C refrigerant. The only piping that needs to be done is the water piping from mini chiller (outdoor) to the fan coil unit (indoor).

Safety and Caution

It is advisable to read through all the safety precautions before installing and commissioning of the unit.

- Contact your dealer for installation, reinstallation or dismantling of unit. Improper handling of unit could result in leaks, electrical shock or unit malfunction.
- Use the controller handset to switch on/off the unit. Do not plug off the main power supply directly, it would cause the unit to breakdown.
- Improper connections and fastening could cause electric shock, short circuit and fire.
- Do not introduce foreign objects such as fingers, sticks etc. into the air inlet and outlet.
- Do not spray any chemical agents or flammable agents to the unit. It would cause fire or explosion.
- Do not climb or place objects on top of the mini chiller.
- Do not operate the chiller with wet hands. It would result in electric shock.
- Do not use fuse of different amperage than stated. Using wire, etc. to replace a fuse could cause equipment damage or fire.
- Provide proper grounding for the mini chiller. Do not connect the ground wire to gas piping, water piping, lighting rods or telephone ground wire. Improper grounding could cause electrical shock.
- Do not attempt to do any service or maintenance when unit is operating.
- Do not change the settings of the safety devices.
- Do not consume the chilled water in the unit.
- Do not allow water to remain in the water pipes if the unit is not operating for a long period. Water must be drained out if the unit is not running during winter. Failing to do so would cause the pipe to crack.
- Do not touch the aluminum fin coil. It would damage the coil or cause injury.



Caution

- R407C must be charged as liquid. Usually R407C cylinder is equipped with a dip-pipe for liquid withdrawal. If there is no dip-pipe, the cylinder should be inverted so as to withdraw liquid R407C from the valve.
- Do not top-up when servicing leak, as this will reduce the unit performance. Vacuum the unit thoroughly and then charge the unit with fresh R407C according to the amount recommended in the specification.

Control Operation Guide

The unit is equipped with a microprocessor controller board. The microprocessor controller is provided to give temperature control for the system by accurately measuring the ambient temperature, and controlling the water entering and water leaving temperature. The temperature setting in the unit is preset in the factory. It is not recommended to change the setting unless necessary. A wired controller handset is connected to the microprocessor board. Every parameter setting and reading can be observed from the LCD of the handset.

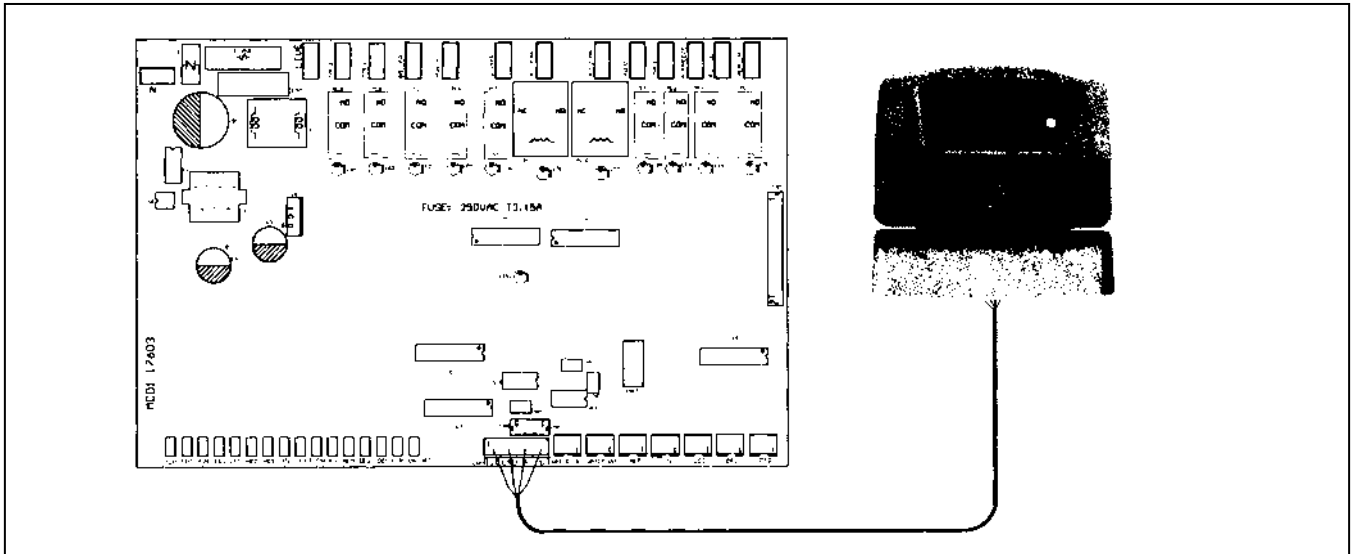

1. Handset location
The handset is located on a metal bracket behind the right door panel.
2. LED Display (microprocessor board)
The keypad LED will light up when the unit is powered up.
The LCD will light up when the unit is turned on.
3. LCD display (controller handset)
During normal operations, the LCD can display the entering water temperature, the leaving water temperature, the entering water setpoint temperature, compressor on or off status and outdoor air temperature. When malfunctioning occurred, the LCD would blink. The display would show the faulty parameter and the date and time of the occurrence.
4. Controller functioning specification
There is a 3 minute delay for the compressor and fan motor to restart (default setting). During defrosting, fan motor is not running.

Servicing and Maintenance

Servicing

Servicing or maintenance of these unit must be carried out by experienced personnel with specific training in refrigeration. Repeated check the safety devices and continuous cycling of control components must be analyzed and corrected before being reset.

The simple design of the refrigeration circuit totally eliminates potential problems during normal unit operation. No maintenance work is needed on the refrigeration circuit as long as the unit is operating normally.

Ease of maintenance has been taken into consideration during the design stage such that the unit is easily accessible for servicing and maintenance. By accessing from the front panel of the unit, servicing and maintenance operation can be done easily. The electrical components are especially easy to access since it is located in the terminal box on top of the front panel.

Under normal circumstances, these chiller require only a check and cleaning of air intake through the coil surface only. These can be done monthly or quarterly depending on the surrounding where the units are installed.

When the surrounding is very oily or dusty, then the coils must be regularly cleaned by a qualified air conditioner service technician to ensure sufficient cooling capacity and efficient unit operation. The normal life span might be shortened if no proper service is provided.

Maintenance

For consistent performance and durability, always conduct proper and regular maintenance to the unit.

For prolong period of operation time, the heat exchanger will become dirty impairing its effectiveness and reducing the performance of the units. Consult your local dealer about the cleaning of the heat exchanger.

No major maintenance or servicing needed for the internal water circuit in the unit except the water pump failure. It is advised that regular check on the filter to be conducted and change the water filter if the filter is dirty or choked.

Always check the water level in the system, in order to protect the moving components in the hydraulic kit from over heating and excessive wear.

Troubleshooting

When any malfunction is occurred, immediately switch off the power supply to the unit, and contact the local dealer, if necessary. Some simple troubleshooting tips are given below:

SYMPTOMS	POSSIBLE CAUSES	REMEDIAL ACTION
1. Compressor does not start.	<ul style="list-style-type: none"> No power supply. Fuses blown or automatic circuit break-down open. Defective contactor or coil. Unit is stopped because safety device has tripped. Loose wires. Compressor faulty 	<ul style="list-style-type: none"> Check power supply. Look for short circuit or grounded wires In motor windings. Replace fuses and reset circuit breakers when the fault has been corrected. Check tightness and soundness of all electrical connections. Repair or replace. Determine the type of safety shutdown and correct the default before the unit is restarted. Check wire connections and tighten terminal screws. Contact local dealer.
2. Fan does not work	<ul style="list-style-type: none"> No power supply. Fan motor faulty. 	<ul style="list-style-type: none"> Check power supply. Contact local dealer.
3. Unit does work, but insufficient cooling.	<ul style="list-style-type: none"> Thermostat setting too high. Condenser coil dirty. Obstacle blocking air inlet or outlet of the unit. Insufficient refrigerant in the system. Improper water flow rate. Water in the system is contaminated. 	<ul style="list-style-type: none"> Reset thermostat. Contact local dealer. Remove the obstacle. Contact local dealer. Contact local dealer. Contact local dealer.

Phase Protector (Optional)

The unit with Scroll Compressor can only rotate in one direction. For this reason, a protective device (phase protector) is fitted to prevent incorrect wiring of the electrical phases. When the three phases are not connected correctly, the phase protector operates, and the unit will not start. This device is located in the control box of the outdoor unit.

The following table shows the LED indicator light for phase protector under normal operation and fault conditions.

Description	LED				Actions
	PW (Red)	P_R (Yellow)	P_S (Yellow)	P_T (Yellow)	
Normal operation	○	●	●	●	-
Reverse phase	◐	◐	◐	◐	Switch off the unit. Check the 3 phase wiring.
T phase missing	◐	●	●	◐	Switch off the unit. Check the 3 phase wiring.
S phase missing	◐	●	◐	●	Switch off the unit. Check the 3 phase wiring.
R phase missing	●	●	●	●	Switch off the unit. Check the 3 phase wiring.
S & T phase missing ⁺	◐	●	◐	◐	Switch off the unit. Check the 3 phase wiring.
Overload ⁺	◐	●	●	●	High discharge temperature. Check the refrigerant system.
Sensor missing ⁺	◐	○	○	○	Switch off the unit. Plug in sensor.

○: On ●: Off ◐: Fast Blink

Notes: 1. "+" indicates additional functions for PP01 phase protector.
2. When R phase missing, no LED or buzzer will indicate the error, but relay 71 and 81 will out off.

Schematic Diagram

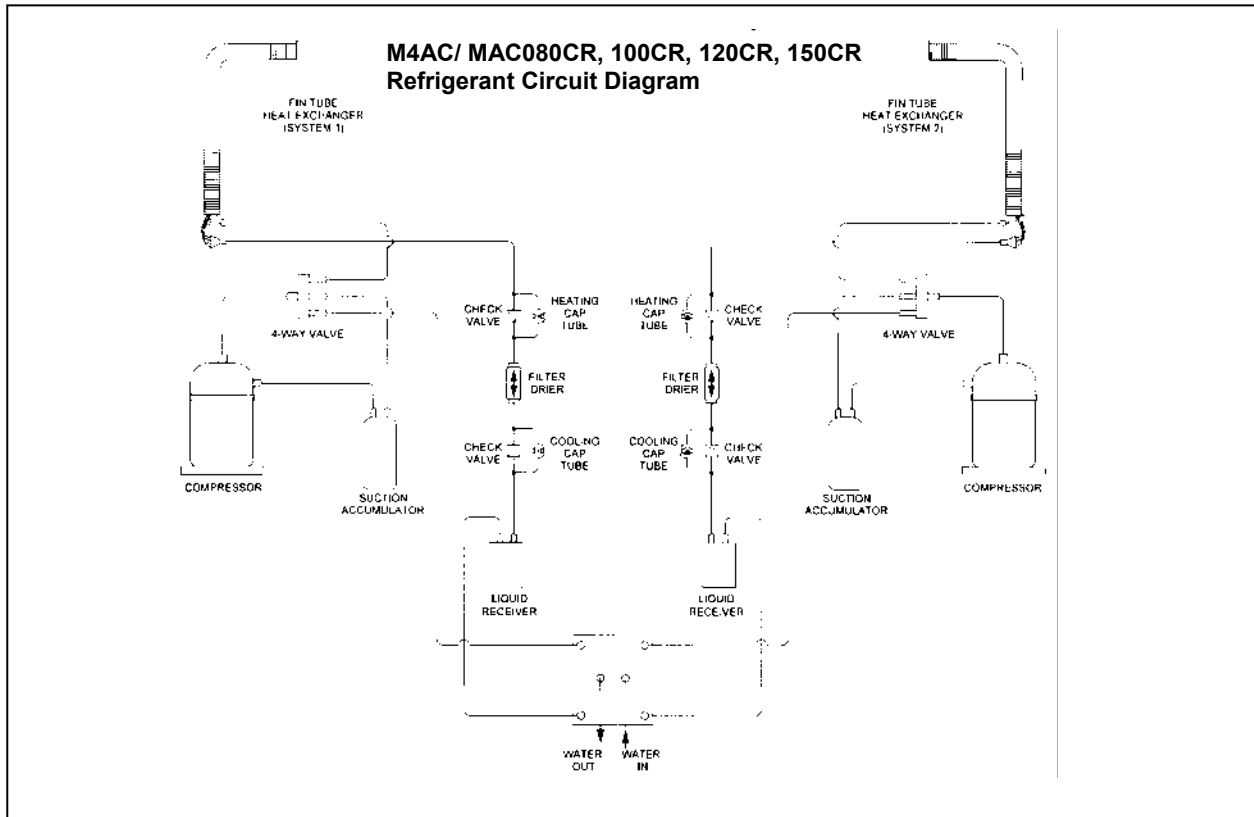
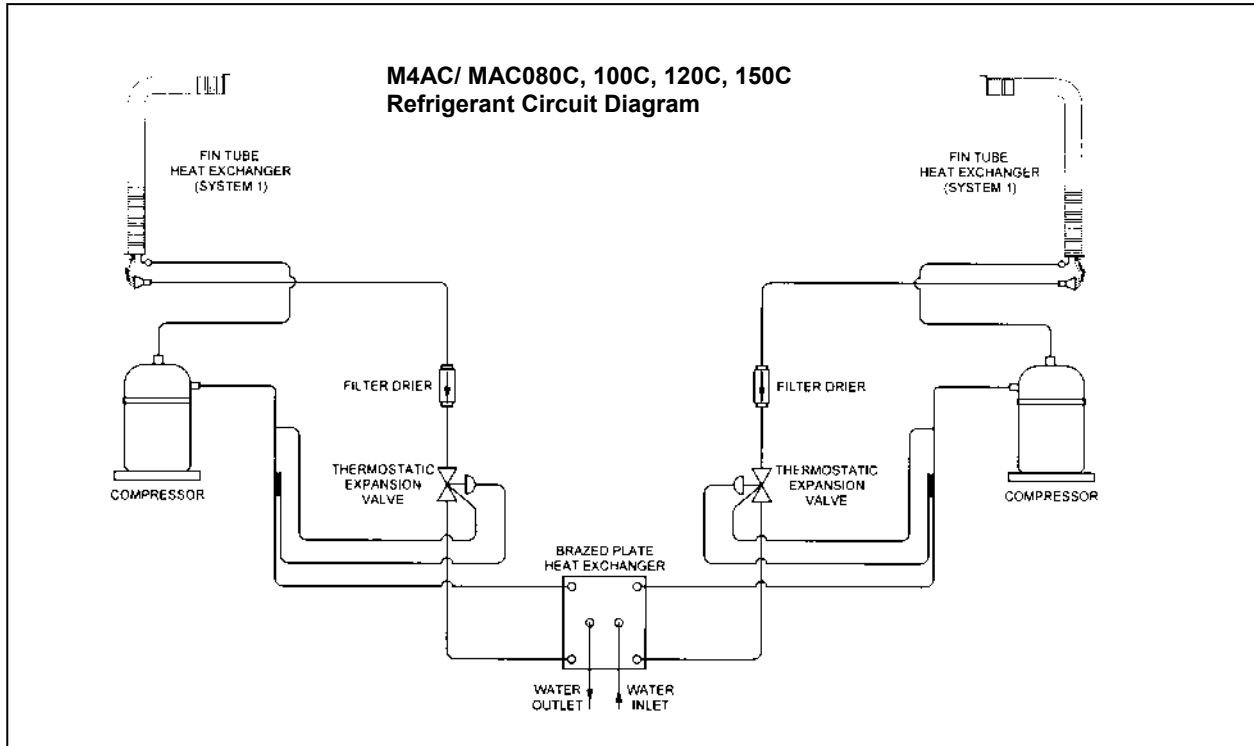

Part Lists and Exploded View

M4AC / MAC080 / 100C/CR

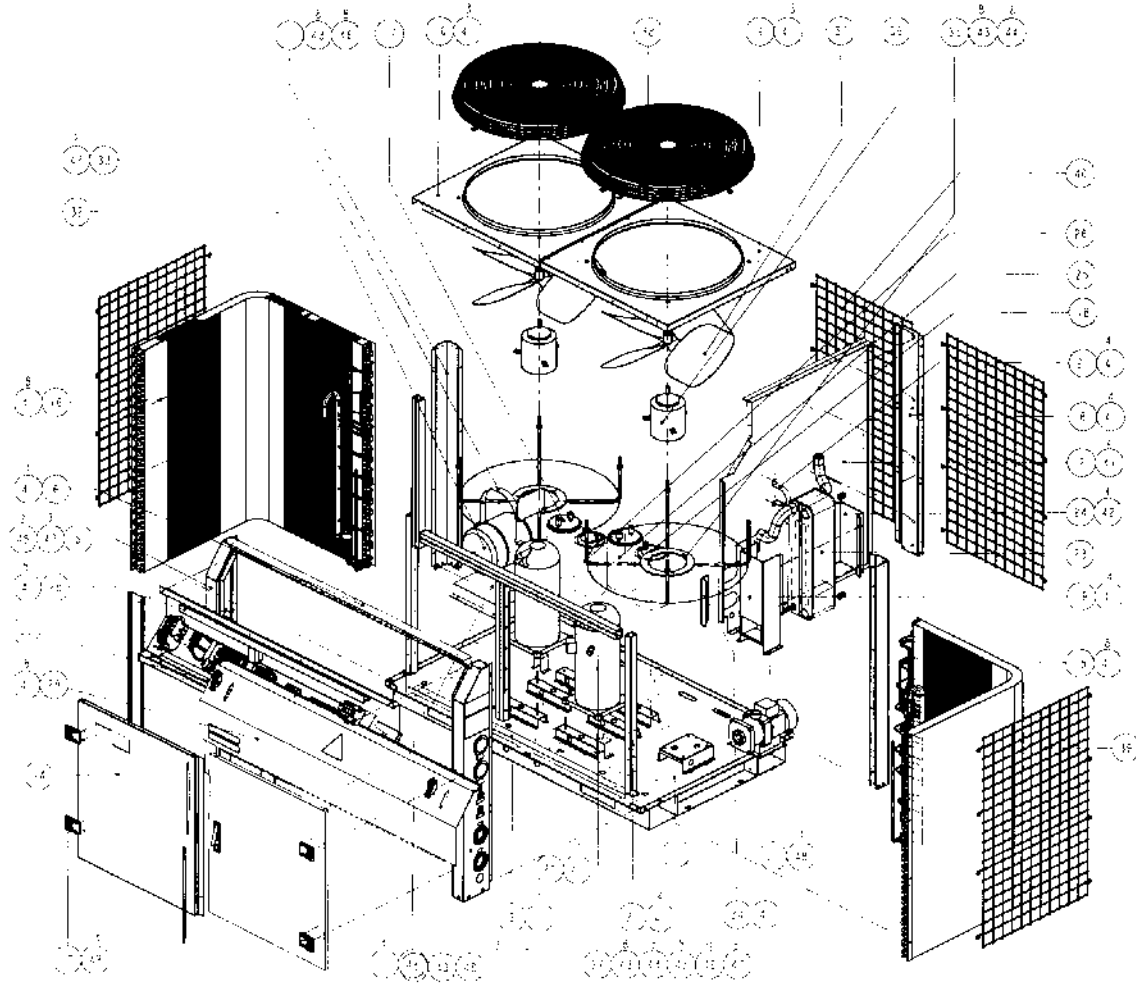

1	ASSY, PANEL BASE MAIN	19	BRACKET, BPHE	37	FAN BLADE 24"
2	ASSY, INS. PARTITION PANEL	20	SUPPORT, TUBE	38	FAN, GUARD 24"
3	SUPPORT, FLUTTED WIRE	21	CLIP, FILTER	39	COIL GUARD, LEFT/RIGHT
4	ASSY, RIGHT PANEL	22	ASSY, COMPRESSOR	40	COIL GUARD, BACK
5	ASSY, LEFT PANEL	23	ASSY, BPHE		PVC, TRUNKING (33.0x45.0x710.0)
6	PANEL, SUPPORT FRONT	24	PANEL, BPHE CLAMP		PVC, TRUNKING (33.0x45.0x1154.0)
7	STRUCTURE, BACK L/R	25	INS, ACCUMULATOR BODY		PANEL, PARTITION COVER
8	PANEL, COIL SUPPORT	26	INS, LIQUID RECEIVER	41	SCREW, TRUSS PHILIP HEAD
9	PANEL, ORIFICE RIGHT	27	PANEL, TERMINAL BOX SUPPORT	42	SCREW, TRUSS PHILIP HEAD
10	PANEL, ORIFICE LEFT	28	ASSY., TER. BOX MAIN	43	WASHER, SPRING
11	SUPPORT, EXPANSION TANK	29	ASSY, FRONT PANEL	44	NUT, HEXAGON
12	HINGE, DOOR	30	ASSY, PANEL HOOK	45	WASHER, FLAT
13	ASSY, DOOR PANEL RIGHT MAIN	31	PUMP, WATER	46	SPACER
14	ASSY, DOOR PANEL LEFT MAIN	32	EXPANSION TANK	47	RUBBER, GROMMET
15	ASSY, COIL RIGHT	33	CLAMP, EXPANSION TANK	48	HEX, BOLT
16	ASSY, COIL LEFT	34	PLATE, PARTITION		
17	ACCUMULATOR	35	BRACKET, MOTOR		
18	LIQUID RECEIVER	36	MOTOR		

M4AC/ MAC120/ 150C/CR

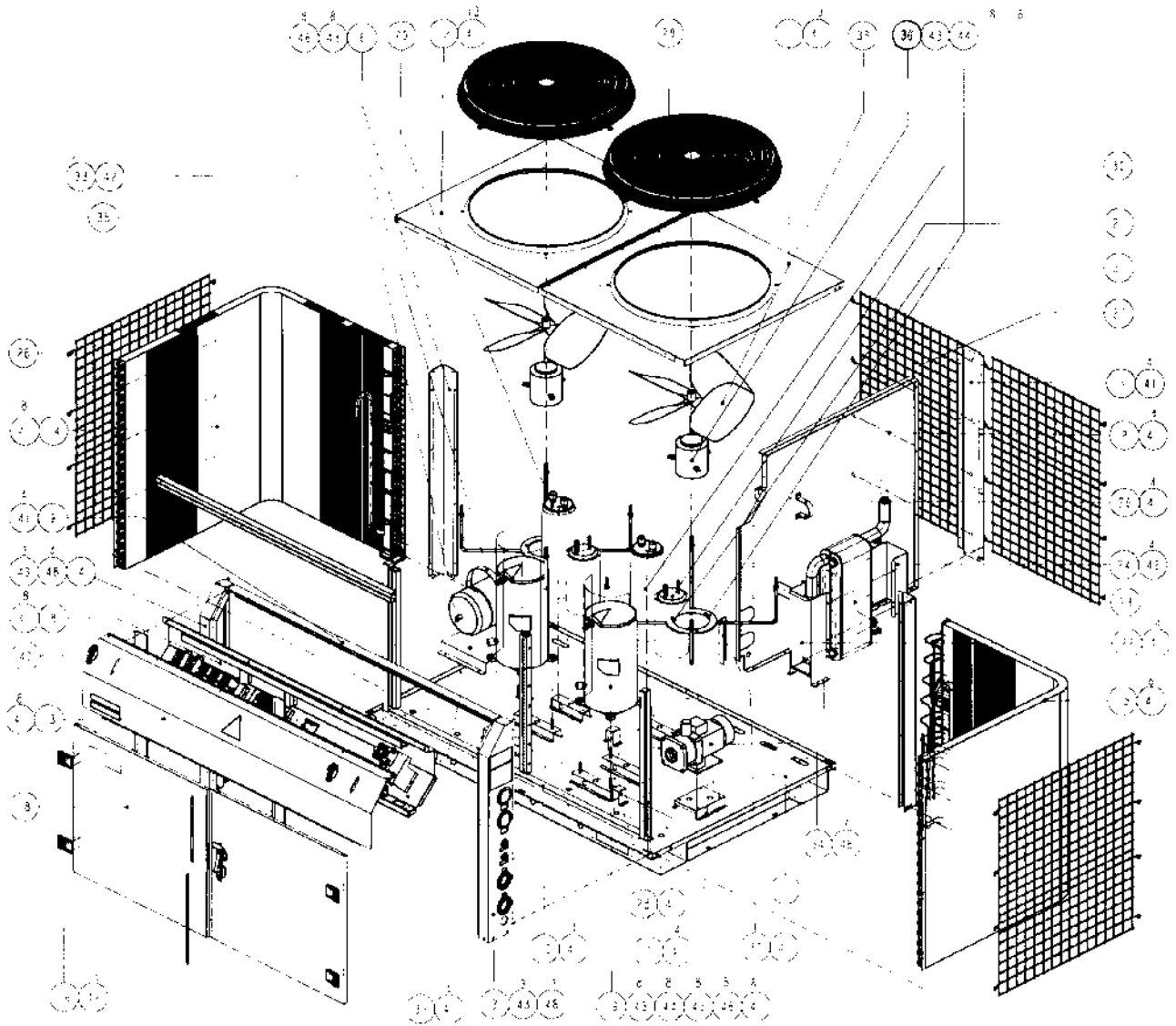

1	ASSY. PANEL BASE MAIN	17	ASSY, DOOR PANEL RIGHT MAIN	33	CLAMP, EXPANSION TANK
2	ASSY, INS. PARTITION PANEL	18	ASSY, DOOR PANEL LEFT MAIN	34	PUMP, WATER
3	ASSY, RIGHT PANEL	19	ASSY, COMPRESSOR (ZR94KC-TFD)	35	EXPANSION TANK
4	ASSY, LEFT PANEL	20	ACCUMULATOR	36	BRACKET, MOTOR
5	PANEL, COIL SUPPORT	21	LIQUID RECEIVER	37	MOTOR
6	STRUCTURE, BACK L/R	22	BRACKET, BPHE	38	FAN BLADE 24"
7	PANEL, TERMINAL BOX SUPPORT	23	ASSY, BPHE	39	PLATE, PARTITION
8	ASSY., TER, BOX MAIN	24	PANEL, BPHE CLAMP	40	ASSY, PANEL HOOK
9	PANEL, SUPPORT FRONT	25	SUPPORT, TUBE		PVC, TRUNKING (3'3.0x45.OM710.0)
10	SUPPORT, WIRE BOARD	26	CLIP, FILTER		PVC, TRUNKING (33.0x45.OM1481.0)
11	PANEL, RIGHT ORIFICE	27	COIL GUARD, BACK	41	SCREW, TRUSS PHILIP HEAD
12	PANEL, LEFT ORIFICE	28	COIL GUARD, LEFT/RIGHT	42	SCREW, TRUSS PHILIP HEAD
13	ASSY, INS. FRONT PANEL	29	FAN, GUARD 26"	43	WASHER, SPRING
14	ASSY, COIL LEFT	30	INS, ACCUMULATOR BODY	44	NUT, HEXAGON
15	ASSY, COIL RIGHT	31	INS, LIQUID RECEIVER BODY	45	WASHER, FLAT
16	HINGE, DOOR	32	SUPPORT. EXPANSION TANK	46	SPACER

