

WR 8/10/11/13/14/15/18 P...

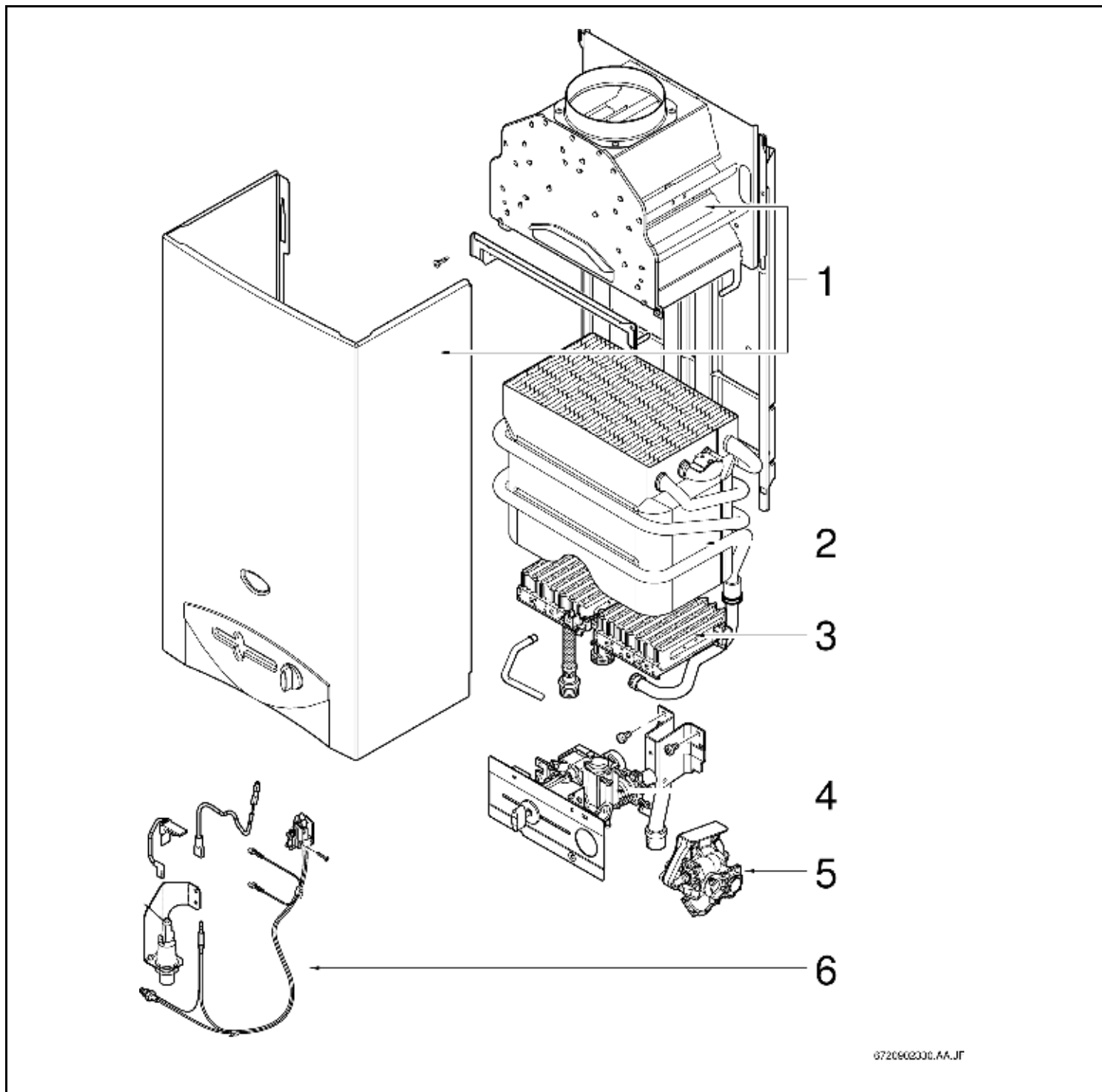

6720609066_AA_JF

[de] Wichtige Hinweise zur Installation/Montage

Die Installation/Montage muss durch eine für die Arbeiten zugelassene Fachkraft unter Beachtung der geltenden Vorschriften erfolgen.

[en] Important notes on installation/assembly

The installation/assembly must be carried out by a professional who is authorised to do the work, and with due regard to the relevant regulations.

[fr] Instructions importantes pour l'installation/le montage

L'installation/le montage doit être effectué(e) par un spécialiste qualifié pour les opérations concernées et dans le respect des prescriptions applicables.

[bg] Важни указания във връзка с инсталацията/монтажа

Инсталацията/монтажът трябва да се извършва от лицензиран за работите специалист в съответствие с приложимите разпоредби.

[cs] Důležité pokyny k instalaci/montáži

Instalaci/montáž musí při dodržení platných předpisů provést odborný pracovník s příslušným oprávněním pro tyto práce.

[da] Vigtige anvisninger til installationen/monteringen

Installationen/monteringen skal foretages af en godkendt installatør under overholdelse af de gældende forskrifter.

[el] Σημαντικές υποδείξεις για την εγκατάσταση/συναρμολόγηση

Η εγκατάσταση/συναρμολόγηση πρέπει να πραγματοποιείται από εξουσιοδοτημένο για τις εργασίες αυτές τεχνικό προσωπικό, το οποίο θα πρέπει να φροντίζει ώστε να τηρούνται οι ισχύουσες διατάξεις.

[es] Indicaciones importantes para instalación/montaje

La instalación/el montaje lo debe realizar personal especializado autorizado para los trabajos, respetando las prescripciones vigentes.

[et] Olulised juhised paigaldamiseks/montaažiks

Paigaldamist/montaaži tohib läbi viia selleks volitusi omav spetsialist, arvestades kehtivaid nõudeid.

[fi] Belangrijke aanwijzingen betreffende de installatie/montage

De installatie/montage moet worden uitgevoerd door een voor de werkzaamheden geautoriseerde installateur. Hij moet rekening houden met de geldende voorschriften.

[fi] Tärkeitä asennus- ja kokoonpano-ohjeita

Näihin töihin hyväksytyn ammattiasentajan pitää suorittaa asennus- ja kokoonpanotyöt voimassa olevien määräysten mukaisesti.

[hu] Fontos tudnivalók az installáláshoz/szereléshez

Az installálás/szerelést egy, a munkákra felhatalmazott szakembernek kell végeznie, az érvényes előírások figyelembevételével.

[it] Avvertenze importanti per l'installazione/il montaggio

L'installazione/il montaggio deve aver luogo ad opera di una ditta specializzata ed autorizzata in osservanza delle disposizioni vigenti.

[he] מנעונים חשובים לביצוע עבודות התקנה/הרכבה

עבודות התקנה/הרכבה חייבות להיעשות על ידי חברה מוסמכת ומאושרת, תוך שמירה על כללי הבטיחות וההגנה הנדרשים.

[lt] Svarbios instaliavimo ir (arba) montavimo nuorodos

Instaliuoti ir montuoti, laikantis galiojančių taisyklių, leidžiama kvalifikuotiems specialistams, kurie buvo įgalioti šioms darbams atlikti.

[lv] Svarīgi norādījumi par iekārtas uzstādīšanu / montāžu

Iekārtas uzstādīšanu/montāžu ir jāveic specializētam sertificētam speciālistam, ievērojot spēkā esošos noteikumus.

[nl] Belangrijke aanwijzingen betreffende de installatie/montage

De installatie/montage moet worden uitgevoerd door een voor de werkzaamheden geautoriseerde installateur rekening houdend met de geldende voorschriften.

[no] Viktig informasjon om installasjon/montering

Installasjonen/monteringen skal gjennomføres av autoriserte installatører, og gjeldende forskrifter skal følges.

[pl] Ważne wskazówki dotyczące instalacji/montażu

Instalacja/montaż muszą być wykonane przez uprawnionego do tego rodzaju prac specjalistę przy zachowaniu obowiązujących przepisów.

[pt] Indicações importantes relativas à instalação/montagem

A instalação/montagem deve ser efetuada por um técnico especializado com qualificações para estes trabalhos, tendo em atenção os regulamentos em vigor.

[ro] Indicații importante privind instalarea/montajul

Instalarea/montajul trebuie realizate de către un specialist autorizat pentru lucrările respective, respectându-se prescripțiile valabile.

[ru] Важные указания по подключению/монтажу

Подключение/монтаж должны выполнять специалисты, имеющие допуск к выполнению таких работ, при соблюдении действующих норм и правил.

[sk] Dôležité pokyny týkajúce sa inštalácie/montáže

Inštaláciu/montáž musí realizovať odborník s oprávnením na výkon týchto prác, pričom musí dodržiavať platné predpisy.

[sl] Pomembni napotki za namestitvev/montažo

Namestitvev/montažo mora izvesti strokovnjak, pristojen za tovrstna dela, ob upošte vanju veljavnih predpisov.

[sr] Važna uputstva za ugradnju i montažu

Ugradnju i montažu moraju da obave samo stručna lica ovlašćena za izvođenje takvih radova koja će poštovati važeće propise.

[sv] Viktiga anvisningar för installation/montering

Installationen/monteringen måste utföras av en behörig och fackkunnig person enligt gällande föreskrifter.

[tr] Kurulum/Montaj ile ilgili önemli uyarılar

Kurulum/Montaj çalışmaları sadece yetkili bayiler tarafından aşağıda belirtilen talimatlar dikkate alınarak yapılmalıdır.

[uk] Важливі вказівки щодо установки/монтажу

Установку/монтаж мають здійснювати фахівці, що мають дозвіл на проведення цих робіт, із дотримання чинних приписів.

[zh] 安装方面的重要提示

必须由受到许可承担该项工作的专业人员遵照相关法规进行安装。

[ar] ملاحظات هامة للتركيب/التجميع

يجب أن يتم التركيب/التجميع من قبل متخصص مصرح له بالعمل، مع مراعاة اللوائح السارية.

[fa] تذکرات مهم درباره نصب/مونتاژ

نصب/مونتاژ باید توسط فردی حرفه ای که مجاز به انجام این کار است، و همچنین با توجه کامل به مقررات مربوطه انجام شود.

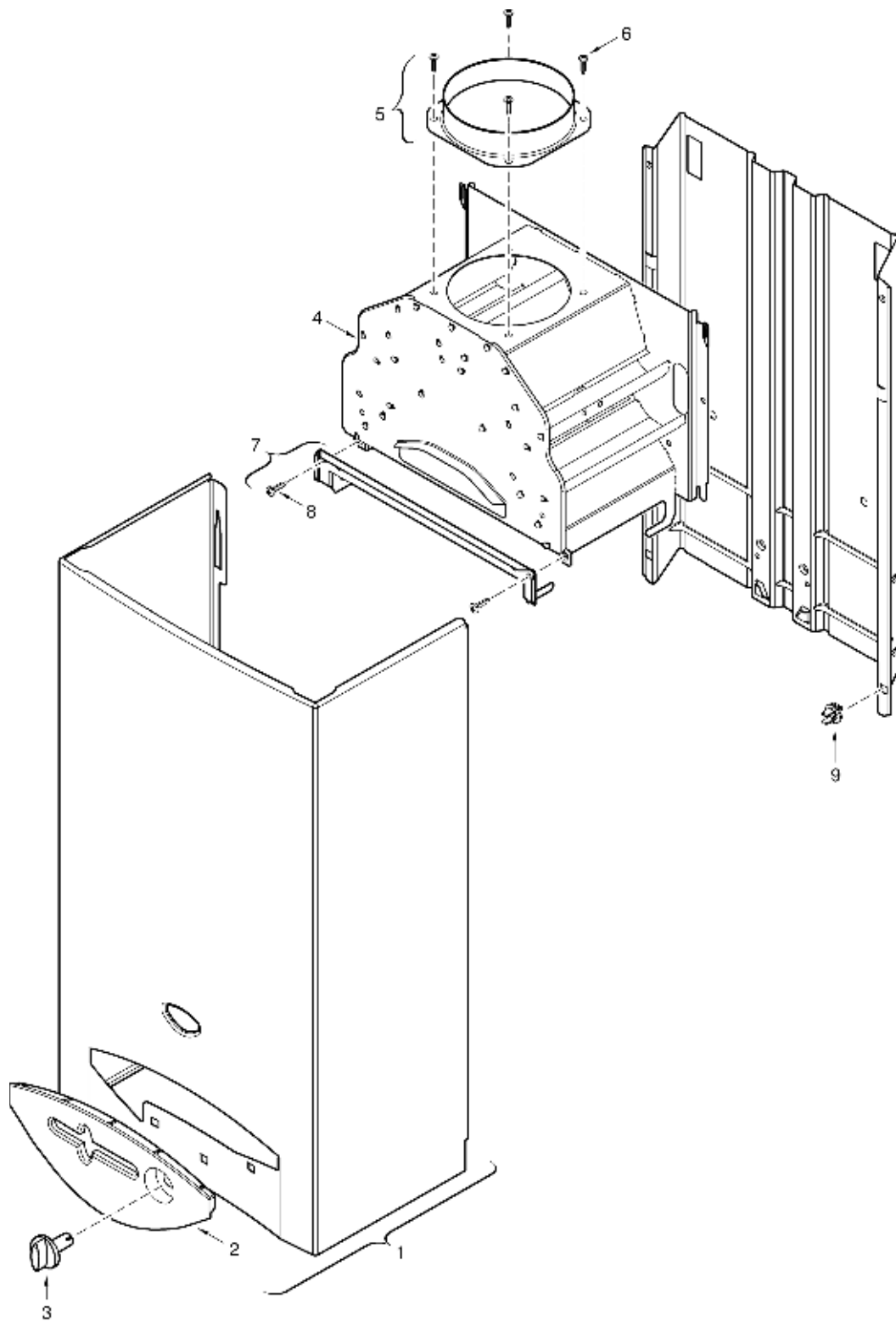

6720609066 AA..JF

1
Sheet metal
Blechteile
Pièces de tôle
Parti di lamiera
Piezas de chapa

WR 8/10/11/13/14/15/18 P...

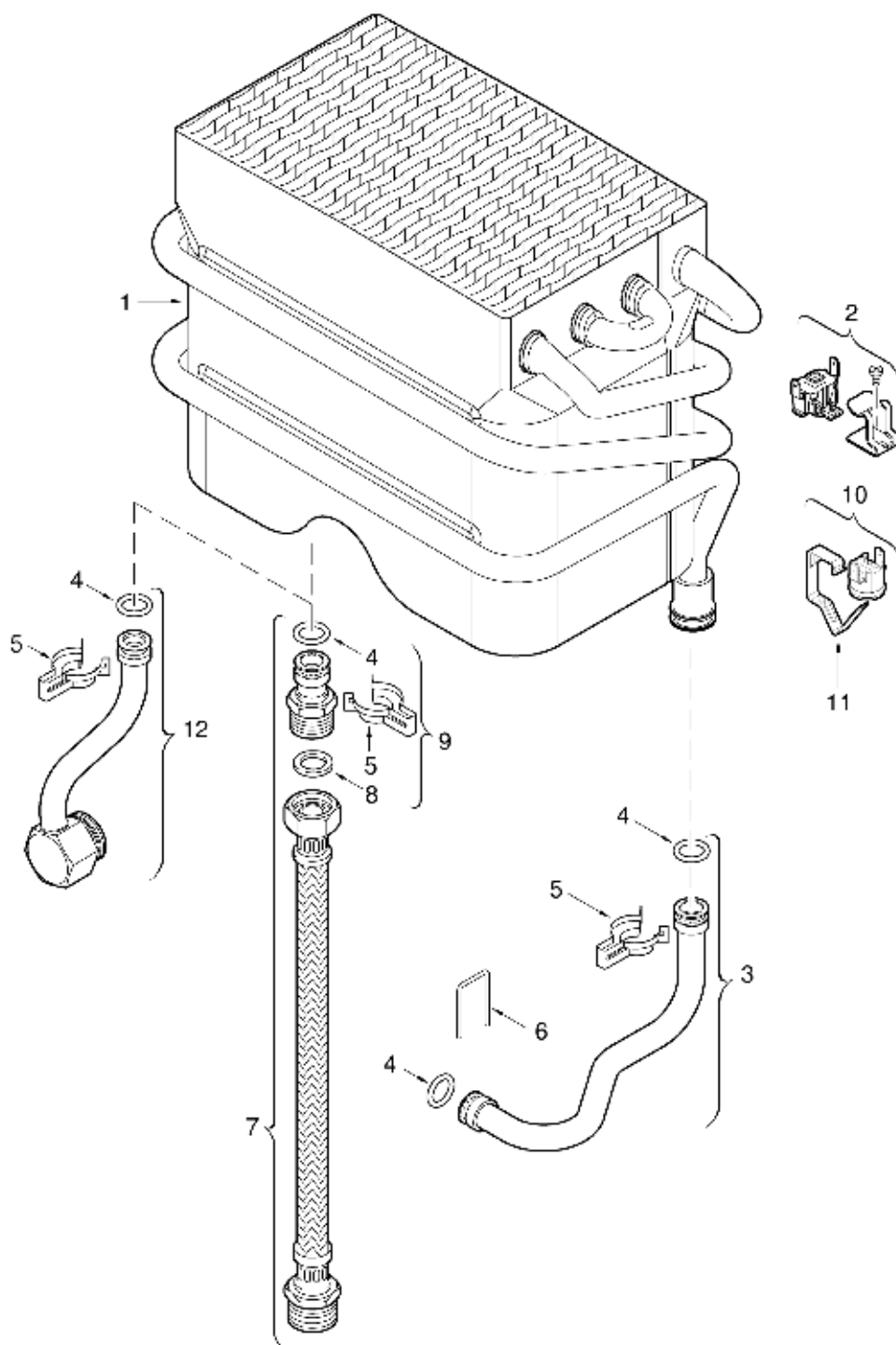

6720902569.AD .JF

2

Heating body
Innenkörper
Corps interieur
Corpo interno
Cuerpo de caldeo

WR 8/10/11/13/14/15/18 P...

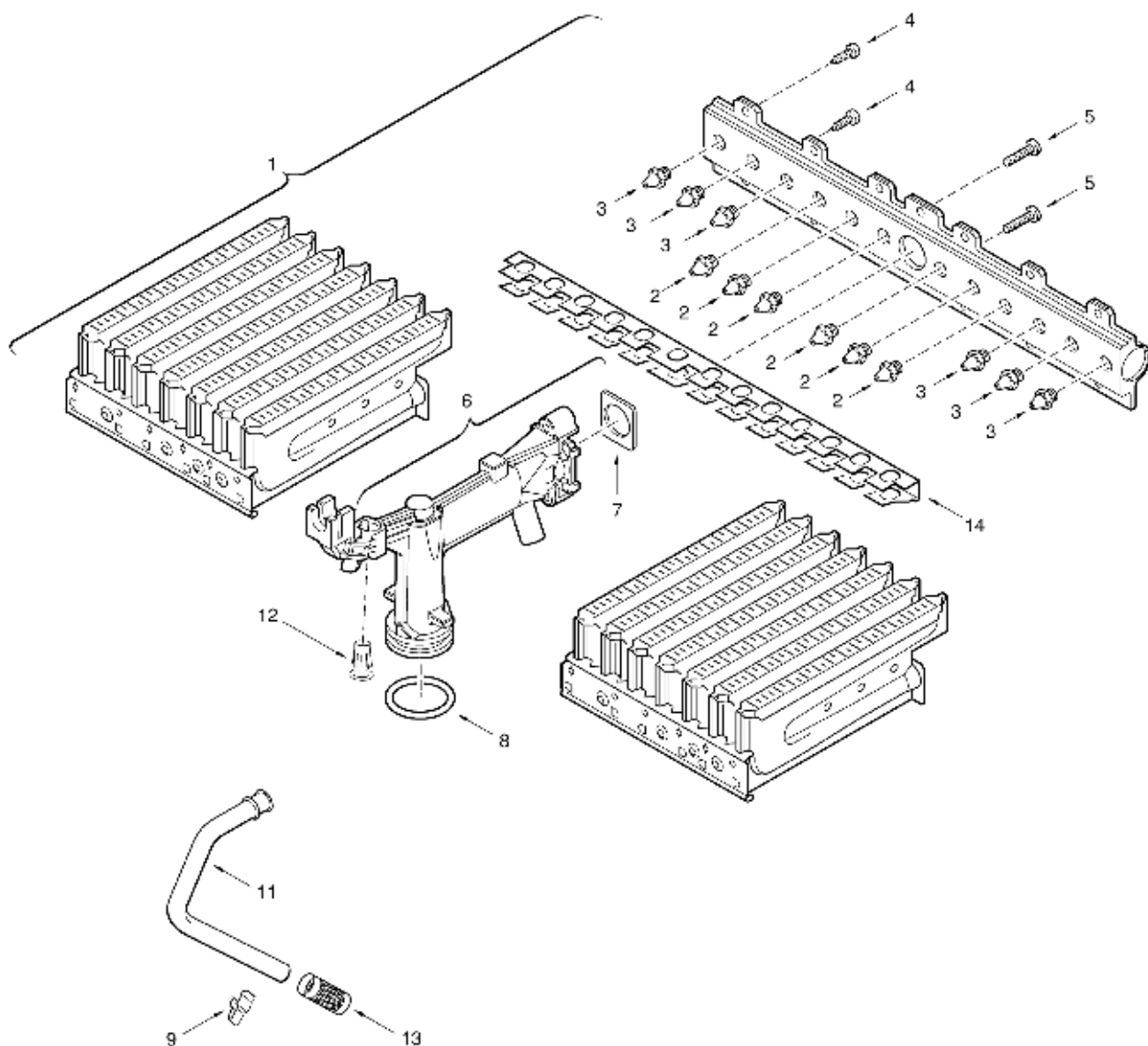

6720902091.AF JF

3

Burner
Brenner
Brûleur
Bruciatore
Quemador

WR 8/10/11/13/14/15/18 P...

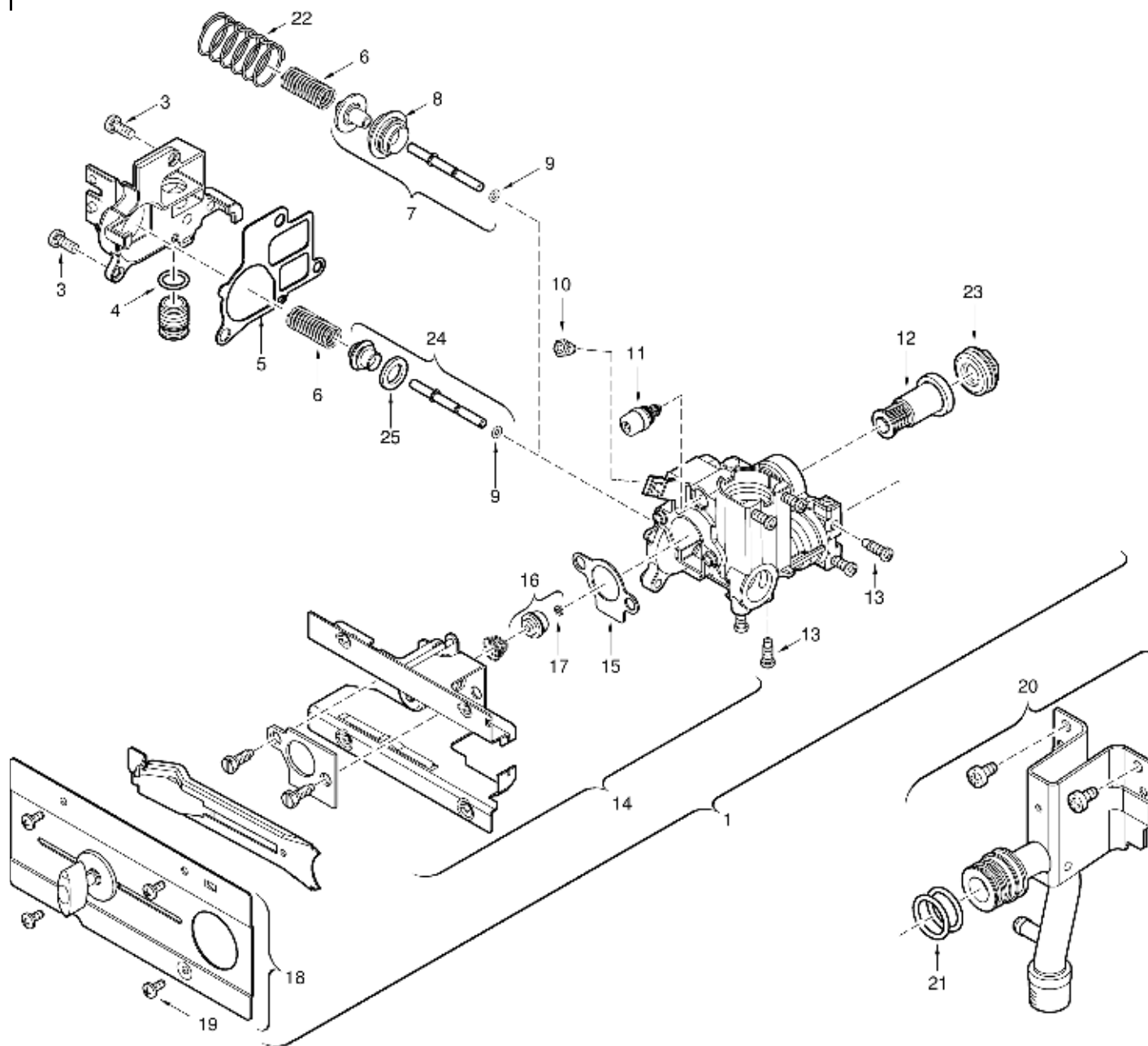

6720607259 AA JF

4

Gas valve
Gasarmatur
Bloc gaz
Gruppo gas
Cuerpo de gas

WR 8/10/11/13/14/15/18 P...

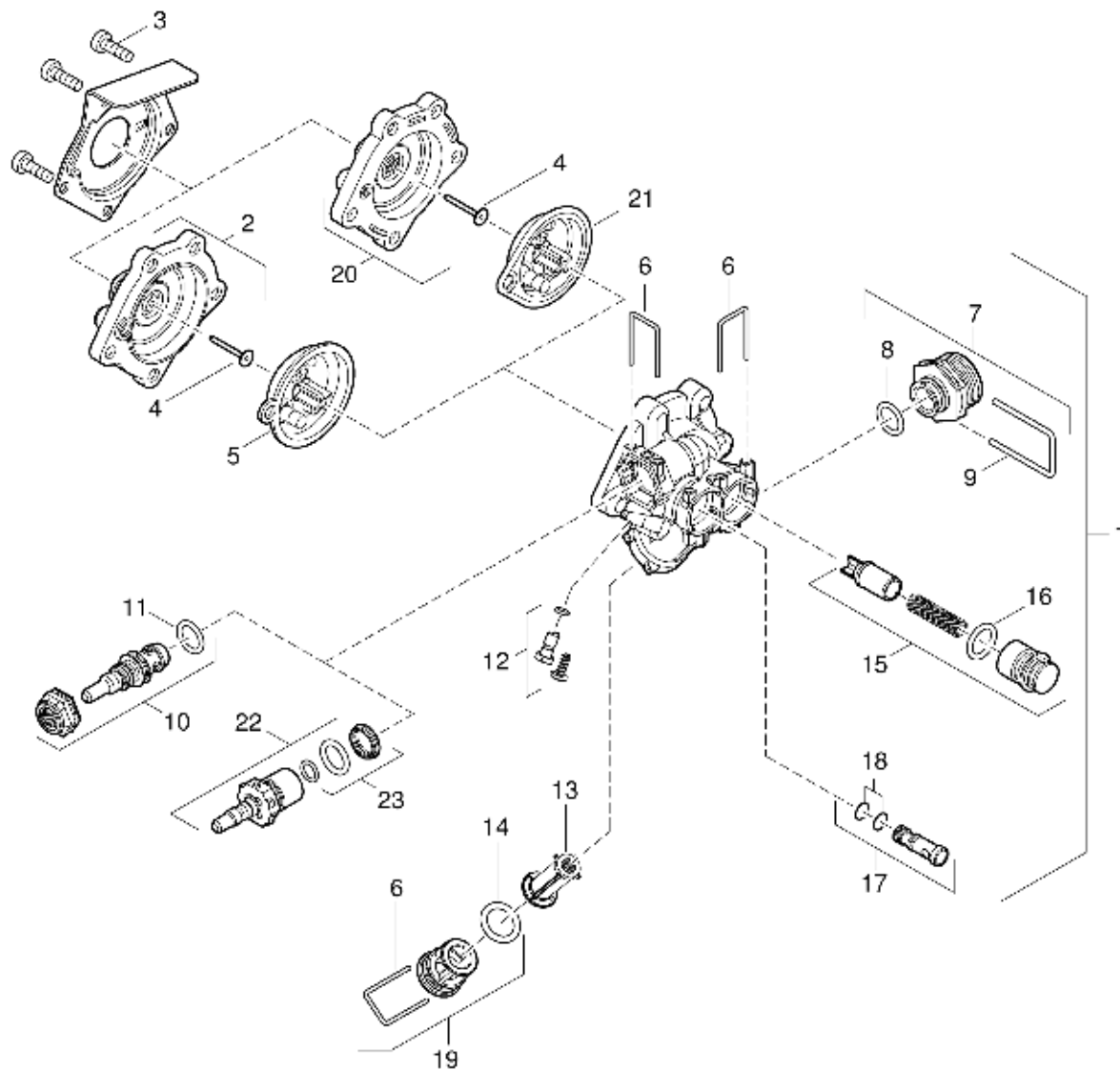

6720902100.AB JF

5

Water valve (plastic)
Wasserarmatur (Kunststoff)
Robinet d'eau (plastique)
Gruppo acqua in plastica
Cuerpo de agua (poliamida)

WR 8/10/11/13/14/15/18 P...

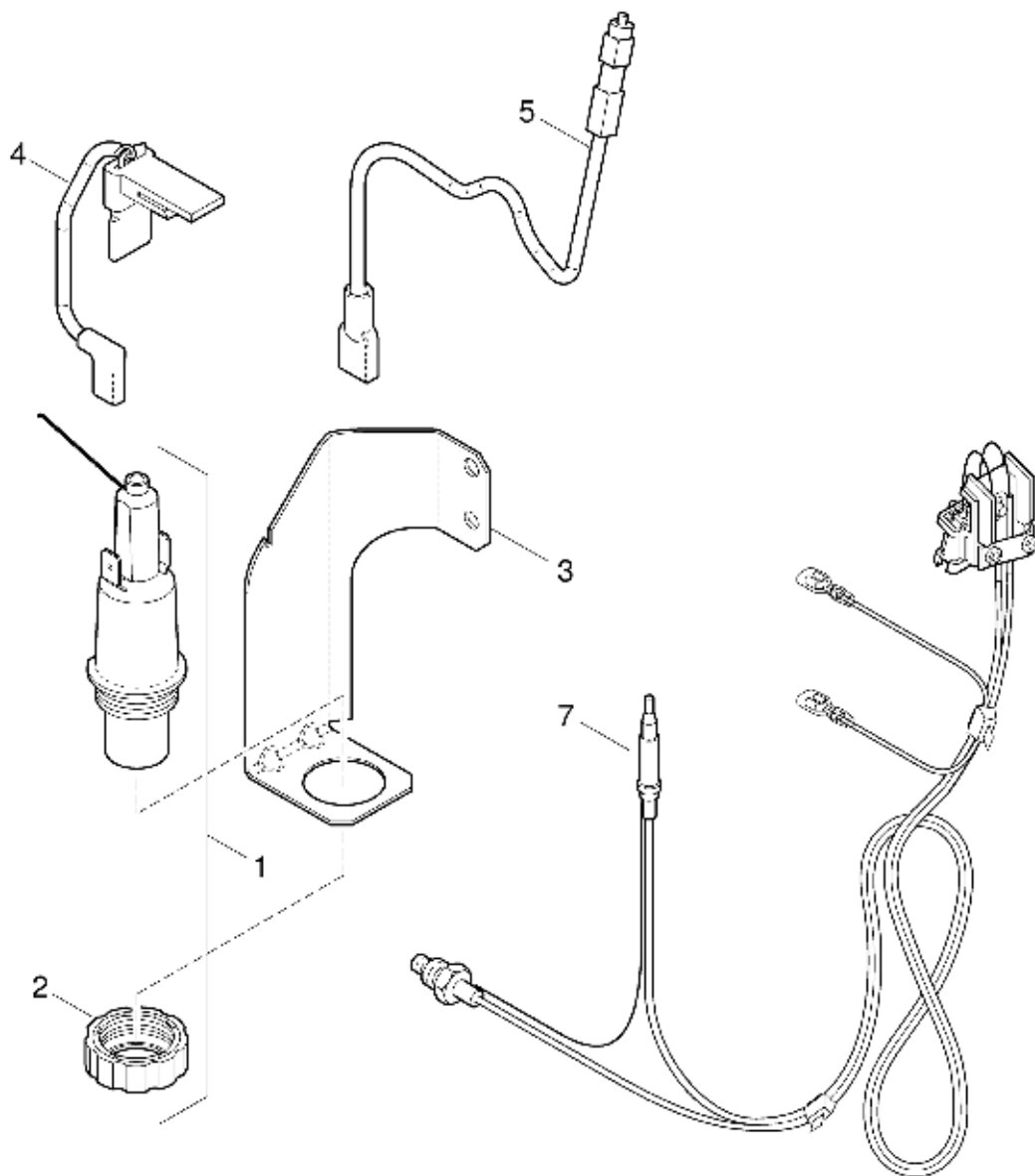

6720907431.AA JF

6

Piezo igniter
Piezozünder
Allumeur Piezo
Accenditore piezo
Piezoeléctrico

WR 8/10/11/13/14/15/18 P...

Pos	Description Bezeichnung Dénomination Descrizioni Descripción	S-Nr	Ordering no. Bestell-Nr. Numéro de commande N° d'ordine Número el ordenar	PG	Gas type Gasart Type gaz Tipo gas Tipo gas	WR	WR	WR	WR	WR	WR										Remarks Bemerkungen Remarques Osservazioni Observaciones
						8P	10P	11P	13P	14P	15P										
1	Piezo igniter		8 708 108 051 0	24		■	■	■	■	■	■										
2	Nut (10x)		8 743 301 025 0	12		■	■	■	■	■	■										
3	Fixing bracket		8 701 302 181 0	13		■	■	■	■	■	■										
4	Ignition locking device		8 707 101 002 0	20		■	■	■	■	■	■										
5	Sparking plug & Ignition lead		8 704 401 040 0	13		■	■	■	■	■	■										
7	Flue gas safety device	7895	8 707 206 455 0	29		■															<= FD004 (2010.04)
7	Flue gas safety device	7895	8 738 724 269	29		■															>= FD005 (2010.05)
7	Flue gas safety device	2595,5795,7595,7895	8 707 206 074 0	38			■	■	■	■	■	■									
WR 8/10/11/13/14/15/18 P...																			Piezo igniter Piezozünder Allumeur Piezo Accenditore piezo Piezoeléctrico		6

List of translations Übersetzungsliste		Liste des traductions Traduzione delle descrizioni	Lista de traducciones	
Pos	Beschreibung	Denomination	Descrizione	Descripción
1	Baugruppe	Groupe de construction	Gruppo di costruzione	Grupo de construccion
1	Mantel	Habillage	Mantello	Carcasa
2	Blende	Façade	Mascherina quadro comandi	Blenda frontal
3	Griff Wassermengenwähler	Manette sèlecteur de débit eau	Manopola	Mando selector de caudal
4	Strömungssicherung	Coupe tirage antirefouleur	Cappa fumi	Campana cortatiros
5	Abgasstutzen Ø110	Raccord buse de fumée Ø110	Terminale condotto Ø110	Acoplamiento salida gas Ø110
5	Abgasstutzen Ø130	Buse Dia 130	Terminale condotto Ø130	Acoplamiento salida gas Ø130
6	Schraube (10x)	Vis (10x)	Vite (10x)	Tornillo (10x)
7	Winkel	Equerre	Staffa	Angulo
8	Schraube M4,8x9,5 (10x)	Vis M4,8x9,5 (10x)	Vite M4,8x9,5 (10x)	Tornillo M4,8x9,5 (10x)
9	Klammer (10x)	Clip (10x)	Graffa (10x)	Grapa (10x)
2	Baugruppe	Groupe de construction	Gruppo di costruzione	Grupo de construccion
1	Innenkörper	Corps de chauffe	Corpo interno	Cuerpo de caldeo
2	Temperaturbegrenzer	Limiteur de température	Limitatore temperatura	Limitador de temperatura
3	Verbindungsrohr kalt	Tube arrivée eau	Tubo di raccordo acqua fredda	Tubo de agua fria
4	O-Ring (10x)	O-ring (10x)	Anello tenuta (10x)	Anillo tórico (10x)
5	Klammer (10x)	Clip (10x)	Graffa (10x)	Grapa (10x)
6	Bügel (10x)	Epingle (10x)	Fermo a molla (10x)	Clip de fijación (10x)
7	Flexschlauch	Tube flexible eau	Tubo flessibile	Tubo Flexible
8	Dichtung (10x)	Joint (10x)	Guarnizione (10x)	Junta (10x)
9	Anschlussbuchse	Connecteur	Raccordo	Casquillo
10	Temperaturbegrenzer	Limiteur de température	Limitatore temperatura	Limitador de temperatura
11	Klammer (10x)	Clip (10x)	Graffa (10x)	Clip (10x)
3	Baugruppe	Groupe de construction	Gruppo di costruzione	Grupo de construccion
1	Brenner	Brûleur	Brucciatore	Quemador
2	Düse (110) (10x)	Injecteur (110) (10x)	Ugello (110) (10x)	Tobera (110) (10x)
2	Düse (125) (10x)	Injecteur (125) (10x)	Ugello (125) (10x)	Tobera (125) (10x)
2	Düse (120) (10x)	Injecteur (120) (10x)	Ugello (120) (10x)	Tobera (120) (10x)
2	Düse (70) (10x)	Injecteur (70) (10x)	Ugello (70) (10x)	Tobera (70) (10x)
2	Düse (65) (10x)	Injecteur (65) (10x)	Ugello (65) (10x)	Tobera (65) (10x)
2	Düse (114) (10x)	Injecteur (114) (10x)	Ugello (114) (10x)	Tobera (114) (10x)
3	Düse (125) (10x)	Injecteur (125) (10x)	Ugello (125) (10x)	Tobera (125) (10x)
3	Düse (120) (10x)	Injecteur (120) (10x)	Ugello (120) (10x)	Tobera (120) (10x)
3	Düse (135) (10x)	Injecteur (135) (10x)	Ugello (135) (10x)	Tobera (135) (10x)
3	Düse (72) (10x)	Injecteur (72) (10x)	Ugello (72) (10x)	Tobera (72) (10x)
3	Düse (75) (10x)	Injecteur (75) (10x)	Ugello (75) (10x)	Tobera (75) (10x)
3	Düse (126)	Injecteur (126)	Ugello (126)	Tobera (126)
3	Düse (130) (10x)	Injecteur (130) (10x)	Ugello (130) (10x)	Tobera (130) (10x)
3	Düse (65) (10x)	Injecteur (65) (10x)	Ugello (65) (10x)	Tobera (65) (10x)
4	Schraube M3,5x10 (10x)	Vis M3,5x10 (10x)	Vite M3,5x10 (10x)	Tornillo M3,5x10 (10x)
5	Schraube (10x)	Vis (10x)	Vite (10x)	Tornillo (10x)
6	Anschlussstück	Raccord	Raccordo di collegamento	Racor
7	Dichtung (10x)	Joint (10x)	Guarnizione (10x)	Junta (10x)
8	O-Ring (10x)	O-ring (10x)	Anello tenuta (10x)	Anillo tórico (10x)
9	Klammer (10x)	Clip (10x)	Graffa (10x)	Grapa (10x)
11	Zündgasrohr	Tubulure de veilleuse	Tubetto spia	Tubo de gas al piloto
12	Hülse (10x)	Douille (10x)	Bocchetta (10x)	Manguito (10x)
13	Überzündbrücke	Tôle d'interallumage	Ponte accensione	Rampa de encendido
	Gasart-Umbausatz 23>31	Kit de transformation de gaz 23>31	Kit conversione gas 23>31	Kit de conversión de gas 23>31
	Gasart-Umbausatz 23>21	Kit de transformation de gaz 23>21	Kit conversione gas 23>21	Kit de conversión de gas 23>21
	Gasart-Umbausatz 23>31	Kit de transformation de gaz 23>31	Kit conversione gas 23>31	Kit de conversión de gas 23>31
	Gasart-Umbausatz 31>31 (50mbar)	Pochette Transformation 31>31 (50mbar)	Set di trasformazione 31>31 (50mbar)	Kit de transformacion 31>31 (50mbar)
	Gasart-Umbausatz 23>21	Kit de transformation de gaz 23>21	Kit conversione gas 23>21	Kit de conversión de gas 23>21
	Gasart-Umbausatz 23>31	Kit de transformation de gaz 23>31	Kit conversione gas 23>31	Kit de conversión de gas 23>31
	UR18 P 3-2 ZA	UR18 P 3-2 ZA	UR18 P 3-2 ZA	UR18 P 3-2 ZA
	UR11 P 3-2 ZA	UR11 P 3-2 ZA	UR11 P 3-2 ZA	UR11 P 3-2 ZA
	Conversion_kit Gas 23>31			

List of translations Übersetzungsliste		Liste des traductions Traduzione delle descrizioni	Lista de traducciones	
Pos	Beschreibung	Denomination	Descrizione	Descripción
	Gasart-Umbausatz 23>31	Kit de transformation de gaz 23>31	Kit conversione gas 23>31	Kit de conversión de gas 23>31
	Umbausatz 23>31	Kit de transformation de gaz	Kit conversione gas	Kit de conversión de gas
	Umbausatz 31>23			
	Gasart-Umbausatz 23>31	Kit de transformation de gaz 23>31	Kit conversione gas 23>31	Kit de conversión de gas 23>31
4	Baugruppe	Groupe de construction	Gruppo di costruzione	Grupo de construccion
1	Gasarmatur	Bloc gaz	Gruppo gas	Cuerpo de gas
3	Schraube (10x)	Vis (10x)	Vite (10x)	Tornillo (10x)
4	O-Ring 10x2,5 (10x)	O-ring (10x)	Anello tenuta (10x)	Anillo tórico (10x)
5	Dichtung (10x)	Joint (10x)	Guarnizione (10x)	Junta (10x)
6	Druckfeder	Ressort	Molla antagonista	Muelle
7	Gasventil (2)	Soupape gaz (2)	Valvola gas (2)	Platillo de válvula (2)
7	Gasventil (3)	Soupape gaz (3)	Valvola gas (3)	Platillo de válvula (3)
8	Gasventil (2)	Soupape gaz (2)	Piattello della valvola (2)	Asiento de válvula (2)
8	Gasventil (3)	Soupape gaz (3)	Piattello della valvola (3)	Asiento de válvula (3)
9	O-ring (10x)	O-ring (10x)	Anello tenuta (10x)	Anillo tórico (10x)
10	Zünddüse (3C)	Injecteur de veilleuse (3C)	Ugello spia (3C)	Inyector piloto (3C)
10	Zünddüse (4C) (10x)	Injecteur de veilleuse (4C) (10x)	Ugello spia (4C) (10x)	Inyector piloto (4C) (10x)
11	Gasventil	Soupape gaz	Valvola gas	Válvula piloto
12	Magneteinsatz	Tête magnétique	Magnete	Electroimán
13	Schraube (10x)	Vis (10x)	Vite (10x)	Tornillo (10x)
14	Schaltergehäuse	Support interrupteur	Gruppo accensione	Caja interruptor
15	Dichtung (10x)	Joint (10x)	Guarnizione (10x)	Junta (10x)
16	Ventilteller	Siège de soupape	Piattello della valvola	Platillo de válvula
17	Sicherungsscheibe (10x)	Circlips (10x)	Rondella (10x)	Arandela de seguridad (10x)
18	Führungsplatte	Plaque de guidage	Pulsantiera	Placa de guía
18	Führungsplatte	Curseur complet	Cursore	Placa de guía
19	Schraube DIN7981-ST4,2x9,5-F-H (10x)	Vis (10x)	Vite (10x)	Tornillo (10x)
20	Gaszuführungsrohr	Tuyau d'arrivée gaz	Raccordo	Tubo de entrada de gas
21	O-Ring (10x)	O-ring (10x)	Anello tenuta (10x)	Anillo tórico (10x)
22	Druckfeder	Ressort	Molla antagonista	Muelle
23	Verschlusschraube	Vis de fermeture	Vite di chiusura	Tornillo de cierre
24	Gasventil (GN)	Soupape gaz (GN)	Valvola gas (GN)	Platillo de válvula (GN)
24	Gasventil (LPG)	Soupape gaz (LPG)	Valvola gas (LPG)	Platillo de válvula (LPG)
25	Dichtscheibe (10x)	Joint (10x)	Guarnizione (10x)	Junta (10x)
5	Baugruppe	Groupe de construction	Gruppo di costruzione	Grupo de construccion
1	Wasserarmatur (Oval-Membran)	Robinet d'eau	Gruppo acqua	Cuerpo de agua (Memb. Oval)
2	Deckel	Couvercle	Coperchio	Tapa
3	Schraube (10x)	Vis (10x)	Vite (10x)	Tornillo (10x)
4	Stift (10x)	Goupille (10x)	Spina (10x)	Clavijas (10x)
5	Membrane (A)	Membrane (A)	Membrana (A)	Membrana (A)
5	Membrane (F)	Membrane (F)	Membrana (F)	Membrana (F)
5	Membrane (L)	Membrane (L)	Membrana (L)	Membrana (L)
5	Membrane (E)	Membrane (E)	Membrana (E)	Membrana (E)
6	Bügel (10x)	Epingle (10x)	Fermo a molla (10x)	Clip de fijación (10x)
7	Buchse	Douille	Buccola	Manguito
8	O-Ring (10x)	O-ring (10x)	Anello tenuta (10x)	Anillo tórico (10x)
9	Bügel (10x)	Epingle (10x)	Fermo a molla (10x)	Clip de fijación (10x)
10	Wählerschraube	Vis de réglage	Selettore	Tornillo selector de caudal
11	O-Ring (10x)	O-ring (10x)	Anello tenuta (10x)	Anillo tórico (10x)
12	Spindel	Goupille	Perno	Vástago
13	Wassersieb	Filtre eau	Filtro acqua	Filtro de agua
14	O-Ring (10x)	O-ring (10x)	Anello tenuta (10x)	Anillo tórico (10x)
15	Wassermengenregler	Regulateur de débit eau	Dosatore portata acqua	Estabilizador de caudal
16	O-Ring (10x)	O-ring (10x)	Anello tenuta (10x)	Anillo tórico (10x)
17	Venturi (23 S)	Venturi (23S)	Venturi (23S)	Venturi (23S)
18	O-Ring (10x)	O-ring (10x)	Anello tenuta (10x)	Anillo tórico (10x)
19	Buchse	Couvercle	Coperchio	Tapa

Types of appliances Gerätetypen	Types de chaudières Tipo apparecchi		Tipos de aplicaciones	
Appliance Gerät Chaudière Apparecchio Aparato	Ordering no. Bestell-Nr. Numéro de commande N° d'ordine Número el ordenar	Country Land Pays Paese Paese	S-Nr. S-Nr. S-Nr. S-Nr.	Remarks Bemerkungen Remarques Osservazioni Observaciones
WR 8 P 31	7 701 431 556	Austria,Belgium,Croatia,France,Germany,I	7895	
WR 8 P 31	7 701 431 592	Austria,Belgium,Croatia,France,Germany,I	7895	
WR 11 P31 S7895	7 701 431 591	Austria,Belgium,Croatia,France,Germany,I	7895	
WR11 P23 S7595	7 701 331 736	Austria,Croatia,Czech Republic,Estonia,L	7595	
WR14 P23 S7595	7 702 331 801	Austria,Croatia,Czech Republic,Estonia,L	7595	
WR10 P23 S5795 RA	7 701 331 629	Belarus,Ukraine	5795	
WR10P23S5795	7 701 331 731	Belarus,Ukraine	5795	
WR13 P23 S5795	7 702 331 769	Belarus,Ukraine	5795	
WR15 P23 S5795	7 703 331 800	Belarus,Ukraine	5795	
WR11 P23 S2595	7 701 331 676	South Africa	2595	
WR11 P31 S2595	7 701 431 572	South Africa	2595	
WR18 P23 S2595	7 703 331 783	South Africa	2595	
WR18 P31 S2595	7 703 431 770	South Africa	2595	
WR11 P23 S5795	7 701 331 622	Ukraine	5795	



BOSCH

Bosch Thermotechnik GmbH
Junkersstr. 20-24
D-73249 Wernau / Germany