

WR275/350/440-7K.G...

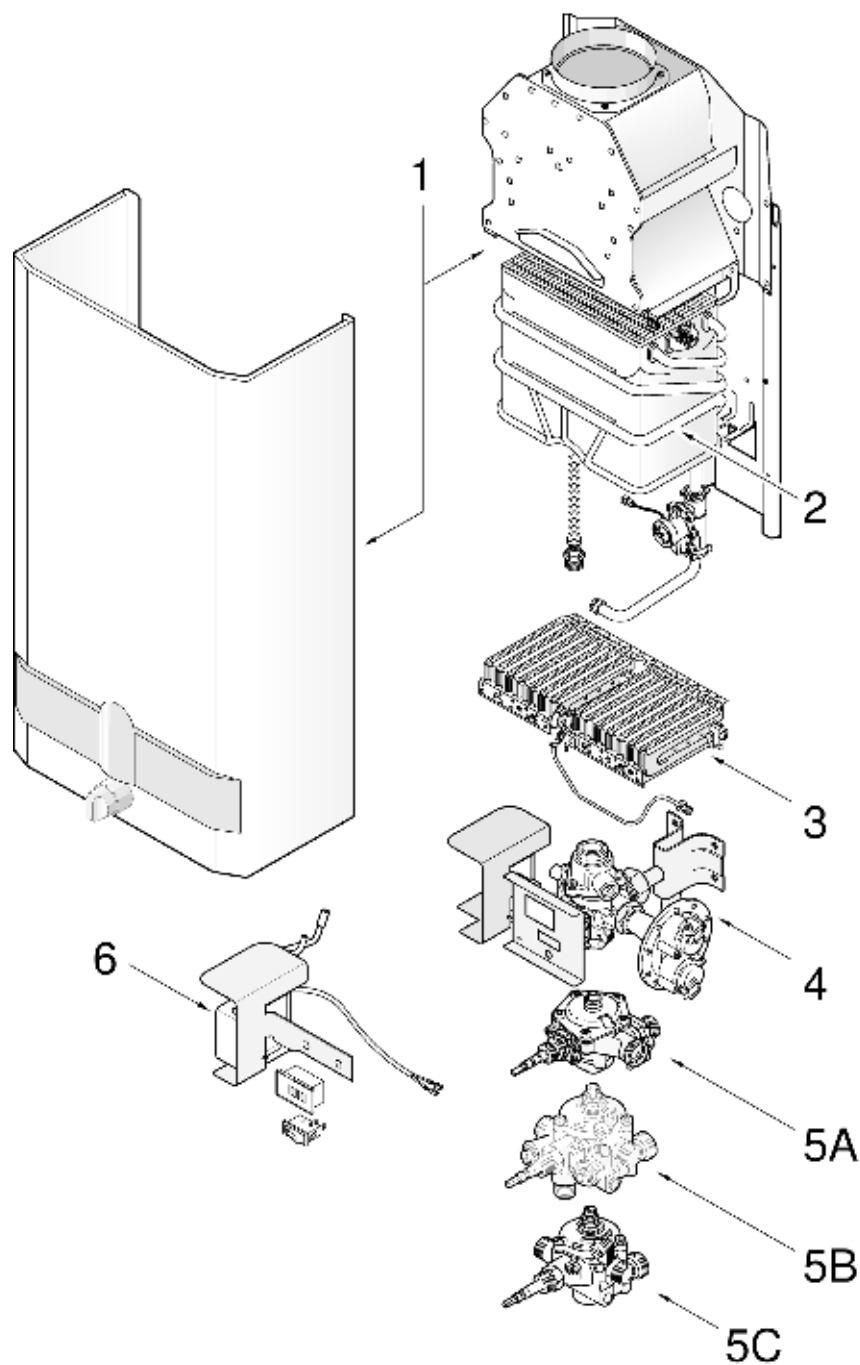

6720609090 AA JF

[de] Wichtige Hinweise zur Installation/Montage

Die Installation/Montage muss durch eine für die Arbeiten zugelassene Fachkraft unter Beachtung der geltenden Vorschriften erfolgen.

[en] Important notes on installation/assembly

The installation/assembly must be carried out by a professional who is authorised to do the work, and with due regard to the relevant regulations.

[fr] Instructions importantes pour l'installation/le montage

L'installation/le montage doit être effectué(e) par un spécialiste qualifié pour les opérations concernées et dans le respect des prescriptions applicables.

[bg] Важни указания във връзка с инсталацията/монтажа

Инсталацията/монтажът трябва да се извършва от лицензиран за работите специалист в съответствие с приложимите разпоредби.

[cs] Důležité pokyny k instalaci/montáži

Instalaci/montáž musí při dodržení platných předpisů provést odborný pracovník s příslušným oprávněním pro tyto práce.

[da] Vigtige anvisninger til installationen/monteringen

Installationen/monteringen skal foretages af en godkendt installatør under overholdelse af de gældende forskrifter.

[el] Σημαντικές υποδείξεις για την εγκατάσταση/συναρμολόγηση

Η εγκατάσταση/συναρμολόγηση πρέπει να πραγματοποιείται από εξουσιοδοτημένο για τις εργασίες αυτές τεχνικό προσωπικό, το οποίο θα πρέπει να φροντίζει ώστε να τηρούνται οι ισχύουσες διατάξεις.

[es] Indicaciones importantes para instalación/montaje

La instalación/el montaje lo debe realizar personal especializado autorizado para los trabajos, respetando las prescripciones vigentes.

[et] Olulised juhised paigaldamiseks/montaažiks

Paigaldamist/montaaži tohib läbi viia selleks volitusi omav spetsialist, arvestades kehtivaid nõudeid.

[fi] Belangrijke aanwijzingen betreffende de installatie/montage

De installatie/montage moet worden uitgevoerd door een voor de werkzaamheden geautoriseerde installateur. Hij moet rekening houden met de geldende voorschriften.

[fi] Tärkeitä asennus- ja kokoonpano-ohjeita

Näihin töihin hyväksytyn ammattiasentajan pitää suorittaa asennus- ja kokoonpanotyöt voimassa olevien määräysten mukaisesti.

[hu] Fontos tudnivalók az installáláshoz/szereléshez

Az installálás/szerelést egy, a munkákra felhatalmazott szakembernek kell végeznie, az érvényes előírások figyelembevételével.

[it] Avvertenze importanti per l'installazione/il montaggio

L'installazione/il montaggio deve aver luogo ad opera di una ditta specializzata ed autorizzata in osservanza delle disposizioni vigenti.

[he] מובחנות/הנחיות חשובות לביצוע/התקנת המוצר

התקנת המוצר/התקנת המוצר חייבת להיעשות על ידי מומחה/מקצוען מוסמך/מורשה, תוך שמירה על כללי הבטיחות וההנחיות הישירות.

[lt] Svarbios instaliavimo ir (arba) montavimo nuorodos

Instaliuoti ir montuoti, laikantis galiojančių taisyklių, leidžiama kvalifikuotiems specialistams, kurie buvo įgalioti šiems darbams atlikti.

[lv] Svarīgi norādījumi par iekārtas uzstādīšanu / montāžu

Iekārtas uzstādīšanu/montāžu ir jāveic specializētam sertificētam speciālistam, ievērojot spēkā esošos noteikumus.

[nl] Belangrijke aanwijzingen betreffende de installatie/montage

De installatie/montage moet worden uitgevoerd door een voor de werkzaamheden geautoriseerde installateur rekening houdend met de geldende voorschriften.

[no] Viktig informasjon om installasjon/montering

Installasjonen/monteringen skal gjennomføres av autoriserte installatører, og gjeldende forskrifter skal følges.

[pl] Ważne wskazówki dotyczące instalacji/montażu

Instalacja/montaż muszą być wykonane przez uprawnionego do tego rodzaju prac specjalistę przy zachowaniu obowiązujących przepisów.

[pt] Indicações importantes relativas à instalação/montagem

A instalação/montagem deve ser efetuada por um técnico especializado com qualificações para estes trabalhos, tendo em atenção os regulamentos em vigor.

[ro] Indicații importante privind instalarea/montajul

Instalarea/montajul trebuie realizate de către un specialist autorizat pentru lucrările respective, respectându-se prescripțiile valabile.

[ru] Важные указания по подключению/монтажу

Подключение/монтаж должны выполнять специалисты, имеющие допуск к выполнению таких работ, при соблюдении действующих норм и правил.

[sk] Dôležité pokyny týkajúce sa inštalácie/montáže

Inštaláciu/montáž musí realizovať odborník s oprávnením na výkon týchto prác, pričom musí dodržiavať platné predpisy.

[sl] Pomembni napotki za namestitvev/montažo

Namestitvev/montažo mora izvesti strokovnjak, pristojen za tovrstna dela, ob upošte vanju veljavnih predpisov.

[sr] Važna uputstva za ugradnju i montažu

Ugradnju i montažu moraju da obave samo stručna lica ovlašćena za izvođenje takvih radova koja će poštovati važeće propise.

[sv] Viktiga anvisningar för installation/montering

Installationen/monteringen måste utföras av en behörig och fackkunnig person enligt gällande föreskrifter.

[tr] Kurulum/Montaj ile ilgili önemli uyarılar

Kurulum/Montaj çalışmaları sadece yetkili bayiler tarafından aşağıda belirtilen talimatlar dikkate alınarak yapılmalıdır.

[uk] Важливі вказівки щодо установки/монтажу

Установку/монтаж мають здійснювати фахівці, що мають дозвіл на проведення цих робіт, із дотримання чинних приписів.

[zh] 安装方面的重要提示

必须由受到许可承担该项工作的专业人员遵照相关法规进行安装。

[ar] ملاحظات هامة للتركيب/التجميع

يجب أن يتم التركيب/التجميع من قبل متخصص مصرح له بالعمل، مع مراعاة اللوائح السارية.

[fa] تذکرات مهم درباره نصب/مونتاژ

نصب/مونتاژ باید توسط فردی حرفه ای که مجاز به انجام این کار است، و همچنین با توجه کامل به مقررات مربوطه انجام شود.

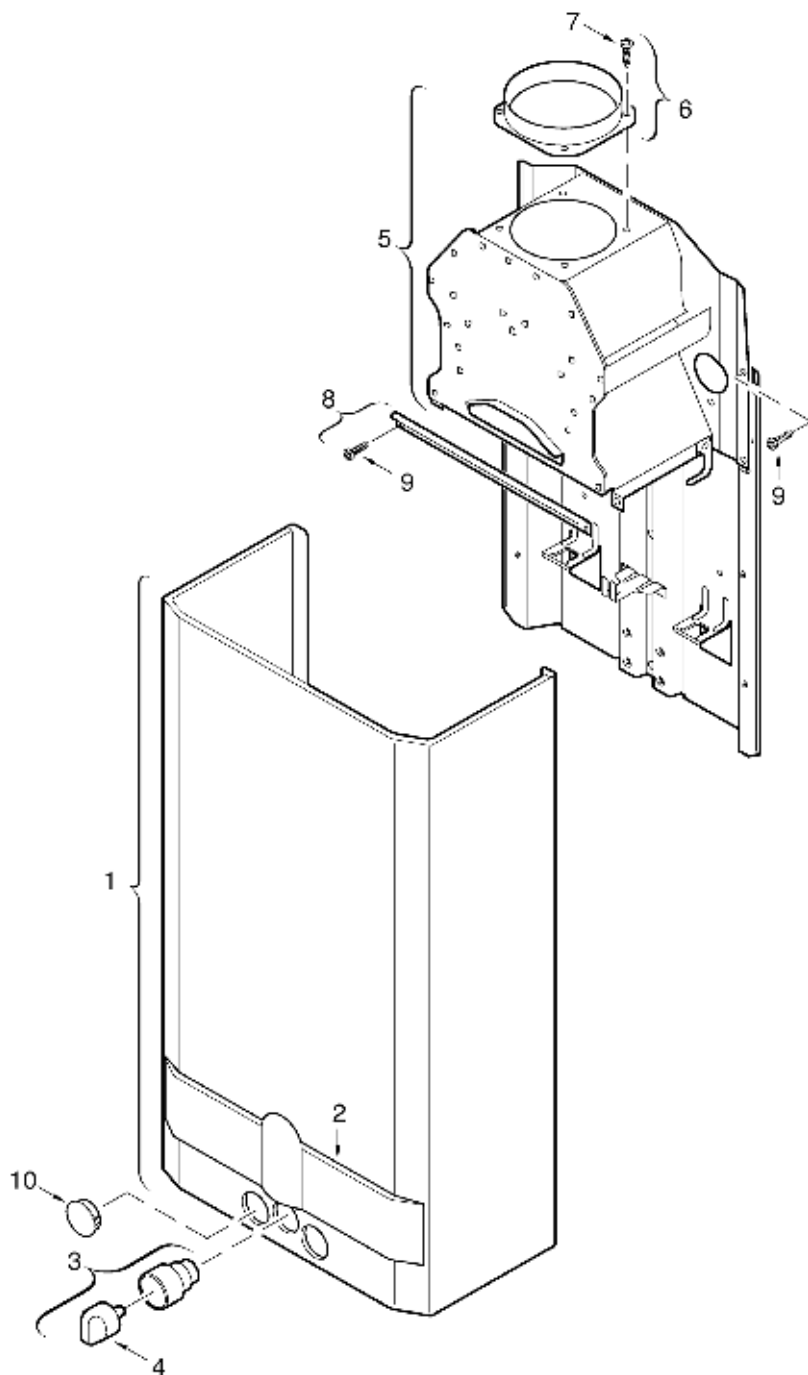

6720602579 AA.IF

1
Front cover
Mantel
Habillage
Mantello
Mantel
Frente

WR275/350/440-7K.G...

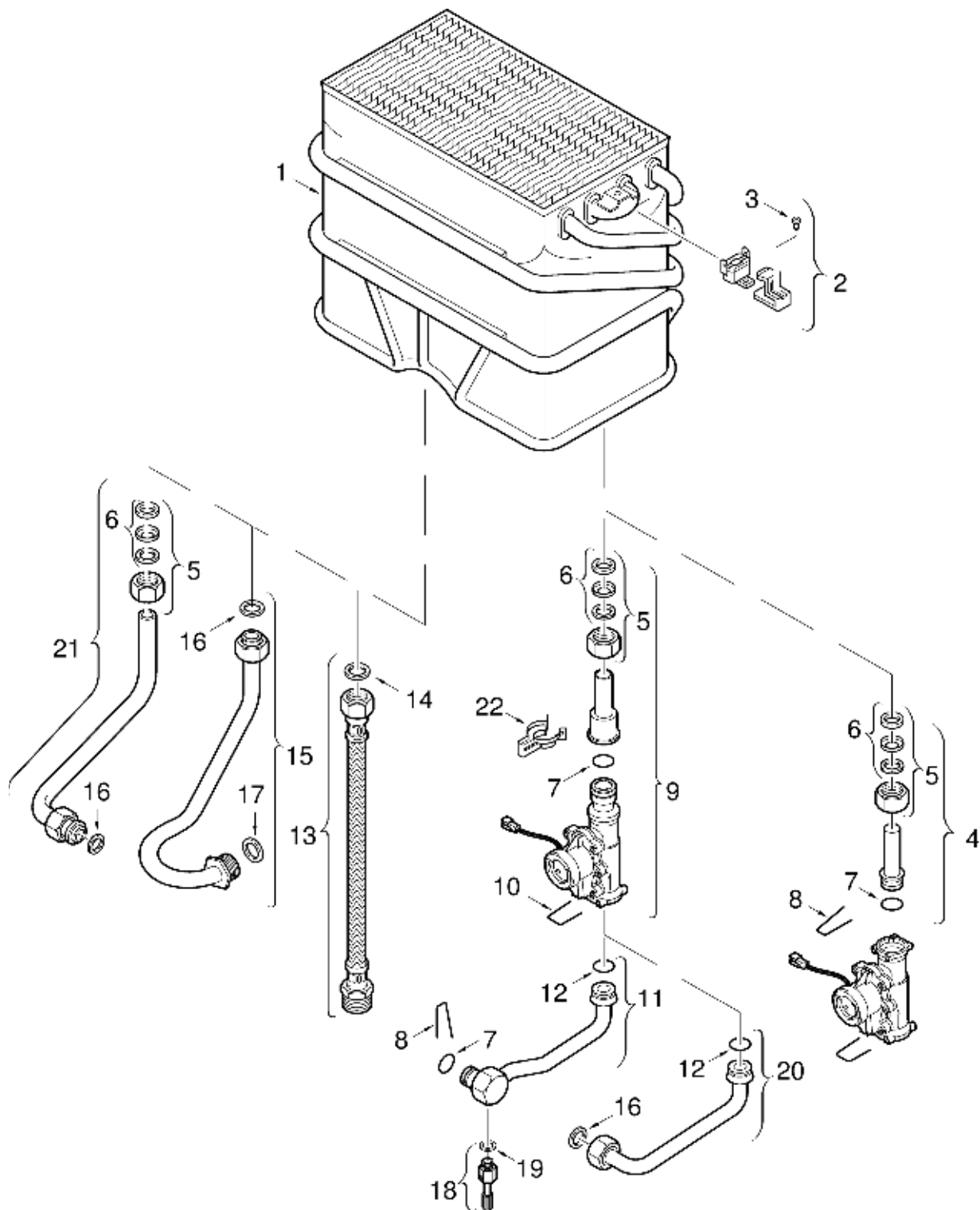

672060900 AA.JF

2

Heating body/Hydrogenerator
Innenkörper/Hydrogenerator
Corps interieur/Hydrogénérateur
Corpo interno/Hdrogeneratore
Binnenwerk/Hydrogenerator
Câmara de combustão/Hidrogerador

WR275/350/440-7K.G...

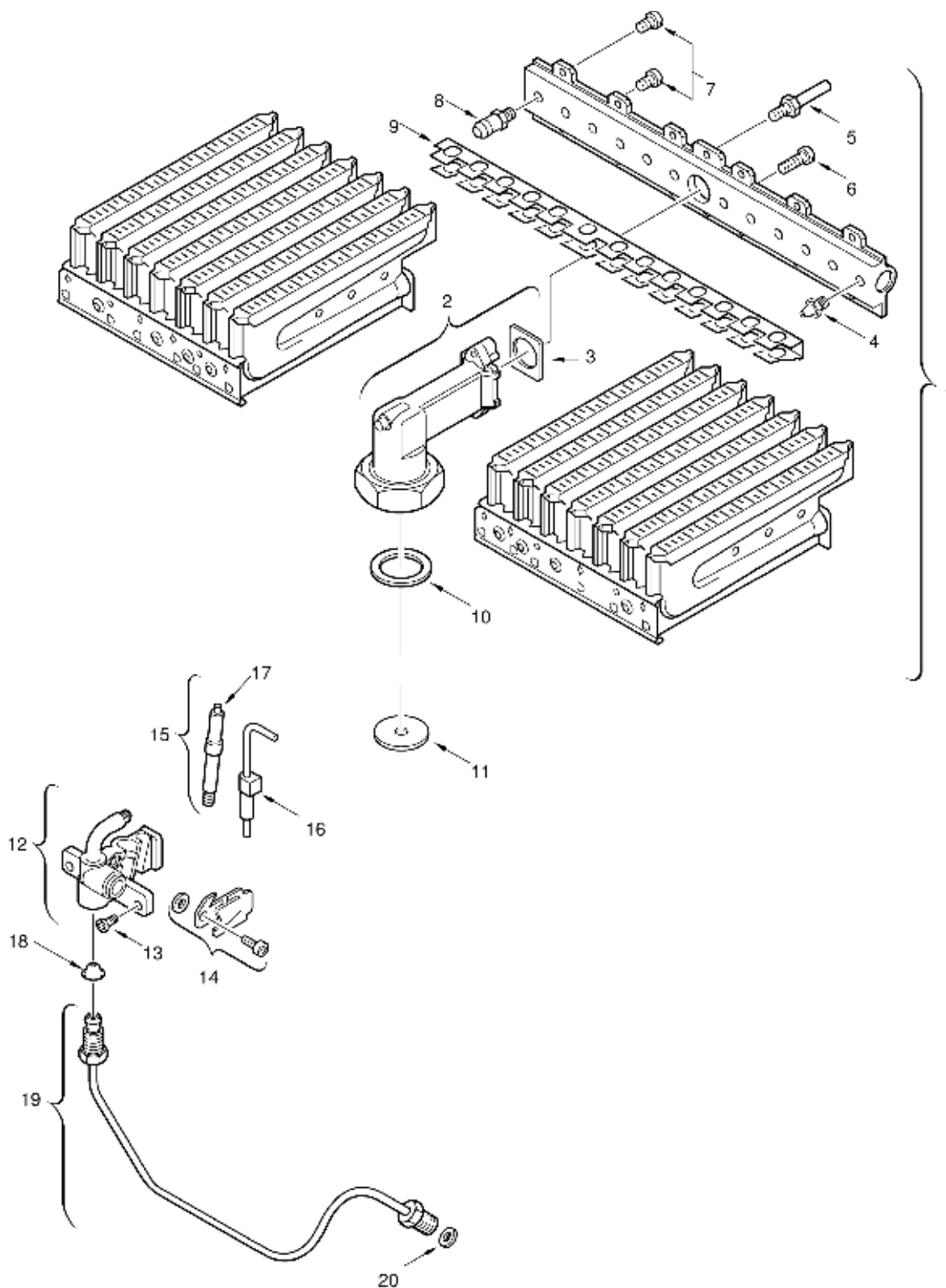

870X600M7 AA.IF

3

Burner
Brenner
Brûleur
Bruciatore
Brander
Queimador

WR275/350/440-7K.G...

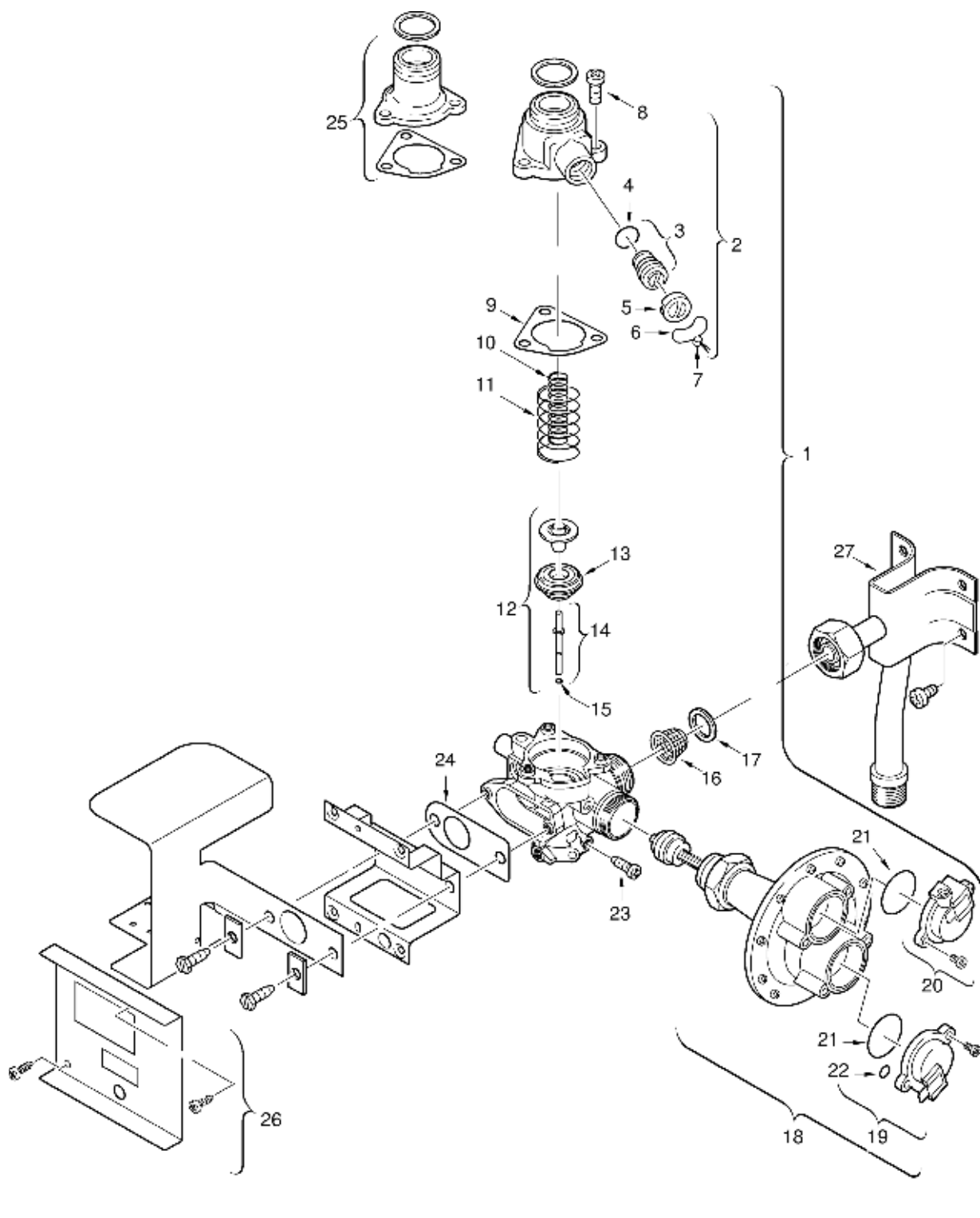

#F29010194R A.A. IF

4

Gas valve
Gasarmatur
Bloc gaz
Gruppo gas
Gasregelblok
Automático de gás

WR275/350/440-7K.G...

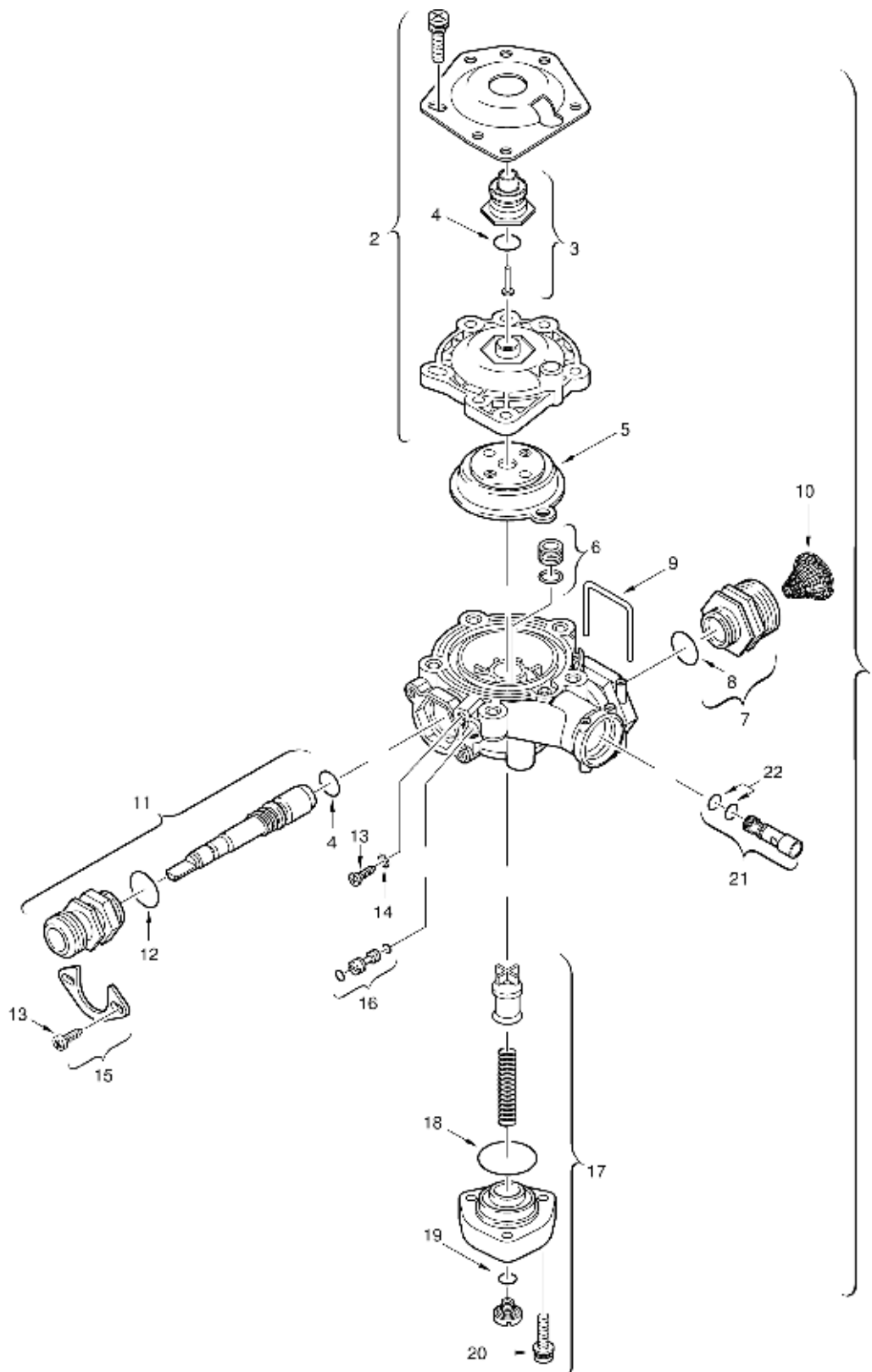

6720602246.M.F

5

Water valve multi point (plastic)
Wasserarmatur Fernzapfer (Kunststoff)
Robinet d'eau à distance (plastique)
Gruppo acqua prelievo a distanza in plas
Waterdeel bij tap punt op afstand (Kunst
Automático de água C/abast. Distância (P

WR275/350/440-7K.G...

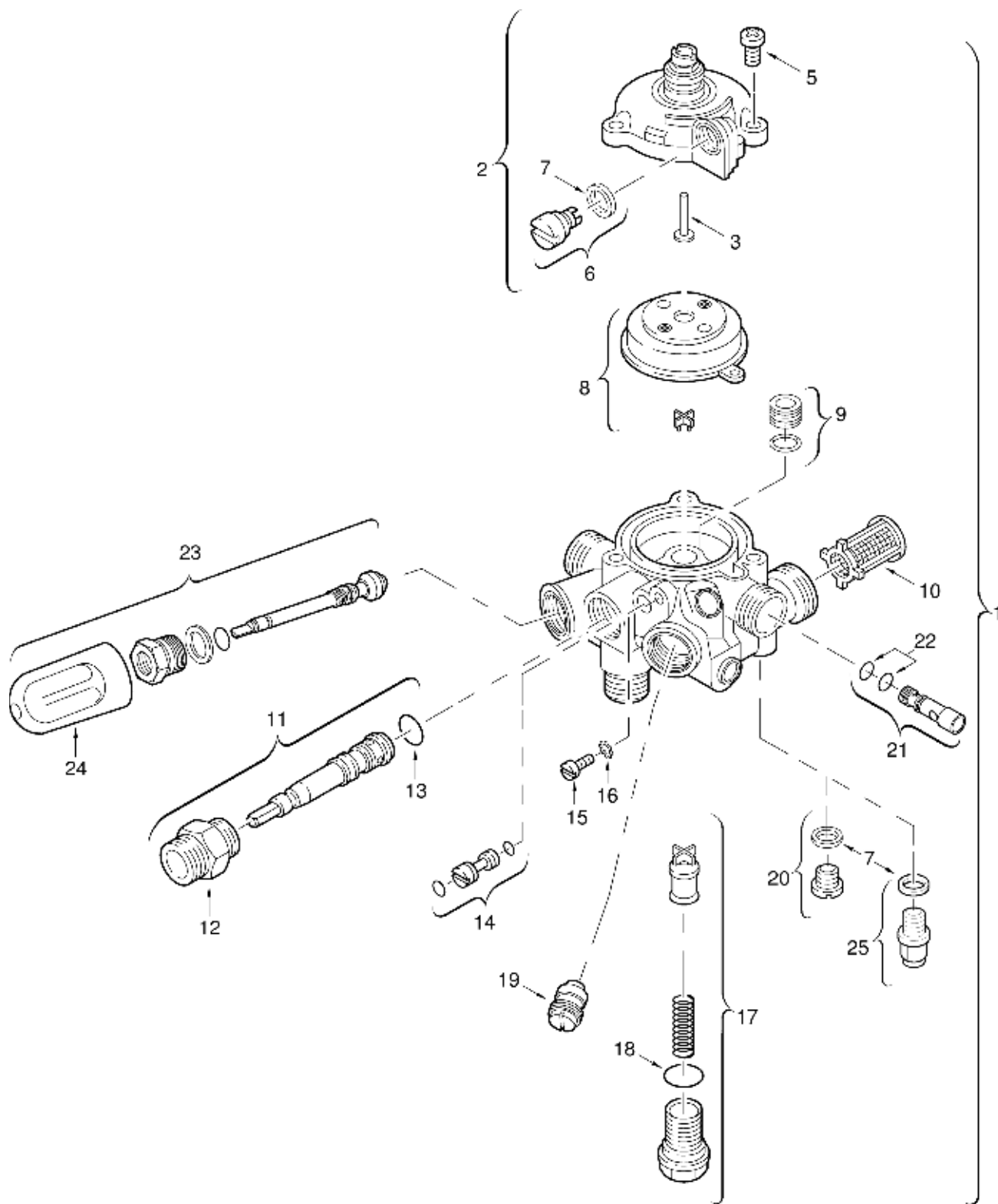

6720601767 AC - IF

5 Water valve
Wasserarmatur
Vanne d'eau
B Gruppo acqua
Waterdeel
Automático de água

WR275/350/440-7K.G...

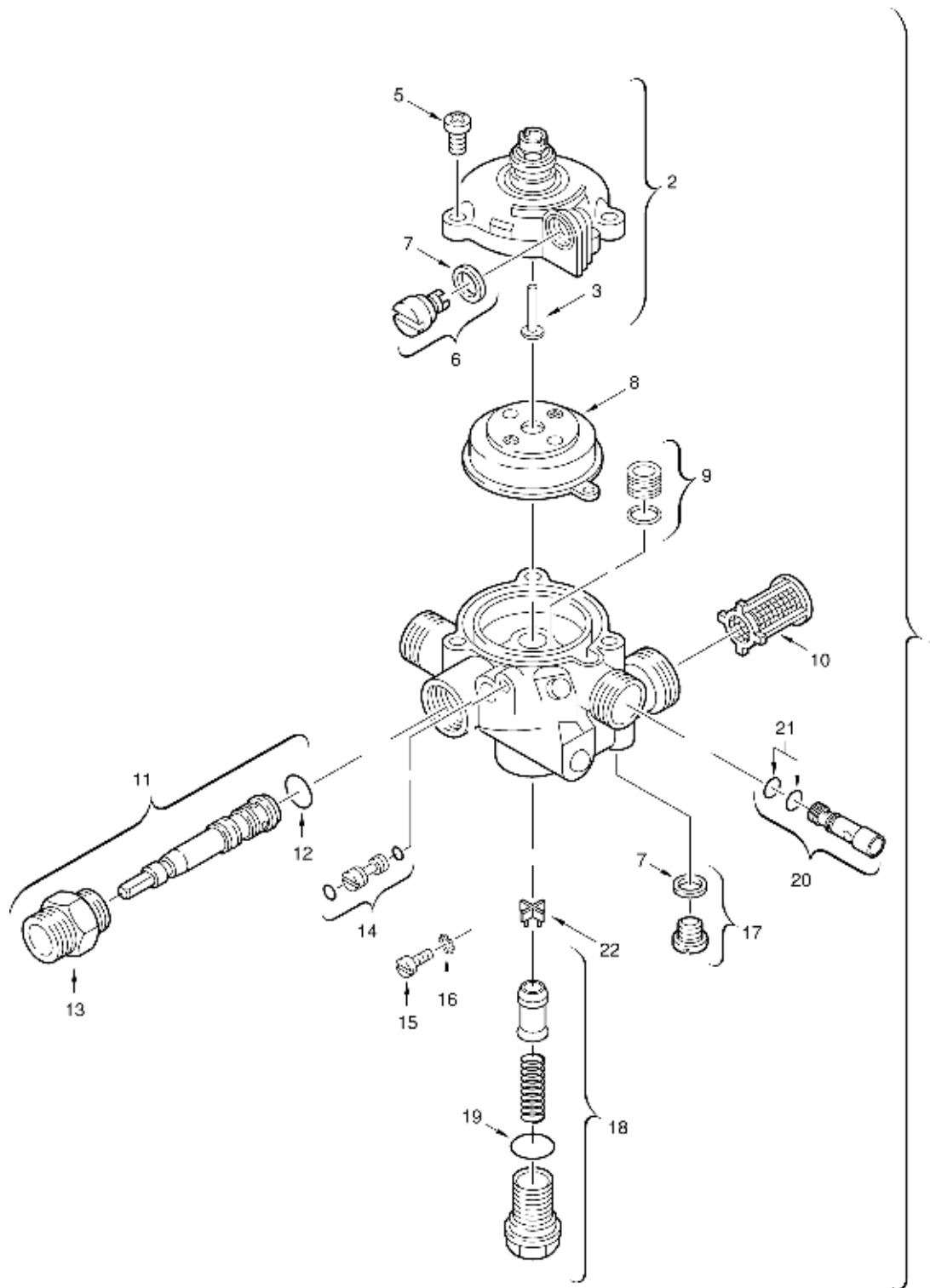

6720903004.AB JF

5
C

Water valve multi point (brass)
Wasserarmatur Fernzapfer (Messing)
Robinet d'eau à distance (laiton)
Gruppo acqua prelievo a distanza in ott
Waterdeel bij tap punt op afstand (Messi
Automático de água C/abast. Distância (

WR275/350/440-7K.G...

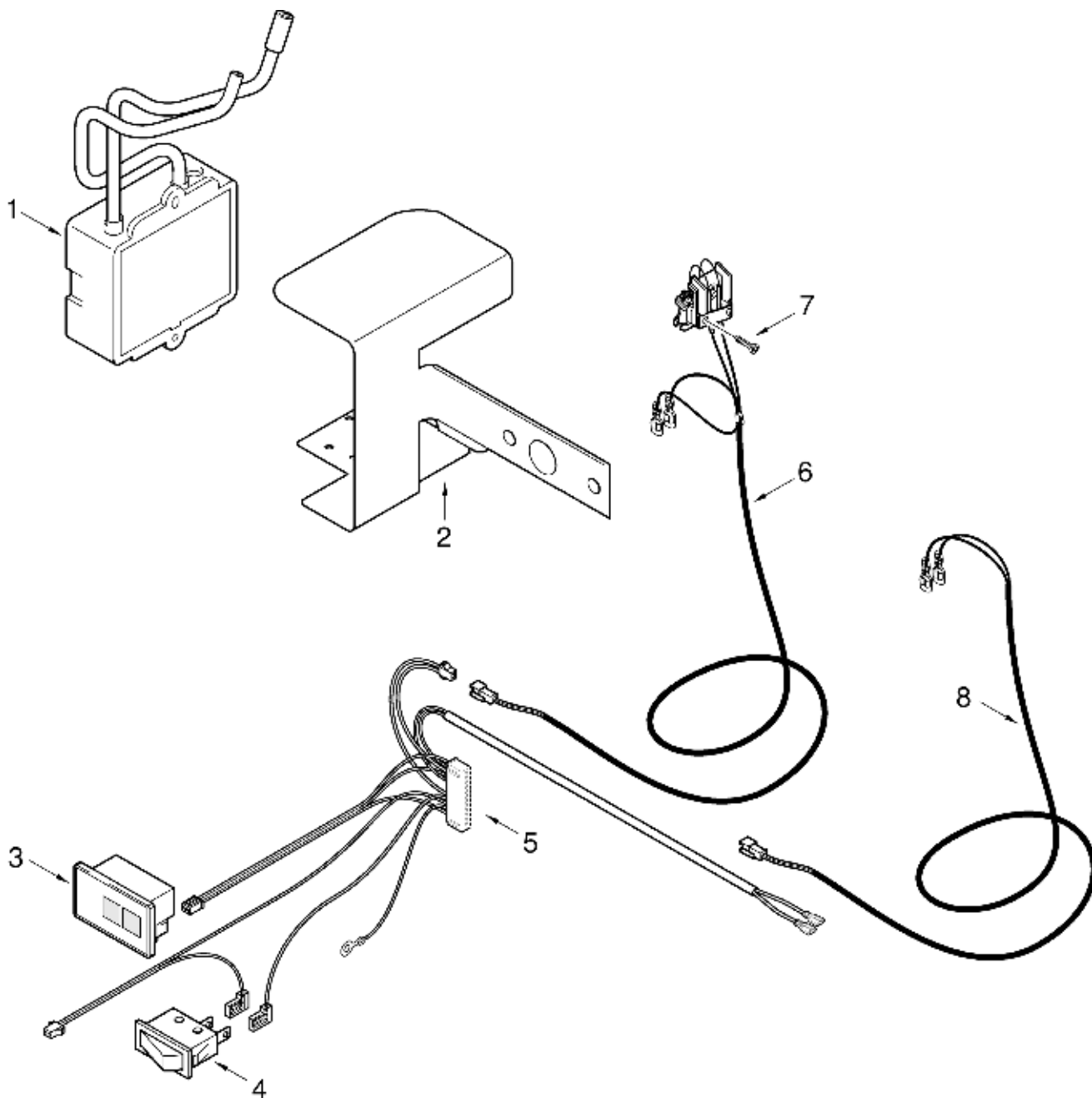

6720002251 AA JF

6

Ignition unit
Zündbaustein
Unité d'allumage
Vite lenta accensione
Ontstekingsstrafo
Unidade de ignição

WR275/350/440-7K.G...

List of translations Übersetzungsliste		Liste des traductions Traduzione delle descrizioni		Vertalinglijst Lista das traduções	
Pos	Beschreibung	Denomination	Descrizione	Benaming	Descrि#o
1	Baugruppe	Groupe de construction	Gruppo di costruzione	Montagegroep	Elemento da construç#o
1	Mantel	Habillage	Habillage	MANTEL PRISMA WR 275-7KG HYDROPOWER	Frente
2	Blende	Cache	Mascherina	MANTELPLAAT M/KLEPJE (+ DUWKNOPPEN) WR 2	Espelho
3	Griff Wassermengenwähler	Manette s#lecteur de débit eau	Manopola con boccola	Knop + schroefhuls	Manípulo selector completo
4	Griff	Manette	Manopola	Knop temperatuur geiser	Manipulo selector caudal de água
5	Strömungssicherung	Anti-refouleur	Cappa fumi	Trek- en windonderbreker	Chaminé
6	Abgasstutzen #110	Raccord buse de fumée #110	Terminale condotto #110	Gasafvoer	Anel da chaminé #110
6	Abgasstutzen #130	Buse Dia 130	Terminale condotto #130	Rookgasafvoer #130	Anel da chaminé #130
7	Schraube DIN7981 3,9x9,5 (10x)	Vis DIN7981 3,9x9,5 (10x)	Vite DIN7981 3,9x9,5 (10x)	Schroef DIN7981 3,9x9,5 (10x)	Parafuso DIN7981 3,9x9,5 (10x)
8	Winkel	Equerre	Staffa	Hoeksteun	Suporte de fixaç#o
9	Schraube M4,8x9,5 (10x)	Vis M4,8x9,5 (10x)	Vite M4,8x9,5 (10x)	Schroef M4,8x9,5 (10x)	Parafuso M4,8x9,5 (10x)
10	Deckel (10x)	Couvercle (10x)	Coperchio (10x)	Blindeerdop (10 x)	Tampa (10x)
2	Baugruppe	Groupe de construction	Gruppo di costruzione	Montagegroep	Elemento da construç#o
1	Innenkörper	Corps de chauffe	Corpo interno	Binnenwerk	Câmara de combust#o
2	Temperaturbegrenzer	Limiteur de température	Limitatore temperatura	Maximaal thermostaat	Limitador de temperatura
3	Schraube (10x)	Vis (10x)	Vite (10x)	Schroef (10 x)	Parafuso (10x)
4	Verbindungsrohr	Tube de raccordement	Raccordo	Verbindingsleiding	Tubo de água
5	Verschraubung	Raccord	Raccordo	Koppeling	Uni#o roscada
6	Dichtungssatz	Sachet de joints	Set di guarnizioni	Set pakkingen	Conjunto de vedantes
7	O-Ring (10x)	O-ring (10x)	Anello tenuta (10x)	O-ring (10 x)	O-ring (10x)
8	Bügel (10x)	Epingle (10x)	Fermo a molla (10x)	Borgveer (10 x)	Freio (10x)
9	Hydrogenerator assy.	Hydrogénérateur compl.	Idrogeneratore compl.	Hydrogenerator	Hidrogerador compl.
10	Bügel (10x)	Epingle (10x)	Fermo a molla (10x)	Borgveer (10 x)	Freio (10x)
11	Verbindungsrohr kalt	Tube arrivée eau	Tubo di raccordo acqua fredda	Verbindingsleiding koudwater	Tubo ligaç#o água fria
12	O-Ring (10x)	O-ring (10x)	Anello tenuta (10x)	O-ring (10 x)	O-ring (10x)
13	Flexschlauch	Tube flexible eau chaude	Tubo flessibile	Flexibleslang	Ligaç#o de mangueira
14	Dichtung (10x)	Joint (10x)	Guarnizione (10x)	Pakkingring (10 x)	Anilha de vedaç#o (10x)
15	Verbindungsrohr warm	Tuyauterie chaud	Raccordo caldo	BUIS LINKS (PA-VALVE) W/WR	Tubo ligaç#o de água quente
16	Dichtung 18.6x13.5x1.5 (10x)	Joint 18.6x13.5x1.5 (10x)	Guarnizione 18.6x13.5x1.5 (10x)	Afdichtring 18.6x13.5x1.5 (10x)	Anilha de vedaç#o 18.6x13.5x1.5 (10x)
17	Dichtung 23.9x17.2x1.5 (10x)	Joint 23.9x17.2x1.5 (10x)	Guarnizione 23.9x17.2x1.5 (10x)	Afdichtring 23.9x17.2x1.5 (10x)	Anilha de vedaç#o 23.9x17.2x1.5 (10x)
18	Auslaufventil	Soupape de supression	Valvola mandata	Aftapschroef	Válvula de sobre press#o
19	Dichtscheibe (10x)	Joint (10x)	Guarnizione (10x)	Pakkingring (10 x)	Anel de vedaç#o (10x)
20	Verbindungsrohr kalt	Tube entree sanitaire	Raccordo freddo	Verbindingspijp boven	Tubo ligaç#o água fria
21	Verbindungsrohr warm	Tube sortie sanitaire	Raccordo caldo	Verbindingspijp warm	Tubo de ligaç#o de água quente
22	Klammer (10x)	Clip (10x)	Graffa (10x)	Klem (10 x)	Grampo (10x)
3	Baugruppe	Groupe de construction	Gruppo di costruzione	Montagegroep	Elemento da construç#o
1	Brenner	Br#leur	Brucciatore	BRANDER "23" W/WR 325-1K/1A/-1K/3K..B (N	Queimador
1	Brenner	Br#leur	Brucciatore	Brander	Queimador
2	Anschlussstück	Raccord	Raccordo di collegamento	Aansluitstuk	Peça de ligaç#o
3	Dichtung (10x)	Joint (10x)	Guarnizione (10x)	Pakkingsring (10 x)	Vedante (10x)
4	Düse (125) (10x)	Injecteur (125) (10x)	Ugello (125) (10x)	Spuitstuk (125) (10x)	Injector (125) (10x)
4	Düse (74) (10x)	Injecteur (74) (10x)	Ugello (74) (10x)	Spuitstuk (74) (10x)	Injector (74) (10x)
4	Düse (72) (10x)	Injecteur (72) (10x)	Ugello (72) (10x)	Spuitstuk (72) (10x)	Injector (72) (10x)
4	Düse (75) (10x)	Injecteur (75) (10x)	Ugello (75) (10x)	Spuitstuk (75) (10x)	Injector (75) (10x)
4	Düse (146) (10x)	Injecteur (146) (10x)	Ugello (146) (10x)	Spuitstuk (146) (10x)	Injector (146) (10x)
4	Düse (130) (10x)	Injecteur (130) (10x)	Ugello (130) (10x)	Spuitstuk(140) (10 x)	Injector (130) (10x)
5	Schraube (10x)	Vis (10x)	Vite (10x)	Schroef (10 x)	Parafuso (10x)
6	Schraube (10x)	Vis (10x)	Vite (10x)	Schroef (10 x)	Parafuso (10x)
7	Schraube M3,5x10 (10x)	Vis M3,5x10 (10x)	Vite M3,5x10 (10x)	Schroef M3,5x10 (10x)	Parafuso M3,5x10 (10x)
8	Druckmeßnippel	Prise de pression	Presa pressione	Meetnippel	Apoio manómetro
9	Überzündbrücke	Tôle d'interallumage	Ponte accensione	Ontstekingsbrug	Ponte de sobre-ignic#o
10	Dichtscheibe 1" (10x)	Joint 1" (10x)	Guarnizione 1" (10x)	Pakking (10 x)	Anel de vedaç#o 1" (10x)
11	Drosselscheibe (4,0) (10x)	Diaphragme (4,0) (10x)	Disco strozzatore (4,0) (10x)	Restrictie (4,0) (10 x)	Anilha de estrangulamento (4,0) (10x)
11	Drosselscheibe (6,0)	Diaphragme (6,0)	Disco strozzatore (6,0)	DIAFRAGMA 6,0MM WR 275-7KG "31"	Anilha de estrangulamento (6,0)
12	Zündbrenner (45)	Veilleuse (45)	Brucciatore spia pilota (45)	Waakvlambrander (45)	Queimador piloto (45)
12	Zündbrenner (30)	Veilleuse (30)	Brucciatore spia pilota (30)	Aansteekbrander	Queimador piloto (30)
13	Schraube (10x)	Vis (10x)	Vite (10x)	Schroef	Parafuso (10x)

List of translations Übersetzungsliste		Liste des traductions Traduzione delle descrizioni		Vertalinglijst Lista das traduções	
Pos	Beschreibung	Denomination	Descrizione	Benaming	Descrि#o
14	Befestigungsblech	Patte de fixation	Lamiera di protezione	Beugel	Chapa de fixaç#o
15	Elektrodensatz	Jeu d'électrodes	Set di elettrodi	Ontstekingselektrode	Conjunto electrodos
16	Ionisationselektrode	Electrode de ionisation	Elettrodo ionizzazione	Ionisatiepen	Sonda de ionizaç#o
17	Zündbolzen	Électrode d'allumage	Candeletta d'accensione	Ontstekingselektrode	Vela de igniç#o
18	Zünddüse (13) (10x)	Injecteur de veilleuse (13) (10x)	Ugello spia (13) (10x)	Waakvlampspuitstuk (10 x)	Injector piloto (13) (10x)
18	Zünddüse (74) (10x)	Injecteur de veilleuse (74) (10x)	Ugello spia (74) (10x)	Waakvalampspuitstuk (74) (10x)	injector piloto (74) (10x)
19	Zündgasrohr	Tubulure de veilleuse	Tubetto spia	Gasleiding waakvlam	Tubo de gás piloto
20	Dichtring (10x)	Joint (10x)	Guarnizione (10x)	Pakkingring (10 x)	Anilha de vedaç#o (10x)
4	Baugruppe	Groupe de construction	Gruppo di costruzione	Montagegroep	Elemento da construç#o
1	Gasarmatur	Bloc gaz	Gruppo gas	GASVALVE "31" (KPL) WR-7KG	Automático de gás
2	Drosselgehäuse	Corps de limiteur de débit	Coperchio gas	Gashuiskep	Caixa de estrangulamento
3	Einstellschraube	Vis de réglage	Vite regolazione minimo	Intelschroef	Parafuso
4	O-Ring 10x2,5 (10x)	O-ring (10x)	Anello tenuta (10x)	O-ring (10 x)	O-ring (10x)
5	Kappe (10x)	Capot de protection (10x)	Sigillo (10x)	Beschermkap (10x)	Placa de fecho (10x)
6	Plombierdraht (10x)	Fil de plomb (10x)	Filo zincato (10x)	Verzegeldraad (10x)	Arame de selagem (10x)
7	Plombe (10x)	Plomb	Piombino (10x)	Loodje (10 x)	Selo de chumbo (10x)
8	Schraube (10x)	Vis (10x)	Vite (10x)	Schroef (10 x)	Parafuso (10x)
9	Dichtung (10x)	Joint (10x)	Guarnizione (10x)	Pakkingring (10 x)	Vedante (10x)
10	Druckfeder	Ressort	Molla antagonista	Gasklepveer	Mola
11	Druckfeder	Ressort	Molla antagonista	Gasklepveer	Mola
12	Gasventil (2E)	Soupape gaz (2E)	Valvola gas modul. (2E)	Gasklep binnenwerk	Válvula de gás (2E)
12	Gasventil (3E)	Soupape gaz (3E)	Valvola gas modul. (3E)	GASKLEP "3E" WR.KB/AME/KME "31"	Válvula de gás (3E)
13	Gasventil (2)	Soupape gaz (2)	Piattello della valvola (2)	Gasklepeenheid (2)	Conjunto de válvula (2)
13	Gasventil (3)	Soupape gaz (3)	Piattello della valvola (3)	GASKLEP	Conjunto de válvula (3)
14	Ventilstift	Tige du clapet	Perno valvola	Gasklepstift	Perno
15	O-ring (10x)	O-ring (10x)	Anello tenuta (10x)	O-ring (10 x)	O-ring (10x)
16	Gassieb (10x)	Filtre gaz (10x)	Filtro gas (10x)	Gaszeef (10 x)	Filtro de gás em rede (10x)
17	Dichtscheibe (10x)	Joint (10x)	Guarnizione (10x)	Pakkingring (10 x)	Anel de vedaç#o (10x)
18	Membranschalter	Interrupteur # membrane	Interruttore Membrana	Membraanschakelaar	Válvula de membrana
19	Servoventil	Servovalve	Elettrovalvola principale	Servo Gasklep	Servoválvula
20	Zündgasventil	T#te magnétique d'allumage	Elettrovalvola bruciatore pilota	Aansteek gasklep	Válvula de igniç#o
21	O-Ring (10x)	O-ring (10x)	Anello tenuta (10x)	O-ring (10 x)	O-ring (10x)
22	O-Ring (10x)	O-ring (10x)	Anello tenuta (10x)	O-ring (10 x)	O-ring (10x)
23	Schraube (10x)	Vis (10x)	Vite (10x)	schroef (10 x)	Parafuso (10x)
24	Dichtung (10x)	Joint (10x)	Guarnizione (10x)	Pakkingring (10 x)	Vedante (10x)
25	Verbindungsstück	Raccord	Raccordino	Tussenstuk	Tampa de aut. de gás
26	Blech	Tôle	Lamierino	Geleidingsplaat	Suporte de comandos
27	Gaszuführungsrohr	Tube arrivée gaz	Tubo gas	Gasleiding	Tubo condutor de gás
5A	Baugruppe	Groupe de construction	Gruppo di costruzione	Montagegroep	Elemento da construç#o
1	Wasserarmatur	Robinet d'eau	Gruppo acqua	WATERVALVE "PA" WR 350-1K-7KG Z/VENT	Automático de água
2	Deckel	Couvercle	Coperchio	Waterhuisdekssel	Tampa
3	Buchse	Douille	Buccola	Doorvoer + opdrukstift	Casquilho
4	O-Ring (10x)	O-ring (10x)	Anello tenuta (10x)	O-ring (10 x)	O-ring (10x)
5	Membrane (A)	Membrane (A)	Membrana (A)	Membraan	Membrana (A)
5	Membrane (B)	Membrane (B)	Membrana (B)	Membraan	Membrana (B)
5	Membrane (C)	Membrane (C)	Membrana (C)	Membraan	Membrana (C)
6	Buchse (10x)	Douille (10x)	Buccola (10x)	Huls (10 x)	Casquilho (10x)
7	Buchse	Douille	Buccola	Draadbus	Casquilho
8	O-Ring (10x)	O-ring (10x)	Anello tenuta (10x)	O-ring (10 x)	O-ring (10x)
9	Bügel (10x)	Epingle (10x)	Fermo a molla (10x)	Beugel (10 x)	Freio (10x)
10	Wassersieb (10x)	Filtre eau (10x)	Filtro acqua (10x)	Waterzeef (10 x)	Filtro de água (10x)
11	Wählerschraube	Vis de réglage	Selettore	Suppletiespindel	Selector de caudal
12	O-Ring (10x)	O-ring (10x)	Anello tenuta (10x)	O-ring (10 x)	O-ring (10x)
13	Schraube (10x)	Vis (10x)	Vite (10x)	Schroef (10 x)	Parafuso (10x)
14	Sicherungsscheibe (10x)	Circlips (10x)	Rondella (10x)	Borgveering (10 x)	Freio de fixaç#o (10x)
15	Druckplatte	Plaque d'appui	Staffa	Drukplaat	Placa de press#o
16	Spindel	Goupille	Perno	Regelschroef	Veio exc#ntrico

List of translations Übersetzungsliste		Liste des traductions Traduzione delle descrizioni		Vertalinglijst Lista das traduções	
Pos	Beschreibung	Denomination	Descrizione	Benaming	Descrि#o
17	Wassermengenregler	Regulateur de débit eau	Dosatore portata acqua	WATERDEBIETREGELAAR WR...1KD1P...S3695	Estabilizador de caudal
17	Wassermengenregler kompl.	Regulateur de débit eau	Dosatore portata acqua	Waterhoeveelheidsregelaar	Estabilizador de caudal
18	O-Ring (10x)	O-ring (10x)	Anello tenuta (10x)	O-ring (10 x)	O-ring (10x)
19	O-Ring (10x)	O-ring (10x)	Anello tenuta (10x)	O-ring (10 x)	O-ring (10x)
20	Schraube (10x)	Vis (10x)	Vite (10x)	Schroef (10 x)	Parafuso (10x)
21	Venturi (23 S)	Venturi (23S)	Venturi (23S)	Venturi	Venturi (23S)
22	O-Ring (10x)	O-ring (10x)	Anello tenuta (10x)	O-ring (10 x)	O-ring (10x)
5B	Baugruppe	Groupe de construction	Gruppo di costruzione	Montagegroep	Elemento da construç#o
1	Wasserarmatur	Robinet d'eau	Gruppo acqua	Waterdeel	Automático de água
2	Deckel	Couvercle	Coperchio	Deksel	Tampa de água
3	Stift (10x)	Goupille (10x)	Spina (10x)	Opdrukstift (10 x)	Pino (10x)
5	Schraube (10x)	Vis (10x)	Vite (10x)	Schroef (10x)	Parafuso (10x)
6	Langsamzündventil (E)	Vanne d'allumage progressif (E)	Valvolina lente accensione (E)	Langzaamontstekingsventiel (E)	Válvula de igniç#o lenta (E)
7	Dichtscheibe (10x)	Joint (10x)	Guarnizione (10x)	Pakkingring (10 x)	Anel de vedaç#o (10x)
8	Membrane (A)	Membrane (A)	Membrana (A)	Membraan	Membrana (A)
8	Membrane (B)	Membrane (B)	Membrana (B)	Membraan	Membrana (B)
8	Membrane (C)	Membrane (C)	Membrana (C)	Membraan	Membrana (C)
9	Buchse (10x)	Douille (10x)	Buccola (10x)	Huls (10 x)	Casquilho (10x)
10	Wassersieb	Filtre eau	Filtro acqua	Waterzeef	Filtro de água
11	Wählerschraube	Vis de réglage	Selettore	Spindel temperatuurkiezer	Selector de caudal
12	Buchse	Douille	Buccola	Huls	Casquilho
13	O-Ring (10x)	Joint torique (10x)	Anello tenuta (10x)	O-ring (10x)	O-ring (10x)
14	Spindel	Goupille	Perno	Spindel	Veio exc#ntrico
15	Schraube (10x)	Vis (10x)	Vite (10x)	Schroef (10x)	Parafuso (10x)
16	Sicherungsscheibe (10x)	Circlips (10x)	Rondella (10x)	Borgveering (10 x)	Freio de fixaç#o (10x)
17	Wassermengenregler	Regleur de débit eau	Regolatore portata	Waterhoeveelheidsregelaar	Estabilizador de caudal
18	O-Ring (10x)	Joint torique (10x)	Anello tenuta (10x)	O-ring (10x)	O-ring (10x)
19	Verschlußschraube	Vis de fermeture	Vite di chiusura	Afdekschroef	Parafuso de fecho
20	Verschlußschraube	Vis de fermeture	Vite di chiusura	Schroef	Parafuso de fecho
21	Venturi (13)	Venturi (13)	Venturi (13)	Venturi (13)	Venturi (13)
22	O-Ring (10x)	O-ring (10x)	Anello tenuta (10x)	O-ring (10 x)	O-ring (10x)
23	Zubehör Nr.434	Robinet # soupape	Accessorio N# 434	KRANENSTEL MESS.WATERDEEL	ACESSÓRIO NR.434
24	Drehgriffe	Croisillons	Manopola	Kraanknop set	Conjunto de manipulós
5C	Baugruppe	Groupe de construction	Gruppo di costruzione	Montagegroep	Elemento da construç#o
1	Wasserarmatur	Robinet d'eau	Gruppo acqua	Waterdeel	Automático de água
2	Deckel	Couvercle	Coperchio	Deksel	Tampa de água
3	Stift (10x)	Goupille (10x)	Spina (10x)	Opdrukstift (10 x)	Pino (10x)
5	Schraube (10x)	Vis (10x)	Vite (10x)	Schroef (10x)	Parafuso (10x)
6	Langsamzündventil (C)	Vanne d'allumage progressif (C)	Valvolina lente accensione (C)	Langzaamontstekingsventiel (C)	Válvula de igniç#o lenta (C)
7	Dichtscheibe (10x)	Joint (10x)	Guarnizione (10x)	Pakkingring (10 x)	Anel de vedaç#o (10x)
8	Membrane (A)	Membrane (A)	Membrana (A)	Membraan	Membrana (A)
9	Buchse (10x)	Douille (10x)	Buccola (10x)	Huls (10 x)	Casquilho (10x)
10	Wassersieb	Filtre eau	Filtro acqua	Waterzeef	Filtro de água
11	Wählerschraube	Vis de réglage	Selettore	Temperatuurkiezersschroef	Selector de caudal
12	O-Ring (10x)	Joint torique (10x)	Anello tenuta (10x)	O-ring (10x)	O-ring (10x)
13	Buchse	Douille	Buccola	Huls	Casquilho
14	Spindel	Goupille	Perno	Spindel	Veio exc#ntrico
15	Schraube (10x)	Vis (10x)	Vite (10x)	Schroef (10x)	Parafuso (10x)
16	Sicherungsscheibe (10x)	Circlips (10x)	Rondella (10x)	Borgveering (10 x)	Freio de fixaç#o (10x)
17	Verschlußschraube	Vis de fermeture	Vite di chiusura	Schroef	Parafuso de fecho
18	Wassermengenregler	Regleur de débit eau	Regolatore portata	Waterhoeveelheidsregelaar	Estabilizador de caudal
19	O-Ring (10x)	Joint torique (10x)	Anello tenuta (10x)	O-ring (10x)	O-ring (10x)
20	Venturi (13)	Venturi (13)	Venturi (13)	Venturi (13)	Venturi (13)
21	O-Ring (10x)	O-ring (10x)	Anello tenuta (10x)	O-ring (10 x)	O-ring (10x)
22	Zwischenstück (10x)	Entretoise (10x)	Flussostato (10x)	Verbindingsstuk	Peça intermédia (10x)
6	Baugruppe	Groupe de construction	Gruppo di costruzione	Montagegroep	Elemento da construç#o
1	Zündbaustein	Unité d'allumage	Centralina di accensione	Ontstekingstrafo	Unidade de igniç#o



Bosch Thermotechnik GmbH
Junkersstr. 20-24
D-73249 Wernau / Germany