

- EN INSTALLATION AND OPERATION MANUAL
- ES MANUAL DE INSTALACIÓN Y FUNCIONAMIENTO
- DE INSTALLATIONS- UND BETRIEBSHANDBUCH
- FR MANUEL D'INSTALLATION ET DE FONCTIONNEMENT
- IT MANUALE D'INSTALLAZIONE E D'USO

- PT MANUAL DE INSTALAÇÃO E DE FUNCIONAMENTO
- DA BRUGER- OG MONTERINGSVEJLEDNING
- NL INSTALLATIE- EN BEDIENINGSHANDLEIDING
- SV HANDBOK FÖR INSTALLATION OCH ANVÄNDING
- EL ΕΓΧΕΙΡΙΔΙΟ ΕΓΚΑΤΑΣΤΑΣΗΣ ΚΑΙ ΛΕΙΤΟΥΡΓΙΑΣ

# DX-Interface





Specifications in this manual are subject to change without notice in order that HITACHI may bring the latest innovations to their customers.

Whilst every effort is made to ensure that all specifications are correct, printing errors are beyond Hitachi's control; Hitachi cannot be held responsible for these errors.

Las especificaciones de este manual están sujetas a cambios sin previo aviso a fin de que HITACHI pueda ofrecer las últimas innovaciones a sus clientes.

A pesar de que se hacen todos los esfuerzos posibles para asegurarse de que las especificaciones sean correctas, los errores de impresión están fuera del control de HITACHI, a quien no se hará responsable de ellos.

Bei den technischen Angaben in diesem Handbuch sind Änderungen vorbehalten, damit HITACHI seinen Kunden die jeweils neuesten Innovationen präsentieren kann.

Sämtliche Anstrengungen wurden unternommen, um sicherzustellen, dass alle technischen Informationen ohne Fehler veröffentlicht worden sind. Für Druckfehler kann HITACHI jedoch keine Verantwortung übernehmen, da sie außerhalb ihrer Kontrolle liegen.

Les caractéristiques publiées dans ce manuel peuvent être modifiées sans préavis, HITACHI souhaitant pouvoir toujours offrir à ses clients les dernières innovations.

Bien que tous les efforts sont faits pour assurer l'exactitude des caractéristiques, les erreurs d'impression sont hors du contrôle de HITACHI qui ne pourrait en être tenu responsable.

Le specifiche di questo manuale sono soggette a modifica senza preavviso affinché HITACHI possa offrire ai propri clienti le ultime novità.

Sebbene sia stata posta la massima cura nel garantire la correttezza dei dati, HITACHI non è responsabile per eventuali errori di stampa che esulano dal proprio controllo.

As especificações apresentadas neste manual estão sujeitas a alterações sem aviso prévio, de modo a que a HITACHI possa oferecer aos seus clientes, da forma mais expedita possível, as inovações mais recentes.

Apesar de serem feitos todos os esforços para assegurar que todas as especificações apresentadas são correctas, quaisquer erros de impressão estão fora do controlo da HITACHI, que não pode ser responsabilizada por estes erros eventuais.

Specifikationerne i denne vejledning kan ændres uden varsel, for at HITACHI kan bringe de nyeste innovationer ud til kunderne. På trods af alle anstrengelser for at sikre at alle specifikationerne er korrekte, har Hitachi ikke kontrol over trykfejl, og Hitachi kan ikke holdes ansvarlig herfor.

De specificaties in deze handleiding kunnen worden gewijzigd zonder verdere kennisgeving zodat HITACHI zijn klanten kan voorzien van de nieuwste innovaties.

Iedere poging wordt ondernomen om te zorgen dat alle specificaties juist zijn. Voorkomende drukfouten kunnen echter niet door Hitachi worden gecontroleerd, waardoor Hitachi niet aansprakelijk kan worden gesteld voor deze fouten.

Specifikationerna i den här handboken kan ändras utan föregående meddelande för att HITACHI ska kunna leverera de senaste innovationerna till kunderna.

Vi på Hitachi gör allt vi kan för att se till att alla specifikationer stämmer, men vi har ingen kontroll över tryckfel och kan därför inte hållas ansvariga för den typen av fel.

Οι προδιαγραφές του εγχειριδίου μπορούν να αλλάξουν χωρίς προειδοποίηση, προκειμένου η HITACHI να παρέχει τις τελευταίες καινοτομίες στους πελάτες της.

Αν και έχει γίνει κάθε προσπάθεια προκειμένου να εξασφαλιστεί ότι οι προδιαγραφές είναι σωστές, η Hitachi δεν μπορεί να ελέγξει τα τυπογραφικά λάθη και, ως εκ τούτου, δεν φέρει καμία ευθύνη για αυτά τα λάθη.



**▲ ATTENTION:**

This product shall not be mixed with general house waste at the end of its life and it shall be retired according to the appropriated local or national regulations in a environmentally correct way.

Due to the refrigerant, oil and other components contained in Air Conditioner, its dismantling must be done by a professional installer according to the applicable regulations.

Contact to the corresponding authorities for more information.

**▲ ATENCIÓN:**

Este producto no se debe eliminar con la basura doméstica al final de su vida útil y se debe desechar de manera respetuosa con el medio ambiente de acuerdo con los reglamentos locales o nacionales aplicables.

Debido al refrigerante, el aceite y otros componentes contenidos en el sistema de aire acondicionado, su desmontaje debe realizarlo un instalador profesional de acuerdo con la normativa aplicable.

Para obtener más información, póngase en contacto con las autoridades competentes.

**▲ ACHTUNG:**

Dass Ihr Produkt am Ende seiner Betriebsdauer nicht in den allgemeinen Hausmüll geworfen werden darf, sondern entsprechend den geltenden örtlichen und nationalen Bestimmungen auf umweltfreundliche Weise entsorgt werden muss.

Aufgrund des Kältemittels, des Öls und anderer in der Klimaanlage enthaltener Komponenten muss die Demontage von einem Fachmann entsprechend den geltenden Vorschriften durchgeführt werden.

Für weitere Informationen setzen Sie sich bitte mit den entsprechenden Behörden in Verbindung.

**▲ ATTENTION:**

Ne doit pas être mélangé aux ordures ménagères ordinaires à la fin de sa vie utile et qu'il doit être éliminé conformément à la réglementation locale ou nationale, dans le plus strict respect de l'environnement.

En raison du frigorigène, de l'huile et des autres composants que le climatiseur contient, son démontage doit être réalisé par un installateur professionnel conformément aux réglementations en vigueur.

**▲ ATTENZIONE:**

Indicazioni per il corretto smaltimento del prodotto ai sensi della Direttiva Europea 2002/96/EC e Dlgs 25 luglio 2005 n. 151

Il simbolo del cassonetto barrato riportato sull'apparecchiatura indica che il prodotto alla fine della propria vita utile deve essere raccolto separatamente dagli altri rifiuti.

L'utente dovrà, pertanto, conferire l'apparecchiatura giunta a fine vita agli idonei centri di raccolta differenziata dei rifiuti elettronici ed elettrotecnici, oppure riconsegnarla al rivenditore al momento dell'acquisto di una nuova apparecchiatura di tipo equivalente.

L'adeguata raccolta differenziata delle apparecchiature dismesse, per il loro avvio al riciclaggio, al trattamento ed allo smaltimento ambientalmente compatibile, contribuisce ad evitare possibili effetti negativi sull'ambiente e sulla salute e favorisce il ciclo dei materiali di cui è composta l'apparecchiatura.

Non tentate di smontare il sistema o l'unità da soli poiché ciò potrebbe causare effetti dannosi sulla vostra salute o sull'ambiente.

Vogliate contattare l'installatore, il rivenditore, o le autorità locali per ulteriori informazioni.

Lo smaltimento abusivo del prodotto da parte dell'utente può comportare l'applicazione delle sanzioni amministrative di cui all'articolo 50 e seguenti del D.Lgs. n. 22/1997.

**▲ ATENÇÃO:**

O seu produto não deve ser misturado com os desperdícios domésticos de carácter geral no final da sua duração e que deve ser eliminado de acordo com os regulamentos locais ou nacionais adequados de uma forma correcta para o meio ambiente.

Devido ao refrigerante, ao óleo e a outros componentes contidos no Ar condicionado, a desmontagem deve ser realizada por um instalador profissional de acordo com os regulamentos aplicáveis.

Contacte as autoridades correspondentes para obter mais informações.

**▲ BEMÆRK:**

At produktet ikke må smides ud sammen med almindeligt husholdningsaffald, men skal bortskaffes i overensstemmelse med de gældende lokale eller nationale regler på en miljømæssig korrekt måde.

Da klimaanlægget indeholder kølemiddel, olie samt andre komponenter, skal afmontering foretages af en fagmand i overensstemmelse med de gældende bestemmelser.

Kontakt de pågældende myndigheder for at få yderligere oplysninger.

**▲ ATTENTIE:**

Dit houdt in dat uw product niet wordt gemengd met gewoon huisvuil wanneer u het weg doet en dat het wordt gescheiden op een milieuvriendelijke manier volgens de geldige plaatselijke en landelijke reguleringen.

Vanwege het koelmiddel, de olie en andere onderdelen in de airconditioner moet het apparaat volgens de geldige regulering door een professionele installateur uit elkaar gehaald worden.

Neem contact op met de betreffende overheidsdienst voor meer informatie.

**▲ OBS!**

Det innebär att produkten inte ska slängas tillsammans med vanligt hushållsavfall utan kasseras på ett miljövänligt sätt i enlighet med gällande lokal eller nationell lagstiftning.

Luftkonditioneringsaggregatet innehåller kylmedium, olja och andra komponenter, vilket gör att det måste demonteras av en fackman i enlighet med tillämpliga regelverk.

Ta kontakt med ansvarig myndighet om du vill ha mer information.

**▲ ΠΡΟΣΟΧΗ:**

Σημαίνει ότι το προϊόν δεν θα πρέπει να αναμιχθεί με τα διάφορα οικιακά απορρίμματα στο τέλος του κύκλου ζωής του και θα πρέπει να αποσυρθεί σύμφωνα με τους κατάλληλους τοπικούς ή εθνικούς κανονισμούς και με τρόπο φιλικό προς το περιβάλλον.

Λόγω του ψυκτικού, του λαδιού και άλλων στοιχείων που περιέχονται στο κλιματιστικό, η αποσυναρμολόγησή του πρέπει να γίνει από επαγγελματία τεχνικό και σύμφωνα με τους ισχύοντες κανονισμούς.

Για περισσότερες λεπτομέρειες, επικοινωνήστε με τις αντίστοιχες αρχές.



### **English**

From 4th July 2007 and following Regulation EC N° 842/2006 on Certain Fluorinated Greenhouse gases, it is mandatory to fill in the label attached to the unit with the total amount of refrigerant charged on the installation.

Do not vent R410A/R407C into the atmosphere: R410A & R407C are fluorinated greenhouse gases covered by the Kyoto protocol global warming potential (GWP) R410A/R407C: = 1975/1652.5.

### **Español**

Desde el 4 de Julio de 2007 y en base al Reglamento CE N° 842/2006 sobre determinados gases fluorados de efecto invernadero, es obligatorio rellenar la etiqueta suministrada con la unidad con la cantidad total de refrigerante con que se ha cargado la instalación.

No descargue el R410A/R407C en la atmósfera: R410A y R407C son gases fluorados cubiertos por el protocolo de Kyoto con un potencial de calentamiento global (GWP): = 1975/1652.5.

### **Deutsch**

Ab 4. Juli 2007 und folgende Verordnung EG Nr. 842/2006 Bestimmte fluorierte Treibhausgase, auf dem Schild, das sich am Gerät befindet, muss die Gesamtkältemittelmenge verzeichnet sein, die bei der Installation eingefüllt wird.

Lassen sie R410A/R407C nicht in die luft entweichen: R410A & R407C sind fluorierte treibhausgase, die durch das Kyoto-protokoll erfasst sind. Sie besitzen folgendes treibhauspotential (GWP) R410A/R407C: = 1975/1652.5.

### **France:**

Du 4 Juillet 2007 et en fonction de la Réglementation CE N° 842/2006 concernant certains gaz à effet de serre fluorés, il est obligatoire de remplir l'étiquette attachée à l'unité en indiquant la quantité de fluide frigorigène qui a été chargée à l'installation.

Ne laissez pas le R410A/R407C se répandre dans l'atmosphère: le R410A et le R407C sont des gaz à effet de serre fluorés, couverts par le protocole de Kyoto avec un potentiel de réchauffement global (PRG) R410A/R407C: = 1975/1652.5.

### **Italiano**

Dal 4 Luglio 2007 e in base alla Normativa EC N° 842/2006 su determinati gas fluorurati ad effetto serra, è obbligatorio compilare l'etichetta che si trova sull'unità inserendo la quantità totale di refrigerante caricato nell'installazione.

Non scaricare R410A/R407C nell'atmosfera: R410A e R407C sono gas fluorurati ad effetto serra che in base al protocollo di Kyoto presentano un potenziale riscaldamento globale (GWP) R410A/R407C: = 1975/1652.5.

### **Português**

A partir de 4 de Julho de 2007 e em conformidade com a Regulamentação da UE N° 842/2006 sobre determinados gases fluorados com efeito de estufa, é obrigatório preencher a etiqueta afixada na unidade com a quantidade total de refrigerante carregada na instalação.

Não ventilar R410A/R407C para a atmosfera: o R410A e o R407C são gases fluorados com efeito de estufa abrangidos pelo potencial de aquecimento global (GWP) do protocolo de Quioto: = 1975/1652.5.

### **Dansk**

Fra d. 4. Juli 2007 og i henhold til Rådets forordning (EF) nr. 842/2006 om visse fluorholdige drivhusgasser, skal installationens samlede mængde kølevæske fremgå af den etiket, der er klæbet fast på enheden.

Slip ikke R410A/R407C ud i atmosfæren: R410 & R407C er fluorholdige drivhus-gasser, der er omfattet af Kyoto-protokollens globale opvarmningspotentiale (GWP) R410A/R407C: = 1975/1652.5.

### **Nederlands**

Vanaf 4 Juli 2007 en conform richtlijn EC N° 842/2006 voor bepaalde fluorbroeikasgassen, dient u de tabel in te vullen op de unit met het totale koelmiddelvolume in de installatie.

Laat geen R410A/R407C ontsnappen in de atmosfeer: R410A & R407C zijn fluorbroeikasgassen die vallen onder het protocol van Kyoto inzake klimaatverandering global warming potential (GWP) R410A/R407C: = 1975/1652.5.

### **Svenska**

Från och med 4 Juli 2007 och enligt reglering EC N° 842/2006 om vissa fluorhaltiga växthusgaser, måste etiketten som sitter på enheten fyllas i med sammanlagd mängd kylmedium som fyllts på under installationen.

Släpp inte ut R410A/R407C i atmosfären: R410A & R407C är fluorhaltiga växthus-gaser som omfattas av Kyotoprotokollet om global uppvärmnings-potential (GWP) R410/R407C: = 1975/1652.5.

### **Ελληνικά**

Από τις 4 Ιουλίου 2007 και σύμφωνα με τον Κανονισμό 842/2006/EK για για ορισμένα φθοριούχα αέρια θερμοκηπίου, είναι υποχρεωτική η συμπλήρωση της επισήμανσης που επισυνάπτεται στη μονάδα με το συνολικό ποσό ψυκτικού που εισήχθη κατά την εγκατάσταση.

Μην απελευθερώνετε R410A/R407C στην ατμοσφαιρα τα R410A & R407C είναι φθοριουχα αερια του θερμοκηπιου που εμπιπτουν στο πρωτοκολλο του κυοτο δυναμικο θερμανσησ του πλανητη (GWP) R410A/R407C: = 1975/1652.5

## INDEX

1. GENERAL INFORMATION
2. SAFETY
3. SYSTEM DESCRIPTION
4. PRODUCT GUIDE
5. NAME OF PARTS
6. COMBINABILITY
7. UNIT INSTALLATION
8. REFRIGERANT PIPING
9. ELECTRICAL WIRING

## INDICE

1. INFORMACIÓN GENERAL
2. SEGURIDAD
3. DESCRIPCIÓN DEL SISTEMA
4. GUÍA DEL PRODUCTO
5. NOMBRES DE LAS PIEZAS
6. CAPACIDAD DE COMBINACIÓN
7. INSTALACIÓN DE LA UNIDAD
8. TUBERÍA DE REFRIGERANTE
9. CABLEADO ELÉCTRICO

## INHALT

1. ALLGEMEINE INFORMATIONEN
2. SICHERHEIT
3. SYSTEMBESCHREIBUNG
4. PRODUKTÜBERSICHT
5. TEILEBEZEICHNUNG
6. MÖGLICHE KOMBINATIONEN
7. GERÄTEINSTALLATION
8. KÄLTEMITTELEITUNGEN
9. VERKABELUNG

## INDEX

1. INFORMATIONS GÉNÉRALES
2. SÉCURITÉ
3. DESCRIPTION DU SYSTÈME
4. GUIDE DU PRODUIT
5. NOMENCLATURE DES PIÈCES
6. POSSIBILITÉS DE COMBINAISONS
7. INSTALLATION DES UNITES
8. TUYAUTERIE FRIGORIFIQUE
9. CÂBLAGE ÉLECTRIQUE

## INDICE

1. INFORMAZIONI GENERALI
2. SICUREZZA
3. DESCRIZIONE DEL SISTEMA
4. GUIDA DEL PRODOTTO
5. NOMENCLATURA DEI COMPONENTI
6. COMBINABILITÀ
7. INSTALLAZIONE DELL'UNITÀ
8. LINEA REFRIGERANTE
9. COLLEGAMENTO DELLO SCHEMA ELETTRICO

## ÍNDICE

1. INFORMAÇÃO GERAL
2. SEGURANÇA
3. DESCRIÇÃO DO SISTEMA
4. GUIA DO PRODUTO
5. NOME DAS PEÇAS
6. COMBINAÇÕES
7. INSTALAÇÃO DA UNIDADE
8. TUBAGEM DE REFRIGERANTE
9. LIGAÇÕES ELÉTRICAS

## INDEX

1. GENEREL INFORMATION
2. SIKKERHED
3. SYSTEM BESKRIVELSE
4. PRODUKTVEJLEDNING
5. NAVN PÅ DELE
6. FORENELIGHED
7. MONTERING AF ENHED
8. RØRFØRING FOR KØLEMIDDEL
9. ELEKTRISK LEDNINGSFØRING

## INHOUDSOPGAVE

1. ALGEMENE INFORMATIE
2. VEILIGHEID
3. BESCHRIJVING VAN HET SYSTEEM
4. PRODUCTGIDS
5. NAMEN VAN ONDERDELEN
6. COMBINATIEOPTIES
7. INSTALLATIE VAN DE UNIT
8. KOELLEIDINGEN
9. ELEKTRISCHE BEDRADING

## INNEHÅLLSFÖRTECKNING

1. ALLMÄN INFORMATION
2. SÄKERHET
3. SYSTEMÖVERSIKT
4. PRODUKTGUIDE
5. DELARNAS NAMN
6. KOMBINATIONSMÖJLIGHETER
7. INSTALLATION AV ENHET
8. KYLRÖR
9. KABELANSLUTNINGAR

## ΕΥΡΕΤΗΡΙΟ

1. ΓΕΝΙΚΕΣ ΠΛΗΡΟΦΟΡΙΕΣ
2. ΑΦΑΛΕΙΑ
3. ΠΕΡΙΓΡΑΦΗ ΤΟΥ ΣΥΣΤΗΜΑΤΟΣ
4. ΟΔΗΓΟΣ ΠΡΟΪΟΝΤΟΣ
5. ΟΝΟΜΑΤΑ ΕΞΑΡΤΗΜΑΤΩΝ
6. ΣΥΝΔΥΑΣΜΙΚΟΤΗΤΑ
7. ΕΓΚΑΤΑΣΤΑΣΗ ΜΟΝΑΔΩΝ
8. ΣΩΛΗΝΩΣΕΙΣ ΨΥΚΤΙΚΟΥ
9. ΗΛΕΚΤΡΙΚΗ ΚΑΛΩΔΙΩΣΗ

## 1 GENERAL INFORMATION

No part of this publication may be reproduced, copied, filed or transmitted in any shape or form without the permission of HITACHI.

Within the policy of continuous improvement of its products, HITACHI reserves the right to make changes at any time without prior notification and without being compelled to introducing them into products subsequently sold. This document may therefore have been subject to amendments during the life of the product.

HITACHI makes every effort to offer correct, up-to-date documentation. Despite this, printing errors cannot be controlled by HITACHI and are not its responsibility.

As a result, some of the images or data used to illustrate this document may not refer to specific models. No claims will be accepted based on the data, illustrations and descriptions included in this manual.

No type of modification must be made to the equipment without prior, written authorisation from the manufacturer.

## 2 SAFETY

### 2.1 APPLIED SYMBOLS

During normal air conditioning system design work or unit installation, greater attention must be paid in certain situations requiring particular care in order to avoid damage to the unit, the installation or the building or property.

Situations that jeopardise the safety of those in the surrounding area or that put the unit itself at risk will be clearly indicated in this manual.

To indicate these situations, a series of special symbols will be used to clearly identify these situations.

Pay close attention to these symbols and to the messages following them, as your safety and that of others depends on it.



#### DANGER

- *The text following this symbol contains information and instructions relating directly to your safety and physical wellbeing.*
- *Not taking these instructions into account could lead to serious, very serious or even fatal injuries to you and others in the proximities of the unit.*

In the texts following the danger symbol you can also find information on safe procedures during unit installation.



#### CAUTION

- *The text following this symbol contains information and instructions relating directly to your safety and physical wellbeing.*
- *Not taking these instructions into account could lead to minor injuries to you and others in the proximities of the unit.*
- *Not taking these instructions into account could lead to unit damage.*

In the texts following the caution symbol you can also find information on safe procedures during unit installation.



#### NOTE

- *The text following this symbol contains information or instructions that may be of use or that require a more thorough explanation.*
- *Instructions regarding inspections to be made on unit parts or systems may also be included.*



## 2.2 ADDITIONAL INFORMATION ABOUT SAFETY



### DANGER

- **HITACHI is not able to foresee all the circumstances which may result in a potential danger.**
- **Do not pour water in the indoor or outdoor unit. These products are fitted with electric components. If water comes into contact with electric components, this will cause a serious electric shock.**
- **Do not handle or adjust the safety devices inside the indoor and outdoor units. The handling or adjustment of these devices may result in serious accident.**
- **Do not open the service cover or access panel of the indoor and outdoor units without disconnecting the main supply.**
- **In the event of fire, switch off the mains, put out the fire immediately and contact your service supplier.**
- **Check that the earth cable is correctly connected.**
- **Connect the unit to a circuit breaker of the specified capacity.**



### CAUTION

- **Refrigerant leaks may hinder respiration as the gas displaces the air in the room.**

- **Fit the indoor unit, the outdoor unit, the remote control and the cable at a minimum of 3 metres away from sources of strong radiation from electromagnetic waves, such as medical equipment.**
- **Do not use sprays, such as insecticides, varnishes or enamels or any other inflammable gas within a metre of the system.**
- **If the circuit breaker or supply fuse of the unit comes on frequently, stop the system and contact the service supplier.**
- **Do not carry out maintenance or inspection work yourself. This work must be carried out by qualified service personnel with suitable tools and resources for the work.**
- **Do not place any foreign material (branches, sticks, etc.) in the air inlet or outlet of the unit. These units are fitted with high speed fans and contact with any object is dangerous.**
- **This appliance must be used only by adult and capable people, having received the technical information or instructions to handle this appliance properly and safely.**
- **Children should be supervised to ensure that they do not play with the appliance.**



### NOTE

- **The air in the room should be renewed and the room ventilated every 3 or 4 hours.**
- **The system fitter and specialist shall provide anti-leak safety in accordance with local regulations.**

## 2.3 PURPOSE OF THIS MANUAL

This air conditioning system has been exclusively designed to supply air conditioning to people in one or more rooms within the installation range of the system.

The air conditioning system must not be used for other purpose such as drying clothes, cooling food or any other process requiring cooling or heating.

The air conditioning system should only be installed by qualified personnel, with the necessary resources, tools and equipment, who are familiar with the safety procedures required to successfully carry out the installation.

**PLEASE READ AND FAMILIARISE YOURSELF WITH THE MANUAL BEFORE STARTING WORK ON THE INSTALLATION OF THE AIR CONDITIONING SYSTEM.** Failure to observe the instructions for installation, use and operation described in this Manual may result in operating failure including potentially serious faults, or even the destruction of the air conditioning system.

It is assumed that the air conditioning system will be installed and maintained by responsible personnel trained for the purpose. If this is not the case, the customer should include all the safety, caution and operating signs in the native language of the personnel responsible.

Do not install the unit in the following places, as this may lead to a fire, deformities, rusting or faults:

- Places where oil is present (including oil for machinery).
- Places with a high concentration of sulphurous gas, such as spas.
- Places where flammable gases may be generated or circulate.
- Places with a saline, acidic or alkaline atmosphere.

Do not install the unit in places where silicon gas is present. Any silicon gas deposited on the surface of the heat exchanger will repel water. As a result, the condensate water will splash out of the collection tray and into the electrical box. Water leaks or electrical faults may eventually be caused.

Do not install the unit in a place where the current of expelled air directly affects animals or plants as they could be adversely affected.

## 3 SYSTEM DESCRIPTION

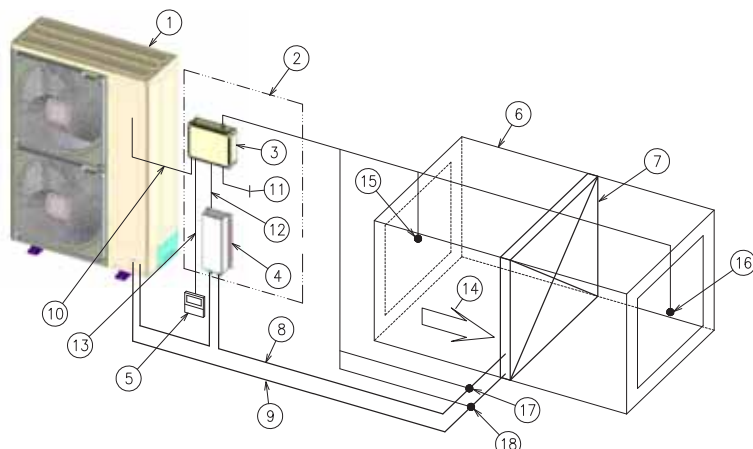

Item	Description
1	Hitachi outdoor unit RAS-H(V)RN(M/S)(1/2)E
2	DX-Interface EXV-(2.0-10.0)E
3	Control box
4	Expansion valve box
5	Remote controller (PC-ART)
6	Unit or device with heat exchanger
7	DX- heat exchanger
8	Liquid line
9	Gas line
10	Outdoor - Indoor communication
11	Power supply
12	Expansion valve control communication
13	Remote controller communication
14	Air flow direction
15	Inlet thermistor
16	Outlet thermistor
17	Liquid pipe thermistor
18	Gas pipe thermistor

**CAUTION**

- The installation distance between the Dx-Interface and the device with heat exchanger must be the shortest possible.
- Keep the distance between the unit or device with heat exchanger and the expansion valve box for the piping length up to 5m. Also the elevation difference between the unit or device with heat exchanger and the expansion valve box must be no more than 2m.
- Make sure that the installation distance between the control box and the unit or device with heat exchanger is short enough that the thermistors sensing are not distorted.
- The thermistor cable should never be installed in the same ducting as power or control cables.

## 4 PRODUCT GUIDE

## 4.1 CLASSIFICATION OF DX-INTERFACE

DX-Interface type			
Position-separating hyphen (fixed)			
Capacity (HP): 2.0, 2.5, 3.0, 4.0, 5.0, 6.0, 8.0, 10.0			
E = Made in Europe			
EXV	-	X.X	E

## 4.2 PRODUCT GUIDE CODIFICATION





DX-Interface	
Model	Code
EXV-2.0E	7E619900
EXV-2.5E	7E619901
EXV-3.0E	7E619902
EXV-4.0E	7E619903
EXV-5.0E	7E619904
EXV-6.0E	7E619905
EXV-8.0E	7E619906
EXV-10.0E	7E619907

### 4.3 FACTORY-SUPPLIED

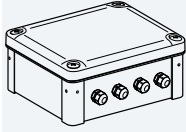
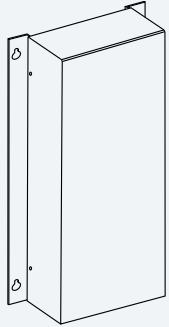
Check the content and the number of accessories in the package. The package contains the following parts:

Name description	Appearance	Qty	Purpose
Control box		1	System control box
Expansion valve box		1	Expansion valve for refrigerant cycle control

Name description	Appearance	Qty	Purpose
Thermistor		4	Temperature sensing: Inlet air (blue) outlet air (red) gas line (yellow) liquid line (black)
Installation Manual and Declaration of Conformity		1	Instructions and important notice
Control box fixing accessory		4	Control box cover lock

### 5 NAME OF PARTS

#### ◆ DX-Interface EXV-(2.0-6.0)E

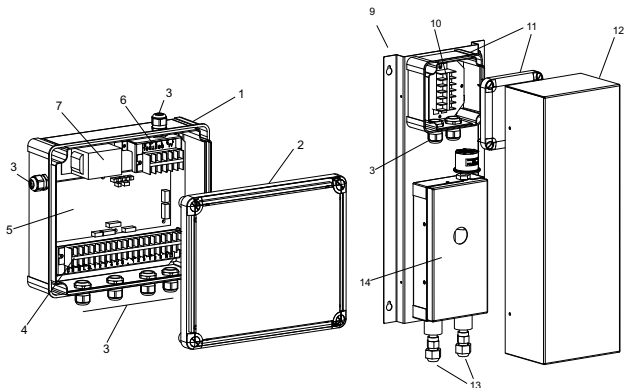

#### ◆ DX-Interface EXV-(8.0/10.0)E

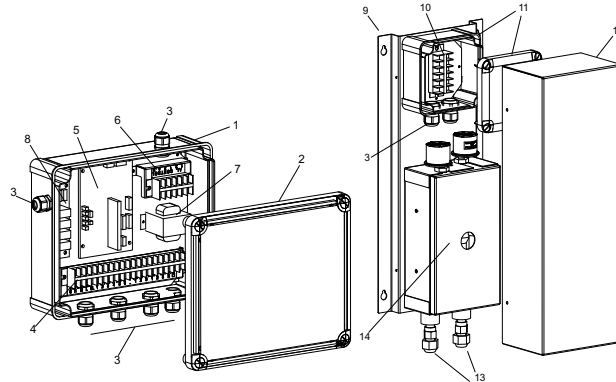

N°	Name	N°	Name
1	Control box	8	PCB2
2	Control box cover	9	Expansion valve box
3	Cable gland	10	Terminal board 3
4	Terminal board 1	11	Terminal board box and cover
5	PCB1	12	Expansion valve box cover
6	Terminal board 2	13	Refrigerant connections
7	Transformer	14	Expansion valve device

## 6 COMBINABILITY

Outdoor Unit	DX -Code	Allowed Heat Exchanger Capacity (kW) <sup>(1)</sup>			Heat Exchanger Volume (dm <sup>3</sup> ) <sup>(1)</sup>		
		Mode	Min	Nom	Max	Min	Max
RAS-2HVRN2	EXV-2.0E	Cooling	4.0	5.0	5.6	0.57	1.16
		Heating	4.5	5.6	7.1		
RAS-2.5HVRN2	EXV-2.5E	Cooling	4.8	6.0	6.3	0.89	1.35
		Heating	5.6	7.0	7.1		
RAS-3HVRNS2 RAS-3HVRNM2E	EXV-3.0E	Cooling	5.7	7.1	8.0	1.03	1.57
		Heating	6.4	8.0	9.0		
RAS-4H(V)RNS2E RAS-4H(V)RNM2E	EXV-4.0E	Cooling	8.0	10.0	11.2	1.51	2.37
		Heating	9.0	11.2	12.5		
RAS-5H(V)RNS2E RAS-5H(V)RNM2E	EXV-5.0E	Cooling	10.0	12.5	14.0	1.92	2.37
		Heating	11.2	14.0	16.0		
RAS-6H(V)RNS2E RAS-6H(V)RNM2E	EXV-6.0E	Cooling	11.2	14.0	16.0	1.92	2.92
		Heating	12.8	16.0	18.0		
RAS-8HRNSE RAS-8HRNM	EXV-8.0E	Cooling	16.0	20.0	22.4	2.92	3.89
		Heating	17.9	22.4	25.0		
RAS-10HRNSE RAS-10HRNM	EXV-10.0E	Cooling	20.0	25.0	28.0	3.89	4.76
		Heating	22.4	28.0	31.5		

<sup>(1)</sup> cooling and heating capacity data is based on the following indoor and outdoor temperature conditions, according standard EN14511

Operation conditions		Cooling	Heating
Indoor air inlet temperature	DB	27.0 °C	20.0 °C
	WB	19.0 °C	—
Outdoor air inlet temperature	DB	35.0 °C	7.0 °C
	WB	—	6.0 °C

DB: dry bulb; WB: wet bulb  
Pipe length: 7.5 m; pipe height: 0 m.



## NOTE

- Check the AHU's or connected device with the Dx- heat exchanger allow operating mode and use it exclusively in the proper mode.
- Please refer to Outdoor and AHU or unit device with heat exchanger Installation Manual and Technical Catalogue for the working range limits.

## 7 UNIT INSTALLATION

- Do not install the DX-Interface where electromagnetic wave is directly radiated to the control box or expansion valve box.
  - Install a noise filter when noise is emitted from the power supply.
  - Do not install the DX-Interface where generation, flowing, staying or leakage of flammable gas may occur.
  - When the false ceiling contains high humidity, dew condensation water may occur on the outer surface of the expansion valve box. Therefore utilize the insulation on the outer surface of the expansion valve box.
- ◆ **Installation Location**
- 1 Installation methods are selectable according to the dimension of the false ceiling.
  - 2 Keep the distance between the unit or device with heat exchanger and the expansion valve box for the piping length up to 5m. Also the elevation difference between the unit or device with heat exchanger and the expansion valve box must be no more than 2m.
  - 3 Check the ceiling slab is strong enough. If the ceiling slab is too weak to support the weight of the expansion valve box, noise and vibration may occur.
  - 4 Secure proper space around the control box and expansion valve box for operation and maintenance work. Also a service access door should be prepared in order to remove the DX-Interface without getting rid of the ceiling plate.
  - 5 Select a suitable and convenient location for the refrigerant piping connection.
  - 6 Do not install the DX-Interface in a kitchen where vapor or mist flows. Dew condensation water may occur on the expansion valve box while cooling operation. In this case, utilize the insulation.
  - 7 Do not install the DX-Interface in a organic solvent (thinner or benzene) environment. Synthetic resin parts may dissolve.
  - 8 Do not install the DX-Interface where generation, flowing or staying of flammable gas may occur.
  - 9 The sound of refrigerant running through from the expansion valve box may be heard. Therefore install the expansion valve box where the sound will not leak such as in the false ceiling of a hall way.
  - 10 Use ceiling material with sound-proof such as plaster board.

### 7.1 DIMENSIONAL DATA

◆ DX-Interface EXV-(2.0-6.0)E / DX-Interface EXV-(8.0/10.0)E  
(mm)

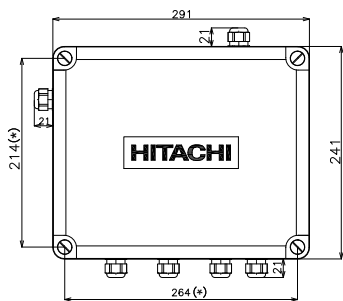

(\*) For installation

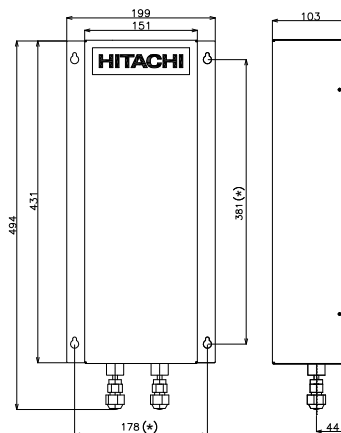

### 7.2 SERVICE SPACE

◆ DX-Interface EXV-(2.0-6.0)E / DX-Interface EXV-(8.0/10.0)E  
Minimum sizes (mm)

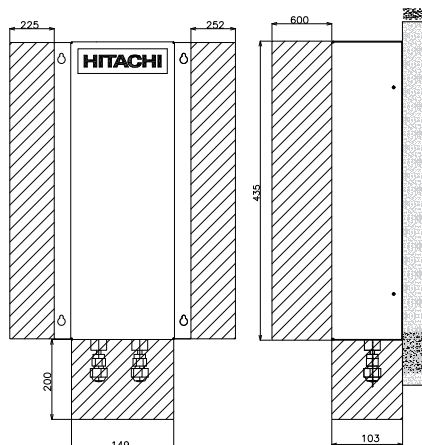
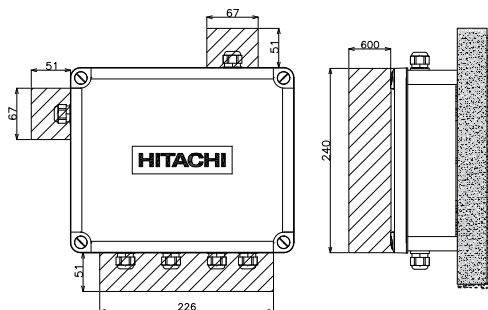

### 7.3 MOUNTING METHOD

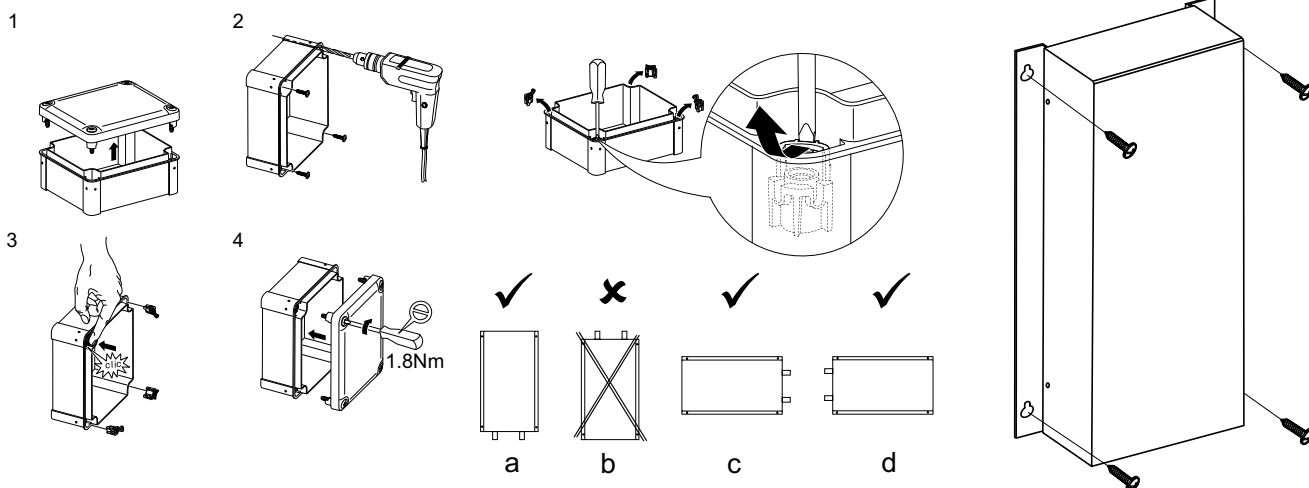

**i** NOTE

In case of installation positions "c" and "d", make sure to insulate the copper pipes inlet on the expansion valve box cover to avoid any liquid filtration and accumulation.

## 7.4 THERMISTOR INSTALLATION

### ◆ Liquid and gas pipes thermistors

Two type thermistors are supplied inside the control box. The purpose and identification of each one is as follow:

Item	PCB socket / Thermistor connector color	PCB socket number	Thermistor length (mm)
Liquid pipe thermistor	Black	THM 3	650
Gas pipe thermistor	Yellow	THM 5	600

### ⚠ CAUTION

*In case that the thermistors supplied with the Dx-Interface are not long enough, please make sure that the length extension is properly done avoiding the sensing distortion and that the joint is properly insulated to avoid any electrical failure.*

### i NOTE

*When fitting the thermistors, remember that they must be secured correctly by the special clamp, ensuring the perfect contact between the pipe and thermistor. Cover it completely with insulation, like cork tape or pipe insulation, depending on the location. Replace them if damaged during maintenance work.*

### Thermistor installation example

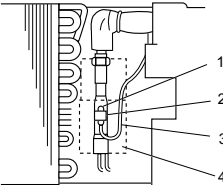
1	Liquid / gas pipe thermistor (factory supplied)	
2	Thermistor holder (field supplied)	
3	Thermistor lead wire (field supplied)	
4	Insulation (field supplied)	

### ⚠ CAUTION

*The thermistor must be installed properly in order to avoid water onto the thermistor.*

### Typical installation location

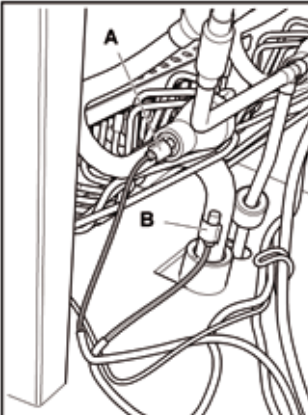
A	Liquid pipe thermistor	Must be installed in the coldest liquid line point in the heat exchanger (prior the distributor).	
B	Gas pipe thermistor	Must be installed as close as possible to the heat exchanger refrigerant outlet.	

### ◆ Air thermistor

Two air thermistors are supplied inside the control box. The purpose and identification of each one is as follow:

Item	PCB socket / Thermistor connector color	PCB socket number	Thermistor length (mm)
Inlet air thermistor	Blue	THM 1	1200
Outlet air thermistor	Red	THM 2	1200

### ⚠ CAUTION

*In case that the thermistors supplied with the Dx-Interface are not long enough, please make sure that the length extension is properly done avoiding the sensing distortion and that the joint is properly insulated to avoid any electrical failure.*

### i NOTE

*When fitting the air thermistor, remember that they must be secure correctly, in an adequate place to avoid external influences, like ambient conditions, and where the air temperature is significant.*

### Cable clamp example

1	Tie (Field supplied)
2	Cable clamp (Field supplied)
3	Thermistor (supplied)

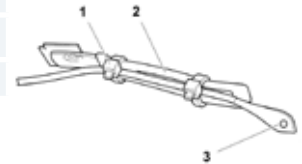

### ⚠ CAUTION

*The thermistor must be installed properly in order to avoid water onto the thermistor.*

### Typical installation

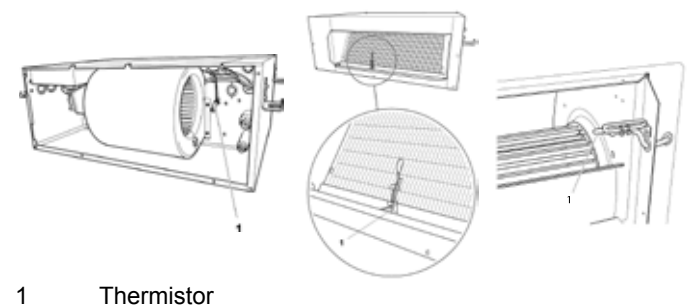

## 8 REFRIGERANT PIPING

### 8.1 GENERAL NOTES BEFORE PERFORMING PIPE WORK

- 1 Prepare locally-supplied copper pipes.
- 2 Select the piping size with the correct thickness and correct material able to withstand sufficient pressure.
- 3 Select clean copper pipes. Make sure that there is no dust or moisture inside the pipes. Blow the inside of the pipes with oxygen free nitrogen to remove any dust and foreign materials before connecting them.

#### NOTE

**A system with no moisture or oil contamination will give maximum performance and lifecycle compared to that of a poorly prepared system. Take particular care to ensure that all copper piping is clean and dry internally.**

#### DANGER

**The system design pressure is 4.15 MPa. The compression strength of the pipes must exceed 12.45 MPa (3 times the design pressure).**

#### CAUTION

**Cap the end of the pipe when pipe is to be inserted through a wall hole.**

**Do not put pipes on the ground directly without a cap or vinyl tape at the end of the pipe.**

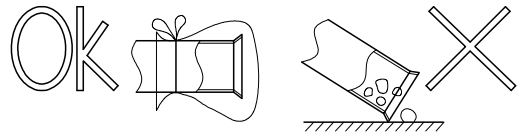

If piping installation is not completed until next day or over a longer period of time, braze off the ends of the piping and charge with oxygen free nitrogen through a Schrader valve type access fitting to prevent moisture and particle contamination.

Do not use insulation material that contains NH<sub>3</sub>, as it can damage copper pipe material and become a source of future leakage.

Completely insulate both refrigerant gas piping and liquid piping between the indoor unit and the outdoor unit.

If not insulated, in cooling mode and high ambient humidity conditions, dew will appear on the piping surface.

Refrigerant circuit and Water circuit must be performed and inspected by a licensed technician and must comply with all relevant European and national regulations.

### 8.2 REFRIGERANT PIPE CONNECTIONS

The DX-Interface unit is set up to be connected by Flare Nut (factory supplied). Perform the indicated pipe work by maintaining the dimensions indicated in the following tables.

#### ◆ Size of pipes

units: mm (inch)

Nominal Diameters	Outer diameters	Flare pipe dimensions A $\varnothing +0/-0.4$	Minimum thickness R410A	Flare nut dimensions B	Tightening Torque Nm
(1/4)	6.35	9.1	0.5	17	20
(3/8)	9.53	13.2	0.6	22	40

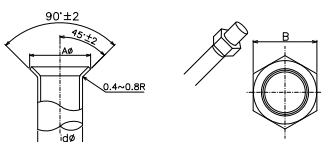

#### NOTE

**Flare nuts tightening torque**

**Always use two wrenches or fix spanners when tightening the flare nuts on the refrigerant pipes.**

**If any failure occurs during this process the result could be pipe damage or refrigerant leak.**

After connecting the refrigerant piping seal the open space between the knockout hole and refrigerant pipes by using insulation material as shown below:

A. Insulation.

B. Field-supplied refrigeration piping.

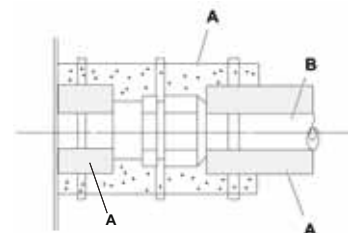

### 8.3 BRAZING WORK



#### CAUTION

*Use nitrogen gas for blowing during pipe brazing. If oxygen, acetylene or fluorocarbon gas is used, it will cause an explosion or poisonous gas.*

*A rust coating will appear inside of tubes if no nitrogen gas blowing is performed during brazing work. This film will be flecked off after operation and will circulate in the circuit, resulting in clogged expansion valves, etc, and the compressor will be affected.*

*Use a reducer valve when nitrogen gas blowing is performed during brazing. The gas pressure should be maintained within 0.03 to 0.05 Mpa. If excessively high pressure is applied to a pipe, it will cause an explosion.*

### 8.4 REFRIGERANT CHARGE



#### DANGER

*Do not charge OXYGEN, ACETYLENE, or other flammable and poisonous gases into the refrigerant circuit, as an explosion could occur. It is recommended that oxygen free nitrogen be charged for these types of test cycles when performing a leakage test or an airtight test. These types of gases are extremely dangerous.*

*Insulate the unions and flare-nuts at the piping connection part completely.*

*Insulate the liquid piping completely to avoid a decreased performance; if not, it will cause sweating on the surface of the pipe.*

*Charge refrigerant correctly. Overcharging or insufficient charging could cause a compressor failure.*

*Check for refrigerant leakage in detail. If a large refrigerant leakage occurred, it would cause difficulty with breathing or harmful gases would occur if a fire were in the room.*

*If the flare nut is tightened too hard, it may crack over time and cause refrigerant leakage.*



#### NOTE

*Please refer to Outdoor unit Installation Manual and Technical Catalogue for the calculating method of additional refrigerant charge according the piping length.*



## 9 ELECTRICAL WIRING

### 9.1 GENERAL CHECK

- 1 Ensure that the field-supplied electrical components (mains power switches, circuit breakers, wires, connectors and wire terminals) have been properly selected according to the electrical data indicated. Make sure that they comply with national and regional electrical codes.
- 2 Check to ensure that the power supply voltage is within +/-10% of the rated voltage.
- 3 Check to ensure that the power supply has an impedance low enough to guarantee that the starting voltage is at least 85% of the rated voltage.
- 4 Check to ensure that the ground wire is connected.
- 5 Connect a fuse of specified capacity.



**DANGER**  
Check to ensure that screws for terminal block are tightly fastened.



- CAUTION**
- Protect the wires, drain pipe and electrical parts from rats or other small animals. If not protected, rats may damage unprotected parts, and in the worst case scenario a fire could break out.
  - Wrap the accessory packing around the wires, and plug the wiring connection hole with the sealing material to protect the product from any condensed water and insects.

- **Tightly secure the wires with the cord clamp inside the indoor unit.**
- **Lead the wires through the knockout hole in the side cover when using conduit.**
- **Electrical wiring must comply with national and local codes.**
- **Check that the ground wire is securely connected.**



- DANGER**
- **Do not connect or adjust any wiring or connections unless the main power switch is OFF.**
  - **Check that the earth wire is securely connected, tagged and locked in accordance with national and local codes.**



**NOTE**  
Please refer to Outdoor and AHU (or equivalent indoor unit) installation manual.



**CAUTION**  
All the field wiring and electrical components must comply with local codes.

### 9.2 ELECTRICAL WIRING BETWEEN DX-INTERFACE AND INDOOR AND OUTDOOR UNIT

- Connect the electrical wires between the indoor unit and the outdoor unit, as shown in the next diagram.
- Follow the local codes and regulations when performing the electrical wiring.
- Use shielded wires for intermediate wiring to protect the units from noise obstacle at length of less than 300m and size in compliance with local codes.
- In the event that a conduit tube for field-wiring is not used, fix rubber bushes to the panel with adhesive.
- All the field wiring and equipment must comply with local and international codes.
- When a cable gland is not used, it must be sealed properly in order to ensure the correct control box sealing.



**CAUTION**  
Pay attention to the connection of the operating line. Incorrect connection may cause PCB failure.



**NOTE**  
Packing gland diameter specification: 6.0 mm (min) to 12.0 mm (max). If needed, install additional tube insulation or wind with insulation tape around the wire to make the wire thicker.

#### 9.2.1 Control box terminal board

##### ◆ DX-Interface EXV-(2.0-6.0)E

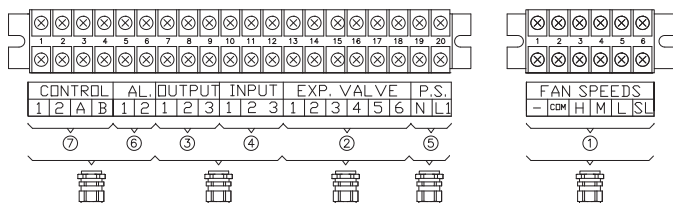

##### ◆ DX-Interface EXV-(8.0/10.0)E

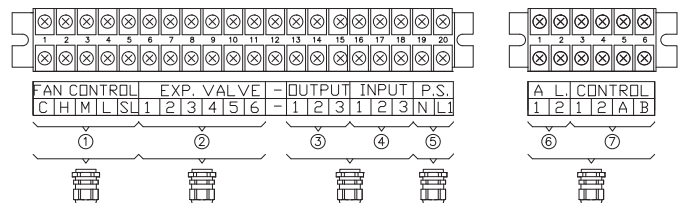

## 9.2.2 Expansion valve box terminal board

### ◆ DX-Interface EXV-(2.0-6.0)E / DX-Interface EXV-(8.0/10.0)E

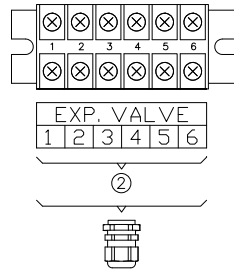

## 9.2.3 Terminal board connection and remarks

Item	Description	Wire Specification (EN60335-1)
1	<b>Fan Control (Optional: Fan speeds control by Hitachi Remote controller) <sup>(1)</sup></b> <ul style="list-style-type: none"> <li>C-Common; H-High; M-Medium; L-Low; SL-Slow.</li> <li>EXV-(2.0-6.0)E: 230V output signal. Maximum current allowed: 2,5A</li> <li>EXV-(8.0/10.0)E: Free contact. Maximum current allowed: 15A.</li> <li>See "Fan tap setting" chapter 9.2.4 for fan tap setting.</li> </ul>	EXV-(2.0-6.0)E: 5x 0,75 mm <sup>2</sup> EXV-(8.0/10.0)E: 5x 3,5 mm <sup>2</sup>
2	<b>Expansion Valve connection (Necessary).</b> <ul style="list-style-type: none"> <li>Link to expansion valve assy. Number links from 1 to 6 must match in e-box terminal board and expansion valve terminal board.</li> </ul>	6 x 0.5 mm <sup>2</sup>
3	<b>Output Signals (Optional)</b> <ul style="list-style-type: none"> <li>Different output signals useful to embed the kit into a system.</li> <li>Refer to Hitachi indoor unit Service Manual for further information about output signals setting and specifications.</li> </ul>	3 x 0.5 mm <sup>2</sup>
4	<b>Input Signals (Optional)</b> <ul style="list-style-type: none"> <li>Different input signals useful to embed the kit into a system.</li> <li>Refer to Hitachi indoor unit Service Manual for further information about input signals setting and specifications.</li> </ul>	3 x 0.5 mm <sup>2</sup>
5	<b>Power supply (Necessary)</b> <ul style="list-style-type: none"> <li>Single phase supplying. Refer to Hitachi indoor units technical catalogue for further information about the connection modes allowed.</li> </ul>	1~ 230V 50Hz Power supply cable section: 3 x 0.75 mm <sup>2</sup>
6	<b>Alarm signal (Optional)</b> <ul style="list-style-type: none"> <li>Input signal used for alarm link between the DX-Interface and the unit connected. If the jumper is open between pins 1 and 2 in AL. terminal, the DX-Interface board detects it as an abnormality and stops the system. Alarm code 01 is showed on the remote controller. Connect again pins 1 and 2 to restart the system.</li> </ul>	2 x 0.5 mm <sup>2</sup>
7	<b>Control Signal (Necessary)</b> <ul style="list-style-type: none"> <li>Remote controller must be connected between pins A and B (without polarity).</li> <li>Communication link with the outdoor unit is done via pins 1 and 2. Refer to Hitachi indoor units Technical Catalogue or Outdoor unit Service Manual for further information about the configurations allowed.</li> </ul>	Twisted-pair shielded cable 2 x 0.75 mm <sup>2</sup>

## 9.2.4 Fan tap setting

### ◆ DX-Interface EXV-(2.0-6.0)E

RC setting	C5-00 (Factory setting)	C5-01	C5-02
High	M	H	L
Medium	L	M	L
Low	SL	L	SL

### ◆ DX-Interface EXV-(8.0/10.0)E

RC setting	C5-00 (Factory setting)	C5-01	C5-02
High	M	H	L
Medium	L	M	L
Low	SL	L	SL

<sup>(1)</sup> If the fan motor is drove by the fan control connection port (item 1),it is necessary to connect always SL fan tap. This speed is used in some special working modes as could be during defrosting time. If it is not connected the indoor unit fan motor could be stopped whatever the fan configuration was.

Please refer to HITACHI Indoor and Controllers Technical Catalogue and Service Manual for fan tap setting through the remote control.

### 9.3 DIP SWITCH SETTINGS

#### 9.3.1 Quantity and location of Dip Switches

Dips switches location is the following:

##### ◆ DX-Interface EXV-(2.0-6.0)E

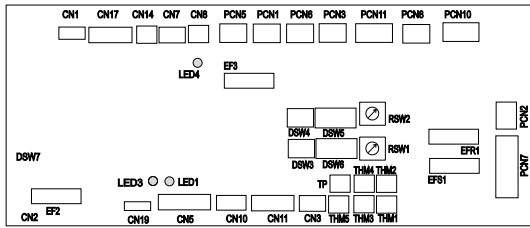

##### ◆ DX-Interface EXV-(8.0/10.0)E

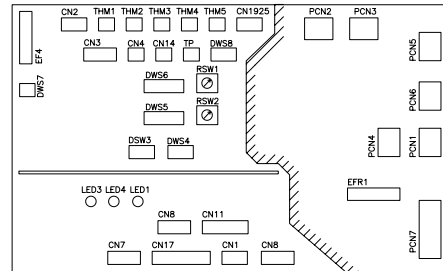

### CAUTION

Before setting DIP switches, firstly turn off power source and set the position of the dips switches. If the switches are set without turning off the power source, the contents of the setting are invalid.

#### 9.3.2 Settings

##### ◆ DSW3: capacity code setting

No setting is required. This DIP switch is used to set the capacity code corresponding to the DX-Interface power (HP). Settings position before shipment is:

HP	2.0	2.5	3.0	4.0
Setting position				
HP	5.0	6.0	8.0	10.0
Setting position				

##### ◆ DSW4: Unit Model Code Setting

No setting is required. Settings position before shipment is:

EVX-(2.0-6.0)E	
EVX-(8.0-10.0)E	

##### ◆ DSW5 and RSW2: Refrigerant Cycle No. Setting

Setting is required. This switch is used to set the refrigerant cycle number.

	Setting position (DSW5)		Setting position (RSW2)
Tens setting (second digit)		Unit setting (first digit)	
Example for number 5		+	

##### ◆ DSW6 and RSW1: Unit no. setting

Set DSW6 and RSW1 to modify the indoor unit address. The setting must be made so that it does not overlap the setting of other indoor units in the same refrigerant cycle. If the setting is not made manually, the automatic address function will be enable.

Factory-set to a value of up to 63.

DSW6	RSW1

##### Example of setting for unit no. 16

DSW6	RSW1

##### ◆ DSW7 switch: Fuse recovery and remote control selection

No settings are required. All switches are factory-set to OFF. PC-ART remote control selection.



If high voltage is applied to P.S. terminal L1 and N, the fuse on PCB1 (M) is deactivated. Should this occur, correct the TB1 wiring and active contact 1

##### ◆ DSW8: (Not used)

No setting is required, due to setting before shipment. Setting position before shipment is all OFF.

### NOTE

The mark ■ indicates position of dips switches. Figures show setting before shipment or after selection.